

Jomar[®] VALVE

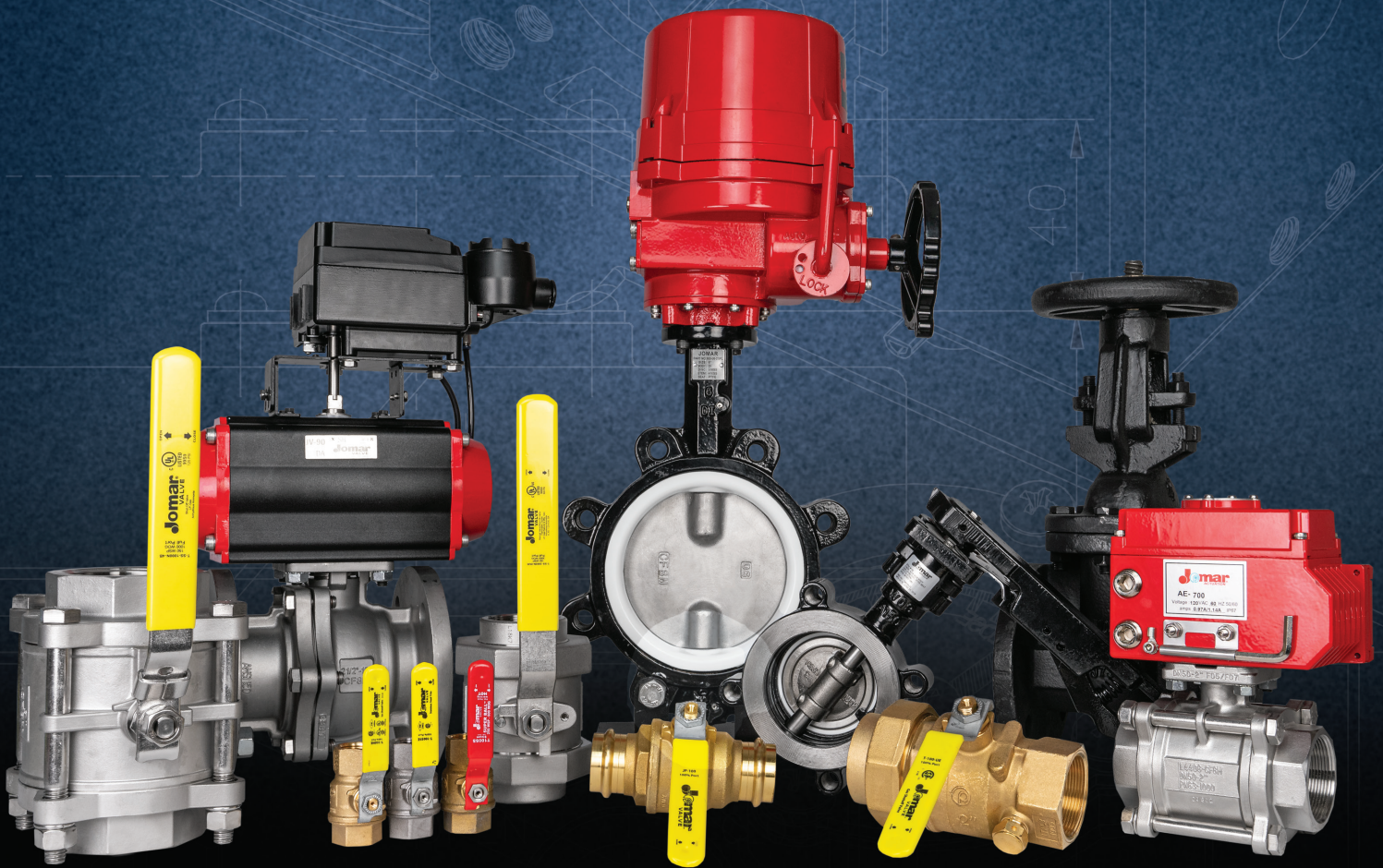

INDUSTRIAL & ACTUATION CATALOG

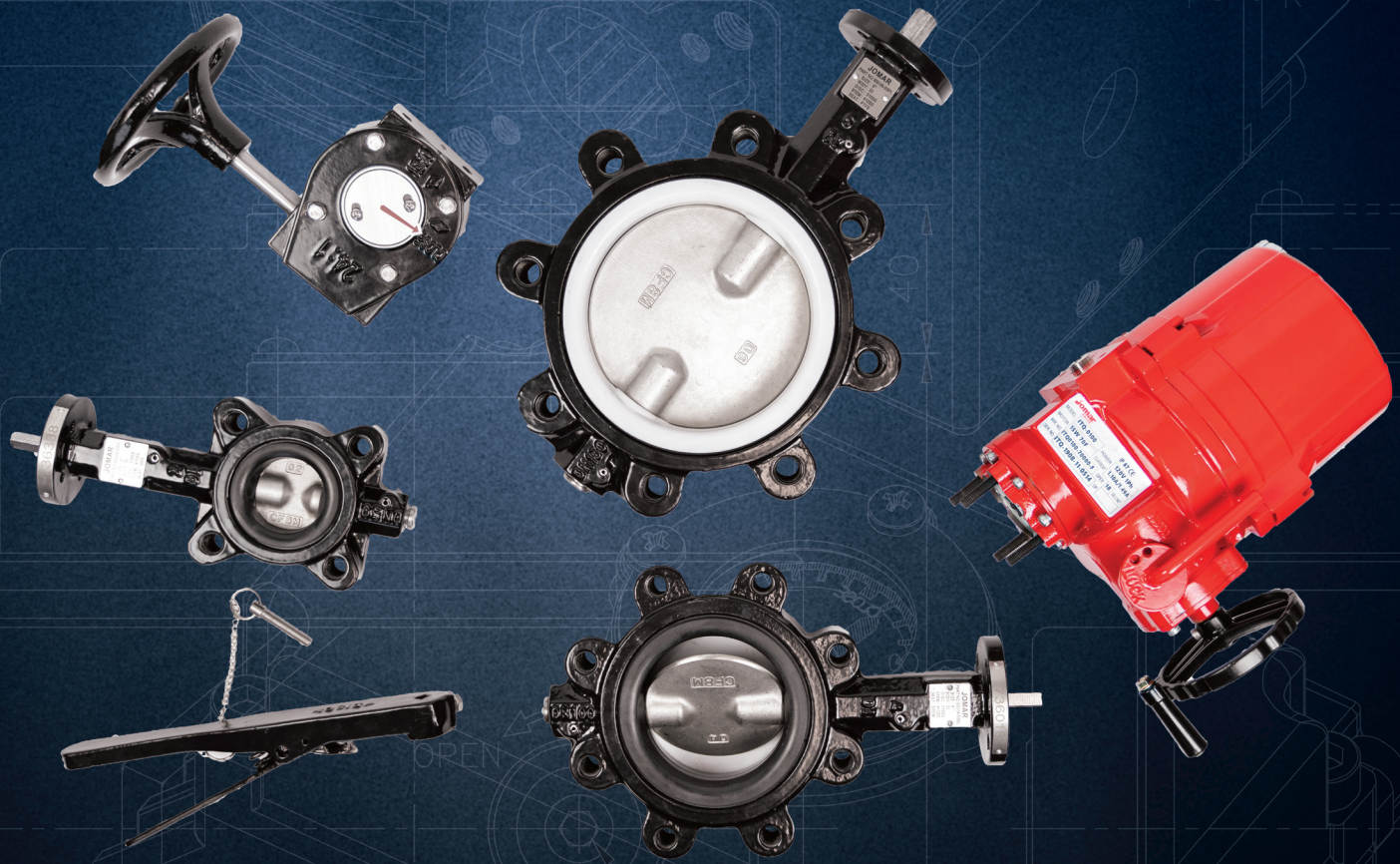

BRASS BALL VALVES

T-100CG	3
S-100CG	3
T-100SSS	4
T-100STN	4
T-100NE	5
T-100SSE	5
T-100FMN	6
T-100UE	6
T-100FBG	7
JP-100	7
JP-100 XLC	8
T-84-M	8
T-82-M	9
T-83C	9
JF-100T	10
JF-100S	10
JF-100TFM	11

HIGH PERFORMANCE BUTTERFLY VALVES

SERIES 600 - LUG TYPE	12-13
-----------------------	-------

BUTTERFLY VALVES

SERIES 600 - LUG	14
SERIES 900 - WAFER	15

BUTTERFLY HANDLES

LEVER HANDLE	16
GEAR OPERATOR	16

HIGH PERFORMANCE BUTTERFLY HANDLES

LEVER HANDLE	17
LEVER HANDLE - SS	17

ADD-A-VALVE

AAV	18
-----	----

GATE VALVES

F-351	19
F-361	19
T-301	20
S-301	20

STRAINERS & CHECK VALVES

F-651	21
F-571	21
F-591	22
T-501	22
T-511	23
T-550	23
T-521G	24
S-521G	24

STAINLESS STEEL BALL VALVES

T-SS-1001N	25
T-SS-2000N	25
T-SS-2000N-MF	26
T-SS-1050N-3L	26
T-SS-900N	27
T-SS-2000N-DH	28
A101-DH	29
T-SS-1000	29
T-SS-1000N-4B	30
S-SS-1000N-4B	30
T-SS-2001N-4B	31
S-SS-2001N-4B	31
T-SS-2002N-DUE	32
S-SS-2002N-DUE	32

CARBON STEEL BALL VALVES

T-CS-1001N-SS	33
T-CS-2000N-SS	33
T-CS-1000N-SS-4B	34
S-CS-1000N-SS-4B	34
T-CS-2002N-SS-DUE	35
S-CS-2002N-SS-DUE	35
T-CS-2001N-SS-4B	36
S-CS-2001N-SS-4B	36
T-CS-4000	37

THREAD SEALANT

COMPARISON CHART	38
------------------	----

FLANGED BALL VALVES

FL-SS-100-150	39
FL-SS-100-300	39
FL-CS-100-150	40
FL-CS-100-300	40

ACTUATORS

ELECTRICAL	41-42
PNEUMATIC	43

ACTUATION ACCESSORIES

AEP-100	44
ASM-200	44
APP-200	44
ASV-120	44

CPVC/PVC VALVES

T/S-703	45
T-701	46
S-701	46

DIELECTRIC UNIONS

LEAD FREE BRASS FIP X FIP	47
GALVANIZED FIP X FIP	47
BLACK IRON FIP X FIP	48

DIRECT MOUNT VALVES

A-101	49
T-100 DIRECT MOUNT	49
A1000	50
A1001	50
A751T/L	51
A766T/L	51
A850T/L	52
A2020D	52

TOPWORKS

2001N-4B	53
2002N-DUE	53
1000N-4B	55
FL-CS/SS-150	56
FL-CS/SS-300	56
1001N	57
2000N	57

ACTUATION RESOURCES

TECHNICAL TABLES	58-60
ISO MOUNT PATTERNS	61
QUESTIONNAIRE	63

T-100CG



2 PIECE • FULL PORT • THREADED CONNECTION • 600 WOG

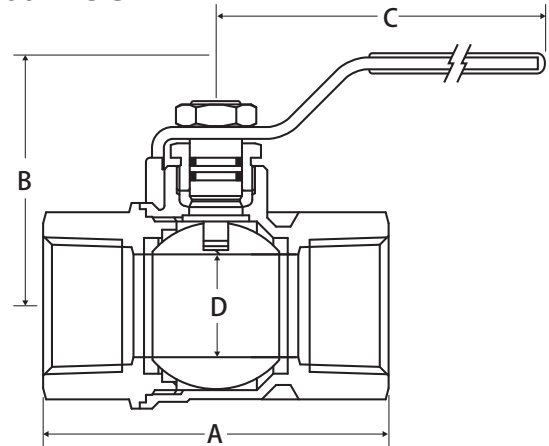

- Dezincification resistant brass alloy 1/2"-4" valves
- Blow-out proof stem
- Triple sealing stem with 2 FKM o-rings and 2nd Generation PTFE seal
- 100% leak tested
- Made in Italy
- Leakproof stem - Lifetime Warranty
- 29 in-Hg vacuum rating

SEE P. 37 FOR PREFABRICATED ISO-5211 MOUNTED BRACKET (T-100DM)

PART NUMBER	SIZE	A	B	C	D	Cv
100-403G	1/2"	2.00	1.53	2.95	0.59	16.82
100-404G	3/4"	2.34	1.95	3.74	0.79	34.80
100-405G	1"	2.67	2.40	4.75	0.97	52.20
100-406G	1-1/4"	3.22	2.59	4.75	1.23	112.52
100-407G	1-1/2"	3.68	3.22	6.00	1.49	174.00
100-408G	2"	4.29	3.40	6.00	1.99	255.20
100-409G	2-1/2"	6.06	4.60	8.00	2.46	350.32
100-410G	3"	7.08	4.90	8.00	2.99	563.76
100-411G	4"	8.57	5.90	9.88	4.00	879.28

VALVE SEAT RATINGS

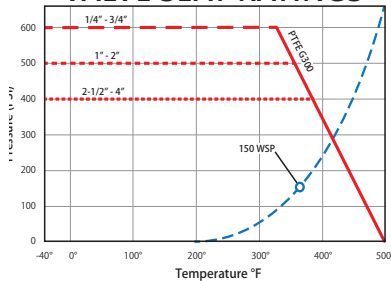

S-100CG



2 PIECE • FULL PORT • SOLDER CONNECTION • 600 WOG

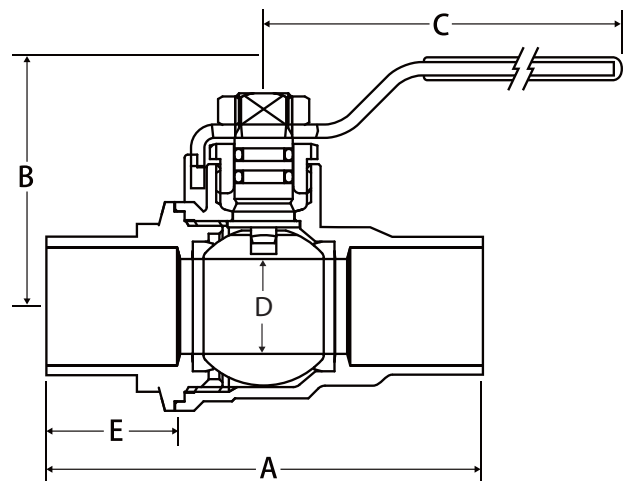

- Dezincification resistant brass alloy 1/2"-4" valves
- Triple sealing stem with 2 FKM o-rings and 2nd Generation PTFE seal
- Blow-out proof stem
- 100% leak tested
- 100% Made in Italy
- Leakproof stem - Lifetime Warranty
- 29 in-Hg vacuum rating

PART NUMBER	SIZE	A	B	C	D	E	Cv
100-413G	1/2"	2.48	1.56	2.95	0.59	0.51	16.82
100-414G	3/4"	3.26	2.05	3.74	0.79	0.76	34.80
100-415G	1"	3.94	2.55	4.75	0.97	0.92	52.20
100-416G	1-1/4"	4.50	2.66	4.75	1.23	0.98	112.52
100-417G	1-1/2"	5.07	3.31	6.00	1.49	1.10	174.00
100-418G	2"	6.22	3.60	6.00	1.99	1.34	255.20
100-419G	2-1/2"	7.28	4.74	8.00	2.46	1.45	350.32
100-420G	3"	8.48	5.05	8.00	2.99	1.63	563.76
100-421G	4"	10.08	5.90	9.84	4.00	2.20	879.28

VALVE SEAT RATINGS

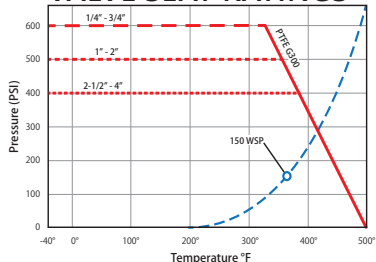

BRASS BALL VALVES



T-100SSS



2 PIECE • FULL PORT • THREADED CONNECTION • 600 WOG • STEAM TRIM



- Blow-out proof stem
- Triple sealing stem with FKM o-rings and graphite seal
- 250 WSP rating
- Patent pending design
- 100% leak tested
- 100% Made in Italy
- Special high temperature resistant handle
- Leakproof stem - Lifetime Warranty
- 29 in-Hg vacuum rating
- Accessories available

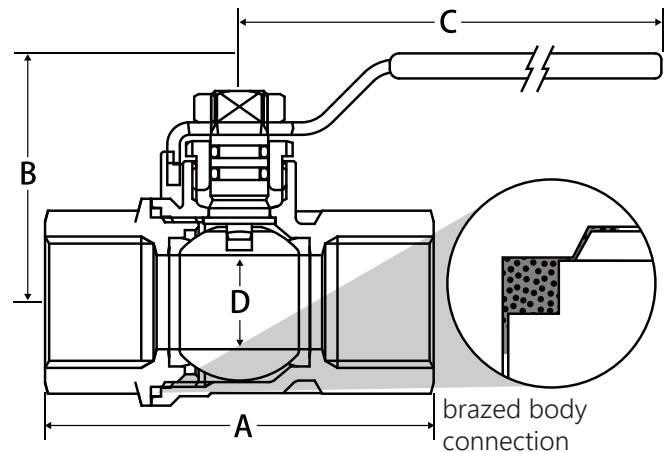

VALVE SEAT RATINGS

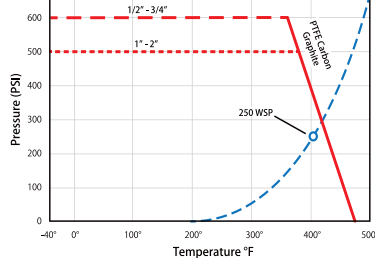

PART NUMBER	SIZE	A	B	C	D	Cv
100-533	1/2"	2.45	1.53	2.95	0.59	16.82
100-534	3/4"	2.71	1.95	3.74	0.79	34.80
100-535	1"	3.30	2.40	4.75	0.97	52.20
100-536	1-1/4"	3.80	2.59	4.75	1.23	112.52
100-537	1-1/2"	4.16	3.22	6.00	1.49	174.00
100-538	2"	5.00	3.40	6.00	1.99	255.20

T-100STN



2 PIECE • FULL PORT • THREADED CONNECTION • 600 WOG • SIDE TAP



- Triple sealing stem with 2 FKM o-rings and 2nd Generation PTFE seal
- Blow-out proof stem
- 100% leak tested
- 100% Made in Italy
- 3/8" - 1/2" have 1/8" FIP side tap
- 3/4" - 2" have 1/4" FIP side tap
- Leakproof stem - Lifetime Warranty
- 29 in-Hg vacuum rating
- Accessories available

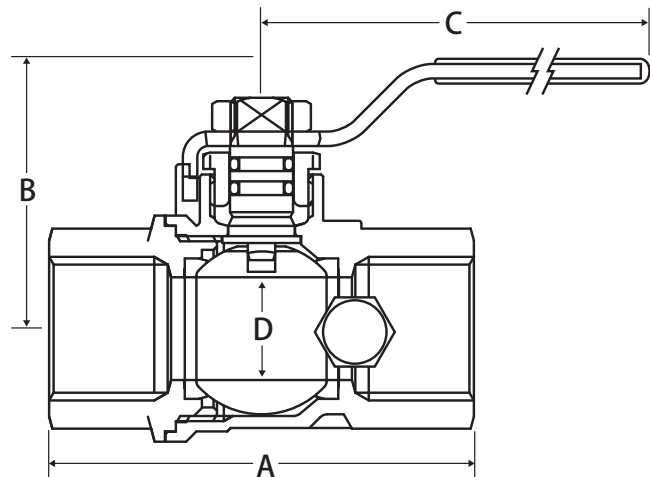

VALVE SEAT RATINGS

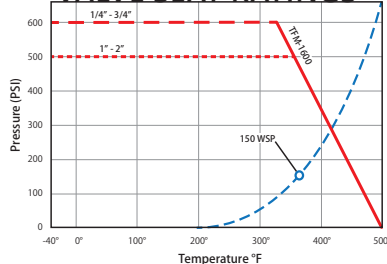

PART NUMBER	SIZE	A	B	C	D	Cv
170-102	3/8"	2.02	1.41	2.95	0.39	7.77
170-103	1/2"	2.48	1.53	2.95	0.59	16.82
170-104	3/4"	2.76	1.95	3.74	0.79	34.80
170-105	1"	2.81	2.40	4.75	0.97	52.20
170-106	1-1/4"	4.03	2.59	4.75	1.23	112.52
170-107	1-1/2"	4.72	3.22	6.00	1.49	174.00
170-108	2"	5.23	3.40	6.00	1.99	255.20

T-100NE

2 PIECE • FULL PORT • THREADED CONNECTION • 600 WOG



- Blow-out proof stem
- Triple sealing stem with 2 FKM o-rings and 2nd Generation PTFE seal
- 100% leak tested
- 100% Made in Italy
- Leakproof stem - Lifetime Warranty
- 29 in-Hg vacuum rating
- ACCESSORIES AVAILABLE

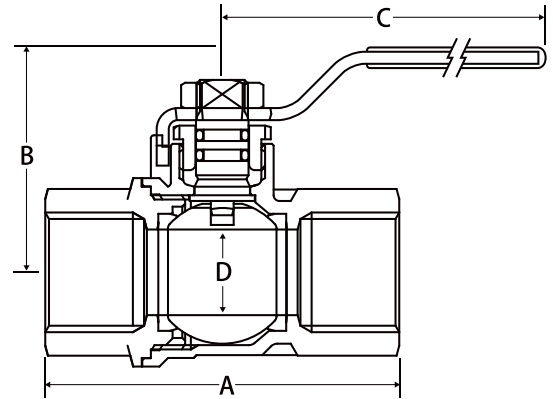
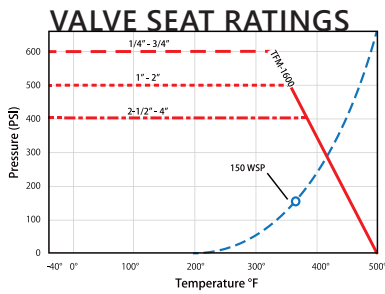

SEE P. 37 FOR PREFABRICATED ISO-5211 MOUNTED BRACKET (T-100DM)

PART NUMBER	SIZE	A	B	C	D	Cv
100-701	1/4"	1.86	1.41	2.95	0.39	7.66
100-702	3/8"	1.86	1.41	2.95	0.39	7.77
100-703	1/2"	2.45	1.53	2.95	0.59	16.82
100-704	3/4"	2.71	1.95	3.74	0.79	34.80
100-705	1"	3.30	2.40	4.75	0.97	52.20
100-706	1-1/4"	3.80	2.59	4.75	1.23	112.52
100-707	1-1/2"	4.16	3.22	6.00	1.49	174.00
100-708	2"	5.00	3.40	6.00	1.99	255.20
100-709	2-1/2"	6.06	4.60	8.00	2.46	350.32
100-710	3"	7.08	4.90	8.00	2.99	563.76
100-711	4"	8.57	5.90	9.88	4.00	879.28

T-100SSE

2 PIECE • FULL PORT • THREADED CONNECTION • 600 WOG

STAINLESS STEEL BALL AND STEM



- T.E.A. Ternary Eco Alloy® coated body to prevent dezincification and galvanic corrosion
- Triple sealing stem with 2 FKM o-rings and 2nd Generation PTFE seal
- Blow-out proof stem
- 100% leak tested
- 100% Made in Italy
- Leakproof stem - Lifetime Warranty
- 29 in-Hg vacuum rating
- Accessories available

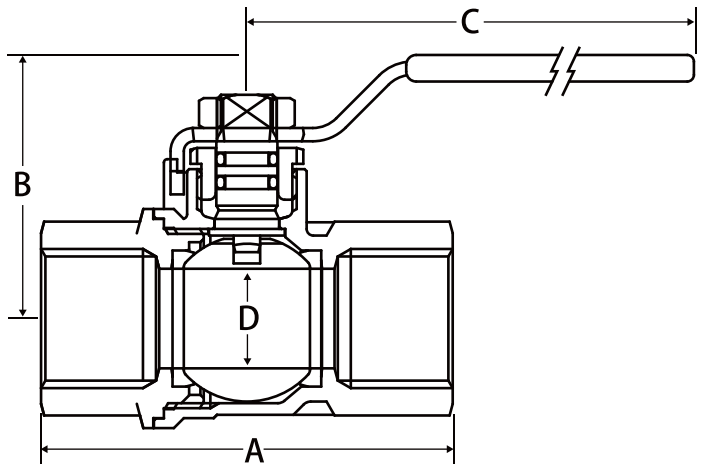
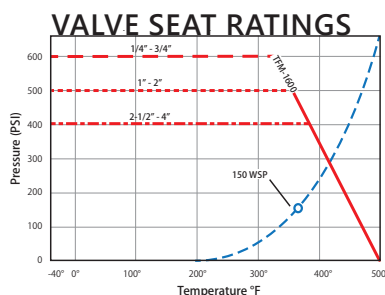

PART NUMBER	SIZE	A	B	C	D	Cv
100-501	1/4"	1.86	1.41	2.95	0.39	7.66
100-502	3/8"	1.86	1.41	2.95	0.39	7.77
100-503	1/2"	2.45	1.53	2.95	0.59	16.82
100-504	3/4"	2.71	1.95	3.74	0.79	34.80
100-505	1"	3.30	2.40	4.75	0.97	52.20
100-506	1-1/4"	3.80	2.59	4.75	1.23	112.52
100-507	1-1/2"	4.16	3.22	6.00	1.49	174.00
100-508	2"	5.00	3.40	6.00	1.99	255.20
100-509	2-1/2"	6.06	4.60	8.00	2.46	350.32
100-510	3"	7.08	4.90	8.00	2.99	563.76

BRASS BALL VALVES



T-100FMN

2 PIECE • FULL PORT • MALE X FEMALE THREADED CONNECTION • 600 WOG

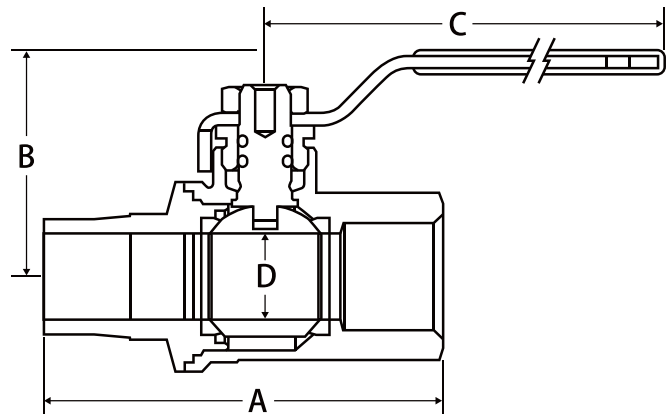

- Blow-out proof stem
- Triple sealing stem with 2 FKM o-rings and 2nd Generation PTFE seal
- 100% leak tested
- 100% Made in Italy
- Leakproof stem - Lifetime Warranty
- 29 in-Hg vacuum rating
- Accessories available

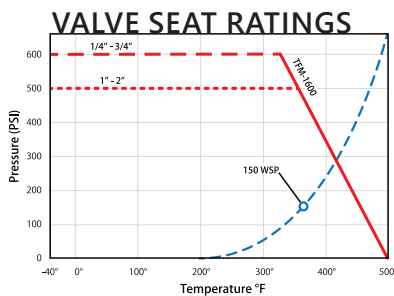

PART NUMBER	SIZE	A	B	C	D	Cv
100-601	1/4"	2.29	1.41	2.95	0.39	7.66
100-602	3/8"	2.26	1.41	2.95	0.39	7.77
100-603	1/2"	2.75	1.53	2.95	0.59	16.82
100-604	3/4"	3.10	1.95	3.74	0.79	34.80
100-605	1"	3.68	2.40	4.75	0.97	52.20

T-100UE

2 PIECE • FULL PORT • SINGLE UNION END • THREADED CONNECTION • 600 WOG • SIDE TAP

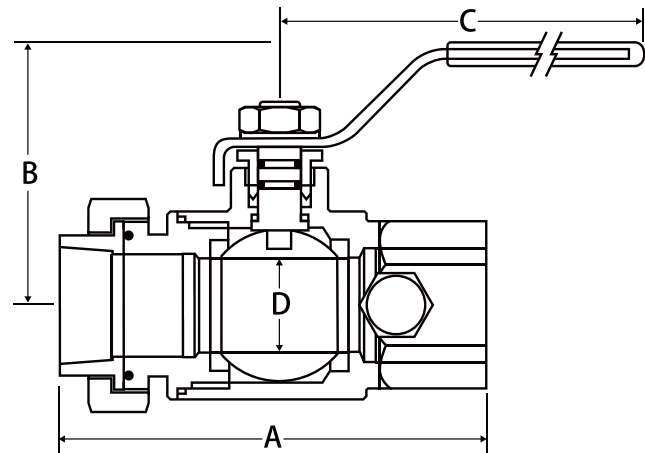

- Triple sealing stem with 2 FKM o-rings and 2nd Generation PTFE seal
- Blow-out proof stem
- 100% leak tested
- 100% Made in Italy
- FIP x union FIP
- 3/8" - 1/2" have 1/8" FIP side tap
- 3/4" - 2" have 1/4" FIP side tap
- Leakproof stem - Lifetime Warranty
- 29 in-Hg vacuum rating
- Accessories available

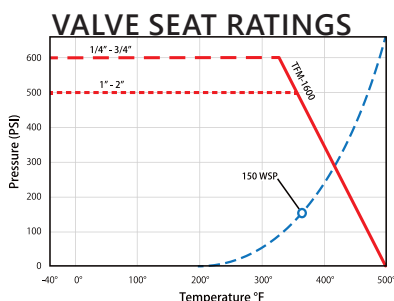

PART NUMBER	SIZE	A	B	C	D	Cv
160-102	3/8"	2.93	1.41	2.95	0.39	7.77
160-103	1/2"	3.17	1.53	2.95	0.59	16.82
160-104	3/4"	3.52	1.88	3.74	0.79	34.80
160-105	1"	4.19	2.36	4.75	0.97	52.20
160-106	1-1/4"	5.01	2.59	4.75	1.23	112.52
160-107	1-1/2"	5.57	3.22	6.00	1.49	174.00
160-108	2"	6.31	3.50	6.00	1.99	255.20

T-100FBG

FULL PORT • THREADED CONNECTION • 400 WOG • INTEGRATED STRAINER



- Blow-out proof stem
- Corrosion resistant brass
- 100% leak tested
- 100% Made in Italy
- Reversible handle
- Leakproof stem - Lifetime Warranty
- Accessories available
- Triple sealing stem with 2 FKM o-rings and Teflon® seal
- Shipped standard with 304 SS 20 mesh screen
- Available mesh screens: 40, 60, 80, 100

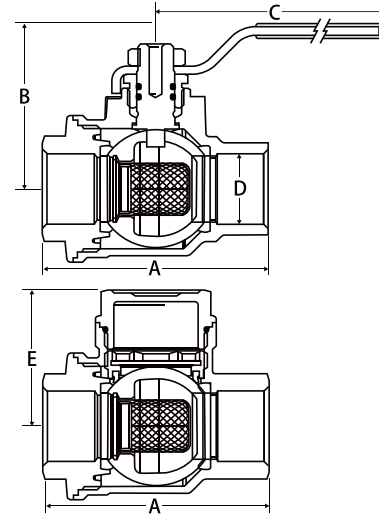

VALVE SEAT RATINGS

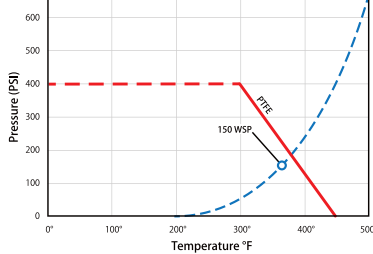

PART NUMBER	SIZE	A	B	C	D	E	Cv
100-833G	1/2"	2.73	2.20	3.74	0.69	1.47	8.09
100-834G	3/4"	3.03	2.40	4.72	0.89	1.73	8.67
100-835G	1"	3.74	2.60	4.72	1.12	2.01	16.76
100-836G	1-1/4"	4.73	3.23	5.91	1.40	2.36	23.12
100-837G	1-1/2"	5.00	3.50	5.91	1.77	2.91	42.77
100-838G	2"	6.06	3.56	5.91	1.77	3.01	42.77

JP-100

2 PIECE • FULL PORT • PRESS CONNECTION • 250 WOG



- Blow-out proof stem
- Triple sealing stem with 2 FKM o-rings and 2nd Generation PTFE seal
- Corrosion resistant brass
- 100% leak tested
- 100% Made in Italy
- Leakproof stem - Lifetime Warranty
- Accessories available

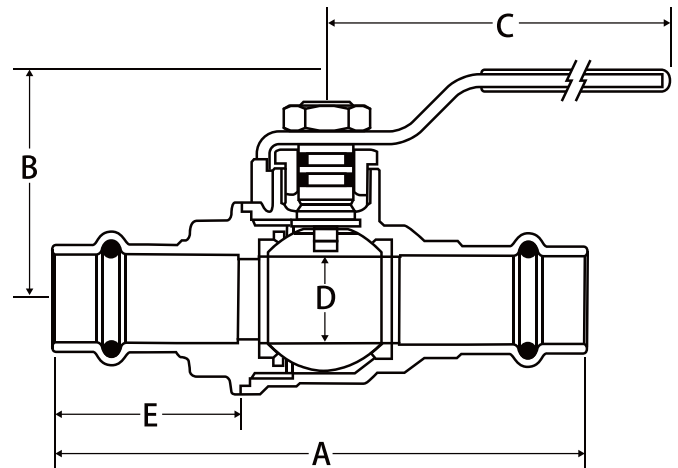

PART NUMBER	SIZE	A	B	C	D	E	Cv
100-203	1/2"	3.54	1.53	2.95	0.59	1.24	16.82
100-204	3/4"	3.84	1.95	3.74	0.79	1.28	34.80
100-205	1"	4.31	2.40	4.75	0.97	1.38	52.20
100-206	1-1/4"	4.80	2.59	4.75	1.23	1.30	112.52
100-207	1-1/2"	5.61	3.22	6.00	1.49	1.50	174.00
100-208	2"	7.16	3.40	6.00	1.99	2.01	255.20

BRASS BALL VALVES



JP-100XLC



2 PIECE • FULL PORT • PRESS XLC CONNECTION • 200 WOG



- Blow-out proof stem
- Triple sealing stem with 2 FKM o-rings and 2nd Generation PTFE seal
- Corrosion resistant brass
- 100% leak tested
- 100% Made in Italy
- Leakproof stem - Lifetime Warranty
- Accessories available

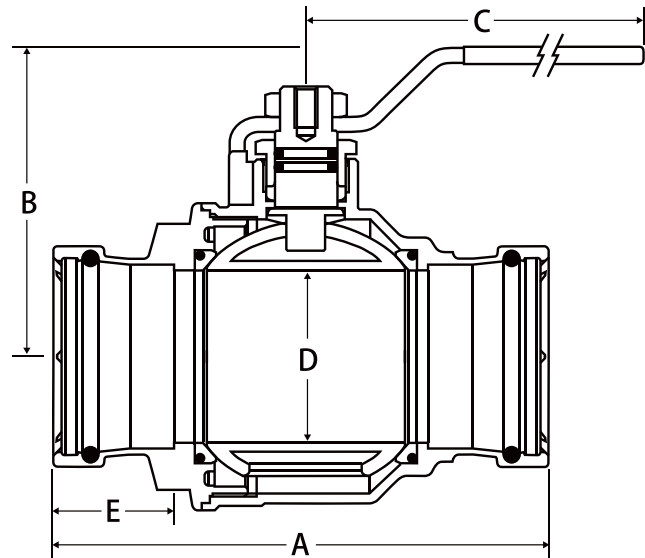

PART NUMBER	SIZE	A	B	C	D	E	Cv
100-209XLC	2-1/2"	7.13	4.72	8.00	2.46	1.75	350.32
100-210XLC	3"	8.49	5.31	8.00	2.99	1.92	563.76
100-211XLC	4"	10.79	5.90	9.88	4.00	2.22	879.28

T-84-M



1 PIECE • STANDARD PORT • MINI VALVES • THREADED CONNECTION • 450 WOG



- Blow-out proof stem
- Single O-ring stem design
- Chrome plated brass
- 100% leak tested
- 100% Made in Italy

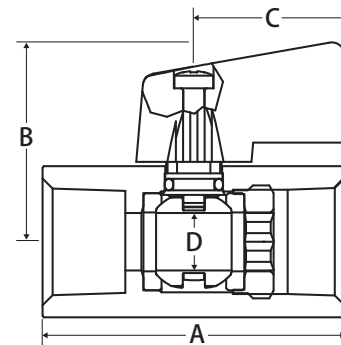

PART NUMBER	SIZE	A	B	C	D
FIP X FIP					
100-430	1/8"	1.54	1.05	0.86	0.31
100-431	1/4"	1.70	1.05	0.86	0.31
100-432	3/8"	1.70	1.07	0.86	0.31
100-433	1/2"	2.09	1.16	0.86	0.39
MIP X FIP					
100-440	1/8"	1.54	1.05	0.86	0.31
100-441	1/4"	1.70	1.05	0.86	0.31
100-442	3/8"	1.70	1.07	0.86	0.31
100-443	1/2"	2.09	1.16	0.86	0.39
EXTENDED HANDLE					
100-460	1/8"	1.54	1.05	2.28	0.31
100-461	1/4"	1.70	1.05	2.28	0.31
100-462	3/8"	1.70	1.07	2.28	0.31
100-463	1/2"	2.09	1.16	2.28	0.39

VALVE SEAT RATINGS

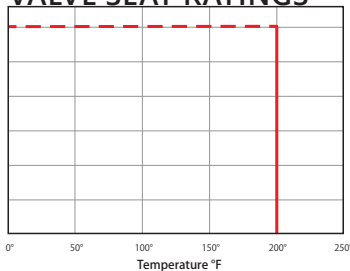

T-82-M



2 PIECE • FULL PORT • MINI VALVES • THREADED CONNECTION • 600 WOG

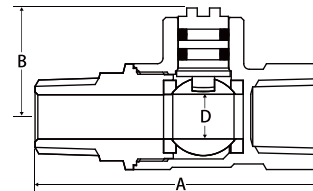
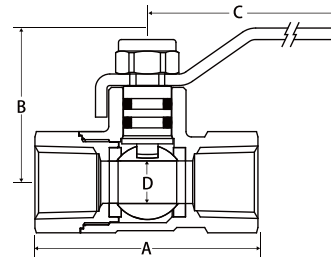
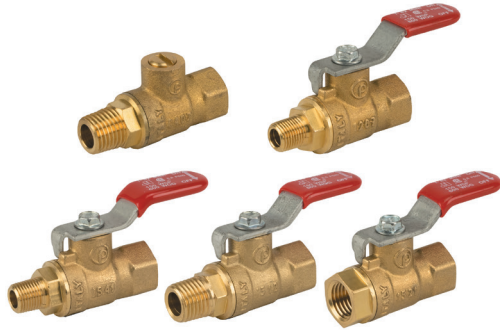

- Greater flow rate
- Blow-out proof stem
- 2 FKM o-rings
- Large raised wrench flats
- 100% leak tested
- Made in Italy
- Leakproof stem - Lifetime Warranty

VALVE SEAT RATINGS

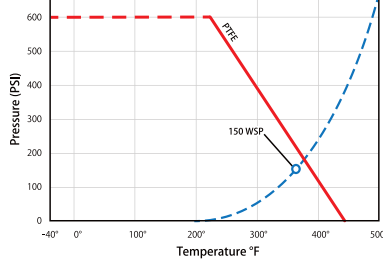

PART NUMBER	SIZE	A	B	C	D
MINI SCREWDRIVER SLOT HANDLE					
100-295	1/4" FIP x 1/4" MIP	2.01	0.77	-	0.31
LEVER HANDLE					
100-297	1/8" FIP x 1/8" MIP	1.96	1.14	1.69	0.31
100-298	1/4" FIP x 1/8" MIP	1.96	1.14	1.69	0.31
100-299	1/4" FIP x 1/4" MIP	2.01	1.14	1.69	0.31
100-300	1/4" FIP x 1/4" FIP	1.65	1.14	1.69	0.31

T-83C



FULL PORT • THREADED CONNECTION • 400 WOG • INTEGRATED STRAINER

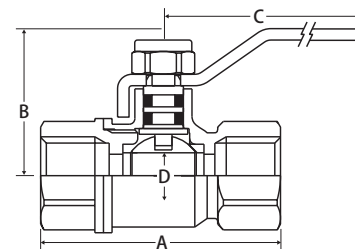
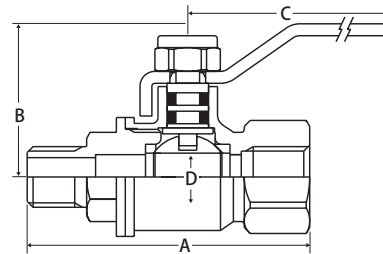
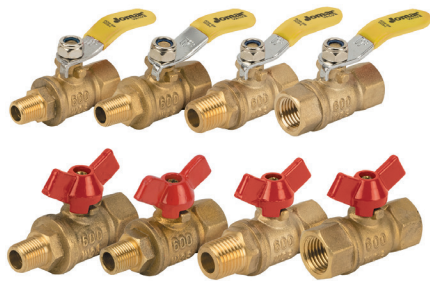

- Large raised wrench flats
- 2 Buna-N o-rings
- 100% leak tested

VALVE SEAT RATINGS

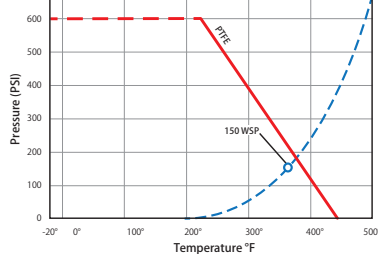

PART NUMBER	SIZE	A	B	C	D
LEVER HANDLE					
100-397	1/8" FIP X 1/8" MIP	1.90	1.07	1.77	0.28
100-398	1/4" FIP X 1/8" MIP	1.93	1.07	1.77	0.28
100-399	1/4" FIP X 1/4" MIP	2.01	1.07	1.77	0.28
100-400	1/4" FIP X 1/4" FIP	1.65	1.07	1.77	0.28
T-HANDLE					
100-397TH	1/8" FIP X 1/8" MIP	1.90	1.10	1.33	0.28
100-398TH	1/4" FIP X 1/8" MIP	1.93	1.10	1.33	0.28
100-399TH	1/4" FIP X 1/4" MIP	2.01	1.10	1.33	0.28
100-400TH	1/4" FIP X 1/4" FIP	1.65	1.10	1.33	0.28

BRASS BALL VALVES



JF-100T



2 PIECE • FULL PORT • THREADED CONNECTION • 600 WOG

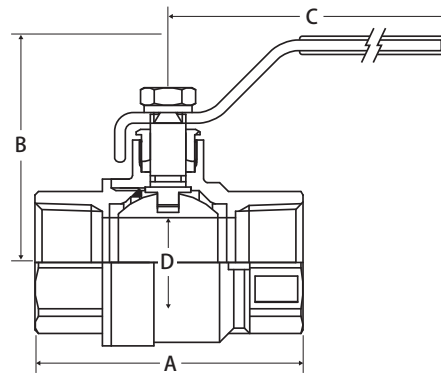

- Gland follower and single o-ring stem design
- Blow-out proof stem
- 100% leak tested

VALVE SEAT RATINGS

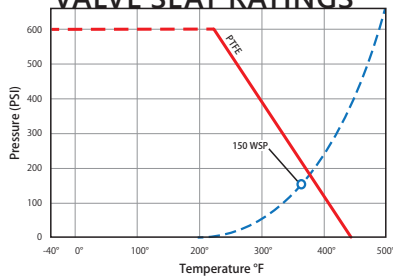

PART NUMBER	SIZE	A	B	C	D	Cv
100-101	1/4"	1.73	1.69	3.35	0.39	7.7
100-102	3/8"	1.73	1.69	3.35	0.39	7.8
100-103	1/2"	2.28	1.81	3.35	0.59	16.8
100-104	3/4"	2.52	2.36	4.29	0.75	34.8
100-105	1"	2.97	2.52	4.29	0.98	52.2
100-106	1-1/4"	3.44	2.52	5.63	1.26	112.5
100-107	1-1/2"	3.88	2.72	5.63	1.57	174.0
100-108	2"	4.29	3.03	5.63	1.97	255.2
100-109	2-1/2"	5.59	4.25	7.76	2.52	350.3
100-110	3"	6.34	4.92	8.37	2.95	563.7
100-111	4"	7.83	5.85	9.25	3.90	879.3

JF-100S

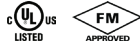

2 PIECE • FULL PORT • SOLDER CONNECTION • 600 WOG

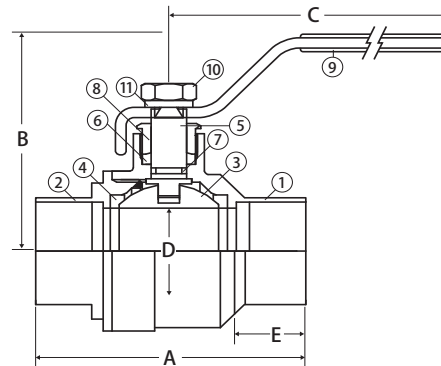

- Gland follower and single o-ring stem design
- Blow-out proof stem
- 100% leak tested

VALVE SEAT RATINGS

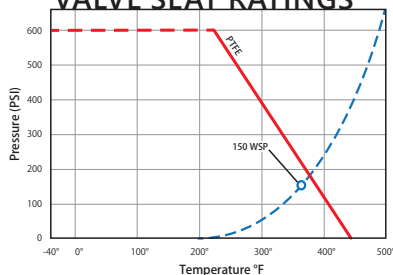

PART NUMBER	SIZE	A	B	C	D	E
100-113	1/2"	2.17	1.81	3.35	0.59	0.50
100-114	3/4"	2.80	2.36	4.29	0.75	0.75
100-115	1"	3.27	2.52	4.29	0.98	0.86
100-116	1-1/4"	4.10	2.52	5.63	1.26	1.08
100-117	1-1/2"	4.33	2.72	5.63	1.57	0.98
100-118	2"	5.34	3.03	5.63	1.97	1.21
100-119	2-1/2"	6.39	4.25	7.76	2.52	1.48
100-120	3"	7.10	4.92	8.37	2.95	1.66
100-121	4"	9.56	5.85	9.25	3.90	2.22
100-110	3"	6.34	4.92	8.37	2.95	563.7
100-111	4"	7.83	5.85	9.25	3.90	879.3

JF-100TFM

2 PIECE • FULL PORT • MALE X FEMALE CONNECTION • 600 WOG

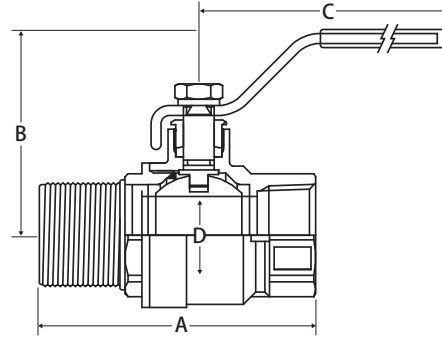

- Gland follower and single o-ring stem design
- Blow-out proof stem
- 100% leak tested

PART NUMBER	SIZE	A	B	C	D
100-131	1/4"	2.05	1.69	3.54	0.39
100-132	3/8"	2.13	1.69	3.54	0.39
100-133	1/2"	2.50	1.81	3.54	0.59
100-134	3/4"	3.00	2.12	4.55	0.75
100-135	1"	3.27	2.25	4.55	0.98

VALVE SEAT RATINGS

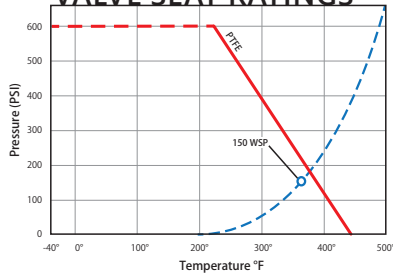

HPBFV SERIES 600 - LUG TYPE - 150 CLASS

LUG STYLE • STAINLESS (SS) OR CARBON STEEL (CS) BODY • STAINLESS STEEL DISC

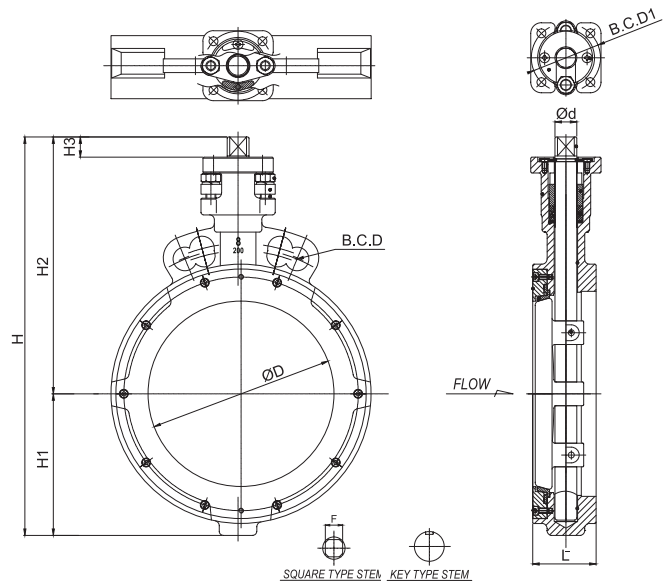

Basic Design: API 609, MSS-SP-68, BS 5155, ISO 5752
 Pressure / Temp Rating : ANSI B16.34
 Shell/Seat Test: API 598, MSS-SP-61

- Bubble-tight shut-off design
- Dual offset disc design
- Seat available in either RTFE or Metal
- One-piece stem in A564 Gr.630 / PH 17-4
- ISO 5211 mounting pad with a square shaft for 2-12 inches
- Key type connection ranging from 14-24 inches

- Excellent corrosion resistance via a one-piece body material of either cast or stainless steel
- Tight gland packing flange to prevent uneven load distribution against packing
- Internal stop design to prevent the disc from overtravelling, minimizing possible seat damage
- Heavy duty handle and 10 position notch plate on the valve disc for precise angle stops

PTFE & RPTFE Seat

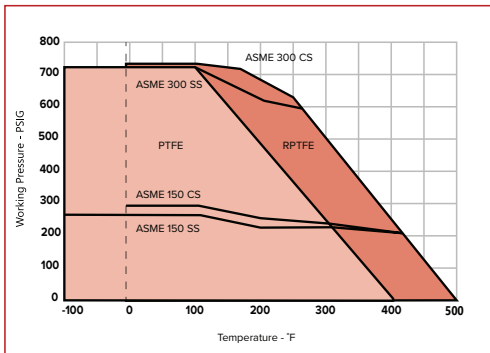

Metal Seat, 150 Class

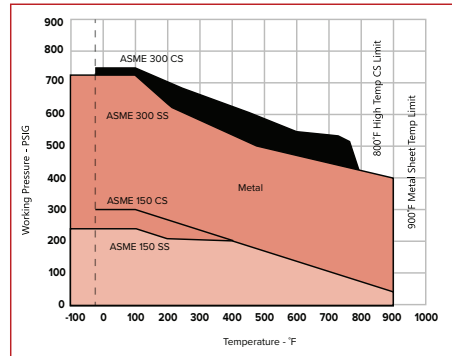

CS PART NUMBER	SS PART NUMBER	SIZE	H	H1	H2	H3	Ød	F	ØD	E	L	B.C.D	N	H
600-02H1CSRL	600-02H1SSRL	2"	8.63	2.36	6.27	0.60	0.51	0.43	1.65	F07	1.73	4.75	4	0.75
600-212H1CSRL	600-212H1SSRL	2-1/2"	9.54	2.76	6.78	0.60	0.63	0.55	2.40	F07	1.81	5.50	4	0.75
600-03H1CSRL	600-03H1SSRL	3"	9.85	3.01	6.84	0.60	0.63	0.55	2.91	F07	1.89	6.00	4	0.75
600-04H1CSRL	600-04H1SSRL	4"	11.07	3.54	7.53	0.70	0.63	0.55	3.70	F07	2.13	7.50	8	0.75
600-05H1CSR	600-05H1SSRB	5"	12.55	4.09	8.45	0.70	0.71	0.55	4.65	F07	2.24	8.50	8	0.87
600-06H1CSR	600-06H1SSRB	6"	13.62	4.53	9.09	0.75	0.87	0.67	5.51	F07	2.28	9.50	8	0.87
600-08H1CSR	600-08H1SSRG	8"	15.91	5.65	10.26	0.81	0.87	0.67	7.40	F07	2.52	11.75	8	0.87
600-10H1CSR	600-10H1SSRG	10"	18.44	6.69	11.75	0.81	1.10	0.87	9.39	F10	2.81	14.25	12	1.00
600-12H1CSR	600-12H1SSRG	12"	20.63	7.76	12.88	0.95	1.10	0.87	11.02	F10	2.81	17.00	12	1.00
600-14H1CSR	600-14H1SSRG	14"	26.87	11.00	15.87	2.76	1.50	-	-	F14	3.62	18.75	12	1.13
600-16H1CSR	600-16H1SSRG	16"	31.66	12.54	19.12	3.48	1.77	-	-	F16	4.02	21.75	16	1.13
600-18H1CSR	600-18H1SSRG	18"	33.73	13.31	20.41	3.48	2.17	-	-	F16	4.49	22.75	16	1.25
600-20H1CSR	600-20H1SSRG	20"	34.59	14.17	20.41	3.48	2.17	-	-	F16	5.00	25.00	20	1.25
600-24H1CSR	600-24H1SSRG	24"	39.76	16.70	23.05	3.68	2.56	-	-	F16	6.06	29.50	20	1.37

HPBFV SERIES 600 - LUG TYPE - 300 CLASS

LUG STYLE • STAINLESS (SS) OR CARBON STEEL (CS) BODY • STAINLESS STEEL DISC

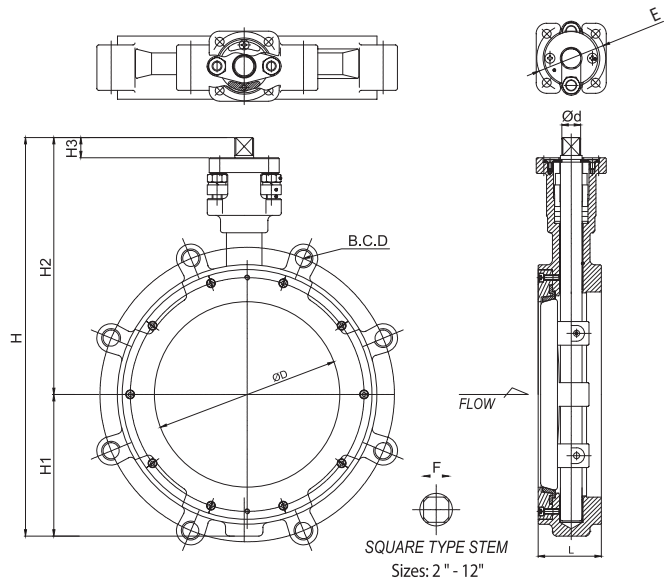
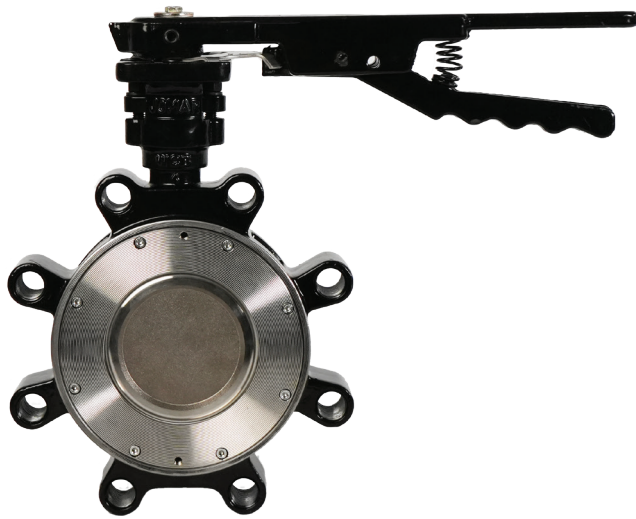

Basic Design: API 609, MSS-SP-68, BS 5155, ISO 5752
Pressure / Temp Rating : ANSI B16.34
Shell/Seat Test: API 598, MSS-SP-61

- Bubble-tight shut-off design
- Dual offset disc design
- Durable one-piece stem in A564 Gr.630 / PH 17-4
- ISO 5211 mounting pad with a square shaft for 2-12 inches
- Excellent corrosion resistance via a one-piece body material of either cast or stainless steel
- Tight gland packing flange to prevent uneven load distribution against packing
- Internal stop design to prevent the disc from overtravelling, minimizing possible seat damage
- Heavy duty handle and 10 position notch plate on the valve disc for precise angle stops

PTFE & RPTFE Seat

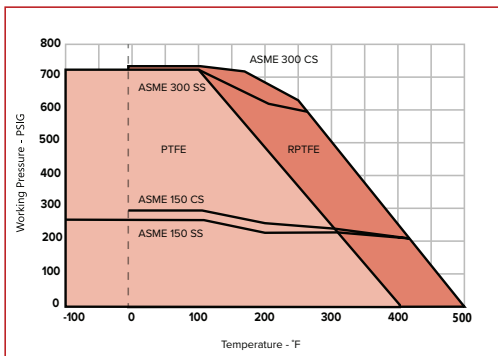

CS PART NUMBER	SS PART NUMBER	SIZE	H	H1	H2	H3	Ød	F	ØD	E	L	B.C.D	N*	H*	BOLT SIZE
600-02H3CSRL	600-02H3SSRL	2"	8.63	2.36	6.27	0.60	0.51	0.43	1.65	F07	1.73	5.00	8	0.75	5/8" X 1-1/2"
600-212H3CSRL	600-212H3SSRL	2-1/2"	9.54	2.76	6.77	0.60	0.63	0.55	2.40	F07	1.81	5.87	8	0.87	3/4" X 1-3/4"
600-03H3CSRL	600-03H3SSRL	3"	9.85	3.01	6.84	0.60	0.63	0.55	2.91	F07	1.89	6.63	8	0.87	3/4" X 1-3/4"
600-04H3CSRL	600-04H3SSRL	4"	11.07	3.54	7.53	0.70	0.63	0.55	3.70	F07	2.13	7.87	8	0.87	3/4" X 2-1/4"
600-02H3CSRG	600-02H3SSRG	2"	8.63	2.36	6.27	0.60	0.51	0.43	1.65	F07	1.73	5.00	8	0.75	5/8" X 1-1/2"
600-212H3CSRG	600-212H3SSRG	2-1/2"	9.54	2.76	6.77	0.60	0.63	0.55	2.40	F07	1.81	5.87	8	0.87	3/4" X 1-3/4"
600-03H3CSRG	600-03H3SSRG	3"	9.85	3.01	6.84	0.60	0.63	0.55	2.91	F07	1.89	6.63	8	0.87	3/4" X 1-3/4"
600-04H3CSRG	600-04H3SSRG	4"	11.07	3.54	7.53	0.70	0.63	0.55	3.70	F07	2.13	7.87	8	0.87	3/4" X 2-1/4"
600-05H3CSRG	600-05H3SSRG	5"	12.55	4.09	8.45	0.70	0.71	0.55	4.65	F07	2.24	9.25	8	0.87	3/4" X 2-1/4"
600-06H3CSRG	600-06H3SSRG	6"	13.62	4.53	9.09	0.75	0.91	0.67	5.51	F07	2.28	10.63	12	0.87	3/4" X 2-1/2"
600-08H3CSRG	600-08H3SSRG	8"	15.91	5.65	10.26	0.81	1.10	0.87	7.40	F10	2.87	13.00	12	1.00	7/8" X 2-7/8"
600-10H3CSRG	600-10H3SSRG	10"	18.44	6.69	11.75	0.81	1.10	0.87	9.39	F10	3.25	15.25	16	1.13	7/8" X 3-1/4"
600-12H3CSRG	600-12H3SSRG	12"	20.71	7.83	12.88	0.95	1.10	0.87	11.02	F10	3.62	17.75	16	1.25	1-1/8" X 3-1/2"

N* = number of bolts
H* = bolt hole diameter

BUTTERFLY VALVES



BFV SERIES 600 - LUG TYPE ^{NSF 61 & 372} LUG STYLE • EPOXY-COATED DUCTILE IRON BODY • STAINLESS STEEL DISC

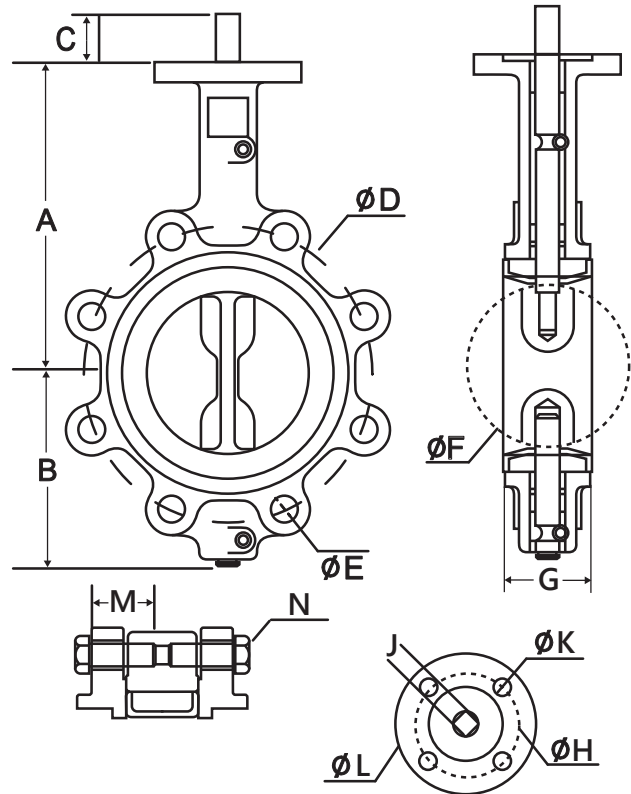

- Epoxy coated finish
- Square stem for direct mount
- bidirectional for dead end service
- Available in EPDM, PTFE, Buna-N, or Viton® seats
- Ideal for mounting pneumatic/electrical actuators
- Easily accepts actuator with ISO 5211 mounting flange
- Seat to flange seal eliminates the need for flange gaskets
- Designed for commercial and industrial applications up to 225 PSI
- Wetted surfaces contain less than .25% lead content

SEAT TEMPERATURE RANGES					
	SIZE	BUNA-N	EPDM	VITON	PTFE
TEMPERATURE RANGE (°F)	2" - 36"	10 TO 180	-30 TO 250	10 TO 275	-20 TO 250
INLINE SERVICE (PSI)	2" - 12"	200	200	200	200
	14" - 36"	150	150	150	150
DEAD END SERVICE W/DOWN STREAM FLANGE (PSI)	2" - 12"	200	200	200	100
DEAD END SERVICE W/O DOWN STREAM FLANGE (PSI)	2" - 12"	100	100	100	50

PART NUMBER	SIZE	A	B	C	D	E	F	G	H	J	K	L	M	N	WEIGHT
600-02DS_L	2"	6.34	3.15	1.26	4.74	4 : 5/8"	2.07	1.65	1.97	0.35	4 : 0.28	3.03	1.50	5/8-11UNC	8.38
600-212DS_L	2-1/2"	6.89	3.50	1.26	5.50	4 : 5/8"	2.54	1.77	1.97	0.35	4 : 0.28	3.03	1.50	5/8-11UNC	9.26
600-03DS_L	3"	7.13	3.74	1.26	6.00	4 : 5/8"	3.10	1.77	1.97	0.35	4 : 0.28	3.03	1.50	5/8-11UNC	10.36
600-04DS_L	4"	7.87	4.49	1.26	7.50	8 : 5/8"	4.09	2.03	2.76	0.43	4 : 0.35	3.54	1.75	5/8-11UNC	19.84
600-05DS_L	5"	8.39	5.00	1.26	8.50	8 : 3/4"	4.85	2.17	2.76	0.55	4 : 0.35	3.54	1.75	3/4-10UNC	24.03
600-06DS_L	6"	8.90	5.47	1.26	9.51	8 : 3/4"	6.13	2.17	2.76	0.55	4 : 0.35	3.54	2.00	3/4-10UNC	31.31
600-08DS_B	8"	10.24	6.89	1.61	11.75	8 : 3/4"	7.97	2.36	4.02	0.67	4 : 0.47	4.92	2.00	3/4-10UNC	40.12
600-10DS_B	10"	11.50	7.99	1.61	14.25	12 : 7/8"	9.86	2.64	4.02	0.87	4 : 0.47	4.92	2.25	7/8-9UNC	59.08
600-12DS_B	12"	13.27	9.53	1.61	17.01	12 : 7/8"	11.87	2.97	4.02	0.87	4 : 0.47	5.51	2.50	7/8-9UNC	88.18
600-14DS_G	14"	14.49	10.55	1.77	18.74	12 : 1"	13.12	2.97	4.02	0.87	4 : 0.47	5.51	2.50	1-8UNC	123.46
600-16DS_G	16"	15.75	12.17	2.02	21.26	16 : 1"	15.34	4.02	5.51	1.06	4 : 0.71	7.76	3.00	1-8UNC	211.64
600-18DS_G	18"	16.54	12.91	2.02	22.76	16 : 1-1/8"	17.34	4.49	5.51	1.06	4 : 0.71	7.76	3.50	1-1/8-7UNC	268.96
600-20DS_G	20"	18.90	14.21	2.53	25.00	20 : 1-1/8"	19.35	5.00	5.51	1.42	4 : 0.71	7.76	4.00	1-1/8-7UNC	445.33
600-24DS_G	24"	22.13	18.07	2.76	29.51	20 : 1-1/4"	23.33	5.94	6.50	1.42	4 : 0.91	10.87	4.50	1-1/4-7UNC	595.25
600-30DS_G	30"	25.98	21.22	-	-	-	29.30	-	-	-	-	-	-	-	939.17
600-36DS_G	36"	28.35	25.83	-	-	-	34.04	-	-	-	-	-	-	-	1604.96

*U-type Butterfly Valve, dimensions and drawings available upon request.

When ordering butterfly valves please specify the seat in the _ space with the following letter designations:
When ordering butterfly valves please specify the handle with the following letter designations:

E = EPDM	P = PTFE	V = VITON	B = BUNA
L = LEVER	B = BARE	G = GEAR	-
HANDLE	STEM	OPERATOR	

BFV SERIES 900 - WAFER TYPE NSF 61 & 372 WAFER STYLE • EPOXY-COATED DUCTILE IRON BODY • STAINLESS STEEL DISC

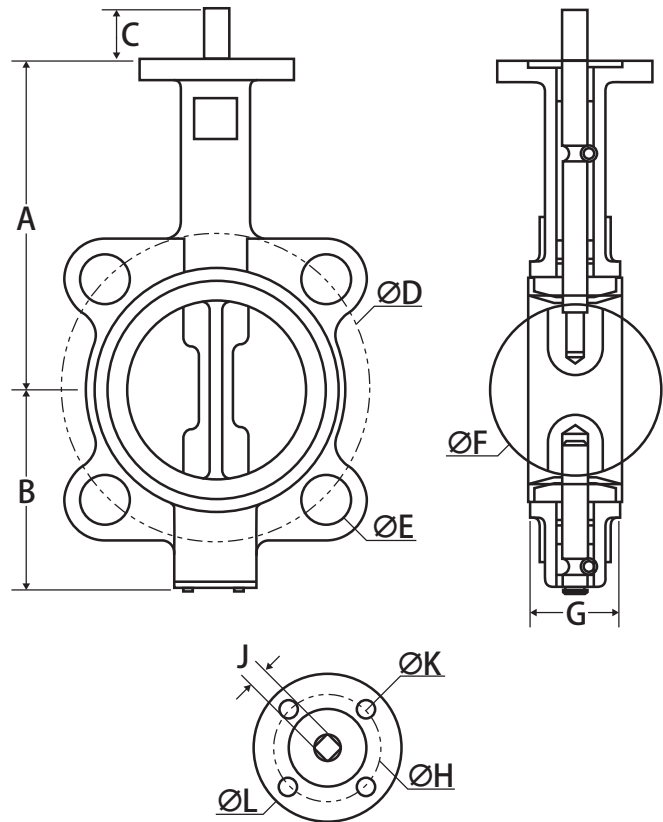

- Designed for commercial and industrial applications up to 225 PSI
- Easily accepts actuator with ISO 5211 mounting flange
- Available in EPDM, PTFE, Buna-N, or Viton® seats
- Meets API 609 & MSS SP-67
- Seat to flange seal eliminates the need for flange gaskets
- Epoxy coated finish
- Ideal for mounting pneumatic/electrical actuators
- Square stem for direct mount
- Wetted surfaces contain less than .25% lead content

	SEAT TEMPERATURE RANGES				
	SIZE	BUNA-N	EPDM	VITON	PTFE
TEMPERATURE RANGE (°F)	2" - 36"	10 to 180	-30 to 250	10 to 275	-20 to 250
INLINE SERVICE (PSI)	2" - 12"	200	200	200	200
	14" - 36"	150	150	150	150

PART NUMBER	SIZE	A	B	C	D	E	F	G	H	J	K	L	WEIGHT
900-02DS_L	2"	6.34	3.15	1.26	4.74	4 : 0.75	2.07	1.65	1.97	0.35	4 : 0.28	3.03	5.51
900-212DS_L	2-1/2"	6.89	3.50	1.26	5.50	4 : 0.75	2.54	1.77	1.97	0.35	4 : 0.28	3.03	7.05
900-03DS_L	3"	7.13	3.74	1.26	6.00	4 : 0.75	3.10	1.77	1.97	0.35	4 : 0.28	3.03	8.38
900-04DS_L	4"	7.87	4.49	1.26	7.50	8 : 0.75	4.09	2.03	2.76	0.43	4 : 0.35	3.54	10.80
900-05DS_L	5"	8.39	5.00	1.26	8.50	8 : 0.87	4.85	2.17	2.76	0.55	4 : 0.35	3.54	15.43
900-06DS_L	6"	8.90	5.47	1.26	9.51	8 : 0.87	6.13	2.17	2.76	0.55	4 : 0.35	3.54	17.20
900-08DS_B	8"	10.24	6.89	1.61	11.75	8 : 0.87	7.97	2.36	4.02	0.67	4 : 0.47	4.92	29.10
900-10DS_B	10"	11.50	7.99	1.61	14.25	12 : 0.98	9.86	2.64	4.02	0.87	4 : 0.47	4.92	42.33
900-12DS_B	12"	13.27	9.53	1.61	17.01	12 : 0.98	11.87	2.97	4.02	0.87	4 : 0.47	5.51	71.65
900-14DS_G	14"	14.49	10.51	1.77	18.74	12 : 1.14	13.12	2.97	4.02	0.87	4 : 0.47	5.51	91.05
900-16DS_G	16"	15.75	12.17	2.02	21.26	16 : 1.14	15.34	4.02	5.51	1.06	4 : 0.71	7.76	134.48
900-18DS_G	18"	16.61	12.91	2.02	22.76	16 : 1.26	17.34	4.49	5.51	1.06	4 : 0.71	7.76	174.16
900-20DS_G	20"	18.90	14.21	2.53	25.00	20 : 1.26	19.35	5.00	5.51	1.42	4 : 0.71	7.76	282.19
900-24DS_G	24"	22.13	18.07	2.76	29.51	20 : 1.38	23.33	5.94	6.50	1.42	4 : 0.91	10.87	414.47
900-30DS_G	30"	25.98	21.22	2.60	36.00	28 : 1.38	29.30	-	10.00	-*	8 : 0.71	11.81	723.12
900-36DS_G	36"	28.35	25.83	4.65	41.34	32 : 1.61	34.04	-	10.00	-*	8 : 0.71	11.81	1571.89

*Stem is round with key, dimensions and drawings available upon request.

When ordering butterfly valves please specify the seat in the _ space with the following letter designations:
 When ordering butterfly valves please specify the handle with the following letter designations:

E = EPDM	P = PTFE	V = VITON	B = BUNA
L = LEVER HANDLE	B = BARE STEM	G = GEAR OPERATOR	-

BUTTERFLY HANDLES

LEVER HANDLE TEN-POSITION LOCKABLE LEVER HANDLE

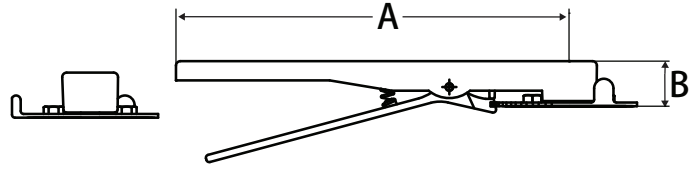

PART NUMBER	SIZE	A	B
BLH2-3	2" - 3"	10.51	1.18
BLH4	4"	10.51	1.18
BLH5-6	5" - 6"	10.51	1.18
BLH8	8"	14.06	0.98
BLH10	10"	14.06	0.98
BLH12	12"	14.06	0.98

GEAR OPERATOR HANDLE BUTTERFLY GEAR OPERATOR

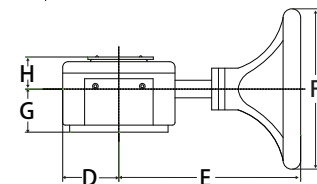
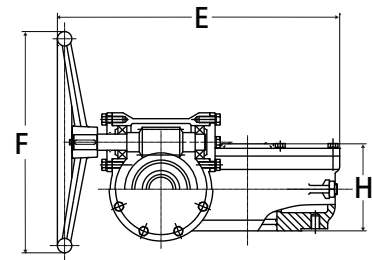
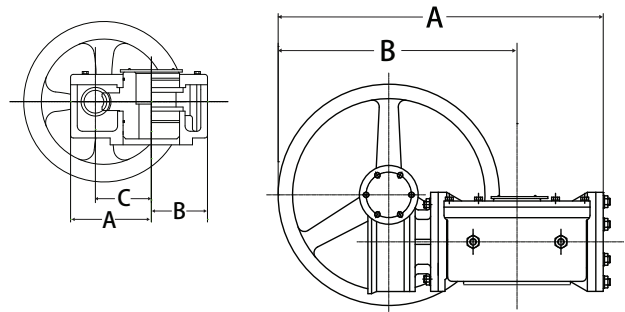

PART NUMBER	SIZE	A	B	C	D	E	F	G	H
2"-14"									
BGO2-3	2"-3"	4.72	2.01	1.77	2.01	6.06	5.90	1.53	1.77
BGO4	4"	4.72	2.01	1.77	2.01	6.06	5.90	1.53	1.77
BGO5-6	5"-6"	4.72	2.01	1.77	2.01	6.06	5.90	1.53	1.77
BGO8	8"	7.99	2.79	2.60	2.79	8.82	11.22	1.46	2.16
BGO10	10"	7.99	2.79	2.60	2.79	8.82	11.22	1.46	2.16
16"-36"									
BGO16-18	16"-18"	16.53	12.28	-	-	14.37	11.22	-	5.03
BGO20	20"	16.53	12.28	-	-	14.37	11.22	-	5.03
BGO24	24"	20.47	15.27	-	-	16.38	15.16	-	5.51
BGO30	30"	23.42	17.44	-	-	19.01	16.73	-	5.87
BGO36	36"	29.88	19.37	-	-	23.62	16.73	-	7.28

HPBFV LEVER HANDLE

TEN-POSITION, HIGH PERFORMANCE LOCKABLE LEVER HANDLE



PART NUMBER	SIZE
HPBFV 150 CLASS	
HPLH2	2"
HPLH2.5-5	2-1/2", 3", 4", 5"
HPLH6	6"
HPBFV 300 CLASS	
HPLH2	2"
HPLH2.5-5	2-1/2", 3", 4"

HPBFV LEVER HANDLE - STAINLESS STEEL

TEN-POSITION, HIGH PERFORMANCE LOCKABLE LEVER HANDLE

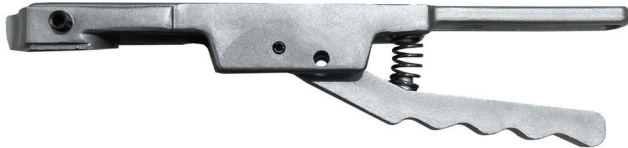

PART NUMBER	SIZE
HPBFV 150 CLASS	
HPLH2SS	2"
HPLH2.5-5SS	2-1/2", 3", 4", 5"
HPLH6SS	6"
HPBFV 300 CLASS	
HPLH2SS	2"
HPLH2.5-5SS	2-1/2", 3", 4"

LEAD FREE ADD-A-VALVE



EMERGENCY SHUT OFF DEVICE



- Eliminates facility shutdowns
- Bottom clean-out cap serves as full port line tap
- Lead free sweat ball valve included in package
- Loctite® 518 gasket sealant included
- U.S. and Canadian patent no. 5,316,037

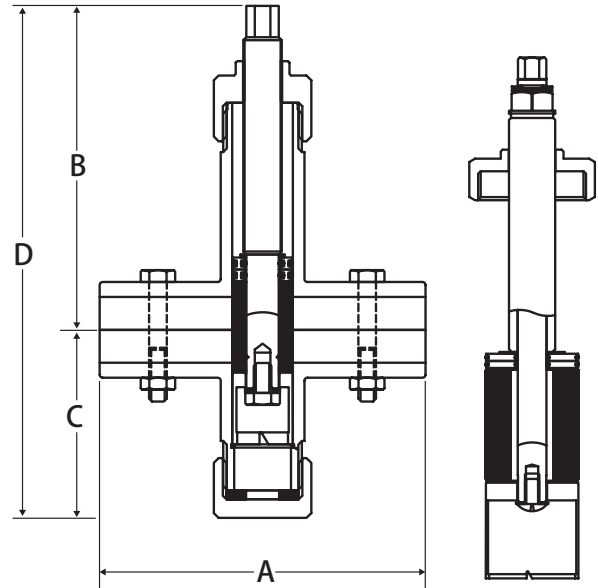

PART NUMBER	SIZE	A	B	C	D (OPEN)	D (CLOSED)
800-103ADDG	1/2"	2.99	5.08	1.61	6.69	5.12
800-104ADDG	3/4"	3.31	6.30	2.48	8.78	6.77
800-105ADDG	1"	3.66	7.48	2.80	10.28	7.68
800-106ADDG	1-1/4"	4.25	9.77	2.80	12.72	9.77
800-107ADDG	1-1/2"	4.65	10.43	3.58	13.86	10.43
800-108ADDG	2"	7.20	12.17	3.98	16.61	12.17

F-351

CAST IRON GATE VALVE • BOLTED BONNET • NON-RISING STEM • SOLID WEDGE • CLASS 125

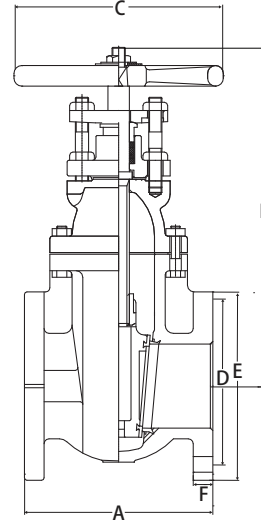

- Lead Free Compliant
- Conforms to MSS SP-70
- Flange: ANSI B16.1
- Face to Face: ANSI B16.10

Pressure Rating

- Class 125
- Suitable for 125 PSI WSP

PART NUMBER	SIZE	A	B	C	D	E	F
103-525	2-1/2"	7.50	12.72	7.01	5.51	7.01	0.69
103-503	3"	8.00	13.31	7.87	6.00	7.48	0.76
103-504	4"	9.00	16.18	10.00	7.48	8.98	0.92
103-506	6"	10.50	21.97	11.81	9.48	10.98	1.00
103-508	8"	11.50	25.59	13.70	11.75	13.50	1.12

F-361

CAST IRON GATE VALVE • BOLTED BONNET • SOLID WEDGE • OS & Y • CLASS 125

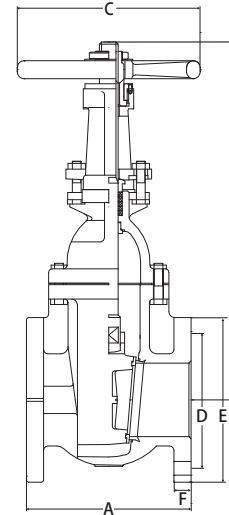

- Lead Free Compliant
- Conforms to MSS SP-70
- Flange: ANSI B16.1
- Face to Face: ANSI B16.10

Pressure Rating

- Class 125
- Suitable for 125 PSI WSP

PART NUMBER	SIZE	A	B	C	D	E	F
103-625	2-1/2"	7.50	16.93	7.01	5.49	7.01	0.81
103-603	3"	8.00	19.09	7.87	6.00	7.52	0.88
103-604	4"	9.00	24.21	10.00	7.48	9.01	0.92
103-606	6"	10.50	32.88	11.82	9.51	10.98	1.00
103-608	8"	11.50	39.76	13.70	11.76	13.50	1.13
103-610	10"	13.00	48.03	15.75	14.25	15.98	1.19
103-612	12"	14.02	56.50	17.00	17.01	19.01	1.25

T-301

BRASS GATE VALVE • NON-RISING STEM • THREADED CONNECTION • 200 WOG

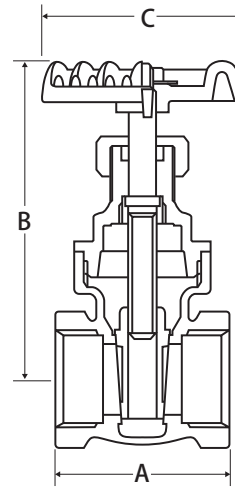

- Manufactured in ISO-9001 facility
- Solid wedge gate
- Residential and commercial applications

VALVE SEAT RATINGS

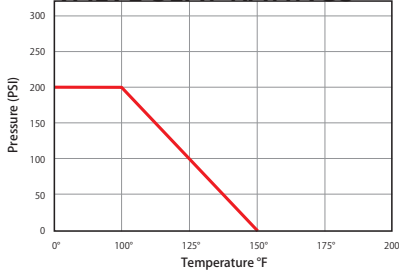

PART NUMBER	SIZE	A	B	C
100-303	1/2"	1.69	2.84	2.13
100-304	3/4"	1.85	3.31	2.13
100-305	1"	2.17	3.94	2.52
100-306	1-1/4"	2.40	4.57	2.75
100-307	1-1/2"	2.52	4.84	3.07
100-308	2"	2.83	5.90	3.54
100-309	2-1/2"	3.51	7.33	4.14
100-310	3"	3.98	8.75	5.12
100-311	4"	4.57	10.17	6.78

S-301

BRASS GATE VALVE • NON-RISING STEM • SOLDER CONNECTION • 200 WOG

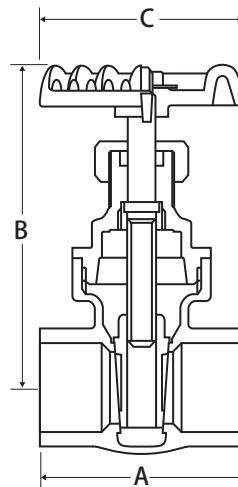

- Manufactured in ISO-9001 facility
- Solid wedge gate
- Residential and commercial applications

VALVE SEAT RATINGS

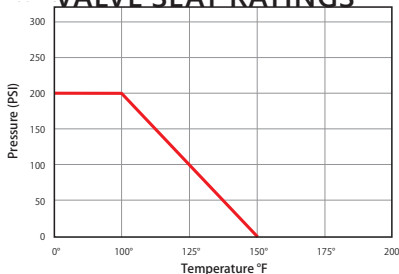

PART NUMBER	SIZE	A	B	C
100-403	1/2"	1.77	2.84	2.13
100-404	3/4"	2.32	3.31	2.13
100-405	1"	2.76	3.86	2.40
100-406	1-1/4"	2.88	4.57	3.03
100-407	1-1/2"	3.19	4.93	3.03
100-408	2"	3.90	6.03	3.27
100-409	2-1/2"	4.61	7.33	4.14
100-410	3"	5.20	8.75	5.12

F-651 Y-STRAINER

BOLTED BONNET • STAINLESS STEEL SCREEN • CLASS 125

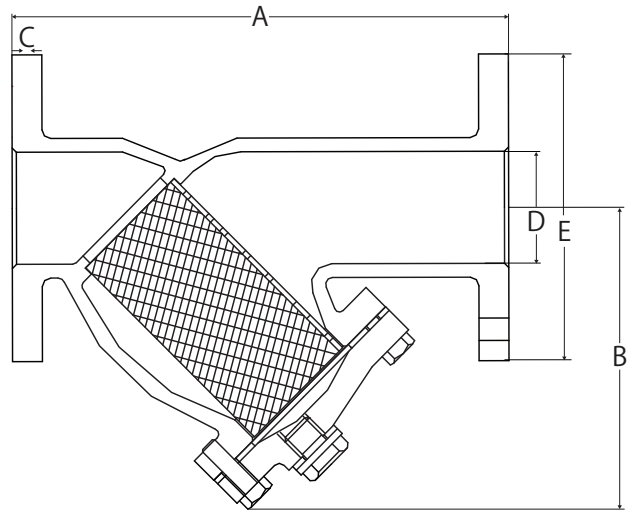

- Lead Free Compliant
- Flange: ANSI B16.1

Pressure Rating

- Class 125

PART NUMBER	SIZE	A	B	C	D	E
106-625	2-1/2"	10.75	6.81	0.69	2.56	7.01
106-603	3"	11.50	7.68	0.75	3.15	7.52
106-604	3"	13.86	8.86	0.94	3.94	9.01
106-606	6"	18.50	12.91	1.00	5.90	10.98
106-608	8"	21.38	16.73	1.14	7.87	13.50

F-571 CHECK VALVE

HORIZONTAL SWING • BOLTED BONNET • CLASS 125

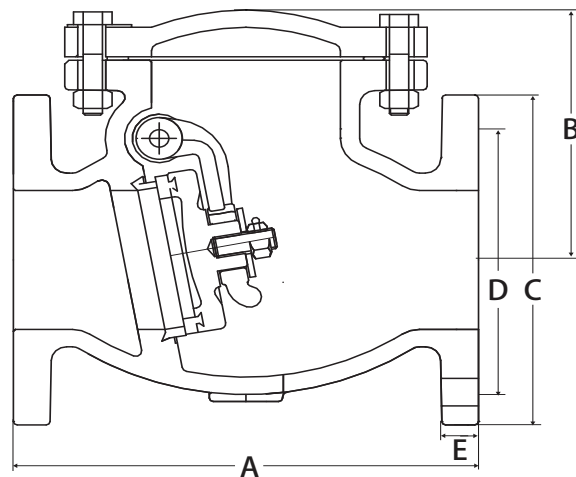

- Lead Free Compliant
- Conforms to MSS SP-71
- Flange: ASME B16.1
- Face to Face: ANSI B16.10

Pressure Rating

- Class 125
- Suitable for 125 PSI WSP

PART NUMBER	SIZE	A	B	C	D	E
105-725	2-1/2"	8.50	5.24	7.01	5.49	0.81
105-703	3"	9.50	5.67	7.52	6.00	0.88
105-704	4"	11.50	6.61	9.01	7.50	0.92
105-706	6"	14.00	8.54	10.98	9.51	1.00
105-708	8"	19.49	10.27	13.50	11.75	1.12
105-710	10"	24.49	11.30	15.98	14.25	1.19
105-712	12"	27.50	12.56	19.01	17.01	1.25

F-591 CHECK VALVE

WAFER STYLE • DOUBLE DOOR • ALUMINUM BRONZE DISC • CLASS 125

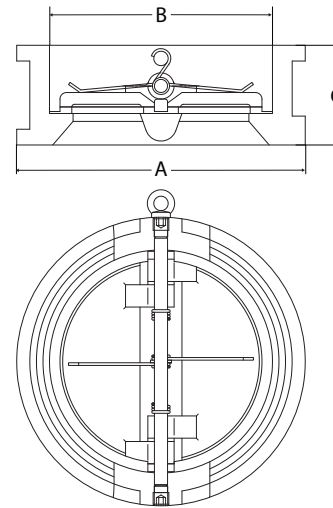

- Lead Free Compliant

Pressure Rating

- Class 125

PART NUMBER	SIZE	A	B	C	C _v
105-925	2-1/2"	4.88	3.15	2.17	120
105-903	3"	5.38	3.70	2.27	226
105-904	4"	6.88	4.61	2.52	404
105-906	6"	8.75	6.69	2.99	1075
105-908	8"	10.98	8.82	3.50	1920

T-501

HORIZONTAL SWING CHECK VALVE • THREADED CONNECTION • 200 WOG

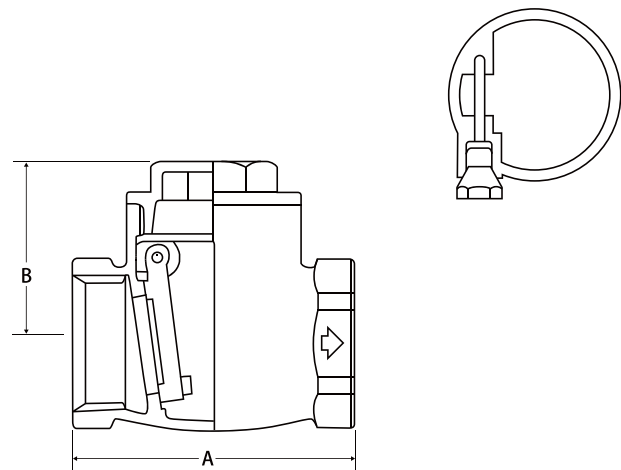

- Commercial and residential applications

Pressure Rating

- 200 WOG

PART NUMBER	SIZE	A	B
105-103	1/2"	2.13	1.54
105-104	3/4"	2.33	1.62
105-105	1"	2.72	1.77
105-106	1-1/4"	3.11	2.01
105-107	1-1/2"	3.51	2.25
105-108	2"	4.30	2.68
105-109	2-1/2"	5.32	3.35
105-110	3"	6.30	3.86
105-111	4"	7.49	4.53

T-511

BRONZE Y-PATTERN SWING CHECK VALVE • THREADED CONNECTION • 300 WOG • CLASS 150

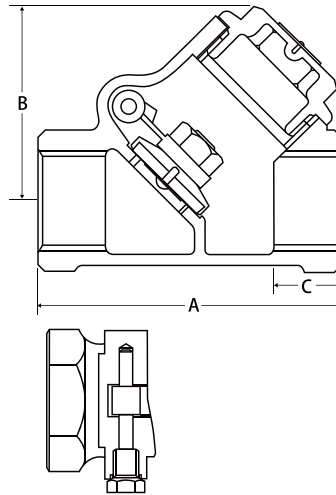

- Constructed of 85-5-5 Bronze
- Can be installed in vertical or horizontal position

PART NUMBER	SIZE	A	B	C
105-303	1/2"	2.36	1.77	0.54
105-304	3/4"	2.76	1.97	0.57
105-305	1"	3.40	2.28	0.70
105-306	1-1/4"	3.78	2.67	0.71
105-307	1-1/2"	4.57	2.95	0.75
105-308	2"	5.35	3.70	0.79
105-309	2-1/2"	6.72	4.65	1.14
105-310	3"	7.55	5.47	1.18

T-550

STAINLESS STEEL SWING CHECK VALVE • THREADED CONNECTION • 200 WOG

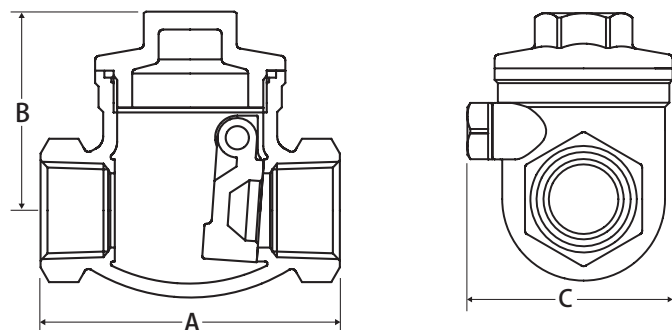

- Manufactured in ISO-9001 facility
- Heavy pattern body
- One-piece body design
- PTFE O-ring seal
- Metal to metal disc seal

PART NUMBER	SIZE	A	B	C
105-803	1/2"	2.56	1.73	1.83
105-804	3/4"	3.15	2.05	2.05
105-80	1"	3.50	2.44	2.20
105-806	1-1/4"	4.13	2.64	2.56
105-807	1-1/2"	4.72	3.11	2.95
105-808	2"	5.47	3.15	3.31

LEAD FREE CHECK VALVES



T-521G



LEAD FREE BRASS INLINE CHECK VALVE • THREADED CONNECTION • 300 WOG • CLASS 150

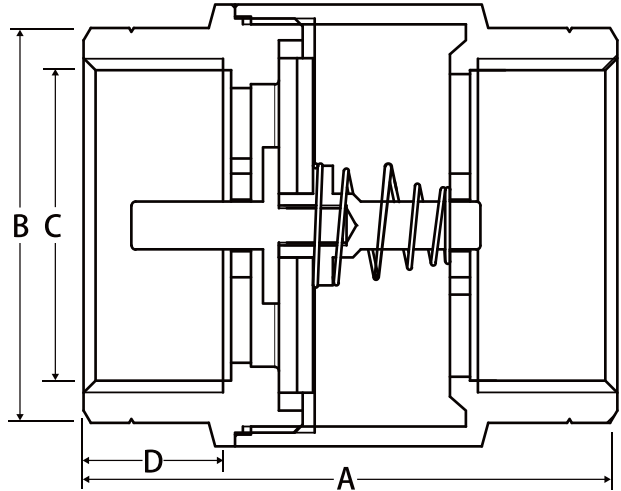

- Forged Lead Free Brass Body
 - Bubble tight Teflon seal
 - Wetted surfaces contain less than .25% lead content
- Pressure/Temperature Rating
- 300 WOG
 - Max. 250°F

PART NUMBER	SIZE	A	B	C	D
105-603G	1/2"	1.28	1.91	0.50	0.49
105-604G	3/4"	1.54	2.06	0.75	0.59
105-605G	1"	1.77	2.30	1.00	0.59
105-606G	1-1/4"	2.17	2.64	1.25	0.73
105-607G	1-1/2"	2.34	2.74	1.50	0.71
105-608G	2"	3.15	3.31	2.00	0.83

S-521G



LEAD FREE BRASS INLINE CHECK VALVE • SOLDER CONNECTION • 300 WOG • CLASS 150

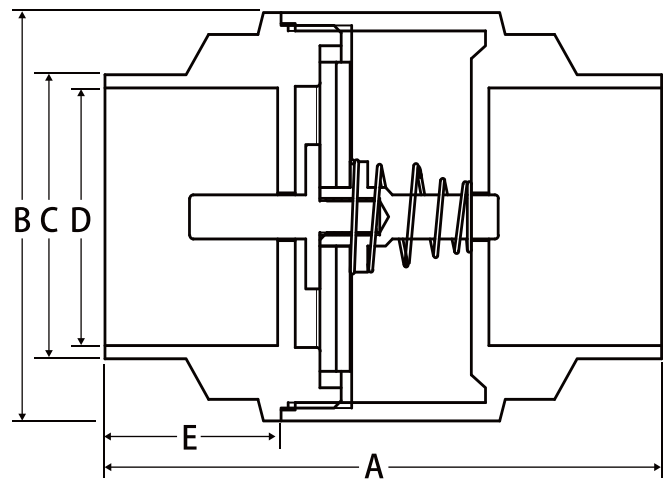

- Forged Lead Free Brass Body
 - Bubble tight Teflon seal
 - Wetted surfaces contain less than .25% lead content
- Pressure/Temperature Rating
- 300 WOG
 - Max. 250°F

PART NUMBER	SIZE	A	B	C	D	E
105-613G	1/2"	1.28	1.91	0.50	0.49	0.74
105-614G	3/4"	1.54	2.06	0.75	0.59	0.77
105-615G	1"	1.77	2.30	1.00	0.59	0.89
105-616G	1-1/4"	2.17	2.64	1.25	0.73	0.94
105-617G	1-1/2"	3.60	2.34	1.81	1.63	1.14
105-618G	2"	3.15	3.31	2.00	0.83	1.34

T-SS-1001N 2 PIECE • FULL PORT • THREADED CONNECTION • 1000 WOG



- Solid ball construction
- Latch lock handle, may be locked in open or closed positions
- 29 in-Hg vacuum rating
- 100% leak tested
- Wetted surfaces contain less than .25% lead content

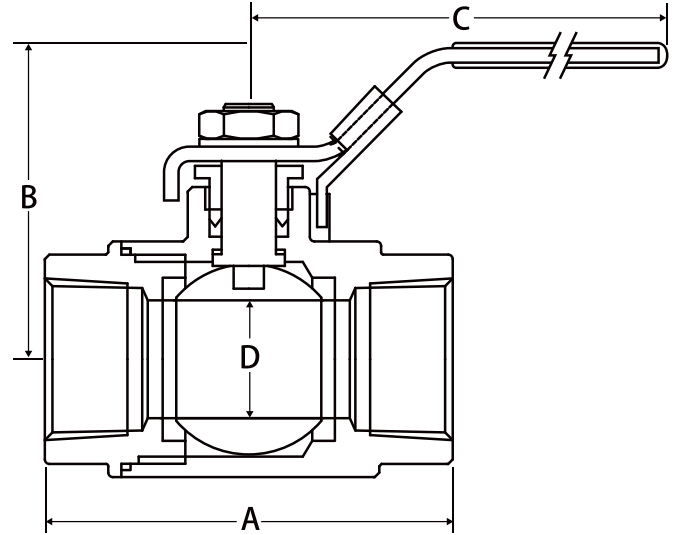

VALVE SEAT RATINGS

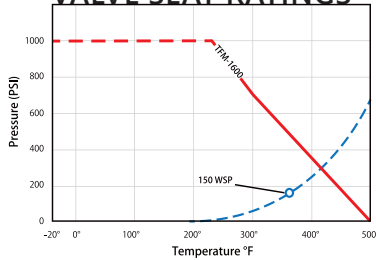

PART NUMBER	SIZE	A	B	C	D	TORQUE
100-961	1/4"	2.20	2.20	4.21	0.43	40
100-962	3/8"	2.20	2.20	4.21	0.43	40
100-963	1/2"	2.60	2.30	4.21	0.56	40
100-964	3/4"	2.99	2.79	5.73	0.81	60
100-965	1"	3.54	2.96	5.73	1.00	70
100-966	1-1/4"	3.94	3.56	7.45	1.25	110
100-967	1-1/2"	4.41	3.84	7.45	1.50	170
100-968	2"	5.00	4.24	8.08	1.97	250

T-SS-2000N 2 PIECE • STANDARD PORT • THREADED CONNECTION • 2000 WOG



- Solid ball construction
- Latch lock handle, may be locked in open or closed positions
- 29 in-Hg vacuum rating
- 100% leak tested
- Wetted surfaces contain less than .25% lead content

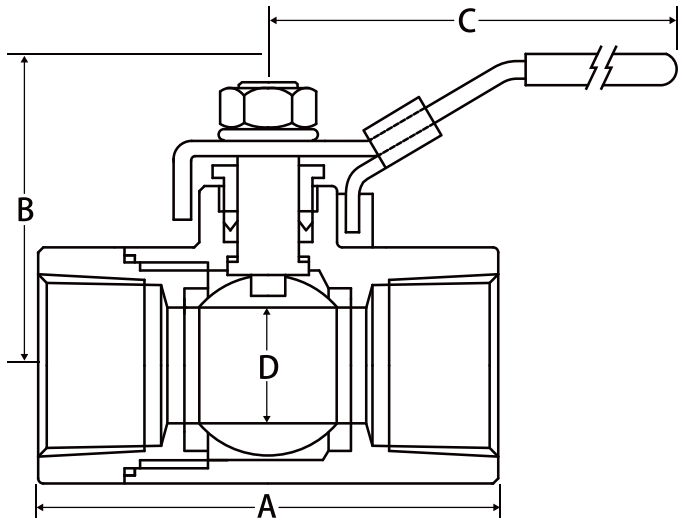

VALVE SEAT RATINGS

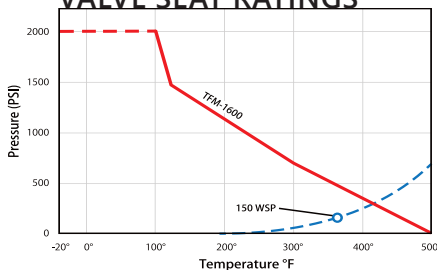

PART NUMBER	SIZE	A	B	C	D	TORQUE
100-931	1/4"	2.34	1.94	4.06	0.44	35
100-932	3/8"	2.34	1.94	4.06	0.49	35
100-933	1/2"	2.34	1.94	4.06	0.49	65
100-934	3/4"	2.63	2.21	4.06	0.59	100
100-935	1"	2.98	2.49	4.29	0.79	120
100-936	1-1/4"	3.49	3.08	5.71	0.98	210
100-937	1-1/2"	3.84	3.24	5.71	1.26	300
100-938	2"	4.80	3.66	7.09	1.50	400

STAINLESS STEEL BALL VALVES



T-SS-2000N-MF

2 PIECE • STANDARD PORT • MALE X FEMALE CONNECTION • 2000 WOG

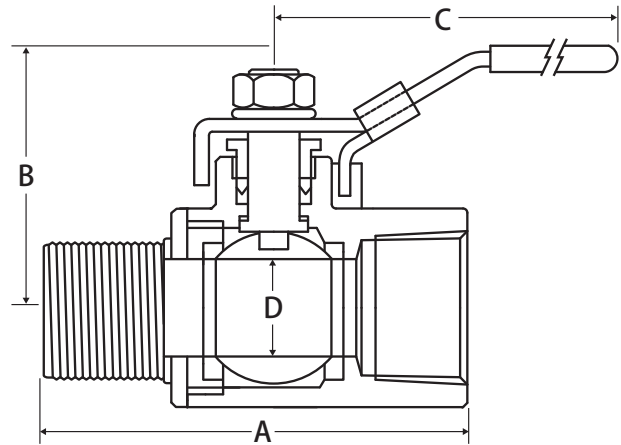

- Solid Ball Construction
- 29 in-Hg vacuum rating
- Latch lock may be locked in open or closed position
- 100% leak tested
- Wetted surfaces contain less than .25% lead content

PART NUMBER	SIZE	A	B	C	D	TORQUE
101-931	1/4"	2.44	1.75	4.06	0.38	35
101-933	1/2"	2.89	1.94	4.06	0.49	65
101-934	3/4"	3.26	2.21	4.06	0.59	100
101-935	1"	3.62	2.49	4.29	0.79	120

T-SS-1050N-3L

2 PIECE • REDUCED PORT • 3 WAY DISPENSER • THREADED CONNECTION • 1000 WOG

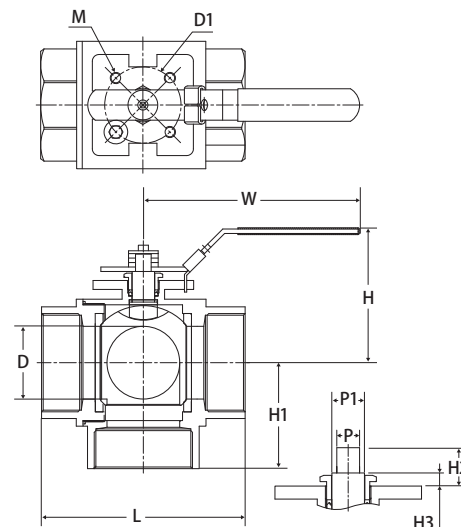

- Blowout proof stem
- Locking handle
- Antistatic device
- 180° handle prevents cross-contamination
- ISO 5211 mounting pad

PART NUMBER	SIZE	D	L	H	H1	H2	H3	W	P	P1	D1	M	TORQUE
500-203	1/2"	0.49	2.6	2.36	1.36	0.35	0.15	5.25	0.35	0.47	1.42	M5*0.8	62.1
500-204	3/4"	0.63	3.03	2.61	1.56	0.41	0.22	5.25	0.35	0.47	1.42	M5*0.8	82.8
500-205	1"	0.79	3.48	2.75	1.81	0.41	0.22	5.25	0.35	0.47	1.65	M5*0.8	138.1

Pressure/Temperature Rating

- 1000 WOG
- -4°F to 392°F

T-SS-900N
2 PIECE • FULL PORT • THREADED CONNECTION • 1000 WOG

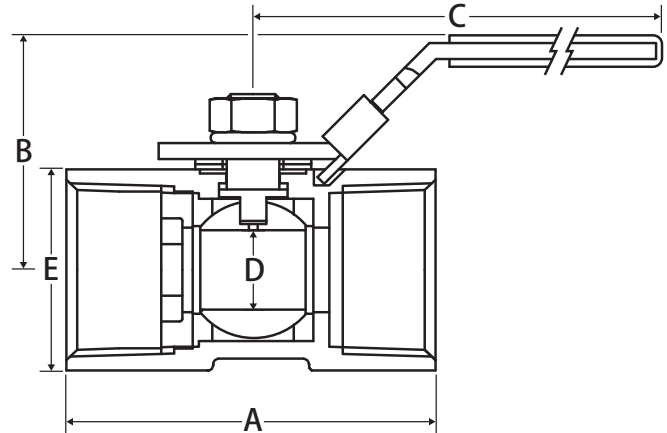

- Solid ball construction
- Latch lock handle, may be locked in open or closed positions
- 100% leak tested
- Wetted surfaces contain less than .25% lead content

VALVE SEAT RATINGS

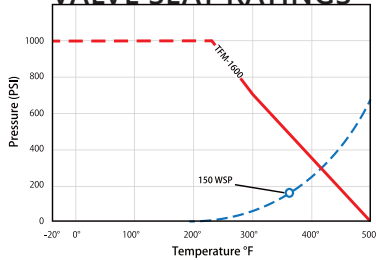

PART NUMBER	SIZE	A	B	C	D
100-903	1/2"	2.13	1.99	3.51	0.59
100-904	3/4"	2.30	2.19	3.94	0.79
100-905	1"	2.85	2.50	4.42	0.98
100-906	1-1/4"	3.27	2.93	5.48	1.26
100-907	1-1/2"	3.67	3.54	5.53	1.50
100-908	2"	4.18	3.54	6.10	1.97

STAINLESS STEEL BALL VALVES



T-SS-2000N-DH 
 THREADED CONNECTION • SPRING RETURN HANDLE

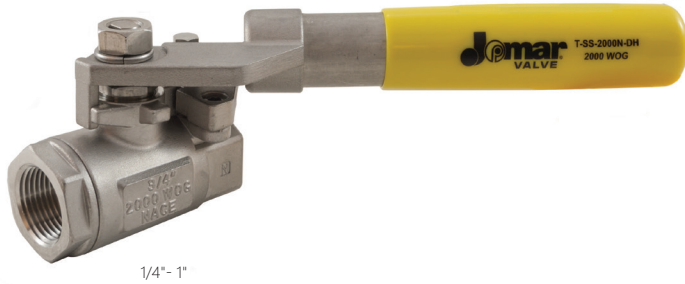

1/4" - 1"

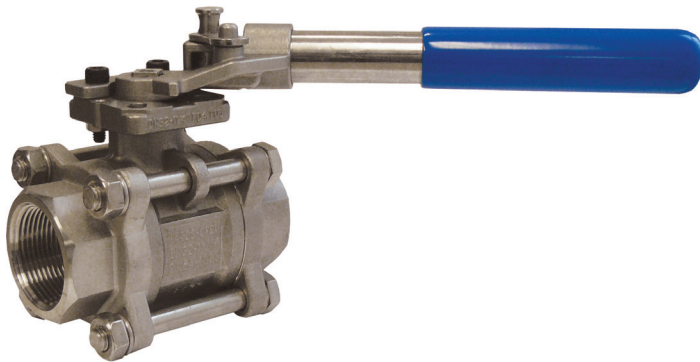

1-1/4" - 2"

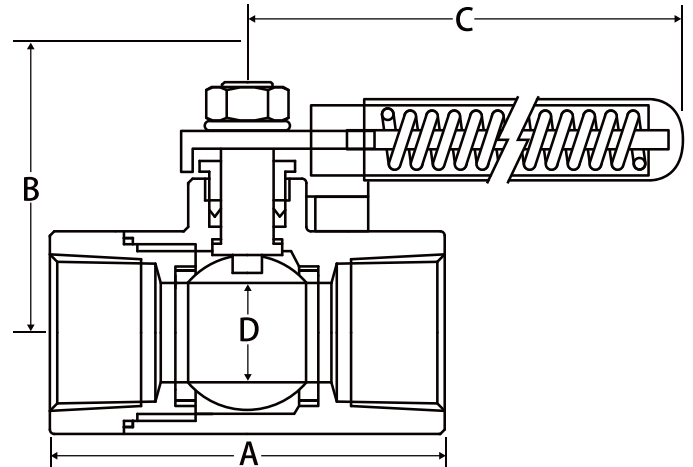

- Fail safe position
- Solid ball construction
- 29 in-Hg vacuum rating
- 100% leak tested
- Wetted surfaces contain less than .25% lead content

VALVE SEAT RATINGS

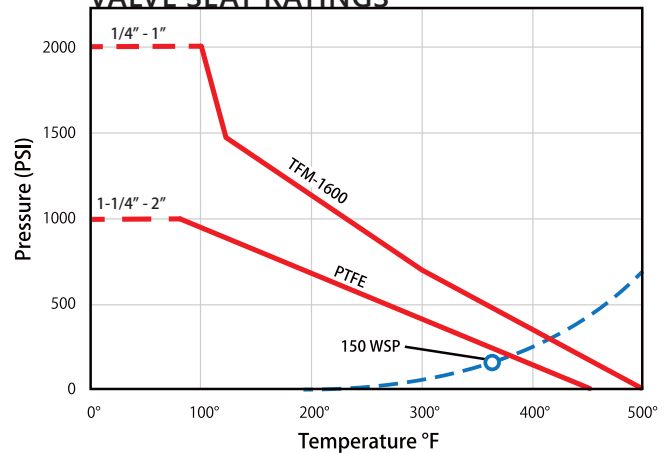

PART NUMBER	SIZE	PORT	WOG	NUMBER OF PIECES	BOLTS
100-931DH	1/4"	STANDARD	2000	2 PIECE	-
100-932DH	3/8"	STANDARD	2000	2 PIECE	-
100-933DH	1/2"	STANDARD	2000	2 PIECE	-
100-934DH	3/4"	STANDARD	2000	2 PIECE	-
100-935DH	1"	STANDARD	2000	2 PIECE	-
100-936DH	1-1/4"	FULL	1000	3 PIECE	4
100-937DH	1-1/2"	FULL	1000	3 PIECE	4
100-938DH	2"	FULL	1000	3 PIECE	4

A101-DH

2 PIECE • FULL PORT • THREADED CONNECTION • 600 WOG
STAINLESS STEEL BALL AND STEM WITH SPRING RETURN HANDLE

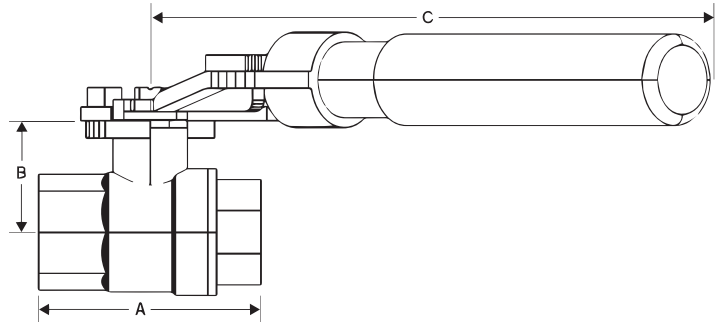

- Dezincification resistant alloy
- Blow out proof stem
- Fail safe position
- Handle may be locked in the closed position
- 100% leak tested
- Wetted surface contains less than .25% lead content

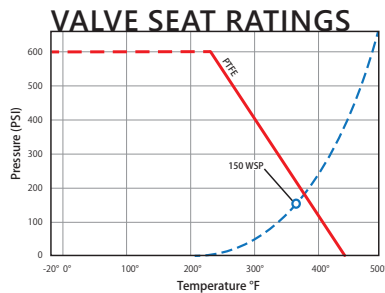

PART NUMBER	SIZE	A	B	C
A101-12DH	1/2"	2.39	1.14	6.69
A101-34DH	3/4"	2.57	1.28	6.69
A101-1DH	1"	2.97	1.59	8.66
A101-114DH	1-1/4"	3.44	1.82	8.66
A101-112DH	1-1/2"	3.88	2.32	8.66
A101-2DH	2"	4.29	2.62	8.66

T-SS-1000

1 PIECE / 2 PIECE • FULL PORT • THREADED CONNECTION • 1000 WOG

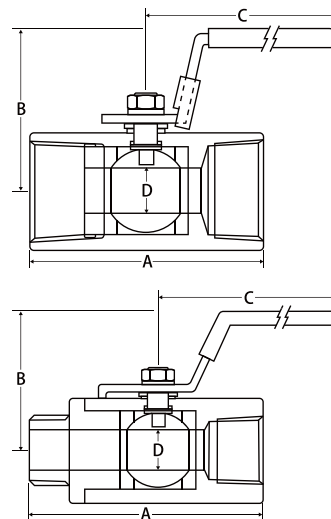

- Solid ball construction
- Corrosion resistant
- 29 in-Hg vacuum rating
- 100% leak tested
- Wetted surfaces contain less than .25% lead content

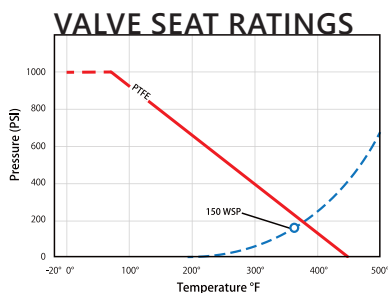

PART NUMBER	SIZE	A	B	C	D
500-098	1/8" FIP X 1/8" MIP	2.00	1.22	2.44	0.20
500-099	1/4" FIP X 1/4" MIP	2.32	1.50	3.45	0.30
500-101	1/4" FIP X 1/4" FIP	1.57	1.42	3.45	0.20

STAINLESS STEEL BALL VALVES



T-SS-1000N-4B



3 PIECE • 4 BOLT • SWING OUT BODY • FULL PORT • THREADED CONNECTION • 1000 WOG

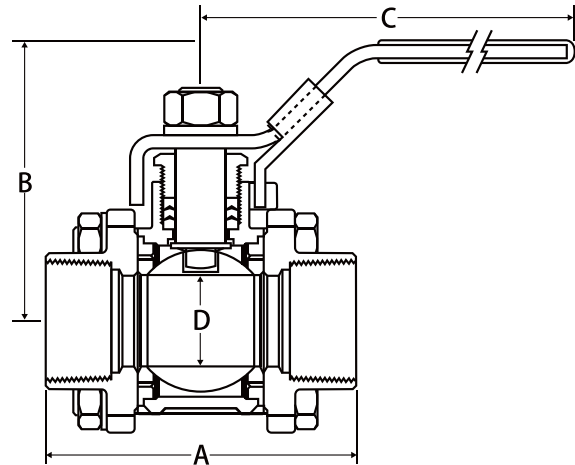

- Latch lock handle, may be locked in open or closed positions
- 29 in-Hg vacuum rating
- Repair kit available
- 100% leak tested
- Wetted surfaces contain less than .25% lead content

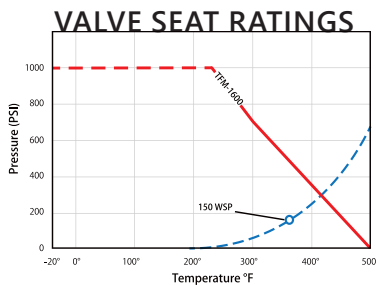

PART NUMBER	SIZE	A	B	C	D
500-301	1/4"	2.37	2.18	4.30	0.37
500-302	3/8"	2.37	2.18	4.30	0.37
500-303	1/2"	2.76	2.38	4.30	0.56
500-304	3/4"	3.03	2.87	5.81	0.81
500-305	1"	3.63	2.95	5.81	1.00
500-306	1-1/4"	4.14	3.66	7.44	1.25
500-307	1-1/2"	4.73	3.94	7.44	1.50
500-308	2"	5.43	4.25	7.81	1.97
500-310	3"	7.52	5.26	9.75	3.00
500-311	4"	8.54	6.57	11.88	3.93

S-SS-1000N-4B



3 PIECE • 4 BOLT • SWING OUT BODY • FULL PORT • SOCKET WELD • 1000 WOG

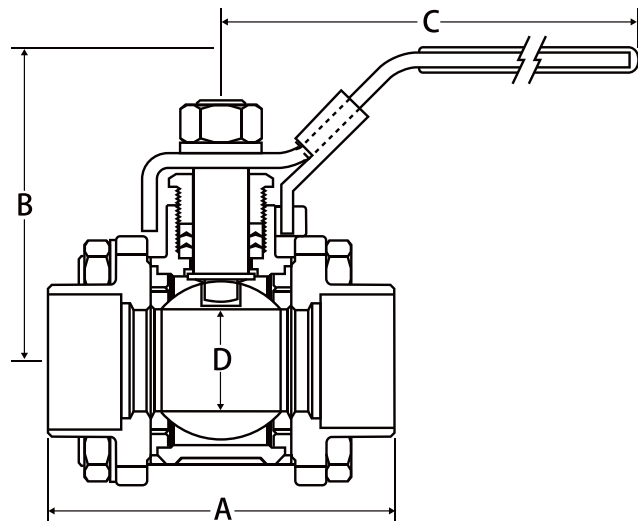

- Latch lock handle, may be locked in open or closed positions
- 29 in-Hg vacuum rating
- Repair kit available
- 100% leak tested
- Wetted surfaces contain less than .25% lead content

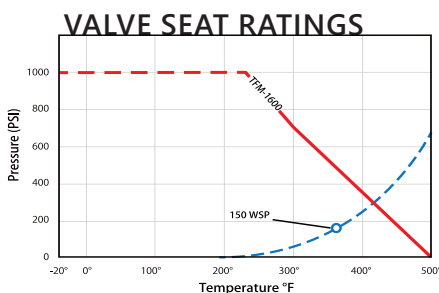

PART NUMBER	SIZE	A	B	C	D
500-343	1/2"	2.76	2.38	4.30	0.56
500-344	3/4"	3.03	2.87	5.81	0.81
500-345	1"	3.63	2.95	5.81	1.00
500-346	1-1/4"	4.14	3.66	7.44	1.25
500-347	1-1/2"	4.73	3.94	7.44	1.50
500-348	2"	5.43	4.25	7.81	1.97
500-350	3"	7.52	5.26	9.75	3.00
500-351	4"	8.54	6.57	11.88	3.93

T-SS-2001N-4B



3 PIECE 4 BOLT ENCLOSED • STANDARD PORT • THREADED CONNECTION • 2000 WOG



- Latch lock handle may be locked in open or closed position
- Solid ball construction
- Blow out proof stem
- 29 in-Hg vacuum rating
- Fire safe rated
- 100% leak tested
- Wetted surfaces contain less than .25% lead content

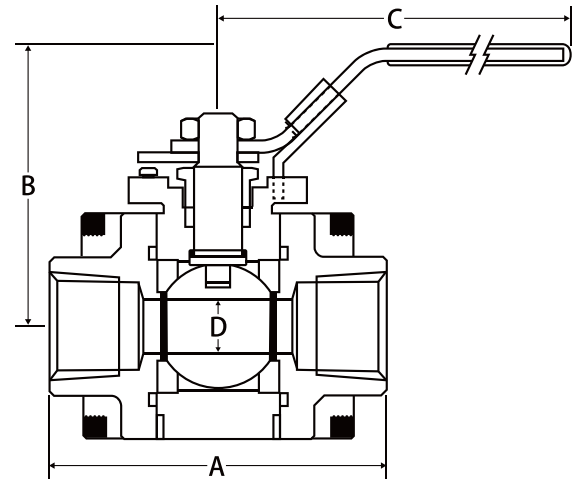

VALVE SEAT RATINGS

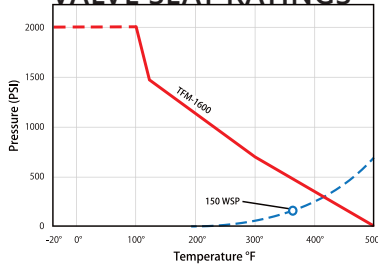

PART NUMBER	SIZE	A	B	C	D
601-603	1/2"	2.72	2.47	4.15	0.43
601-604	3/4"	2.94	2.70	4.15	0.55
601-605	1"	3.50	3.19	5.00	0.81
601-606	1-1/4"	3.90	3.64	5.98	0.98
601-607	1-1/2"	4.42	3.88	7.76	1.25
601-608	2"	5.04	4.09	7.76	1.50

*1-1/4" THROUGH 2" ARE 3 PIECE 4 BOLT PATTERN

S-SS-2001N-4B

3 PIECE 4 BOLT ENCLOSED • STANDARD PORT • SOCKET WELD • 2000 WOG



- Latch lock handle may be locked in open or closed position
- Solid ball construction
- Blow out proof stem
- 29 in-Hg vacuum rating
- Fire safe rated
- 100% leak tested
- Wetted surfaces contain less than .25% lead content

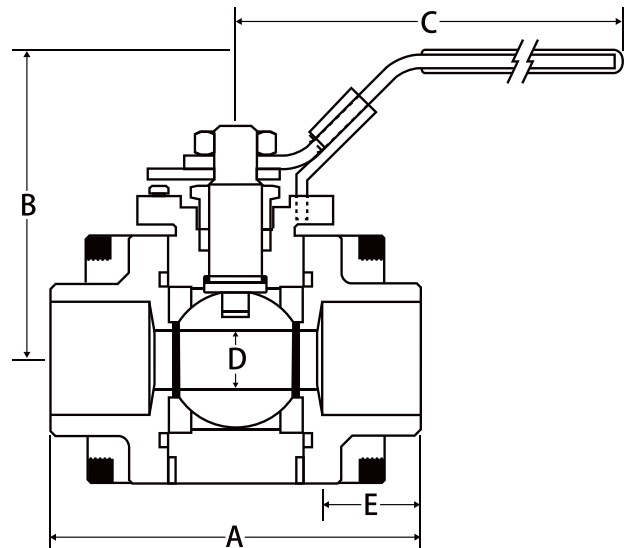

VALVE SEAT RATINGS

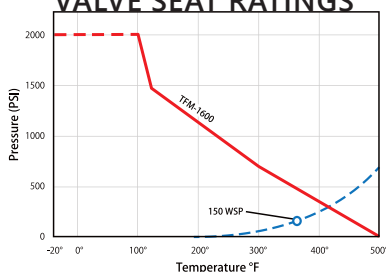

PART NUMBER	SIZE	A	B	C	D	E
601-623	1/2"	2.72	2.47	4.15	0.43	0.38
601-624	3/4"	2.94	2.70	4.15	0.55	0.50
601-625	1"	3.50	3.19	5.00	0.81	0.50
601-626	1-1/4"	3.90	3.64	5.98	0.98	0.50
601-627	1-1/2"	4.42	3.88	7.76	1.25	0.50
601-628	2"	5.04	4.09	7.76	1.50	0.62

STAINLESS STEEL BALL VALVES



T-SS-2002N-DUE 5 PIECE • FULL PORT • DOUBLE UNION END • THREADED CONNECTION • 3000 WOG



- Solid ball construction
- 5 piece construction
- Mounting pad
- Reversible handle
- Latch lock handle available
- Adjustable stem packing with blow out proof stem
- 29 in-Hg vacuum rating
- 100% leak tested
- Wetted surfaces contain less than .25% lead content

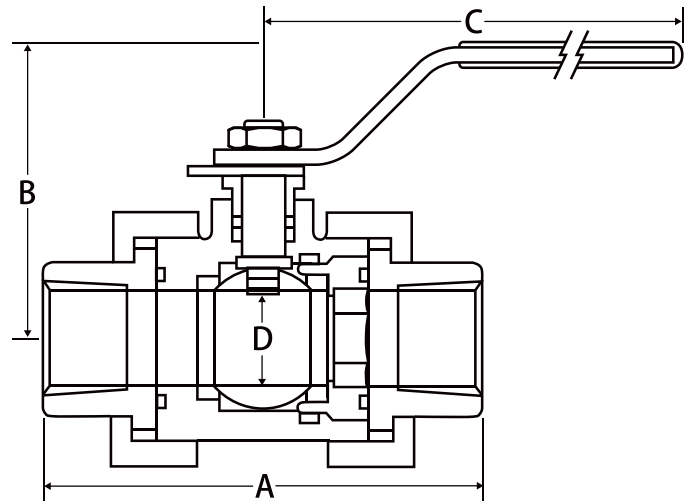

VALVE SEAT RATINGS

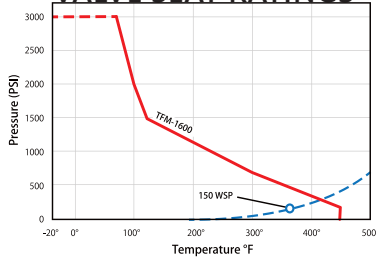

PART NUMBER	SIZE	A	B	C	D	TORQUE
100-993	1/2"	3.58	2.40	4.17	0.62	65
100-994	3/4"	3.74	2.79	6.97	0.81	100
100-995	1"	4.29	2.96	6.97	1.00	120
100-996	1-1/4"	4.61	3.38	9.84	1.25	210
100-997	1-1/2"	5.24	3.67	9.84	1.50	300
100-998	2"	5.71	4.52	12.24	1.97	400

S-SS-2002N-DUE 5 PIECE • FULL PORT • DOUBLE UNION END • SOCKET WELD • 3000 WOG



- Solid ball construction
- 5 piece construction
- Mounting pad
- Reversible handle
- Latch lock handle available
- Adjustable stem packing with blow out proof stem
- 29 in-Hg vacuum rating
- 100% leak tested
- Wetted surfaces contain less than .25% lead content

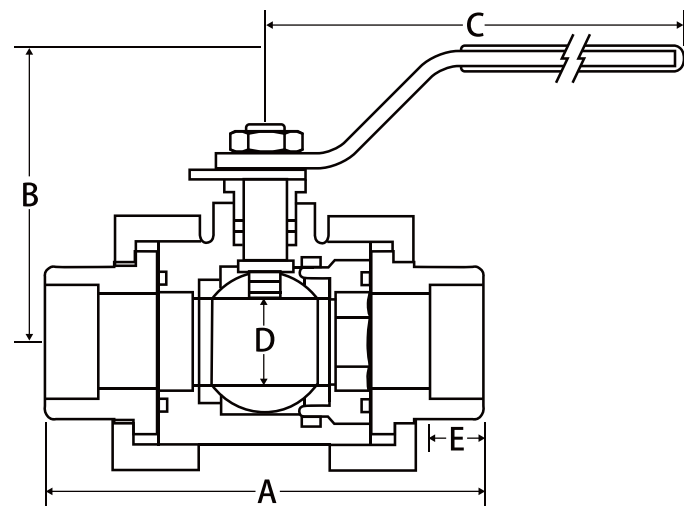

VALVE SEAT RATINGS

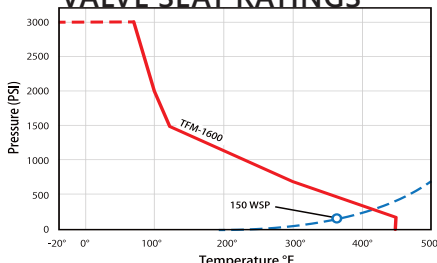

PART NUMBER	SIZE	A	B	C	D	E	TORQUE
101-983	1/2"	3.58	2.40	4.17	0.62	0.44	65
101-984	3/4"	3.74	2.79	6.97	0.81	0.56	100
101-985	1"	4.29	2.96	6.97	1.00	0.72	120
101-986	1-1/4"	4.61	3.38	9.84	1.25	0.72	210
101-987	1-1/2"	5.24	3.67	9.84	1.50	0.72	300
101-988	2"	5.71	4.52	12.24	1.97	0.84	400

T-CS-1001N-SS 2 PIECE • FULL PORT • THREADED CONNECTION • 1000 WOG STAINLESS STEEL BALL AND STEM



- Solid ball construction
- Latch lock handle may be locked in open or closed position
- 29 in-Hg vacuum rating
- 100% leak tested
- Wetted surfaces contain less than .25% lead content

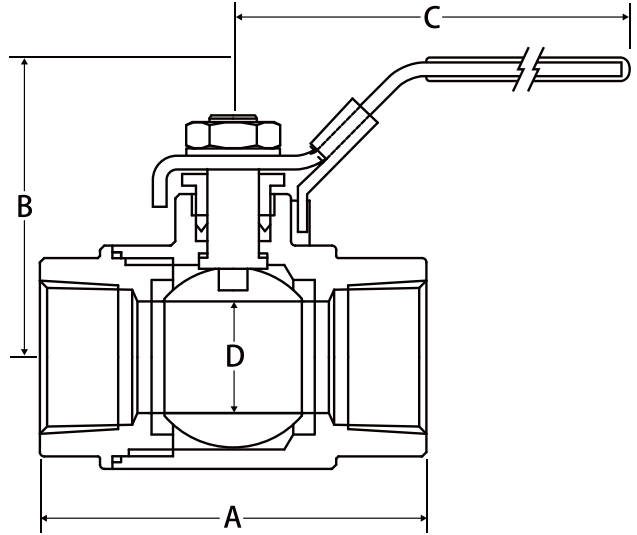
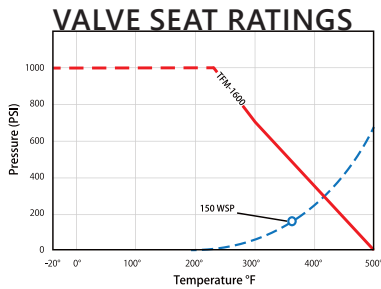

PART NUMBER	SIZE	A	B	C	D
100-971	1/4"	2.20	2.20	4.21	0.43
100-972	3/8"	2.20	2.20	4.21	0.43
100-973	1/2"	2.60	2.30	4.21	0.56
100-974	3/4"	2.99	2.79	5.73	0.81
100-975	1"	3.54	2.96	5.73	1.00
100-976	1-1/4"	3.94	3.56	7.45	1.25
100-977	1-1/2"	4.41	3.84	7.45	1.50
100-978	2"	5.00	4.24	8.08	1.97

T-CS-2000N-SS 2 PIECE • STANDARD PORT • THREADED CONNECTION • 2000 WOG STAINLESS STEEL BALL AND STEM



- Solid ball construction
- Latch lock handle may be locked in open or closed position
- 29 in-Hg vacuum rating
- 100% leak tested
- Wetted surfaces contain less than .25% lead content

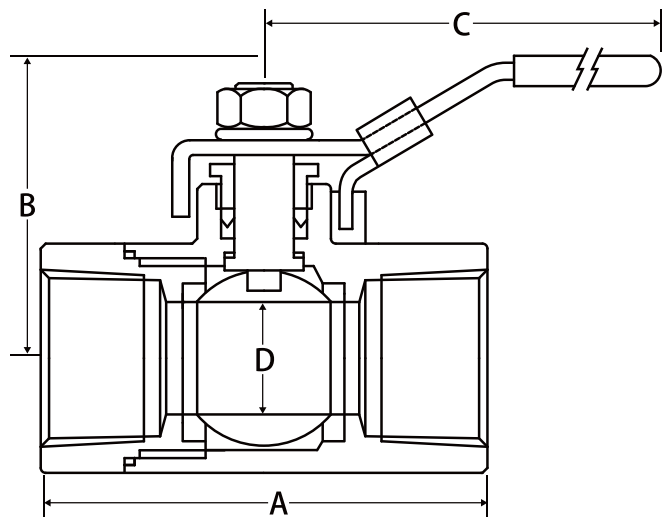
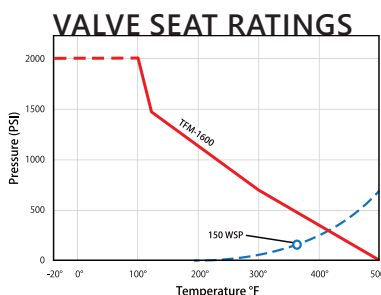

PART NUMBER	SIZE	A	B	C	D
100-951	1/4"	2.07	1.76	4.33	0.37
100-952	3/8"	2.07	1.76	4.33	0.37
100-953	1/2"	2.34	1.92	4.33	0.50
100-954	3/4"	2.80	2.40	5.83	0.69
100-955	1"	3.23	2.56	5.83	0.87
100-956	1-1/4"	3.57	2.74	7.76	1.00
100-957	1-1/2"	4.04	2.98	7.76	1.25
100-958	2"	4.63	3.17	7.76	1.50

CARBON STEEL BALL VALVES



T-CS-1000N-SS-4B



3 PIECE • 4 BOLT • SWING OUT BODY • FULL PORT • THREADED CONNECTION • 1000 WOG
STAINLESS STEEL BALL AND STEM

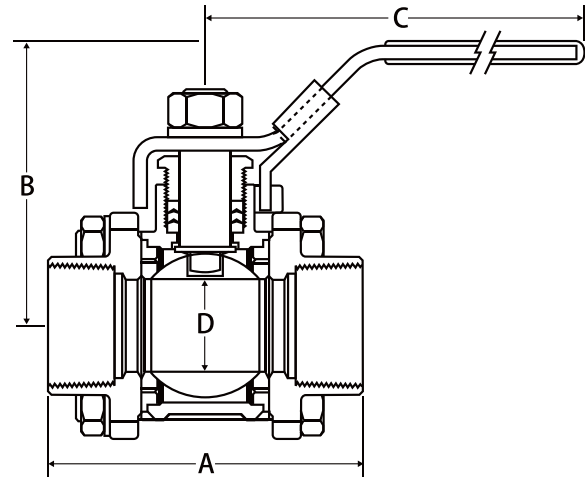

- Latch lock handle, may be locked in open or closed positions
- 29 in-Hg vacuum rating
- Repair parts available
- 100% leak tested
- Wetted surfaces contain less than .25% lead content

VALVE SEAT RATINGS

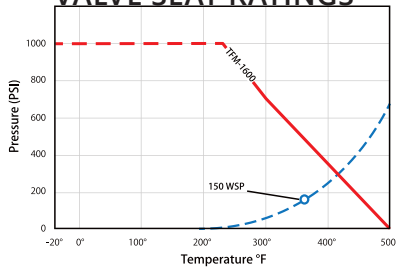

PART NUMBER	SIZE	A	B	C	D	TORQUE
500-403	1/2"	2.76	2.38	4.30	0.56	80
500-404	3/4"	3.03	2.87	5.81	0.81	150
500-405	1"	3.63	2.95	5.81	1.00	250
500-406	1-1/4"	4.14	3.66	7.44	1.25	320
500-407	1-1/2"	4.73	3.94	7.44	1.50	400

S-CS-1000N-SS-4B



3 PIECE • 4 BOLT • SWING OUT BODY • FULL PORT • SOCKET WELD • 1000 WOG
STAINLESS STEEL BALL AND STEM

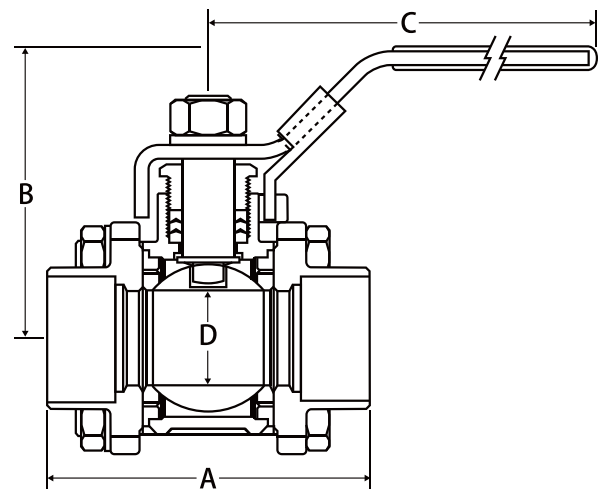

- Latch lock handle, may be locked in open or closed positions
- 29 in-Hg vacuum rating
- Repair parts available
- 100% leak tested
- Wetted surfaces contain less than .25% lead content

VALVE SEAT RATINGS

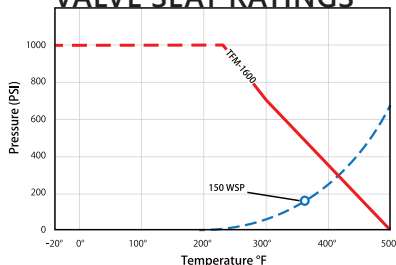

PART NUMBER	SIZE	A	B	C	D	TORQUE
500-503	1/2"	2.76	2.38	4.30	0.56	80
500-504	3/4"	3.03	2.87	5.81	0.81	150
500-505	1"	3.63	2.95	5.81	1.00	250
500-506	1-1/4"	4.14	3.66	7.44	1.25	320
500-507	1-1/2"	4.73	3.94	7.44	1.50	400
500-508	2"	5.43	4.25	7.81	1.97	480

T-CS-2002N-SS-DUE



5 PIECE • FULL PORT • DOUBLE UNION END • THREADED CONNECTION • 3000 WOG
WITH STAINLESS STEEL BALL AND STEM



- Solid ball construction
- 5 piece construction
- Mounting pad
- Reversible handle
- Latch lock handle available
- Adjustable stem packing with blow out proof stem
- 29 in-Hg vacuum rating
- 100% leak tested
- Wetted surfaces contain less than .25% lead content

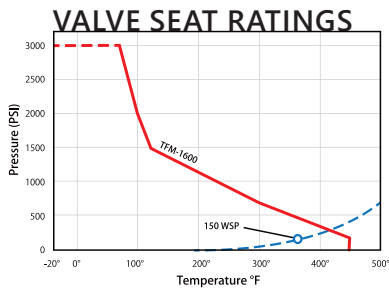
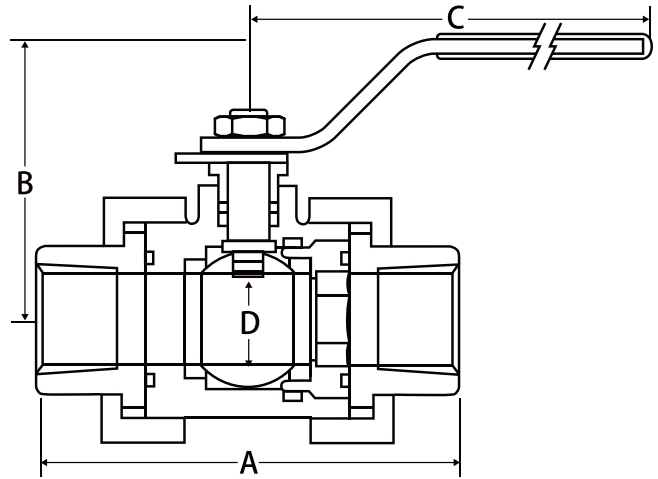

PART NUMBER	SIZE	A	B	C	D	TORQUE
100-991	1/4"	3.58	2.40	4.17	0.44	35
100-992	3/8"	3.58	2.40	4.17	0.44	35
100-993	1/2"	3.58	2.40	4.17	0.62	65
100-994	3/4"	3.74	2.79	6.97	0.81	100
100-995	1"	4.29	2.96	6.97	1.00	120
100-996	1-1/4"	4.61	3.38	9.84	1.25	210
100-997	1-1/2"	5.24	3.67	9.84	1.50	300
100-998	2"	5.71	4.52	12.24	1.97	400

S-CS-2002N-SS-DUE

5 PIECE • FULL PORT • DOUBLE UNION END • SOCKET WELD • 3000 WOG
STAINLESS STEEL BALL AND STEM



- Solid ball construction
- 5 piece construction
- Mounting pad
- Reversible handle
- Latch lock handle available
- Adjustable stem packing with blow out proof stem
- 29 in-Hg vacuum rating
- 100% leak tested
- Wetted surfaces contain less than .25% lead content

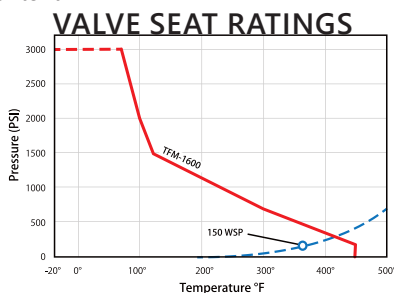
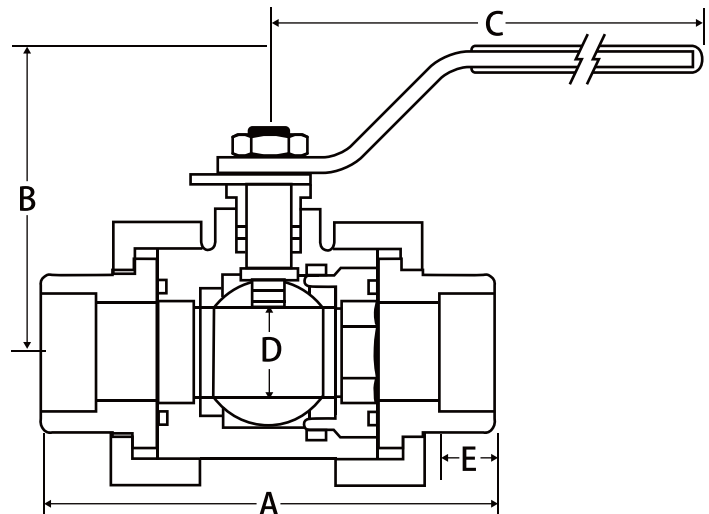

PART NUMBER	SIZE	A	B	C	D	E	TORQUE
101-991	1/4"	3.58	2.40	4.17	0.44	0.41	35
101-992	3/8"	3.58	2.40	4.17	0.44	0.41	35
101-993	1/2"	3.58	2.40	4.17	0.62	0.44	65
101-994	3/4"	3.74	2.79	6.97	0.81	0.56	100
101-995	1"	4.29	2.96	6.97	1.00	0.72	120
101-996	1-1/4"	4.61	3.38	9.84	1.25	0.72	210
101-997	1-1/2"	5.24	3.67	9.84	1.50	0.72	300
101-998	2"	5.71	4.52	12.24	1.97	0.84	400

CARBON STEEL BALL VALVES



T-CS-2001N-SS-4B



3 PIECE 4 BOLT ENCLOSED • STANDARD PORT • THREADED CONNECTION • 2000 WOG
STAINLESS STEEL BALL AND STEM



- Latch lock may be locked in open or closed position
- Solid ball construction
- Blow out proof stem
- 29 in-Hg vacuum rating
- Fire safe rated
- 100% leak tested
- Wetted surfaces contain less than .25% lead content

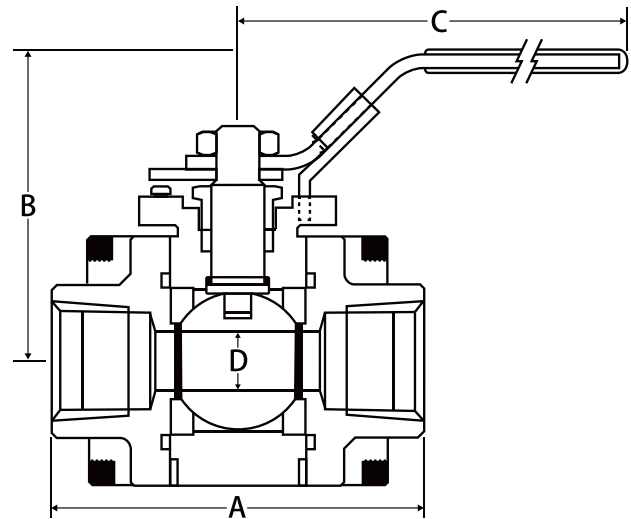

VALVE SEAT RATINGS

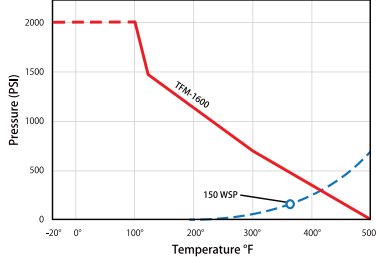

PART NUMBER	SIZE	A	B	C	D	TORQUE
601-613	1/2"	2.72	2.47	4.15	0.43	85
601-614	3/4"	2.94	2.70	4.15	0.55	150
601-615	1"	3.50	3.19	5.00	0.81	180
601-616	1-1/4"	3.90	3.64	5.98	0.98	210
601-617	1-1/2"	4.42	3.88	7.76	1.25	320
601-618	2"	5.04	4.09	7.76	1.50	440

S-CS-2001N-SS-4B

3 PIECE 4 BOLT ENCLOSED • STANDARD PORT • SOCKET WELD • 2000 WOG
STAINLESS STEEL BALL AND STEM



- Latch lock may be locked in open or closed position
- Reversible handle for multiple applications
- Solid ball construction
- Blow out proof stem
- 29 in-Hg vacuum rating
- Fire safe rated
- 100% leak tested
- Wetted surfaces contain less than .25% lead content

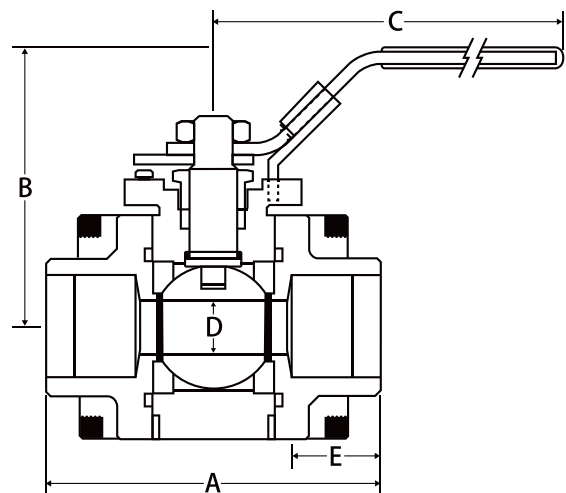

VALVE SEAT RATINGS

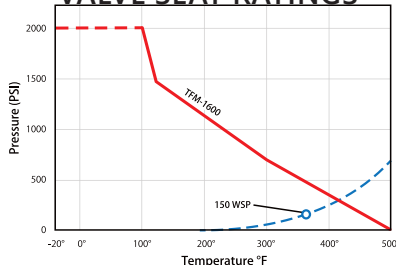

PART NUMBER	SIZE	A	B	C	D	E	TORQUE
601-633	1/2"	2.72	2.47	4.15	0.43	0.38	85
601-634	3/4"	2.94	2.70	4.15	0.55	0.50	150
601-635	1"	3.50	3.19	5.00	0.81	0.50	180
601-636	1-1/4"	3.90	3.64	5.98	0.98	0.50	210
601-637	1-1/2"	4.42	3.88	7.76	1.25	0.50	320
601-638	2"	5.04	4.09	7.76	1.50	0.62	440

T-CS-4000

FULL PORT • THREADED CONNECTION • 7250 WOG

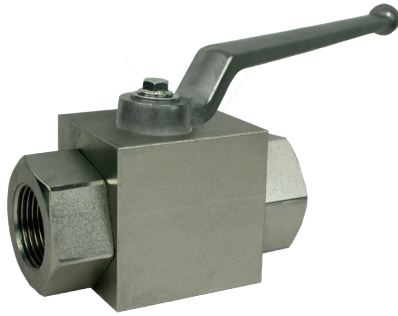

1/4" - 1/2"



3/4" - 2"

Body pressure ratings:

- 7250 PSI for 1/4" to 1/2"
- 4550 PSI for 3/4" to 2"
- Temperature rating: 14°F to 176°F
- Safety factor: 2 to 1
- Delrin ball seats
- Viton stem seal
- NPT female thread to ANSI B1.20.1
- Lockable handle option (1/4" - 1")
- Sizes 1/4" to 1" one block body design
- 1-1/4" to 2" are rounded body design
- 100% leak tested
- Wetted surfaces contain less than .25% lead content

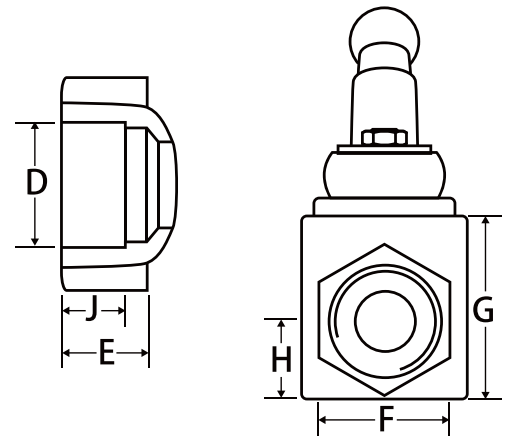
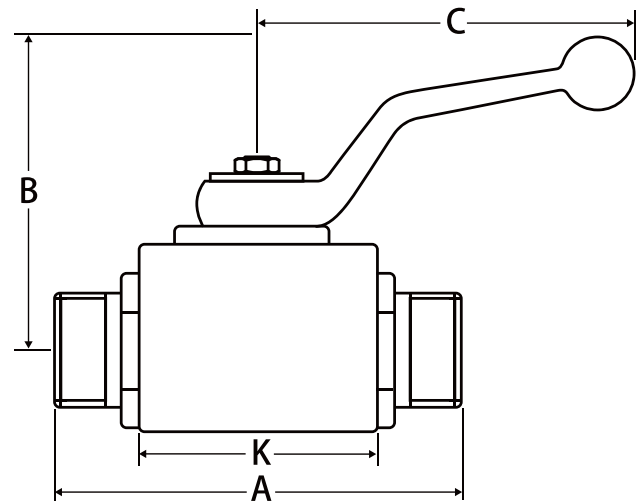

VALVE SEAT RATINGS

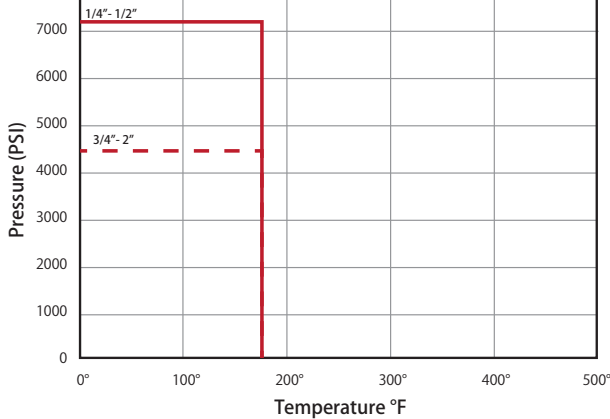

PART NUMBER	SIZE	A	B	C	D	E	F	G	H	J	K
100-941	1/4"	2.72	2.17	2.99	0.79	0.75	0.28	0.98	0.39	0.39	1.42
100-942	3/8"	2.87	2.68	3.94	1.18	0.94	0.31	1.38	0.57	0.41	1.77
100-943	1/2"	3.23	3.62	4.41	1.38	1.18	0.39	1.57	0.67	0.54	2.01
100-944	3/4"	3.66	4.45	7.36	1.77	1.61	0.55	2.17	0.94	0.55	2.36
100-945	1"	4.45	4.65	7.36	2.17	1.97	0.55	2.36	1.02	0.66	2.76
100-946	1-1/4"	4.33	4.11	9.45	2.87	2.36	0.67	3.15	1.44	0.68	2.76
100-947	1-1/2"	4.49	4.51	9.45	3.35	2.76	0.67	3.54	1.67	0.68	2.95
100-948	2"	5.12	5.20	12.60	3.90	3.35	0.67	4.09	1.95	0.70	3.50

THREAD SEALANT



COMPARISON CHART



	WOG PLUS	HEAVYWEIGHT	GREEN STUFF	WHITE STUFF	COPPER ANTI-SEIZE	NICKEL ANTI-SEIZE
JC WHITLAM	STEEL-UNYTE	SELECT-UNYTE	T-U TYPE 555	SELECT-UNYTE	TALON COPPER	TALON NICKEL
BLUE MONSTER	-	BLUE MONSTER PIRE PIPE THREAD SEALANT	BLUE MONSTER THREAD SEALANT	BLUE MONSTER PIRE PIPE THREAD SEALANT	BLUE MONSTER COPPER ANTI-SEIZE LUBRICANT	BLUE MONSTER NICKEL ANTI-SEIZE
RECTOR-SEAL	TRU-BLU	T+2	#5, #5 SPECIAL, #5 SUB-ZERO	T+2	COPPER-RICH	NICKEL-RICH
FEDERAL PROCESS	GASOLIA HARD SET	GASOILA SOFT-SET THREAD SEALANT PTFE	GASOILA-NT	GASOILA SOFT-SET THREAD SEALANT PTFE	-	GASOLIA THRED GARD
HARVEY	-	TFE PASTE	YELLOW SEALANT	TFE PASTE	-	-
HERCULES	HERCULES GRRIP	REAL-TUFF	-	REAL-TUFF	-	-
OATEY	-	GREAT WHITE	OATEY GREAT BLUE	GREAT WHITE	-	-
IPS	-	WHITE SEAL	GREEN STUFF	WHITE SEAL	-	-

USES CHART

ACETYLENE	1 drop	FREON (ALL)	5 drops	NATURAL GAS	5 drops
ACIDS, DILUTED	5 drops	GASOLINE*	4 drops	NITROGEN, GASEOUS	5 drops
AIR, COMPRESSED GASEOUS	5 drops	GASOHOL	0 drops	OXYGEN	0 drops
ALKALIS DILUTED	5 drops	GLYCOL	3 drops	PETROLEUM SOLVENTS	4 drops
AMMONIA	5 drops	HEATING OILS	4 drops	PROPANE	4 drops
ALIPHATIC SOLVENTS	4 drops	HELIUM GASEOUS	4 drops	REFRIGERATION GASES	5 drops
BRINE	5 drops	HYDRAULIC OILS	4 drops	SOAP, LIQUID	5 drops
BUTANE	4 drops	HYDROGEN	3 drops	STEAM LINES	5 drops
CARBON DIOXIDE	5 drops	INERT GASES, GASEOUS	5 drops	SUGAR, LIQUID	5 drops
CASTOR OILS	4 drops	JET FUEL (JP 3,4,5)	4 drops	VEGETABLE OILS	4 drops
CHLORINATED WATER	4 drops	KEROSENE	4 drops	WATER (HOT OR COLD)	5 drops
CORROSIVES	3 drops	LACQUER	4 drops	XYLOL	3 drops
COAL TAR NAPHTHA	3 drops	LIQUEFIED PETROLEUM GASES	4 drops		
CUTTING OILS	4 drops	MANUFACTURED GASES	4 drops		
DIESEL FUEL OIL	4 drops	MINERAL OILS	4 drops		
FATTY ACIDS (LIQUIDS)	3 drops	NAPHTHA	3 drops		

*CONTACT JOMAR FOR COMPATIBLE BLENDS

The information contained in this bulletin is correct to the best of our knowledge. The recommendations or suggestions herein are made without guarantee or representation as to result, since the conditions of use are beyond our control. We suggest that you evaluate the recommendations contained in this bulletin. No statement is to be construed as violating any copyright or patent. They are intended only as a source of information.

FL-SS-100-150



2 PIECE • FULL PORT • STAINLESS STEEL • FLANGED CONNECTION • CLASS 150



- Wrench operator
- Fire safe stem and body graphite seals
- Air tested seat leakage: 85 PSI
- Hydraulic tested body: 427 PSI
- Locking device comes standard
- 100% leak tested
- Wetted surfaces contain less than .25% lead content

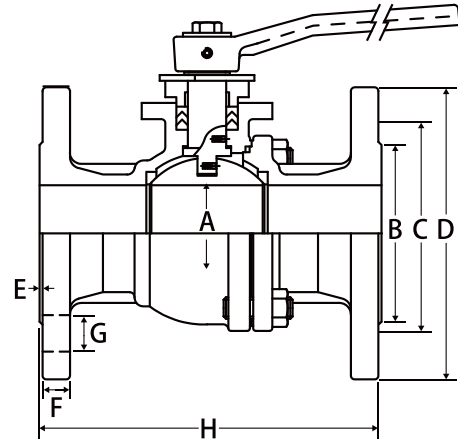

PART NUMBER	SIZE	A	B	C	D	E	F	G	H	BOLTS	TORQUE
600-103	1/2"	0.63	1.38	2.38	3.50	0.06	0.44	0.63	4.25	4	48
600-104	3/4"	0.79	1.69	2.76	3.86	0.06	0.44	0.63	4.61	4	90
600-105	1"	0.98	2.01	3.13	4.25	0.06	0.44	0.63	5.00	4	148
600-107	1-1/2"	1.50	2.87	3.88	5.00	0.06	0.56	0.63	6.50	4	270
600-108	2"	1.97	3.62	4.74	5.98	0.06	0.63	0.75	7.01	4	395
600-109	2-1/2"	2.56	4.13	5.49	7.01	0.06	0.69	0.75	7.48	4	609
600-110	3"	3.15	5.00	6.00	7.48	0.06	0.75	0.75	7.99	4	913
600-111	4"	3.94	6.18	7.50	9.02	0.06	0.94	0.75	9.02	8	1443
600-112	6"	5.98	8.50	9.51	10.98	0.06	1.00	0.87	15.51	8	4870
600-113*	8"	7.99	10.63	11.75	13.50	0.06	1.12	0.87	17.99	8	8522
600-114*	10"	9.84	12.76	14.25	15.98	0.06	1.19	0.98	20.98	12	-
600-115*	12"	11.81	12.52	17.01	19.02	0.06	1.25	0.98	24.02	12	-

* 8-12" SPECIAL ORDER

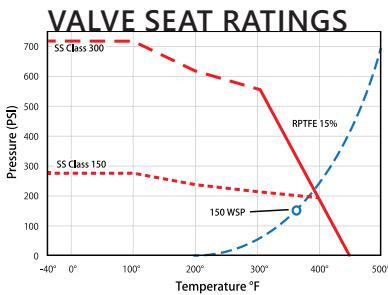

FL-SS-100-300



2 PIECE • FULL PORT • STAINLESS STEEL • FLANGED CONNECTION • CLASS 300

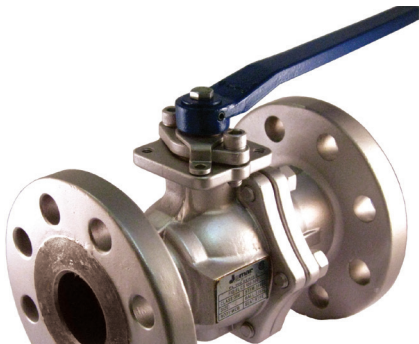

- Wrench operator
- Fire safe stem and body graphite seals
- Air tested seat leakage: 85 PSI
- Hydraulic tested body: 1124 PSI
- Locking device comes standard
- 100% leak tested
- Wetted surfaces contain less than .25% lead content

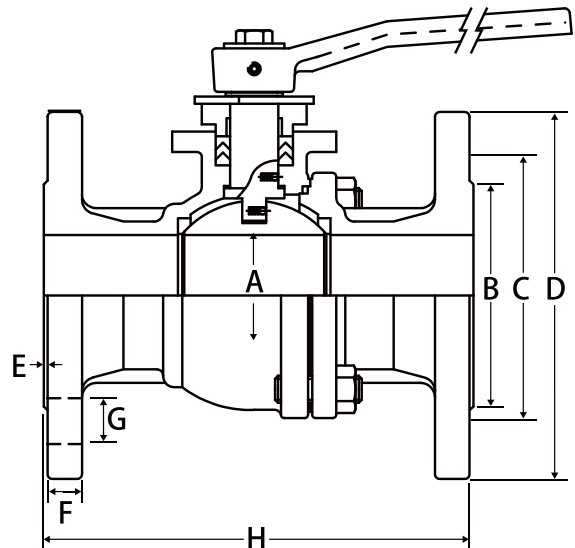

PART NUMBER	SIZE	A	B	C	D	E	F	G	H	BOLTS	TORQUE
600-128	2"	1.97	3.62	5.00	6.50	0.06	0.88	0.75	8.50	8	1068
600-130	3"	3.15	5.00	6.62	8.27	0.06	1.17	0.88	11.10	8	1752
600-131	4"	3.94	6.19	7.88	10.00	0.06	1.25	0.88	12.00	8	3216
600-132	6"	5.90	8.51	10.64	12.53	0.06	1.44	0.88	15.88	12	6900
600-133*	8"	7.88	10.64	13.00	15.01	0.06	1.62	1.00	19.75	12	16620

* 8" SPECIAL ORDER

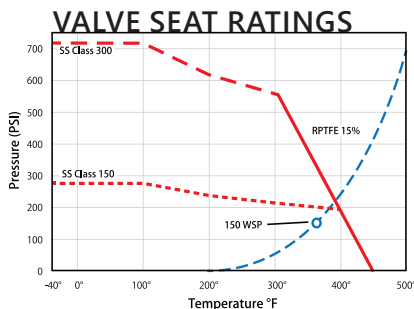

FLANGED BALL VALVES



FL-CS-100-150



2 PIECE • FULL PORT • CARBON STEEL • FLANGED CONNECTIONS • CLASS 150
STAINLESS STEEL BALL AND STEM



- Wrench operator
- Fire safe stem and body graphite seals
- Air tested seat leakage: 85 PSI
- Hydraulic tested body: 427 PSI
- Locking device comes standard
- 100% leak tested
- Wetted surfaces contain less than .25% lead content

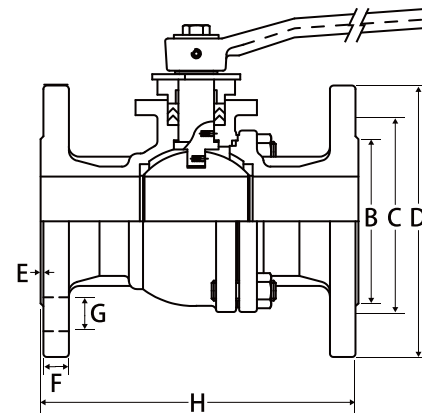

PART NUMBER	SIZE	A	B	C	D	E	F	G	H	BOLTS	TORQUE
600-203	1/2"	0.63	1.38	2.38	3.50	0.06	0.44	0.63	4.25	4	48
600-204	3/4"	0.79	1.69	2.76	3.86	0.06	0.44	0.63	4.61	4	90
600-205	1"	0.98	2.01	3.13	4.25	0.06	0.44	0.63	5.00	4	148
600-207	1-1/2"	1.50	2.87	3.88	5.00	0.06	0.56	0.63	6.50	4	270
600-208	2"	1.97	3.62	4.74	5.98	0.06	0.63	0.75	7.01	4	395
600-209	2-1/2"	2.56	4.13	5.49	7.01	0.06	0.69	0.75	7.48	4	609
600-210	3"	3.15	5.00	6.00	7.48	0.06	0.75	0.75	7.99	4	913
600-211	4"	3.94	6.18	7.50	9.02	0.06	0.94	0.75	9.02	8	1443
600-212	6"	5.98	8.50	9.51	10.98	0.06	1.00	0.87	15.51	8	4870
600-213*	8"	7.99	10.63	11.75	13.50	0.06	1.12	0.87	17.99	8	8522
600-214*	10"	9.84	12.76	14.25	15.98	0.06	1.19	0.98	20.98	12	-
600-215*	12"	11.81	12.52	17.01	19.02	0.06	1.25	0.98	24.02	12	-

*8-12" SPECIAL ORDER

VALVE SEAT RATINGS

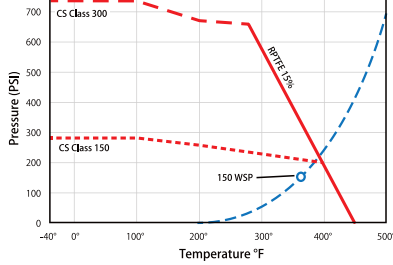

FL-CS-100-300



3 PIECE 4 BOLT ENCLOSED • STANDARD PORT • SOCKET WELD • 2000 WOG
STAINLESS STEEL BALL AND STEM



- Wrench operator
- Fire safe stem and body graphite seals
- Air tested seat leakage: 85 PSI
- Hydraulic tested body: 1124 PSI
- Locking device comes standard
- 100% leak tested
- Wetted surfaces contain less than .25% lead content

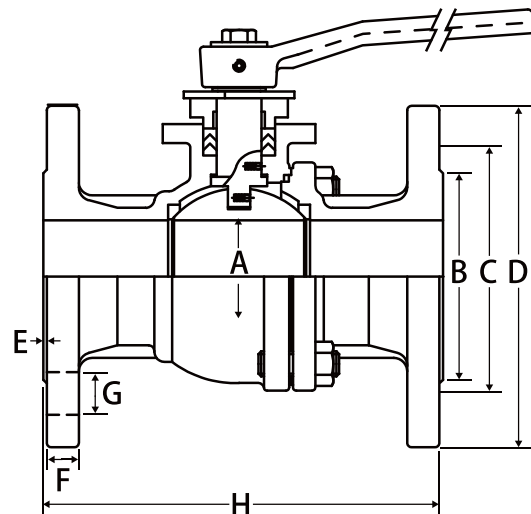

PART NUMBER	SIZE	A	B	C	D	E	F	G	H	BOLTS	TORQUE
600-228	2"	1.97	3.62	5.00	6.50	0.06	0.88	0.75	8.50	8	1068
600-230	3"	3.15	5.00	6.62	8.27	0.06	1.17	0.88	11.10	8	1752
600-231	4"	3.94	6.19	7.88	10.00	0.06	1.25	0.88	12.00	8	3216
600-232	6"	5.90	8.51	10.64	12.53	0.06	1.44	0.88	15.88	12	6900
600-233*	8"	7.88	10.64	13.00	15.01	0.06	1.62	1.00	19.75	12	16620

*8" SPECIAL ORDER

VALVE SEAT RATINGS

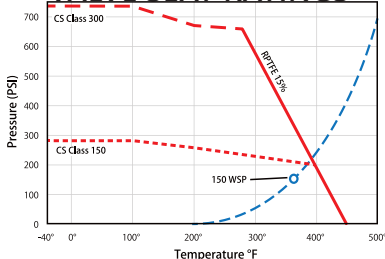

AE SERIES- ELECTRICAL ACTUATORS DOUBLE ACTING • NEMA 4X • MANUAL OVERRIDE

Hard anodized aluminum housing with external powder coating for severe duty applications.



AE-1400



AE-350



AE-880



AE-180



AE-700

- 90° operation
- Enclosure: IP67 (Nema 4, 4X)
- ISO 5211 mounting
- Worm gearing, no brake required
- Manual override standard
- Squirrel cage induction motor
- Duty Cycle: 50%
- 4 Limit switches (2 for AE-180)
- 5W internal heater (AE-880 and larger)
- Terminal block for ease in wiring
- Position indicator
- Adjustable travel stops standard
- Torque switches for overload protection (except AE-180)
- Cable entries: M20 x 1.5 for AE-350 and AE-700, 3/4" NPT for all others
- Temperature range:
AE-180: -22°F to 140°F
AE-700 - AE-9700: -4°F to 158°F

MODEL	CSA	TORQUE IN - LB	SPEED 90 / 120VAC	OUTPUT SQ. ISO MOUNTING	PWR. RATING WATTAGE	INSULATION CLASS	WEIGHT IN - LB	LIMIT SWITCHES	CABLE ENTRY	INTERNAL HTR.	TERMINAL WIRING BLOCK	TORQUE OL PROTECTION
AE-180		180	15	.43/F03/F04/F05	6	E	2.64	2	PIGTAIL	NO	NO	N/A
AE-350		350	12	.55/F03/F05/F07	—	E	6.60	4	M20 X 1.5	YES	YES	N/A
AE-700		700	14	.67/F05/07	15	E	7.70	4	M20 X 1.5	YES	YES	N/A
AE-880		880	18	.67/F07	15	F	15.40	4	3/4 NPT	YES	YES	N/A
AE-1400		1400	22	.87/F07/10	40	F	33	4	3/4 NPT	YES	YES	YES
AE-2100		2125	22	.87/F07/10	40	F	33	4	3/4 NPT	YES	YES	YES
AE-3100		3098	26	1.06/F10/12	40	F	44	4	3/4 NPT	YES	YES	YES
AE-4400		4425	26	1.06/F10/12/14	90	F	44	4	3/4 NPT	YES	YES	YES
AE-7000		7080	32	1.42/F12/14	180	F	55	4	3/4 NPT	YES	YES	YES
AE-9700		9735	32	1.54/F14	180	F	55	4	3/4 NPT	YES	YES	YES

24 VDC & 24 VAC ELECTRIC ACTUATOR • DOUBLE ACTING NEMA 4X • MANUAL OVERRIDE

Hard anodized aluminum housing with external powder coating for severe duty applications.



AE-1400 - AE-9700



AE-700



AE-800

- Temperature range:
-4°F to 158°F - AE-350 and larger
-22°F to 140°F - AE-180 90° operation
- Enclosure: IP67 (Nema 4, 4X)
- ISO 5211 mounting
- Worm gearing, no brake required
- Manual override standard
- Torque switches for overload protection (except for AE-180)
- Squirrel cage induction motor
- Duty Cycle: 50%
- 4 Limit switches (2 for AE-180)
- Cable entries: 3/4" NPT / M20 x 1.5
- 5W internal heater (AE-350 and larger)
- Terminal block for ease in wiring
- Position indicator
- Adjustable travel stops standard

PART NUMBER	TORQUE	CYCLE TIME
AE-180-24VDC	180	12
AE-350-24VDC	350	12
AE-700-24VDC	700	12
AE-880-24VDC	880	18
AE-1400-24VDC	1400	33
AE-2100-24VDC	2125	33
AE-3100-24VDC	3098	37
AE-4400-24VDC	4425	34
AE-7000-24VDC	7080	39
AE-9700-24VDC	9735	39
AE-180-24VAC	180	12
AE-700-24VAC	700	14
AE-880-24VAC	880	26
AE-1400-24VAC	1400	26
AE-2100-24VAC	2125	26
AE-3100-24VAC	3098	31
AE-4400-24VAC	4425	31
AE-7000-24VAC	7080	39
AE-9700-24VAC	9735	39

JOMAR DOMESTIC ELECTRIC ACTUATORS SPECIAL ORDER ONLY

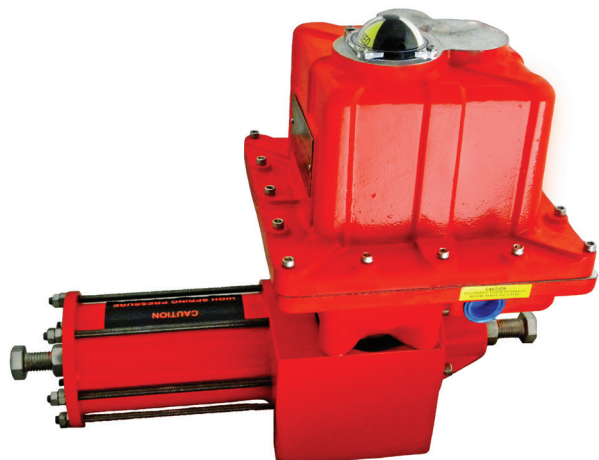

In addition to the AE Series, Jomar Valve also offers a wide range of specialty electric actuators tailored for your specific application. Jomar Valve offers you the following Made in America products:

- NEMA 4, 4x & 7 Enclosures
- Spring Return Electric Actuators
- 24, 115, 230, & 480 AC/ DC Voltages
- 100lbs-14000lbs Torque ranges
- Failsafe Battery Backup
- Other Actuator Accessories
- Jomar Valve can accommodate any application.

JV SERIES - PNEUMATIC ACTUATORS SPRING RETURN AND DOUBLE ACTING ROTARY

The Jomar JV Series rotary pneumatic actuators are designed for use with quarter-turn ball, butterfly and plug valves as well as damper applications. The JV Series is designed for high-cycle applications and can be utilized in hazardous and corrosive environments.



Actuator Shown with ASV-120 Solenoid and Speed Control Mufflers

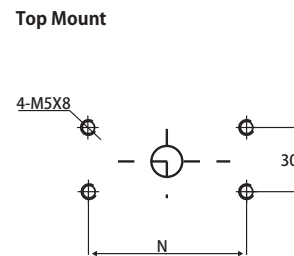
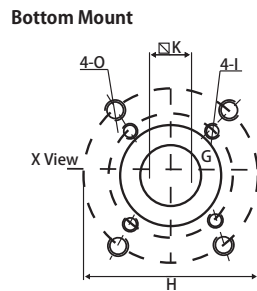
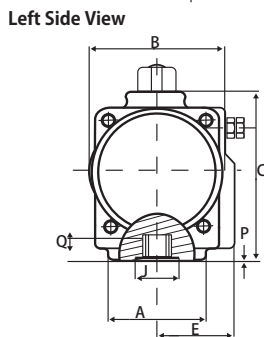
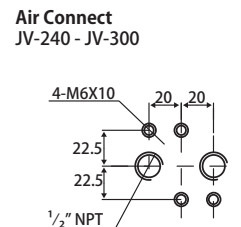
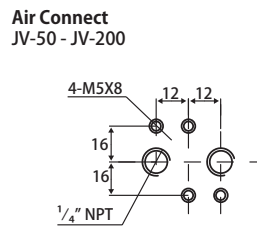
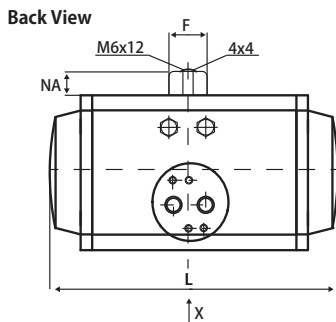

PART NUMBER	DIMENSIONS																		AIR CONNECTION
	A	B	C	E	NA	F	G ISO	G DIA DIM	H ISO	H DIA DIM	I	J	K	L	N	O	P	Q	
JV-50	2.05	2.28	2.76	1.61	0.79	1.57	F03	1.42	F05	1.97	M5X8	0.98	0.43	6.30	3.15	M6X10	0.04	0.47	1/4" NPT
JV-60	2.52	2.91	3.50	1.89	0.79	1.57	F05	1.97	F07	2.76	M6X10	1.10	0.55	7.56	3.15	M8X13	0.04	0.63	1/4" NPT
JV-70	2.68	3.35	3.94	2.05	0.79	1.57	F05	1.97	F07	2.76	M6X10	1.26	0.55	8.58	3.15	M8X13	0.04	0.63	1/4" NPT
JV-80	2.68	3.78	4.45	2.20	0.79	1.57	F05	1.97	F07	2.76	M6X10	1.42	0.67	9.37	3.15	M8X13	0.04	0.75	1/4" NPT
JV-90	3.74	4.21	4.84	2.56	0.79	1.57	F07	2.76	F10	4.02	M8X13	1.57	0.67	10.75	3.15	M10X16	0.04	0.75	1/4" NPT
JV-100	3.78	4.72	5.35	2.76	0.79	1.57	F07	2.76	F10	4.02	M8X13	1.57	0.87	10.79	3.15	M10X16	0.04	0.75	1/4" NPT
JV-120	3.78	5.43	6.34	3.15	0.79	2.28	F07	2.76	F10	4.02	M8X13	2.09	0.87	13.19	3.15	M10X16	0.06	0.94	1/4" NPT
JV-140	4.65	6.06	7.01	3.54	0.79	2.28	F10	4.02	F12	4.92	M10X16	2.09	1.06	14.57	5.12	M12X20	0.06	1.14	1/4" NPT
JV-160	4.65	6.93	7.87	4.06	0.79	2.28	F10	4.02	F12	4.92	M10X16	2.60	1.06	16.85	5.12	M12X20	0.06	1.14	1/4" NPT
JV-190	5.35	8.23	9.13	4.41	0.79	2.28	F10	4.02	F14	5.51	M10X16	3.07	1.42	19.21	5.12	M16X25	0.06	1.50	1/4" NPT
JV-200	5.51	9.09	10.04	4.80	1.18	3.15	-	-	F14	5.51	-	3.46	1.42	21.65	5.12	M16X25	0.06	1.50	1/4" NPT
JV-240	6.50	11.02	11.97	6.10	1.18	3.15	-	-	F16	6.50	-	3.94	1.81	23.54	5.12	M20X28	0.06	1.89	1/2" NPT
JV-270	6.50	11.97	12.99	6.57	1.18	3.15	-	-	F16	6.50	-	4.33	1.81	26.46	5.12	M20X28	0.08	1.89	1/2" NPT
JV-300	6.85	12.83	13.94	6.89	1.18	3.15	-	-	F16	6.50	-	4.92	1.81	30.87	5.12	M20X28	0.08	1.89	1/2" NPT

_ = Must specify style: D = Double Acting, S = Spring Return

AEP-100 ELECTRO-PNEUMATIC ROTARY POSITIONER

Intended for use with either spring return or double acting pneumatic actuators to provide control of the actuator rotation utilizing an electrical control signal or control system.

- Aluminum housing construction
- Visual position indicator
- For use with 1/4-turn rotary actuators



AEP-100 ELECTRO-PNEUMATIC ROTARY POSITIONER

Intended for use with either spring return or double acting pneumatic actuators to provide control of actuator rotation utilizing a 3-15 PSI control air signal.

- Aluminum housing construction
- Visual position indicator
- For use with 1/4-turn rotary actuators



FEATURE	MEASURE
ENCLOSURE	IP66
INPUT	4-20MA / 0-10 VDC
SUPPLY	20-100 PSI
IMPEDANCE	250 OHM ± 15 OHM
LINERARITY	±2% FS
OPERATING TEMPERATURE	-4°F TO 158°F
REPEATABILITY	±0.5% FS
HYSTERESIS	±1% FS
FLOW CAPACITY	80 LPM
AIR CONSUMPTION	3 LPM
WEIGHT	6.21 LB
ENCLOSURE	IP66
EXPLOSION PROOF APPROVAL	EXDII BT6
SIGNAL CONNECTIONS	1/2" CONDUIT
CONNECTIONS	1/4" AIR ; 1/8" GAUGE

FEATURE	MEASURE
INPUT	3-15 PSI
SUPPLY	20-100 PSI
LINERARITY	±2% FS
OPERATING TEMPERATURE	-4°F TO 158°F
REPEATABILITY	±0.5% FS
HYSTERESIS	±1% FS
FLOW CAPACITY	80 LPM
AIR CONSUMPTION	3 LPM
WEIGHT	3.7 LB
ENCLOSURE	IP66
CONNECTIONS	1/4" AIR ; 1/8" GAUGE

ASM-200 LIMIT SWITCH WITH DOME INDICATOR



- Die-cast aluminum, epoxy-polyester coated housing
- O-ring sealed to prevent contaminants from entering switch compartment
- Position indicator manufactured of high-impact polycarbonate; yellow = open / red = closed
- Mechanical switches (2) are of SPDT design
- Eight position terminal strip included
- Enclosure is IP 67 weatherproof design
- Stainless steel mounting bracket made to NAMUR

ASV-120 FOUR WAY SOLENOID VALVE

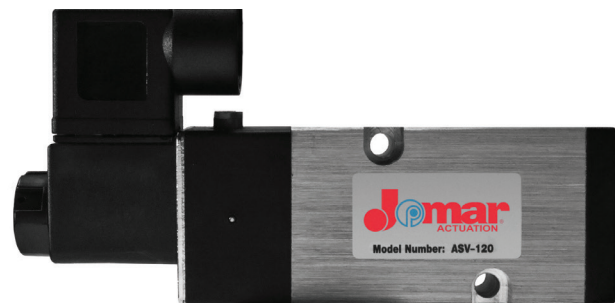

- Extruded aluminum body with NBR seal
- 120/60/1 coil with IP 67 rating
- Manual override
- 1/4" NPT Exhaust port
- 1/2" NPT conduit connection
- Operating Temp: -40°F to 140°F
- Operating Pressure: 20 to 120 PSI
- Options: 24 VAC, 240 VAC, 24 VDC, 120 VAC explosion proof

T/S-703

TRU-UNION PVC • SCHEDULE 80 • THREADED AND SOLVENT CONNECTIONS • 150 WOG

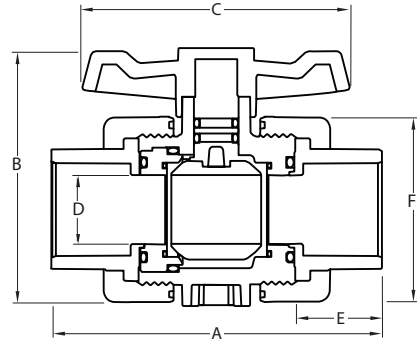

- NPS Connections
- Easy installation with hand-tightened union nuts
- Easy line breakdowns without installing additional units
- Full port design minimum flow restrictions
- Manufactured/assembled without hydrocarbon lubricants

- Mounting pads for electric or pneumatic actuation
- Includes threaded and socket ends
- Wetted surfaces contain less than .25% lead content

Pressure Rating

- Max service temperature 140°F, 150 PSI @ 73°F continuous
- Min temperature 41°F

PART NUMBER	SIZE	A	B	C	D	E	F
210-543	1/2"	3.76	2.76	2.84	0.55	0.88	1.89
210-544	3/4"	4.16	3.25	3.35	0.79	1.00	2.32
210-545	1"	4.72	3.60	3.86	0.98	1.13	2.64
210-546	1.25"	5.32	4.25	4.02	1.26	1.25	3.07
210-547	1.5"	5.96	4.82	4.53	1.58	1.38	3.66
210-548	2"	6.81	5.85	5.55	1.99	1.50	4.45
210-549	2.5"	8.27	7.32	7.09	2.48	1.75	5.59
210-550	3"	9.61	8.62	8.19	3.03	1.88	6.61
210-551	4"	12.91	11.22	10.79	4.01	2.25	8.90

T-701 PVC • SCHEDULE 80 • THREADED CONNECTION • 150 WOG

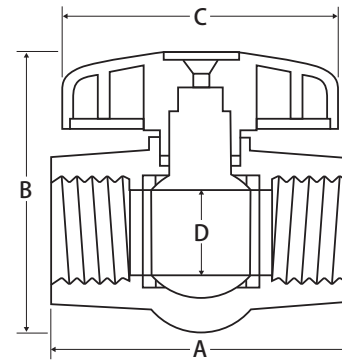

- NPS connections
- Minimal pressure drop/turbulence
- Large ports for greater flow
- Corrosion resistance PVC material
- Wetted surfaces contain less than .25% lead content

Pressure Rating

- Max service temperature 140°F, 150 PSI @ 73°F continuous
- Min temperature 41°F

PART NUMBER	SIZE	A	B	C	D
210-203	1/2"	3.27	2.52	2.76	0.55
210-204	3/4"	3.74	3.11	3.46	0.79
210-205	1"	4.17	3.74	3.94	0.98
210-206	1-1/4"	4.49	3.90	3.94	1.18
210-207	1-1/2"	5.12	4.53	4.29	1.42
210-208	2"	5.79	5.31	5.28	1.83
210-209	2-1/2"	8.03	6.30	7.01	2.28
210-210	3"	9.02	7.48	8.82	3.03
210-211	4"	11.81	9.17	10.87	3.86

S-701 PVC • SCHEDULE 80 • SOLVENT CONNECTION • 150 WOG

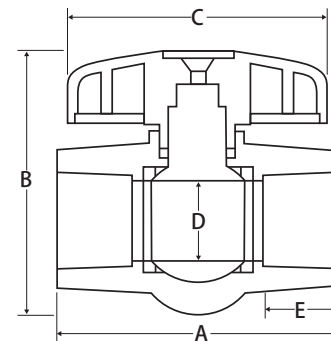

- NPS connections
- Minimal pressure drop/turbulence
- Large ports for greater flow
- Corrosion resistance PVC material
- Wetted surfaces contain less than .25% lead content

Pressure Rating

- Max service temperature 140°F, 150 PSI @ 73°F continuous
- Min temperature 41°F

PART NUMBER	SIZE	A	B	C	D	E
210-223	1/2"	3.27	2.52	2.76	0.55	0.87
210-224	3/4"	3.74	3.11	3.46	0.79	1.00
210-225	1"	4.17	3.74	3.94	0.98	1.12
210-226	1-1/4"	4.49	3.90	3.94	1.18	1.25
210-227	1-1/2"	5.12	4.53	4.29	1.42	1.38
210-228	2"	5.79	5.31	5.28	1.83	1.50
210-229	2-1/2"	8.03	6.30	7.01	2.28	1.75
210-230	3"	9.02	7.48	8.82	3.03	1.88
210-231	4"	11.81	9.17	10.87	3.86	2.25

DIELECTRIC UNION LEAD FREE BRASS FIP X GALVANIZED FIP • 250 PSI

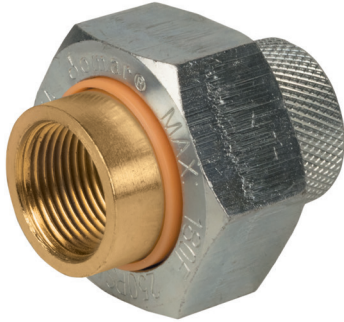

- Prevents accelerated corrosion
- -20°F to 180°F - Buna Seats
- Wetted surfaces contain less than .25% lead content

Pressure Rating

- 250 PSI

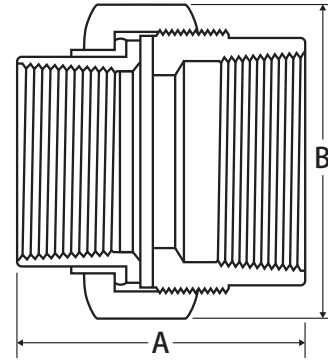

PART NUMBER	SIZE	A	B	C
701-503G	1/2" FIP X 1/2" FIP	2.14	1.61	0.72
701-504G	3/4" FIP X 3/4" FIP	2.21	1.83	0.72
701-505G	1" FIP X 1" FIP	2.54	2.58	0.85

DIELECTRIC UNION GALVANIZED FIP X FIP • 250 PSI

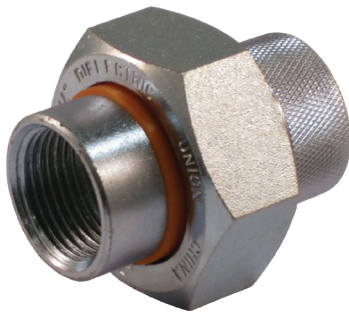

- Prevents accelerated corrosion
- -20°F to 180°F - Buna Seats

Pressure Rating

- 250 PSI

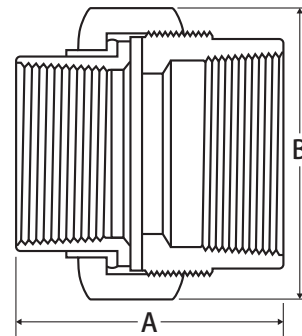

PART NUMBER	SIZE	A	B
701-413	1/2" FIP X 1/2" FIP	2.14	1.61
701-414	3/4" FIP X 3/4" FIP	2.21	1.83
701-415	1" FIP X 1" FIP	2.54	2.58
701-416	1-1/4" FIP X 1-1/4" FIP	2.73	2.96
701-417	1-1/2" FIP X 1-1/2" FIP	2.73	3.75
701-418	2" FIP X 2" FIP	3.12	4.30

DIELECTRIC UNION BLACK IRON FIP X FIP, 250 PSI

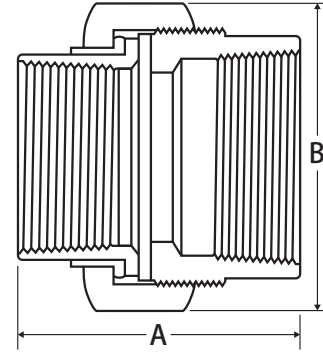

- Prevents accelerated corrosion
- For use on black pipe
- -20°F to 180°F - Buna seats standard

Pressure Rating

- 250 PSI

PART NUMBER	SIZE	A	B
701-403	1/2" FIP X 1/2" FIP	2.14	1.61
701-404	3/4" FIP X 3/4" FIP	2.21	1.83
701-405	1" FIP X 1" FIP	2.54	2.58
701-406	1-1/4" FIP X 1-1/4" FIP	2.73	2.96
701-407	1-1/2" FIP X 1-1/2" FIP	2.73	3.75
701-408	2" FIP X 2" FIP	3.12	4.30

A-101

2 PIECE • FULL PORT • THREADED CONNECTION • 600 WOG
ISO MOUNTING PAD • STAINLESS STEEL BALL AND STEM

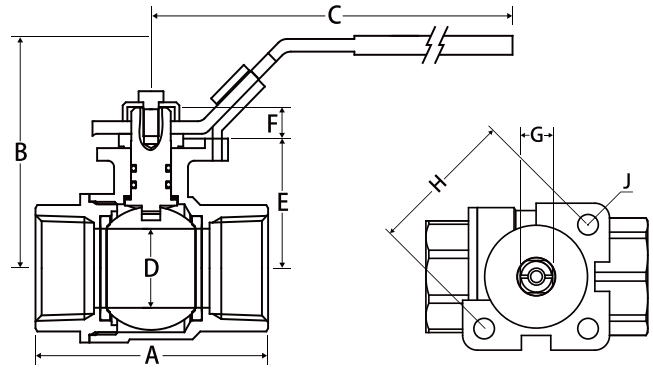

- Square valve stem for direct mounting to any ISO actuator
- Wetted surface contains less than .25% lead content
- Latch lock may be locked in open or closed position
- Dezincification resistant alloy
- ISO 5211 direct mounting pad
- Blow out proof stem
- 100% leak tested

VALVE SEAT RATINGS

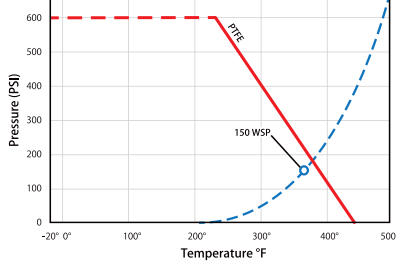

PART NUMBER	SIZE	A	B	C	D	E	F	G	H	J	ISO	TORQUE
A101-12	1/2"	2.39	2.34	4.76	0.59	1.14	0.37	0.35	1.42	0.23	F03	16
A101-34	3/4"	2.57	2.48	4.76	0.75	1.28	0.37	0.35	1.42	0.23	F03	23
A101-1	1"	2.97	2.85	6.73	0.98	1.59	0.39	0.43	1.97	0.28	F05	36
A101-114	1-1/4"	3.44	3.15	6.73	1.26	1.82	0.39	0.43	1.97	0.28	F05	73
A101-112	1-1/2"	3.88	3.64	6.73	1.57	2.32	0.43	0.43	1.97	0.28	F05	76
A101-2	2"	4.29	3.94	6.73	1.94	2.62	0.43	0.43	1.97	0.28	F05	130

T-100 DIRECT MOUNT

2 PIECE • FULL PORT • THREADED CONNECTION • 600 WOG
ISO MOUNTING PAD

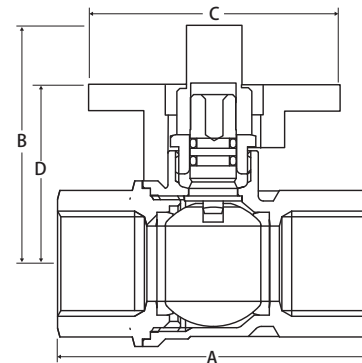
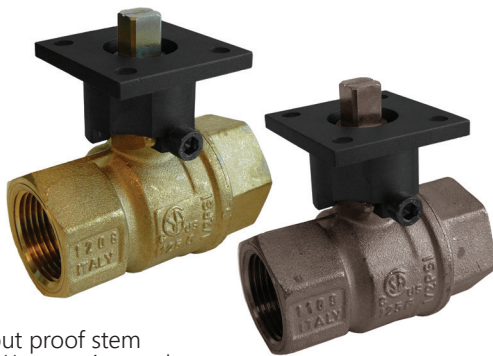

- Blow out proof stem
- ISO 5211 mounting pad
- 100% leak tested
- Fits any T-100, S-100, or JP-100

T-100SSE									
PART NUMBER	BRACKET & COUPLER	SIZE	A	B	C	D	ISO	SQ	TORQUE (IN LBS)
100-501	A1B-A1C11	1/4"	1.86	1.77	1.97	1.26	F03/F05	0.43	23
100-502	A1B-A1C11	3/8"	1.86	1.77	1.97	1.26	F03/F05	0.43	23
100-503	A1B-A1C11	1/2"	2.45	1.95	1.97	1.50	F03/F05	0.43	35
100-504	A2B-A2C11	3/4"	2.71	2.10	1.97	1.43	F03/F04/F05	0.43	62
100-505	A3B-A3C11	1"	3.30	2.63	1.97	2.12	F05	0.43	89
100-506	A3B-A3C11	1-1/4"	3.80	2.81	1.97	2.35	F05	0.43	132
100-507	A4B-A4C14	1-1/2"	4.16	2.84	2.79	2.44	F05/F07	0.55	177
100-508	A4B-A4C14	2"	5.00	3.65	2.79	3.17	F05/F07	0.55	222
100-509	FABRICATED	2-1/2"	6.06			FABRICATED			354
100-510	FABRICATED	3"	7.08			FABRICATED			442

T-100NE									
PART NUMBER	BRACKET & COUPLER	SIZE	A	B	C	D	ISO	SQ	TORQUE (IN LBS)
100-701	A1B-A1C11	1/4"	1.86	1.77	1.97	1.26	F03/F05	0.43	23
100-702	A1B-A1C11	3/8"	1.86	1.77	1.97	1.26	F03/F05	0.43	23
100-703	A1B-A1C11	1/2"	2.45	1.95	1.97	1.50	F03/F05	0.43	35
100-704	A2B-A2C11	3/4"	2.71	2.10	1.97	1.43	F03/F04/F05	0.43	62
100-705	A3B-A3C11	1"	3.30	2.63	1.97	2.12	F05	0.43	89
100-706	A3B-A3C11	1-1/4"	3.80	2.81	1.97	2.35	F05	0.43	132
100-707	A4B-A4C14	1-1/2"	4.16	2.84	2.79	2.44	F05/F07	0.55	177
100-708	A4B-A4C14	2"	5.00	3.65	2.79	3.17	F05/F07	0.55	222
100-709	FABRICATED	2-1/2"	6.06			FABRICATED			354
100-710	FABRICATED	3"	7.08			FABRICATED			442
100-711	FABRICATED	4"	8.57			FABRICATED			620

DIRECT MOUNT VALVES



A1000

3 PIECE • 4 BOLT • FULL PORT • THREADED CONNECTION • 1000 WOG
ISO MOUNTING PAD

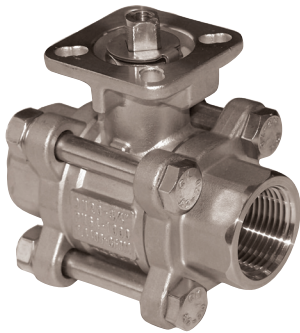

A1000 V-Ball
Available Separately

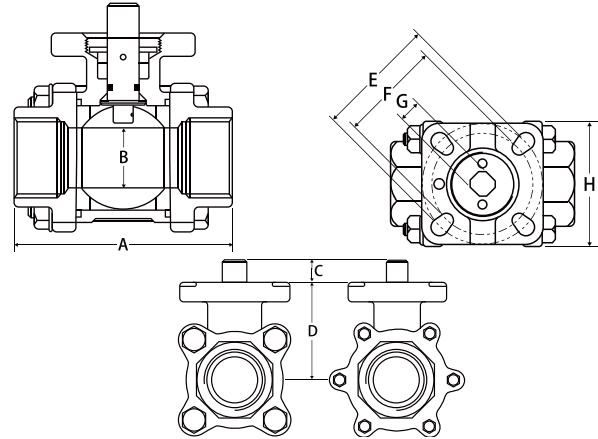

- Blow out proof stem
- Adjustable stem packing
- ISO 5211 mounting pad
- 3 piece swing out body
- Wetted surfaces contain less than .25% lead content

VALVE SEAT RATINGS

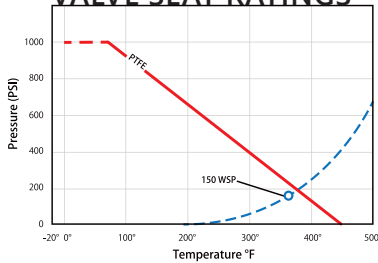

PART NUMBER	SIZE	A	B	C	D	E	F	G	H	TORQUE
A1000-14	1/4"	2.56	0.39	0.28	1.65	F04	F03	0.35	1.83	40
A1000-38	3/8"	2.56	0.39	0.28	1.65	F04	F03	0.35	1.83	40
A1000-12	1/2"	2.96	0.63	0.35	1.57	F04	F03	0.35	1.65	40
A1000-34	3/4"	3.15	0.88	0.35	1.73	F04	F03	0.35	1.65	60
A1000-1	1"	3.55	1.13	0.43	2.04	F05	F04	0.43	1.97	70
A1000-114	1-1/4"	4.33	1.38	0.43	2.28	F05	F04	0.43	1.97	110
A1000-112	1-1/2"	4.75	1.63	0.55	2.67	F07	F05	0.55	2.75	170
A1000-2	2"	5.52	1.97	0.55	3.00	F07	F05	0.55	2.75	250
A1000-212	2-1/2"	7.29	2.55	0.70	3.86	F10	F07	0.67	4.01	650
A1000-3	3"	8.00	3.00	0.70	4.33	F10	F07	0.67	4.01	850
A1000-4	4"	9.50	3.93	0.94	4.96	F12	F10	0.86	4.92	950

A1001

2 PIECE • FULL PORT • THREADED CONNECTION • 1000 WOG
ISO MOUNTING PAD



- ISO 5211 direct mounting pad
- Blow out proof stem
- 100 % leak tested
- Wetted surface contains less than .25% lead content
- Locking device may be locked in open or closed position

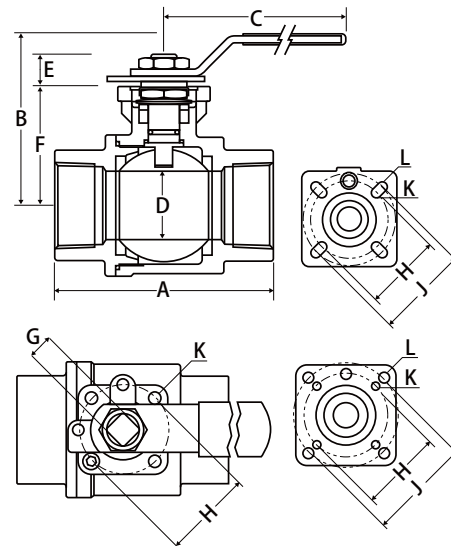

VALVE SEAT RATINGS

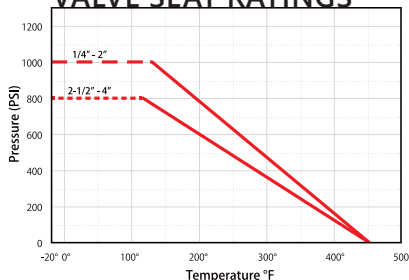

PART NUMBER	SIZE	A	B	C	D	E	F	G	H	J	K	L	TORQUE
A1001-14	1/4"	2.22	2.60	5.12	0.43	0.35	1.46	0.35	F03	F04	0.24	0.24	53
A1001-38	3/8"	2.22	2.60	5.12	0.49	0.35	1.46	0.35	F03	F04	0.24	0.24	53
A1001-12	1/2"	2.32	2.60	5.12	0.59	0.35	1.46	0.35	F03	F04	0.24	0.24	61
A1001-34	3/4"	2.81	2.72	5.12	0.79	0.43	1.57	0.35	F03	F04	0.24	0.24	79
A1001-1	1"	3.13	3.15	6.30	0.98	0.55	1.89	0.43	F04	F05	0.24	0.28	97
A1001-114	1-1/4"	3.62	3.35	6.30	1.26	0.55	2.11	0.43	F04	F05	0.24	0.28	123
A1001-112	1-1/2"	4.11	3.86	8.07	1.50	0.71	2.50	0.55	F05	-	0.28	-	256
A1001-2	2"	4.86	4.17	8.07	1.97	0.71	2.83	0.55	F05	-	0.28	-	327

A751T/L 3-WAY • STANDARD PORT • THREADED CONNECTION • 400 WOG ISO 5211 DIRECT MOUNTING PAD

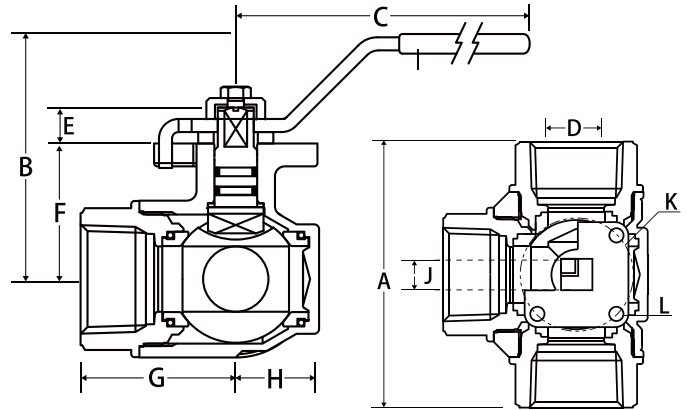

- ISO 5211 direct mounting pad
- Four seat design
- Temperatures to 344°F
- Blow-out proof stem
- Square valve stem for direct mounting to any ISO actuator

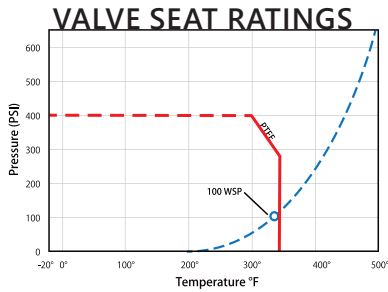

PART NUMBER	SIZE	A	B	C	D	E	F	G	H	J	K	L	TORQUE
A750_-14*	1/4"	2.64	2.44	4.72	0.39	0.20	1.20	1.32	0.77	0.35	F03	0.23	54
A750_-38*	3/8"	2.64	2.44	4.72	0.43	0.20	1.20	1.32	0.77	0.35	F03	0.23	54
A751_-12	1/2"	2.87	2.44	4.72	0.43	0.20	1.20	1.44	0.77	0.35	F03	0.23	54
A751_-34	3/4"	3.19	2.52	4.72	0.59	0.20	1.29	1.60	0.87	0.35	F03	0.23	54
A751_-1	1"	3.74	2.95	6.69	0.79	0.28	1.63	1.87	1.00	0.43	F05	0.27	151
A751_-114	1-1/4"	4.39	3.17	6.69	0.98	0.28	1.85	2.20	1.22	0.43	F05	0.27	151
A751_-112	1-1/2"	4.86	3.66	6.69	1.26	0.28	2.34	2.43	1.79	0.43	F05	0.27	151
A751_-2	2"	5.73	4.43	9.05	1.57	0.32	2.90	2.87	1.75	0.55	F07	0.35	275
A750_-212*	2-1/2"	6.93	4.86	9.05	1.95	0.32	3.35	3.47	22.00	0.55	F07	0.35	381
A750_-3*	3"	7.08	4.86	9.05	1.95	0.32	3.35	3.54	2.20	0.55	F07	0.35	381

_ = Must specify ball: T = T-Port, L = L-Port | * 1/4" - 3/8" and 2-1/2" - 3" are model A750

A766T/L FULL PORT • 3-WAY FLANGED CONNECTION • CLASS 150

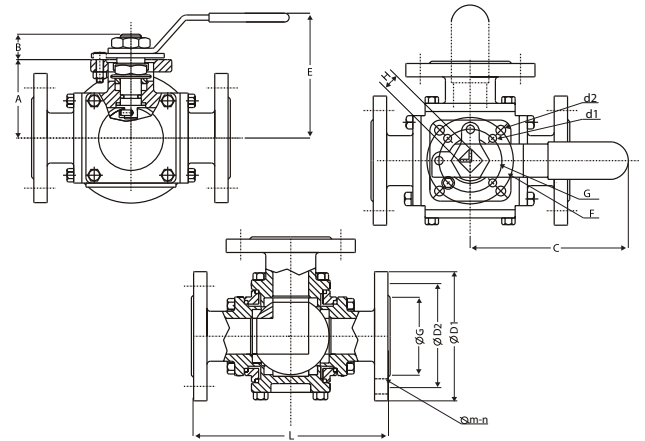

- Compact design
- AISI 316 stainless steel
- ANSI 150 flanged
- Max Temp 450°F
- Blow out proof stem
- 100% tested
- L-port & T-port available
- Wetted surface contains less than .25% lead content

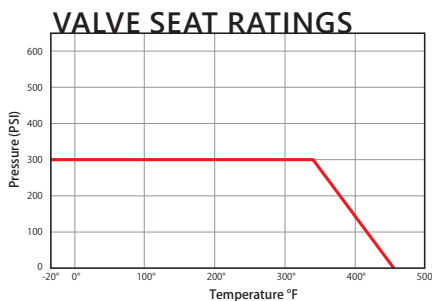

PART NUMBER	SIZE	A	B	C	D1	D2	d1	d2	E	F	G	H	L	M	N
A766T/L-12	1/2"	1.61	0.43	5.12	3.50	2.38	0.24	0.24	2.44	1.65	1.42	0.35	5.98	0.63	4
A766T/L-34	3/4"	1.93	0.55	6.50	3.86	2.76	0.24	0.28	3.23	1.97	1.65	0.43	6.57	0.63	4
A766T/L-1	1"	2.17	0.55	6.50	4.25	3.13	0.24	0.28	3.50	1.97	1.65	0.43	7.48	0.63	4
A766T/L-114	1-1/4"	2.48	0.67	8.07	4.61	3.50	0.28	0.36	3.86	2.76	1.97	0.55	8.19	0.63	4
A766T/L-112	1-1/2"	2.91	0.63	8.07	5.00	3.88	0.28	0.36	4.25	2.76	1.97	0.55	8.66	0.63	4
A766T/L-2	2"	3.66	0.83	12.80	5.98	4.74	0.36	0.45	5.51	4.02	2.76	0.67	9.96	0.63	4
A766T/L-212	2-1/2"	4.67	0.98	15.75	7.01	5.49	0.43	-	-	-	4.02	0.87	11.81	0.75	4
A766T/L-3	3"	5.37	0.98	19.69	7.48	6.00	0.43	-	-	-	4.02	0.87	12.01	0.75	4
A766T/L-4	4"	6.16	0.98	25.59	9.01	7.50	0.43	-	-	-	4.02	0.87	14.51	0.75	8

DIRECT MOUNT VALVES



A850T/L

3-WAY • FULL PORT • THREADED CONNECTION • 1000 WOG • ISO MOUNTING PAD



- ISO 5211 mounting pad
- Self adjusting stem packing
- Blow-out proof stem design
- Temperature range: -20°F to 450°F
- Four seat standard
- Locking device may be locked in open or closed position
- 100% tested
- Wetted surface contains less than .25% lead content

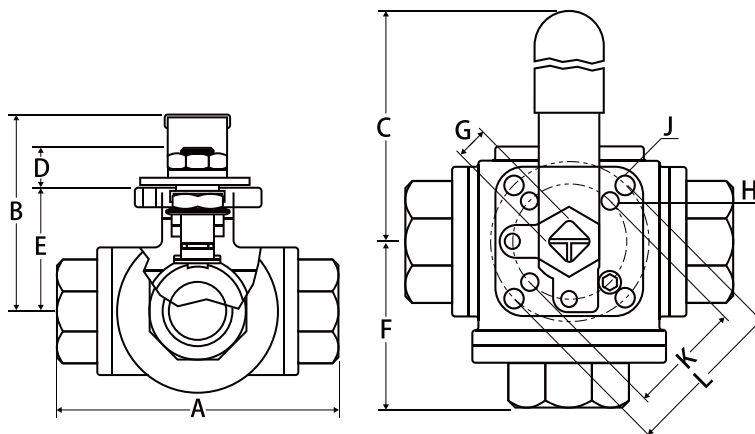

VALVE SEAT RATINGS

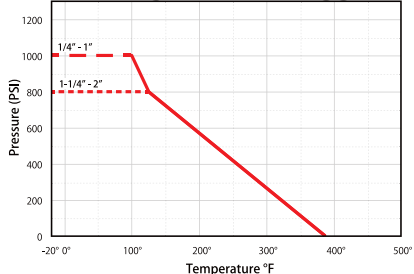

PART NUMBER	SIZE	A	B	C	D	E	F	G	H	J	K	L	PORT TORQUE	
A850_-14	1/4"	2.83	2.44	5.12	0.37	1.46	1.38	0.35	0.24	0.24	1.42	1.65	0.43	107
A850_-38	3/8"	2.83	2.44	5.12	0.37	1.46	1.38	0.35	0.24	0.24	1.42	1.65	0.47	107
A850_-12	1/2"	3.33	2.52	5.12	0.43	1.65	1.59	0.35	0.24	0.24	1.42	1.65	0.59	133
A850_-34	3/4"	3.94	3.23	6.50	0.55	1.93	1.95	0.43	0.24	0.28	1.65	1.97	0.79	160
A850_-1	1"	4.45	3.50	6.50	0.55	2.17	2.22	0.43	0.24	0.28	1.65	1.97	0.98	293
A850_-114	1-1/4"	4.94	3.86	8.07	0.67	2.48	2.44	0.55	0.28	0.36	1.97	2.76	1.26	532
A850_-112	1-1/2"	5.91	4.25	8.07	0.63	2.91	2.89	0.55	0.28	0.36	1.97	2.76	1.50	664
A850_-2	2"	6.85	5.51	12.80	0.83	3.62	3.43	0.67	0.36	0.45	2.76	4.02	1.97	744

_ = MUST SPECIFY BALL: T = T-PORT, L = L-PORT

FLOW PATTERNS FOR A751T/L • A766T/L • A850T/L

LEVER ASSEMBLY	T-port				L-port		
	POSITION 1						
POSITION 2							

A2020D

2 PIECE • FULL PORT • FLANGED CONNECTION • CLASS 150 • ISO MOUNTING PAD

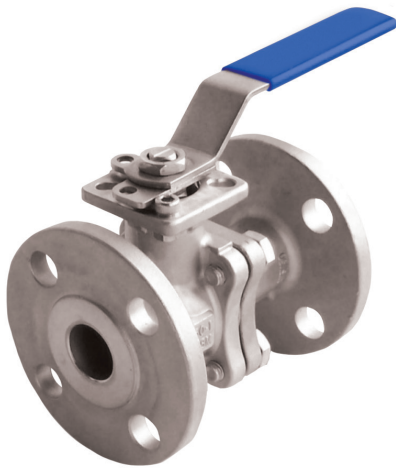

A2020D V-Ball
Available Separately

- ISO 5211 direct mounting pad
- Blow-out proof stem
- locking device comes standard
- 100% leak tested
- Wetted surfaces contain less than .25% lead content

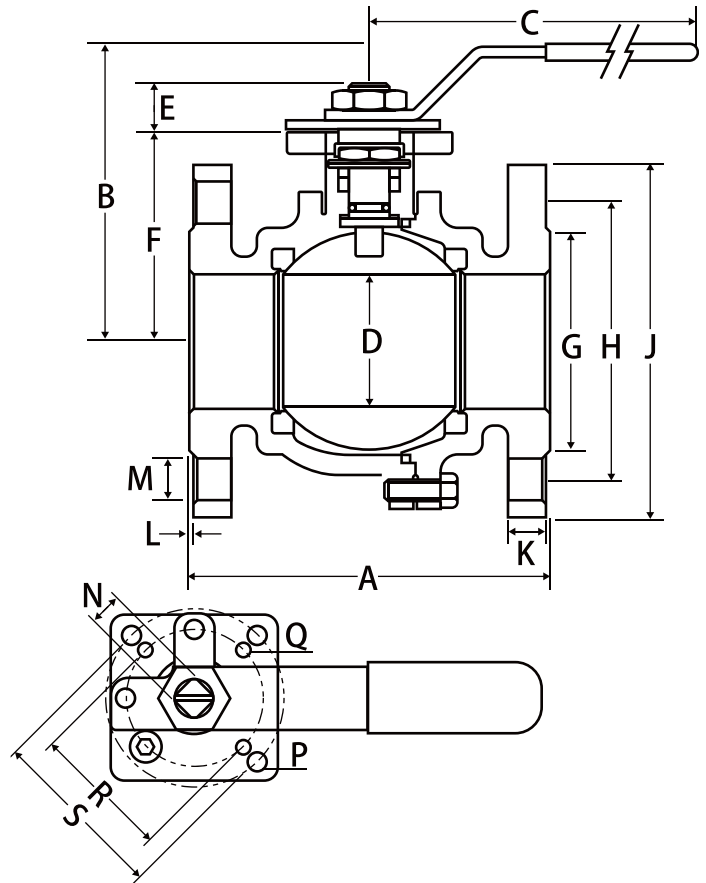

VALVE SEAT RATINGS

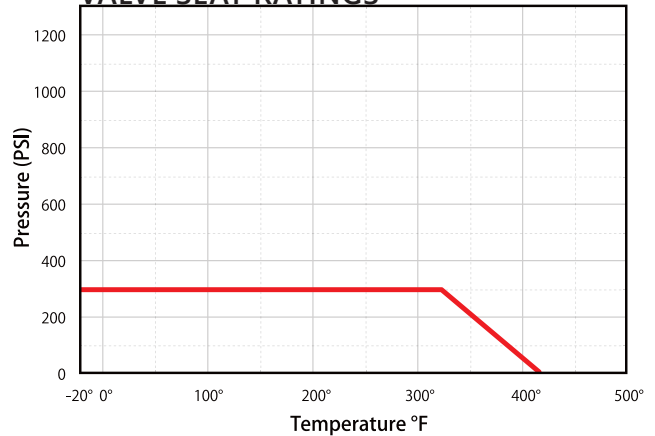

PART NUMBER	SIZE	DIMENSIONS																BOLTS	TORQUE	
		A	B	C	D	E	F	G	H	J	K	L	M	N	P	Q	R			S
A2020D-12	1/2"	4.25	3.15	5.12	0.59	0.43	1.89	1.38	2.38	3.50	0.45	0.06	0.63	0.35	0.24	0.24	1.42	1.65	4	63.7
A2020D-34	3/4"	4.61	3.15	5.12	0.79	0.43	2.09	1.69	2.76	3.86	0.45	0.06	0.63	0.35	0.24	0.24	1.42	1.65	4	83.2
A2020D-1	1"	5.00	3.54	6.50	0.98	0.55	2.32	2.01	3.13	4.25	0.45	0.06	0.63	0.43	0.28	0.24	1.65	1.97	4	117
A2020D-114	1-1/4"	5.51	4.02	6.50	1.26	0.55	2.80	2.52	3.50	4.61	0.50	0.06	0.63	0.43	0.28	0.24	1.65	1.97	4	161
A2020D-112	1-1/2"	6.50	4.33	8.07	1.50	0.71	2.99	2.87	3.88	5.00	0.56	0.06	0.63	0.55	0.36	0.28	1.97	2.76	4	266
A2020D-2	2"	7.01	4.72	8.07	1.97	0.71	3.35	3.62	4.74	5.98	0.63	0.06	0.75	0.55	0.36	0.28	1.97	2.76	4	319
A2020D-212	2-1/2"	7.48	5.51	11.81	2.56	0.91	3.68	4.13	5.49	7.01	0.70	0.06	0.75	0.67	0.45	0.36	2.76	4.02	4	841
A2020D-3	3"	7.99	5.91	13.39	3.15	0.91	4.06	5.00	6.00	7.48	0.75	0.06	0.75	0.67	0.45	0.36	2.76	4.02	4	1170
A2020D-4	4"	9.02	7.09	16.54	3.94	0.98	5.20	6.18	7.50	9.02	0.94	0.06	0.75	0.87	0.53	0.45	4.02	4.92	8	2170

2001N-4B Applicable Models: T-SS-2001N-4B, S-SS-2001N-4B, T-CS-2001N-SS-4B, S-CS-2001N-SS-4B
3 PIECE 4 BOLT ENCLOSED • STANDARD PORT • 2000 WOG
THREADED OR SOCKET WELD CONNECTION

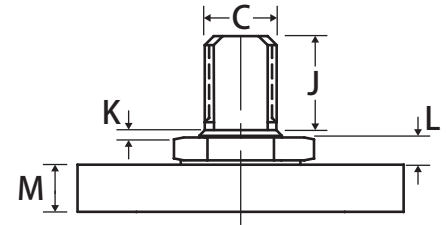
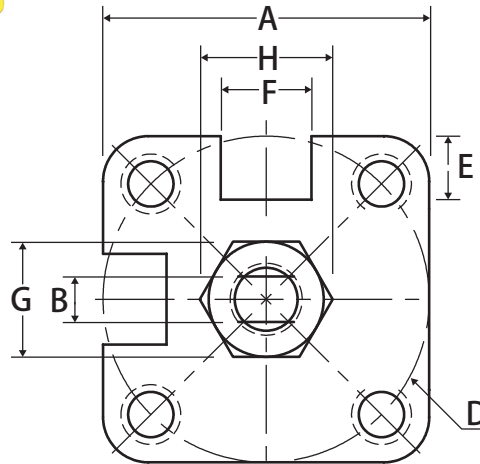

SIZE	A	B	C	D	E	F	G		H		J	K	L	M
							SS	CS	SS	CS				
1/2"	1.42	0.20	0.31	1.42	0.28	0.39	0.55	0.55	0.64	0.64	0.41	0.01	0.09	0.20
3/4"	1.42	0.20	0.31	1.42	0.28	0.39	0.55	0.55	0.64	0.64	0.41	0.01	0.09	0.22
1"	1.65	0.28	0.44	1.65	0.31	0.51	0.75	0.75	0.86	0.86	0.60	0.02	0.13	0.23
1-1/4"	1.65	0.31	0.50	1.65	0.31	0.51	0.75	0.75	0.86	0.86	0.63	0.03	0.22	0.23
1-1/2"	1.97	0.39	0.62	1.97	0.35	0.79	0.87	0.91	1.00	1.01	0.69	0.03	0.24	0.27
2"	1.97	0.39	0.62	1.97	0.35	0.79	0.87	0.91	1.00	1.01	0.69	0.05	0.24	0.28

2002N-DUE Applicable Models: T-SS-2002N-DUE, S-SS-2002N-DUE, T-CS-2002N-SS-DUE, S-CS-2002N-SS-DUE
5 PIECE • FULL PORT • DOUBLE UNION END • 3000 WOG
THREADED OR SOCKET WELD CONNECTION

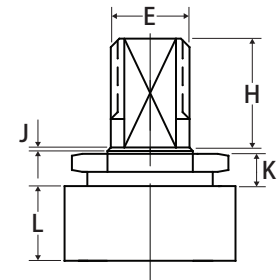
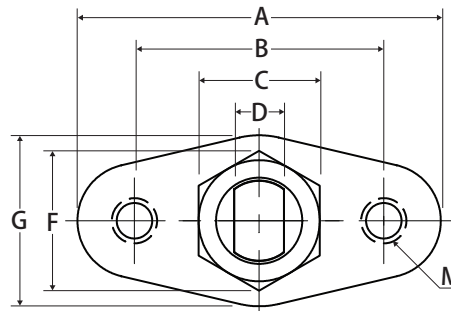

SIZE	A	B	C		D	E	F		G	H	J	K	L	M
			SS	CS			SS	CS						
1/4"	1.65	1.12	0.55	0.55	0.20	0.31	0.64	0.64	0.83	0.41	0.02	0.19	0.28	1/4" - 20UNC
3/8"	1.65	1.12	0.55	0.55	0.20	0.31	0.64	0.64	0.83	0.41	0.02	0.19	0.28	1/4" - 20UNC
1/2"	1.65	1.12	0.55	0.55	0.20	0.31	0.64	0.64	0.83	0.41	0.02	0.19	0.28	1/4" - 20UNC
3/4"	2.01	1.38	0.75	0.75	0.28	0.44	0.86	0.86	0.94	0.60	0.02	0.20	0.41	1/4" - 20UNC
1"	2.01	1.38	0.75	0.75	0.28	0.44	0.86	0.86	0.87	0.60	0.02	0.20	0.43	1/4" - 20UNC
1-1/4"	2.80	2.00	0.91	0.87	0.35	0.57	1.05	1.00	1.18	0.71	0.00	0.21	0.43	1/4" - 20UNC
1-1/2"	2.80	2.00	0.91	0.87	0.35	0.57	1.05	1.00	1.18	0.67	0.02	0.21	0.43	1/4" - 20UNC
2"	2.80	2.00	1.02	1.00	0.35	0.57	1.18	1.15	1.18	0.71	0.02	0.27	0.43	1/4" - 20UNC

1000N-4B Applicable Models: T-SS-1000N-4B, S-SS-1000N-4B, T-CS-1000N-SS-4B, S-CS-1000N-SS-4B
3 PIECE 4 BOLT • SWING OUT BODY • FULL PORT • 1000 WOG
THREADED OR SOCKET WELD CONNECTION

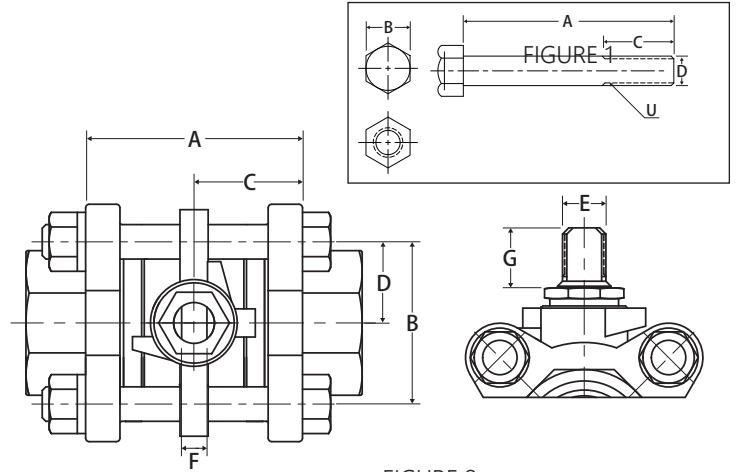
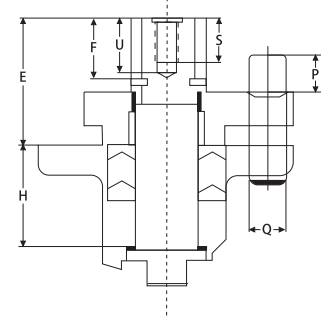
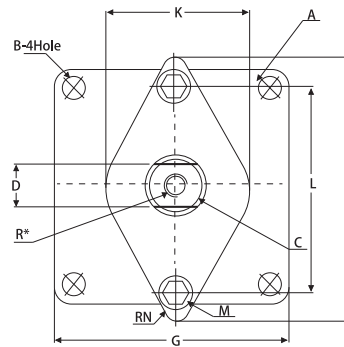

FIGURE 2

FIGURE 1 DIMENSIONS							
SIZE	A ±2	B MAX	B MIN	C ±4	D MAX	D MIN	U
1/4" - 3/8"	2.00	0.44	0.43	0.75	0.25	0.24	1/4" - 20 UNC
1/2"	2.00	0.50	0.48	0.87	0.31	0.30	5/16" - 18 UNC
3/4"	2.37	0.50	0.48	0.87	0.31	0.30	5/16" - 18 UNC
1"	2.83	0.56	0.54	0.87	0.37	0.36	3/8" - 16 UNC
1-1/4"	3.25	0.56	0.54	1.00	0.37	0.36	3/8" - 16 UNC
1-1/2"	3.74	0.63	0.60	1.26	0.44	0.43	7/16" - 14 UNC
2"	4.37	0.75	0.73	1.34	0.50	0.49	1/2" - 13 UNC
2-1/2"	5.51	0.75	0.73	1.26	0.50	0.49	1/2" - 13 UNC
3"	6.25	0.93	0.91	1.18	0.62	0.61	5/8" - 11 UNC

FIGURE 2 DIMENSIONS							
SIZE	A	B	C	D	E	F	G
1/4"	1.46	1.11	0.73	0.56	0.31	0.20	0.33
3/8"	1.46	0.43	0.73	0.56	0.31	0.20	0.33
1/2"	1.64	1.28	0.82	0.64	0.31	0.20	0.39
3/4"	1.85	1.50	0.93	0.75	0.44	0.28	0.60
1"	2.33	1.84	1.17	0.92	0.44	0.28	0.60
1-1/4"	2.69	2.12	1.34	1.06	0.57	0.35	0.71
1-1/2"	3.08	2.48	1.54	1.24	0.57	0.35	0.67
2"	3.70	2.99	1.85	1.50	0.57	0.35	0.63
2-1/2"	4.57	3.70	2.28	1.85	0.64	0.39	0.91
3"	5.20	4.40	2.60	2.20	0.64	0.39	0.91
4"	6.02	3.78	3.01	1.89	0.91	0.55	0.96

FL-CS/SS-150 Applicable Models: FL-CS-100-150, FL-SS-100-150 2 PIECE • FULL PORT • FLANGED CONNECTION



DIMENSIONS																			
SIZE	A	B-4HOLE	C	D	E	F	G	H	K	L	M	N	P	Q	R	R*	S	U	ISO 5211
1/2"	1.97	M6X1	0.47	0.31	0.64	0.19	2.00	1.34	1.10	1.50	0.39	0.25	0.24	1/4" - 20	2.00	M5X0.8	0.39	0.47	F05
3/4"	1.97	M6X1	0.47	0.31	0.76	0.30	2.00	1.52	1.10	1.50	0.39	0.25	0.24	1/4" - 20	2.00	M5X0.8	0.39	0.47	F05
1"	2.76	M8X1.25	0.59	0.39	1.07	0.52	2.68	1.80	1.35	1.83	0.47	0.30	0.30	5/16" - 18	2.44	M6X1	0.39	0.47	F07
1-1/2"	2.76	M8X1.25	0.75	0.55	1.31	0.68	2.97	2.40	1.71	2.22	0.55	0.38	0.36	3/8" - 16	2.97	M8X1.25	0.47	0.59	F07
2"	2.76	M8X1.25	0.75	0.55	1.31	0.68	2.97	2.72	1.71	2.22	0.55	0.38	0.36	3/8" - 16	2.97	M8X1.25	0.47	0.59	F07
2-1/2"	2.76	M8X1.25	0.75	0.55	1.31	0.68	2.68	3.15	1.71	2.22	0.55	0.46	0.36	3/8" - 16	3.14	M8X1.25	0.47	0.59	F07
3"	4.02	M10X1.5	0.94	0.63	1.75	0.96	3.75	3.79	2.09	2.83	0.71	0.46	0.48	1/2" - 12	3.75	M8X1.25	0.59	0.75	F10
4"	4.02	M10X1.5	1.18	0.79	1.83	0.96	4.33	4.72	2.31	3.08	0.94	0.63	0.63	5/8" - 11	4.33	M8X1.25	0.59	0.75	F10
5"	4.02	M10X1.5	1.18	0.79	1.86	0.96	3.78	5.91	2.31	3.08	0.94	0.63	0.63	5/8" - 11	4.33	M8X1.25	0.59	0.75	F10
6"	4.92	M12X1.75	1.50	1.02	2.48	0.28	4.53	7.24	2.82	3.94	0.94	0.57	0.63	5/8" - 11	5.08	-	-	-	F12
8"	5.51	M16X2	1.89	1.26	3.01	1.66	5.41	9.35	3.35	4.72	0.94	0.61	0.63	5/8" - 11	5.94	-	-	-	F14
10"	6.50	M20X2.5	2.28	1.57	3.35	1.77	6.50	11.69	3.94	5.51	1.18	0.77	0.79	M20X2.5	7.05	-	-	-	F16
12"	6.50	M20X2.5	2.76	1.77	3.83	2.13	6.50	13.68	4.68	5.91	1.18	0.77	0.79	M20X2.5	7.44	-	-	-	F16

FL-CS/SS-300 Applicable Models: FL-CS-100-300, FL-SS-100-300 2 PIECE • FULL PORT • FLANGED CONNECTION

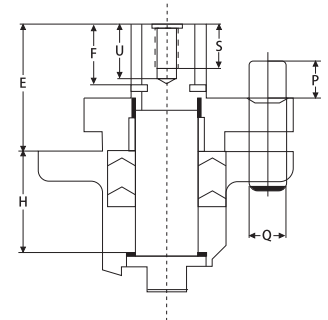
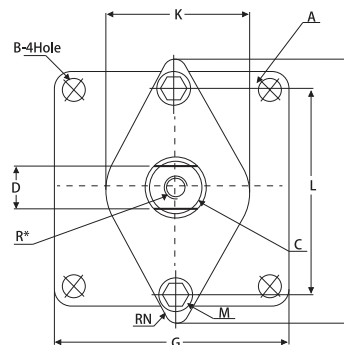

DIMENSIONS															
SIZE	A	B-4HOLE	C	D	E	F	G	H	K	L	M	N	P	Q	ISO 5211
1/2"	1.97	M6X1	0.47	0.31	0.76	0.30	1.89	1.52	1.10	1.50	0.39	0.25	0.24	1/4" - 20	F05
3/4"	1.97	M6X1	0.47	0.31	0.76	0.30	1.89	1.52	1.10	1.50	0.39	0.25	0.24	1/4" - 20	F05
1"	2.76	M6X1	0.59	0.39	1.07	0.52	1.97	1.79	1.35	1.83	0.47	0.30	0.30	5/16" - 18	F05
1-1/2"	2.76	M8X1.25	0.75	0.55	1.31	0.68	2.68	2.40	1.71	2.22	0.55	0.38	0.36	3/8" - 16	F07
2"	2.76	M8X1.25	0.75	0.55	1.31	0.68	2.68	2.92	1.71	2.22	0.55	0.38	0.36	3/8" - 16	F07
2-1/2"	2.76	M10X1.5	0.75	0.63	0.17	0.96	3.78	3.41	2.09	2.83	0.71	0.46	0.48	1/2" - 12	F10
3"	4.02	M10X1.5	0.94	0.63	1.75	0.96	3.70	3.79	2.09	2.83	0.71	0.46	0.48	1/2" - 12	F10
4"	4.02	M10X1.5	1.18	0.79	1.81	0.96	3.62	4.06	2.31	3.08	0.94	0.63	0.63	5/8" - 11	F10
5"	4.02	M10X1.5	1.18	0.79	1.82	0.96	3.62	5.00	2.31	3.08	0.94	0.63	0.63	5/8" - 11	F10
6"	4.92	M12X1.75	1.50	1.02	2.48	0.28	4.53	7.17	2.82	3.94	0.94	0.57	0.57	5/8" - 11	F12
8"	5.51	M16X2	1.89	1.26	3.01	1.66	5.41	9.19	3.35	4.72	0.94	0.61	0.61	5/8" - 11	F14

1001N Applicable Models: T-SS-1001N, T-CS-1001N-SS
2 PIECE • FULL PORT • THREADED CONNECTION • 1000 WOG

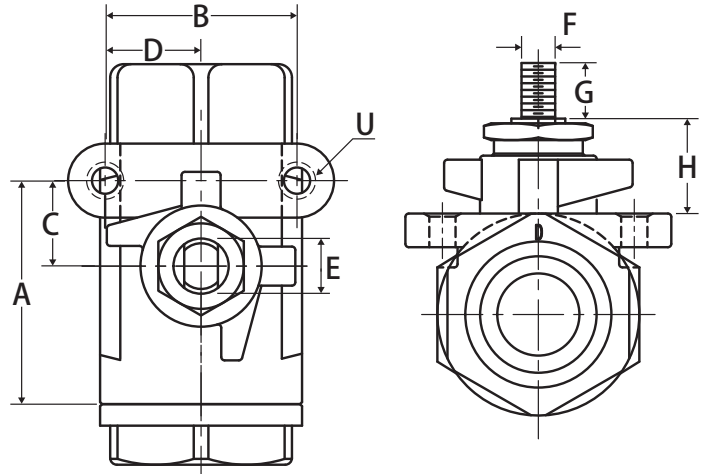
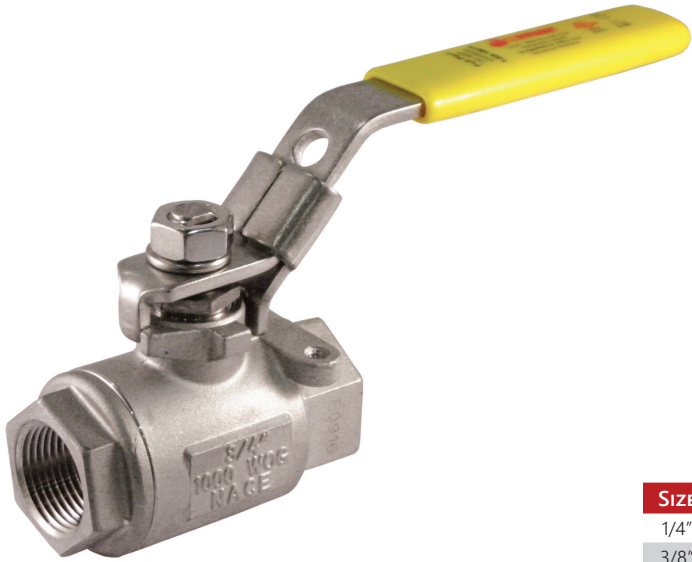

Size	A	B	C	D	E	F	G	H	U
1/4"	1.21	1.13	0.50	0.56	0.31	0.20	0.33	0.47	10# - 24UNC
3/8"	1.21	1.13	0.50	0.56	0.31	0.20	0.33	0.47	10# - 24UNC
1/2"	1.31	1.38	0.50	0.69	0.31	0.20	0.39	0.55	10# - 24UNC
3/4"	1.83	1.38	0.87	0.69	0.44	0.28	0.60	0.69	10# - 24UNC
1"	1.99	1.50	0.87	0.75	0.44	0.28	0.60	0.67	1/4" - 20UNC
1-1/4"	2.19	1.50	0.93	0.75	0.57	0.35	0.71	0.77	1/4" - 20UNC
1-1/2"	2.39	1.50	0.93	0.75	0.57	0.35	0.67	0.77	1/4" - 20UNC
2"	2.65	1.50	1.00	0.75	0.57	0.35	0.71	0.83	1/4" - 20UNC

2000N Applicable Models: T-SS-2000N, T-CS-2000N-SS
2 PIECE • FULL PORT • THREADED CONNECTION • 2000 WOG

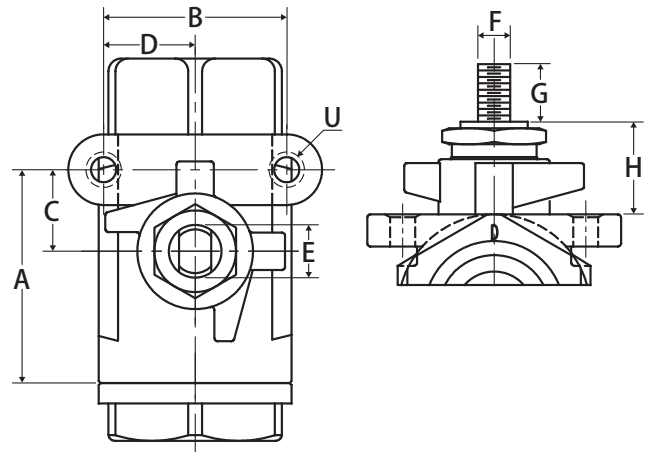

Size	A	B	C	D	E	F	G	H	U
1/4"	1.25	1.12	0.50	0.56	0.31	0.20	0.33	0.51	10# - 24UNC
3/8"	1.25	1.12	0.50	0.56	0.31	0.20	0.33	0.51	10# - 24UNC
1/2"	1.31	1.12	0.50	0.56	0.31	0.20	0.39	0.54	10# - 24UNC
3/4"	1.82	1.38	0.87	0.69	0.44	0.28	0.60	0.71	10# - 24UNC
1"	1.93	1.38	0.87	0.69	0.44	0.28	0.60	0.69	10# - 24UNC
1-1/4"	2.08	1.50	0.93	0.57	0.75	0.35	0.71	0.74	1/4" - 20UNC
1-1/2"	2.25	1.50	0.93	0.57	0.75	0.35	0.71	0.75	1/4" - 20UNC
2"	2.46	1.50	0.93	0.57	0.75	0.35	0.67	0.76	1/4" - 20UNC

ACTUATION TECHNICAL TABLES



JV SERIES SPRING RETURN OUTPUT TORQUE (IN-LB)											
AS SIZE	SPRING No	40 PSI		60 PSI		80 PSI		100 PSI		SPRING TORQUE	
		AIR START	AIR END	AIR START	AIR END	AIR START	AIR END	AIR START	AIR END	SPRING START	SPRING END
		0	90	0	90	0	90	0	90	90	0
JV-50	6	51	33	96	78	141	123	186	168	57	39
	7	45	23	90	68	135	113	180	158	67	45
	8			83	58	128	103	173	148	77	52
	9			77	49	122	94	167	139	86	58
	10					116	84	161	129	96	64
	11					109	75	154	120	105	71
	12							148	110	115	77
JV-60	6	105	67	196	158	287	249	379	341	116	78
	7	91	47	182	138	273	229	365	321	136	92
	8			169	119	260	210	352	302	155	105
	9			156	99	247	190	339	282	175	118
	10					234	171	326	263	194	131
	11					221	152	313	244	213	144
	12							300	224	233	157
JV-70	6	162	103	314	245	445	386	587	528	181	122
	7	142	73	294	215	425	356	567	498	211	142
	8			274	185	405	326	547	468	241	162
	9			253	155	384	296	526	438	271	183
	10					364	266	506	408	301	203
	11					344	236	486	378	331	223
	12							465	347	362	244
JV-80	6	237	151	446	360	654	568	862	776	265	179
	7	207	106	416	315	624	523	832	731	310	209
	8			386	271	594	479	802	687	354	239
	9			357	227	565	435	773	643	398	268
	10					535	391	743	599	442	298
	11					505	347	713	555	486	328
	12							683	510	531	358
JV-90	6	334	212	627	505	919	797	1212	1090	373	251
	7	292	150	585	443	877	735	1170	1028	435	293
	8			543	381	835	673	1128	966	497	335
	9			501	319	793	611	1086	904	559	377
	10					751	549	1044	842	621	419
	11					709	486	1002	779	684	461
	12							960	717	746	503
JV-100	6	448	285	840	677	1232	1069	1624	1461	500	337
	7	392	202	784	594	1176	986	1568	1378	583	393
	8			728	510	1120	902	1512	1294	667	449
	9			671	427	1063	819	1455	1211	750	506
	10			615	344	1007	736	1399	1128	833	562
	11					951	652	1343	1044	917	618
	12							1287	961	1000	674
JV-120	6	448	285	1446	1165	2122	1841	2797	2516	861	580
	7	674	347	1349	1022	2025	1698	2700	2373	1004	677
	8			1252	878	1928	1554	2603	2229	1148	774
	9			1156	735	1832	1411	2507	2086	1291	870
	10					1735	1267	2410	1942	1435	967
	11					1638	1124	2313	1799	1578	1064
	12							2216	1656	1721	1161

Torque in lbs.

JV SERIES SPRING RETURN OUTPUT TORQUE (IN-LB)											
AS SIZE	SPRING No	40 PSI		60 PSI		80 PSI		100 PSI		SPRING TORQUE	
		AIR START	AIR END	AIR START	AIR END	AIR START	AIR END	AIR START	AIR END	SPRING START	SPRING END
		0	90	0	90	0	90	0	90	90	0
JV-140	6	967	615	1814	1462	2661	2309	3508	3156	1080	728
	7	846	435	1693	1282	2540	2129	3387	2976	1260	849
	8			1571	1102	2418	1949	3265	2796	1440	971
	9			1450	922	2297	1769	3144	2616	1620	1092
	10					2176	1589	3023	2436	1800	1213
	11					2054	1410	2901	2257	1979	1335
	12							2780	2077	2159	1456
JV-160	6	1579	1004	2962	2387	4345	3770	5729	5154	1763	1188
	7	1380	710	2763	2093	4146	3476	5530	4860	2057	1387
	8			2565	1800	3948	3183	5332	4567	2350	1585
	9			2367	1506	3750	2889	5134	4273	2644	1783
	10					3552	2595	4936	3979	2938	1981
	11					3354	2301	4738	3685	3232	2179
	12							4540	3391	3526	2377
JV-190	6	2597	1652	4872	3927	7148	6203	9424	8479	2900	1955
	7	2271	1169	4546	3444	6822	5720	9098	7996	3383	2281
	8			4220	2960	6496	5236	8772	7512	3867	2607
	9			3894	2477	6170	4753	8446	7029	4350	2933
	10					5844	4269	8120	6545	4834	3259
	11					5518	3786	7794	6062	5317	3585
	12							7469	5579	5800	3910
JV-200	6	3262	2075	6122	4935	8981	7794	11841	10654	3644	2457
	7	2853	1468	5713	4328	8572	7187	11432	10047	4251	2866
	8			5303	3720	8162	6579	11022	9439	4859	3276
	9			4894	3113	7753	5972	10613	8832	5466	3685
	10					7343	5365	10203	8225	6073	4095
	11					6934	4757	9794	7617	6681	4504
	12							9385	7010	7288	4913
JV-240	6	5780	3676	10845	8741	15911	13807	20977	18873	6456	4352
	7	5054	2601	10119	7666	15185	12732	20251	17798	7531	5078
	8			9394	6590	14460	11656	19526	16722	8607	5803
	9			8669	5514	13735	10580	18801	15646	9683	6528
	10					13009	9504	18075	14570	10759	7254
	11					12284	8428	17350	13494	11835	7979
	12							16625	12418	12911	8704
JV-270	6	7250	4611	13605	10966	19959	17320	26314	23675	8098	5459
	7	6340	3262	12695	9617	19049	15971	25404	22326	9447	6369
	8			11785	8267	18139	14621	24494	20976	10797	7279
	9			10875	6917	17229	13271	23584	19626	12147	8189
	10					16319	11922	22674	18277	13496	9099
	11					15409	10572	21764	16927	14846	10009
	12							20854	15577	16196	10919
JV-300	6	10172	6470	19087	15385	28003	24301	36919	33217	11362	7660
	7	8896	4577	17811	13492	26727	22408	35643	31324	13255	8936
	8			16534	11598	25450	20514	34366	29430	15149	10213
	9			15257	9704	24173	18620	33089	27536	17043	11490
	10					22897	16727	31813	25643	18936	12766
	11					21620	14833	30536	23749	20830	14043
	12							29259	21856	22723	15320

SPRING RETURN OUTPUT TORQUE (IN-LB) @ 80PSI W/ 11 SPRINGS (STANDARD)				
MODEL	SQ	ISO	AIR START	SPRING END
JV-50-SR	0.43	F03/05	109	71
JV-60-SR	0.55	F05/07	221	144
JV-70-SR	0.55	F05/07	344	223
JV-80-SR	0.67	F05/07	505	328
JV-90-SR	0.67	F05/07/10	709	461
JV-100-SR	0.87	F05/07/10	951	618
JV-120-SR	0.87	F07/10	1638	1064
JV-140-SR	1.06	F07/F10/12	2054	1335
JV-160-SR	1.06	F10/12	3354	2179
JV-190-SR	1.42	F10/14	5518	3585
JV-200-SR	1.42	F10/14	6934	4504
JV-240-SR	1.81	F16	12284	7979
JV-270-SR	1.81	F16	15409	10009
JV-300-SR	1.81	F16	21620	14043

SIZE	BUTTERFLY VALVES MAX BREAK TORQUE							
	SQ	ISO	EPDM & BUNA		PTFE		VITON	
			WET	DRY	WET	DRY	WET	DRY
2"	0.35	F05	176	283	353	565	198	318
2-1/2"	0.35	F05	201	381	401	763	226	429
3"	0.35	F05	269	511	537	1022	302	575
4"	0.43	F07	464	850	928	1699	522	956
5"	0.55	F07	800	1500	1600	2900	900	1600
6"	0.55	F07	1196	2033	2392	4066	1345	2287
8"	0.67	F10	2238	3850	4476	7700	2518	4331
10"	0.86	F10	3768	6407	7537	12813	4239	7207
12"	0.87	F10	5721	9326	11443	18652	6437	10492
14"	0.87	F10	6638	10302	13276	20605	7468	11590
16"	1.06	F14	8985	13882	17971	27763	10108	15617
18"	1.06	F14	12012	18910	24024	37810	13514	21270
20"	1.42	F14	15199	24513	30397	49026	17098	27577
24"	1.42	F16	24439	39414	48877	78828	27494	44341
30"	1.77	F25	28322	42484	42484	63725	31115	46732
36"	2.17	F25	40625	60937	60937	91410	44687	67035

JV SERIES DOUBLE ACTING OUTPUT TORQUE						
MODEL	SQ	ISO	SUPPLY PRESSURE - PSI			
			40	60	80	100
JV-50-DA	0.43	F03/05	90	135	180	225
JV-60-DA	0.55	F05/07	183	274	365	457
JV-70-DA	0.55	F05/07	284	426	567	709
JV-80-DA	0.67	F05/07	416	625	833	1041
JV-90-DA	0.67	F05/07/10	585	878	1170	1483
JV-100-DA	0.87	F05/07/10	785	1177	1589	1961
JV-120-DA	0.87	F07/10	1351	2026	2702	3377
JV-140-DA	1.06	F07/10/12	1695	2542	3389	4236
JV-160-DA	1.06	F10/12	2767	4150	5533	6917
JV-190-DA	1.42	F10/14	4552	6827	9103	11379
JV-200-DA	1.42	F10/14	5719	8579	11438	14298
JV-240-DA	1.81	F16	1132	15197	20263	25329
JV-270-DA	1.81	F16	12709	19064	25418	31773
JV-300-DA	1.81	F16	17832	26747	35663	44579
JV-350-DA	1.81	F16	27282	40923	54563	68204

SIZE	BUTTERFLY VALVE CVs									
	FLOW IN GPM @ 1PSID @ VARIOUS DISC ANGLES									
	10°	20°	30°	40°	50°	60°	70°	80°	FULL 90° OPEN	
2"	0.1	5	12	24	45	64	90	125	135	135
2.5"	0.2	8	20	37	65	98	144	204	220	220
3"	0.3	12	22	39	70	116	183	275	302	302
4"	0.5	17	36	78	139	230	364	546	600	600
5"	0.8	29	61	133	237	392	620	930	1022	1022
6"	2	45	95	205	366	605	958	1437	1579	1579
8"	3	89	188	408	727	1202	1903	2854	3136	3136
10"	4	151	320	694	1237	2047	3240	4859	5340	5340
12"	5	234	495	1072	1911	3162	5005	7505	8250	8250
14"	6	338	715	1549	2761	4568	7230	10844	11917	11917
16"	8	464	983	2130	3797	6282	9942	14913	1638	1638
18"	11	615	1302	2822	5028	8320	13168	19752	21705	21705
20"	14	791	1674	3628	6465	10698	16931	25396	27908	27908
24"	22	1222	2587	5605	9989	16528	26157	39236	43116	43116

AE ELECTRIC SERIES			
MODEL	SQ	ISO	TORQUE
AE-180	.43	F03/05	180
AE-350	.55	F03/05/07	350
AE-700	.67	F05/07	700
AE-880	.67	F07	880
AE-1400	.87	F07/10	1400
AE-2100	.87	F07/10	2125
AE-3100	1.06	F10/12	3098
AE-4400	1.06	F10/12	4425
AE-7000	1.42	F12/14	7080
AE-9700	1.54	F14	9735

Spring Mounting Form for Spring Return Actuators

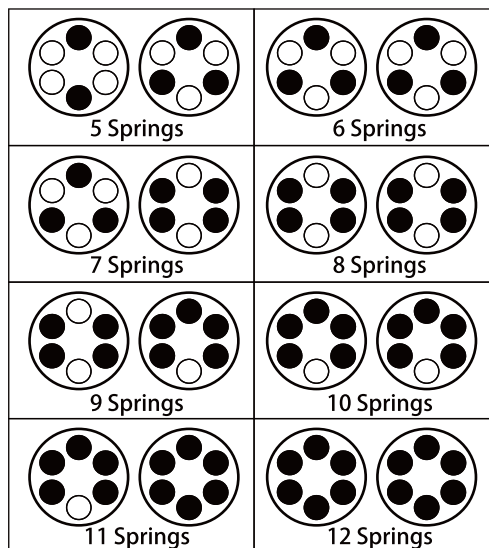

T-100 SERIES				
SIZE	TORQUE	BRACKET USED	ISO	SQ
1/4"	23	A1B-A1C11	F03/05	.43
3/8"	23	A1B-A1C11	F03/05	.43
1/2"	35	A1B-A1C11	F03/05	.43
3/4"	62	A2B-A2C11	F03/04/05	.43
1"	89	A3B-A3C11	F05	.43
1-1/4"	132	A3B-A3C11	F05	.43
1-1/2"	177	A4B-A4C14	F05/07	.55
2"	222	A4B-A4C14	F05/07	.55
2-1/2"	354		FABRICATED	
3"	442		FABRICATED	
4"	620		FABRICATED	

T-1001N		
SIZE	TORQUE	BRACKET
1/4"	40	FABRICATED
3/8"	40	FABRICATED
1/2"	40	FABRICATED
3/4"	60	FABRICATED
1"	70	FABRICATED
1-1/4"	110	FABRICATED
1-1/2"	170	FABRICATED
2"	250	FABRICATED

CLASS 150 FLANGE		
SIZE	TORQUE	BRACKET
1/2"	48	FABRICATED
3/4"	90	FABRICATED
1"	148	FABRICATED
1-1/2"	270	FABRICATED
2"	395	FABRICATED
2-1/2"	609	FABRICATED
3"	913	FABRICATED
4"	1443	FABRICATED
5"	2687	FABRICATED
6"	4870	FABRICATED
8"	8522	FABRICATED
10"	13276	FABRICATED
12"	24780	FABRICATED

T/S-1000N-4B		
SIZE	TORQUE	BRACKET
1/4"	60	FABRICATED
3/8"	60	FABRICATED
1/2"	80	FABRICATED
3/4"	150	FABRICATED
1"	250	FABRICATED
1-1/4"	320	FABRICATED
1-1/2"	400	FABRICATED
2"	480	FABRICATED
2-1/2"	600	FABRICATED
3"	850	FABRICATED
4"	1200	FABRICATED

T-2000N-SS		
SIZE	TORQUE	BRACKET
1/4"	35	FABRICATED
3/8"	35	FABRICATED
1/2"	65	FABRICATED
3/4"	100	FABRICATED
1"	120	FABRICATED
1-1/4"	210	FABRICATED
1-1/2"	300	FABRICATED
2"	400	FABRICATED

T/S-2001N-4B		
SIZE	TORQUE	BRACKET
1/2"	85	FABRICATED
3/4"	150	FABRICATED
1"	180	FABRICATED
1-1/4"	210	FABRICATED
1-1/2"	320	FABRICATED
2"	440	FABRICATED

CLASS 300 FLANGE		
SIZE	TORQUE	BRACKET
2"	1068	FABRICATED
3"	1752	FABRICATED
4"	3216	FABRICATED
6"	6900	FABRICATED
8"	16620	FABRICATED
10"	23040	FABRICATED

A1001			
SIZE	TORQUE	ISO	SQ
1/4"	53	F03/04	0.35
3/8"	53	F03/04	0.35
1/2"	61	F03/04	0.35
3/4"	79	F03/04	0.35
1"	97	F04/05	0.43
1-1/4"	123	F04/05	0.43
1-1/2"	256	F05	0.55
2"	327	F05	0.55

A2020D			
SIZE	TORQUE	ISO	SQ
1/2"	117	F03/04	0.35
3/4"	138	F03/04	0.35
1"	159	F04/05	0.43
1-1/4"	200	F04/05	0.43
1-1/2"	283	F05/07	0.55
2"	563	F05/07	0.55
2-1/2"	903	F07/10	0.67
3"	1018	F07/10	0.67
4"	1252	F10	0.87

T/S-2002N-DUE		
SIZE	TORQUE	BRACKET
1/4"	35	FABRICATED
3/8"	35	FABRICATED
1/2"	65	FABRICATED
3/4"	100	FABRICATED
1"	120	FABRICATED
1-1/4"	210	FABRICATED
1-1/2"	300	FABRICATED
2"	400	FABRICATED

A101			
SIZE	TORQUE	ISO	SQ
1/2"	16	F03	0.35
3/4"	23	F03	0.35
1"	36	F05	0.43
1-1/4"	73	F05	0.43
1-1/2"	76	F05	0.43
2"	130	F05	0.43

A1000			
SIZE	TORQUE	ISO	SQ
1/2"	40	F03/04	0.35
3/4"	60	F03/04	0.35
1"	70	F04/05	0.43
1-1/4"	110	F04/05	0.43
1-1/2"	170	F05/07	0.55
2"	250	F05/07	0.55
2-1/2"	650	F07/10	0.67
3"	850	F07/10	0.67
4"	950	F10/12	0.87

A751L/T			
SIZE	TORQUE	ISO	SQ
1/4"	54	F03	0.35
3/8"	54	F03	0.35
1/2"	54	F03	0.35
3/4"	54	F03	0.35
1"	151	F05	0.43
1-1/4"	151	F05	0.43
1-1/2"	151	F05	0.43
2"	275	F07	0.55
2-1/2"	381	F07	0.55
3"	381	F07	0.55

A850L/T			
SIZE	TORQUE	ISO	SQ
1/4"	105	F03/F04	0.35
3/8"	105	F03/F04	0.35
1/2"	138	F03/F04	0.35
3/4"	184	F04/F05	0.43
1"	323	F04/F05	0.43
1-1/4"	461	F05/F07	0.55
1-1/2"	633	F05/F07	0.55
2"	1037	F07/F10	0.67

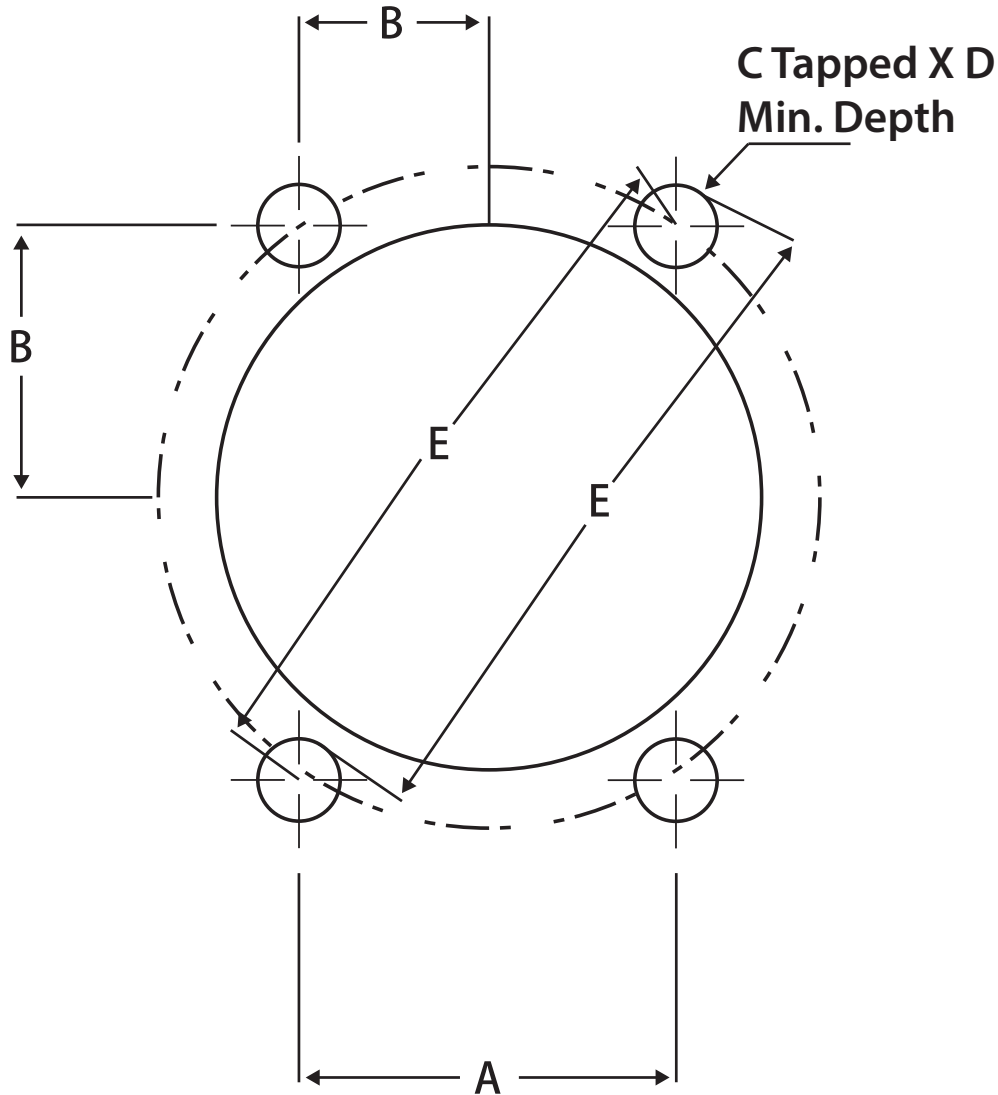

ISO TYPE	DIMENSIONS					NUMBER OF HOLES
	A	B	C	D MIN	E DIA	
F03	1.002	.501	10-24 / M5	.35	1.414	4
F04	1.170	.585	10-24 / M5	.35	1.656	4
F05	1.392	.696	1/4" / M6	.35	1.97	4
F07	1.948	.974	5/16" / M8	.47	2.756	4
F10	2.840	1.420	3/8" / M10	.59	4.02	4
F12	3.480	1.740	1/2" / M12	.71	4.92	4
F14	3.898	1.949	5/8" / M14	.94	5.51	4
F16	4.593	2.296	3/4" / M16	1.18	6.50	4
F25	7.070	3.535	5/8" / M14	.94	10.0	8
F30	8.295	4.147	3/4" / M16	1.18	11.73	8
F35	9.909	4.955	M30	1.77	14.01	8
F40	11.301	5.650	M36	2.13	15.98	8
F48	13.444	6.722	M36	2.13	19.01	12
F60	16.784	8.392	M36	2.13	23.74	20

VALVE SELECTION

MEDIA TYPE IN VALVE:

- WET DRY

MODEL _____

VALVE SIZE _____

QUANTITY _____

MAX MEDIA PRESSURE _____

MAX MEDIA TEMPERATURE _____

FREQUENCY OF OPERATION _____

VALVE TYPE

BALL MATERIAL:

- BRASS
 CARBON STEEL
 STAINLESS STEEL
 PVC

BUTTERFLY SEAT MATERIAL:

- EPDM VITON
 BUNA PTFE

CONNECTION TYPE:

- THREADED SOLDER
 FLANGED SOCKET WELD
 CLASS 150
 CLASS 300

ACTUATOR SELECTION

ELECTRIC

PROCEED TO SECTION A BELOW

SECTION A: ELECTRIC

VOLTAGE _____

ACTUATOR TYPE:

- DOUBLE ACTING (FAIL IN PLACE)
 FAIL-SAFE
 FAIL OPEN
 FAIL CLOSED
 SPRING RETURN ELECTRIC
 BATTERY BACKUP ELECTRIC

TIME FOR 90° ROTATION _____

CONTROL TYPE:

- ON/OFF
 MODULATING
 4-20MA
 0-10V
 1-5V

ENCLOSURE:

- NEMA 4
 NEMA 7
 OTHER

OPTIONS:

- AUXILIARY LIMIT SWITCHES
 BRAKE
 MANUAL OVERRIDE
 POSITION TRANSMITTER
 POTENTIOMETER
 THERMOSTAT

PNEUMATIC

PROCEED TO SECTION B BELOW

SECTION B: PNEUMATIC

ACTUATOR TYPE:

- AIR TO AIR (DOUBLE ACTING)
 AIR TO SPRING (SPRING RETURN)
 FAIL OPEN
 FAIL CLOSED

OPTIONS:

- SOLENOID VALVE
 COIL VOLTAGE COIL ENCLOSURE
 120VAC NEMA 4
 24VAC NEMA 7
 24VDC
 12VDC
 SPEED CONTROL MUFFLERS
 LIMIT SWITCH
 NEMA 4
 NEMA 7
 POSITIONER
 ELECTRO-PNEUMATIC (4-20MA)
 PNEUMATIC (3-15PSI)

Jomar VALVE®



T-100CG

T-100SSE

T-100NE

T-100SS