

# Hydraulic Unit

Model CP

Model CR

Model CS



## Air-powered Hydraulic Unit

Most suitable hydraulic source of automatic clamp / RA die lifter.

CP/CR/CS hydraulic unit is the united type of CB/CD/CC pump unit and BC non-leak valve unit. Available in three types of pumps from compact type to large flow rate type.

### Specifications

Model No.		CP□0M1	CP□0N1	CR5M31	CR5N31	CS50M0	CS50N0	
Working Hydraulic Pressure		24.5 MPa						
Withstanding Pressure		36.8 MPa						
Tank Capacity		2 : 2 ℓ ( Actual amount for use 1.1 ℓ ) 5 : 5 ℓ ( Actual amount for use 3.1 ℓ )				5 : 5 ℓ ( Actual amount for use 3.1 ℓ )		
Operating Temperature		0 ~ 70 °C						
Use Frequency		Less than 20 cycles /day			Pressure Rising Time : less than 2.5 min. / cycle			
Main Components	Pump	Model No.	AB7000-0		AD7300-0		AC7001-0	
		Set Discharge Pressure	24.5 MPa	22.5 MPa	24.5 MPa	22.5 MPa	24.5 MPa	22.5 MPa
		Discharge Volume Under No Load	1.36 ℓ /min	1.32 ℓ /min	4.00 ℓ /min	3.74 ℓ /min	2.79 ℓ /min	2.70 ℓ /min
		Set Air Pressure	0.45 MPa	0.41 MPa	0.45 MPa	0.41 MPa	0.47 MPa	0.43 MPa
		Air Consumption	max. 0.4 m <sup>3</sup> (Normal)/min				max. 1.0 m <sup>3</sup> (Normal)/min	
	Suction Filter	Model No.	JF1030					
		Filtration Degree	174 μm (100 mesh)					
	Non-Leak Valve	Model No.	BA5011-0	BA5011-0 BA5R11-0	BA5011-0	BA5011-0 BA5R11-0	BA5011-0	BA5011-0 BA5R11-0
	Pressure Switch (For Clamp)	Model No.	JB2800-M0					
		Operation Mode / Set Pressure	Pressure Increase Detection / INC. 17.6 MPa					
Pressure Switch (For RA Die Lifter)	Model No.	JB1000-M0						
	Operation Mode / Set Pressure	Pressure Decrease Detection / DEC. 2.94 MPa						
Pressure Relief Valve	Model No.	-	BR5N11-0	-	BR5N11-0	-	BR5N11-0	
	Set Pressure	-	24.5 <sup>+2.45</sup> <sub>0</sub> MPa	-	24.5 <sup>+2.45</sup> <sub>0</sub> MPa	-	24.5 <sup>+2.45</sup> <sub>0</sub> MPa	

- Notes
1. If hydraulic oil with viscosity grade higher than listed on Hydraulic Fluid List (ISO-VG-32 or equivalent), action time will be longer.
  2. If using it at low temperature action time will be longer because of high viscosity of hydraulic oil.
  3. Be sure to set an automatic drain air filter when air contains a large amount of moisture, or air supplying pipe is located at the end.
  4. When setting a pressure gauge to hydraulic circuit, install a damper or use an oil filled (glycerin) pressure gauge in order to prevent damage caused by pressure surging.
  5. Provide enough space at the bottom of the unit to compensate for hydraulic oil change.  
(Tank cleaning and suction strainer tightening becomes easier.)

## Model No. Indication

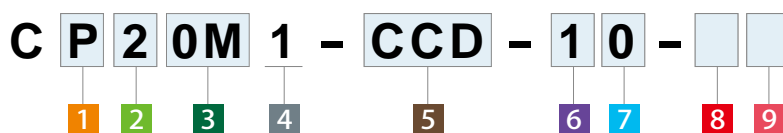

### 1 Pump (Amount of Discharge Oil)

- P** : Pump AB7000-0 (Standard Flow Rate / Compact)  
**R** : Pump AD7300-0 (Large Flow Rate)  
**S** : Pump AC7001-0 (Large Flow Rate)

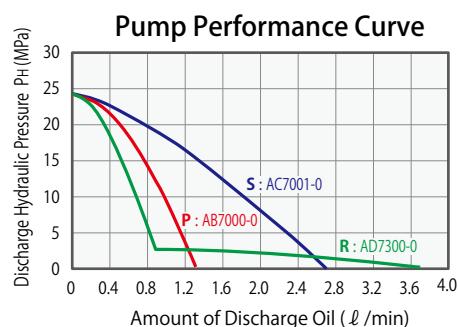

### 2 Tank Capacity

- 2** : 2 ℓ (Actual amount for use 1.1 ℓ) ※1  
**5** : 5 ℓ (Actual amount for use 3.1 ℓ)

Note

※1. **2** Tank Capacity 2 : 2 ℓ is only for **1** Pump **P**: AB7000-0, **R**: AD7300-0.

### 3 Working Pressure Code

- When selecting **1** Pump **P**  
**OM** : 24.5MPa Supply Air Pressure=0.45MPa No Pressure Relief Valve  
**ON** : 24.5MPa Supply Air Pressure=0.41MPa With Pressure Relief Valve ※2

- When selecting **1** Pump **S**  
**OM** : 24.5MPa Supply Air Pressure=0.47MPa No Pressure Relief Valve  
**ON** : 24.5MPa Supply Air Pressure=0.43MPa With Pressure Relief Valve ※2

- When selecting **1** Pump **R**  
**M3** : 24.5MPa Supply Air Pressure=0.45MPa No Pressure Relief Valve  
**N3** : 24.5MPa Supply Air Pressure=0.41MPa With Pressure Relief Valve ※2

### 4 Design No. (Revision Number)

- 0** : When selecting **1** Pump **S** : AC7001-0      **1** : When selecting **1** Pump **P** : AB7000-0, **R** : AD7300-0

### 5 Circuit Symbol ※ Please contact us for other types of circuits.

- C** : For Clamp Single Solenoid Valve (Normal Open)  
**D** : For Die Lifter Single Solenoid Valve (Normal Close)  
**U** : For Clamp Double Solenoid Valve  
**V** : For Die Lifter Double Solenoid Valve  
**G** : For Clamp Single Solenoid Valve (Normal Open) ※3  
**H** : For Die Lifter Single Solenoid Valve (Normal Close) ※3  
**R** : Pressure Relief Valve ※2

Notes

※2. When choosing **3** Pressure Code **ON, N3**: with pressure relief valve, please select **R**: Pressure relief valve at **5** Circuit Symbol after circuit symbol which requires pressure relief valve.

(Ex.) When choosing three circuits C, C, D

With three pressure relief valves on every circuit : CP20N1-CRCRDR-□-□

With pressure relief valves only on C circuits : CP20N1-CRCRD-□-□

No pressure relief valve on circuits : CP20M1-CCD-□-□

※3. Please select **5** Circuit Symbol G, H only when using it with circuit symbol U.

### 6 Control Voltage

- 1** : AC 100 V      **4** : AC 220 V  
**2** : AC 200 V      **5** : DC 24 V  
**3** : AC 110 V

### 7 Fluid Code

- 0** : General Hydraulic Oil (Equivalent to ISO-VG-32)  
**S** : Silicon Oil  
**G** : Water-Glycol (Tank is made of steel.)

※ For fluids other than described above, please contact us.

### 8 Option

- Blank** : Standard (Air Regulator)  
**D** : With Filter Regulator (Auto-Drain Type)  
**G** : With Pressure Gauge (For Primary Pressure)  
**H** : With Piping Block (PH Port)  
**Q** : With Oil Level Switch

※ Please contact us for the details of option D, G, H and Q.

### 9 Unit of Pressure Gauge

- Blank** : MPa (Standard)  
**N** : PSI (used only in USA)/ NPT-Thread Fitting  
**P** : PSI (used only in USA)/ Rc-Thread Fitting

Clamp  
 Hydraulic Unit  
 Operation Control Panel

Die Lifter  
 Pre-Roller

Accessories

Cautions  
 Company Profile

Clamp

GA  
 GD  
 GB  
 GE  
 GP  
 GN

Hydraulic Unit

CP  
 CR  
 CS

Pump Unit

CB  
 CD  
 CC

Valve Unit

BC  
 BH  
 MV

Operational Control Panel

YP  
 YA

**● Circuit Symbol / Main Circuit Examples** ※Please contact us for other circuits.

Circuit Symbol	Circuit Type (for reference)	Number of Circuits	BA Valve Number of Connection	Air Solenoid Valve	Pressure Relief Valve	Pressure Switch
C	Clamp Circuit	1	1	Single Solenoid	—	○
CR		1	1	Single Solenoid	○	○
CC		2	2	Single Solenoid	—	○
CRCR		2	2	Single Solenoid	○	○
U		1	1	Double Solenoid	—	○
D	Die Lifter Circuit	1	1	Double Solenoid	—	○
V		1	1	Double Solenoid	—	○

**C** Clamp Circuit (Single Solenoid Valve)

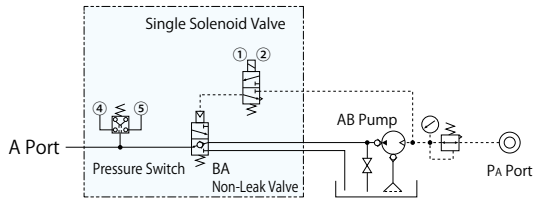

**D** Die Lifter Circuit (Single Solenoid Valve)

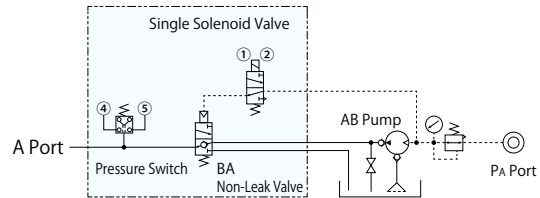

**U** Clamp Circuit (Double Solenoid Valve)

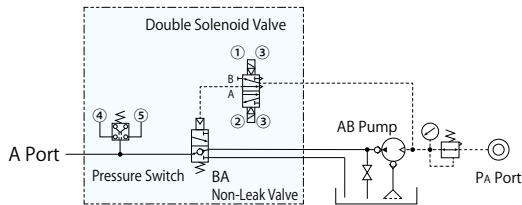

**V** Die Lifter Circuit (Double Solenoid Valve)

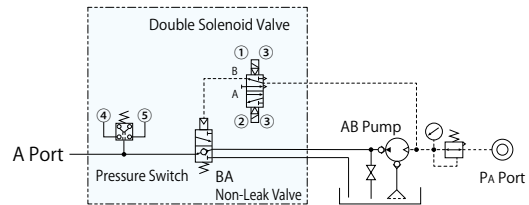

**● External Dimensions : CP20M1 / CP20N1**

※The drawing is for 2 liter tank.

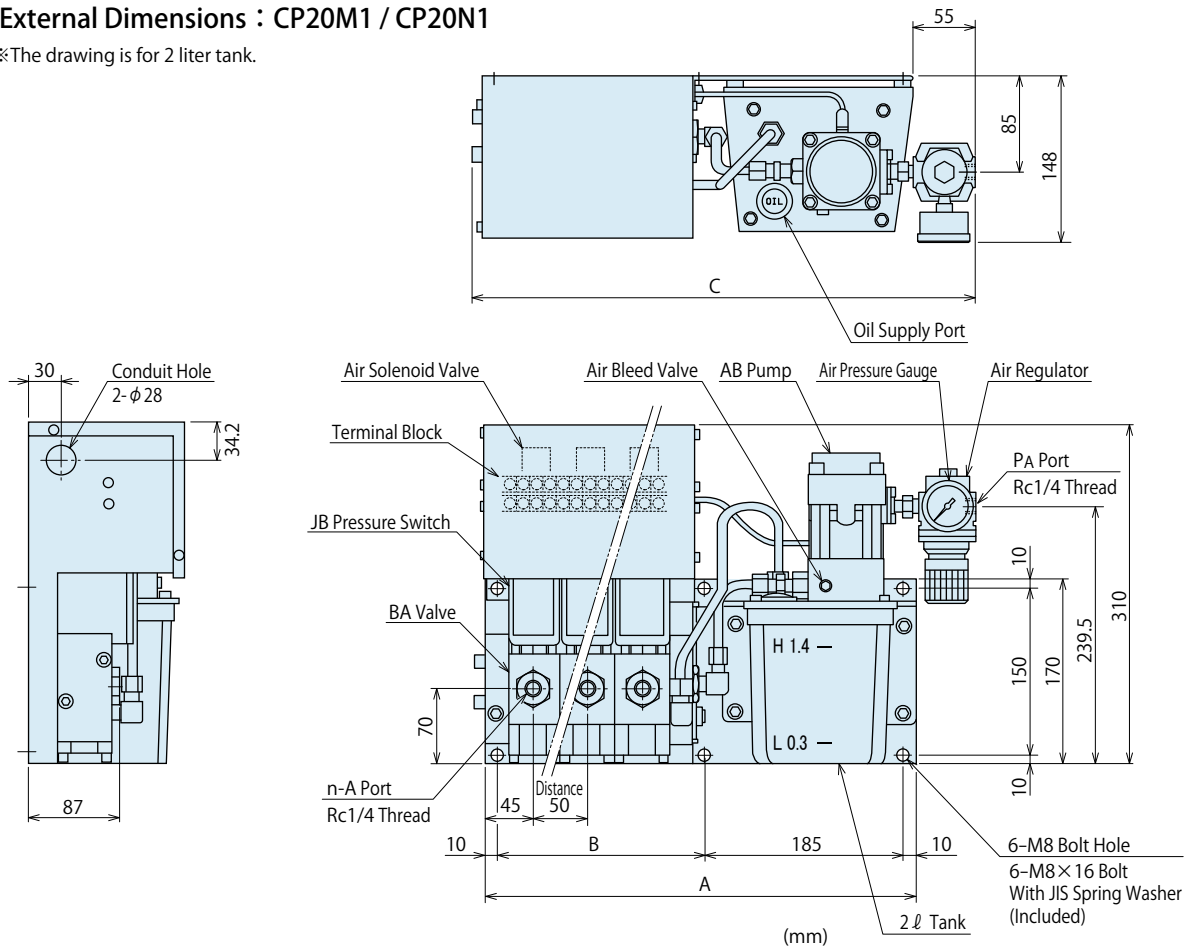

Valve Number of Connection (n)	1 Connection	2 Connections	3 Connections	4 Connections
A	295	345	395	445
B	90	140	190	240
C	359	409	459	510

Note

1. Please contact us for the specification (water-glycol type, with filter regulator, with hydraulic pressure switch, with piping block, with oil level switch) other than the drawing above.

**External Dimensions : CP50M1 / CP50N1**

※The drawing is for 5 liter tank.

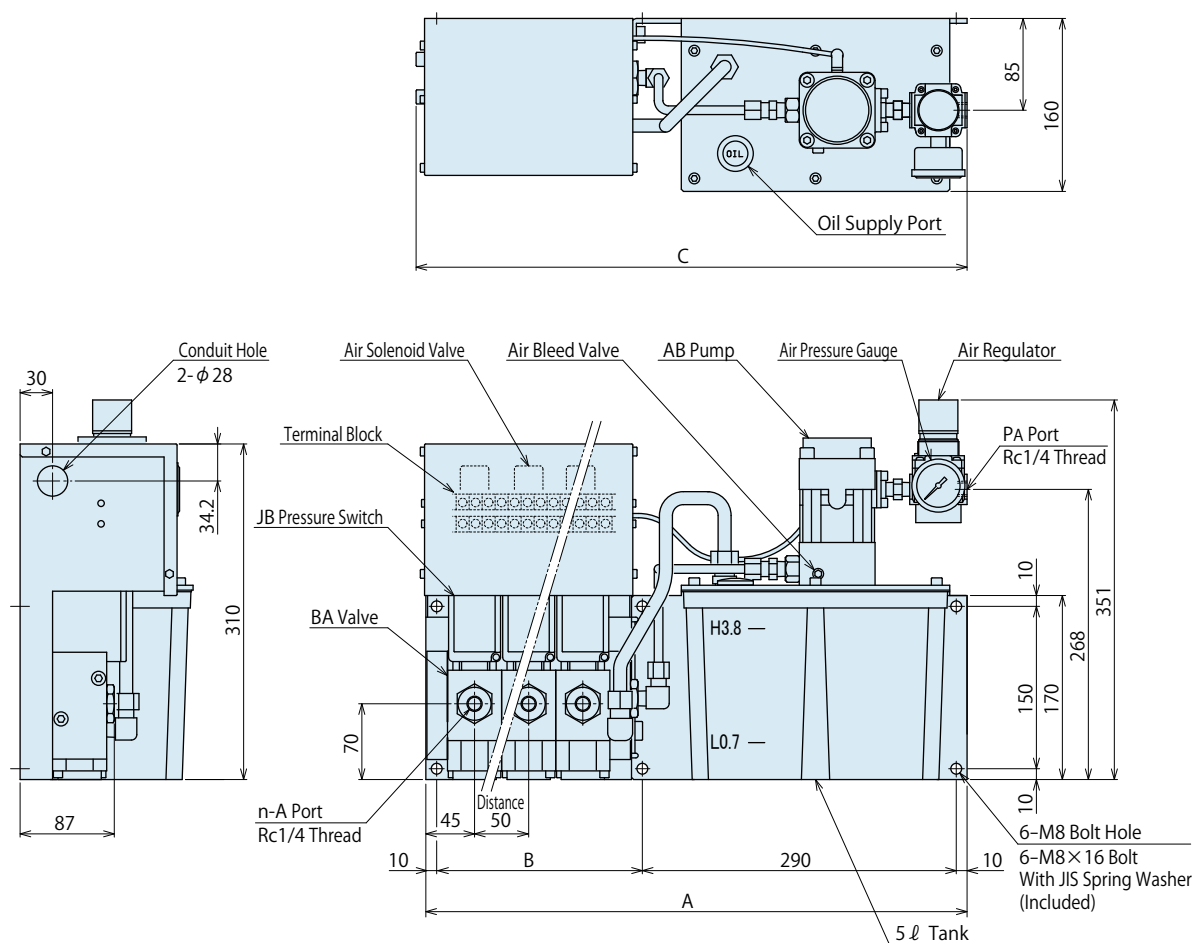

(mm)				
Valve Number of Connection (n)	1 Connection	2 Connections	3 Connections	4 Connections
A	400	450	500	550
B	90	140	190	240
C	409	459	509	560

**Note**

1. Please contact us for the specification (water-glycol type, with filter regulator, with hydraulic pressure switch, with piping block, with oil level switch) other than the drawing above.

- Clamp
- Hydraulic Unit
- Operation Control Panel
- Die Lifter
- Pre-Roller
- Accessories
- Cautions
- Company Profile

Clamp

- GA
- GD
- GB
- GE
- GP
- GN

Hydraulic Unit

- CP
- CR
- CS

Pump Unit

- CB
- CD
- CC

Valve Unit

- BC
- BH
- MV

Operational Control Panel

- YP
- YA

## External Dimensions : CR5M31 / CR5N31

※The drawing is for 5 liter tank.

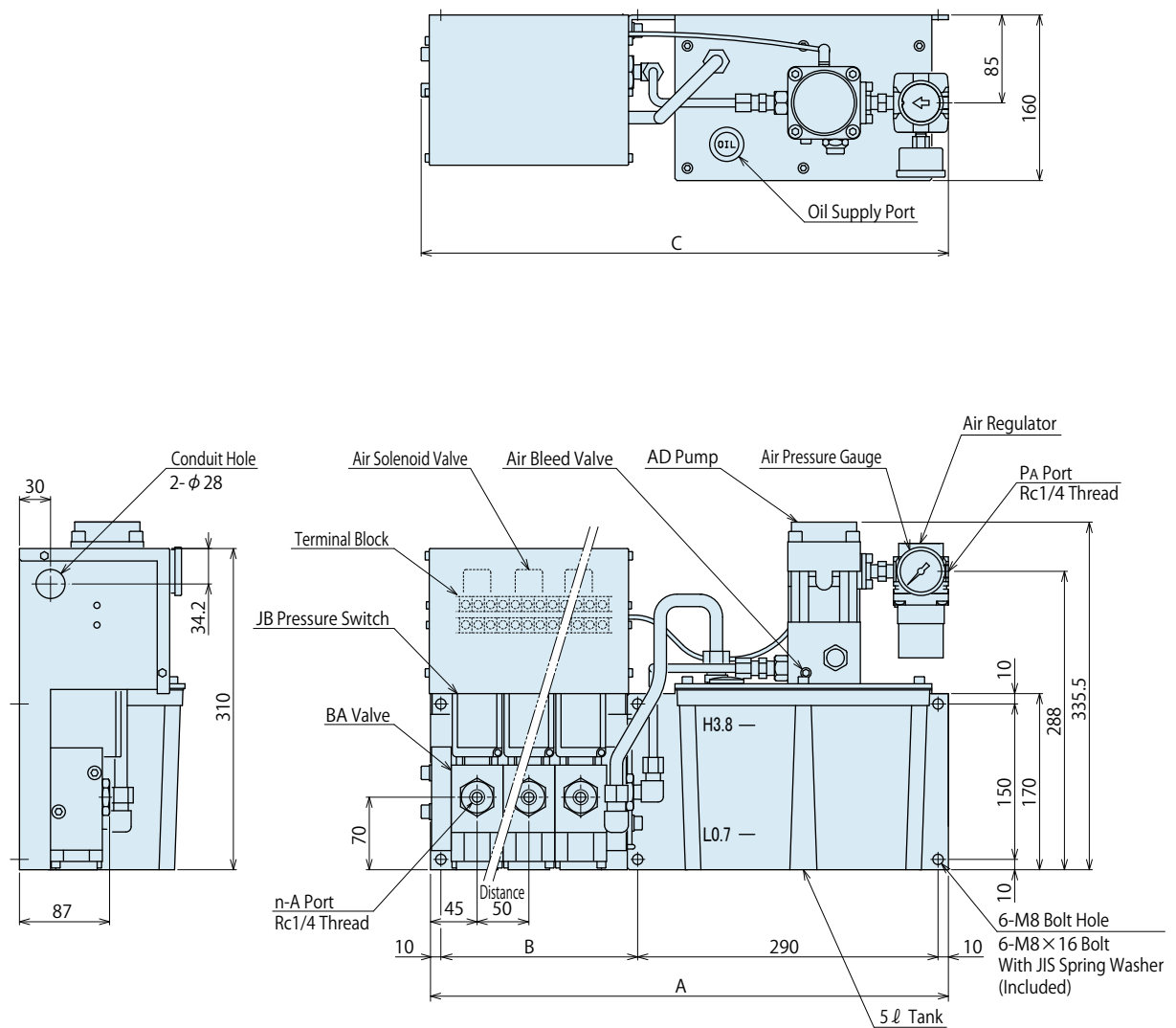

(mm)

Valve Number of Connection (n)	1 Connection	2 Connections	3 Connections	4 Connections
A	400	450	500	550
B	90	140	190	240
C	409	459	509	560

### Note

1. Please contact us for the specification (2 l tank, water-glycol type, with filter regulator, with hydraulic pressure switch, with piping block, with oil level switch) other than the drawing above.

External Dimensions : CS50M0 / CS50N0

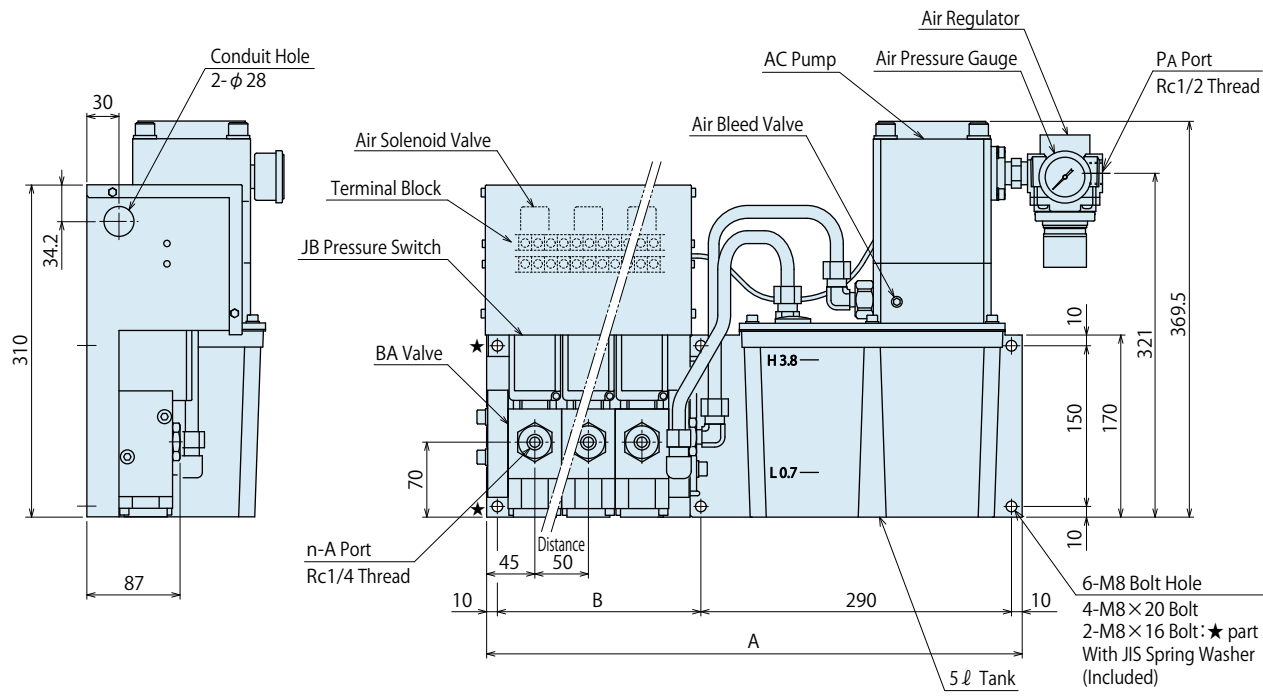
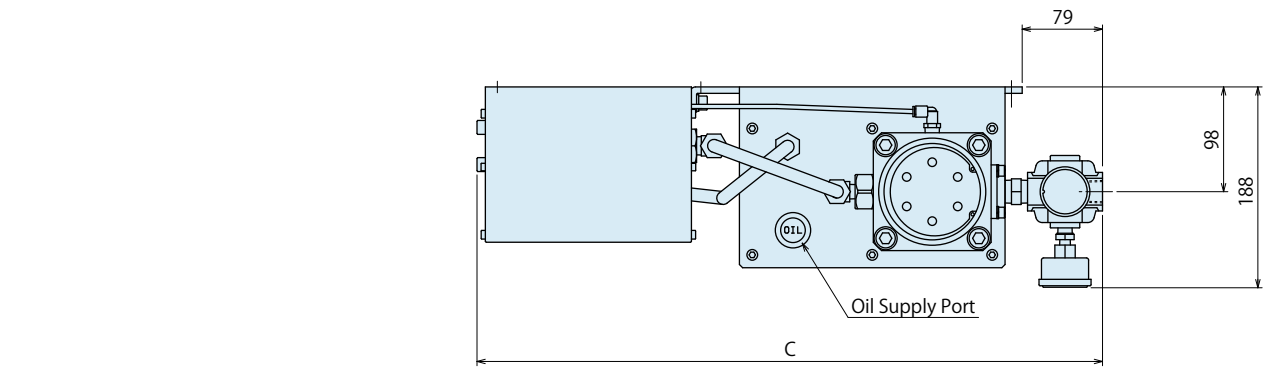

(mm)

Valve Number of Connection (n)	1 Connection	2 Connections	3 Connections	4 Connections
A	400	450	500	550
B	90	140	190	240
C	486	536	586	637

**Note**  
1. Please contact us for the specification (water-glycol type, with filter regulator, with hydraulic pressure switch, with piping block, with oil level switch) other than the drawing above.

**Clamp Hydraulic Unit Operation Control Panel**

Die Lifter Pre-Roller

Accessories

Cautions Company Profile

---

Clamp

- GA
- GD
- GB
- GE
- GP
- GN

---

**Hydraulic Unit**

- CP
- CR
- CS

---

Pump Unit

- CB
- CD
- CC

---

Valve Unit

- BC
- BH
- MV

---

Operational Control Panel

- YP
- YA

## ● Cautions

### ● Notes on Installation (Cautions for Hydraulic Series)

#### 1) Check the fluid to use

- Please use the appropriate fluid by referring to the Hydraulic Fluid List.
- If hydraulic oil with viscosity grade higher than ISO-VG-32 is used, action time would be longer.
- If using it at low temperature, action time will be longer because the viscosity of hydraulic oil becomes higher.

#### 2) Procedure before piping

- The pipeline, piping connector and fixture circuits should be cleaned by thorough flushing.
- The dust and cutting chips in the circuit may lead to fluid leakage and malfunction.
- Our products except some valves are not equipped with protective function to prevent dust and cutting chips going into the hydraulic system and pipeline.

#### 3) Applying sealing tape

- Wrap with tape 1 to 2 times following the screwing direction.
- Pieces of the sealing tape can lead to air leaks and malfunction.
- In order to prevent a foreign substance from going into the product during piping, it should be carefully cleaned.

#### 4) Air bleeding in the hydraulic circuit

- If the hydraulic circuit has excessive air, the action time may become very long.  
After installing the hydraulic circuit, or if the pump run out of oil, be sure to bleed air by the following step.
- ① Reduce hydraulic supply pressure to less than 2MPa.
- ② Please loosen the cap nut of pipe fitting that is closest to clamps · RA die lifters by one full turn.
- ③ Wiggle the pipeline to loosen the outlet of pipeline fitting.  
The hydraulic fluid mixed with air comes out.

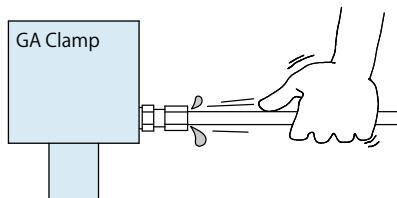

- ④ Tighten the cap nut after bleeding.
- ⑤ It is more effective to bleed air at the highest point inside the circuit or at the end of the circuit.

#### 5) Checking looseness and retightening

- At the beginning of the machine installation, the bolt/nut may be tightened lightly.  
Check torque and re-tighten as required.

### ● Hydraulic Fluid List

Maker	ISO Viscosity Grade ISO-VG-32	
	Anti-Wear Hydraulic Oil	Multi-Purpose Hydraulic Oil
Showa Shell Sekiyu	Tellus S2 M 32	Morlina S2 B 32
Idemitsu Kosan	Daphne Hydraulic Fluid 32	Daphne Super Multi Oil 32
JX Nippon Oil & Energy	Super Hyrando 32	Super Mulpus DX 32
Cosmo Oil	Cosmo Hydro AW32	Cosmo New Mighty Super 32
ExxonMobil	Mobil DTE 24	Mobil DTE 24 Light
Matsumura Oil	Hydol AW-32	
Castrol	Hyspin AWS 32	

Note As it may be difficult to purchase the products as shown in the table from overseas, please contact the respective manufacturer.

## ● Speed Control Circuit of Hydraulic Cylinder and Notes



If the hydraulic cylinder speed is controlled, the circuit should be designed with the following points taken into consideration. Review these notes prior to installation as the wrong circuit design may lead to machine malfunction and damage.

### ● Flow control circuit for single acting cylinder.

For spring return type single acting cylinders, restricting flow during release can extremely slow down or prevent release action. The preferred method is to control the flow during the lock action and use a valve that has free-flow in the release direction. Also, it is preferred to provide a flow control valve at each actuator.

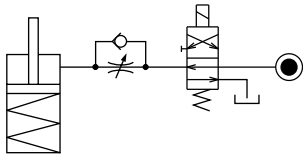

If the release action is accelerated by excessive hydraulic flow the cylinder may sustain damage. In this case add flow control to regulate flow.

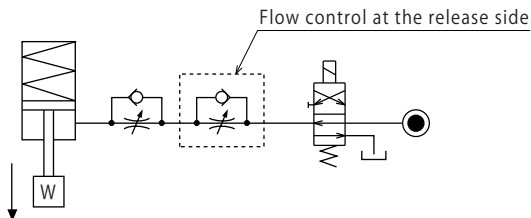

### ● Flow control circuit for double acting cylinder.

Flow control circuit for double acting cylinder should have meter-out circuits for both the lock and release sides. Meter-in control can have adverse effect by presence of air in the system.

#### 【Meter-out circuit】

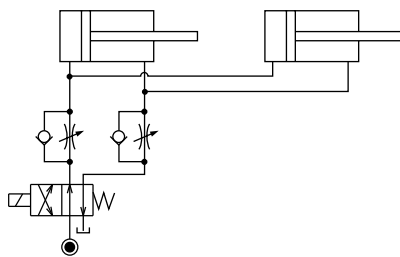

#### 【Meter-in circuit】

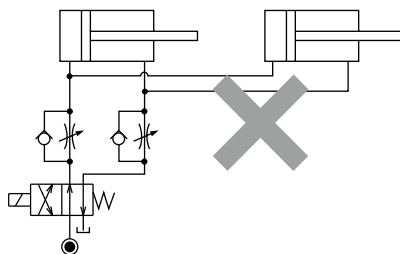

In the case of meter-out circuit, the hydraulic circuit should be designed with the following points.

- ① Single acting components should not be used in the same flow control circuit as the double acting components. The release action of the single acting cylinders may become erratic or very slow.

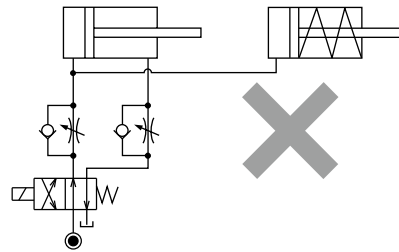

Refer to the following circuit when both the single acting cylinder and double acting cylinder are used together.

- Separate the control circuit.

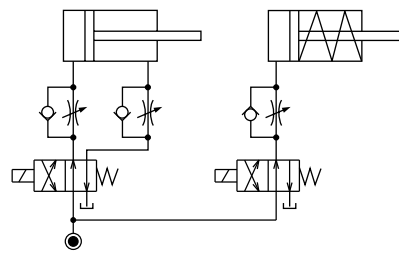

- Reduce the influence of double acting cylinder control unit. However, due to the back pressure in tank line, single action cylinder is activated after double action cylinder work.

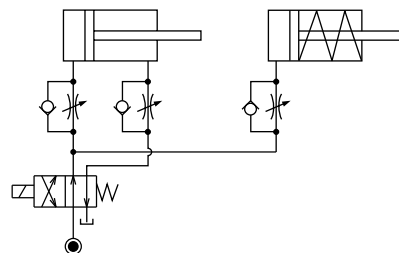

- ② In the case of meter-out circuit, the inner circuit pressure may increase during the cylinder action because of the fluid supply. The increase of the inner circuit pressure can be prevented by reducing the supplied fluid beforehand via the flow control valve. Especially when using sequence valve or pressure switches for clamping detection, if the back pressure is more than the set pressure then the system will not work as it is.

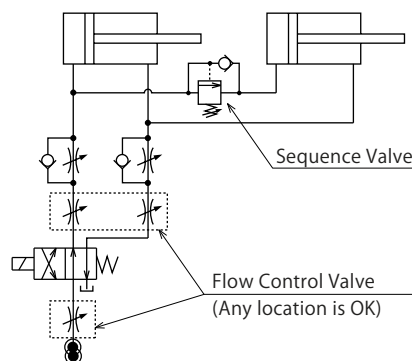



## ● Cautions

### ● Notes on Handling

- 1) It should be handled by qualified personnel.
  - The hydraulic machine / air compressor should be handled and maintained by qualified personnel.
- 2) Do not handle or remove the machine unless the safety is ensured.
  - ① The machine and equipment can only be inspected or prepared when it is confirmed that the preventive devices are in place.
  - ② Before the machine is removed, make sure that the above-mentioned safety measures are in place. Shut off the air of hydraulic source and make sure no pressure exists in the hydraulic and air circuit.
  - ③ After stopping the machine, do not remove until the temperature cools down.
  - ④ Make sure there is no abnormality in the bolts and respective parts before restarting the machine or equipment.
- 3) Do not touch clamps (cylinders) while they are working. Otherwise, your hands may be injured.

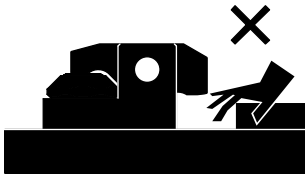

- 4) Do not disassemble or modify it.
  - If the equipment is taken apart or modified, the warranty will be void even within the warranty period.

### ● Maintenance • Inspection

- 1) Removal of the machine and shut-off of pressure source
  - Before the machine is removed, make sure that the above-mentioned safety measures are in place. Shut off the air of hydraulic source and make sure no pressure exists in the hydraulic and air circuit.
  - Make sure there is no abnormality in the bolts and respective parts before restarting.
- 2) Regularly clean the area around the equipment.
  - If it is used when the surface is contaminated with dirt, it may lead to packing seal damage, malfunctioning, fluid leakage and air leaks.

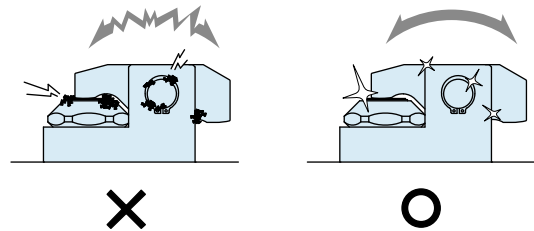

- 3) If disconnecting by couplers on a regular basis, air bleeding should be carried out daily to avoid air mixed in the circuit.
- 4) Regularly tighten bolts and pipe line, mounting bolts, nuts, circlips and cylinders to ensure proper use.
- 5) Make sure the hydraulic fluid has not deteriorated.
- 6) Make sure there is smooth action and no abnormal noise.
  - Especially when it is restarted after left unused for a long period, make sure it can be operated properly.
- 7) The products should be stored in the cool and dark place without direct sunshine or moisture.
- 8) Please contact us for overhaul and repair.

## ● Warranty

### 1) Warranty period

- The product warranty period is 18 months from shipment from our factory or 12 months from initial use, whichever is earlier.

### 2) Warranty scope

- If the product is damaged or malfunctions during the warranty period due to faulty design, materials or workmanship, we will replace or repair the defective part at our expense. Defects or failures caused by the following are not covered.

- ① If the stipulated maintenance and inspection are not carried out.
- ② If the product is used while it is not suitable for use based on operator judgment, resulting in defect.
- ③ If it is used or handled in inappropriate way by the operator. (Including damage caused by the misconduct of a third party.)
- ④ If the defect is caused by reasons other than our responsibility.
- ⑤ If repair or modifications are carried out by anyone other than Kosmek, or without our approval and confirmation, it will void warranty.
- ⑥ Defects caused by natural disasters or calamities not attributable to our company.
- ⑦ Parts expenses or replacement expenses due to parts consumption and deterioration. (Such as rubber, plastic, seal material and some electric components.)

Damages from direct result of a product defect shall be excluded from the warranty.

Clamp  
Hydraulic Unit  
Operation Control Panel

Die Lifter  
Pre-Roller

Accessories

Cautions  
Company Profile

#### Cautions

Notes on Installation  
(For Hydraulic Series)

Hydraulic Fluid List

Speed Control Circuit of  
Hydraulic Cylinder & Notes

Notes on Handling

Maintenance / Inspection

Warranty

#### Company Profile

Company Profile

Our Products

History

Sales Office

# Sales Office

## Sales Offices Across the World

Japan Overseas Sales	<b>TEL. +81-78-991-5162</b>	<b>FAX. +81-78-991-8787</b>
	KOSMEK LTD. 1-5, 2-chome, Murotani, Nishi-ku, Kobe-city, Hyogo, 651-2241, Japan 〒651-2241 兵庫県神戸市西区室谷2丁目1番5号	
USA KOSMEK (USA) LTD.	<b>TEL. +1-630-241-3465</b>	<b>FAX. +1-630-241-3834</b>
	1441 Branding Avenue, Suite 110, Downers Grove, IL 60515 USA	
China KOSMEK (CHINA) LTD. 考世美(上海)貿易有限公司	<b>TEL. +86-21-54253000</b>	<b>FAX. +86-21-54253709</b>
	21/F, Orient International Technology Building, No.58, Xiangchen Rd, Pudong Shanghai 200122., P.R.China 中国上海市浦东新区向城路58号东方国际科技大厦21F室 200122	
Thailand Thailand Representative Office	<b>TEL. +66-2-715-3450</b>	<b>FAX. +66-2-715-3453</b>
	67 Soi 58, RAMA 9 Rd., Suanluang, Suanluang, Bangkok 10250, Thailand	
Europe (Europe Exclusive Distributors) KOS-MECH GmbH	<b>TEL. +43-463-287587-10</b>	<b>FAX. +43-463-287587-20</b>
	Schleppeplatz 2 9020 Klagenfurt Austria	
Taiwan (Taiwan Exclusive Distributors) Full Life Trading Co., Ltd. 盈生貿易有限公司	<b>TEL. +886-2-82261860</b>	<b>FAX. +886-2-82261890</b>
	16F-4, No.2, Jian Ba Rd., Zhonghe District, New Taipei City Taiwan 23511 台湾新北市中和區建八路2號 16F-4 (遠東世紀廣場)	
Philippines (Philippines Exclusive Distributors) G.E.T. Inc, Phil.	<b>TEL.+63-2-310-7286</b>	<b>FAX. +63-2-310-7286</b>
	Victoria Wave Special Economic Zone Mt. Apo Building, Brgy. 186, North Caloocan City, Metro Manila, Philippines 1427	
Indonesia (Indonesia Exclusive Distributors) P.T PANDU HYDRO PNEUMATICS	<b>TEL.+62-21-5818632</b>	<b>FAX. +62-21-5814857</b>
	Ruko Green Garden Blok Z- II No.51 Rt.005 Rw.008 Kedoya Utara-Kebon Jeruk Jakarta Barat 11520 Indonesia	

## Sales Offices in Japan

Head Office Kansai Office Overseas Sales	<b>TEL. +81-78-991-5162</b>	<b>FAX. +81-78-991-8787</b>
	KOSMEK LTD. 1-5, 2-chome, Murotani, Nishi-ku, Kobe-city, Hyogo, 651-2241, Japan 〒651-2241 兵庫県神戸市西区室谷2丁目1番5号	
Kanto Office	<b>TEL. +81-48-652-8839</b>	<b>FAX. +81-48-652-8828</b>
	KOSMEK LTD. 81, 4-chome, Onari-cho, Kita-ku, Saitama City, Saitama, 331-0815, Japan 〒331-0815 埼玉県さいたま市北区大成町4丁目81番地	
Chubu Office	<b>TEL. +81-566-74-8778</b>	<b>FAX. +81-566-74-8808</b>
	KOSMEK LTD. 10-1, 2-chome, Misono-cho, Anjo City, Aichi, 446-0076, Japan 〒446-0076 愛知県安城市美園町2丁目10番地1	
Kyusyu Office	<b>TEL. +81-92-433-0424</b>	<b>FAX. +81-92-433-0426</b>
	KOSMEK LTD. 8-10-101, 1-chome, Kamimuta, Hakata-ku, Fukuoka City, Fukuoka, 812-0006, Japan 〒812-0006 福岡県福岡市博多区上牟田1丁目8-10-101	