



Industrial motor controller for brushed DC motors 24 VDC

Design for output currents up to 5 A

Control with the following functions:

- reversal of direction of rotation
- open-loop speed control (external)
- current limitation control (external)
- overcurrent limitation / overcurrent shutdown
- adjustable start ramp (external)
- adjustable current monitoring delay
- IxR compensation
- short circuit detection
- dynamic brake

To snap onto the DIN rail
EN 50022

Unit width: 22,5 mm

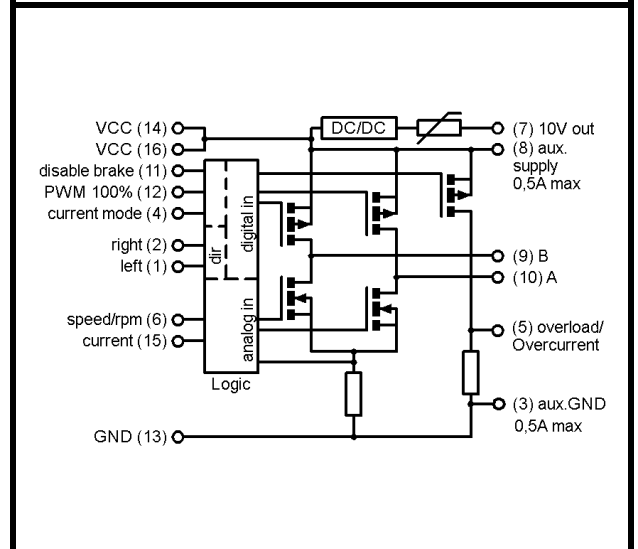

Type	M3-4Q-5-30	
Article number	06.34.002	
Operating data		
Nominal voltage	U_{nom}	24,0 VDC
Supply voltage	V_{CC}	18 .. 30 VDC
Control inputs	U_{DI}	24,0 VDC
Analog input	U_{AI}	0 .. 10 VDC
Quiescent current typ	I_0	50 mA
Technical data: load circuit		
Max. current / continuous load current	I_{max}/I_{con}	15 / 5 A
Short circuit current detection typ	I_{SC}	80 A
Shut-down time after short circuit typ	t_{sc}	100 μ s
PWM frequency	F_S	15,6 kHz
Duty cycle trimmer TR4 (PWM)		5 .. 100 %
Power stage driver		MOS-FET
Other data		
Dimensions	22,5 x 70,4 x 85,0 mm	
Connectors	push-in terminal, pitch 5 mm cross section 0,2 – 2,5 mm ²	
Permissible ambient temperature	T_{amb}	-20 .. +50 °C
Temperature monitoring / overvoltage protection	yes / yes	
Status indication: overcurrent / status	LED1 red / LED2 green	

Other data	
Start ramp trimmer TR3 (start-ramp)	0 .. 4 s
Disable Time trimmer TR2 (CM-delay)	0 .. 1 s
Currentlimitation adjustable over DIP	0,5 .. 5A
IxR compensation trimmer TR1 (IxR)	R _I 0 .. 2,1 Ω
Dynamic brake (Armature short circuit)	Can be switched off
Installation orientation / Assembly	any / top-hat rail EN 50022
Installation place, typical	Switch cabinet
Storage temperature	-30 .. +85 °C
Permissible humidity	0 to 95 %, non-condensing
Weight	0,075 kg
Start up time	2 s
MTBF (SN29500, 40°C, rated load)	85,7 years
Hazardous substance norm	RoHS2
EMC interference immunity	EN 61326-1:2013-01 EN 61000-6-2:2005-08
EMC emitted interference, operation in industrial DC network	EN 61326-1:2013-01, Class A
EMC emitted interference, operation with power supply	EN 61326-1:2013-01, Class B
supply unit / power unit	KDR 120-24, Ott GmbH & Co. KG or comparable

Technical data: digital input	
High Signal typ.	U > 10 V
Low Signal typ.	U < 4 V
Impedance typ.	R _{DI} 15 kΩ

Technical data: digital output overcurrent	
„Ready“	GND (4,7kΩ Pull-Down)
„Overcurrent“	VCC
Current typ	IDO 700 mA
Short circuit-proof	Yes, self-limiting

Technical data: analog input	
Voltage range	0 .. 10 V
V _{cc} tolerant	yes
Impedance typical	R _{AI} 98,5 kΩ

Flammability	
Housing, terminals, printed circuit board	UL94V-0

Starting behavior
 After applying supply voltage, the module M3-4Q-5-30 is ready for operation when the start up time has elapsed.

Description
 The M3-4Q-5-30 module is a multi-functional motor controller for use in industrial environments. It ensures the switching on and off, as well as the controlled driving of motors. The motor's direction of rotation can be set via a digital input. An internal trimmer can be used to set the maximum speed. By means of an analog input the speed can be set between 0 to maximum speed. The dynamic brake can be deactivated over a digital input. The module has an adjustable starting ramp and current monitoring delay. The IxR compensation can be used to minimize load-dependent speed changes. The maximum motor current can be set by DIP switches. Additionally the motor current can be reduced through an analog input during operation. A digital input allows to switch between the functions overcurrent shut-off and current limitation. By means of a further digital input, the module can be switched to 100% PWM speed.

Typical application: Standard

Typical application: PLC

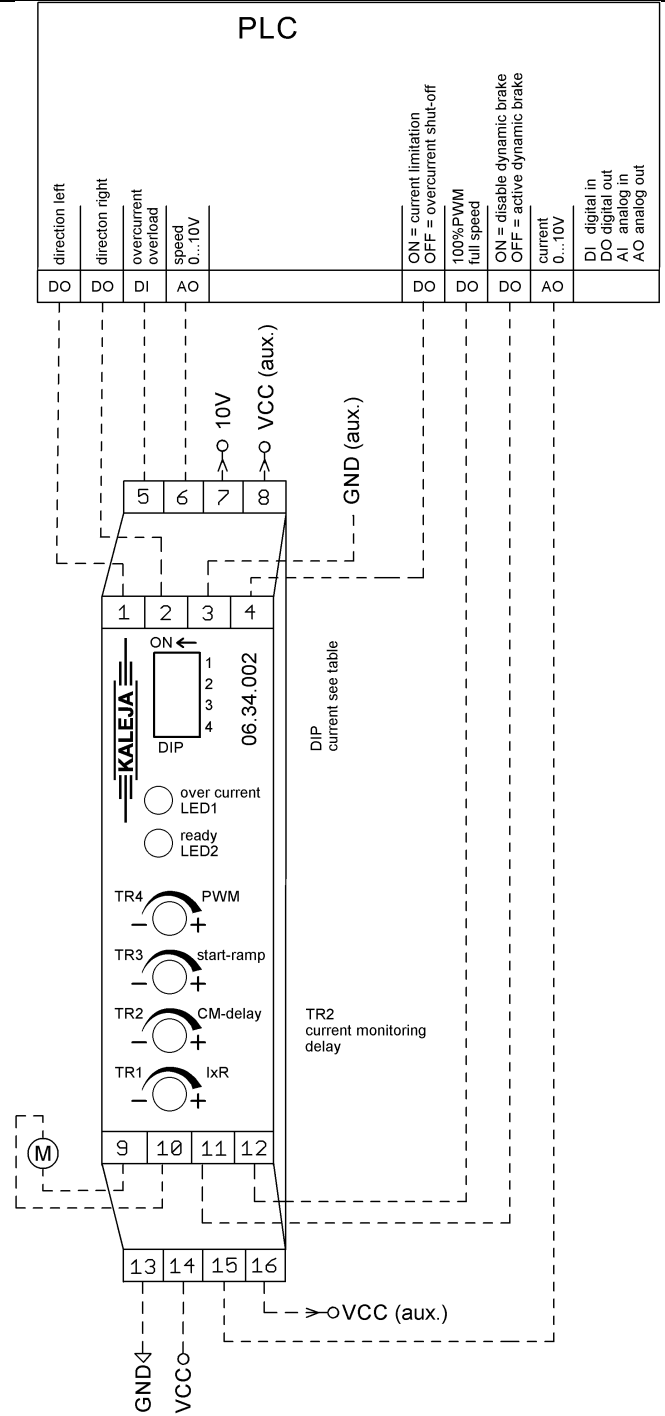
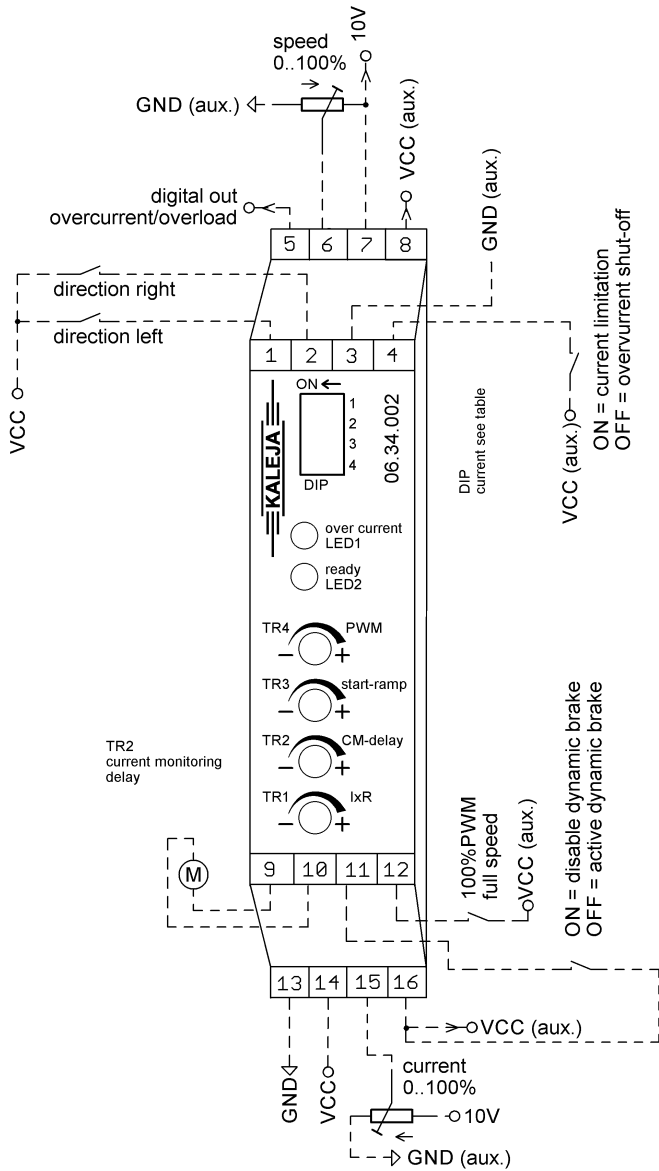

Terminal diagram

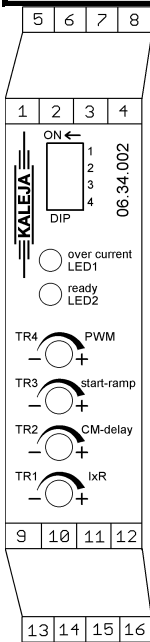

5 digital output „overcurrent“ High-aktiv	6 analog input 0...10 V, „rotation speed“	7 Auxiliary voltage output +10V (PTC-Fuse) for 2 x 10kOhm potentiometer	8 Auxiliary voltage output +24 V 0,5 A max
1 digital input „direction left“ (p- switch)	2 digital input „direction right“ (p- switch)	3 GND for external potentiometer 0,5 A max	4 digital input „current limitation/overcurrent shutdown“ (p- switch)
9 Motor winding B	10 Motor winding A	11 digital input „disable dynamic brake“ (p- switch)	12 digital input „100 % PWM“ (p- switch)
13 GND supply	14 +24 V supply +/-10 %	15 analog input 0..10 V „current limit“	16 Auxiliary voltage output +24 V

State table

direction „left“ (1)	direction „right“ (2)	disable dyn. braking (11)	Motor „A“ (10)	Motor „B“ (9)	Funktion
0	1	X	VCC	GND	run right
1	0	X	GND	VCC	run left
1	1	X	GND	GND	dyn. braking
0	0	0	GND	GND	dyn. braking
0	0	1	open	open	off

0 = off 1 = on x = don't care

Function: Rotation speed control

The maximum output speed can be set or limited with the trimmer TR4.
 The speed setting itself is given through the analog input voltage at terminal (6) in the range of 0 to 100% adjustable via trimmer TR4.
 An analog voltage must be applied at terminal (6) in order to turn the motor. 0 V at terminal (6) equals to 0 rpm.
 If the module should operate only with the internal set speed, terminal (6) must be connected to + 10V / VCC, e.g. connect terminal (6) to terminal (7).

Function: PWM100%

If applying a HIGH signal at terminal (12), the motor output will be directly set to 100% PWM (speed). Regardless of any setting at TR4 or analog input at terminal (6).

- In case of a running motor. The ramp up function is not active. The current monitoring delay is started, so the current monitoring is not active for that time.
- If a HIGH signal at terminal (12) is set before setting the direction. The module ramps up with the adjusted ramp time on trimmer TR3 to 100% PWM (speed).

Function: dynamic brake	Function: short circuit detection
-------------------------	-----------------------------------

The module stops the motor with “dynamic brake” function by default. It can be deactivated by applying a HIGH signal at terminal (11).
 If dynamic braking is active, the motor winding is switched to GND at both terminals when switched off.
 The motor is stopped with armature short circuit braking.
 If dynamic braking is not active, the motor stops with no braking.
 If both rotation direction inputs (terminals 1 and 2) are simultaneously high, the motor always stops with a dynamic brake. In this case the brake setting at the digital input (11).

When the module detects a short circuit on the motor output, the motor switches off without dynamic braking. The motor can be restarted by means of a reset and fresh setting of any input of direction of rotation.

Function: overcurrent shut-off / current limitation	Function: setting the maximum motor current
---	---

The module can be operated in overcurrent shut-off or current limitation mode. The mode is given by the digital input at terminal (4):
overcurrent shutdown:
 If the digital input is not active (not connected), the module is in the overcurrent shut-off mode. If the motor current exceeds the adjusted maximum motor current, the module turns off the motor. The motor can be restarted by resetting any of the two inputs of direction of rotation.
current limitation:
 When the digital input is applied with HIGH signal, the module is in current limitation mode. In this mode, the motor current is limited to the adjusted maximum value.

The maximum motor current is adjusted via the DIP switch on the module and the analog input on terminal (15).
 The maximum permissible motor current is set via the DIP switches 1-4 (see table). The motor current itself is then given by the applied voltage at analog input on terminal (15), in the range from 0 to 100% of the preset value.
 If the module should be operated only with the maximum motor current setting of the DIP switches, the terminal 15 must be connected to +10V or to VCC, (e.g. bridge terminal (15) with terminal (16) or (7)).

DIP1	DIP2	DIP3	DIP4	Max. current [A]
Off	Off	Off	Off	0,5
On	Off	Off	Off	0,75
Off	On	Off	Off	1
On	On	Off	Off	1,25
Off	Off	On	Off	1,5
On	Off	On	Off	1,75
Off	On	On	Off	2
On	On	On	Off	2,25
Off	Off	Off	On	2,5
On	Off	Off	On	2,75
Off	On	Off	On	3
On	On	Off	On	3,25
Off	Off	On	On	3,5
On	Off	On	On	4
Off	On	On	On	4,5
On	On	On	On	5

Function: Start ramp	Function: IxR compensation
----------------------	----------------------------

After setting any direction of rotation, the module ramps up the speed until the set value is reached. The gradient of the start ramp can be adjusted via trimmer TR3.

The module has a built in IxR compensation function. This function can be used to compensate load depending speed changes of the motor. The gain factor is set with trimmer TR1.
**!ATTENTION! Please use this function carefully!
 Incorrect gain factors may cause instable operation!**

Function: current monitoring delay	Function: Overcurrent output
------------------------------------	------------------------------

The current monitoring delay is adjustable by trimmer TR2. After setting any direction of rotation input the overcurrent shutdown is disabled for the adjusted time. The current monitoring delay is also started when setting the PWM100% digital input on terminal (12) to HIGH signal.

The overcurrent output indicates by a HIGH signal:

In current limitation mode:
As long as the motor current is limited.

In overcurrent shut-off mode
As soon as over current is detected and motor is stopped.

Device status	Display elements
---------------	------------------

The module status is displayed via the LEDs on the module front plate.

Module errors are displayed as flashing sequences. The end of the sequence is indicated by a pause of 1 second. The number of flashes indicates the error number.

LED1 red	LED2 green	meaning
Off	On	Module is operational
On	flashing	overcurrent shut-off active and overcurrent detected
On	On	Current limitation active and overcurrent detected
On/Off	flashing	Module error 1 (see table)
flashing	flashing	Internal Error

Module error 1

1	overcurrent
2	Over-temperature
3	short circuit detected
4	overvoltage
5	overload
6	Under-temperature
7	Low supply voltage
8	

Dimensional drawing

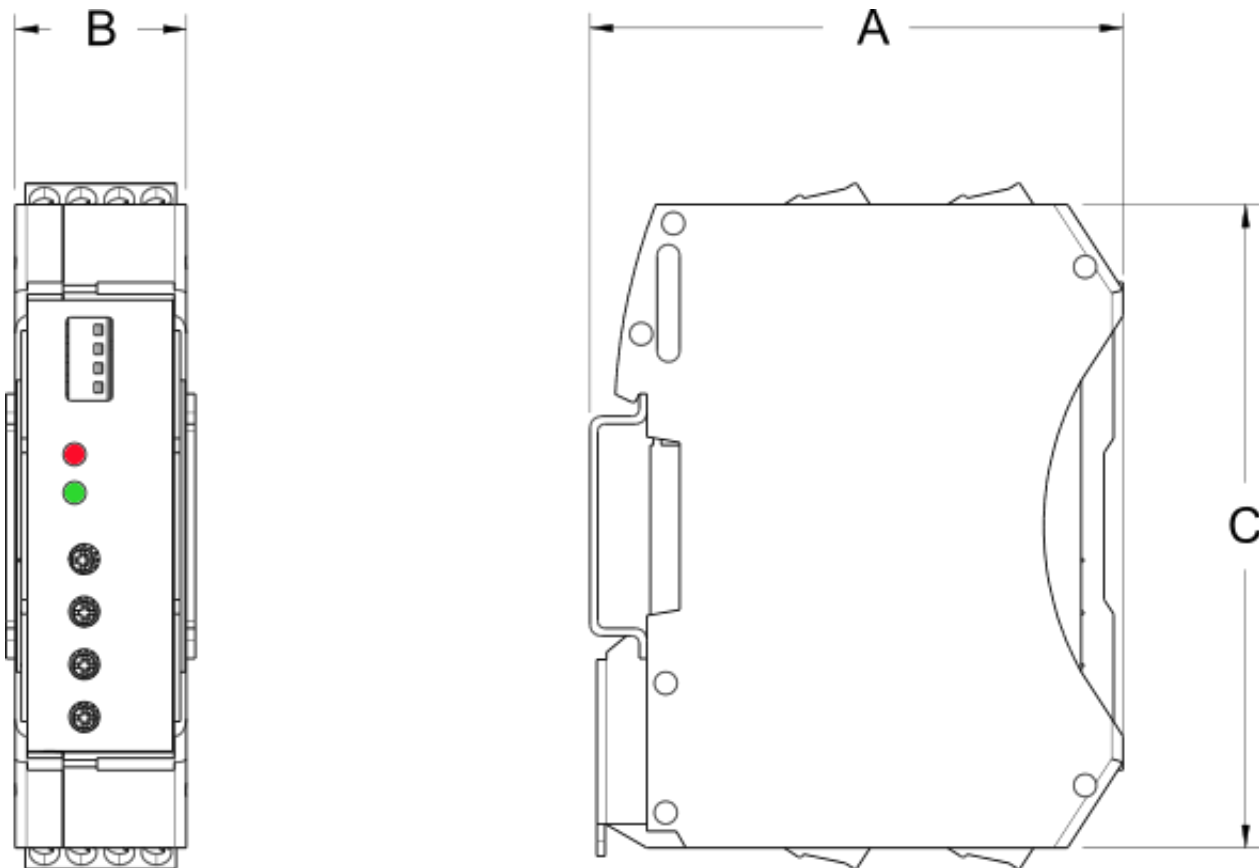

A = 70,4 mm; B = 22,5 mm; C = 85 mm

Safety notes

Maximum operational data

The maximum operating data must not be exceeded.

Installation

The installation and start-up must be performed by specialist personnel exclusively.

All affected components must be disconnected from the mains.

Start-up

For the first start-up, the motor should be operated without load.

Risk of death

Do not touch live parts after switching on!

The assembly must be operated exclusively on safety extra-low voltage. With operation on extra-low voltage (e.g. via autotransformer), death or injury can occur.

Fire protection

The assembly must be installed in a switch cabinet, which is suitable as a fire protection enclosure.

The assembly must be safeguarded with a pre-fuse aligned with the nominal data.

Field of application

The assembly may only be used as intended.

Other components must be checked for their approvals and regulations.

Safety devices

An additional safety device must be used to bring the system into a safe state in case of a cable break, incorrect operation, failure of the control/controller unit.

EMC / EMI

The wiring must be done according to EMC / EMI standards. If necessary, shielded cables and EMC suppressors must be used for the connected consumer.

For operation in a public low-voltage distribution network, the module must be supplied with an approved AC adapter.

If the module is supplied with an AC adapter, other equipment, operated on the same power supply, must be suitable for use in industrial environments.

Repairs

Repairs must be performed by authorised persons exclusively. With unauthorised opening, the warranty cover is voided and this may also result in danger for the user and for the system.

Maintenance

The assembly is wear-free by design.

For modules **with** cooling openings free air circulation must be checked at the cooling openings or on the housing at regular intervals. If necessary, the cooling holes / the housing must be cleaned.

Good ventilation must be ensured.

contact details



ready-to-use motor control solutions
electronics design & manufacturing

KALEJA GmbH

Strübelweg 14

73553 Alfdorf, Germany

Phone: +49 7172 93711 0

Fax: +49 7172 93711 90

E-Mail: info@kaleja.com

www.kaleja.com