

# CAM-POST FOUNDATION

Post-Processor Generator for 2-Axis Lathes & 3-Axis Mills

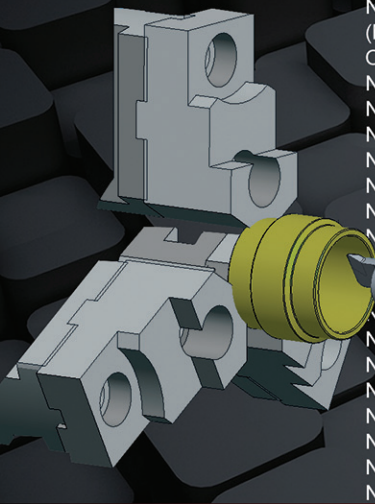

N94M01  
(MSG, ROUGH BORE I.D.)  
O95T12M06  
N96G94M42  
N97G01X8.Z17.F200.S260M03  
N98M42  
N99G00X3.261Z12.332S100M03  
N100Z11.482  
N101G95G01Z5.637F.018M08  
N102G00X3.086  
N103Z11.432  
N105G01Z11.432  
N106G00X3.216  
N107Z11.432  
N108X3.5433  
N109G01Z10.773  
N110X3.4719  
N111X3.381Z10.6156  
N112G00X3.206

N17 G17 T3 D3 M6 (1/4" BULLNOSE)  
N18 G0 X.1493 Y1.5356 Z1 S1500 M3  
N19 G1 X.1476 Y1.5767 Z.8625 F15  
N20 X.1348 Y1.6157 Z.8145  
N21 X.112 Y1.6498 Z.7843  
N22 X.0807 Y1.6764 Z.765  
N23 X.0434 Y1.6936 Z.7539  
N24 X.0028 Y1.7 Z.75  
N25 X0  
N26 X-3.2  
N27 Y1.05  
N28 X-3.03  
N29 G2 X-3.03 Y-1.05 CR=1.05  
N30 G1 X-3.2  
N31 Y-1.7  
N32 X3.2  
N33 Y-1.05  
N34 X2.98  
N35 G2 X2.98 Y1.05 CR=1.05  
N36 G1 X3.2

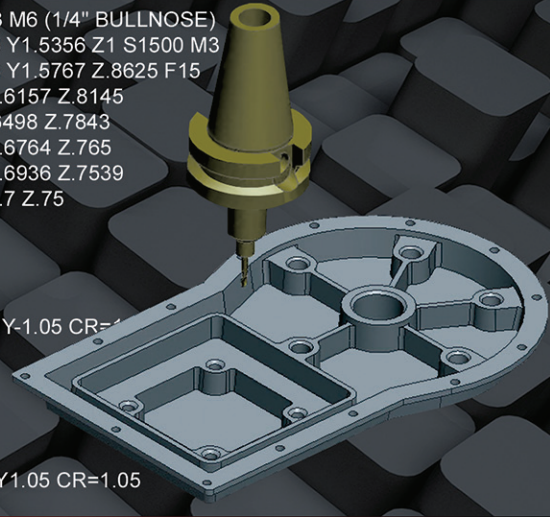

For all Popular CAD/CAM Systems, Machine Tools and Controls

CAM-POST Foundation is a fast and easy-to-use Post-processor Development Tool specifically designed to give you control over the development of post-processors for your 3 axis milling and 2 axis lathe machines. Incorporating over 40 years of industry leading CNC expertise and knowledge, CAM-POST Foundation places industry's most advanced, intuitive, and flexible post development technology at your fingertips.

## Why CAM-POST Foundation?

- Create unlimited 2-axis Lathe and 3-axis Mill post-processors for all machine tools & controls and for all popular CAD/CAM systems such as CATIA, NX and MasterCam
- Take Control and quickly Make, Modify & Run posts yourself, whenever you need to
- Take Advantage of Foundation's advanced features such as Arc-fitting, High Speed Machining (HSM) and full Look-ahead functionality to make your parts better, cheaper and faster
- It's Easy-to-use, with full online "How-to" videos, a complete PDF user manual and it comes with a full library of ready-to-use default post-processors to get you into production even faster
- Includes extensive "Art-to-Part" examples that allow you to easily and quickly test your posts and CNC programs
- Freely Borrow and Share your Posts with the CAM-POST Foundation user community while taking advantage of the collective knowledge and skill they have to offer
- Foundation is based on ICAM's leading and proven technology used by industry's most demanding Aerospace, Defense and Automotive manufacturers
- Easily Migrate to all other ICAM Manufacturing Software Solutions
- Foundation is easy & inexpensive to buy and is available On-line! - [www.icam.com/Foundation](http://www.icam.com/Foundation)

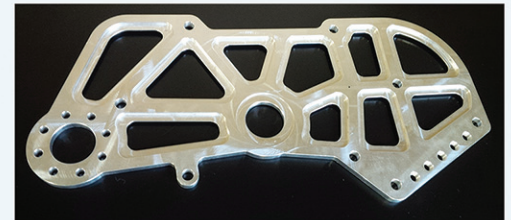

[www.icam.com/FOUNDATION](http://www.icam.com/FOUNDATION)



# CAM-POST FOUNDATION

## Post-Processor Generator for 2-Axis Lathes & 3-Axis Mills

For all Popular CAD/CAM Systems, Machine Tools and Controls



and more...

### CAM-POST FOUNDATION Post-Processors

CAM-POST FOUNDATION includes 50 metric & 50 imperial controller-based post-processors that are ready to execute inside major CAD/CAM systems such as CATIA, NX and Mastercam. All these post-processors can be edited to add specific machine tool functions (spindle speed, machine feedrate, coolant, tool change events, program header preferences, etc.) and can be shared by all CAM-POST FOUNDATION users.

These post-processors can also be used as templates to create completely new controller-based post-processors in addition to the library provided in CAM-POST FOUNDATION.

#### Basic 2-Axis Lathe Posts (Imperial & Metric)

Fagor 8065T	HURCO WinMax Lathe
Fanuc 0T	Mazak Fusion
Fanuc 10T	Mazak Matrix
Fanuc 15T	Mazak T2
Fanuc 18T	Mazak T32
Fanuc 21T	Mitsubishi M700/70L
Fanuc 30i-T	Mori-Seiki MSG501
Fanuc 31i-T	Okuma OSP L
Fanuc Oi-T	Siemens 810D T
Fanuc Oi-TD	Siemens 840D T
Haas SL/ST	Yasnac LX3 ...

#### Basic 3-Axis Mill Posts (Imperial & Metric)

FADAL 32MP (Format II)	Heidenhain 530
FADAL CNC88HS (Format II)	HURCO WinMax Mill
FAGOR 8065M	MAZAK FUSION 640M
FANUC 0M	MAZAK M2
FANUC 10M	MAZAK M32
FANUC 15M	MAZAK MATRIX
FANUC 21M	MITSUBISHI M700/70M
FANUC 30i-M	MORI-SEIKI MSG-501
FANUC 31i-M	Okuma OSP M
FANUC Oi-M	Siemens 810D M
HAAS	Siemens 840D M
Heidenhain 426	YASNAC MX3 ...



and more...

### You Are In Control

As a Foundation user, you don't need to rely on third party services to help you get (and keep) your machines up and running and to reach their maximum potential. Third party post suppliers rarely have the same unique knowledge about your machining environment as you do, or are as focused and flexible as you'd like.

With CAM-POST Foundation at your fingertips, you can respond rapidly to your own machining environment's unique needs by being in control of your post-processing needs on time and per your specifications.

### Pricing- Only \$49.95/Month

Are custom posts too expensive to buy and maintain? Now you can easily develop/modify them yourself and for a low cost.

No need to pay extra costs or maintenance fees to get someone else to create/modify your posts. Create, modify, and manage your own post-processors for only **\$49.95 per month**.

All product updates are included in the lease program, as well as comprehensive video training tutorials and reference manuals.

Still not sure? Try CAM-POST Foundation for 30 days for free. It's quick and easy to get started ...

... Sign up on our website and get your free 30 day trial! - [www.icam.com/Foundation](http://www.icam.com/Foundation)



ICAM Technologies Corporation  
21500 Nassr Street  
Sainte-Anne-de-Bellevue, Quebec  
Canada, H9X 4C1  
Toll Free: 1 (800) 827-ICAM  
International: 1 (514) 697-8033

