

Capabilities

Flexible and total EMC solutions



Our own European production facility in The Netherlands allows us to meet any challenge in providing Electromagnetic solutions for the medical, space and defense industries. This way we help our customers meeting specific EMC, CE, FCC, TEMPEST and MIL-STD standards for enclosures and gaskets.



In-house engineering and production



Shielded server room



Shielded high-voltage lab



Continuous water and EMI seal



Customized military TEMPEST enclosure

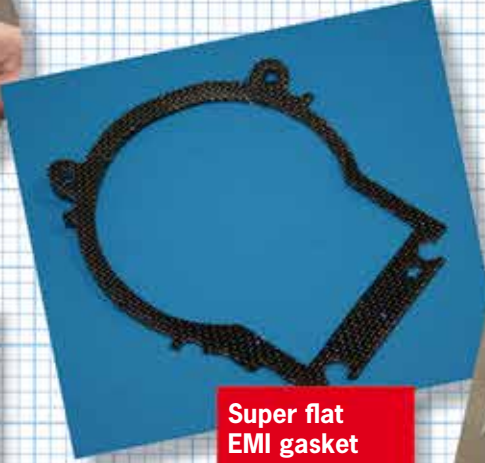

Super flat EMI gasket



Shielded ventilation for server racks



Shielded vehicle for radar jammer protection



Ultra high shielded window



In-house tests and measurements



Worldwide EMI gaskets overnight delivery



Material selection	Prevent galvanic corrosion	4
Design tips	Construction details / warranty	5
EMC profiles		
Standard shield 7000	For panels and screwed applications	6
Amucor shield 6800	Screwed applications for zink plated steel and aluminum	8
Ultra soft shield 7400	For doors and panels, very low closure force	10
Metal knit gaskets 1200	For military applications to shield lower frequencies	12
Finger strips 2000	For military applications and instruments	14
V-shape 8700	For doors, extremely low closure force	17
L-shape 7500	Water/EMI seal for doors	18
Miniature shield 1400	Very small EMI gaskets	19
EMC/IP profiles		
Clip-on shield 6500	Easy to mount clip-on EMI gasket with waterseal	20
EMC/IP 7300	Waterseal + EMI seal	21
O-profiles 7900	For application in grooves	22
Ultra soft twin shield 7800	Low closure force EMI/IP gasket	24
Customized gasket 8800	Any size and shape, EMI/IP gasket	25
Die-cut gaskets 8300	Gaskets die-cut according to client's drawing	26
Frame gasket 8100	For panels and screwed applications	27
Conductive sheet material		
Oriented wire shield 5711-5722	Sheet material to die-cut into complicated shapes	28
Conductive felt 5730	Non woven polyester with nickel coating	29
Conductive rubber 5750	Where less space is available / EMI-IP seal	30
Conductive foam 5770	EMI shield, low closure force, in any shape	31
EMI shielding products		
Conductive transparent foil 9000	To create transparent shielded windows	32
Conductive tapes 3200	In any width, with or without conductive adhesive	34
Shielding foils 5800	Die-cut/Jet cut in any shape	36
Cable shielding 4700/4800	For flat and round cables, can be installed afterwards	38
PCB shielding 1500/1600/1700	Shielding at the source, also in standard dimensions	40
Glue, coating & metallization	For plastic enclosures and housings	42
Connector gaskets 8200	All kinds of connector gaskets, also specials available	44
Faraday cages and components		
Windows 9700	Polycarbonate/Glass and acrylic	45
Wall paper system + ceiling	Mu-copper faraday cages	46
Shielding tents	High performance for high frequencies	48
Modular/anechoic cages	High performance in a wide frequency range	50
Doors	(Automatic) Leaf and sliding doors	52
Shielded box/data connections	Portable with high attenuation	53
Absorbers 3500	Sheets and pyramids	54
Magnetic shielding	Low frequency magnetic shielding	56
Power filters	Tubular and box filters	58
Ventilation panels 9500	Shielded vent panels/honeycombs for ventilation	60
Services and measurements		
HF/magnetic/EMC	On site measurements	62

Material Selection

Prevent galvanic corrosion

Materials / galvanic corrosion

To avoid galvanic corrosion it is important that the potential difference between the joined materials is not too high.

The difference in voltage between any two materials is an indication of their compatibility and the following criteria are commonly used:

- Harsh environment (exposure to salt spray/weathering)

no more than 0.3 volts

- Benign environment (indoors, salt-free condensation only)

no more than 0.5 volts

Material enclosure	Volts	Gasket material		
		Amucor shield	Ultra Soft shield/Monel	Tinned copper
Zinc die-casting alloy	- 1.10			
Zinc plating on steel, chromate passivated	- 1.05			
Cadmium plating on steel	- 0.80			
Aluminium, wrought, cast A1	- 0.75			
Iron and steel: not corrosion resisting	- 0.70			
Aluminium alloy/Amucor	- 0.65	*		
Duralumin	- 0.60			*
Tin plate (T.C.S.)	- 0.50			
Tin plating on steel	- 0.45			
Chromium plating on nickel plated steel	- 0.45			
Iron and steel: corrosion resisting, 12% Cr	- 0.45			
Iron and steel: corrosion resisting, high Cr	- 0.35		*	
Copper and its alloys, conductive fabric	- 0.25			
Nickel-copper alloys, incl. Monel	- 0.25			
Silver	0			
Carbon (colloidal graphite in acetone)	+ 0.10			
Gold	+ 0.15			
Platinum	+ 0.15			

Use a highly conductive gasket which is not too stiff to prevent deflection of the enclosure / heavy constructions.

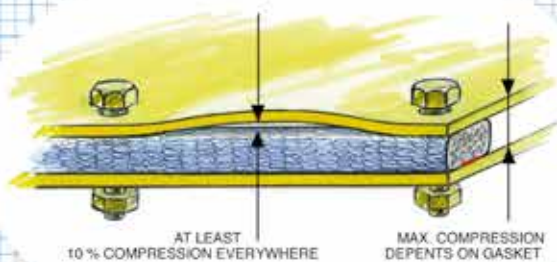

Prevent the use of mesh and other porous gaskets to get better coupling (high frequencies).

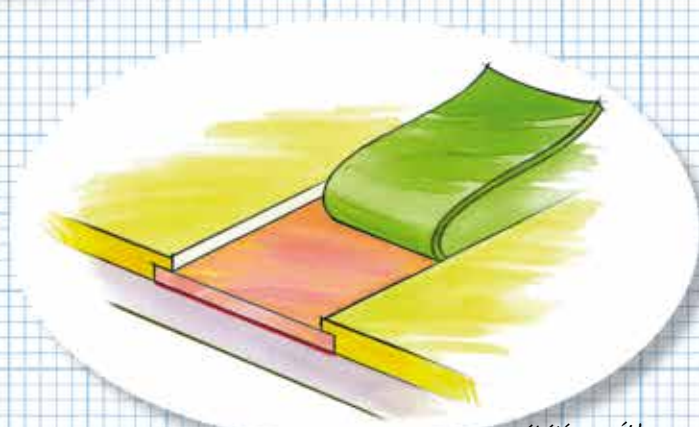

Use a gasket material which has good compatibility with the metal of the enclosure to prevent galvanic corrosion.

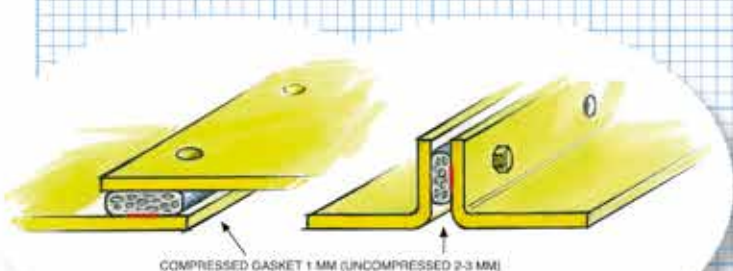

Connect sheets with an overlap or flanges.

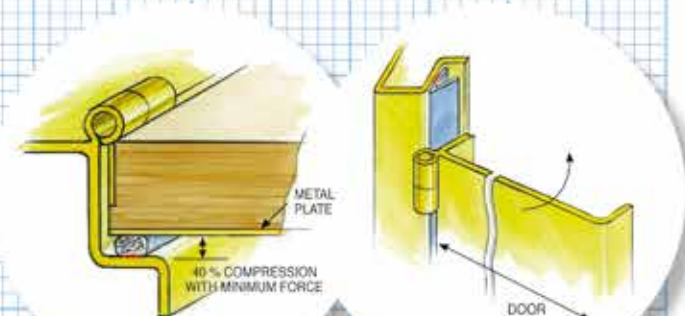

For doors, ultra soft shield or v-shape gaskets can be used to prevent a high closure force.

*Prevent interruptions in the shield.
An easy way to make curves.*

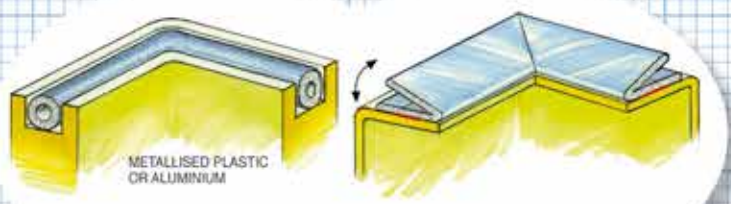
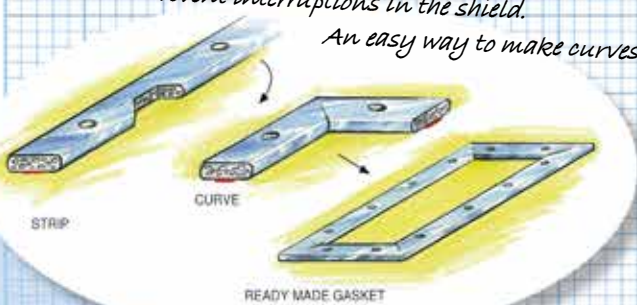

For small dimensions, {hollow} round profiles with a highly conductive textile / foil layer or v-shapes.

Design Tips

Construction details / warranty

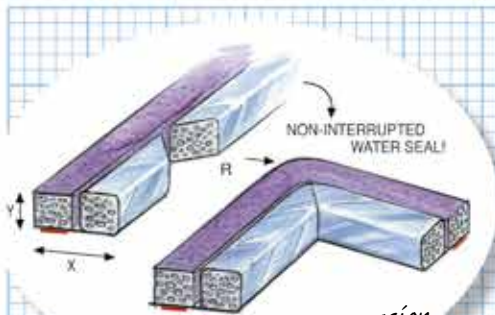

Keep water out to prevent corrosion.
Use uninterrupted combined EMI / water seals.

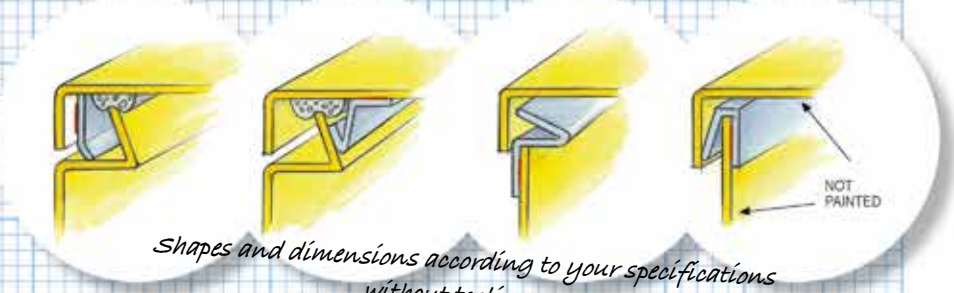

Shapes and dimensions according to your specifications without tooling costs.

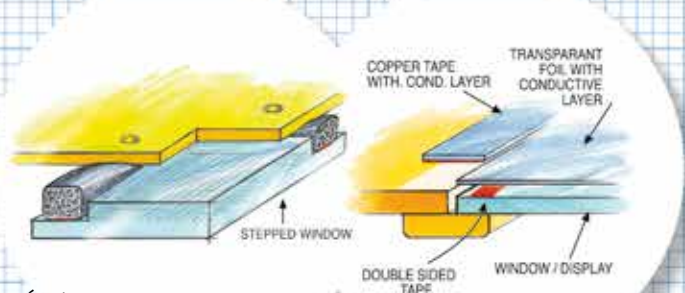

Windows / displays with mesh or conductive transparent foil, depending on frequencies/attenuation.

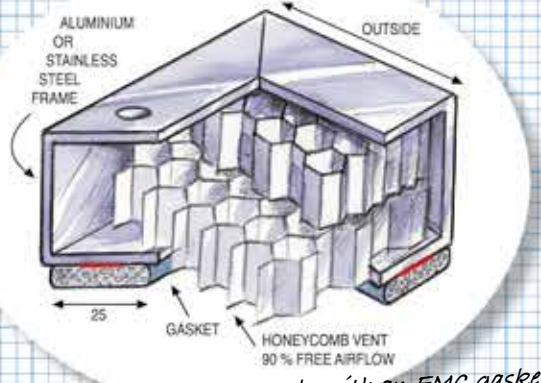

For ventilation use honeycombs with an EMC gasket.

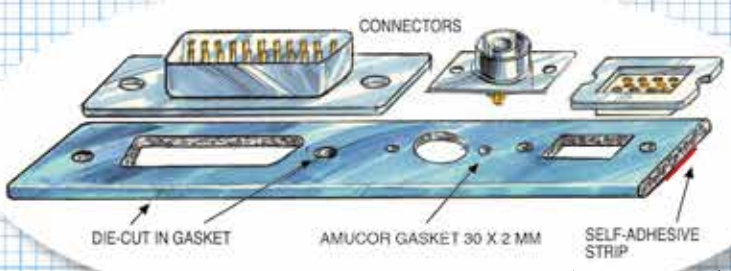

Use connector gaskets for low-impedance coupling to the enclosure.

Sometimes only a single component needs to be shielded.

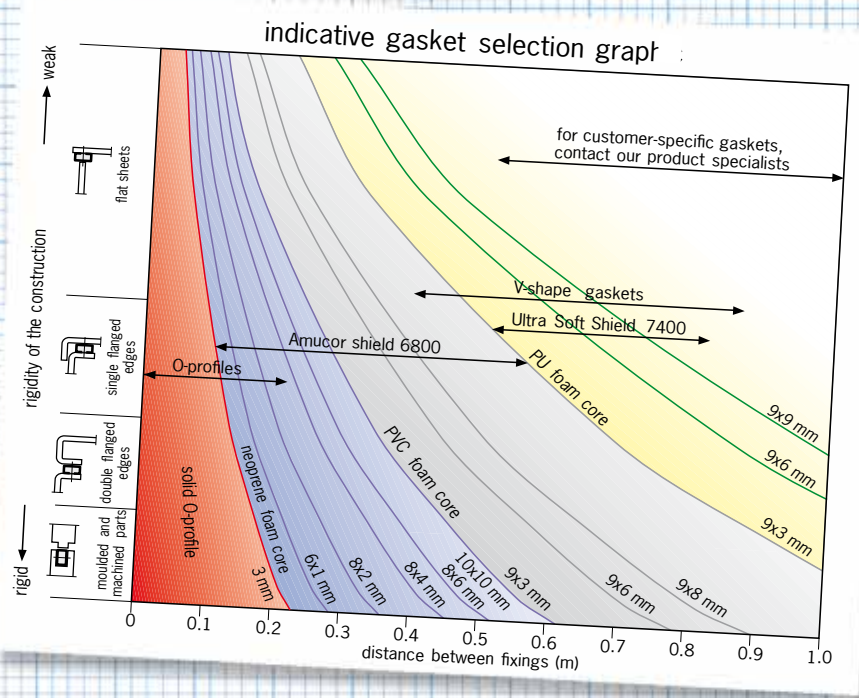
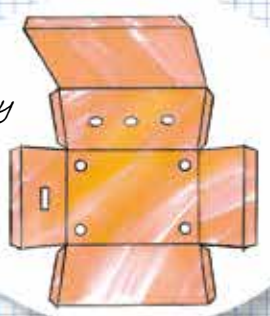

Type of gasket / dimension

Warranty

All Holland Shielding Systems products are continuously checked during the manufacturing process. Therefore all our products can be considered quality products, free of manufacturing errors.

The technical data of our products are based on research and should only be regarded as a guideline for the different applications. Due to the wide range of products and the large variety of applications the technical data are never to be interpreted as a guarantee. It is the buyer's responsibility to test whether the product meets the desired requirements.

In the event that, unexpectedly, defects should be found in our products, Holland Shielding Systems will investigate and replace these products as soon as possible. Holland Shielding Systems cannot be held responsible for any delays that might ensue.

Standard Shield 7000

General purpose / screwed joints

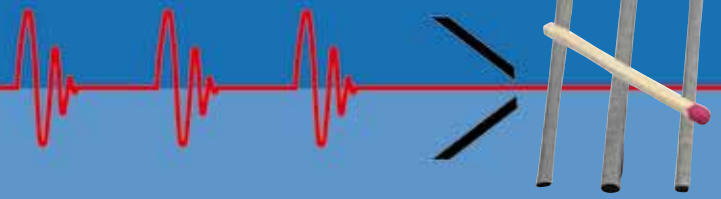

Standard Shield 7000, with self-adhesive strip

Standard Shield 7000 series

Standard Shield 7000 is an economical HF gasket which can be supplied in a wide range of dimensions. It is very effective in combination with stainless steel, copper and chrome-plated constructions.

All gaskets can be provided with a (conductive) self-adhesive strip.

Standard Shield 7000 consists of a neoprene or PVC foam core covered with textile. This guarantees excellent shielding performance and it is very strong.

For special applications, different foam cores, conductive foils and fabrics are available.

Benefits

- Self-adhesive EMC gasket
- Easy to fit, can be cut with scissors
- Good water resistance
- Gasket can be die-cut (screw holes)
- Roll lengths of 50, 100, 250 or 1000 m
- High shielding performance
- Low closure force
- EXTREMELY STRONG
- Deflection 50%

Options

- Cut into specific lengths
- Can be made die cut or frame
- Combination with water seal
- UL94V-0 flame retardant foam core
- Chemical resistant rubbers like EPDM
- Silicone sponge for high temperatures up to 220°C
- Different conductive foils and fabrics

Specifications

- Foam core : Open-celled neoprene foam
- Surface resistance : <0.08 square ohms
- Surface material : Conductive fabric (Polyester + Cu, Ni) (part no. 4711) see page 37
- Operating temperature : - 20°C / + 80°C
- Environmental : RoHS Compliant

Shielding Performance

Frequency Hz	Mode	Screening dB
1M	E	115
10M	E	108
100M	E	102
400M	E	92
1G	P	90
10 G	P	87
See Guarantee		

Shielding effectiveness depends on surface, shape of gaskets and material used.

Mechanical properties

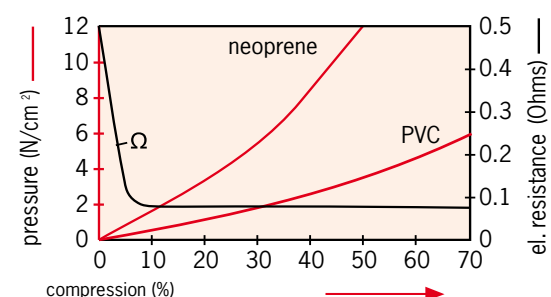

Standard Shield 7000

For panels and screwed applications

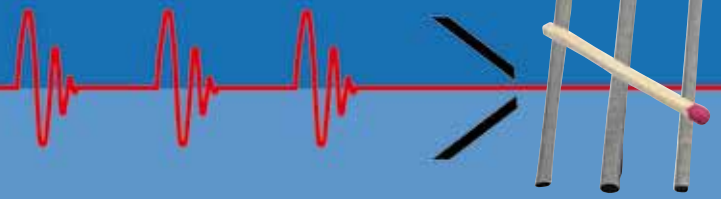

Adhesive specifications

(Standard type)

Our adhesive is a transparent double-sided tape consisting of a PP-film backing and a tackified acrylic adhesive.

- Backing material : PP film
- Color : Transparent
- Thickness of tape : 100 µm
- Type of adhesive : Tackified acrylic
- Elongation at break : 140 %
- Tensile strength : 20 N/cm
- Type of line : MOPP
- Thickness of liner : 80 µm
- Adhesion to steel : (after 14 days) 13,7 N/cm
- Adhesion to PET : (after 14 days) 8,5 N/cm

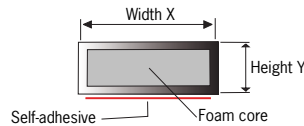

Dimensions

Height Y (mm)	Width X (mm)																
	1	2	3	4	5	6	7	8	9	10	12	15	18	20	25	32	50
1	7021	7031	7041	7051	7061	7071	7081	7091	70101	70121	70151	70181	70201	70251	70321	70501	
2	7022	7032	7042	7052	7062	7072	7082	7092	70102	70122	70152	70182	70202	70252	70322	70502	
3		7033	7043	7053	7063	7073	7083	7093	70103	70123	70153	70183	70203	70253	70323	70503	
4			7044	7054	7064	7074	7084	7094	70104	70124	70154	70184	70204	70254	70324	70504	
5				7055	7065	7075	7085	7095	70105	70125	70155	70185	70205	70255	70325	70505	
6					7066	7076	7086	7096	70106	70126	70156	70186	70206	70256	70326	70506	
8							7088	7098	70108	70128	70158	70188	70208	70258	70328	70508	
9								7099	70109	70129	70159	70189	70209	70259	70329	70509	
10									701010	701210	701810	701810	702010	702510	703210	705010	
12										701212	701812	701812	702012	702512	703212	705012	

Item numbers in **bold** are 98% stock items. Other dimensions on request.

EPDM rubber	700072	700068	700058	700064	700076	700051
Y x X mm	2 x 4 mm	3 x 6 mm	4 x 8 mm	8 x 12 mm	10 x 12 mm	16 x 20 mm
Y x X inch	.079" x .157"	.118" x .236"	.157" x .315"	.315" x .472"	.394" x .472"	.630" x .787"

Core specifications

(Standard Neoprene foam):

- Hardness shore 00 : 38-55 Sh 00
- Resistance when compressed : 25% 350-630 g/cm²
- Temperature °C (continuous) : - 40°C / + 85°C
- Temperature °C (peak) : 100°C
- Max. deformation (compressed) : 25%
- for 22 hrs at 70°C : 12%
- Recommended max. compression : 25%
- Resistance to cold : Good
- Resistance to air and ozone : Good
- Resistance to mineral oils : Good
- Resistance to vegetable oils : Good
- Resistance to acids : Good
- Resistance to chlorine solutions : Good
- Flame retardancy: : Self extinguishing

Ordering information

Example

Standard Shield 7000, 8 x 2 mm, standard self-adhesive placed in the middle, standard neoprene foam core: **7082-01-N**

Part number Tape code Foam code

7082 — **01** — **N**

01 : standard self-adhesive placed in the middle
02 : without self-adhesive
03 : with conductive self-adhesive (only recommended on small sizes)
06 : standard self-adhesive, asymmetrical
07 : standard self-adhesive placed on the side

N : standard neoprene foam
E : EPDM foam core
P : low closure force PVC foam, slow recovery
F : flame retardant UL94V-0 foam

Amucor Shield 6800

Screwed applications for zinc plated steel and aluminum



For panels
and screwed
applications.
With and without
self adhesive strip

Amucor Shield 6800 is an economical HF gasket which can be supplied in a wide range of dimensions. It is very effective in combination with zinc-plated steel and aluminium constructions.

All gaskets can be provided with a (conductive) self-adhesive strip.

Amucor Shield 6800 consists of a neoprene or PVC foam core covered with reinforced foil, based on an Amucor alloy. This guarantees excellent shielding performance and very great strength.

For special applications, different foam cores, conductive foils and fabrics are available.

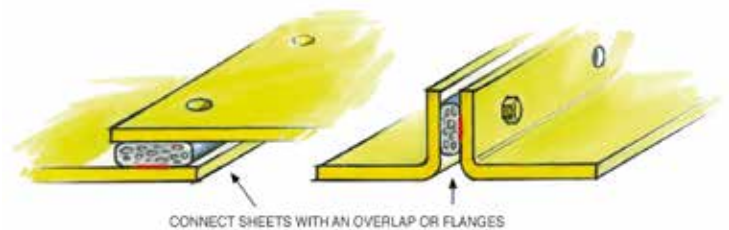

Options

- Cut into specific lengths
- Can be made die cut or frame
- Combination with water seal
- UL94V-0 flame retardant foam core
- Chemical resistant rubbers like EPDM
- Silicone sponge for high temperatures up to 220°C
- Different conductive foils and fabrics

Benefits

- Self-adhesive EMC gasket
- Easy to fit, can be cut with scissors
- Good water resistance
- Gasket can be die-cut (screw holes)
- Roll lengths of 50, 100, 250 or 1000 m
- High shielding performance
- Low closure force
- EXTREMELY STRONG
- Deflection 50%

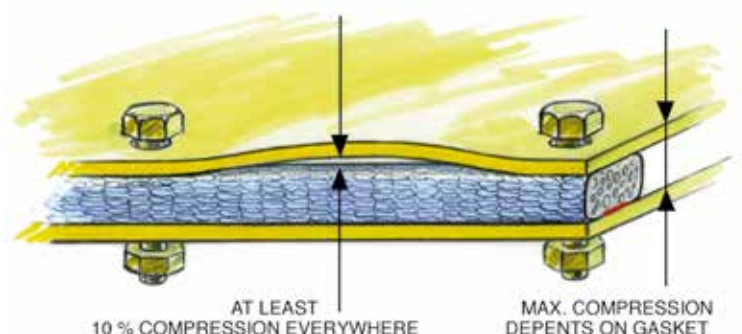

Amucor Shield 6800

For zinc plated steel and aluminum



Mechanical properties

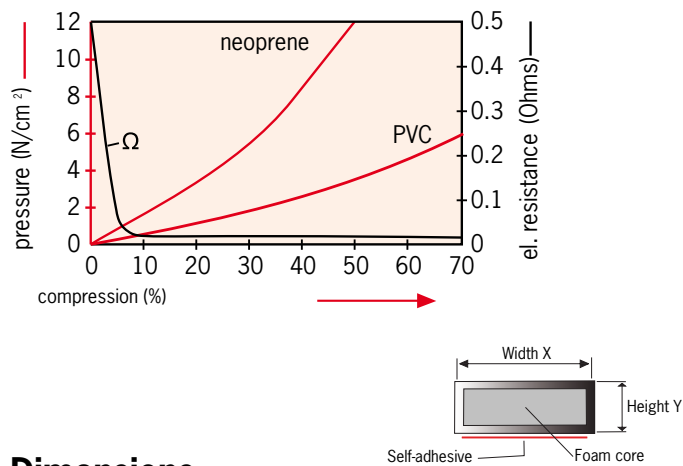

Dimensions

Height Y (mm)	Width X (mm)															
		2	3	4	5	6	7	8	10	12	15	18	20	25	32	50
1		6821	6831	6841	6851	6861	6871	6881	68101	68121	68151	68181	68201	68251	68321	68501
2		6822	6832	6842	6852	6862	6872	6882	68102	68122	68152	68182	68202	68252	68322	68502
3			6833	6843	6853	6863	6873	6883	68103	68123	68153	68183	68203	68253	68323	68503
4				6844	6854	6864	6874	6884	68104	68124	68154	68184	68204	68254	68324	68504
5					6855	6865	6875	6885	68105	68125	68155	68185	68205	68255	68325	68505
6						6866	6876	6886	68106	68126	68156	68186	68206	68256	68326	68506
8							6878	6888	68108	68128	68158	68188	68208	68258	68328	68508
10									681010	681210	681510	681810	682010	682510	683210	685010
12										681212	681512	681812	682012	682512	683212	685012

Item numbers in **bold** are 98% stock items. Other dimensions on request.

Shielding performance

Frequency Hz	Mode	Screening dB
1M	E	121
10M	E	110
100M	E	103
400M	E	98
1G	P	92
10G	P	89

See Guarantee

Shielding effectiveness depends on surface, shape of gaskets and material used.

Example

Amucor Shield 6800, 8 x 2 mm, standard self-adhesive placed in the middle, standard neoprene foam core: **6882-01-N**

Ordering information

Part number Tape code Foam code

6882 **01** **N**

01 : standard self-adhesive placed in the middle
02 : without self-adhesive
03 : with conductive self-adhesive (only recommended on small sizes)
06 : standard self-adhesive, asymmetrical
07 : standard self-adhesive placed on the side

N : standard neoprene foam
E : EPDM foam core
P : PVC foam, slow recovery
F : flame retardant UL94V-0 foam

Ultra Soft Shield 7400

For doors and panels, where very low closure force is required

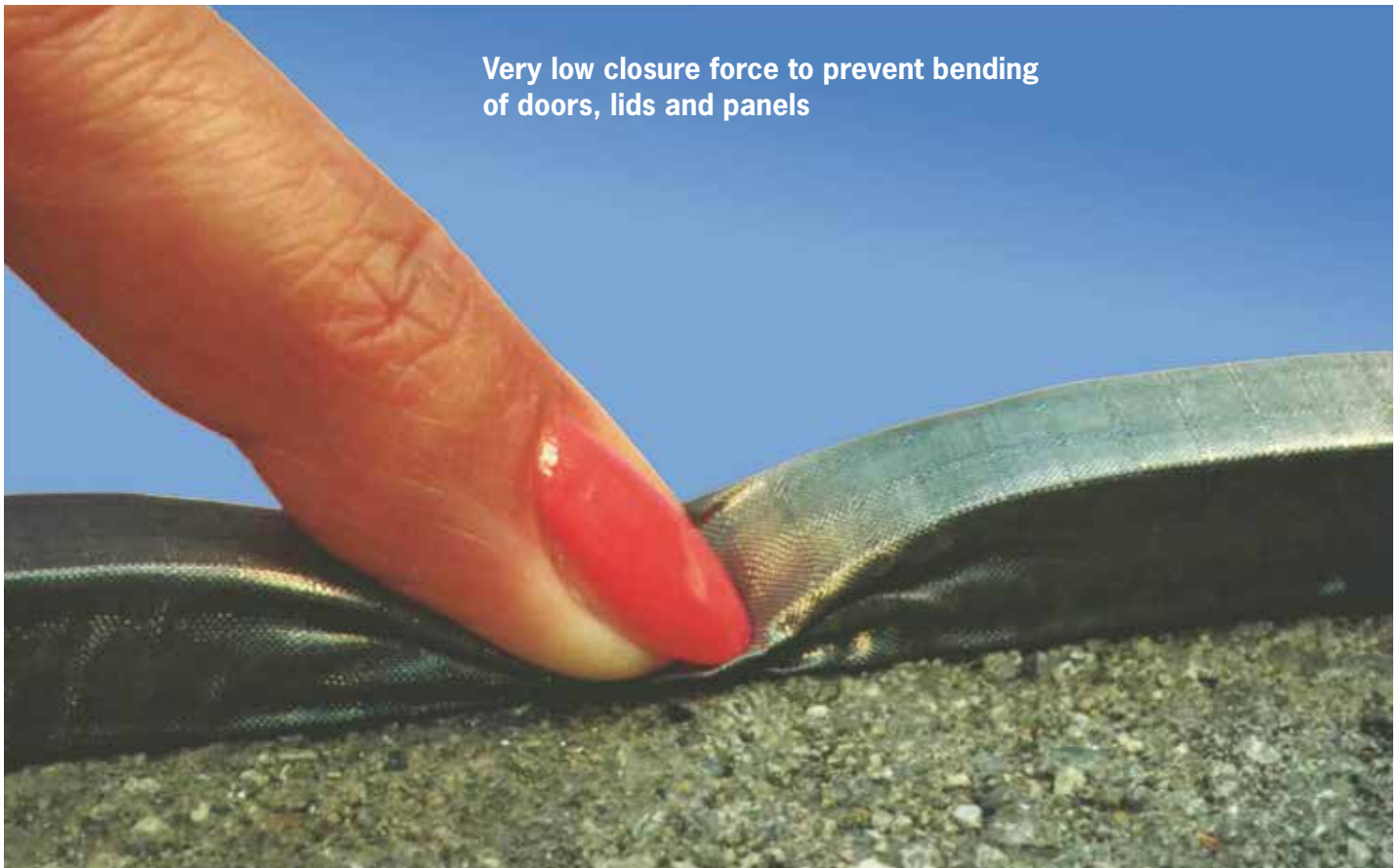
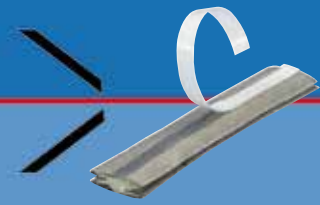

Very low closure force to prevent bending of doors, lids and panels

Ultra Soft Shield 7400 is an HF shielding gasket with high shielding performance and extremely low closure force. This prevents deflection of doors/parts, which improves shielding effectiveness.

The core consists of a high-grade polyurethane foam core with a maximum compression of 80%, which distinguishes Ultra Soft Shield 7400 from other commonly used shielding materials.

Ultra Soft Shield 7400 is covered with a highly conductive, wear and tear resistant metallized fabric.

Different foam cores, conductive foils and fabrics are available for special applications.

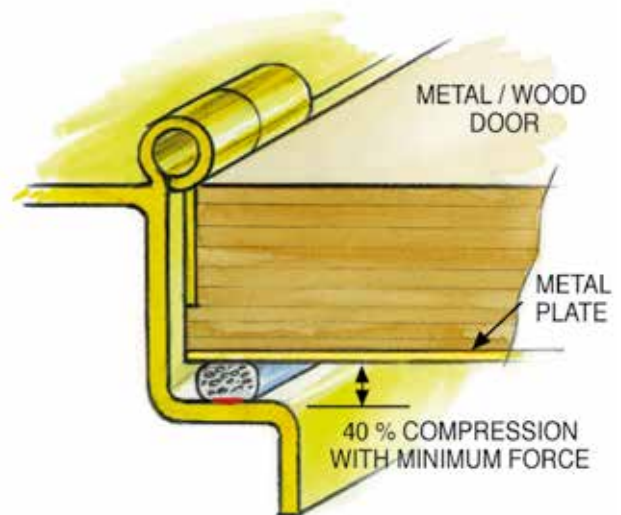

Shielding Performance

Frequency Hz	Mode	Screening dB
1M	E	115
10M	E	108
100M	E	102
400M	E	92
1G	P	90
10G	P	87
See Guarantee		

Shielding effectiveness depends on surface, shape of gaskets and material used.

Mechanical properties

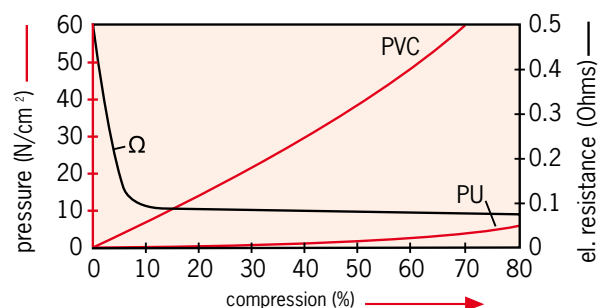

Ultra Soft Shield 7400

For doors and panels, where very low closure force is required

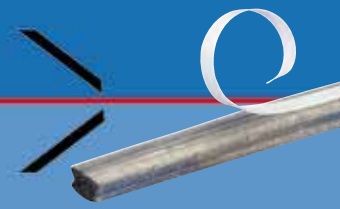

Benefits

- Deflection up to 80%
- Very low closure force
- Very high electric conductivity
- High shielding performance
- Roll lengths 50, 100, 250 or 1000 m
- Easy to fit, self-adhesive
- High abrasion resistance
- Tools required: a pair of scissors

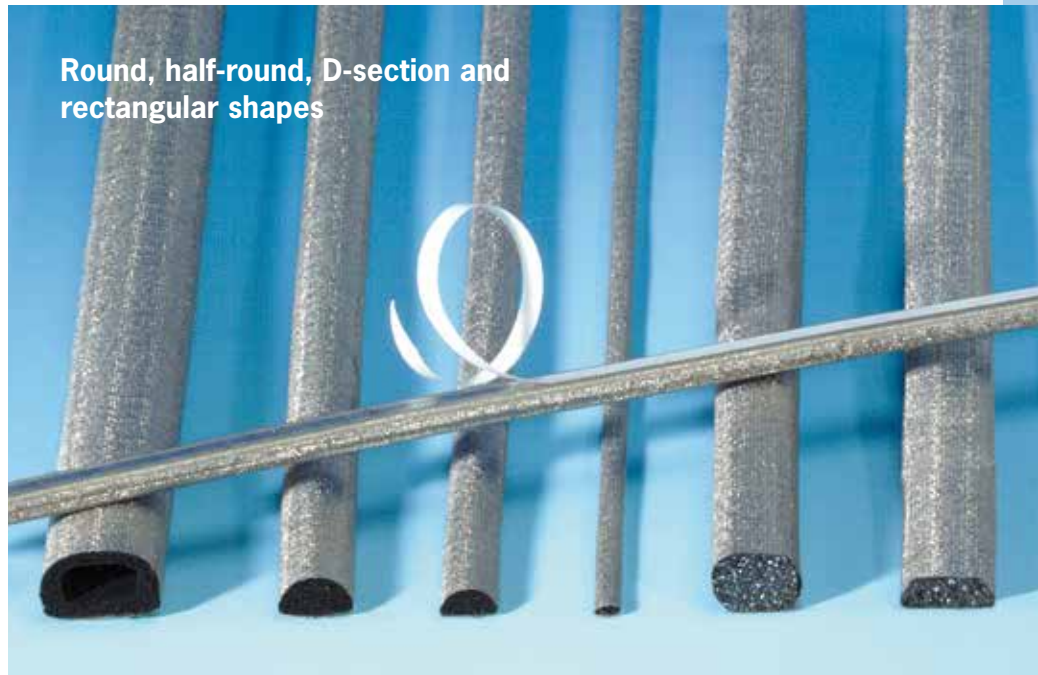

Round, half-round, D-section and rectangular shapes

Dimensions

Height Y (mm)	Width X (mm)										
	3	4	5	6	9	10	12	15	18	20	25
3		7443	7453	7463	7493	74103	74123	74153	74183	74203	74253
4		7444	7454	7464	7494	74104	74124	74154	74184	74204	74254
6				7466	7496	74106	74126	74156	74186	74206	74256
8					7488	74108	74128	74158	74188	74208	74258
9					7499	74109	74129	74159	74189	74209	74259
10						741010	741210	741510	741810	742010	742510
12							741212	741512	741812	742012	742512
15								741515	741815	742015	742515
18									741818	742018	742518
20										742020	742520
25											742525

Item numbers in **bold** are 98% stock items. Other dimensions on request.

EPDM rubber	740072	740068	740058	740064	740076	740051
Y x X mm	2 x 4 mm	3 x 6 mm	4 x 8 mm	8 x 12 mm	10 x 12 mm	16 x 20 mm
Y x X inch	.079" x .157"	.118" x .236"	.157" x .315"	.315" x .472"	.394" x .472"	16 x 20 mm

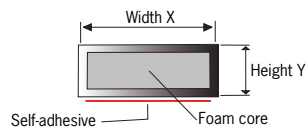

Options

- Cut into specific lengths
- Combination with water seal
- UL94V-0 flame retardant foam core
- Chemical resistant rubbers like EPDM
- Silicone sponge for high temperatures up to 220°C
- Different conductive foils and fabrics

Example

Ultra Soft Shield 7400, 9 x 6 mm, standard self-adhesive, placed in the middle, standard polyurethane foam core: **7496-01-P**

Ordering information

Part number	Tape code	Foam code
7496	01	P

01 : standard self-adhesive placed in the middle
02 : without self-adhesive
03 : with conductive self-adhesive (only recommended on small sizes)
06 : standard self-adhesive, asymmetrical

P : Standard polyurethane foam
F : flame retardant UL94V-0 foam

Metal Knit Gaskets 1200

For military applications, to shield lower frequencies

The 1200 series EMC gaskets consist of a core covered with knitted mesh. In most cases the gaskets are made of sponge, hollow tubes or extruded elastomers. For special applications like EMP or high temperatures a fully metal version is available.

Temperature resistance depends on the core material, but ranges from -60°C to 180°C. These gaskets are insensitive to external influences and can withstand harsh conditions very well. Also available with separate neoprene or silicone water seal.

The maximum deflection with a sponge elastomer core is approximately 30%, with hollow extrusion 50%. This is why the hollow type is used more often.



Knitted Mesh Gasket

Shielding performance

Frequency	Mode	Monel	Aluminium	TCS	S/Steel
10 KHz	H	45	40	60	40
100 KHz	H	49	45	65	44
1 MHz	H	60	60	85	58
1 MHz	E	125	125	125	125
10 MHz	E	120	120	120	120
100 MHz	E	100	100	108	100
400 MHz	P	98	95	99	94
1 GHz	P	85	76	78	76
10 GHz	P	80	65	62	60

See guarantee



For high frequency shielding, foil-based gaskets like Amucor Shield 6800 will perform better, due to their much larger contact surface. See image below.



contact points of mesh



contact surface of Amucor Shield

Advantages

- High attenuation level for lower frequencies
- Suitable for use under extreme conditions (military applications)
- Wear resistant
- Insensitive to corrosion

Technical specifications

Material	Applications
Monel Per QQ-N-281 BS 3075 N A 13 Class A diameter 0.11mm	The most commonly used material. Insensitive to corrosion and neutral on the galvanic scale.
Aluminium AMS 4187 BS 1475 5056A Alloy 5056 diameter 0.13mm	Is used in some cases for aluminium enclosures. Aluminium can be chrome-plated with an Alchrome 1200 layer, if necessary.
T.C.S. Steel Core(57%) Copper cladding(40%) Tin Plating (3%) diameter 0.11mm	This material has excellent magnetic as well as electrical properties, because a Ferro alloy is covered with copper. The outside is tin-plated to prevent corrosion.
Stainless steel AISI 304 diameter 0.13mm	The strongest material with a shielding performance that can be compared with aluminium. High resistance against wear.

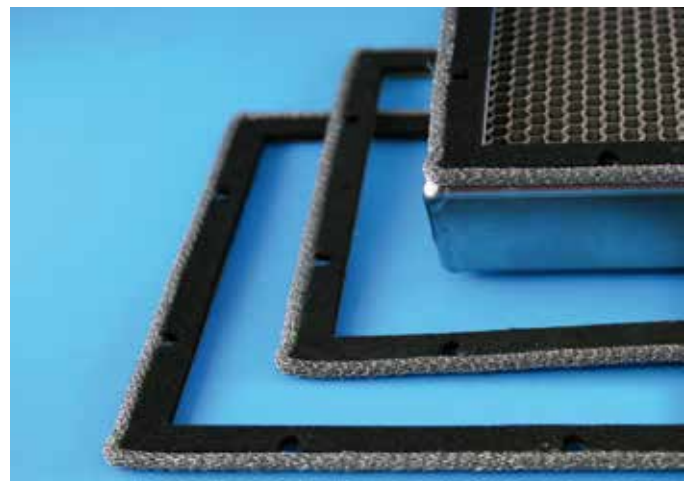

Metal Knit Gaskets 1200

For military applications to shield lower frequencies

Stock dimensions

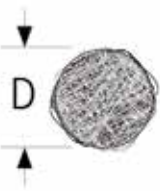

Fully metal round (R) D x d (mm)	
1.6 x 0	6.4 x 0
2.4 x 0	7.9 x 0
3.2 x 0	9.5 x 0
4.0 x 0	11.1 x 0
4.8 x 0	12.7 x 0

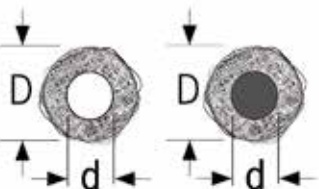

Hollow round (HR) D x d (mm)	
3.2 x 1.6	9.5 x 6.4
4.8 x 3.2	11.1 x 8.0
6.4 x 3.2	12.7 x 9.5
8.0 x 4.8	14.9 x 11.1

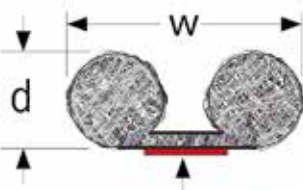

Double fully metal round (B) d x w (mm)	
1.6 x 9.5	4.8 x 15.9
1.6 x 12.7	4.8 x 19.1
1.6 x 15.9	4.8 x 25.4
2.4 x 12.7	6.4 x 15.9
3.2 x 9.5	6.4 x 19.1
3.2 x 12.7	6.4 x 25.4
3.2 x 15.9	

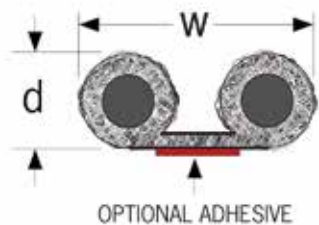

Double hollow round (HB) d x w (mm)	
3.2 x 9.5	6.4 x 15.9
3.2 x 12.7	6.4 x 19.1
3.2 x 15.9	6.4 x 25.4
4.8 x 15.9	9.5 x 25.4
4.8 x 19.1	
4.8 x 25.4	

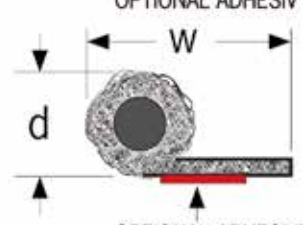

Hollow round with tail (HT) d x w (mm)	
1.6 x 12.7	4.8 x 12.7
1.6 x 15.9	4.8 x 15.9
1.6 x 19.1	4.8 x 19.1
2.4 x 12.7	4.8 x 25.4
2.4 x 19.1	6.4 x 12.7
3.2 x 12.7	6.4 x 15.9
3.2 x 16.0	6.4 x 19.1
3.2 x 19.1	6.4 x 25.4
4.0 x 12.7	9.4 x 19.1
4.0 x 19.1	9.4 x 25.4

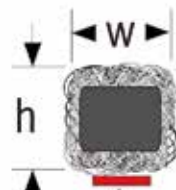

Hollow rectangular (HS) w x h (mm)	
2.4 x 3.2	4.8 x 4.8
2.4 x 4.8	4.8 x 6.4
2.4 x 6.4	4.8 x 9.5
3.2 x 3.2	6.4 x 6.4
3.2 x 4.8	6.4 x 9.5
3.2 x 6.4	6.4 x 12.7
3.2 x 9.5	

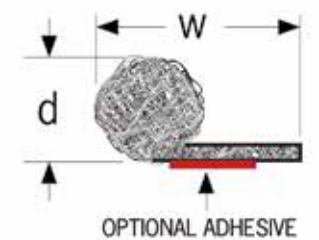

Fully metal round with tail (T) d x w (mm)	
1.6 x 9.5	7.9 x 15.9
1.6 x 12.7	7.9 x 19.1
1.6 x 15.9	7.9 x 25.4
2.4 x 12.7	9.5 x 15.9
2.4 x 15.9	9.5 x 19.1
3.2 x 12.7	9.5 x 25.4
3.2 x 15.9	11.1 x 19.1
4.0 x 12.7	11.1 x 25.4
4.0 x 19.1	12.7 x 19.1
4.8 x 15.9	12.7 x 25.4
4.8 x 19.1	
4.8 x 25.4	
6.4 x 15.9	
6.4 x 19.1	
6.4 x 25.4	

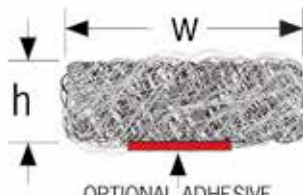

Fully metal rectangular (S) w x h (mm)	
3.2 x 1.6	15 x 12
3.2 x 3.2	15 x 15
3.2 x 4.0	15.9 x 9.5
3.2 x 4.8	19.1 x 12.7
3.2 x 6.4	20 x 6
4.8 x 4.8	20 x 8
6.4 x 1.6	20 x 10
6.4 x 3.2	20 x 12
6.4 x 6.4	20 x 20
9.5 x 6.4	25 x 6
12.7 x 6.4	25 x 8
12.7 x 9.5	25 x 10
12.7 x 12.7	25 x 12
15 x 6	25 x 18
15 x 8	25 x 20
15 x 10	

All knitted mesh gaskets can be produced with water seal.

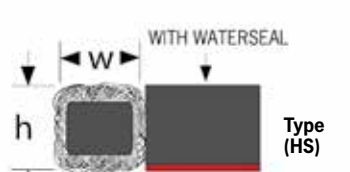
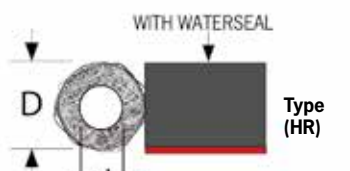
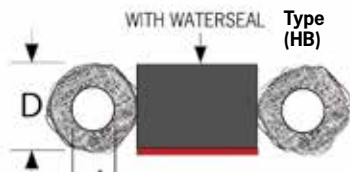

Ordering information

Serie	Core	Material	Shape	Dimensions (mm)	Waterseal	Width (mm)
1200	C	M	S	3.2 x 1.6	S	10
	<ul style="list-style-type: none"> N : Not important F : Full metal H : Hollow silicone C : Neoprene S : Silicone E : EPDM O : Hollow 	<ul style="list-style-type: none"> N : Not important M : Monel T : TCS A : Aluminium S : Stainless steel E : Steel 	<ul style="list-style-type: none"> R : Fully metal round HR : Hollow round B : Double fully metal round HB : Double hollow round T : Fully metal round with tail HT : Hollow round with tail S : Fully metal rectangular HS : Hollow rectangular 		<ul style="list-style-type: none"> S : Standard waterseal P : Soft "P" seal N : No waterseal 	Specify the width of the waterseal in mm

Fingerstrips 2000

For military applications / clip-on, snap-on and stick-on fingerstrips

For high performance applications, Beryllium Copper fingerstrips offer the best EMI shielding effectiveness, used in the right construction. The mechanical spring characteristics far surpass all other gaskets in the industry, but due to the toxicity of beryllium these strips are not always allowed. Therefore many shapes are also available in stainless steel. The contact of the Beryllium copper fingerstrip tolerates a wiping or sliding action, so it is ideal for applications where frequent opening and closing operations are likely. The product comes in a wide range of profiles (see www.fingerstrips.com) and is also available in various plated versions.

Standard length of 406 mm; some shapes also in 610 mm or on rolls.

2100 - Clip-on mounting series

For applications where a small dynamic range is required and a clip-on mounting is preferred

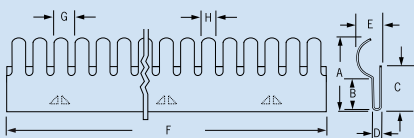

Clip on 2102

Part Number	A	B	C	D	E	F	G	H
2102-01	11,4	2,5	6,9	1,0	3,6	406	4,8	3,6
2102-02	11,4	2,5	6,4	1,5	4,1	406	4,8	3,6
2102-03	11,4	2,5	5,8	2,0	4,6	406	4,8	3,6
2102-04	11,4	2,5	6,6	1,3	3,9	457	4,8	3,8
2102-05	11,4	2,5	6,1	1,8	4,4	457	4,8	3,8
2102-06	11,9	3,0	5,1	2,0	2,7	457	4,8	3,8

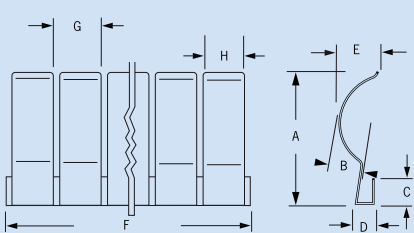

Clip on 2103

Part Number	A	B	C	D	E	F	G	H
2103-01	27,8	5,5	6,0	3,4	8,1	406	9,5	8,7
2103-02	27,7	6,6	6,6	2,3	8,9	457	9,5	8,5
2103-03	27,7	6,6	6,6	3,2	9,8	457	9,5	8,5

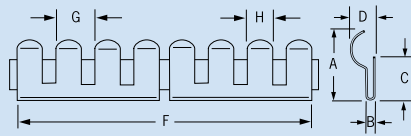

Clip on 2105

Part Number	A	B	C	D	F	G	H
2105-01	6,9	0,8	7,1	2,3	406	6,4	5,6
2105-02	6,9	1,0	7,1	2,5	406	6,4	5,6
2105-03	7,1	0,8	6,9	2,3	406	6,4	5,6
2105-04	7,1	1,0	6,9	2,5	406	6,4	5,6
2105-05	7,6	1,0	5,4	2,5	406	4,6	3,5
2105-06	7,8	0,8	4,8	3,8	406	4,8	3,6
2105-07	7,8	1,0	4,8	4,0	406	4,8	3,6
2105-08	7,8	1,5	4,8	4,5	406	4,8	3,6
2105-09	7,9	1,3	-	3,8	406	4,6	3,4
2105-10	7,9	1,5	-	4,0	406	4,6	3,4
2105-11	10,7	0,8	4,5	4,4	406	4,8	3,6
2105-12	10,7	1,5	4,5	5,1	406	4,8	3,6
2105-13	10,7	1,0	-	3,0	406	4,8	3,6
2105-14	10,7	1,3	-	3,3	406	4,8	3,6
2105-15	10,7	1,5	-	3,5	406	4,8	3,6
2105-16	15,2	1,0	-	5,2	406	4,6	3,4
2105-17	15,2	1,5	-	5,2	406	4,6	3,4
2105-18	15,6	0,8	4,8	5,1	406	4,8	3,6
2105-19	15,6	1,0	4,8	5,3	406	4,8	3,6
2105-20	15,6	1,5	4,8	5,8	406	4,8	3,6

2200 - Snap-on mounting series

Mounting through holes in your construction. You can mount by pushing into position.

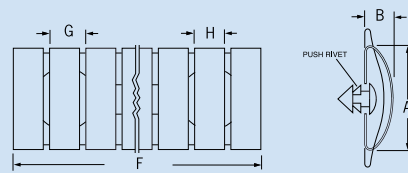

Snap on 2202

Part Number	A	B	F	G	H
2202-02	9,6	2,8	381	4,8	4,3
2202-04	13,0	3,6	381	4,8	4,3
2202-05	19,3	5,6	381	9,6	8,8

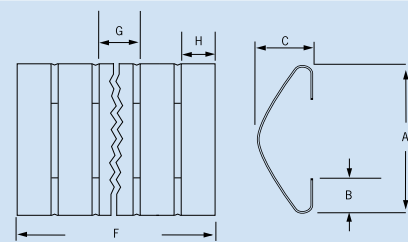

Snap on 2203

Part Number	A	B	C	F	G	H
2303-01	7,6	1,9	3,3	406	4,8	4,3
2303-02	8,1	-	2,5	406	4,8	4,2
2303-03	8,1	-	2,8	406	4,8	4,3
2303-06	9,4	-	3,3	400	6,4	5,7
2303-08	15,3	3,6	5,6	400	7,3	6,4
2303-09	15,3	-	5,6	400	9,5	8,7
2303-10	20,3	-	8,1	400	9,5	8,7

2300 - Stick-on mounting series

Mounting with self-adhesive

2301 - 2303 Stick-on mounting for gaps from 0 to 3 mm

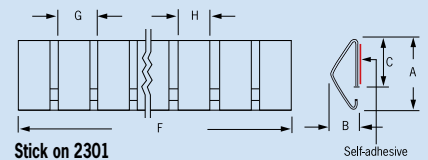

Stick on 2301

Part Number	A	B	C	F	G	H
2301-01	7,1	2,8	4,6	610	4,8	4,3
2301-02	7,9	3,0	4,3	457	4,8	4,3
2301-03	8,1	2,8	5,3	406	4,8	4,3
2301-04	8,2	2,7	5,7	406	4,8	4,3

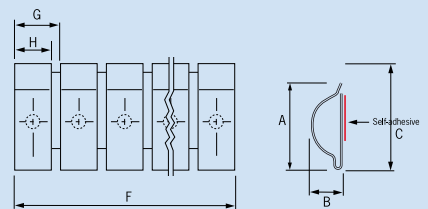

Stick on 2302

Part Number	A	B	C	F	G	H
2302-01	7,1	2,8	5,8	406	4,8	4,3

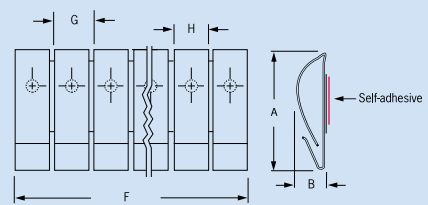

Stick on 2303

Part Number	A	B	F	G	H
2303-01	6,4	2,3	406	4,8	4,3
2303-02	9,7	3,0	406	4,8	4,3
2303-03	13,0	3,8	406	6,4	5,8
2303-04	19,0	4,8	610	9,5	8,8
2303-05	19,3	5,8	610	8,7	9,5

2331 - 2334 Stick-on mounting for gaps from 3 to 6 mm

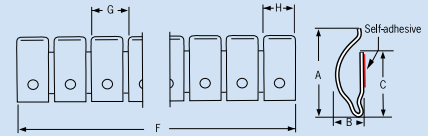

Stick on 2331

Part Number	A	B	C	F	G	H
2331-01	7,1	2,8	5,8	406	4,8	4,3
2331-05	19,3	6,4	11,9	610	9,5	8,5

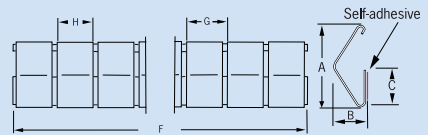

Stick on 2334

Part Number	A	B	C	F	G	H
2334-04	9,4	3,3	5,3	406	6,3	5,7

Fingerstrips 2000

For military applications / stick-on, twisted and angled fingerstrips

For dimensions and more types of fingerstrips please take a look at www.fingerstrips.com or contact us by mail or phone

2362 - 2365 Stick-on mounting for gaps from 6 to 11 mm

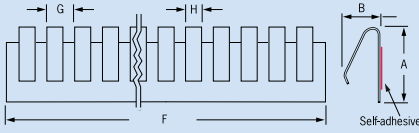

Stick on 2362

Part Number	A	B	C	F	G	H
2362-01	7,1	2,8	5,8	406	4,8	4,3

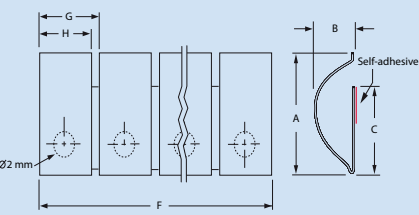

Stick on 2363

Part Number	A	B	C	D	F	G	H
2363-02	10,7	4,3	5,6	1,3	406	6,3	5,7
2363-03	10,7	4,6	5,6	1,5	508	6,3	5,7
2363-05	16,3	7,0	5,6	1,5	457	9,5	8,7

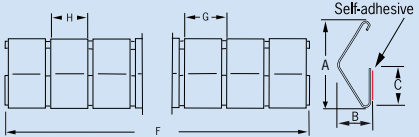

Stick on 2364

Part Number	A	B	C	F	G	H
2364-03	19,8	8,1	11,2	457	9,5	8,7
2364-04	27,9	10,2	19,8	457	12,7	11,7

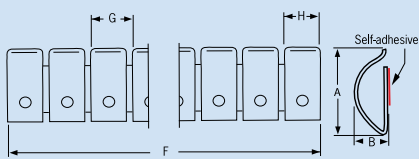

Stick on 2365

Part Number	A	B	F	G	H
2365-01	18,7	6,8	610	9,5	8,5
2365-02	19,8	6,4	610	9,5	8,5
2365-03	29,0	12,0	610	12,7	11,7

2400 - Twisted series 0.2 - 1.8 mm

For small gaps and screwed applications

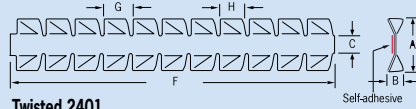

Twisted 2401

Part Number	A	B	C	F	G	H
2401-01	12,5	1,6	4,8	610	4,2	3,7
2401-02	12,7	1,8	4,8	610	4,2	3,8

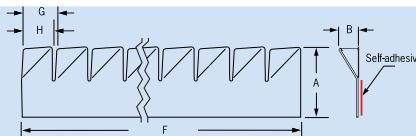

Twisted 2402

Part Number	A	B	F	G	H
2402-01	5,8	0,8	610	2,4	2,0
2402-02	8,6	1,6	610	4,2	3,7
2402-03	12,7	3,1	610	6,0	5,4

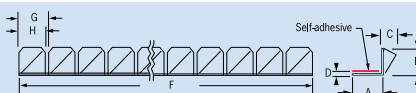

Twisted 2403

Part Number	A	B	C	D	F	G	H
2403-01	3,6	2,0	0,8	0,08	610	2,4	2,0
2403-02	3,6	2,2	0,7	0,08	610	2,4	2,0
2403-03	4,6	4,0	1,8	0,08	610	4,2	3,8
2403-04	4,8	3,8	1,8	0,08	610	4,2	3,8

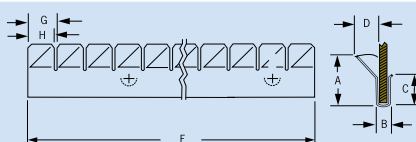

Twisted 2404

Part Number	A	B	C	D	F	G	H
2404-01	3,8	1,0	3,0	0,8	406	2,4	2,0
2404-02	3,8	1,5	2,5	0,8	406	2,4	2,0
2404-03	4,1	1,0	4,0	0,8	406	2,4	2,0
2404-04	4,1	1,5	3,5	0,8	406	2,4	2,0
2404-05	4,8	1,0	3,3	1,8	406	4,5	3,8
2404-06	4,8	1,5	3,0	1,8	406	4,5	3,8
2404-07	4,8	2,0	2,8	1,8	406	4,5	3,8
2404-08	5,8	1,0	4,0	0,8	406	4,2	3,8
2404-09	5,8	1,5	3,5	1,8	406	4,2	3,8
2404-10	6,4	1,0	5,1	1,8	406	4,2	3,8
2404-11	6,4	1,5	4,6	1,8	406	4,2	3,8
2404-12	6,4	2,0	4,1	1,8	406	4,2	3,8

2500 - Angle series 4.8 - 10.3 mm

For use under 90° mounting

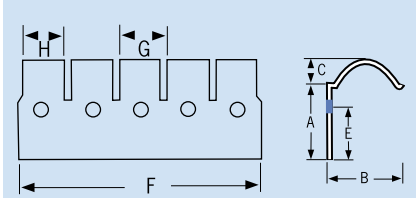

Angle Fingerstrips 2501

Part Number	A	B	C	Ø	E	F	G	H
2501-01	13,5	19,8	6,4	3,6	14,3	406	9,5	8,5
2501-02	19,5	28,7	10,3	3,6	14,3	406	12,7	11,7

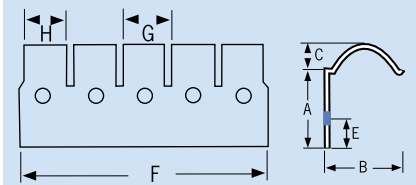

Angle Fingerstrips 2502

Part Number	A	B	C	Ø	E	F	G	H
2502-1	6,1	7,1	2,8	1,5	2,0	406	4,8	4,3
2502-2	7,8	9,4	3,8	1,6	2,4	406	6,2	5,8
2502-3	12,7	15,2	5,8	2,0	7,9	406	9,5	8,7

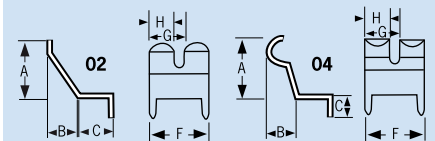
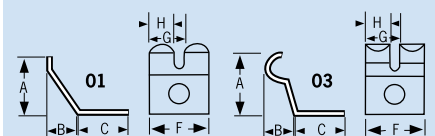

Angle Fingerparts 2504 (short pieces)

Part Number	A	B	C	Ø	F	G	H
2504-01	8,0	4,0	7,0	2,6	8,4	4,8	3,6
2504-02	8,0	4,0	3,0	2,6	5,0	4,8	3,6
2504-03	8,2	3,5	7,0	2,6	8,4	4,8	3,6
2504-04	8,2	3,5	3,0	2,6	5,0	4,8	3,6



Fingerstrips 2000

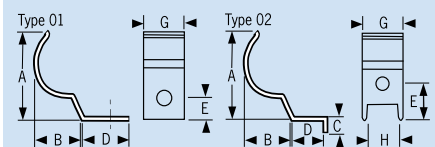

Angle Fingerparts 2505 (short pieces)

Part Number	A	B	C	D	Ø	E	G	H
2505-01	18,7	10,0	3,0	10	2,6	7,0	8,5	5,0
2505-02	17,7	10,0	-	10	3,6	4,0	8,5	-

Fingerstrips 2000

For military applications / circular, contact and door fingerstrips



2600 - Curcular series 0.8 - 6 mm gap

For round contacts

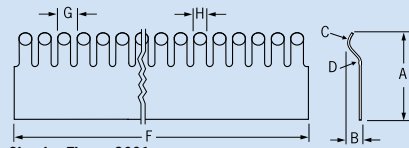

Circular Finger 2601

Part Number	A	B	C	D	F	G	H
2601-01	8,7	1,0	-	-	406	1,5	1,0
2601-02	9,5	1,0	1,2r	-	500	1,5	1,0
2601-03	9,7	1,3	-	-	406	1,9	1,3
2601-04	13,5	1,3	-	-	406	1,9	1,3
2601-05	14,0	1,1	1,5r	1,5r	500	4,0	3,0
2601-06	14,1	0,8	2,0r	-	500	2,0	1,5
2601-07	18,5	1,1	1,5r	1,5r	500	4,0	3,0
2601-08	19,1	3,1	-	-	406	4,8	3,6
2601-09	22,6	3,0	-	-	406	4,8	3,6
2601-10	30,0	3,0	2,5r	-	500	4,0	3,0

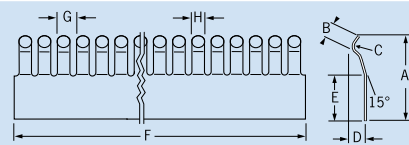

Circular Finger 2602

Part Number	A	B	C	D	E	F	G	H
2602-01	9,2	1,0	1,2r	2,5	3,6	500	1,5	1,0
2602-02	13,8	1,1	1,5r	-	8,0	500	4,0	3,0
2602-03	13,9	0,8	2,0r	3,0	6,0	500	2,0	1,5
2602-04	18,3	1,1	1,5r	-	8,0	500	4,0	3,0
2602-05	27,4	3,0	2,5r	11,0	10,0	500	4,0	3,0

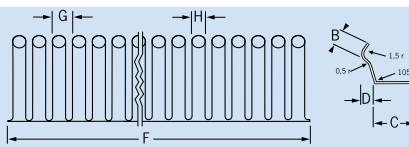

Circular Finger 2603

Part Number	A	B	C	D	F	G	H
2603-01	5,5	1,0	3,9	2,1	500	2,0	1,5
2603-02	7,8	0,8	6,0	2,5	500	1,5	1,0
2603-03	11,0	1,1	8,0	-	500	4,0	3,0

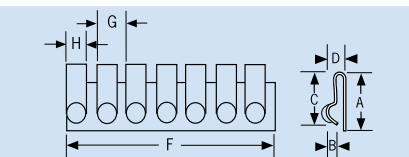

Circular Finger 2604

Part Number	A	B	C	D	F	G	H
2604-01	4,8	2,3	4,1	-	406	1,5	1,0
2604-02	6,6	2,8	5,8	-	406	1,9	1,3
2604-03	7,0	0,8	6,5	2,6	500	1,5	1,0
2604-04	9,1	1,1	7,7	4,5	500	4,0	3,0
2604-05	11,2	-	8,2	4,1	406	2,4	1,6
2604-06	11,5	1,1	9,8	4,5	500	3,0	3,0

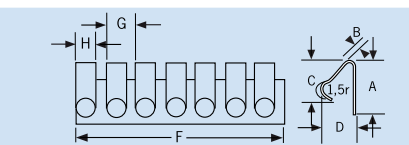

Circular Finger 2605

Part Number	A	B	C	D	F	G	H
2605-01	7,0	0,8	5,5	4,9	500	2,0	1,5
2605-02	9,5	1,1	6,4	7,0	500	4,0	3,0
2605-03	12,0	1,1	8,4	8,0	500	4,0	3,0

2700 - Contact series 1.3 - 10.4 mm gap

Contact strips with a dynamic range

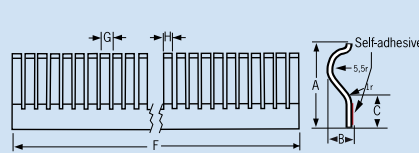

Contact Finger 2701

Part Number	A	B	C	D	F	G	H
2701-01	24,5	6,5	8,0	17,0	500	4,0	3,0
2701-02	27,7	6,6	-	-	10m	9,5	8,7
2701-03	42,4	10,4	-	-	7m	12,7	11,7

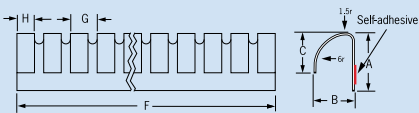

Contact Finger 2702

Part Number	A	B	C	F	G	H
2702-01	3,3	1,8	2,5	304	1,5	1,0
2702-02	3,3	2,3	2,5	304	3,2	2,0
2702-03	7,1	3,3	6,4	406	3,4	2,3
2702-04	7,1	3,3	6,4	406	3,7	2,8
2702-05	7,1	5,1	4,8	406	3,4	2,3
2702-06	9,7	4,8	7,3	406	4,8	3,6
2702-07	12,2	7,1	8,9	406	4,8	3,2
2702-08	16,0	11,2	10,4	406	3,4	2,2

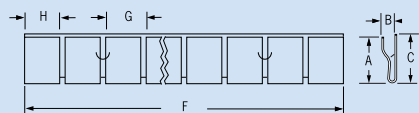

Contact Finger 2703

Part Number	A	B	C	D	F	G	H
2703-01	5,0	2,6	6,5	-	406	1,5	0,5

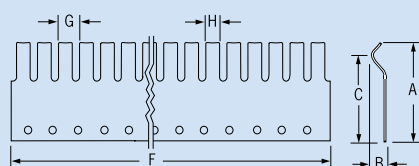

Contact Finger 2704

Part Number	A	B	C	F	G	H
2704-01	30,0	3,0	25,0	500	4,0	3,0

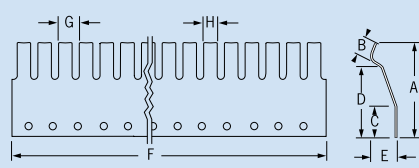

Contact Finger 2705

Part Number	A	B	C	D	E	F	G	H
2705-01	29,1	3,0	10,0	23,5	7,0	500	4,0	3,0
2705-02	27,5	3,0	10,0	22,0	9,0	500	4,0	3,0

2800 - Doorstrips 6.4 - 10.3 mm gap

Fingerstrips used for shielding doors

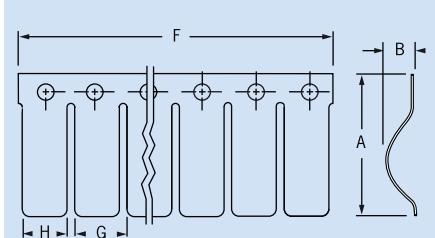

Door Finger 2801

Part Number	A	B	C	Ø	F	G	H
2801-01	27,7	6,4	0,1	3,6	503	9,5	8,5
2801-02	39,5	10,3	0,2	3,6	503	12,7	11,7

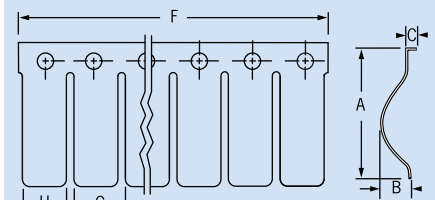

Door Finger 2802

Part Number	A	B	C	Ø	F	G	H
2802-01	25,7	6,4	2,0	3,6	503	9,5	8,5



V-shape 8700

For doors, extremely low closure force

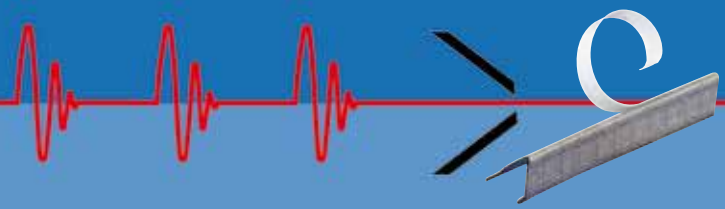

The 8700 series V-shape gaskets are characterised by a very large compression range and low closure force. They come with a self-adhesive strip for easy mounting. The most common version is with conductive Nickel over Copper textile (T). The version with highly conductive Amucor foil (A) is designed especially for a combination with aluminum and zinc plated steel. To prevent loss of material and for easy shipping we can cut exact lengths. Maximum lengths 2.5 meter.

Also available with a resilient foam rubber insert (i) for more compression just at the moment of closing.

The 8700 series is flame retardant, which can be supplied in a UL94V-0 compliant version.

If applied as shown in Fig. 3, excellent shielding can be achieved without any permanent closure force. This construction prevents bending of doors, so the enclosure can be less rigid. Also for hinges and locks.



For doors: gaskets with low closure force, to prevent bending of doors, lids and panels

Shielding Performance

Frequency Hz	Mode	Shielding dB
1M	E	115
10M	E	108
100M	E	102
400M	E	92
1G	P	90
10G	P	87
See Guarantee		

Shielding effectiveness depends on surface, shape of gaskets and material used.

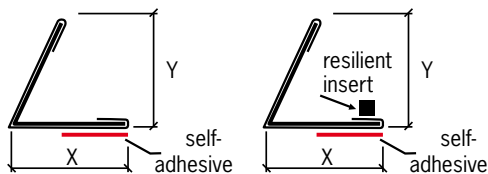
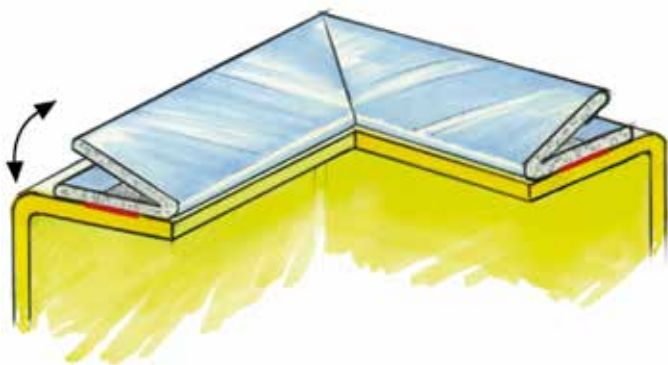

Dimensions

Part no.	8733	8744	8755	8766	8777	8788	87107	871212	871818	872020
width X (mm)	3	4	5	6	7	8	10	12	18	20
range Y (mm)	0.3-1.5	0.32	0.32-5	0.6-3	0.6-4	0.64	0.6-5	0.66	1-9	1-10

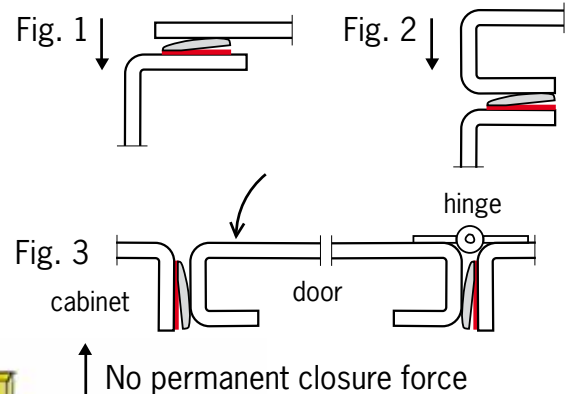

Benefits

- Self-adhesive
- Easy to fit
- Allows large tolerances
- High shielding performance
- Very high deflection
- Low closure force

Ordering information

Example

Part number 87107 with conductive textile and resilient insert at a length of 1940 mm: **87107 -T -i -1940**

Part number	Material	Insert	Length (mm)
87107	T	i	1940
Specify the part number from the dimensions table	T : Conductive textile A : Amucor foil	Specify (i) for a resilient foam rubber	Specify the length (mm) Max. length 2500 mm. Other on request. Keep small for economic transport

L-shape 7500

Water/EMI seal for doors

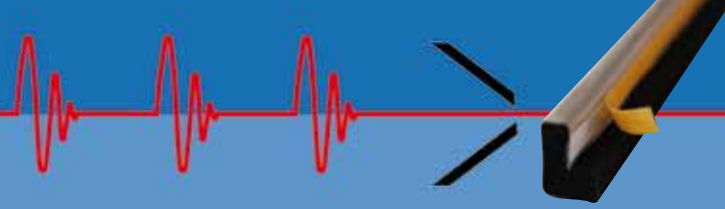

L-shape gasket with self-adhesive

L-shape gaskets

The L-shaped gasket was developed to create an efficient, combined seal for doors and lids. This gasket is used to achieve two goals at the same time: a water seal and an EMI seal.

This gasket is made from a seamless piece of neoprene foam. One side has been laminated with conductive textile or foil (the conductive side) and the other side is neoprene that provides a water seal.

The flange of the door will compress the water seal side of the gasket with very little force to realize a watertight seal. The electricity conducting part on the other side of the gasket creates an electrical connection between the door and the leaf of the door.

Benefits

- Bends easily around sharp corners without interrupting the water seal.
- Excellent water sealing up to IP65 (depending on construction).
- Mounted easily with a self-adhesive strip.
- Easy to use with small doors and lids.
- Low closure force to prevent bending of doors and lids.

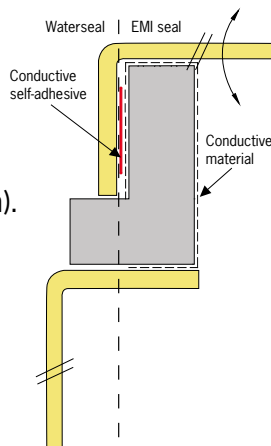

Options

- Custom made in the desired dimensions
- Available in flame retardant version
- Available with conductive self adhesive
- Available with chemical resistant rubbers like EPDM
- Silicone sponge for high temperatures up to 220°C
- Different conductive materials to prevent galvanic corrosion

Standard dimensions

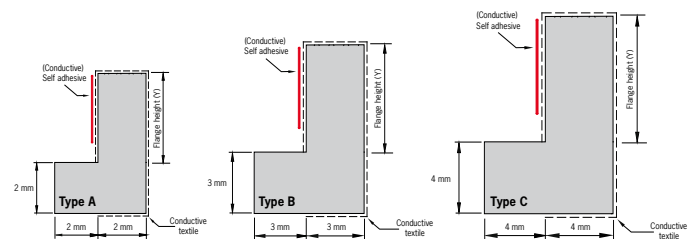

Flange height Y (mm)	Type A	Type B	Type C
	Small	Medium	Large
3	7503-S		
4	7504-S	7504-M	
6	7506-S	7506-M	
8	7508-S	7508-M	7508-L
10	7510-S	7510-M	7510-L
12	7512-S	7512-M	7512-L
14	7514-S	7514-M	7514-L
16	7516-S		7516-L
18	7518-S		7518-L
20	7520-S		7520-L

Shielding performance

Shielding Performance		
Frequency Hz	Mode	Screening in dB
1 Mhz	E	121 dB
10 Mhz	E	110 dB
100 Mhz	E	103 dB
400 Mhz	E	98 dB
1 Ghz	P	93 dB
10 Ghz	P	90 dB

See guarantee

Example

L-Shape gasket 7500, medium 6 mm flange, with conductive textile (T)



Part number	Flange Height (mm)	Cover
7500	6	T
	Specify the flange height in mm.	T: Conductive textile A: Amucor foil

Miniature shield 1400

Very small EMI gaskets

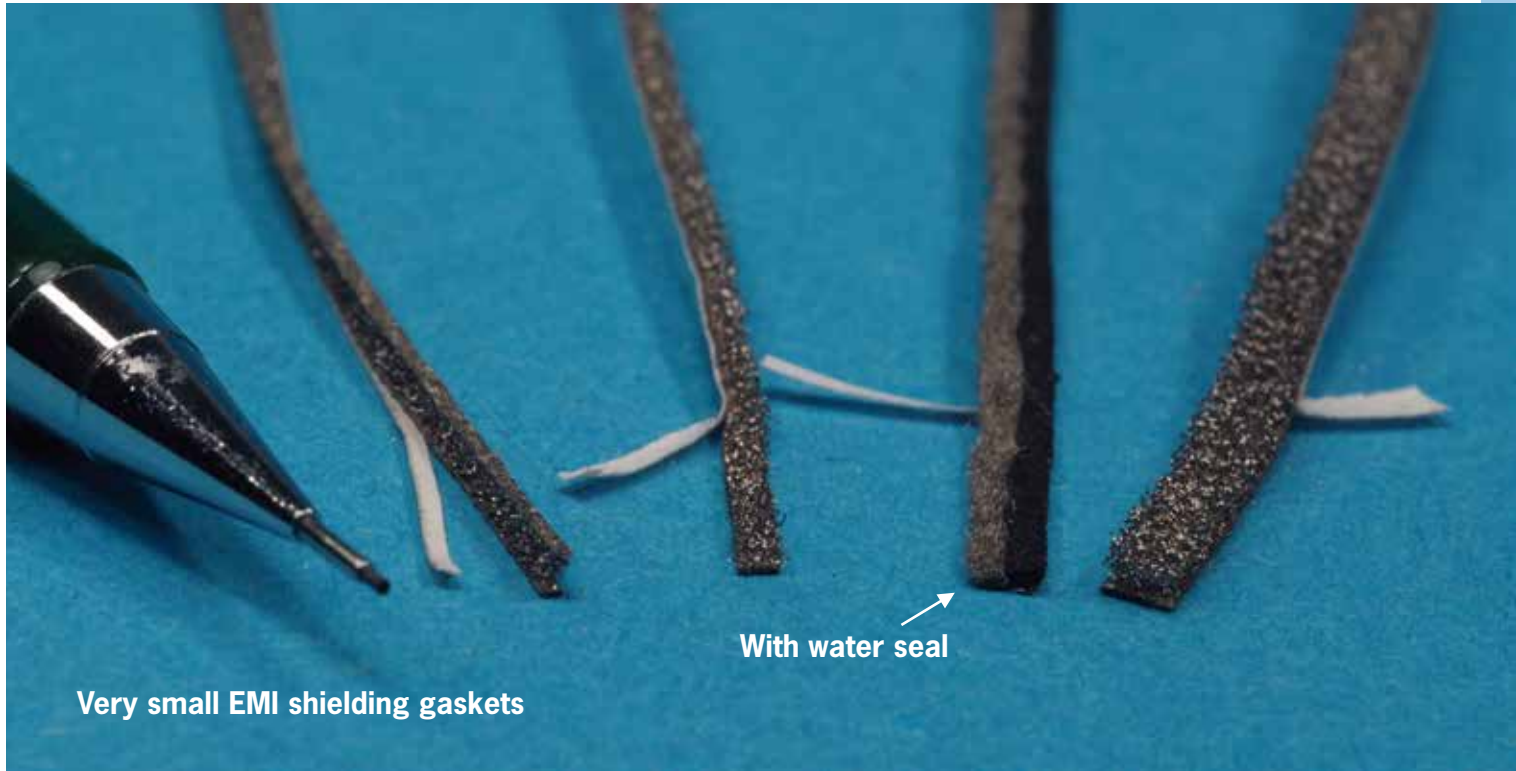

Very small EMI shielding gaskets

Miniature shield

This gasket can be produced in such small widths that the height exceeds the width. Application: on PCB and other products where there is very little space available and low compression force is required.

The material is a highly conductive foam with or without a conductive self-adhesive strip at the bottom. The foam can be compressed by even more than 50 % of its original height.

The smallest width is 1 mm and the maximum height is 6 mm. Roll lengths up to 100 meters.

Dimensions

Height Y (mm)		Width X (mm)						
		1,0	1,5	2,0	2,5	3,0	3,5	4,0
1,0	141015	141515	142015	142515	143015	143515	144015	
2,2	141022	141522	142022	142522	143022	143522	144022	
3,4	141034	141534	142034	142534	143034	143534	144034	
5,0	141050	141550	142050	142550	143050	143550	144040	
6,0	141060	141560	142060	142560	143060	143560	144060	

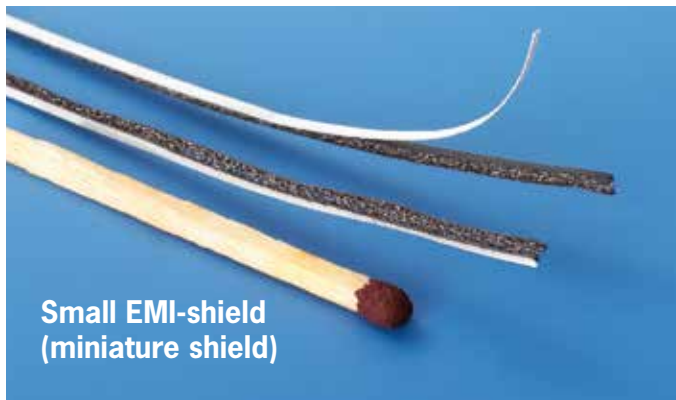

Small EMI-shield (miniature shield)

Options

- With water seal
- Resistant to high temperatures
- With cooling holes
- With or without self-adhesive

Ordering information

Example

Miniature shield 1400, 1.5 x 2.2 mm, made of conductive foam, with conductive self-adhesive and without waterseal.

Part number	Width	Height	Material	Waterseal	Adhesive
14	15	22	F	N	PSA
			F: Conductive foam R: Conductive rubber	S: Standard waterseal N: No waterseal	Specify (PSA) if you need conductive self-adhesive.

Clip-on shield 6500

Easy to mount clip-on EMI gasket with water seal

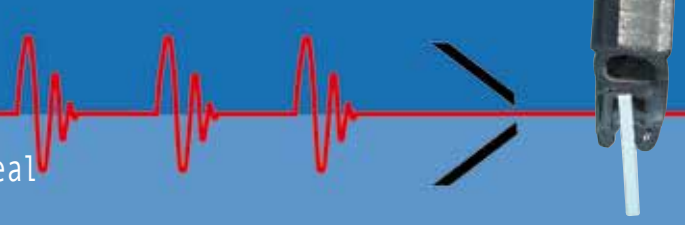

Clip-on EMI gaskets with water seal



This range of easily mounted clip-on gaskets is composed of a separate sponge rubber water seal and an EMI-shielding side of highly conductive, wear-resistant metallized fabric. The construction is very flexible thanks to the hollow rubber, so a low closure force is guaranteed.

The gasket is assembled without tools, simply by pressing the section by hand onto the metal flange of your enclosure.

The gasket can be angled in two planes where a small radius is sufficient. Temperature range from -40°C to +110°C. A flame retardant version (UL94 V0) is also available (seen in the picture above).

Shielding Performance

Frequency Hz	Mode	Screening dB
1M	E	121
10M	E	110
100M	E	103
400M	E	98
1G	P	93
10 G	P	90
See Guarantee		

Shielding effectiveness depends on surface, shape of gaskets and material used.



Dimensions

6590 Big clip-on shield	6585 Small clip-on shield	6595 Side clip-on shield

Different sizes and shapes are available on request.



Ordering information

Please indicate the profile number followed by the length in meters.

Profile

6585

6585 Small clip-on shield
6590 Big clip-on shield
6595 Side clip-on shield

Length (m)

10

Please specify the length in meters

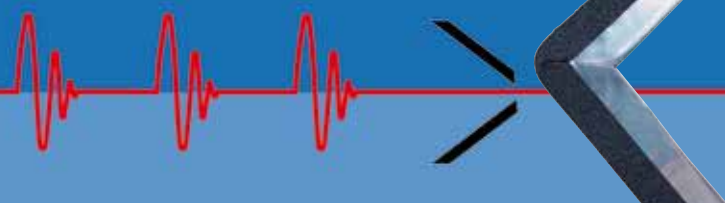

Water sealing EMI gaskets for screwed applications like panels, displays and windows 7300 A

The 7300 series EMC / IP gaskets are cost-effective combinations of an EMI shielding gasket and a water seal. This product comes with a self-adhesive strip.

The gasket consists of two neoprene foam cores, one of which is covered with reinforced foil, based on the high performance Amucor alloy. Amucor is compatible with aluminium and zinc plated steel. For aluminium with a chrome or stainless steel it is better to use highly conductive textile. The two parts can deflect independently to guarantee optimal shielding and sealing performance. Sharp inside corners can be made easily, without interrupting the water seal. For special applications, different foam cores are available as well as conductive foils and fabrics.

Dimensions

Height Y (mm)	Width X (mm)									
	4	6	8	9	10	12	15	18	20	25
1	7341	7361	7381	7391	73101	73121	73151	73181	73201	73251
2	7342	7362	7382	7392	73102	73122	73152	73182	73202	73252
3	7343	7363	7383	7393	73103	73123	73153	73183	73203	73253
4	7344	7364	7384	7394	73104	73124	73154	73184	73204	73254
5	7345	7365	7385	7395	73105	73125	73155	73185	73205	73255
6	7346	7366	7386	7396	73106	73126	73156	73186	73206	73256
8	7348	7368	7388	7398	73108	73128	73158	73188	73208	73258
10		73610	73810	73910	731010	731210	731510	731810	732010	732510
12		73612	73812	73912	731012	731212	731512	731812	732012	732512
15			73815	73915	731015	731215	731515	731815	732015	732515
18				73918	731018	731218	731518	731818	732018	732518
20					731020	731220	731520	731820	732020	732520
25						731225	731525	731825	732025	732525

Item numbers in **bold** are 98% stock items. Other dimensions on request.

Benefits

- Bends easily around sharp corners without interrupting the water seal
- Excellent water sealing up to IP65 (depending on construction)

Construction

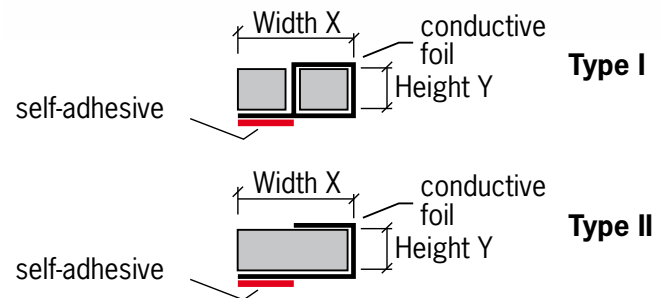
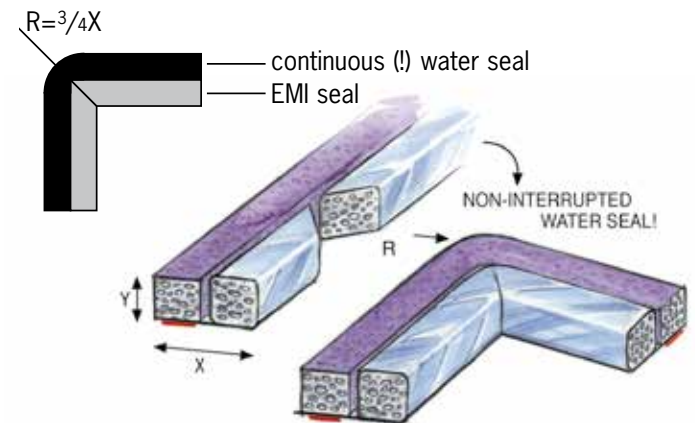

Shielding Performance

Frequency Hz	Mode	Screening dB	
		Amucor (A)	Conductive textile (T)
1M	E	121	115
10M	E	110	108
100M	E	103	102
400M	E	98	92
1G	P	92	90
10 G	P	89	87

See Guarantee

Shielding effectiveness depends on surface, shape of gaskets and material used.

Please specify your choice of **T (Textile)** or **A (Amucorfoil)**. Please indicate whether two separate parts are desired (**Type I**) or one piece (**Type II**).

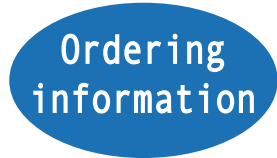

Example

Width X 10 mm, Height Y 5 mm with Amucor foil in two separate parts: **73-10-5-A-II**.

Series	Width (mm)	Height (mm)	Foil code	Type
73	10	5	A	II

A : Amucor
T : Conductive textile
Type I : Two pieces
Type II : One piece

O-profiles 7900

For application in grooves

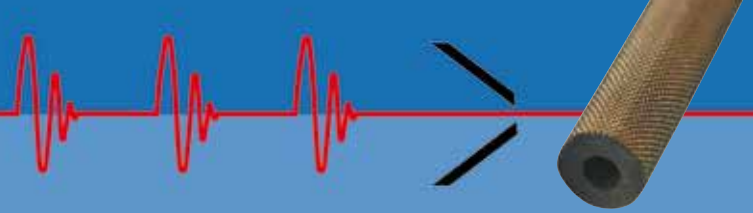

For applications in grooves

Several types of O-profiles have been developed for different applications, each with their own benefits. O-profiles were developed for high performance shielding, primarily for military applications. They are used where environmental and EMI screening is required but where little space is available.

Four kinds of cores are available: **solid, hollow extrusion, cell rubber and small rectangular shapes**. The rubber can be conductive or be covered with metallized fabric foil.

For optimal shielding performance a compression of 5-10% is recommended for solid elastomers and 10-50% for hollow extrusions and cell rubbers.

How to use

Solid elastomers are hardly compressible. They are easily deformed but their volume does not change as with sponge elastomers (PVC, EPDM, Neoprene) (see picture below). Therefore, allowance for material flow must be considered in the groove design.

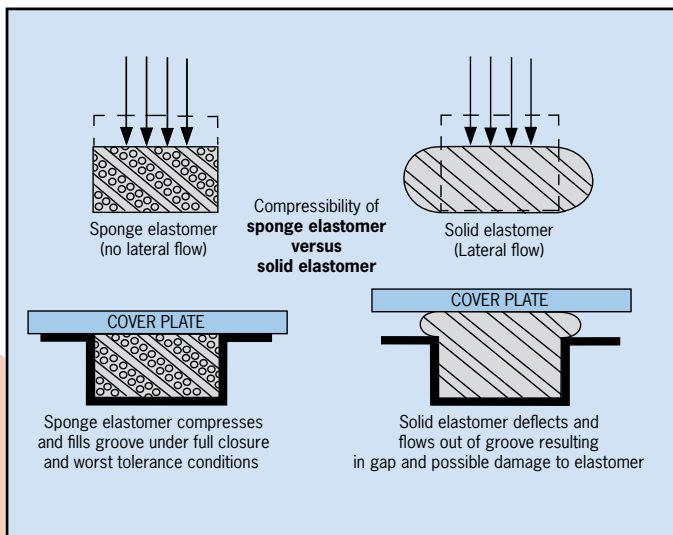

The figure below shows the design for two different types of grooves: on the left a typical rectangular groove, while the design on the right can mechanically retain circular cross section gaskets by side friction.

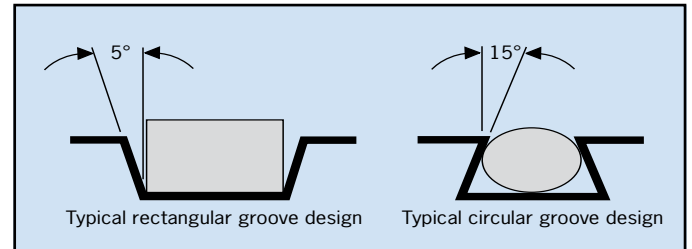

Shielding performance

Shielding effectiveness depends on surface, shape of gaskets and materials used.

Shielding performance (dB)					
Frequency	Graphite filled	Nickel filled	Silver filled	Conductive fabric	Amucor foil
200 KHz	70	75	70	65	70
100 MHz	95	110	115	103	110
500 MHz	90	110	115	92	98
2 GHz	90	105	115	89	91
10 GHz	90	100	115	87	89

See guarantee

Technical specifications of solid elastomers

Filler	Graphite	Nickel	Silver
Upper operating temp. C°	+160	+160	+160
Lower operating temp. C°	-50	-50	-50
Specific gravity (±5%)	1.99	4.60	3.20
Hardness shore A (±5%)	60	80	75
Elongation % (min)	100	100	100
Compression set %	30	30	30
Tensile strength Mpa (min)	1.00	1.25	1.25
Volume resistivity Ohms/cm (Max)	0.1	0.005	0.002

Benefits

- Easy to fit into grooves
- Deflection up to 50%
- Low closure force

Options

- Cut into accurate lengths or endless O-rings
- Drop out prevention fixtures
- UL94V-0 flame retardant core
- Silicone core for high temperatures up to 220°



O-profiles 7900

For application in grooves



Solid and hollow conductive O-rings and profiles

Standard dimensions Profiles

Hollow	Solid	Cell Rubber	Rectangular max. length \pm 300 mm
0.3 x 0.9	1.0	2.1	0.25 x 1
0.5 x 1.2	1.4	3.0	0.25 x 1,5
0.5 x 1.6	1.6	3.5	0.25 x 2
0.7 x 1.9	1.8	4.0	0.25 x 2,5
1.5 x 2.6	2.0	4.5	0.25 x 3
1.5 x 3.1	2.4	5.0	0.5 x 1
1.5 x 3.6	2.6	5.5	0.5 x 1,5
2.0 x 4.1	2.8	6.0	0.5 x 2
2.4 x 0.8	3.0	6.5	0.5 x 2,5
3 x 5	3.5	7.0	0.5 x 3
3.2 x 1.1	4.0	7.5	0.8 x 1
4 x 6	5.0	8.0	0.8 x 1,5
6 x 3.2	5.4	8.5	0.8 x 2
6 x 8	6.0	9.0	0.8 x 2,5
7 x 10	7.0	9.5	0.8 x 3
8 x 12	8.0	10.0	1 x 1
9.5 x 6.4	9.0	11.0	1 x 1,5
12 x 15	10.0	12.0	1 x 2
12 x 16	11.0	15.0	1 x 2,5
16 x 20	12.0	18.0	1 x 3
	15.0	20.0	1,5 x 1
	18.0	22.0	1,5 x 2
	20.0	25.0	1,5 x 3

Standard dimensions jointed O-rings

A mm	B mm
14.00	1.8
17.2	1.8
18.8	1.8
20.4	1.8
21.9	1.8
25.1	1.8
28.3	1.8
31.5	1.8
34.7	1.8
37.8	2.6
41.0	2.6
44.1	2.6

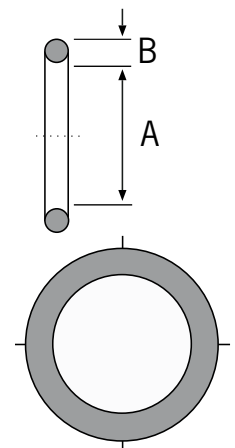

Ordering information

Example

Height Y 5mm, Width 10 mm with Hollow silicone O-profile covered with conductive fabric, diameter 1.5 x 2.6 mm: **79122-1.5 x 2.6**

Part number	Extrusion type	Base material	Covering	Dimensions in mm.
79	1	2	2	1.5 x 2.6
	1: Hollow 2: Solid 3: Sponge rubber 4: Rectangular 5: Jointed o-ring	1: Neoprene 2: Silicone 3: PVC 4: EPDM 5: Conductive rubber	1: Reinforced Amucor 2: Conductive fabric 3: Silver filled rubber 4: Nickel filled rubber 5: Graphite filled rubber	See the dimensions table for the possible dimensions by the chosen extrusion type

Ultra soft twin shield 7800

Low closure force EMI/IP gasket

innovative
EMI shielding
solutions

For doors:
low closure force
to prevent bending

Ultra Soft Shield Twin 7800 is a combined HF gasket / water seal with very low closure force. All gaskets are provided with a self-adhesive strip on the water seal side.

Ultra Soft Twin Shield 7800 consists of an HF gasket (compare Ultra Soft Shield 7400) combined with an environmental seal of closed-cell foam rubber.

The standard material for the water seal is neoprene foam. As an alternative a slowly recovering PVC foam, which is fully watertight at 30% compression is available.

Shielding performance

Frequency Hz	Mode	Screening dB
1M	E	115
10M	E	108
100M	E	102
400M	E	92
1G	P	90
10G	P	87

See Guarantee

Shielding effectiveness depends on surface, shape of gaskets and material used.

Dimensions

Z	X	Y	Part number
2 mm	4 mm	4 mm	7864
3 mm	6 mm	6 mm	7896
3 mm	9 mm	6 mm	78126
3 mm	9 mm	9 mm	78129
4 mm	12 mm	12 mm	781612

Other dimensions on request

Please specify the dimension code from the table above, followed by the code for the tape and the code for the material of the water seal.

Ordering
information

Example

Ultra Soft Twin shield 7800, 2+4 x 4mm, standard self-adhesive, with Neoprene foam water seal: **7864-01-N**

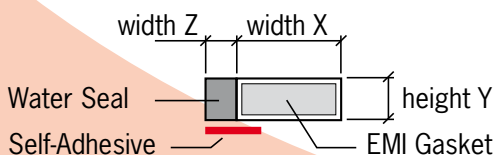
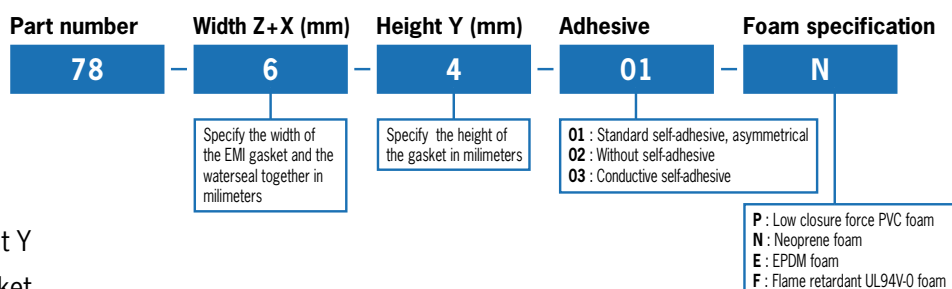

Customized gasket 8800

Any size and shape, EMI/IP gasket



A new CNC extrusion system has been developed to manufacture EMI shielding gaskets in a wide range of shapes and dimensions. With this system there are no tooling costs, so it is also interesting for smaller quantities or special constructions. The metal clad flame retardant gasket can be manufactured in several rigidities and is very compatible with aluminum, zinc-plated steel, Aluzinc, stainless steel, copper, etc.

Enclosures can be constructed more cost-effectively and compactly and the (electrically conductive) self-adhesive strips will reduce production time. The material is non-toxic and is an excellent replacement for the environmentally polluting beryllium gaskets.



Any size you want!
Customised gasket production in any size and shape

Available in dimensions from 1.7 - 30 mm, with or without separate water seal. The gaskets can be supplied in lengths according to customer specifications. Standard shapes are available for 19" racks, watertight enclosures and PCB shielding.

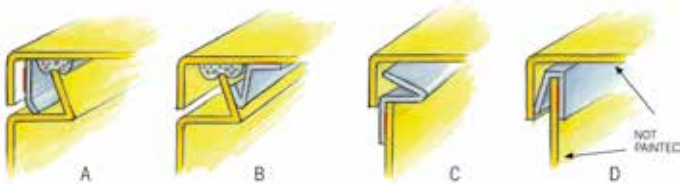
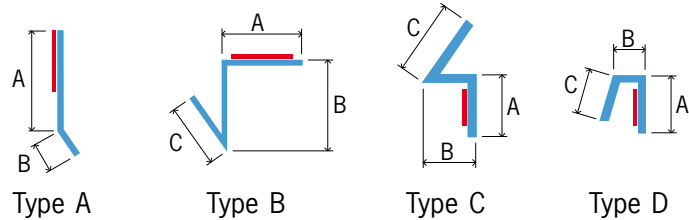

Some usual customized gasket 8800 shapes

Standard partnumbers

Type A			Type B			
Part no.	A	B	Part no.	A	B	C
8800-A-10-7	10	7	8800-B-15-15-12	15	15	12
8800-A-8-4	8	4	8800-B-10-10-7	10	10	7
8800-A-6-3	6	3	8800-B-8-8-5	8	8	5
8800-A-4-2	4	2				

Other dimensions on request

Type C			Type D				
Part no.	A	B	C	Part no.	A	B	C
8800-C-15-12-15	15	12	15	8800-D-15-2,5-15	15	2,5	15
8800-C-10-8-10	10	8	10	8800-D-12-2-10	12	2	10
8800-C-8-6-8	8	6	8	8800-D-8-1,5-8	8	1,5	8
8800-C-6-4-6	6	4	6	8800-D-6-1-6	6	1	6

Other dimensions on request

Shielding performance

Frequency Hz	Mode	Screening dB
1M	E	115
10M	E	108
100M	E	102
400M	E	92
1G	P	90
10G	P	87

See Guarantee

Shielding effectiveness depends on surface, shape of gasket and material used.

Options

- Cut into accurate lengths
- Combination with water seal
- UL94V-0 compliant
- Chemical resistant versions
- Resistant to high temperatures
- Different conductive foils and fabrics

Benefits

- No tooling costs
- A wide range of shapes
- Self-adhesive gasket
- Easy to fit
- Small dimensions
- Very high deflection
- Low closure force

Example

Customized gasket 8800, type b, 15, 15, 12 mm made of conductive textile.

Ordering information

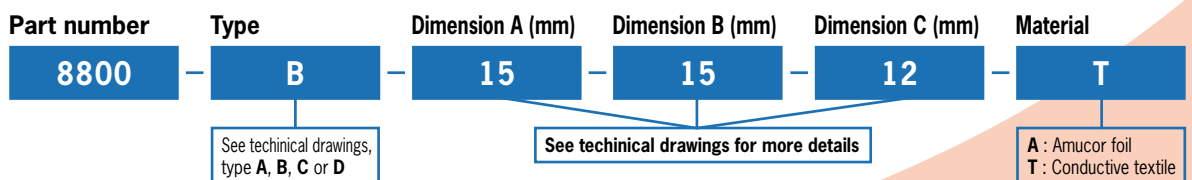

Die-cut gaskets 8300

Gaskets die-cut according to the client's drawing

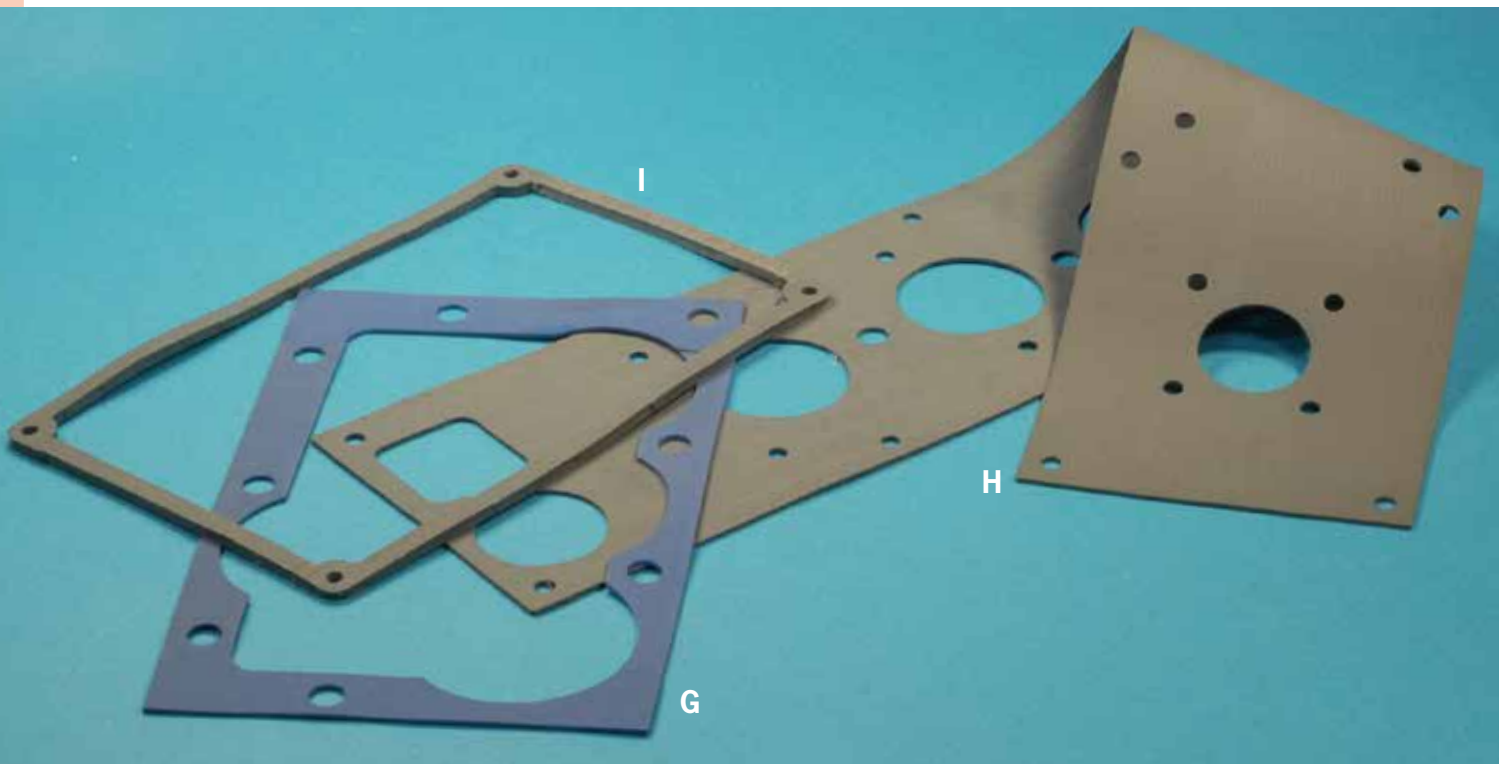
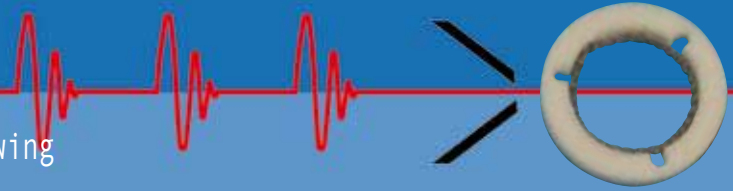

Die-cut gasket EMI/IP

Any shape, prototype service

Gaskets made out of conductive rubber are quite expensive and also not as soft as designers tend to prevent bending and leakage. Therefore we have developed gaskets which provide the same functionality. Some examples:

- A** : Self-adhesive neoprene gasket with knitted mesh inside.
- B** : Very small gasket with inserts of conductive foam.
- C** : Small gasket with insert of conductive hollow round rubber profile.
- D** : Flash-cut gasket with knitted mesh.
- E** : Flash-cut gasket.
- F** : Outside neoprene with conductive foam inside.

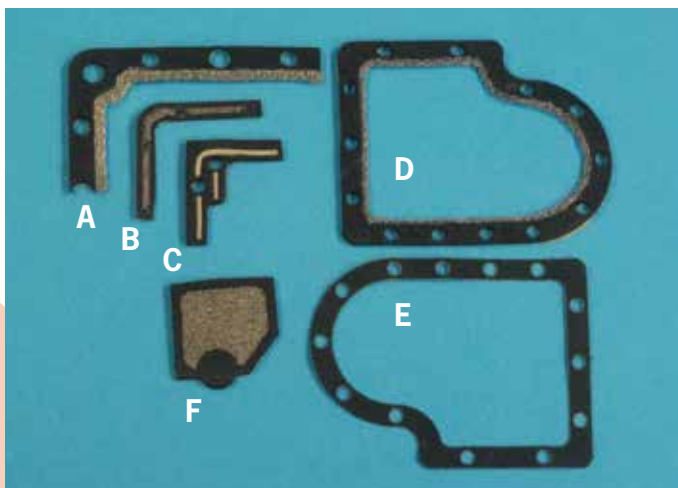

- G** : Fluor silicone gasket with Monel wires
- H** : Flash-cut gasket with silicone sponge with aluminium wires
- I** : Silicone gasket with Monel in welded construction.

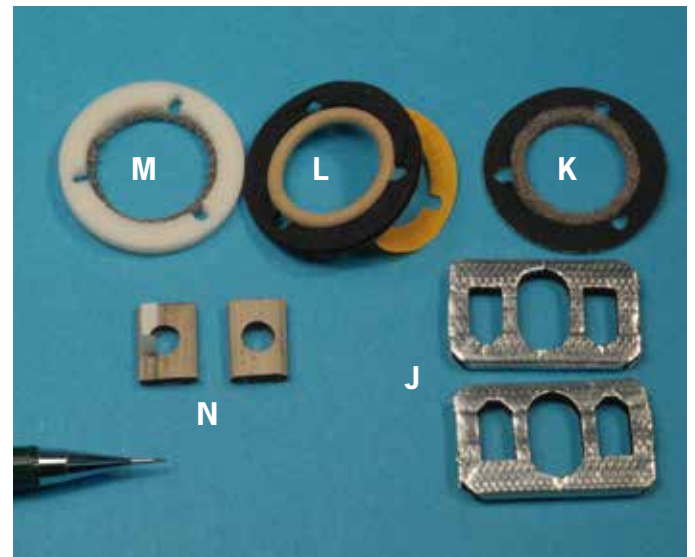

- J** : Die-cut gasket from profile (embossed Amucor foil)
- K** : Round closed cell neoprene gasket with soft conductive foam inside
- L** : Neoprene gasket with conductive rubber hollow o-ring profile
- M** : Silicone foam gasket with mesh foil inside
- N** : Fabric over foam gasket profile with asymmetric tape

Frame gaskets 8100

For panels and screwed applications



Self adhesive
Frame Gasket

Frame Gasket 8100

For panels and screwed applications like displays, windows and honeycomb vents.

The 8100 series frame gaskets are ready-made gaskets according to customer specifications. They have reinforced corner pieces to guarantee optimum shielding performance and easy mounting characteristics.

The standard base material is Amucor-shield 6800 or EMC/IP gasket 7300.

Disc or washer-type compression stops can be included to prevent overcompression. 8100 series endless gaskets can also be supplied with an additional water seal.

Shielding Performance

The shielding performance depends on the chosen outer material. Amucor-shield 6800 has reinforced Amucor foil while Ultra Soft Shield 7400 has conductive fabric covering.

Benefits

- Easy mounting
- High shielding performance
- No tools required
- Dimensions up to 2 x 2 m

Compression stops

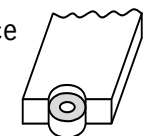

WASHER TYPE
used at bolt holes

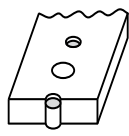

DISK TYPE
used beside bolt holes

Endless Gasket 8000

Combined EMI / Water seal for grooves

The 8000 series endless gaskets are suitable for many applications in which both an EMI shielding gasket and a water seal are required. The 8000 series endless gasket consists of a rectangular EMI gasket (Amucor-shield 6800 or Ultra Soft Shield 7400), combined with a closed-cell water seal. All gaskets can be provided with a self-adhesive strip for easy mounting.

Gasket materials for the 8000 series endless gaskets are watertight at 30% compression, depending on the construction

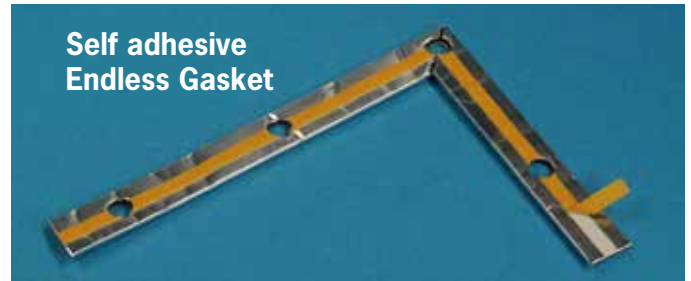

Self adhesive
Endless Gasket

Options

- UL94V-0 flame retardant foam core
- chemical resistant rubbers like EPDM
- silicone sponge for high temperatures up to 220°C
- available in textile, Amucor or mesh

Pre-produced die-cut strips

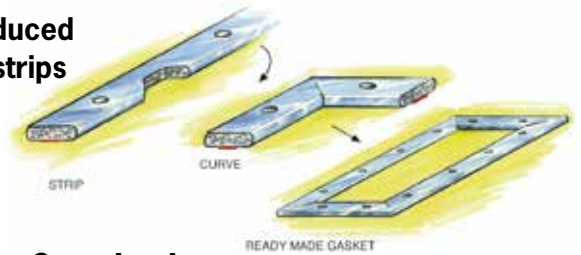

Drawing Standards

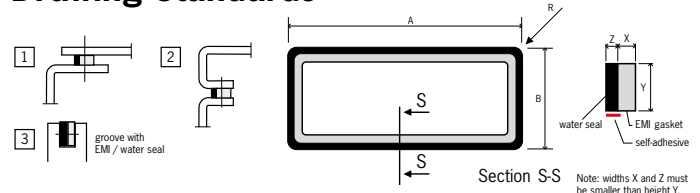

When ordering, specifications should include: gasket material, water seal material, drawing, with or without self-adhesive and quantity.

Ordering information

Part number	Material (core)	Material (waterseal)	Adhesive	Drawing
8000	N	N	01	
8000 : Combined EMI/IP gasket Amucor 8001 : Combined EMI/IP gasket conductive textile 8100 : Frame gasket Amucor 8101 : Frame gasket conductive textile	N : Neoprene P : Low closure force PVC foam E : EPDM F : Flame retardant UL94V-0 foam S : Silicone foam	N : Neoprene S : Silicone	01 : Standard self-adhesive 02 : Without self-adhesive 03 : With conductive self-adhesive	Please your drawing or drawing no.

Oriented wire shield 5711-5722

Sheet material to die-cut into complex shapes

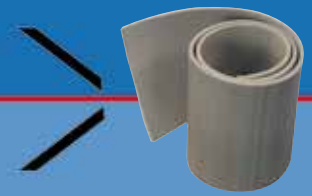

Technical specifications

Colour:	Grey silicone
Elastomer:	Silicone or fluorosilicone
Conductive filler:	Monel wire, aluminium wire
ROHS compliance:	Yes
Corrosion resistance:	Yes
UV resistance:	Yes
Oil resistance:	Fluorosilicone type only
Fuel resistance:	Fluorosilicone type only
IP rating:	Yes

Material	Solid silicone with Monel wire 5711	Solid silicone with aluminium wire 5712	Solid fluorosilicone with Monel wire 5713	Sponge silicone with Monel wire 5721	Sponge silicone with aluminium wire 5722
Color	Grey	Grey	Blue	Grey	Grey
Wire count/ sq.inch.	900	900	900	900	900
Compression set	25%	25%	25%	25%	25%
Closing force (psi)	25-100	25-100	25-100	5-50	5-50
Fuel/Solvent resistant	No	No	Yes	No	No
Temperature (C°)	-65/200	-65/200	-55/200	-65/200	-65/200

Shielding performance (dB)

Material	Solid silicone with Monel wire	Solid silicone with aluminium wire	Solid fluorosilicone with Monel wire	Sponge silicone with Monel wire	Sponge silicone with aluminium wire
200 KH	70	70	70	70	70
100 MHz	125	100	100	120	8
1.0 GHz	125	100	100	125	70

Benefits

- Temperatures up to 220°C
- High shielding performance
- Water sealing, up to depth of 10 meters
- Pressure resistant
- Salt spray / chemical resistant
- Fluorsilicone rubber for fuel/oil-resistance
- Supplied as sheets, strips or die-cuts

Oriented Wire Shield 5711 - 5722 is a composite gasket material consisting of a large number of small wires embedded and bonded in solid or sponge silicone, or fluor silicone elastomer for oil-resistance.

The wires provide excellent conductivity to establish EMI / RFI shielding.

The material is used in military, industrial and commercial products requiring EMI suppression, grounding, or static discharge. It is very suitable for applications where an environmental or pressure seal is required.

The sponge version is used where there is severe joint unevenness, or if lower closure forces and greater compressibility are required.

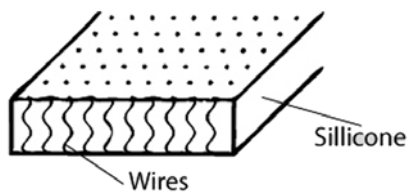

Dimensions

Standard sheet of 90 x 900 mm. Bigger items can be welded/joined together. This is to prevent waste of material.

Custom compositions are available on request- please send a drawing with dimensions to our email address.



Ordering information

When ordering Flatshield 5700, please specify part number and dimensions. For die cuts, please enclose a detailed drawing.

Series	Width (mm)	Length (mm)	Thickness
5711	50	50	081
5711 : Solid silicone with Monel wires 5712 : Solid silicone with aluminium wires 5713 : Solid fluorosilicone with Monel wires 5721 : Sponge silicone with Monel wires 5722 : Sponge silicone with aluminium wires			
Available thicknesses 0.81, 1.13, 1.38, 1.57, 2.40, 3.18, 3.96, 4.78, 6.35 mm. Other thicknesses on request.			

Conductive Felt 5730

Non woven texture polyester with nickel coating

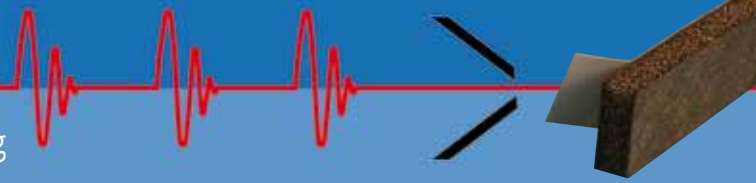

Non woven texture polyester with nickel coating.
Thickness 1.5 mm.

Maximum width : 500 mm.
Nickel coating : 35 - 40 g/m².

Options

With or without conductive adhesive.

Specification

Partnumber	5730
Tensile strength (length of roll)	>=230 N/5cm
Tensile strength (crosswise)	>=340 N/5cm
Weight	150 g/m ²
Thickness	1,5mm
Breaking charge (Longitudinally)	>=230 N/5cm
Breaking charge (Trasversely)	>=340 N/5cm
Max. elongation	>=55%
Flame resistance	UL 94 HB



Shielding performance

Magnetic field H 0 - 30 MHz		Magnetic field E 01 MHz - 30 MHz				Plane wave 2GHz - 18GHz	
3MHZ	15dB	1MHZ	100dB	100MHZ	52dB	0,8GHz	67dB
10MHZ	25dB	5MHZ	75dB	150MHZ	50dB	0,9GHz	70dB
15MHZ	28dB	10MHZ	62dB	400MHZ	62dB	1,0GHz	70dB
20MHZ	32dB	20MHZ	60dB	500MHZ	65dB	10,0GHz	90dB
30MHZ	35dB	30MHZ	56dB	700MHZ	70dB	18,0GHz	70dB

See guarantee



Die-cut
conductive felt

Ordering information

When ordering conductive felt 5730, please specify part number and dimensions. For die cuts, please enclose a detailed drawing.

Example

For example conductive felt (5730) 400 x 400 mm:

Series	Width (mm)	Height (mm)
5730	400	400
	Maximum width 500 mm	

Conductive rubber 5750

Where less space is available / EMI-IP seal

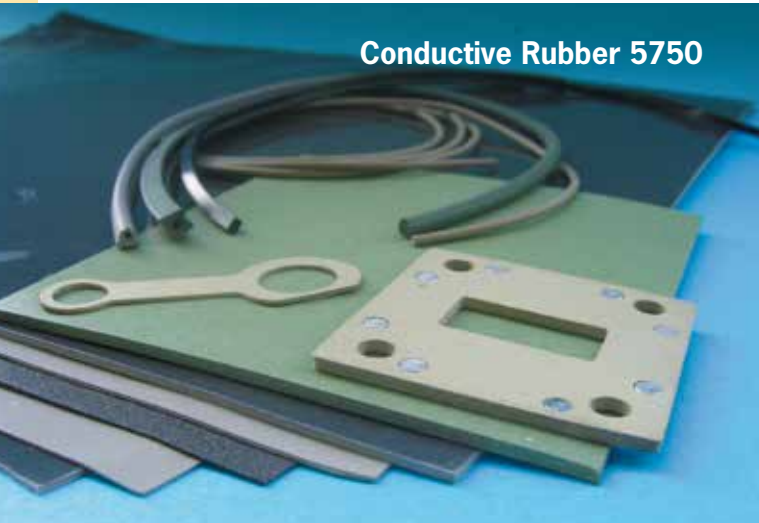
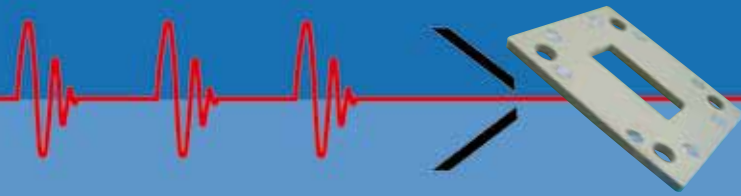

Conductive Rubber 5750

This conductive fabric is a rubber filled with small conductive metal parts to make it conductive.

This heat-proof silicone conductive rubber can create an EMI-proof and watertight seal in narrow constructions. Also for protection against EMP and static electricity. Also available in fluorsilicone conductive rubber for resistance against (hydraulic) oils and fuels. The rubber can be filled with silver, nickel, silvered glass, silvered aluminum or graphite (only for ESD). Also for wave-guide applications.

As it shields high frequencies, conductive rubber offers a shielding effect of 60 dB at 30MHz ~ 10GHz. Owing to its excellent conductivity, grounding and shielding effect, it is well suited for military communication equipment. It can be manufactured in various shapes such as sheets, moulded parts, die-cut, strips, o-rings, etc.

Profile sizes

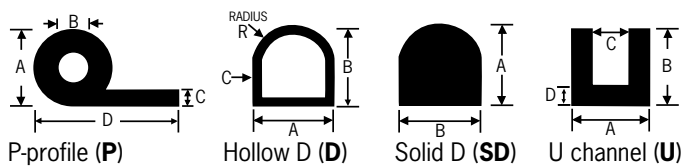

P-profile (P)				
A (mm)	B (mm)	C (mm)	D (mm)	Size number
5.0	2.0	1.6	12.7	50-20-16-127
5.0	2.0	1.6	21.6	50-20-16-216
6.4	3.2	1.6	12.7	64-32-16-127
6.4	3.2	1.6	15.9	64-32-16-159
6.4	3.2	1.6	22.2	64-32-16-222
7.9	4.8	1.6	22.2	79-48-16-222
9.1	6.5	1.8	19,8	91-65-18-198

Hollow D (D)				
A (mm)	B (mm)	C (mm)	R (mm)	Size number
4.0	4.0	1.1	2.0	40-40-11-20
4.8	4.7	1.3	2.4	48-47-13-24
6.4	6.4	1.7	3.2	64-64-17-32
7.9	7.9	1.3	4.0	79-79-13-40
7.9	7.9	1.6	4.0	79-79-16-40
12.4	8.2	2.0	6.2	124-82-20-62

Solid D (SD)		
A (mm)	B (mm)	Size number
1.6	1.4	16-14
1.7	1.6	17-16
2.0	2.4	20-24
2.3	2.0	23-20
2.5	1.6	25-16
2.8	3.2	28-32
3.4	3.1	34-31
4.0	3.0	40-30
4.5	4.5	45-45
4.8	4.8	48-48
6.4	6.4	64-64

U channel (U)				
A (mm)	B (mm)	C (mm)	D (mm)	Size number
2.4	2.5	0.9	0.8	24-25-09-08
3.2	2.8	0.7	1.3	32-28-07-13
3.2	5.7	0.5	1.9	32-57-05-19
4.0	4.0	1.6	1.2	40-40-16-12
4.5	4.0	1.2	1.9	45-40-12-19
8.3	6.0	1.6	2.9	83-60-16-29

Benefits

- Excellent conductivity throughout the surface
- Excellent electromagnetic shielding effect
- Easy die-cutting, kiss-cutting and slitting
- Temperature range -60 to +220 °C

Technical properties

Typical properties	5750	5760
Filler	Ag/Cu	Ni-Graphite
Base polymer	Silicone	Silicone
Width (mm)	210 x 300 (Larger sizes on request)	
Thickness (mm)	0.2 to 3 (thicker on request)	
Elongation, %, min.	90	50
Flame resistance, UL94 (horizontal)	HB	HB
Flame resistance, UL94 (vertical)	V-0	V-0
Volume resistance, Ohm-cm (expression of conductivity)	0.2	0.2
Hardness		
Shore A:	40	30
Shore OO:	85	80
Tensile strength, psi, min.	90	50
Shielding performance (dB)		
100 MHz	120	100
500 MHz	120	100
1 GHz	110	110
10 GHz	85	85
See guarantee		

Other material options (on request):

- Fluorosilicone with nickel graphite particles (fuel resistant)
- Silicone with nickel particles for aluminium parts
- Fluorosilicone with nickel particles
- Silicone with nickel plated aluminium particles
- Fluorosilicone with silver plated aluminium particles

Available as:

- Sheets • Moulded parts • Die-cut, or flash cut • Strip

Example

For **Ag/Cu Silicone** conductive rubber, as a sheet (S), thickness 0.5 mm, dimensions 50 x 250 mm, use part number: **5750-S-050-50-250**

Ordering information

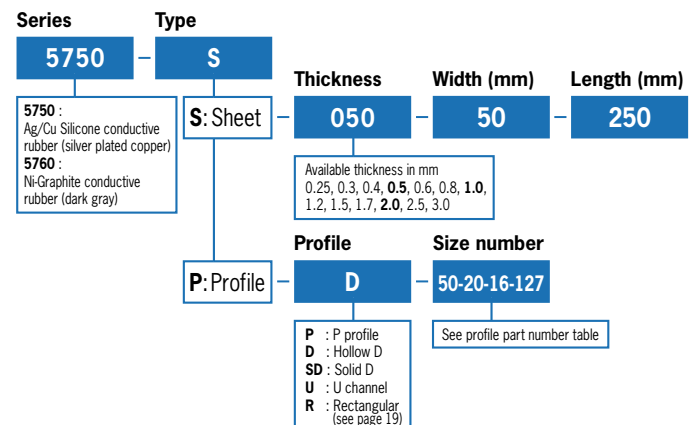

Conductive foam 5770

EMI shield, low closure force, in any shape

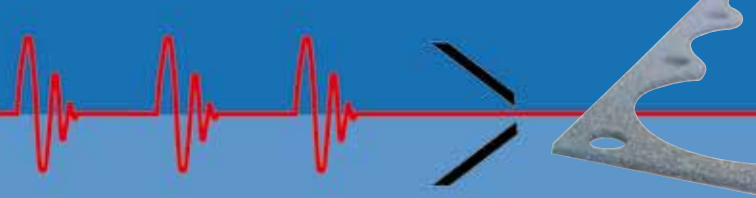

This conductive foam is made of polyurethane foam plated with copper and nickel. Compression is 25% to 75%. It will return nearly to nominal height when released. It is coated with conductive polyurethane to protect the foam from the environment and to prevent burrs when cutting. The conductivity is excellent in all directions X, Y and Z. It is flame retardant and RoHS compliant.

The conductive foam is characterized by:

- Availability in thicknesses of - 1, 2, 3, 4 and 5 mm, (Other sizes on request).
- Excellent electric conductivity throughout the surface across the thickness
- Excellent electromagnetic shielding effect
- High workability for adhesion
- Easy die cutting, kiss cutting and slitting
- Size - Sheet Type: Max 450 x 450 mm, (Other sizes on request).

Applications

- Mobile phone
- Noise filter core
- Cable tray
- Shielded rooms

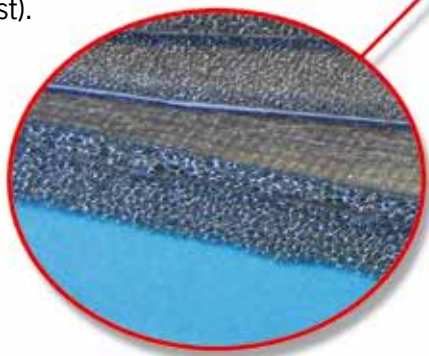

Technical data

Item	Data
Thickness (mm)	1 to 5 mm
Color	Gray
Adhesive strength (gf/25mm)	>1,000
Holding strength (sec)	>3,600
Surface resistance (Ω /sq)	<0,2
Surface resistance (Ω /in)	1.0 max
Top-bottom resistance (Ω /in)	1.0 max
RoHS	Compliant
Fire retardant (cm/min)	Pass

Specifications and partnumbers

Product Number	Material (base/material)	Thickness (mm)	Surface resistivity (Ω /sq)	Volume resistivity (Ω /sq)
57715	PET+PU / Cu+NI	1.5	0.2	0.2
57722	PET+PU / Cu+NI	2.2	0.2	0.2
57734	PET+PU / Cu+NI	3.4	0.2	0.2
57750	PET+PU / Cu+NI	5.0	0.2	0.5
57760	PET+PU / Cu+NI	6.0	0.2	0.5

Material

- Mesh: Woven Polyester, copper and nickel plated
- Conductive foam: Polyurethane foam (Copper and nickel plated)
- PSA: Acrylic exter polyol copolymer + nickel powder
- PU Coating: Polymer resin (Polyurethane)
- Release liner: CP paper avg 150 μ m

Benefits

- With or without self-adhesive
- Supplied as sheets, strips or die-cuts
- With water seal
- Resistant to high temperatures, with cooling holes
- Reinforced with non-woven fabric on 1 or 2 sides
- PSA Attachment Method Option
- Nickel/Copper Metallization
- X-Y-Z Axis Conductivity
- Tolerance of ± 0.5 mm
- I/O Static Applications/Gasket Replacement

When ordering conductive foam 5770, please specify part number and dimension.

For die cuts, please enclose a detail drawing.

Ordering information

Example

For example Conductive foam 1.5 mm thick:

Series	Thickness
577	15

Conductive transparent foil 9000

Easy way to make transparent shielded windows



Roll of mesh foil with flying mesh and ready made displays with a step and silver bus bar

The easiest way to create transparent shielded windows, from standard displays, glass, acrylic, polycarbonate or plexiglass.

Mesh foil

Mesh foil is easily applied to glass, acrylic and polycarbonate, by hand or with a laminator. Mesh foil is effective between 10 KHz and 30 GHz. To make a electrical connection with your housing/enclosure we deliver mesh foil with flying mesh on the sides or with a silver bus bar (see section: Styles). For small areas or when thin wires are not suitable we have transparent conductive coating (Page 45).

Light transmission

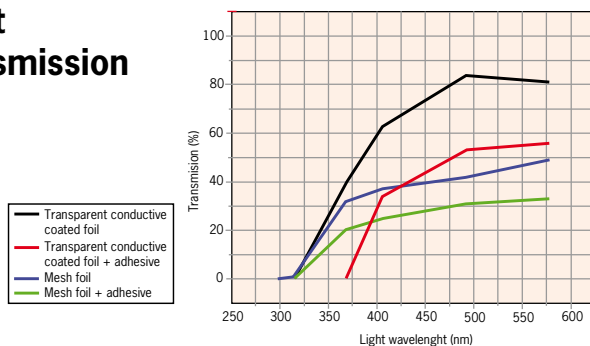

What is mesh foil?

Mesh foil is a very fine wire mesh, laminated between two layers of transparent PET foil. The wires are so fine that you can hardly see them. The foil is scratch resistant and bends very well.

Types

Mesh foil can be produced in various versions:

- Stainless steel
- Blackened copper (Standard)
- Phosphor bronze

Options

- Wires placed at custom angle to prevent moiré effect
- Placed on existing window
- Made of polycarbonate, acryl or glass
- With or without transparent self-adhesive



Mounting options

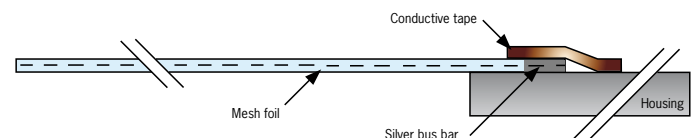

Standard mesh foil mounted with conductive tape 3201

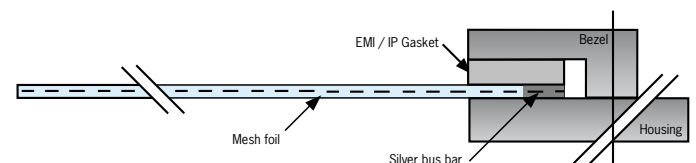

Standard mesh foil mounted by a clamping construction with an EMI gasket. A water seal is optional.

Conductive transparent foil 9000

Easy way to make transparent shielded windows

Styles

#1 As sheets or on rolls.

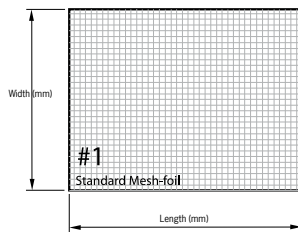

#2 As sheets or on rolls. Flying mesh on 2 sides to make a connection.

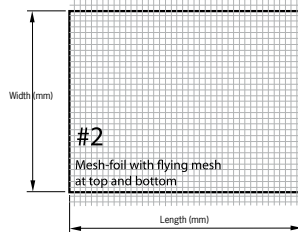

#3 Only as sheets. Flying mesh on all sides to make a connection.

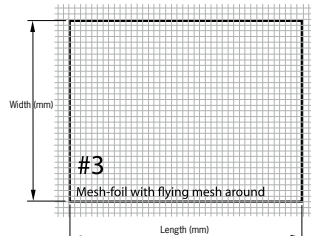

#4 Only as sheets. Silver bus bar at top and bottom to make a connection.

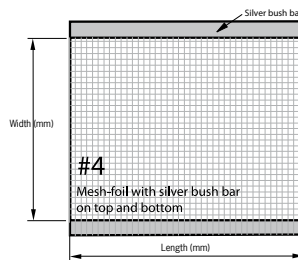

#5 Only as sheets. Silver bus bar around to make a connection.

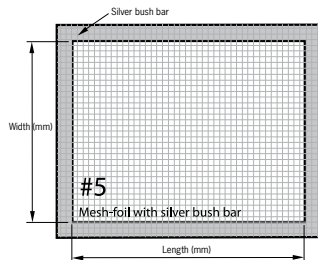

#6 Only as sheet. Silver bush-bar and flying mesh to make a connection.

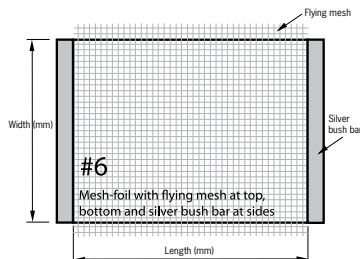

For small quantities, the most economical solution is style #1.

Technical details

Type (wires/inch)	100
Wire diameter (mm)	0.050
Nominal aperture (mm)	0.204
Light transmission %	64.5

*Mesh foil 100 OPI is our standard mesh foil; 70, 80 and 250 OPI on request

Shielding performance (100 OPI)

Field type	Frequency	dB
H	10 kHz	22
H	100 kHz	35
H	1000 kHz	54
E	1 MHz	111
E	10 MHz	99
E	100 MHz	95
P	1 GHz	72
P	10 GHz	45

See Guarantee

Standard part numbers

Size (mm)	Length (m)	Part number			
		standard mesh foil	standard + self adhesive	standard + scratch resistant layer	standard + scratch resistant layer and self adhesive
10	5	90-10-5000	91-10-5000	92-10-5000	93-10-5000
20	5	90-20-5000	91-20-5000	92-20-5000	93-20-5000
30	5	90-30-5000	91-30-5000	92-30-5000	93-30-5000
40	5	90-40-5000	91-40-5000	92-40-5000	93-40-5000
50	5	90-50-5000	91-50-5000	92-50-5000	93-50-5000
100	2	90-100-5000	91-100-2000	92-100-2000	93-100-2000
200	2	90-200-2000	91-200-2000	92-200-2000	93-200-2000
1000	roll	90-1000-XX	91-1000-XX	92-1000-XX	93-1000-XX

Example

Standard mesh foil laminated onto 3 mm thick polycarbonate, visible area 250x 300 mm, wires placed at 45 degrees and sheet style #3.

Ordering information

Series	Width (mm)	Length (mm)	Material	Thickness (mm)	Wire angle	Sheetstyle
91	250	300	P	3	45	#3

90 : Standard mesh foil
 91 : Standard mesh foil + Self-adhesive
 92 : Standard mesh foil + Scratch resistant layer
 93 : Standard mesh foil + Scratch resistant layer + Self-adhesive

(F) Foil PET 0.175 (other on request)
 (P) Polycarbonate (Standard 3mm/4mm)
 (A) Acrylic (Standard 2mm)
 (G) Glass (Standard 1.3mm/4mm)

Angle of the wire mesh in degrees. Standard is 0 degrees.

Specify the thickness in mm.

#1: Standard mesh foil
 #2: With flying mesh at top and bottom
 #3: With flying mesh on all sides
 #4: With silver bar at top and bottom
 #5: With silver bar on all sides
 #6: With flying mesh at top and bottom and silver bar left and right

Conductive Tapes 3200

At any width, with or without conductive adhesive



Conductive Tapes 3200

A large series of tapes, which are electrically conductive. Ideal for earthing, conductance and EMI shielding.

Metal Tape with conductive self-adhesive

Electrically conductive tapes can be cut to any width from 3 mm wide and can be delivered from stock. A width of 25 mm is used most commonly. Standard roll length 16.5 meters.

Applications

- Electrical connection between surfaces (sheets / foils)
- Die-cuts
- Mounting transparent foils, windows
- Shielding in housings
- Cable shielding
- Temporary shielding during tests (see page 36)
- Antistatic floor

Shielding effectiveness

Many factors determine the true effectiveness of a shielding tape when applied, including type and thickness of foil, adhesive type, closeness of contact, smoothness of application surface, strength and frequency of the EMI signal, etc. Still, an attenuation value can be determined using standard tests and fixtures.

For tape, typical shielding effectiveness (far field) is in the range of 60dB to 80dB (10 KHz to 20 GHz). For more specifications see table.

We can slice tapes in any width



3201 Copper tape with conductive adhesive

A soft metal foil with a highly conductive self-adhesive on one side, with a release liner.

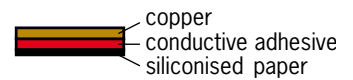

- Conductive acrylic adhesive
- Supplied with a removable liner for easy handling and die-cutting

The tape is standard available in:

- 0,035 mm (part no. 3201)
- 0,12 mm (part no. 3212)
- 0,18 mm (part no. 3218)
- Other on request

3202 Tinned copper tape

Like tape 3201 with added tin layer for corrosion protection and improved solderability.

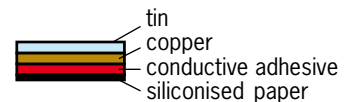

3203 Aluminium tape

Developed especially for aluminium housings and frames to prevent galvanic corrosion.

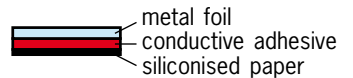

3204 Contact Surface Tape

A metal tape with a highly conductive self-adhesive on one side and masking tape on the other side.

This contact surface tape is used to improve the corrosion resistance of construction metals (like untreated steel plates), or to improve the galvanic compatibility when 2 metal parts are connected with a gasket. After the parts have been coated, the paint overlaps the metal tape to increase the bonding. For more specifications see table.

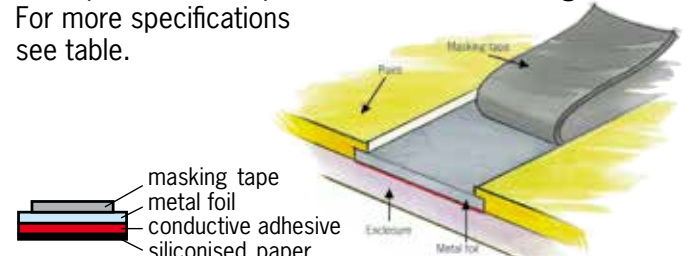

Conductive Tapes 3200

At any width, with or without conductive adhesive



3205 Mounting tape

A double-sided self-adhesive transfer tape for mounting purposes. This system can be applied much faster than a conductive glue and can be applied very accurately. No time required for curing (pressure sensitive version). For lower resistance and/or to fill gaps with a rough surface we recommend Shieldokit electrical conductive 2 components adhesive (see Conductive Glue page 42). For more specifications see table.

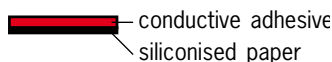

3206 Die-cut mounting tape/ Sandwich copper tape

A soft metal foil, laminated on 2 sides with a conductive self-adhesive. This is available in sheets and rolls. For more specifications see table.

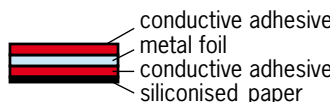

3207 Copper tape with paper insulation

Same as 3201 but with a paper layer added to insulate the top layer of the copper tape. Thickness of the copper is 0.035 mm with a 0.5 mm thick paper insulation layer. Available in 1500 mm width.

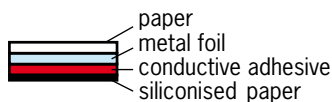

3208 Mu-ferro tape

Metal tape used for shielding against low magnetic frequencies.

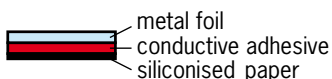

4703 Amucor tape

This is a 11 micron thick Amucor tape (Aluminium type), reinforced with 23 micron thick polyester and an acrylic adhesive on the back.

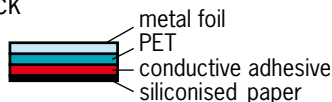

4713 Conductive textile tape

Nylon ripstop, extremely strong + flexible. Metalized with Cu/Ni with conductive adhesive on the back (see also 3205).

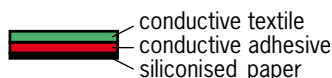

4718 Amucor with PET in the middle

Sandwich tape with 2 layers of 11 micron thick aluminium with 23 micron polyester inside.

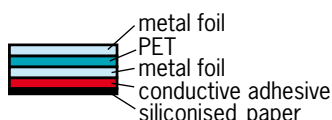

Technical specification and part numbers

part no. (Conductive adhesive)	3201	3202	3203	3204	3205	3206
part no. (Standard adhesive)	3301	3302	3303	3304	-	3306
construction						
foil material	soft copper	soft copper	aluminium	soft copper	-	soft copper
surface	shiny	tinned	shiny	shiny	-	-
foil thickness	0.035 mm	0.035 mm	0.040 mm	0.035 mm	-	0.035 mm
total thickness	0.060 mm	0.060 mm	0.065 mm	0.060 mm	0.050 mm	0.085 mm
adhesive	synthetic conductive resin	synthetic conductive resin	synthetic conductive resin	synthetic conductive resin	synthetic conductive resin	synthetic conductive resin
adhesive performance	4.5 N/cm	4.5 N/cm	4.5 N/cm	4.5 N/cm	4.5 N/cm	4.5 N/cm
tensile strength	55 N/cm	40 N/cm	25 N/cm	55 N/cm	-	55 N/cm
temperature resistance	155°C	155°C	155°C	155°C	155°C	155°C
el. resistance through adhesive	0.003 Ohm	0.003 Ohm	0.003 Ohm	0.003 Ohm	0.003 Ohm	0.003 Ohm
standard roll widths (mm)	10, 25, 50, 100	10, 25, 50, 100	10, 25, 50, 100	10, 25, 50, 100	10, 25, 50, 100	10, 25, 50, 100
roll lengths	16.5 m	16.5 m	16.5 m	16.5 m	16.5 m	16.5 m

Other roll lengths on request

part nr. (Conductive adhesive)	3207	3208	4703	4713	4718
part nr. (Standard adhesive)	3307	3305	4702	4712	4717
construction					
foil material	soft copper with paper	Mu-ferro	Amucor	Conductive textile	Amucor and PET
surface	bright	tinned	bright	textile	bright
foil thickness	0.035 mm	0.1 mm	0.023 mm	0.06 mm	0.35 mm
total thickness	0.060 mm	0.125 mm	0.048 mm	0.0825 mm	0.3725 mm
adhesive	synthetic conductive resin	synthetic conductive resin	synthetic conductive resin	synthetic conductive resin	synthetic conductive resin
adhesive performance	4.5 N/cm	4.5 N/cm	4.5 N/cm	4.5 N/cm	4.5 N/cm
tensile strength	55 N/cm	-	-	-	-
temperature resistance	-	-	-	-	-
el. resistance through adhesive	0.003 Ohm	0.003 Ohm	0.003 Ohm	0.003 Ohm	0.003 Ohm
standard roll widths (mm)	10, 25, 50, 100	10, 25, 50, 100	10, 25, 50, 100	10, 25, 50, 100	10, 25, 50, 100
roll lengths	16.5 m	16.5 m	16.5 m	16.5 m	16.5 m

Other roll lengths on request

For larger areas it is more economical to use foil (see page 36) in combination with these tapes.

**Ordering
information**

Example

Copper tape with conductive adhesive (3201) 25 mm wide and 16.5 meters long.
Order code: **3201-25-16.5**

Part number	Width (mm)	Length (m)
3201	25	16.5

Shielding foils 5800

Die-cut/Jet cut to any shape



For shielding enclosures made of plastics and PCB



Foils for EMI Shielding

Many EMI problems can be solved easily by the use of conductive foils and conductive sheets. Some of the most commonly used materials are Mu-copper foil, reinforced Amucor foil and highly conductive textile.

All of these materials can be produced with or without (conductive) self-adhesive and an optional insulation layer.

Applications

- Shielding plastic enclosure parts
- Shielding all non-conductive materials
- Ground plane
- Antistatic floor
- Electrical connection between surfaces (sheets / foils)
- Die-cuts
- Shielding in housings
- Shielding cables
- Temporary shielding during tests

Options

- Flame retardant version
- With (conductive) self-adhesive backing
- With insulation layer
- Die-cut to any shape

Standard part numbers

Product name	Thickness (mm)	Max. width (mm)	Part number	Part number with insulation layer (UL94V-0)	
				0.15 mm (white)	0.22 mm (black)
Copper	0.035	600	3281	3401	3451
Copper	0.12	1000	3282	3412	3452
Copper	0.18	1000	3283	3418	3458
Copper with paper insulation	0.035	1500	3287	3407	3457
Tinned copper	0.035	400	3285	3402	3462
Alluminium	0.035	1000	3286	3403	3453
Amucor	0.023	1100	4701	4704	4705
Mu-ferro (Low frequency shielding)	0.1	400	3284	3408	3468
Conductive textile	0.06	1070	4711	4714	4715
Amucor with PET in the middle	0.35	-	4716	4719	4720

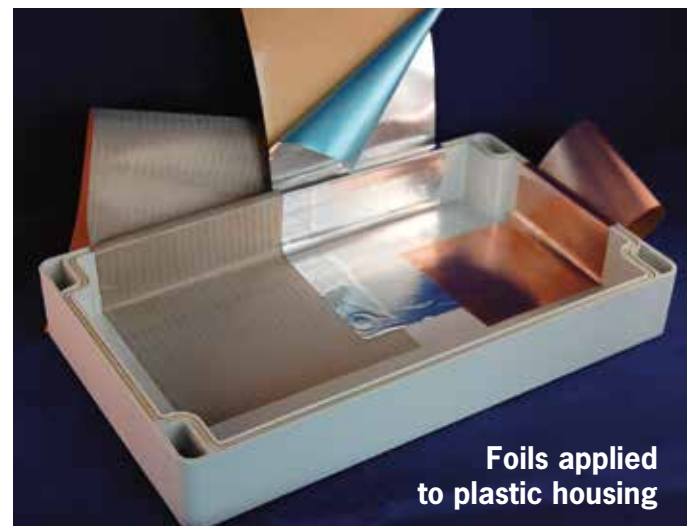

Foils applied to plastic housing

Shielding foils 5800

Die-cut/Jet cut to any shape



We can flash-cut foil to any shape

3281, 3282, 3283 Mu-copper foil

Mu-copper foil has superb shielding performance (also at low frequencies), can be soldered, and can easily be folded into the right shape

Part numbers

- 3281 Mu-copper foil (0.035 mm thick)
- 3282 Mu-copper foil (0.12 mm thick)
- 3283 Mu-copper foil (0.18 mm thick)

Benefits

- High shielding performance
- Easy to solder
- Flame retardant

3284 Mu-ferro foil

Metal foil used for shielding against low magnetic frequencies. For more information see page 57.

3285 Tinned copper foil

Same as 3281 with tin layer added for corrosion protection and improved solderability.

3286 Aluminium foil

Special developed especially for aluminium housings and frames to prevent galvanic corrosion.

3287 Copper foil with paper insulation

Same as 3281 but with a layer of paper added to insulate the top layer of the foil.

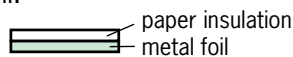

4701 Amucor foil

The reinforced Amucor foil is both cost effective and heat resistant. This thin foil can be applied easily to any surface or housing shape. We can also supply it in a die cut version. Thickness 0.04 mm.



Benefits

- Cost effective
- Follows the contours of your housing easily
- Flame retardant
- Extremely strong
- Corrosion free

4711 Conductive textile foil

Conductive textile with self adhesive can be applied easily to plastic housings to cover non-standard forms and shapes. Laminates of metal foils with flame retardant Nomex or Valox are also available.

Our engineers can help you develop the right design to create overlaps, holes or connectors, cables and spuds. Thickness 0.10 mm

Benefits

- Follows the contours of your housing easily
- Flame retardant
- Extremely strong
- Corrosion free

4716 Amucor with PET in the middle

Amucor foil + PET film + Amucor foil. 2 layers of 11 micron thick Amucor (aluminium type) with 23 microns of polyester inside. This material is extremely strong.

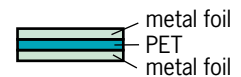

Shielding performance

Field	Frequency	Mu-Copper	Amucor-foil	Conductive textile
-	-	0.12 mm thick	0.04 mm thick	0.10 mm thick
E	1 MHz	125 dB	121 dB	115 dB
E	10 MHz	101 dB	110 dB	108 dB
E	100 MHz	120 dB	103 dB	102 dB
E	400 MHz	115 dB	98 dB	92 dB
P	1 GHz	110 d	92 dB	90 dB
P	10 GHz	120 dB	85 dB	80 dB

See Guarantee

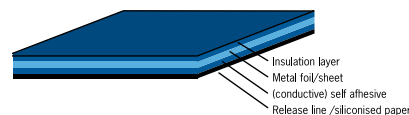

Ordering information

Example

Sheet of Amucor foil, 300 x 200 mm, with conductive self adhesive, without insulation layer.
Part number: **4701-300-200-03-#01**

Part number	Height (mm)	Width (mm)	Option	Top finish
4701	300	200	03	#01
see part number table page 36	01 : standard adhesive (non-conductive) 02 : without self adhesive 03 : with conductive self adhesive			#01 without insulation layer #02 with insulation layer #03 with flame retardant insulation layer #04 with conductive self adhesive layer

Cable shielding 4700/4800

For flat and round cables, can be installed afterward

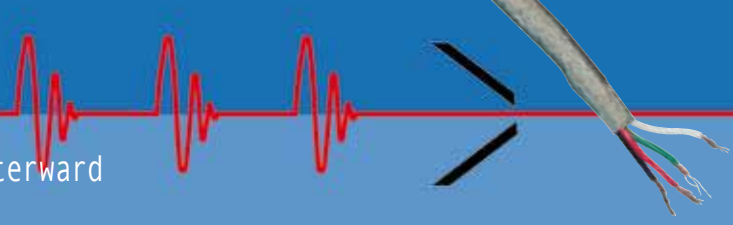

Ready-made sleeve

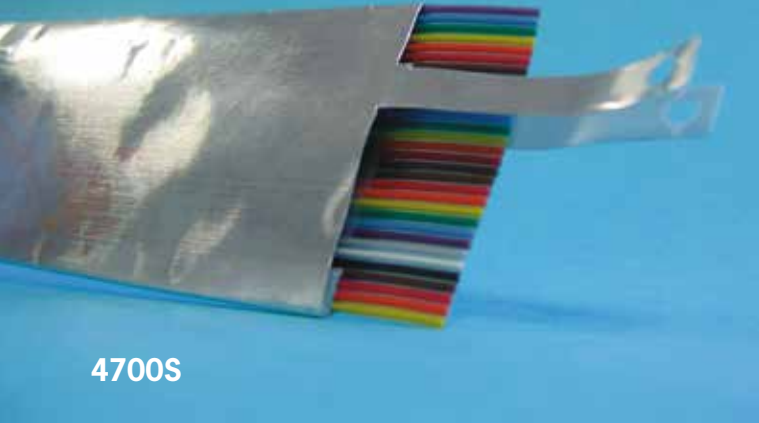

4700S

Cable shielding

The cable shield can be grounded at one end, or both ends of the cable. Cable shielding can be supplied as a ready-made sleeve, on rolls or as a flexible shielding tube. It comes either in continuous lengths, on a reel or cut into lengths.

Ready-made sleeve

Ready-made sleeves can be supplied in **Amucor** or in **Conductive fabric**. The material provides a high shielding performance. The ready-made sleeve is used for cables with large diameters and flat cables. Can be produced with a self-adhesive backing.

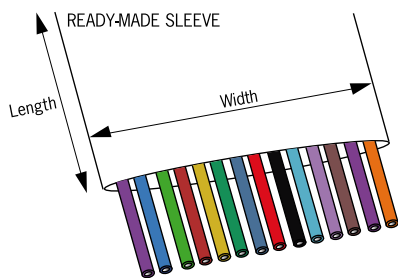

Shielding performance

Frequency Hz	Mode	Attenuation (dB)			
		Amucor	Conductive fabric	Wrapshield	Shielding tube
10 K	H	-	-	4	10
100 K	H	-	-	12	14
1M	H	-	-	18	21
1M	E	121	115	72	121
10M	E	110	108	65	110
100M	E	103	102	62	103
400M	E	98	92	60	98
1G	P	93	90	58	93
10G	P	90	87	42	90

See guarantee

Flexible Cable Shield



4700R

Flexible cable shield

For applications where flexibility is required, e.g. cables with small diameters. The material guarantees superb shielding performance. The product is supplied on rolls and is wrapped around the cable. Flexible cable shield can be delivered in **Amucor** or in **Conductive fabric**, with or without (conductive) self-adhesive.

Options

- With or without self-adhesive
- Supplied on rolls

Benefits

- Can be applied if the cable is a plug
- Highly flexible
- Branches can be wrapped separately

Cable shielding 4700/4800

For flat and round cables, can be installed afterwards



Wrapshield

Cable wrapping is used to shield, ground and statically discharge cables or to harness entire bundles of cables. Wrapshield is a double layer knitted wire mesh supplied on rolls used to wrap around cables. For the best shielding performance make sure there is 50% overlap.

Benefits

- Highly flexible
- High shielding performance
- Wide range of applications
- Shielding performance can be increased by more overlap
- One size for all diameters
- Branches can be wrapped

Flexible shielding tube

This material is a ready-to-use Mu-copper or tinned Mu-copper tube through which a cable or bundle of cables can be pulled. When the tube is compressed lengthwise, the diameter expands to simplify the assembly. Therefore a wide range of cable diameters can be shielded with a single tube.

Please note that the tube has to be expanded for larger diameters and that a larger nominal length will then be required (up to twice the length of the cable).

Benefits

- Highly flexible
- High shielding performance
- Wide range of applications
- Easy to cut
- Useful in a broad range of temperatures and environments.

Pat number

4701

As ready-made sleeve

- 4701S : Flat cable shield - Reinforced Amucor foil
- 4702S : Flat cable shield - Reinforced Amucor foil + self-adhesive
- 4711S : Flat cable shield - Conductive fabric
- 4712S : Flat cable shield - Conductive fabric + self-adhesive
- 4713S : Flat cable shield - Conductive fabric + conductive self-adhesive

On roll (to wrap around a cable)

- 4701R : Flexible cable shield - Reinforced Amucor foil
- 4702R : Flexible cable shield - Reinforced Amucor foil + self-adhesive
- 4711R : Flexible cable shield - Conductive fabric
- 4712R : Flexible cable shield - Conductive fabric + self-adhesive
- 4713R : Flexible cable shield - Conductive fabric + conductive self-adhesive
- 4730 : Wrapshield - Monel
- 4740 : Wrapshield - Tinned copper/steel (TCS)
- 4750 : Wrapshield - Stainless steel
- 4760 : Wrapshield - Aluminium

As flexible shielding tube (tinned Mu-copper)

- 4806 : Flexible shielding tube - for cable Ø 3 - 6 mm
- 4815 : Flexible shielding tube - for cable Ø 5 - 15 mm
- 4824 : Flexible shielding tube - for cable Ø 12 - 24 mm
- 4836 : Flexible shielding tube - for cable Ø 20 - 36 mm

Height (mm)

3

Specify the height of the cable in mm

Width (mm)

36

Specify the width of the cable in mm

Length (mm)

25

Specify the length per sleeve

Width (mm)

50

Standard width: 50 mm, Other on request

Roll length (m)

25

Standard roll lengths: 10, 25, 50 meter

Length (m)

25

Standard roll lengths: 10, 25, 50 meter

Ordering information

PCB shielding 1500/1600/1700

Shielding at the source, also in standard dimensions

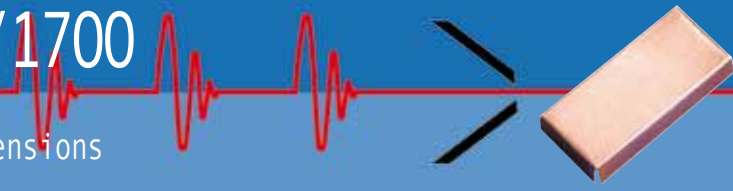

Board level shields

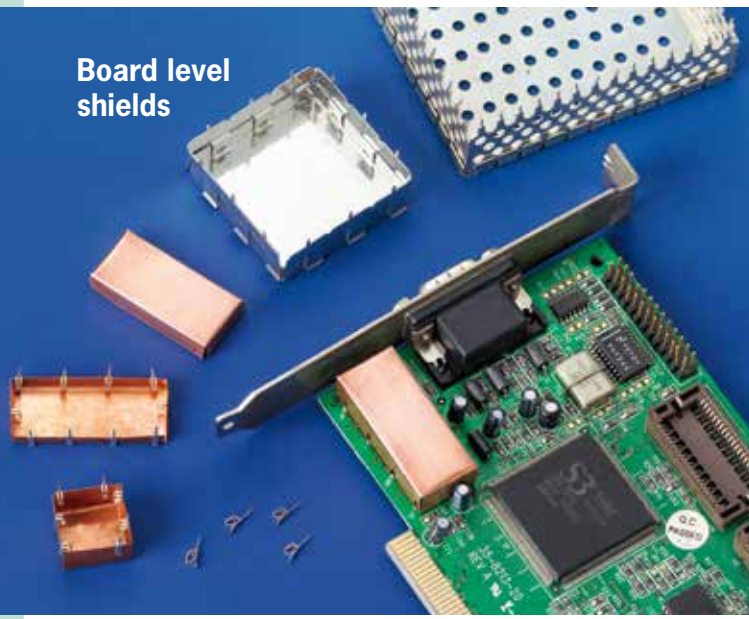

1600 Fixed series

A small framework or fence can be manufactured by our CNC production system, including pins in any desired size. Tooling costs are relatively low, and so this system is well suitable for series of 100 -100,000 pieces. Made according to your drawing.

Options

- Several thicknesses
- With or without electrical insulation
- With or without conductive self-adhesive
- Available in a flame retardant version

1700 Drawn Board Level Shields

This product is designed for seamless corners for ultra-high frequency shielding. Available in heights of 0.5 to 8 mm and sizes of 6 to 80 mm. Elastomers can be combined with the drawn board shield as well as ventilation.

EMI screening covers for printed circuit boards

EMI screening covers for PCBs were developed to shield only a part of electronic equipment from electromagnetic radiation at the source, rather than all components in the entire housing.

1500 Clip-on shielding system

This system combines small clip-on pins with a removable lid and results in high EMI shielding protection.

Benefits

- Less space taken up on the board
- Flexible pin positions making the clip-on system 1500 an excellent solution for series of 1 – 5,000 pieces
- For heavy duty applications the lid can also be fixed by extra soldering between the lid and some of the pins.

Standard cover sizes

Custom sizes can be reproduced on request.

Length (mm)	Width (mm)	Available heights (mm)
20	20	3, 5 or 10
25	25	3, 5 or 10
30	30	3, 5, 10 or 15
40	40	3, 5, 10 or 15
50	25	3, 5, 10 or 15
50	50	3, 5, 10 or 15
75	50	3, 5, 10 or 15
75	50	3, 5, 10, 15, 20 or 25
75	75	3, 5, 10, 15, 20 or 25
100	50	3, 5, 10, 15, 20 or 25
125	75	3, 5, 10, 15, 20 or 25
160	100	3, 5, 10, 15, 20, 25, 30 or 35



Drawn board level shield

1800 Compartment shield

Another application is a highly conductive foil laminated with a high deflection, low closure force foam layer. The rigidity of the housing is used to shield the separations on the PCB. Combinations with conductive fabrics or non-woven are also available.

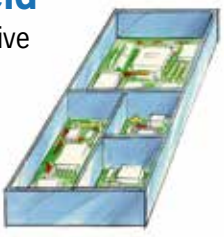

EMI screening covers for PCBs

PCB shielding 1500/1600/1700

Pins and clips for SMD mounting

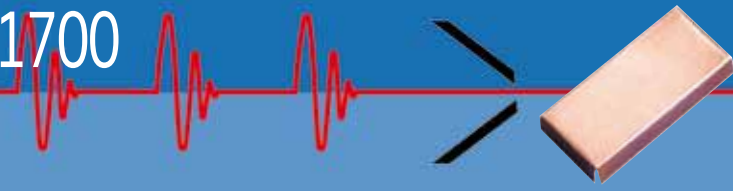

Mounting options

Small pin (P)

Standard through-hole clips with a tinned pin, can be soldered into the PCB at any available place around the screening cover.

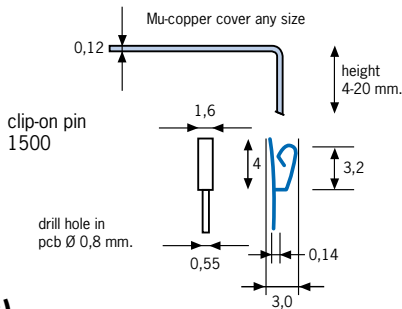

Medium and large clips can be delivered on reels



Medium clip (MC)

This clip is used to mount on to the surface of the PCB (SMT) and offers a fast solution for assembling RFI/EMI shields to PCBs. This clip eliminates the need for through holes and post reflow operations on the PCB. This clip offers a great opportunity to do tuning and re-work after the assembly of the screening cover. Thickness of the screening cover can be 0.13 to 0.23 mm. This clip can be supplied on reels of 5000 pieces.

The medium clip takes up 40% less space than the large version.

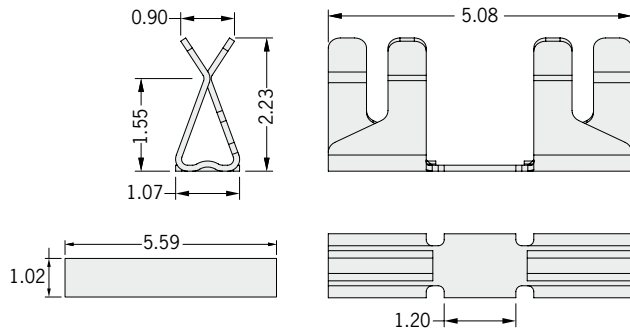

Large clip (LC)

Same as the medium clip, except that thicker screening covers can be used. Screening covers can be placed in the clip up to 0.3 mm thickness. This clip can be supplied on reels of 1900 pieces.

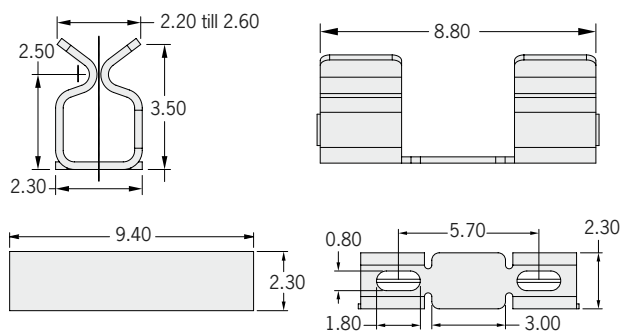

High Volume Production

From 1,000 - 250,000 + items

- In-house tooling facility
- Global materials procurement to ensure quality and competitive price
- Tape and reel packaging of components to allow high speed, high volume automated placement

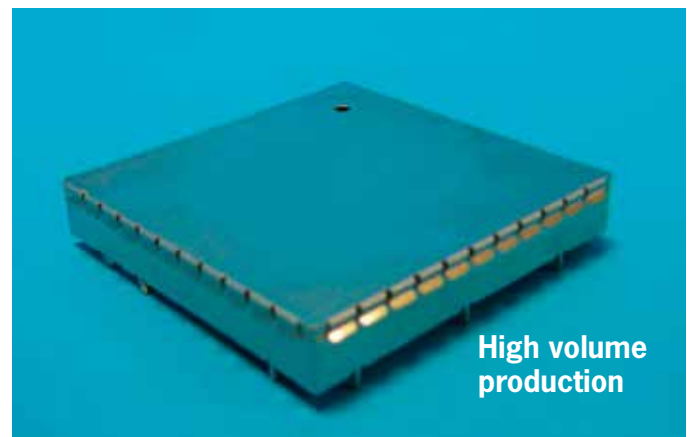

Ordering information

Example

When you order 1500 series screening cover 20 x 20 x 10 mm with medium clips to mount on the surface of the PCB.

Part number	Length (mm)	Width (mm)	Height (mm)	Mounting	Clip/pin
1500	20	20	10	MC	8

1500 : Clip-on shielding system
1600 : Fixed series
1700 : Drawn board level shield
1800 : Compartment shield

Length of the shielding cover in mm

Width of the shielding cover in mm

Height of the shielding cover in mm

If you use the 1500 series, please specify the mounting option
P : Small pin (drilled holes)
MC : Medium clip (SMD)
LC : Large clip (SMD)

Number of clips/pins desired?

Glue, coating and metallization

For plastic enclosures and housings



Conductive metallization 3838

For higher demands and larger quantities we can sputter a full metal coating on 90% of all commonly used plastics, even on PTFE! Applied as a sandwich of three thin layers of metal.

First a thin layer of stainless steel, to prevent the softeners in the plastic affecting the shielding. Secondly a thin layer of copper for superb shielding performance. And thirdly another layer of stainless steel to avoid corrosion.

Conductive nickel coating 3801

For plastics

A fast and easy way to shield plastic enclosures is by applying a conductive paint containing nickel, copper or silver. The paint comes in aerosols for easy use, but can also be supplied in tins of 7 kg (3805) and 28 kg (3820) for larger quantities.

Benefits

- Low surface resistivity of $0.9\Omega/\text{sq}$ yielding a high attenuation
- Aerosol enables speed and ease of coverage of complex shapes
- Delivery from stock



Conductive metallization 3838



Shielding performance

Frequency (Hz)	Attenuation (dB)	
	Coating	Metallization
30M	36	50
100M	38	68
200M	44	70
500M	54	74
700M	54	72
900M	50	70
See guarantee		

Shielding effectiveness depends on surface and material used.

Glue, coating and metallization

For plastic enclosures and housings

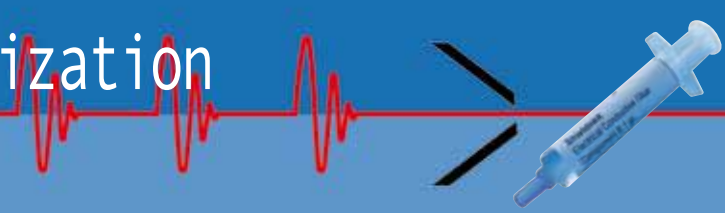

Conductive silver coating 3850

Silver pigmented conductive coating

Silver coating 3850 is the latest in a series of coatings which provide electromagnetic compatibility (EMC). This product has been specifically designed to offer increased coverage while maintaining very high conductivity.

This is a very economic means of achieving excellent shielding against emitted electromagnetic interference (EMI).

This coating retains its low resistance even after exposure to heat, cold, humidity and salt spray. It is an air drying system that requires no primer or top coat.

It is easily applied by spray or brush and is compatible with plastics commonly used for electronic equipment enclosures.

Benefits

- Excellent conductivity
- Very smooth, bright coating
- Meets UL specification 746-C
- Overspray easily removable with MEK
- Excellent adhesion to substrates such as polycarbonate, ABS, polystyrene and PC/ABS blends

Curing

Silver coating dries in 4 to 16 hours of air drying. It may be force dried for 20 minutes at 60-70°C.



Conductive silver coating 3850



Conductive adhesive 3980

Shieldokit 3980 creates an electrically and thermally conductive connection between components. One of the applications is EMI shielding. The glue can cure at room temperature and has excellent filling properties. The thickness is like peanut butter, so uneven surfaces can be filled in. The product consists of a 80% silver-filled two-component epoxy-based glue. It is a paste and adheres to metals (copper, aluminium, stainless steel, brass, etc.), ceramics and most plastics.

Curing

Temperature	Time
21°C	30 hours
50°C	3 hours
80°C	2 hours
100°C	1 hour
200°C	10 min

Specifications

Silver Content	± 80%
Surface Resistance	0.5 Ohm/cm ²
Specific Resistance	0.0025 Ohm/cm
Shelf Life	6 months (cool and dry)
Shear Strength	10-13 N/cm ²
Temperature (continuous)	150°C
Temperature (brief)	200°C

Part numbers of conductive coatings and glue.

Part number

3801

- 3801** : Aerosol 365 ml
- 3805** : Tin 5 liters (7 kg)
- 3820** : Tin 20 liters (28 kg)
- 3838** : Conductive metallization
- 3850** : Silver coating 100 gr
- 3980** : Conductive adhesive 50 gr

Ordering information

Connector gaskets 8200

All kinds of connector gaskets, specials also available

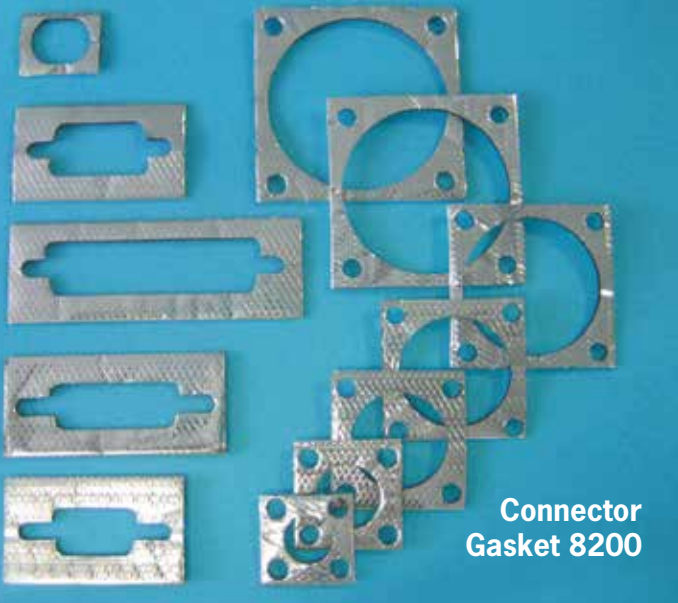

Connector Gasket 8200

EMI flange seals for electrical connectors

The 8200 series connector gaskets are die-cut gaskets for EMI shielding and grounding of a wide range of connectors. These new connector gaskets are more effective in closing gaps caused by fabrication tolerances and misaligned or irregular surfaces than would be possible with a solid flange design.

The 8200 series is made of die-cut Amucor-shield 6800 or conductive textile, 1 or 2 mm thick, provided with self-adhesive.

Sub-D connector gaskets

Shell Size	Dimensions in mm				Front Mounting		Rear Mounting	
	E	F	G	H	L	K	L	K
9	33.35	25.00	19.05	3.56	19.86	11.43	16.89	9.40
15	41.68	33.33	19.05	3.56	28.20	11.43	25.22	9.40
25	55.58	47.04	19.05	3.56	41.91	11.43	38.94	9.40
37	71.86	63.50	19.05	3.56	58.37	11.43	55.40	9.40
50	69.60	61.11	21.85	3.56	55.88	16.82	53.01	12.19

Please order size with (F) Front or (R) Rear Mounting.

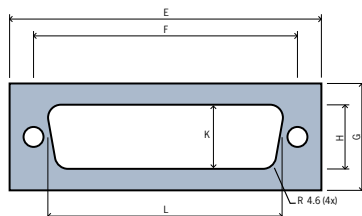

RF Connector Gasket

Connector Type	Dimensions in mm			
	A	B	C	D
BN	17.45	12.70	11.10	2.77
BNC	17.45	12.70	11.10	2.77
C	25.40	18.26	15.88	4.37
HN	30.18	23.01	19.05	3.56
LC	50.80	36.50	31.75	6.53
N	25.40	18.26	15.88	4.37
UHF	32.54	24.61	25.40	4.37

JT, PT, PC, MIL-C-26482, MS-3110, MS-3112, MS-3119, MS-3120 connector gaskets

Part Number/Shell Size	Dimensions in mm			
	A	B	C	D
8206	17.48	11.91	9.53	3.30
8208	20.62	15.09	12.70	3.30
8210	23.83	18.26	15.88	3.30
8212	26.19	20.65	19.05	3.30
8214	28.56	23.01	22.23	3.30
8216	30.86	24.61	25.40	3.30
8218	33.32	27.00	28.56	3.30
8220	36.53	29.36	31.75	3.30
8222	39.70	31.75	34.93	3.30
8224	42.88	34.93	38.10	3.96

AN, HT, QWL, MIL-C-5015, MS3100, MS3102 connector gaskets A Series

Part Number/Shell Size	Dimensions in mm			
	A	B	C	D
8208A	22.23	15.09	12.70	4.37
8210A	25.40	18.28	15.88	4.37
8212A	29.79	20.65	19.05	4.37
8214A	30.16	23.01	22.23	4.37
8216A	32.54	24.61	25.40	4.37
8218A	34.3	27.00	28.56	5.15
8220A	38.10	29.36	31.75	5.15
8222A	41.28	31.75	34.93	5.15
8224A	44.45	34.93	38.10	5.15
8228A	50.80	39.70	44.45	5.15
8232A	57.15	44.45	50.80	5.56
8236A	63.50	49.23	55.58	5.56
8240A	69.85	55.58	61.93	5.56
8244A	76.20	60.33	70.64	5.56
8248A	82.55	66.68	76.99	5.56

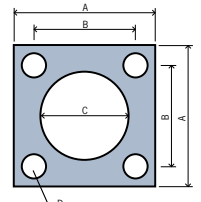

Bendix-SP Connector Gasket B Series

Part Number/Shell Size	Dimensions in mm			
	A	B	C	D
8206B	24.21	16.28	9.53	4.06
8208B	26.59	18.64	12.70	4.06
8210B	28.56	20.62	15.88	4.06
8212B	31.75	23.83	19.05	4.06
8214B	34.93	26.19	22.23	4.06
8216B	36.50	28.56	25.40	4.06
8218B	38.51	30.56	28.56	4.06
8220B	42.47	32.94	31.75	4.06
8222B	44.45	34.93	34.93	4.06

Example

Connector gasket 8208A with an Amucor foil (A) covering, 1 mm thick

Ordering information

Part number	Covering	Thickness (mm)
8208A	A	1
Select the part number from the connector gasket part number tables	T: Conductive textile A: Amucor foil B: Embossed Amucor foil	Standard 1 or 2 mm. Other thicknesses on request.

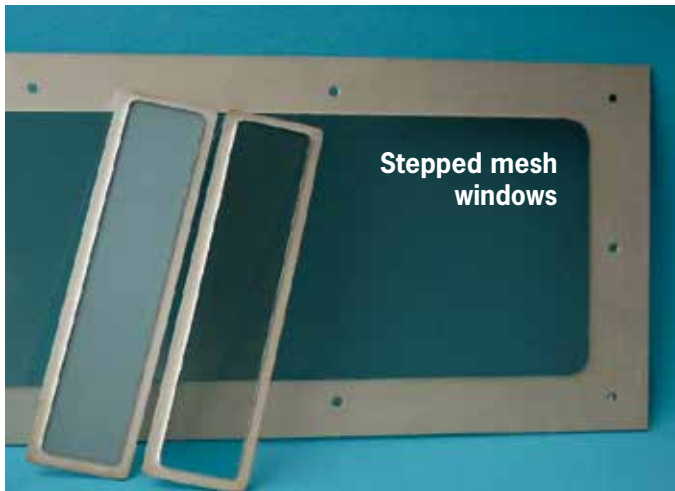
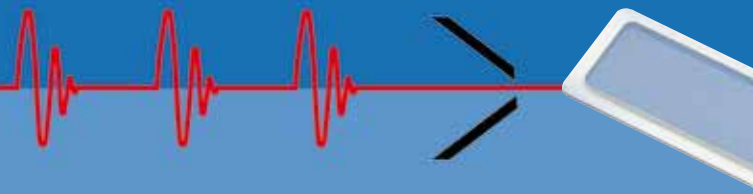

Cast/Mesh windows

For the highest shielding performance a woven microstructure of mesh is bonded between two layers of glass/plastic (stepped window) or a single layer of mesh foil is fixed onto one side of the window with self-adhesive (single window). This can be done by laminating or edge-bonding.

The windows can be provided with a silver bus bar, a gasket or be supplied with a frame for easy mounting. Windows can optionally be provided with water seal.

Light transmission

Opacity of mesh windows is 64,5%. A lack of available light need not be a concern, since an average pair of sunglasses allows less than 9% light to come through.

Applications

- LCD displays
- Membrane switches
- Touch screens etc.
- Defence / Avionics

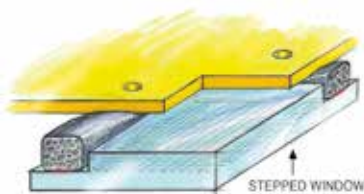

Shielding performance of mesh windows

Material	Stainless steel				Phosphor Bronze		Copper		Conductive Coating	
Type (wires/inch)	70	80	100	250	100	250	70	100	-	
Wire diameter (mm)	0.076	0.050	0.050	0.035	0.097	0.035	0.076	0.050	-	
Nominal aperture (mm)	0.287	0.267	0.204	0.067	0.157	0.067	0.287	0.204	-	
Light Transmission %	62.6	71	64.5	43.5	38.2	43.5	62.6	64.5	65-95%	
Attenuation (dB)										
Field Type	Frequency	dB	dB	dB	dB	dB	dB	dB	dB	
H	10 kHz	20	21	22	22	22	20	24	22	-
H	100 kHz	21	23	23	22	42	24	39	35	-
H	1000 kHz	30	33	29	37	61	40	58	54	-
E	1 MHz	90	104	101	114	120	120	105	111	73
E	10 MHz	89	86	75	91	110	97	100	99	65
E	100 MHz	69	75	68	78	96	91	86	95	64
P	1 GHz	66	60	64	75	79	87	66	72	20
P	10 GHz	33	32	35		46	60	34	45	-

See guarantee

Faraday cage MRI window

We also manufacture ready to install Faraday cage windows. These windows guarantee high shielding performance. Faraday cage windows can be manufactured in every dimension.

Conductive coating window

For small areas a transparent polyester foil with a highly conductive coating is commonly used. The foil is available with self adhesive or can be laminated onto glass, acrylic, polycarbonate or any other flat surface. The light transmission is 65-95%, depending on electrical conductivity (20-5 Ohm/sq). For the best chemical and mechanical durability and transparency the transparent conductive coating is sputtered directly onto glass or polycarbonate. However, a mesh foil window provides higher shielding performance than a coated window.

Shielding performance conductive coating window

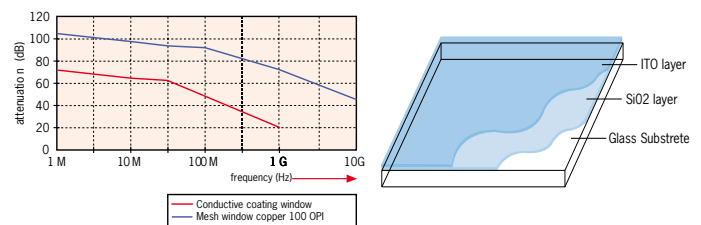

Wall paper system + ceiling

Mu-copper Faraday cages

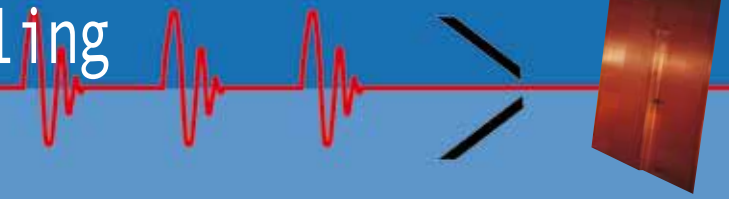

Wall Paper System Mu-Copper

We produce Faraday cages, shielded chambers and other shielding components like:

- Power & signal filters (see pages 58 & 59)
- Waveguides, shielded doors (see page 52)
- Windows (see page 45)
- Shielded ventilation panels (see pages 60 & 61).

In addition we produce, TEMPEST equipment for crypto communication and even welded EMP bunkers. We have a large standard range in stock and we can deliver to the cage building industry in mere days. We also design items according to the client's wishes, with very short delivery times.

Wall covering system (Mu-copper)

Mu-Copper foil has high attenuation properties in the electrical field (up to 120 dB) as well as in the magnetic field (see shielding performance table). It is easy to apply, like wallpaper, thanks to its special adhesive for walls, ceilings and floors. The interior finish can be plaster board, foam tiles or plywood.

The 0.12 mm thick Mu-Copper is used to transform regular rooms into shielded rooms; it has excellent shielding performance even at low frequencies. The system is easy to mount on shielded doors with clamping devices. The standard width of Mu-Copper is 1000 mm and the foil can be delivered on rolls or ready-made sheets.

Overlap options

For the joints you can use a 50 mm overlap. For extra high performance you can fully solder the joint or use a seaming /copper tape with a conductive self-adhesive to apply over the joints.

Advantages

- Cost-effective / takes up little space
- Light weight / high floor load
- Can be constructed with local labor
- Standard interior finish possible like plasterboard
- Can be delivered with 10 year guarantee
- Maintenance free
- Delivery with turnkey measurement report

Shielding performance

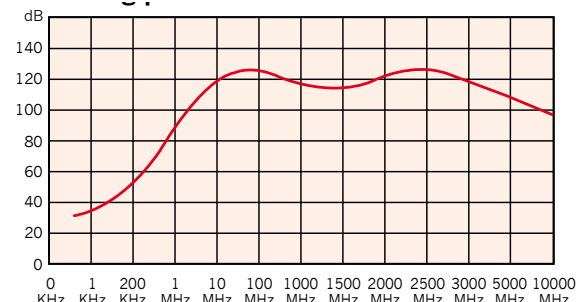

Basic values for the material and Mu-copper cage

Field	Frequency	Mu-Copper
H	1 kHz	22 dB
H	10 kHz	35 dB
H	200 kHz	68 dB
E	10 kHz	99 dB
E	200 kHz	127 dB
E	1 MHz	125 dB
E	18 MHz	101 dB
P	400 MHz	120 dB
P	1 GHz	110 dB
P	10 GHz	120 dB

Shielding performance of mu-Copper foil 0,12mm thick

You can create a Faraday cage with high shielding performance yourself in an economic way, using local labor. This is possible in existing buildings as well as in new ones, without loss of space. Depending on the quality of the doors, vent panels, filters and/or windows used, attenuation levels up to 80-100 dB in the E-field can be realized. When more layers are applied, it is possible to achieve over 120 dB.



Special honeycombs for Mu-copper system

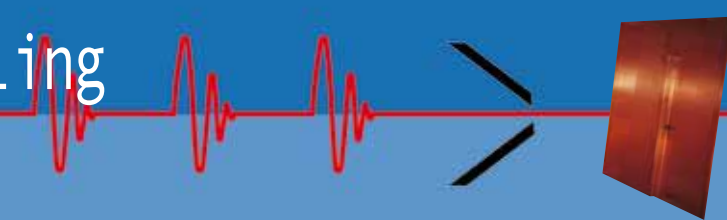

Ceilings

The system can be used with a detachable or fixed ceiling to separate existing ducts and cables from the shielded room.



Detachable ceiling

Ceiling construction

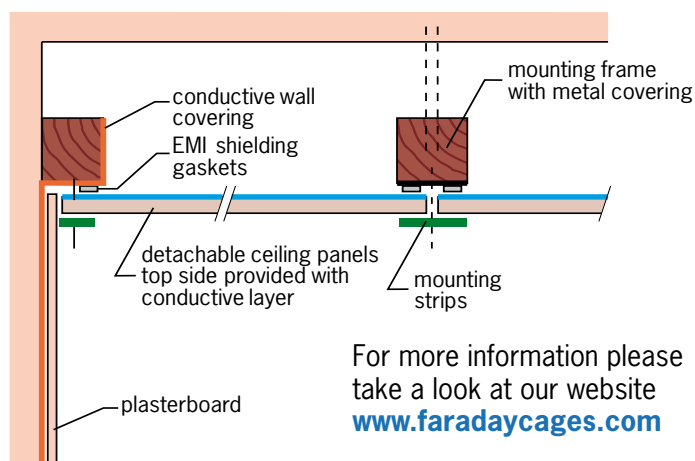

Applications

- Server rooms
- EMC test rooms
- Computer rooms
- Medical examination rooms
- MRI, EEG, EMG & EVP
- Rooms for physiotherapy
- Radar protection/Airport
- TEMPEST Sites
- Military EMC protection
- Board room shielding
- Industrial espionage/Secure room
- Buildings for intelligence agencies

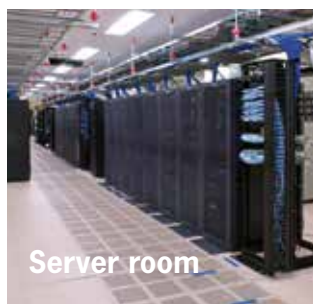

Server room



MRI room

Modified RF Shielded Door

When a lower performance 40-60 dB is acceptable we can retrofit your existing door. The doors will be equipped with gaskets on top and sides, while the bottom is provided with a conductive copper brush and doorstep.

Modification is possible for both swing and sliding doors. (For more informative see page 52)



Standard modified sliding door

Components

In addition to EM shielded doors and windows, the screened rooms can be equipped with the following components:

- Shielded doors (see page 52)
- Shielded windows (see page 45)
- Shielded ventilation panels (see page 60)
- Power and signal filters (see page 58)

When necessary we also offer shielding solutions for water pipes, medical gases and ventilation.

Shielding tents

High performance for high frequencies

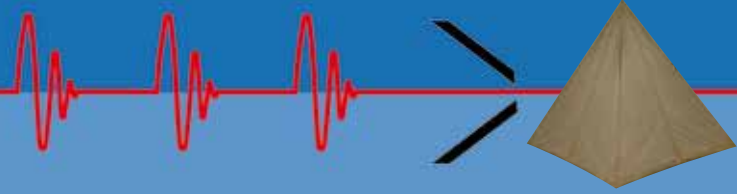

Jumbo dual layer shielded tent

Cost effective instant Faraday tent

The RF shielded Faraday tents are manufactured from strong and highly conductive textile. The tents are standard delivered with multiple ropes for easy mounting to the ceiling or with a self-standing frame. Applications are typically EMC experiments, RF measurements, mobile military / forensic activities and personal protection in the field. Faraday tents offer mobile solutions for only a fraction of the price compared to a conventional Faraday cage.



NEW: Maintain visual contact with your experiment

Typically the access point is made out of magnetic strips covered with electrically conductive layers of textile. The magnetic closure ensures superb electrical contact after the tent is closed. When necessary, the entrance can also be equipped with conductive Velcro strips.

A double layer of fine conductive mesh can be installed allowing you to maintain visual contact between the inside or outside of the tent.

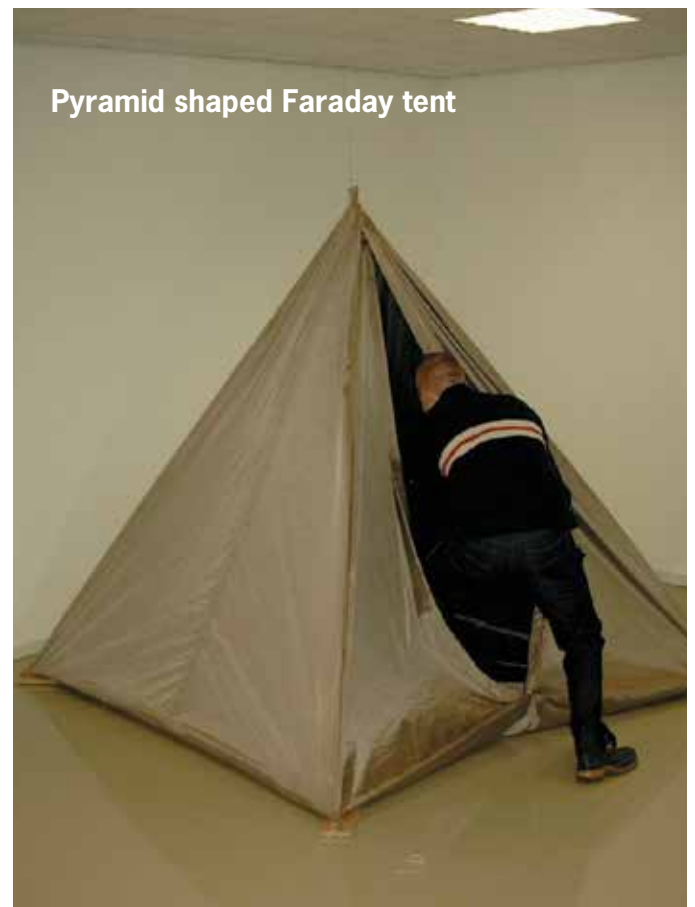

Pyramid shaped Faraday tent

Material

Our RFI/EMI shielding tents are made of highly conductive, lightweight and ultra strong textile.

Shielding performance of tents (dB)

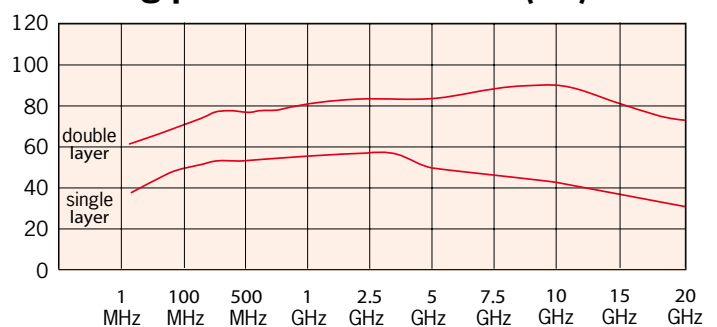

Shielding tents

Easy to mount, store and transport

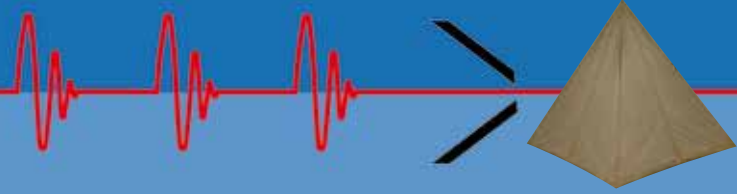

Applications

- Computer and Cell Phone Forensics
- Field Military / Embassy use
- Secure / TEMPEST communication
- Radar jammer protection
- Electromagnetic Allergy / Electro smog
- Pre-compliance Testing
- Temporary EMI Shielding
- Reverberation chamber (RVC)
- Mode-stirred chamber (MSC)

Advantages

- Easy to mount and move, mobile laboratory
- Any size possible
- Optionally supplied with a rigid reinforced floor
- Single layer tent 40-60 dB up to 22.5 GHz
- Double layer tent 70-90 dB up to 22.5 GHz

Options

- Rigid floor for heavy load
- Easy mounting frame
- Shielded power filters
- Shielded ventilation/ AC
- Cable sleeve for entry of filtered cables
- Many other options on request



Optional aluminum mounting frame

Standard sizes available:

All measurements given in the table are outside dimensions

Pyramid

Small	1 x 1 x 2.3 meters	(code P-100x100x230)
Medium	2.5 x 2.5 x 2.3 meters	(code P-250x220x230)
Large	3 x 3 x 2.3 meters	(code P-300x300x230)

Square

Small	2 x 2 x 2.3 meters	(code S-200x200x230)
Medium	2.5 x 2.5 x 2.3 meters	(code S-250x250x230)
Large	3 x 3 x 2.3 meters	(code S-300x300x230)

Rectangular

Small	2 x 2.5 x 2.3 meters	(code R-200x250x230)
Medium	2 x 3 x 2.3 meters	(code R-200x300x230)
Large	2.5 x 3 x 2.3 meters	(code R-250x300x230)
Extra large	3 x 2 x 2.3 meters	(code R-300x200x230)

Round

Small	Ø 2 x 2.3 meters	(code O-200x230)
Medium	Ø 3 x 2.3 meters	(code O-300x230)
Large	Ø 4 x 2.3 meters	(code O-400x230)

Jumbo tent

Size	5 x 3 x 4 meters	(code J-500x300x400-01)
-------------	------------------	-------------------------

Any other size on request.

Most sizes are in stock: please contact us for delivery time.

Ordering information

Example

Rectangular tent, 2 x 3 x 2.3 meters and single layer version.

Part number	Shape	Length (cm)	Width (cm)	Height (cm)	Layers
Shielding tent	R	200	300	230	1
	P : Pyramid S : Square R : Rectangular O : Round J : Jumbo tent	The length of the tent in centimeters	The width of the tent in centimeters	The height of the tent in centimeters	Specify a single layer (1) or a double layer (2) tent

Modular/anechoic cages

High performance in a wide frequency range

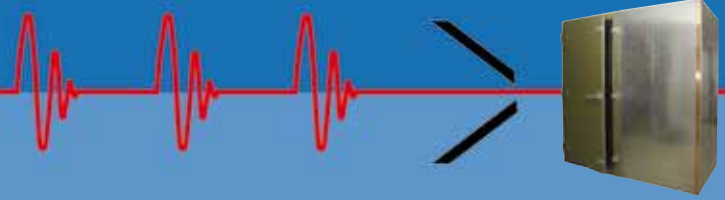

Modular shielding system

Self-standing modular Faraday cage

Superior screening of RF signals, e.g. for R&D, TEMPEST and Testing purposes.

The modular Faraday cage is designed to meet or even exceed the vast majority of shielding requirements. The system is constructed of shielded modular panels, available in either standard-sized or custom-designed panels to meet exacting specifications in government, industry, research and development, university or hospital use. The system is completely self-standing (independent of the host building). The modular panels can be shipped and assembled by the customer or under supervision of our engineers, anywhere in the world.

Applications

- RF measurements
- EMC test labs
- Wireless product testing
- Server rooms
- TEMPEST / Sensitive information protection
- HEMP & EMP protection
- Neuroscience laboratories
- Cellular communication devices
- Immunity & emission test chambers
- Anechoic chambers



EM shielded doors before testing



Self-standing construction

High shielding performance

The shielded enclosure consists of shielding panels made of 2mm MuFerro steel; the panels are galvanized which gives the enclosure excellent resistance to corrosion. Amucor 6800 gaskets between the panels help to maintain shielding attenuation. The modular shielding does not contain any wooden parts that could be adversely affected by variations in temperature or moisture. The panels provide high shielding effectiveness, maintain electrical continuity, and are corrosion resistant. This results in high levels of attenuation without deterioration.

Shielding performance (dB)

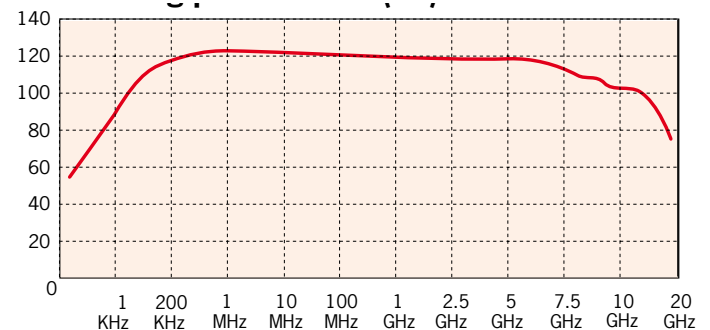

Smooth exterior, functional interior

The panels are bolted together along their edges on the inside, leaving a smooth exterior. Lighting, bus bar and furnishings can be mounted directly on the bendings of the panel interiors. Versions for direct attachment of ferrite and RF pyramidal absorbers can also be supplied, to create an echo-free (anechoic) test chamber.



High performance shielded modular panels (with functional interior)

Modular/anechoic cages

High performance in a wide frequency range

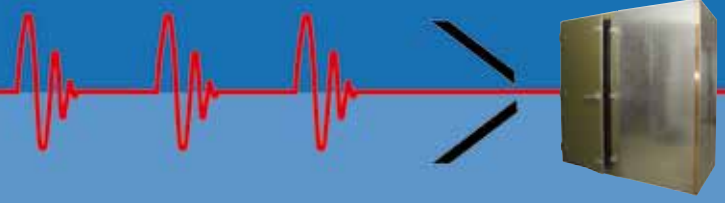

Benefits

- Self-standing construction
- High shielding performance without deterioration
- Easy to mount with local skilled workers
- Easy to modify, enlarge or reinstall
- Many sizes from stock, specials within a few weeks
- Optionally supplied as a kit for assembly by the user
- Optionally with 10 years guarantee & maintenance

Options

All options listed directly below can be customized, e.g. with an automatic sliding door, double leaf door, customized shielded ventilation panels, different dimensions, etc.

- Shielded honeycomb ventilation panels
- Shielded doors
- Shielded water piping and gases
- Lightweight version
- Entry panel fitted with:
 - Power filters, single +N or three phase +N (specify amps, voltage and frequency)
 - Feed through signal filters
 - Wave guides for passage of fiber-optic cables
 - Feed trough penetration (e.g. SMA or BNC connector)
 - Grounding bolt

Standard door dimensions

Dimensions (mm)
Shielded Doors
880 x 2100
1000 x 2100
1600 x 2100
4000 x 6000
Custom sized

For more information concerning our doors see page 52

Easy modification

The modular Faraday cage can be modified, enlarged or reinstalled very easily with conventional hand power tools. Corner panels are identical to the intermediate joints, and have reliable shielding attenuation equal to that of the rest of the enclosure. Examples of panel joints are shown below.

Construction details

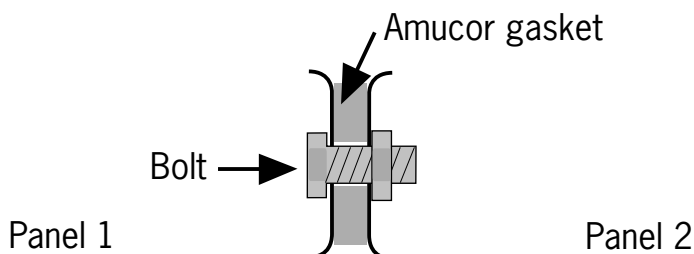

Anechoic chambers

Our anechoic chambers are constructed as shielded rooms. All over the walls and the ceiling, absorbing materials and/or ferrite tiles are attached. The anechoic chambers show superb shielding performance and are mainly applied in EM emission testing according to commercial and military standards. The anechoic chambers are used to perform compliant radiated immunity tests in accordance to EMC-standards such as IEC / EN 61000-4-3. They provide a full compliance immunity test site for the frequency range of 30 to 1000 MHz. Also suitable for future free space emission test, pr EN 50147-3. We also build open area test sites.

Standard cage dimensions

Length (mm)	Width (mm)	Height (mm)
1090	1170	2315 / 2800 / 3405
1090	2260	2315 / 2800 / 3405
2180	2260	2315 / 2800 / 3405
3270	2260	2315 / 2800 / 3405
3270	3350	2315 / 2800 / 3405
4360	2260	2315 / 2800 / 3405
4360	4440	2315 / 2800 / 3405
5450	5530	2315 / 2800 / 3405
Custom sizes		





Double and single swing fingerstrip door

Shielded doors for use in Faraday cages and shielded rooms

We are specialized in designing and manufacturing standard and custom doors, high performance single & double knife edge fingerstrip doors, sliding doors and double swing shielded doors. Our engineers will be happy to assist in finding the best solution possible for your needs.

We also produce sets to shield doors with gaskets at top and sides, while the bottom can be provided with a conductive copper brush and doorstep. See the drawing at the bottom of this page.

Sliding doors

The fully automatic shielded sliding doors are designed for RF and EMP-tight enclosures. These doors can be integrated in shielded rooms as well as with other types of shielding.

The movements of the door and ramp are fully automatic; they are operated electrically and pneumatically. Each opening and closing of the door has a self-cleaning effect on the contact surfaces. Sizes range from 1 x 2.1 meters to a 'jumbo' door of 8 x 12 meters.



Ultra high performance sliding door

Swing doors

The fingerstrip doors are well known for their high shielding performance and are used in prefab cages as well as in our Mu-Copper systems. We manufacture single fingerstrip doors for medium shielding performance and double fingerstrip doors for high shielding performance (reduction up to 140 dB). Delivery from stock in various dimensions. In EMC applications, ferrite tiles can be affixed to the standard door leaf.

Options

- Fire proof
- Automatic closing
- Gas tight
- (Automatic) locking system
- Sound proof
- Clean rooms specifications



Ultra high performance swing door



Locking mechanism

Wooden doors

For applications with a performance up to 40-60 dB we can upgrade your standard doors to a copper plated wooden door, with copper brush and copper doorstep. This is used for hospitals, EEG, EMG and measurements rooms.

Construction details

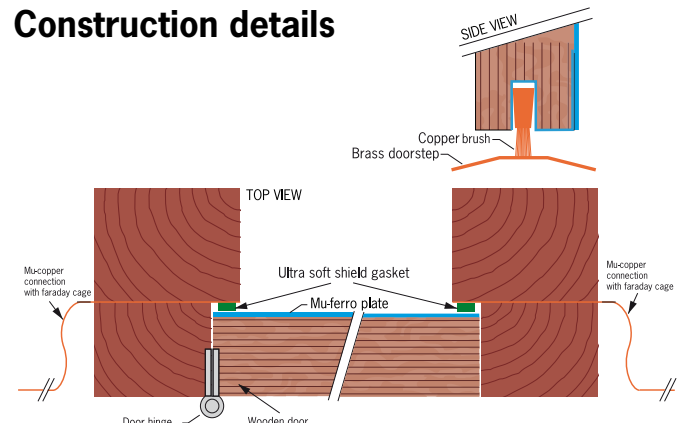

Shielded box/data connections

Portable with high attenuation

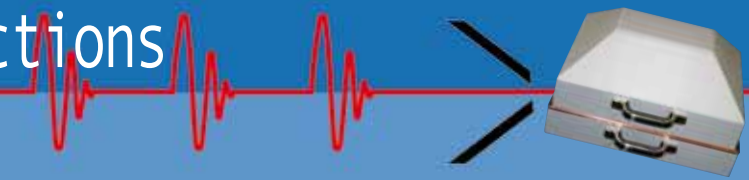

RF shielded boxes for wireless testing & forensics

This RF Shielded box has up to 120dB reduction of RF signals up to 5 GHz. This makes the shielded box ideal for the testing of cellular handsets, RFID, Bluetooth, Zigbee, WiMax, WLAN or similar wireless devices. The box can be constructed in any required size.

The mobility makes the box well suited for forensics when the current state of an electronic device needs to be frozen by blocking all wireless contact with the outside world.

Applications

- Digital forensics
- Wireless testing
- R&D
- EMC Testing

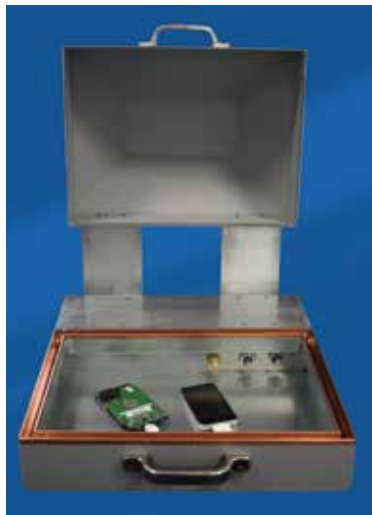

The box can be equipped with shielded power filters for power connection in the box while still blocking all wireless signals. In addition the box can be equipped with any or all of the following options:

Options

- Shielded ventilation panels for heat transportation
- Shielded window to maintain visual contact with the devices
- Coaxial feed-throughs / Signal filters
- Ethernet connection

Shielding performance (dB)

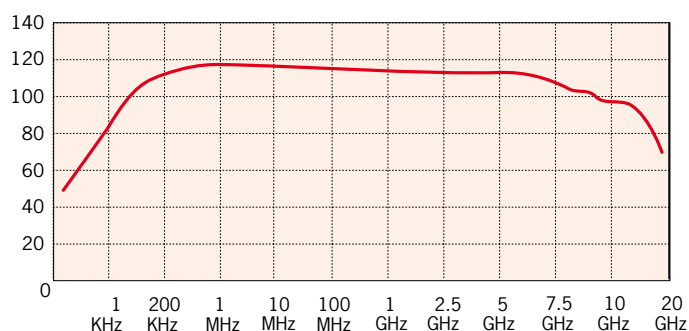

Fiber optic ethernet converter set 7894

Feedthrough set for shielded rooms and Faraday cages.

Shielded room feedthroughs for high speed Ethernet/UTP communication links. The Ethernet fiber Media Converter is used to convert a 10/100Base-T signal to a 10/100Base Optical signal, so you can use your internet connection or for example your video camera connection inside or outside the Faraday cage while maintaining over 140dB of room attenuation.

The set consists of two shielded fiber optic converters, waveguide passage and 5 meters fiber optic cable.

Telephone filters with NEMP protection

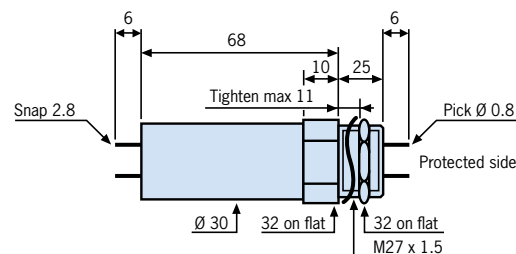
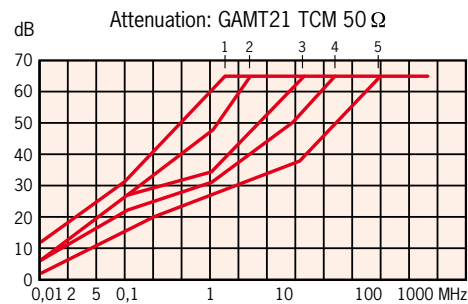

Part Number	Under used	Impedance Ω	Pass band t 3 dB	Resistance Ω	Curve
Tel-5	Telephone CN DT 19200 bauds	600	50 kHz	< 1.5	1
Tel-50	56 kbits/s	600	500 kHz	< 1.2	4
Tel-50-2	64 kbits/s	100/120	500 kHz	< 1.2	1
Tel-100	144 kbits/s	100/120	1 MHz	< 1	2
Tel-200	256 kbits/s	100/120	2 MHz	< 0.5	3
Tel-500	512 kbits/s	100/120	5 MHz	< 0.5	4
Tel-1000	2.048 kbits/s	100/120	10 MHz	< 0.5	5

Absorbers 3500

Sheets and pyramids

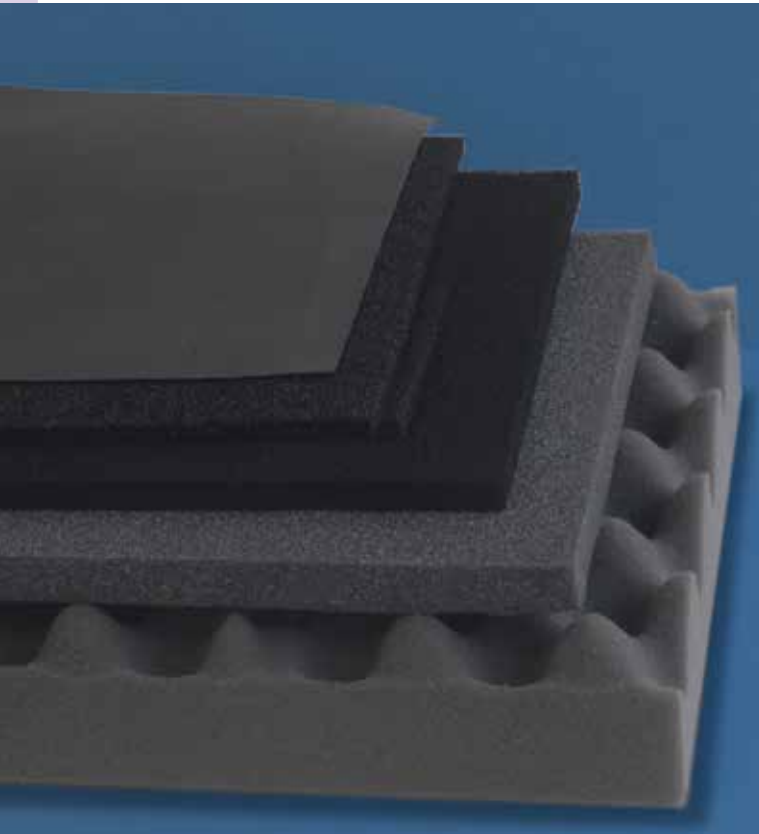

Reflection loss

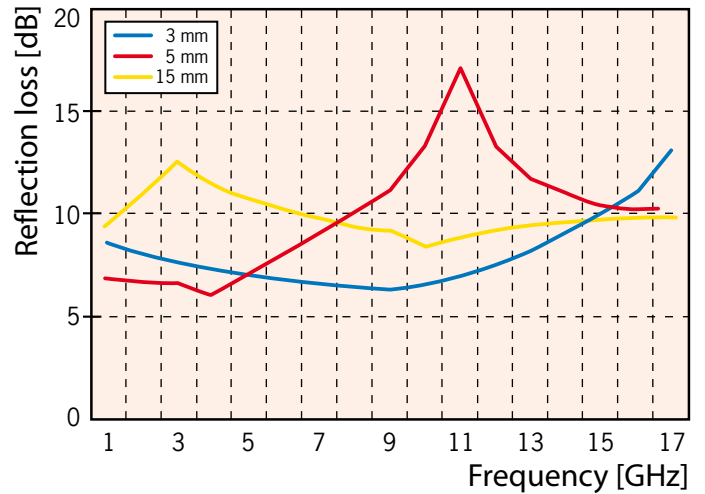

Conductive ferrite absorber

This Ferrite based absorber is both light and flexible and absorbs electronic waves, reduces noise and also absorbs shocks. Depending on the absorber thickness, it covers a range of 30 MHz to 5GHz.

The thicker type is more effective for lower frequencies. The absorber can be delivered with a conductive or a non-conductive adhesive.

EMI absorbing materials are commonly found amongst high-tech products such as LCD electronic devices, laptop and desktop computers. Electromagnetic wave absorbing materials are composed of dielectric materials mixed with ferrite, a magnetic material, with varying shapes and sizes. They are intended to absorb electromagnetic energy at normal and large incident angles over a wide range of frequencies.

Standard size 210x297 mm, thickness 1,0-3,0 mm.

Absorber foam

This RoHS compliant coated open cell foam is used as an absorbing material, especially for application with frequencies 1 - 17 GHz. Typical applications are antenna hats, test boxes and PCB housings. It can be supplied as a die cut (see page 26) or as sheets. Absorber sheets are available in 3, 5 and 15 mm thickness and with or without PSA. Standard sheet size: 200x300 mm.

Temperature spec: - 40 to +100 degrees Celsius, hardness shore: 40 +/- 20.

Absorption rate

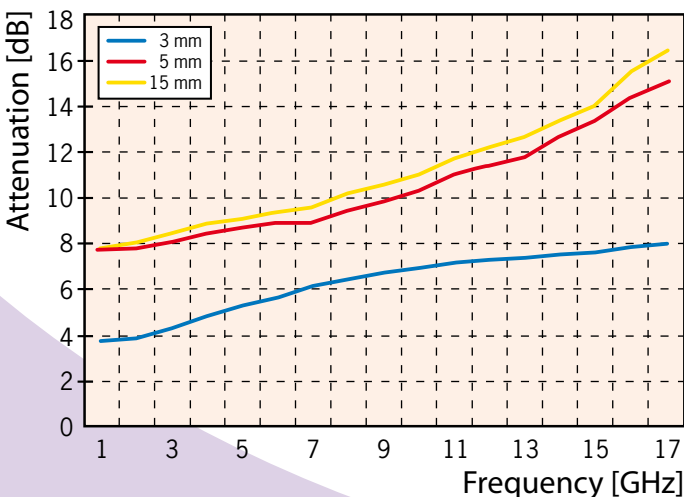

Specification

Property	Test Value
Thickness	0.1 to 3.0 mm
Standard Size	A4 (210 x 297 mm)
Temperature Range	-25 to +100
Specific Gravity	2.9 to 4.7
Elongation	>60 to > 400
Frequency Range	30Mhz ~ 5Ghz
Reflectivity	-4dB ~ 10dB
Thermal Conductivity	-40°C ~ + 130°C
AC Permeability	μ / 15
Insulation Resistance	2.5 x 106 V
Electric Strength	7.9 kv
Tensile Strength	>40 to >100 kg/cm2
Values depend on thickness	

Absorbers 3500

Sheets and pyramids



Hybrid absorber

These absorbers are the most popular solution for 3m, 5m and 10m EMC chambers in the market. They are composed of pyramidal, full tip SAM or truncated SMT pulsing the matching layer to separate the pyramidal part from the ferrite part. Through optimization, this product has a superb performance across 30MHz to 18GHz. The ferrite performs from 30MHz to 1GHz and the foam performs above 1GHz.

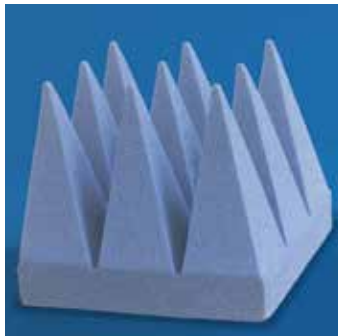

Ferrite tiles

The 100mm tiles can be installed individually using screws or adhesive and are optionally available in panel format. Tiles are surface ground on all sides to precise mechanical tolerances, minimizing gaps between adjacent tiles to ensure maximum low-frequency performance.

Tile Absorber

Ferrite Tile is the industry standard size and exhibits excellent overall performance versus cost.

Features

- Absorption of low electromagnetic waves
- Wide frequency and fire resistant.

Applications

- EMC Electromagnetic wave anechoic chamber.
- Electromagnetic wave reflection of buildings.

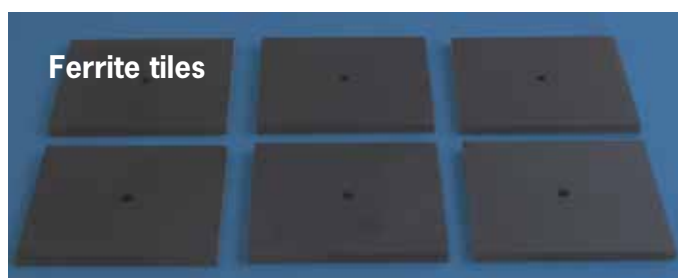
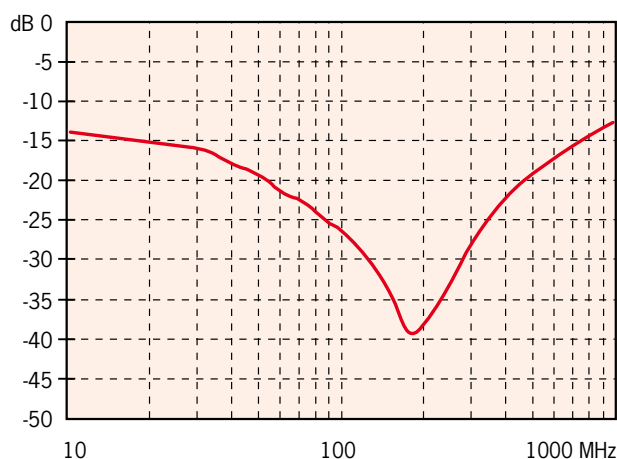

Thermal interface material in solid and liquid form



Thermal interface material

Thermal interface material is used to fill the gaps between thermal transfer surfaces, such as between microprocessors and heat sinks, in order to increase thermal transfer efficiency. These gaps are normally filled with air which is a very poor conductor. The material is easy to handle and is not messy. It is available in solid and liquid form and in various thicknesses.

Thermal conductivity

The thermal conductivity of the interface material has a significant impact on its thermal performance. The high thermal conductivity guarantees sufficient heat transfer, resulting in a better cooling solution and the desired heat dissipation.

Properties

- Good insulation properties
- Heat-conducting
- Good compressibility
- Flexible
- Environmentally friendly

Benefits

- Smooth surface
- Very good thermal transfer properties even at very low contact pressure
- Low hardness
- High self-adhesion
- UL listed
- Thickness 0.01 to 8 mm

This film is especially suitable for high-power applications. It has excellent thermal and electrical properties. Thanks to its good performance, the material can be used reliably in densely packed electronic applications.

Standard part numbers

Part number	Thermal conductivity	Thermal resistance	Hardness	Characteristics
	W/mK	K/W		
Tim-600	6.0	0.20	60-70	highest thermal conductivity
Tim-500	5.0	0.25	75	high thermal conductivity
Tim-300	3.0	0.41	65	flexible, high thermal conductivity
Tim-320	2.5	0.50	30-35	very soft, good dielectric properties
Tim-255	2.0	0.85	30	soft, high thermal conductivity
Tim-202	1.4	0.90	25	good price-performance-ratio
Tim-212lb	1.4	0.90	30	low bleeding behaviour
Tim-105	1.3	0.95	60	good compressibility
Tim-200	1.0	1.5	10	soft, highly compressible
Tim-210lb	1.0	1.5	15	low bleeding behaviour

Magnetic Shielding

Low frequency magnetic shielding



Magnetic field strength measurement

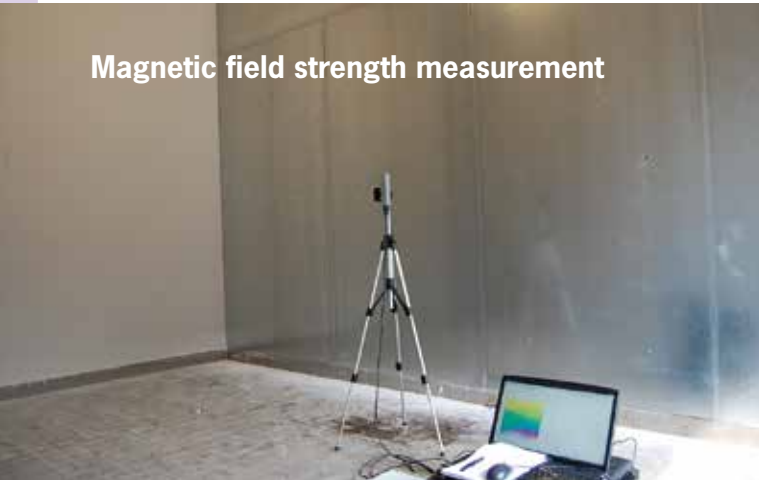

MuFerro 6800

Low-frequency magnetic shielding

A new material for shielding / screening low-frequency magnetic fields has been developed. These fields are generated by installations in which high currents flow, for example transformer rooms, power lines, busbar systems and nearby high-voltage cables.

Indoor transformer rooms



The frequency of these magnetic fields is typically 50/60 Hz. But the MuFerro material is suitable for magnetic shielding in frequency ranges from 0 Hz to 100 KHz.

Customer Benefits

- Cost-effective solution
- Up to 95% field-strength reduction and more
- Flexible design
- Measurement report
- Can be delivered with 10-year guarantee

MuFerro combines permeable and satiety characteristics which make it extremely suitable for screening low-frequency magnetic fields.

Why use magnetic shielding/screening?

Strong magnetic fields can interfere with or damage electronics in the direct surroundings of the field. In addition, magnetic fields negatively affect sensitive measurements in hospitals and laboratories. Apart from their impact on electronics, magnetic fields may pose a serious threat to human health and well-being. For this reason many countries have adopted the recommendation that for working spaces exposure should be $< 0.4 \mu\text{T} = 400 \text{ nT}$.



Applications

- Transformer rooms (indoors or outdoors)
- Power plants
- Hospitals / laboratories
- Aluminium melting/production
- High-voltage labs
- Anything that creates high magnetic fields (high currents)
- Bus bars

Magnetic shielding can be realized even after the transformer has been placed. For screening whole buildings, or rooms, the shielding material is applied to walls, ceilings and/or floors. This protects both people and electronics.

For magnetic shielding of electronic devices Mu-ferro 6800-HD is available in 1 and 0.5 mm thick plate material.

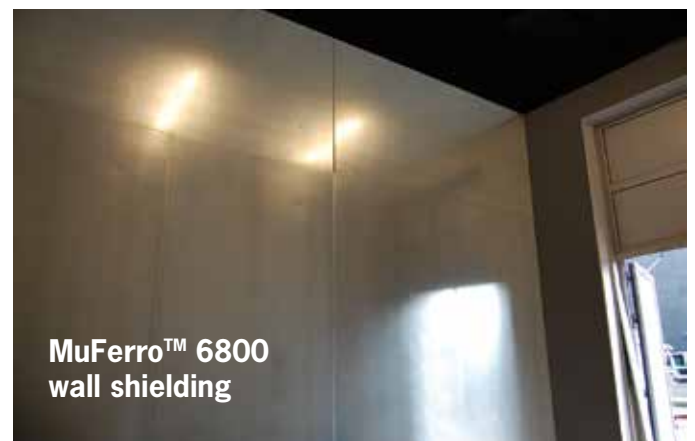

Magnetic Shielding

Low frequency magnetic shielding



Magnetic shielding for sensors and electronic devices

For magnetic shielding of electronic devices and PCBs, Mu-ferro 6800-HD has been developed. Mu-ferro 6800-HD is used to prevent a device emitting low frequency magnetic radiation (0Hz – 300KHz), or it is applied around a sensitive device or sensor, to prevent the electromagnetic interference disrupting normal operations.

Mu-ferro 6800-HD offers important magnetic field shielding characteristics, due to its high magnetic permeability and its ability to absorb magnetic energy. This allows for the highest possible attenuation, making this shielding alloy the material of choice for reducing low-frequency electromagnetic interference.

For magnetic shielding of electronic devices, Mu-ferro 6800-HD is available in 1 and 0.5 mm thick plate material. In addition we can produce custom shapes which will yield the best possible shielding effect for your needs.

Mu-ferro 6800-HD is also available as a foil, delivered on rolls (0.024 mm thick) with or without regular or conductive self adhesive for high frequency shielding and easy mounting.



Shielding performance 2 mm Mu-ferro-HD

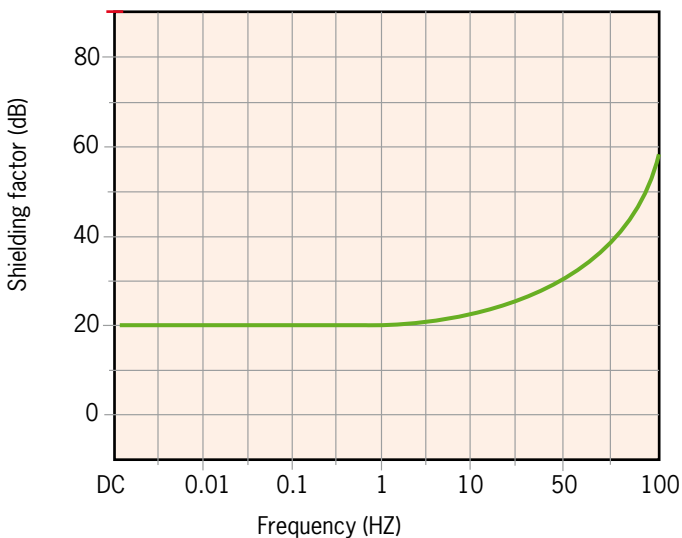

Mu-ferro HD

Properties

Carbon	0.02%
Manganese	0.50%
Silicone	0.35%
Nickel	80.00%
Molybdenum	4.20%
Iron	Balance
Density kg/m ³	8747
Thermal conductivity W/m·K	34.6
Electrical conductivity micro-ohms	580

Applications

- Aviation and aerospace industry
- Sensitive sensors
- Medical equipment
- Physics research
- Telecommunication
- Automotive
- Military

Ordering information

Example

Sheet of Mu-Ferro-HD, 50 x 1000 mm and 1 mm thick.

innovative
EMI shielding
solutions

Part number	Width (mm)	Length (mm)	Thickness
Mu-Ferro-HD	50	1000	1 mm
	Specify the width in mm	Specify the length in mm	Thickness in mm 0,5 mm 1,0 mm

Power filters

Tubular and box filters

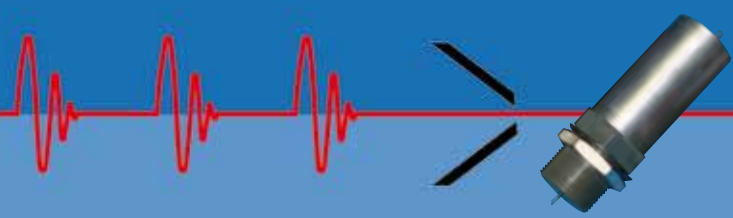

Shielded power line filters

We offer a selection of RFI signal, power, data transmission filters and EMI filters. Apart from the standard products we have in stock, we also design custom EMI/RFI filters for your specific application. For all (H)EMP and most TEMPEST requirements, our high performance filter is suitable. For the entire range and "Ultra high performance" filters up to 120 dB, please refer to our website.

Attenuation characteristics

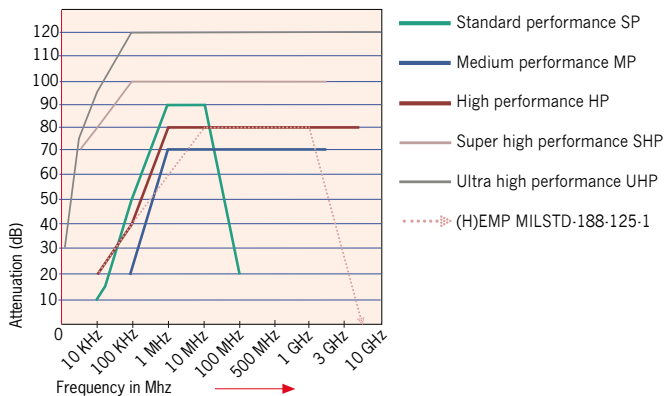

Standard performance power filters

General specifications

- High performance single phase filter
- Suitable to meet latest EMC standards (EN55011, -14, UL 1283 and EN133200)
- Applicable in single phase-powered FC-drives with ling motor-cables
- Very high insertion loss
- Double stage design
- Shock protected screw type terminals
- Ideal for EMC troubleshooting and EMC refurbishing in the field



Mounting

The filter can be directly mounted on the non-painted side of the construction. The SP power line filters feature side flanges for easy mounting and DIN type terminals which eliminate live metal parts, enabling safer and easier connection.

Typical applications

- Frequency inverters
- Variable speed motor drives
- Medical equipment
- EMC trouble shooting

Standard performance power filter

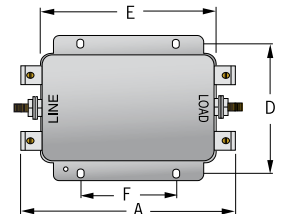
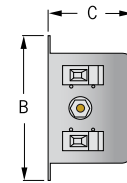
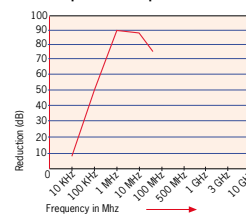

Partnumbers and dimensions

Reference	Rated Current	Connection	Inductance	Max. leakage current at 250V/50 Hz	Dimensions in mm					
					(A)	Type	(L)	(mA)	A	B
SP-2-006	6	Terminal block 4mm	8,8 mH	5.2	116,8	78,7	45,21	67,8	94,0	50,8
SP-2-012	12	Terminal block 4mm	5,6 mH	5.2	151,3	100,6	55,4	88,9	114,8	50,8
SP-2-016	16	Terminal block 4mm	5,5 mH	5.2	151,3	100,6	55,4	88,9	114,8	50,8
SP-2-025	25	Terminal block 6mm	5,0 mH	5.2	175,5	139,2	64,77	124,5	150,9	70,0
SP-2-036	36	Terminal block 6mm	2,0 mH	5.2	175,5	139,2	64,77	124,5	150,9	70,0
SP-2-050	50	Terminal block 6mm	2,0 mH	6.5	175,5	139,2	64,77	124,5	150,9	70,0

Medium performance power filters

Medium performance filters are delivered as tubes or ready for installation on an installation plate. You need as many power filters as you need lines (3 phase + N, means you need 4 tube filters).



General specifications

- PI structure
- Tinned metal case
- Feed through mounting
- Flame retardant V0
- Insulation resistance under 500 Vdc > 100 M Ohm
- Operation temperature: 50 – 60 Hz : - 40°C to +85°C
400 Hz : - 40°C to +65°C

Power filters

Tubular and box filters

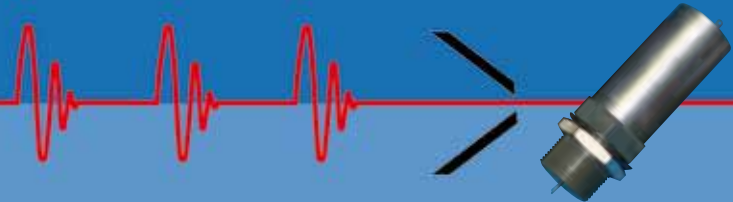

Mounting

Attachment by nut and washer : M16
Torque value max : 20 Nm

Medium performance power filter

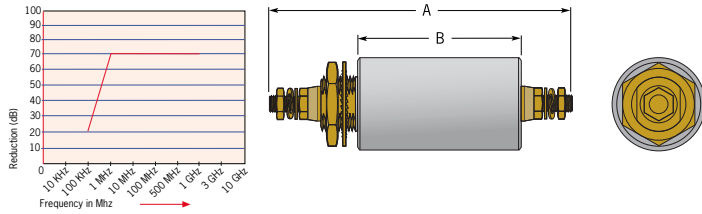

Part numbers and dimensions

Reference (Single phase +N)	Reference (Single phase +N)	Connection	Ohmic resistance	Max. leakage current at 250V/50 Hz	Weight per filter	Dimensions in mm	
						(A)	(B)
MP-2-003	MP-4-003	3	85	17.3	140	105	60
MP-2-005	MP-4-005	5	22	38	175	105	60
MP-2-010	MP-4-010	10	11	81.2	300	131	86
MP-2-025	MP-4-025	25	5	81.2	420	146	101
MP-2-032	MP-4-032	32	3	81.2	420	146	101
MP-2-050	MP-4-050	50	<1.5	<173	860	192	115
MP-2-100	MP-4-100	100	<0.7	<173	880	199	122
MP-2-200	MP-4-200	200	<0.4	<173	940	217	140



High performance power filters

These power line filters are designed for mounting on the penetration panel or directly on the non-painted wall of a Faraday cage or shielded enclosure. Fixed with six additional screws, a feed-through nozzle (supplied with filter) is used to ensure high frequency performance. The non-rotation system ensures correct and easy mounting.

Applications

- Feed-through shielded box filter
- TEMPEST
- HEMP/NEMP
- EMP
- 250V AC – 50/60 Hz
- 10 to 800 A

Technical specifications

Attenuation (50 Ω on load) MIL STD 220 B or GAM T21

High performance power filter

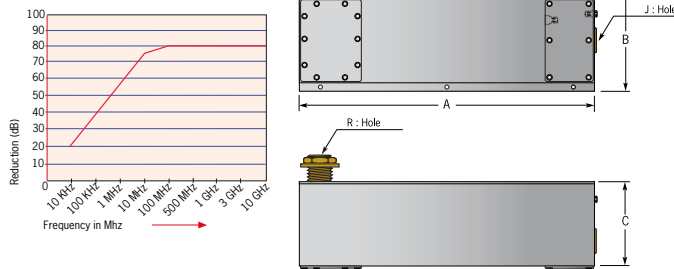

Operating temperature : - 40°C to + 40°C
Test voltage : 1150 VDC (Without varistors)
Overvoltage protection : Varistors
In 10 (strokes) : 25 kA (8/20 μs)
Imax (1 stroke) : 70 kA (8/20 μs)

Single phase + N

Reference Single phase (+N)	Max. Current	Rated Voltage UR (V rms)*	Max. ohmic resistance per line	Max. leakage current at 250V/50 Hz	Max. residual under 5 kA wave 20/500 ns	Dimensions in mm				
						(A)	(B)	C max.	J	R
HP-2-010	10	250	35	0.95	2	425	210	110	Ø33	Ø26
HP-2-016	16	250	22	0.95	2	425	210	110	Ø33	Ø26
HP-2-032	32	250	10	0.95	3	425	210	110	Ø33	Ø26
HP-2-064	64	250	4	1.05	4	425	210	110	Ø33	Ø26
HP-2-100	100	250	2	1.05	4	610	240	110	Ø52	Ø50
HP-2-125	125	250	1.5	1.05	4	610	240	110	Ø52	Ø50
HP-2-200	200	250	1	2	5	610	240	110	Ø52	Ø50
HP-2-250	250	250	0.8	2	5	610	240	110	Ø52	Ø50
HP-2-300	300	250	0.6	3.3	6	610	240	200	Ø52	Ø50
HP-2-400	400	250	0.5	4	6	610	360	200	Ø52	Ø50

Three phase + N

Reference Three phase (+N)	Max. Current	Rated voltage UR (V rms)*	Max. ohmic resistance per line	Max. leakage current at 250V/50 Hz	Max. residual under 5 kA wave 20/500 ns	Dimensions in mm				
						(A)	(B)	C max.	J	R
HP-4-010	10	250	35	0.95	2	560	290	110	Ø33	Ø26
HP-4-016	16	250	22	0.95	2	560	290	110	Ø33	Ø26
HP-4-032	32	250	10	0.95	3	560	290	110	Ø33	Ø26
HP-4-064	64	250	4	1.05	4	560	290	110	Ø33	Ø26
HP-4-100	100	250	2	1.05	4	610	360	110	Ø52	Ø50
HP-4-125	125	250	1.5	1.05	4	610	360	110	Ø52	Ø50
HP-4-200	200	250	1	2	5	700	360	110	Ø52	Ø50
HP-4-250	250	250	0.8	2	5	700	360	110	Ø52	Ø50
HP-4-300	300	250	0.6	3.3	6	700	360	200	Ø52	Ø50
HP-4-400	400	250	0.5	4	6	700	640	200	4xØ40	Ø50
HP-4-800	800	250	0.2	5.5	6	875	690	265	4xØ60	-

Example

Example order of a shielded power filter.

Typical frequency of all our filters is 50 / 60 Hz; other frequencies on request.

Ordering information

Type	Phases	Amps
SP	2	050
SP : Standard performance MP : Medium performance HP : High performance SHP: Super high performance UHP: Ultra high performance	2 : Single + N 4 : Three + N	The amount in amps (A)

Ventilation panels 9500

Shielded vent panels/honeycombs for ventilation

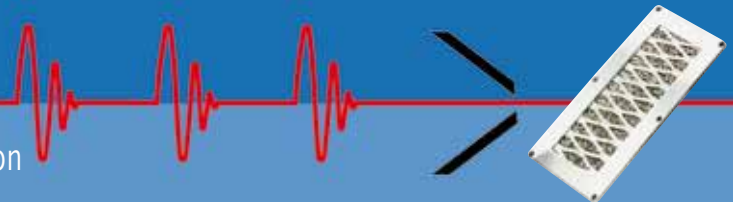

Shielded Vent panels for ventilation and heating



Honeycomb vents are used to shield openings for heating and ventilation against undesirable electromagnetic waves.

The aluminium honeycomb vent panels are supplied in rigid aluminium frames, pre-drilled or with fasteners made to your specifications or flow drilled thread holes.

If a very high shielding level is required, the use of cross-cell honeycombs is recommended. These are made from two pieces of 6.35 mm or 12.7 mm thick honeycomb within a single frame. The shielding performance will improve at the expense of slightly increased air flow resistance.

Benefits

- Light weight
- High shielding performance
- Very low air-flow resistance
- Reduction of turbulence

Options

- Cross-cell honeycomb for extra high shielding performance
- **Slant honeycomb 30°, 45°, 60° for outdoor rainproof applications (high volume only)**
- Polyurethane filter for dust protection
- Mechanical protection against damage
- Stainless steel version
- Brass

Shielding performance

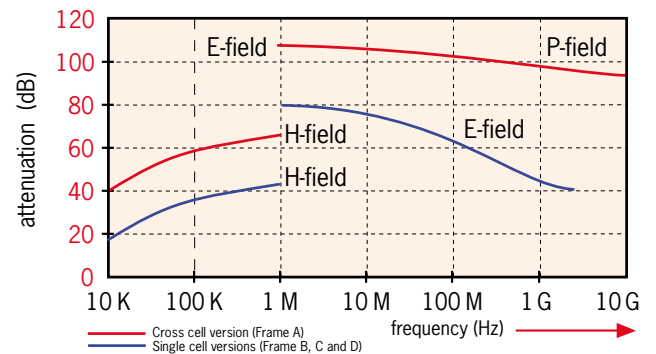

Airflow characteristics

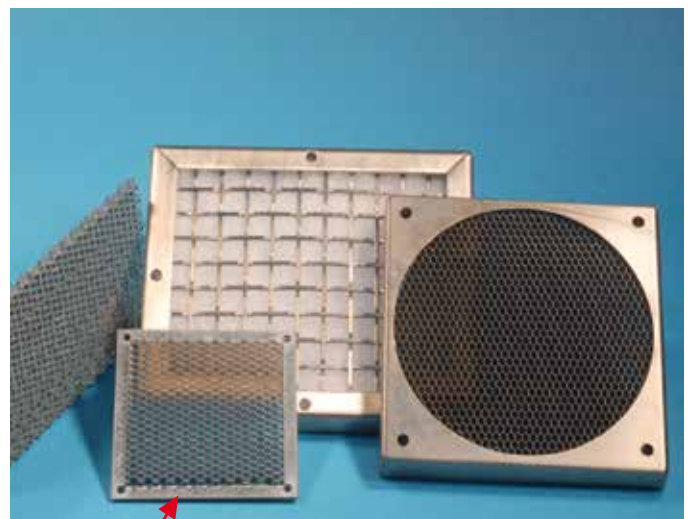
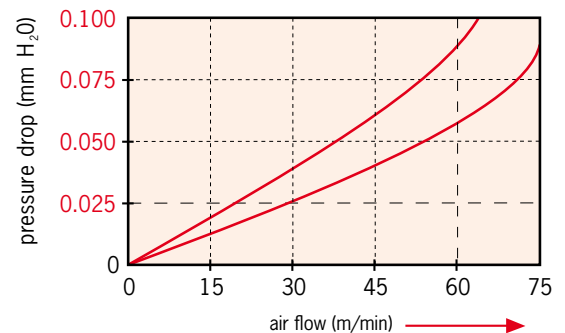

Honeycomb fan shield

Standard delivery time: less than one week!

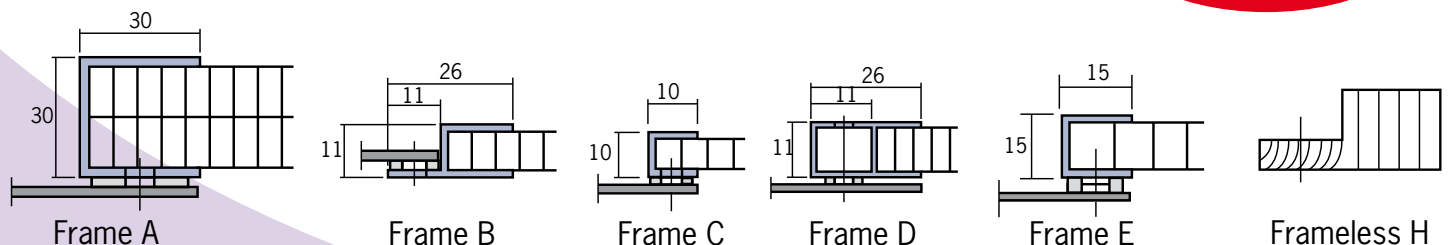

Ventilation panels 9500

Shielded vent panels/honeycombs for ventilation

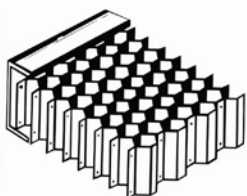
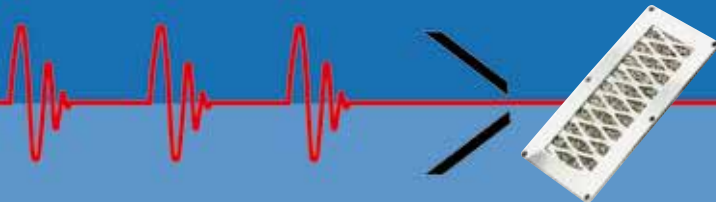

Normal honeycomb

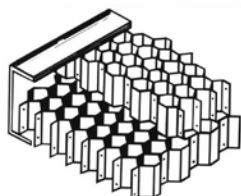

Crossed-cell honeycomb

Shielding performance

Frequency MHz	Mode	Attenuation dB
0.01	H	45
0.1	H	49
1.0	H	51
1.0	E	>100
10.0	E	>100
100.0	E	>100
1000.0	P	98
10000.0	P	95

See Guarantee

Standard dimensions

Outer dimensions		Mounting holes horizontal			Mounting holes vertical		
A	B	no	D	E	no	F	G
Honeycomb fan shield							
40	40	2	-	32	2	-	32
60	60	2	-	50	2	-	50
80	80	2	-	71	2	-	71
92	92	2	-	83	2	-	83
120	120	2	-	105	2	-	105
127	127	2	-	113	2	-	113

Outer dimensions		Mounting holes horizontal			Mounting holes vertical		
A	B	no	D	E	no	F	G
Honeycomb frame shield							
150	75	2	40	70	1	37.5	-
100	100	1	50	-	1	50	-
200	100	3	20	80	1	50	-
125	125	2	20	85	1	62.5	-
250	125	3	30	95	1	62.5	-
150	150	2	25	100	2	25	100
300	150	4	30	80	2	25	100
175	175	2	40	95	2	40	95
350	175	4	40	90	2	40	95
200	200	3	20	80	3	20	80
400	200	5	30	85	3	20	80
250	250	3	30	95	3	30	95
300	300	4	30	80	4	30	80
600	300	7	30	90	4	30	80



Mildsteel Vents for EMP

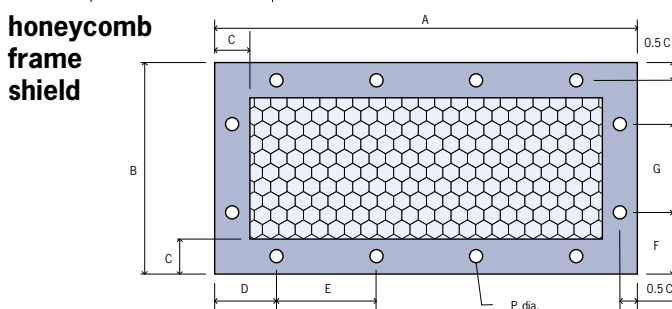
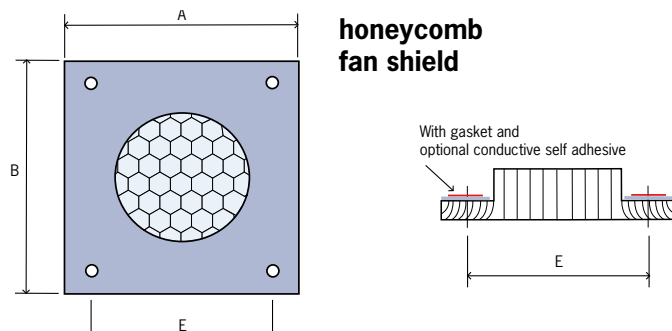

Most of the honeycomb ventilation panels are made according to customer's specifications. For standard part number see table above. When ordering honeycomb vents, the following information should be provided:

Ordering information

The standard material for gaskets is an Endless gasket 8100 series, thickness 2-4 mm, depending on outer dimensions. Any other on request.

Series	Height (mm)	Width (mm)	Frame type	Drill pattern
9500	200	200	C	DS

DS : standard drill pattern
DC : custom drill pattern

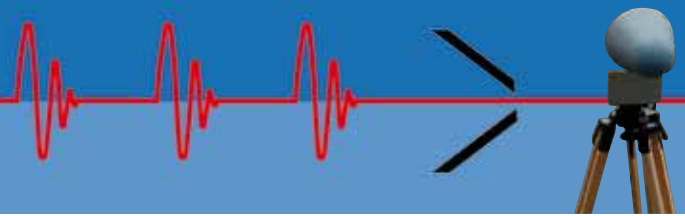

1. Sensitive magnetic field measurements

For both AC and DC fields, the surveys employ a number of techniques to assess the site's magnetic environment. EMI surveys include AC, DC, Grid Measurements, Contour Mapping, and Time Studies. Most commonly, we use is a grid configuration where the magnetic field sensors are positioned in a grid within a building area or within the rooms of interest.

Features

- Frequency range DC and 1 Hz - 3,5 kHz
- Trace typical 50 / 60 Hz sources
- DC magnetic fields
- 0.1nT to 1000uT (0.001mG tot 10 Gauss)
- Isotropic measurement in X, Y and Z directions
- Define safe limits & distances

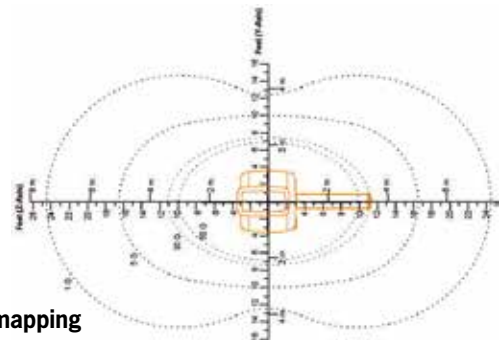

Contourmapping

2 EMF surveys / RF exposure measurement

Assessment of human or equipment exposure to both low frequency radiation generated by power lines, transformers, MRIs as well as exposure to high frequency industrial sources and telecommunication antennas like GSM and UMTS. We offer professional site assessments for institutions, hospitals, municipalities and corporations. Tests may be performed to meet ICNIRP standards or alternative health recommendations such as SBM-2008.



Features

- Magnetic DC and 1 Hz - 3.5 kHz
- Electromagnetic 9 kHz to 26 GHz and beyond
- Persons & Equipment
- GSM / UMTS / WIFI / 4G
- Define safe limits & distances

Electromagnetic field (EMF) surveys, RF Exposure & Risk Assessment

Full Spectrum Magnetic DC & AC and electromagnetic EMF surveys around the world.

Electromagnetic fields cause interference with electronics or they may affect the health of human beings. Corporations are responsible for safe working environments for their employees.

In addition, sites of sensitive equipment need to comply with the manufacturer's site specifications- this is essential for both system performance and warranties. It is important to recognize this at an early stage so that budgets are not exceeded.

Services

- Magnetic DC/AC surveys
- Electromagnetic radiation exposure limits
- Vibration / Acoustics site surveys
- Continuous monitoring

Applications

- Sensitive equipment, laboratory
- Medical / Telecom
- MRIs, EEGs and CTs
- Electron microscopes / Nano Technology
- Define RF levels at location, sick building syndrome
- Define safe limits & distances

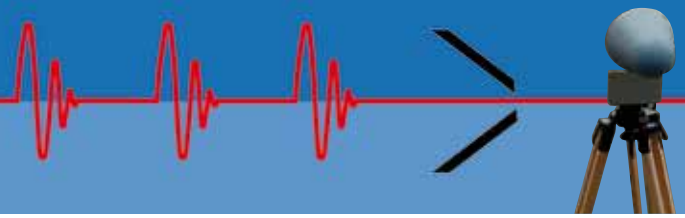

3 Continuous monitoring

We install systems for continuous monitoring and logging magnetic and electromagnetic radiation. These help to ensure that workplaces, sensitive equipment and areas in the vicinity of e.g. hospitals stay within the range of safety regulations.



Monitor station

Applications

- Comply with regulations
- Guarantee safety of employees and operators
- Reassure workers and employees
- Alert personnel
- Real estate
- Hospital

4 RF testing and RF diagnostics of products and enclosures

Shielding effectiveness acceptance tests on location and testing of materials to determine Shielding Effectiveness at Radio Frequencies. RF Testing is used to detect problems within new and existing RF enclosures, which may need periodic re-certification, such as ACR and ISO9001 accreditation. Unintentional damage may occur to the enclosure or modifications may be needed. Re-certification of the enclosure and repair of any RF leaks are essential to ensure that your shielded room is working properly.

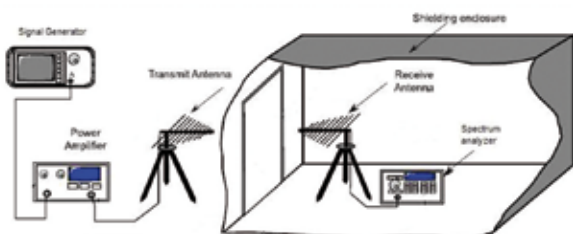

Testing shielding effectiveness

- Shielding effectiveness acceptance tests
- Custom Enclosures
- NEMP / MIL-STD
- TEMPEST compliance
- Site compliance
- (Re-) Certification ARC / ISO 9001
- Radar protection test
- Products testing for Windows, Ventilation Panels, Sheet Materials and Gaskets / Seals

5 Magnetic emission product testing

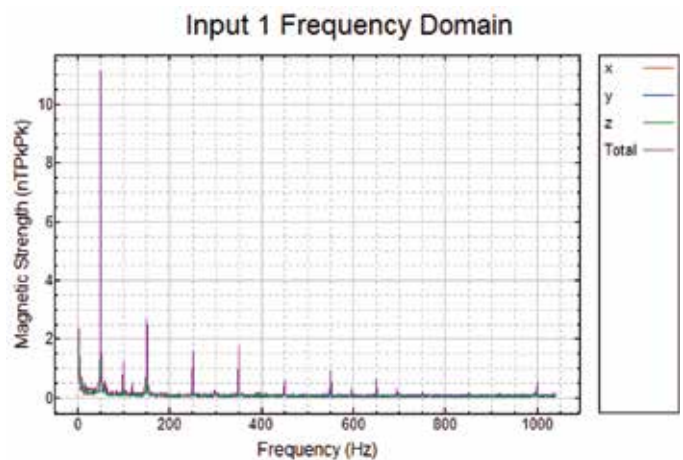

Aeronautic, defense and other sensitive laboratory products are subject to emission limitations for both DC and AC magnetic fields. We offer accurate emission testing for magnetic radiation, ranging from DC (0Hz) to 3.5 kHz, with 0.1 nanoTesla sensitivity.