

HYGROS-TEC III

Automatic Dampening System

The system consists of a detection probe for sensing the basic characteristics of the incoming product, a flow weighing plate and a damping unit control for controlling, dosing and adding water. The detection probe is able to instantly determine the hectoliter weight, temperature and constant dielectric of the incoming product and to elaborate the data determining the percentage of water present in the product. The HYGROS-TEC III system is suitable for a production up to 30 t/h with water addition up to a maximum of 2500 l/h.

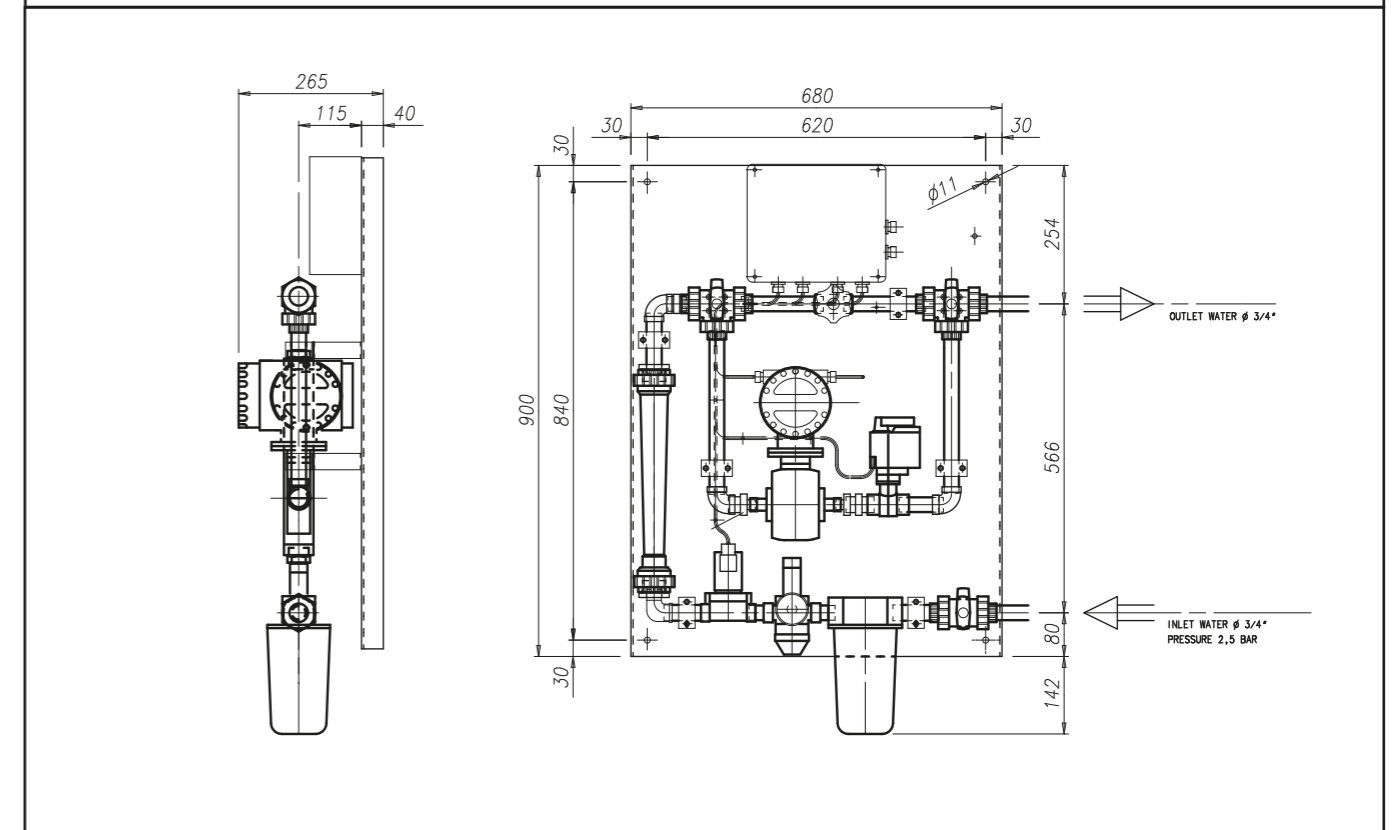
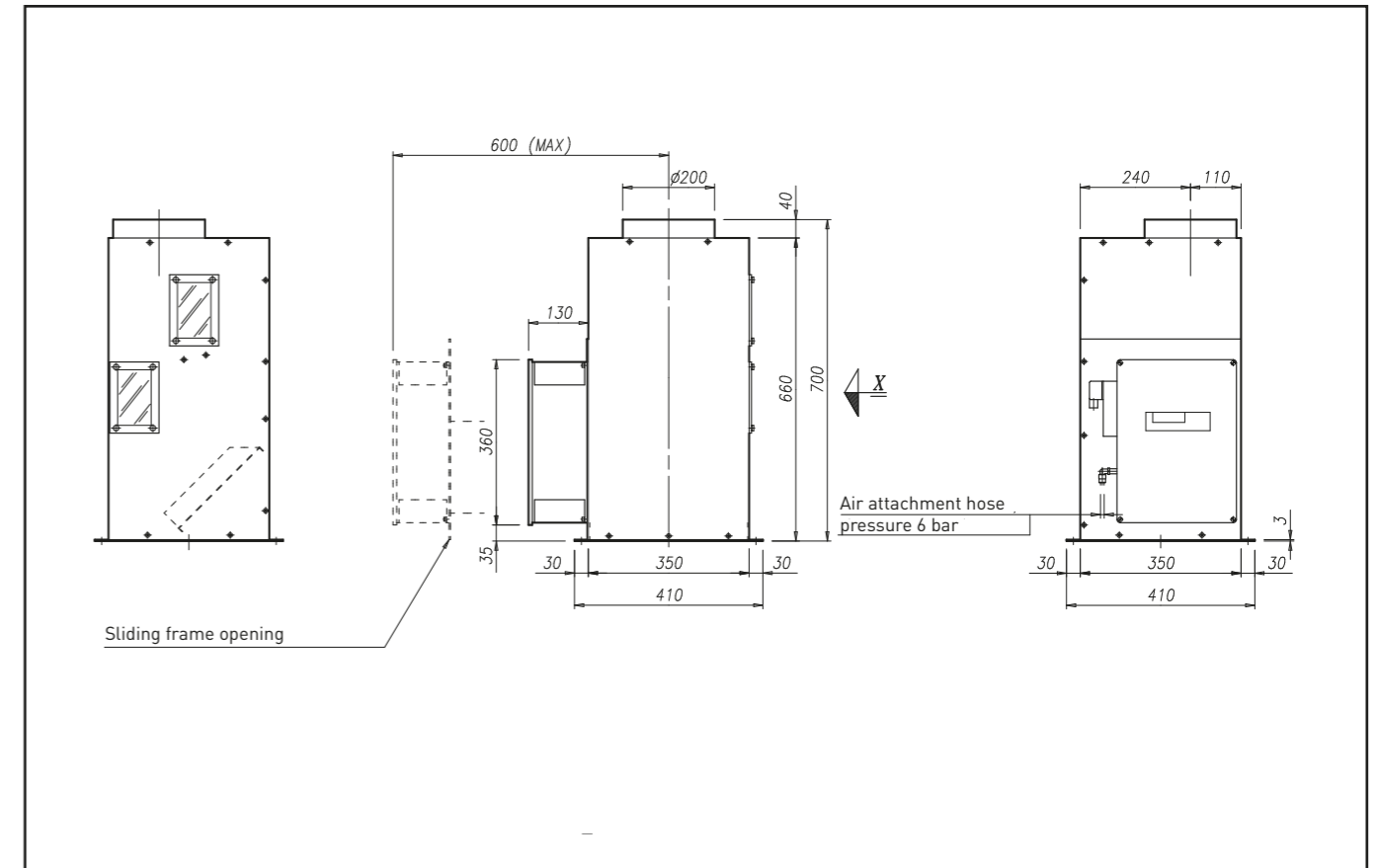

Units = mm