

RFP

Ponderal Flow Measurer

Weighing control, dosing, cereal blending. Set up of the capacity per hour for each single RFP can be executed directly on the machine or remotely via computer thanks to a serial connection RS 485 or, optionally, PROFIBUS.

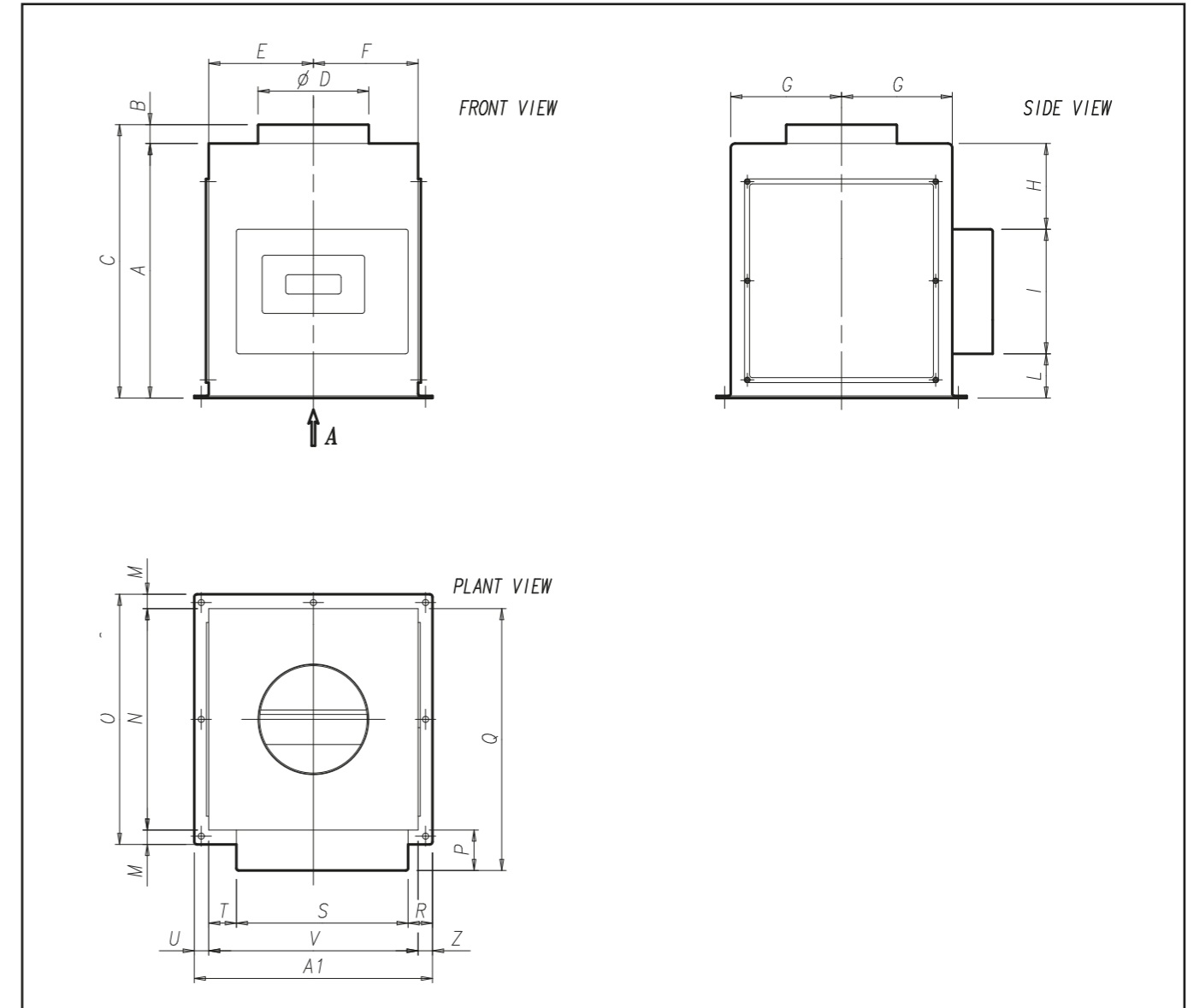

Model	Capacity* t/h	A	B	C	D	E	F	G	H	I	L	P	Q	R	S	T
RFP10	2-5-10	385	30	415	120	155	155	145	-	255	130	130	420	-	310	-
RFP30	20-30	385	30	415	200	155	155	205	-	255	130	130	540	-	310	-
RFP100	60-100	580	40	620	300	195	235	350	205	255	120	131	831	16	305	109

Model	U	V	Z	A1
RFP10	20	310	-	330
RFP30	20	310	-	330
RFP100	30	430	30	490

* Soft wheat 0,75t/m³
Units = mm