

ROLBOX 200

LABELLING AND BANDEROLLING MACHINE FOR ROUND BOXES

Mechanical speed : 240 boxes / min
90% guaranteed efficiency : 216 boxes / min

 Made in FRANCE



« ROLBOX, high speed and reliable labelling-banderolling machine, designed for round cheese boxes »

- ROLBOX 200 machine is dedicated to the labelling and the banderolling of round processed cheese boxes.
- ROLBOX 200 capacity up to 240 boxes / min, with adjustable height from 15 to 70 mm.
- ROLBOX 200 is composed of 2 independent banderolling lines : one can run even if the second is stopped.
- Conveyor arrival in front of the machine can either be on 1 or 2 channels
- ROLBOX 200 has the followings characteristics :
 - Compact machine
 - Reduced adjustment time for a new box size settings
 - Simplified maintenance operations
 - Labelling unit as an option
 - Cold glue, opening string, paper banderol

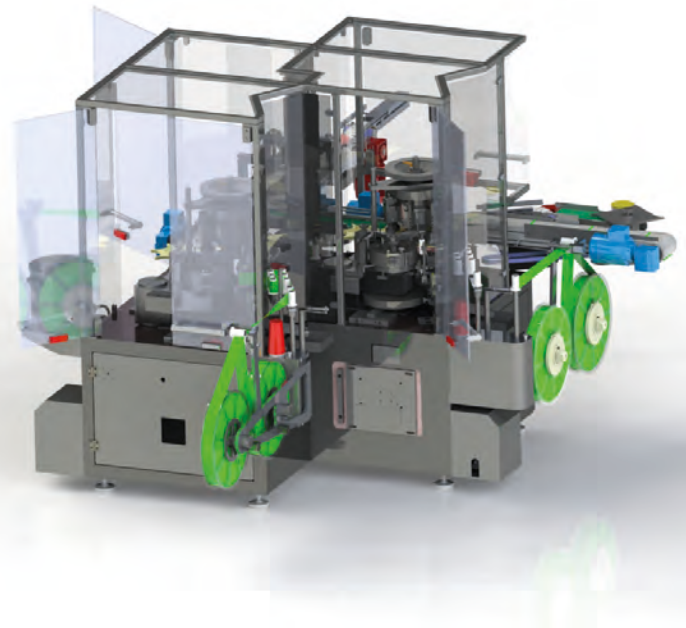

TECHNICAL SPECIFICATIONS

| | |
|---------------------|--|
| Dimensions of boxes | Ø 111mm - adjustable height from 15 to 70 mm (from 1 to 4 layers of triangles) |
| Weight | 2,4 tons |
| Power consumption | electricity : 6 kWh |
| | compressed air : 12m ³ h at 6 bars |



Rue Roger Thirode - 39800 POLIGNY - France
Tél. : +33 (0)3 84 37 24 12 - Fax : +33 (0)3 84 37 05 57 - gma@gma-france.com

www.gma-france.com



ROLBOX 200

LABELLING AND BANDEROLLING MACHINE FOR ROUND BOXES

Mechanical speed : 240 boxes / min
90% guaranteed efficiency : 216 boxes / min

 Made in FRANCE

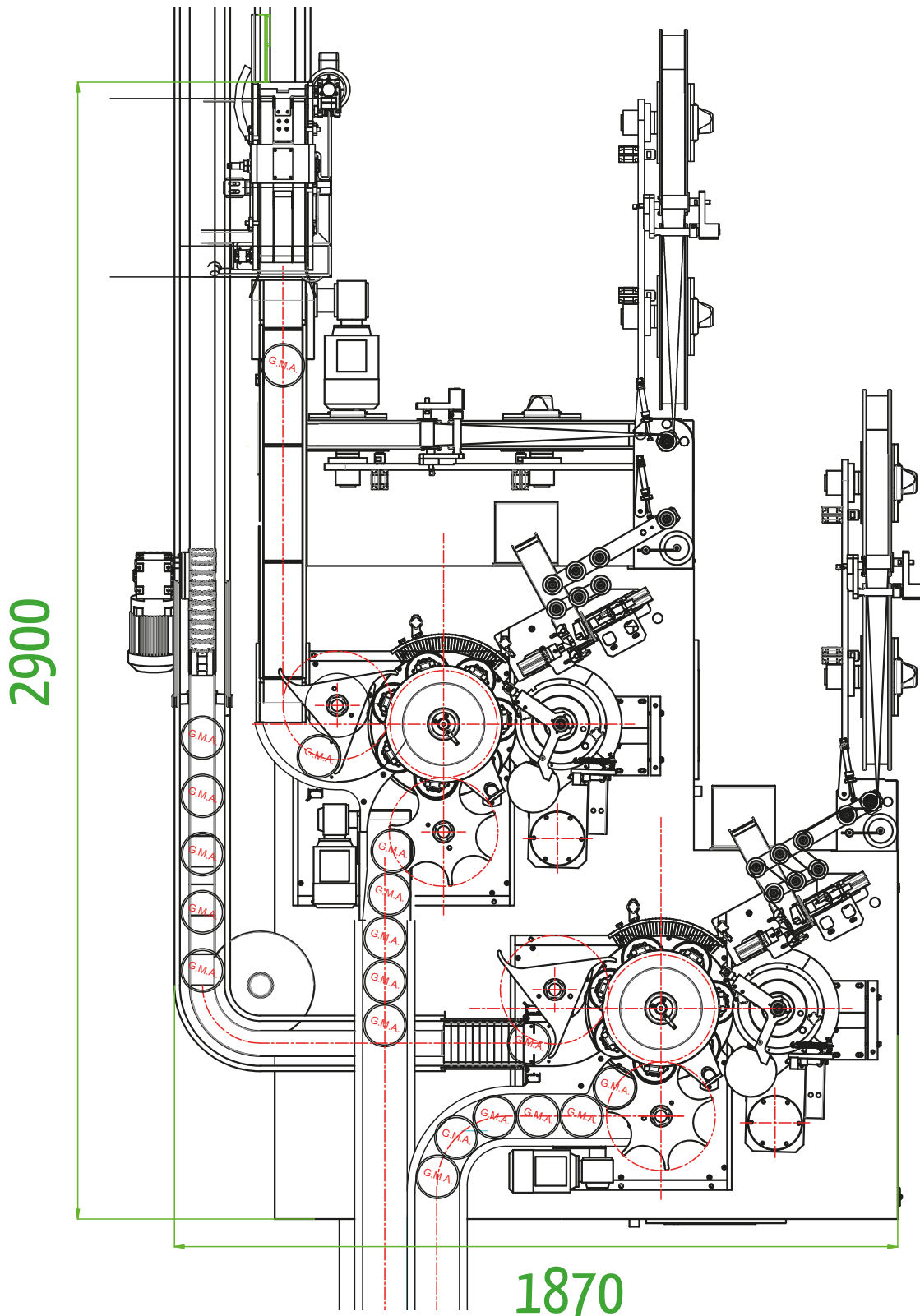

Indicative and non contractual layout.