



Big Foot 280

Reference Code
MCO17



Big Foot 450

Reference Code
MCO12

Big Foot 280 & Big Foot 450

[280kg & 450kg]

The highly manoeuvrable Big Foot floor cranes feature rough terrain solid tyres that enable loads to be easily shifted across uneven ground.

These special floor cranes are simple to assemble and disassemble, with removable counterbalance weights for convenient transportation. Available with either 280kg or 450kg safe working load.

Key Features

- Rough terrain wheeled crane
- Big Foot 280 maximum hook height: 2.6m
- Big Foot 450 maximum hook height: 2.7m
- Big Foot 450 small wheel diameter: 250mm
- Big Foot 450 larger wheel diameter: 400mm

Technical Specifications	280	Arm Extension	450	Arm Extension
Capacity Position 1	280kg	830mm	450kg	560mm
Capacity Position 2	250kg	950mm	390kg	680mm
Capacity Position 3	220kg	1070mm	330kg	800mm
Capacity Position 4	190kg	1190mm	280kg	920mm
Weight (w/ counterweights)	446kg		564kg	
Weight (w/o counterweights)	160kg		168kg	
Counterweights	13		18	
Transport dimensions (folded)	1650mm (l) 780mm (w) 700mm (h)		1720mm (l) 780mm (w) 700mm (h)	

Technical Data

Big Foot 280

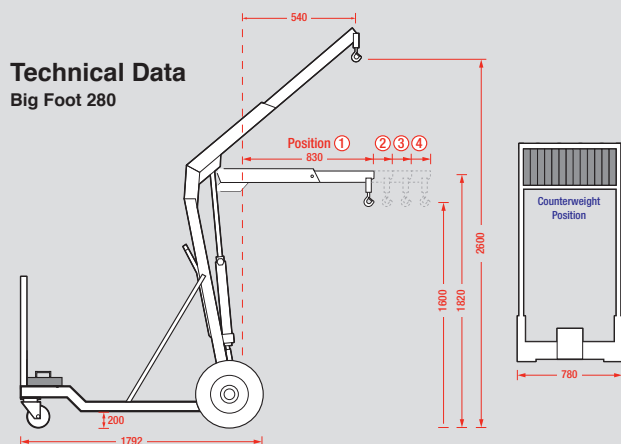

Note: Counterweights must be secured before lifting

Technical Data

Big Foot 450

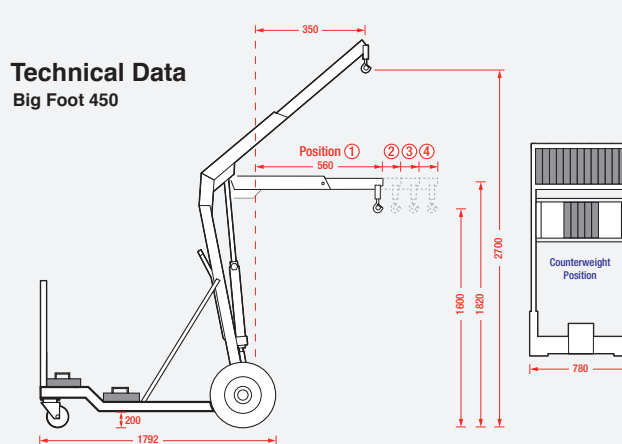

Note: Counterweights must be secured before lifting

Big Foot 450 Hydraulic [450kg]

This Big Foot 450 floor crane comes with a 12V hydraulic jib that offers multiple adjustments for effortless handling of loads up to 450kg.

The hydraulic jib comes with two speeds and can be lowered with millimetre accuracy using the cable remote control. Perfect for glazing projects when combined with one of our vacuum lifters.

Weight: 680kg.

Reference Code

MCO02

Note: Counterweights must be secured before lifting

