

GENSCO

VERTICAL BALERS

*Workhorses
of the Industry*



Solid Performance You Can Depend On, Year After Year

Max-Pak's Vertical Balers are known for their work ethic...year after year, after year. And it's no wonder, with Max-Pak's heavy duty construction and our better-than-it-has-to-be approach to electrical and hydraulic components. The first balers we ever made were Verticals, and we learned how to build them the right way by putting our balers to work in our own

recycling facility. It's fair to say we KNOW Vertical balers, and our customers benefit from that knowledge every day. With 11 different models to choose from, Max-Pak has a Vertical baler to fit your needs – a solid, dependable workhorse for many years to come.

Side Mount Vertical Balers Offer A New Standard in Serviceability

The Max-Pak Vertical Side Mount balers now offer superior ease of access to power unit components, including the oil tank, motor, hydraulic valve, control panel and junction box. A simple 4-bolt mount allows removal of the entire power unit in minutes for service. Power Unit "cores" may also be returned to Max-Pak for full factory refurbishment, and a core replacement program is available.

The new "Quick Exchange" Power Units are standard on the MP60HD-15 and available on most Max-Pak Vertical Balers.



The Max-Pak Vertical Side Mount power unit features easy service access. Most components can be reached without the use of a ladder, and simple 4-bolt mounting allows removal of the entire unit in minutes.



Max-Pak vertical balers now feature a touch screen interface for operator controls and user feedback...the first of its kind in the industry.



Our vertical balers are designed to survive years of punishment, with structural features like 12-inch header beams and 10-inch side channels.



Tube steel reinforces the discharge door and maintains the integrity of the bale chamber. Other balers typically use channel steel for the discharge door.

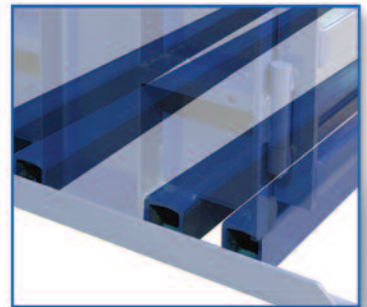

Subfloors are constructed of 4 pieces of 4-inch tube steel, for the best foundation in the industry.



Platen roller guides ensure smooth operation.

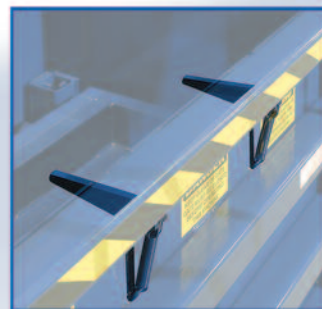

Spring loaded 6-inch dawgs maintain bale integrity during baling process.



10-inch ratchet wheel is easier to operate than 6 or 8-inch wheels.

MAX-PAK VERTICAL BALER SPECIFICATIONS

BALER MODEL	BALE SIZE	BALE WEIGHT (lbs.)	CYCLE TIME (No Load)	MOTOR	PUMP	CYLINDER	SYSTEM PRESSURE	RAM PRESSURE	PLATEN PRESSURE	OIL CAPACITY	SHIPPING WEIGHT (Approx)
MP48HD-10	30 x 48 x 48	Up to 900	60 Seconds	10hp 208/230/460v 3ph	9.8 GPM	6" Bore 3.5" Rod 48" Stroke	2200 PSI	62,203 lbs.	48.29 PSI	30 Gallons	4700 lbs.
MP48HD-15	30 x 48 x 48	Up to 1,000	47 Seconds	15hp 208/230/460v 3ph	12.5 GPM	6" Bore 3.5" Rod 48" Stroke	2350 PSI	66,444 lbs.	51.59 PSI	30 Gallons	4700 lbs.
MP4820-66-7	30 x 48 x 48	Up to 1,100	65 Seconds	20hp 208/230/460v 3ph	16.1 GPM	7" Bore 4.5" Rod 66" Stroke	2350 PSI	90,438 lbs.	70.22 PSI	41 Gallons	5300 lbs.
MP60HD-10	30 x 48 x 60	Up to 1,000	60 Seconds	10hp 208/230/460v 3ph	9.8 GPM	6" Bore 3.5" Rod 48" Stroke	2200 PSI	62,203 lbs.	38.30 PSI	30 Gallons	5000 lbs.
MP60HD-15	30 x 48 x 60	Up to 1,100	47 Seconds	15hp 208/230/460v 3ph	12.5 GPM	6" Bore 3.5" Rod 48" Stroke	2350 PSI	66,444 lbs.	40.91 PSI	30 Gallons	5000 lbs.
MP6020-66-7	30 x 48 x 60	Up to 1,200	65 Seconds	20hp 208/230/460v 3ph	16.1 GPM	7" Bore 4.5" Rod 66" Stroke	2350 PSI	90,438 lbs.	55.69 PSI	41 Gallons	6700 lbs.
MP6020-52-8	30 x 48 x 60	Up to 1,300	64 Seconds	20hp 208/230/460v 3ph	16.1 GPM	8" Bore 5.5" Rod 52" Stroke	2350 PSI	118,124 lbs.	72.74 PSI	60 Gallons	9500 lbs.
MP7230	30 x 48 x 72	Up to 1,100	47 Seconds	15hp 208/230/460v 3ph	12.5 GPM	6" Bore 3.5" Rod 48" Stroke	2350 PSI	66,444 lbs.	33.90 PSI	30 Gallons	5400 lbs.
MP7242	42 x 48 x 72	Up to 1,350	47 Seconds	20hp 208/230/460v 3ph	16.1 GPM	7" Bore 4.5" Rod 48" Stroke	2350 PSI	90,438 lbs.	32.30 PSI	41 Gallons	6900 lbs.

MEASUREMENTS (inches)

MODEL	A	B	C	D	E	F	G	H	I
MP48HD-10	55	66	52.75	101	143	45	93	76	54
MP48HD-15	55	66	52.75	101	143	45	93	76	54
MP4820-66-7	55	66	52.75	101	164	45	93	76	54
MP60HD-10	67	78	52.75	101	143	45	105	76	54
MP60HD-15	67	78	52.75	101	143	45	105	76	54
MP6020-66-7	67	78	52.75	101	164	55	105	76	54
MP6020-52-8	67	78	52.75	101	150	55	105	76	54
MP7230	79	90	52.75	101.5	143	45	117	76	54
MP7242	79	90	52.75	104.5	143	60	125	76	69

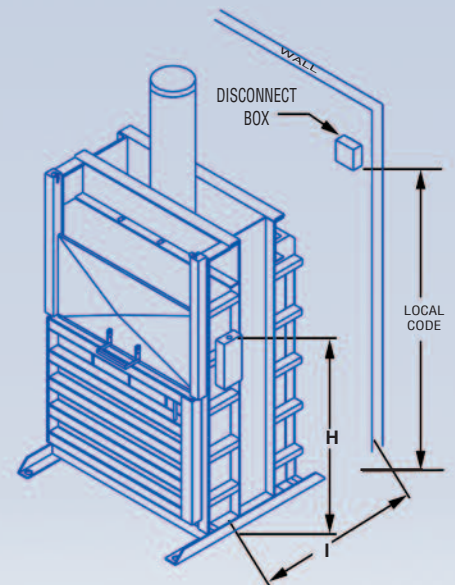
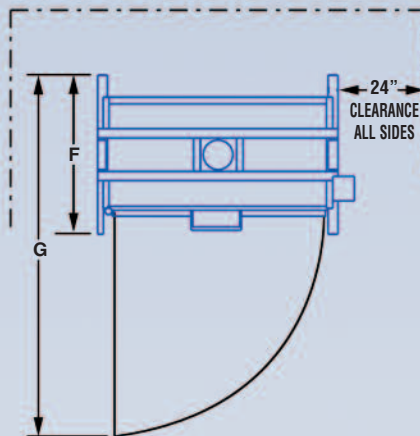
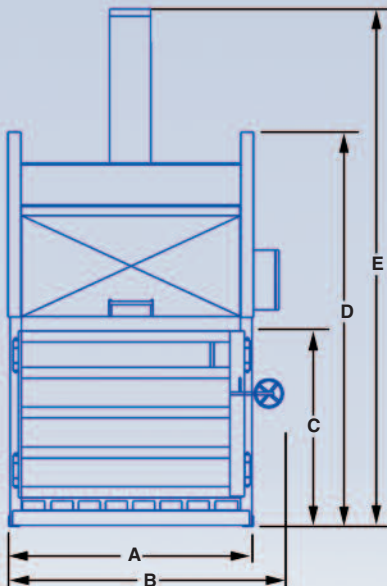

The Max-Pak Difference

Since 1976, Max-Pak has been making quality balers and compactors for the waste industry. It was something we had to do. You see, we're also in the waste paper recycling business, and 32 years ago we couldn't find a baler that performed the way we needed. So we built our own.

Being in the waste business has its advantages when you're designing a baler. Not only do we understand the challenges and demands expected from a baler, we get to test and fine tune our ideas in a real working environment – our own.

For our other baler customers, it means they get the benefit of our front-line experience and our determination to build only the best. A Max-Pak baler is not good enough for our customers unless it's good enough for us.

At Max-Pak we take a personal interest in every machine we sell, and every customer we serve. It comes from our small town heritage. It's who we are. So it also makes sense that we deliver and install every baler ourselves, and then train your operators before we leave. We want you to be a friend and a Max-Pak customer for a long time. That's part of our small town, small company mentality.

But make no mistake. Max-Pak is no lightweight when it comes to balers. You'll find our equipment in some of the most demanding industries, with some of the most particular companies.

Our customers have come to know and trust Max-Pak for productivity, reliability, and integrity. So it's no surprise that over 90% of all Max-Pak balers ever built are still on the job. And we plan to keep it that way.

Max-Pak Offers A Full Line of Baling and Recycling Equipment

Call Us For More Information, or to Locate Your Nearest Dealer.



Auto-Tie Balers



Full Eject Balers



Two-Ram Balers

Horizontal Closed End Balers



Stamper Full Eject Balers



Foam and Fiber Balers



Compactors



Answer Two-Ram Baler

Since 1919

GENSCO

GENSCO AMERICA, INC

5307 Dividend Dr., Decatur, Georgia 30035 • Tel: 770 808-8711 • Fax: 770 808-8739

GENSCO EQUIPMENT (1990) Inc

53 Carlaw Ave., Toronto, Canada M4M 2R6 • Tel: 416 465-7521 • Fax: 416 465-4489

email: info@genscoequip.com • www.genscoequip.com



ACROSS USA 800 268-6797