

Model	Capacity @ 500 mm LC	Fuel Type	Engine
CPCD30	3,000 kg	Diesel	Xinchai A490BPG / 2.54 L
CPCD30	3,000 kg	Diesel	ISUZU AK-C240PKJ-YANMAR / 2.37 L
CPCD30	3,000 kg	Diesel	YANMAR 4TNE98 - BQFLC / 3.318 L

CPCD30

Diesel
Pneumatic Tire Forklifts



TOUGH WORLD. TOUGH EQUIPMENT.

CPCD30 Diesel • Pneumatic Tire Forklifts



General	1	Model			CPCD30	CPCD30	CPCD30
	2	Power Type			Diesel	Diesel	Diesel
	3	Base Capacity	@rated load center	kg	3,000	3,000	3,000
	4	Load Center		mm	500	500	500
Weights	5	Service Weight	unloaded	kg	4,230	4,230	4,230
	6	Axle Load	loaded / unloaded, front	kg	6,370 / 1,660	6,370 / 1,660	6,370 / 1,660
	7		loaded / unloaded, rear	kg	860 / 2,570	860 / 2,570	860 / 2,570
Tires	8	Tire Type			Pneumatic	Pneumatic	Pneumatic
	9	Wheels	front / rear		2 / 2	2 / 2	2 / 2
	10	Wheelbase		mm	1,700	1,700	1,700
	11	Tire Size	front		28x9-15-12PR	28x9-15-12PR	28x9-15-12PR
	12		rear		6.50-10-10PR	6.50-10-10PR	6.50-10-10PR
13	Tread Width	front / rear		1,000 / 980	1,000 / 980	1,000 / 980	
Mast	14	Max. Fork Height	with std 2-stage mast	mm	3,000	3,000	3,000
	15	Free lift	with std 2-stage mast	mm	145	145	145
	16	Height, Upright Lowered	with std 2-stage mast	mm	2,080	2,080	2,080
	17	Height, Upright Extended	with std 2-stage mast	mm	4,146	4,146	4,146
	18	Mast Tilt, Fwd/Back	with std 2-stage mast	deg	6° / 12°	6° / 12°	6° / 12°
	19	Carriage	width	mm	1,100	1,100	1,100
	20	Fork Spread	minimum / maximum	mm	272 / 1,072	272 / 1,072	272 / 1,072
21	Fork Dimensions	T x W x L	mm	45 x 122 x 1,070	45 x 122 x 1,070	45 x 122 x 1,070	
Chassis	22	Length to Fork Face	with std 2-stage mast	mm	2,705	2,705	2,705
	23	Overall Width		mm	1,225	1,225	1,225
	24	Overhead Guard Height		mm	2,125	2,125	2,125
	25	Turning Radius	minimum outside	mm	2,400	2,400	2,400
	26	Fork Overhang	with std 2-stage mast	mm	471	471	471
	27	Right Angle Stack	add load length and clearance	mm	4,141	4,141	4,141
	28	Ground Clearance	minimum loaded	mm	135	135	135
29	center of wheelbase		mm	140	140	140	
Performance	30	Travel Speed	loaded / unloaded	km/h	18.5 / 19	18.5 / 19	18.5 / 19
	31	Lift Speed	loaded / unloaded	m/s	0.43 / 0.45	0.43 / 0.45	0.43 / 0.45
	32	Lower Speed	loaded / unloaded	m/s	0.46 / 0.4	0.46 / 0.4	0.46 / 0.4
	33	Max. Drawbar Pull	loaded	kg	1,650	2,000	2,000
	34	Max. Gradeability	loaded / unloaded	%	18 / 20	18 / 20	20 / 20
Systems	35	Brakes	service		Foot / Hyd	Foot / Hyd	Foot / Hyd
	36		parking		Hand / Mech	Hand / Mech	Hand / Mech
	37	Engine	manufacturer		Xinchai	ISUZU	YAMMAR
	38		model		A490BPG	AK-C240PKJ-30	4TNE98-BQFLC
	39	Engine	emission compliance		China Tier II	Euro Tier III	EPA / Euro Tier III
	40		cylinders		4	4	4
	41		displacement	liters	2.54	2.369	3.318
	42		rated power	kW/rpm	36.8 / 2,650	35.4 / 2,500	42.1 / 2,300
43	Max. torque		N · m/rpm	148 / 1,900	137.7 / 1,800	196.3 / 1,700	

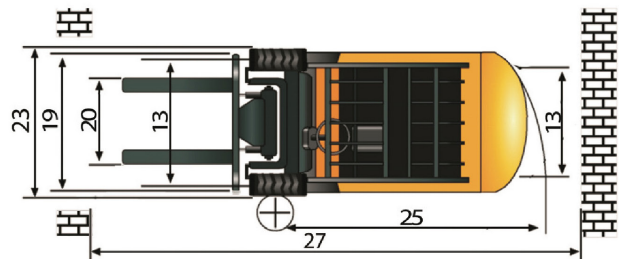
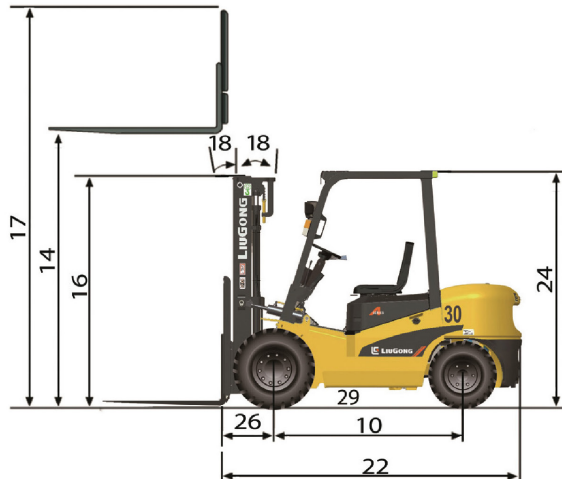

Guangxi Liugong Machinery Co., Ltd.

No. 1 Liutai Road, Liuzhou, Guangxi 545007, PR China
 T: +86 772 3886124 E: overseas@liugong.com
 www.liugong.com

02/2014 Designed by Liugong