

Engine	Cummins
Gross Power	97 kW (130 hp) @ 2,200 rpm
Net Power	87.3 kW (117 hp) @ 2,200 rpm
Operating Weight	11,500 kg
Standard Bucket Size	1.7 m ³
Standard Breakout Force	93.5 kN
Standard Dump Clearance	2,911 mm

CLG835 Wheel Loader



TOUGH WORLD. TOUGH EQUIPMENT.

ENGINE

Emission Regulation	Tier 2 / Stage II
Make	Cummins
Gross Power	97 kW (130 hp) @ 2,200 rpm
Net Power	87.3 kW (117 hp) @ 2,200 rpm
Peak Torque	580 N · m @ 1,400 rpm
Displacement	5.9 L
Number of Cylinders	6
Aspiration	Turbocharged

TRANSMISSION

Transmission Type	planetary power shift
Torque Converter	double-stage, four-element
Maximum Travel Speed, fwd	36 km/h
Maximum Travel Speed, rev	15 km/h
Number of Speeds, fwd	2
Number of Speeds, rev	1

AXLES

Differential Front Type	conventional
Differential Rear Type	conventional
Axle Oscillation	±7°

STEERING

Steering Configuration	articulated
Steering Relief Pressure	14 Mpa

BRAKES

Service Brake Type	caliper dry disc
Service Brake Actuation	air over hydraulic
Parking Brake Type	Manual Pneumatic Control
Parking Brake Actuation	Air

HYDRAULIC SYSTEM

Main Pump Type	gear
Main Relief Pressure	16 MPa
Raise	4.9 s
Fastest Total Cycle Time	9.3 s

LOADER ARM PERFORMANCE

Tipping Load - Straight	8,622 kg
Tipping Load - Full Turn	7,551 kg
Bucket Breakout Force	93.5 kN
Maximum Dump Angle at Full Height	45°
Dump Clearance at Full Height Discharge	2,911 mm
Dump Reach at Full Height Discharge	1,080 mm
Maximum Hinge Pin Height	3,721 mm
Maximum Digging Depth, Bucket Level	35 mm
Bucket Rollback at Ground Level	40°
Bucket Rollback at Carry	45°
Bucket Rollback at Maximum Height	60°

BUCKET PERFORMANCE

Reference Bucket	1.7 m ³
------------------	--------------------

DIMENSIONS

Length with Bucket Down	7,000 mm
Width Over Tires	2,300 mm
Wheelbase	2,900 mm
Wheel Tread	1,850 mm
Ground Clearance	312 mm
Turn Angle, Either Side	40°
Rear Angle of Departure	30°
Turning Radius, Outside of Tire	5,135 mm
Turning Radius, Center of Tire	4,910 mm
Turning Radius, Bucket Carry	5,660 mm

TIRES

Tire Size	17.5 - 25
-----------	-----------

OPERATING WEIGHTS

Operating Weight	11,500 kg
------------------	-----------

SERVICE CAPACITIES

Fuel Tank	180 L
Engine Oil	17 L
Cooling System	53 L
Hydraulic Reservoir	150 L
Transmission and Torque Converter	45 L
Front Axle	20 L
Rear Axle	24 L

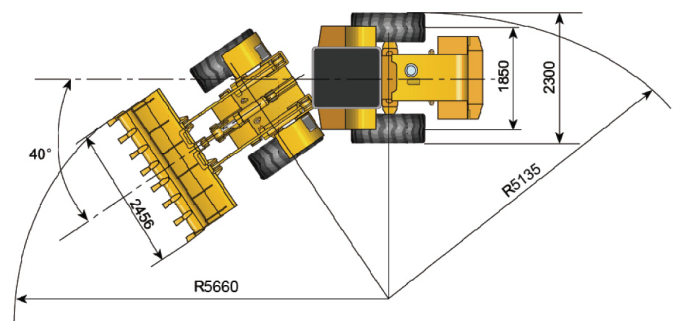
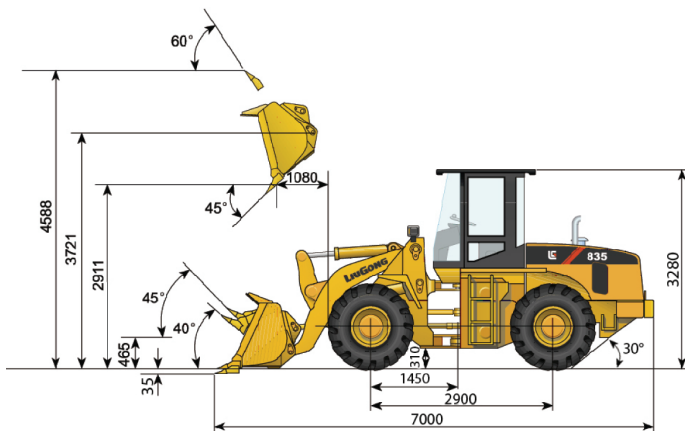

Guangxi Liugong Machinery Co., Ltd.

No. 1 Liutai Road, Liuzhou, Guangxi 545007, PR China
 T: +86 772 3886124 E: overseas@liugong.com
 www.liugong.com