



esiMot

Decentral Servo - Drive

- Brushless servo-motor with integrated electronics
- Positioning and speed-/torque regulator mode
- Digital 4-Q regulator
- Direct status- and diagnostics function through LED's
- Digital inputs and outputs (24V)
- RS232 for parameter setting
- 24 - 60V DC motor supply
- Separate logic supply 24V, wrong polarity protected

Order-Options:

- Set value analog
+/- 10V DC / 0 ... 10 V DC with direction signal
0/4 ... 20 mA
- Recordable drive records (PLC-interface)
- Galvanically insulated fieldbus interface:
Profibus-DP
PROFINET
CANopen DSP402
EtherCAT CoE
Modbus RS485
Bus address and baud rate adjustable via switch
- Safe Torque Off Cat. 3 Performance level e
- Multiturn absolute encoder (built-in)
- Standstill brake
- ATEX114, Zone 2 and 22
- Planetary and worm-gearboxes

all-in-one
Servomotor
highly dynamic
120 - 600 W



ATEX 114

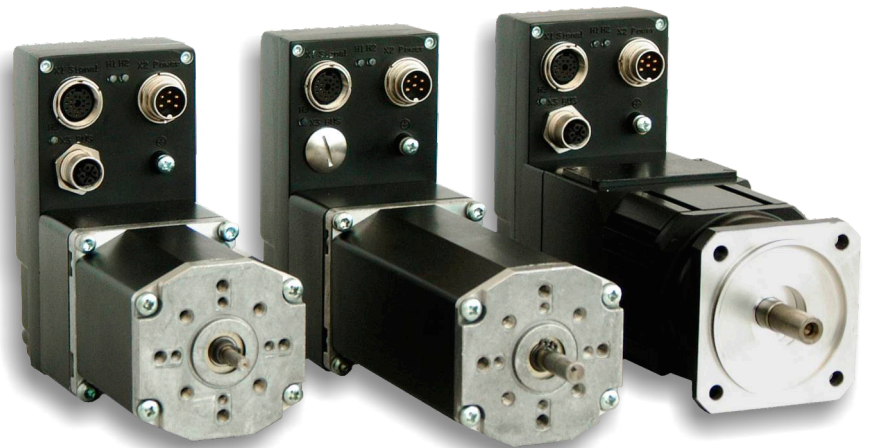

esiMot Features

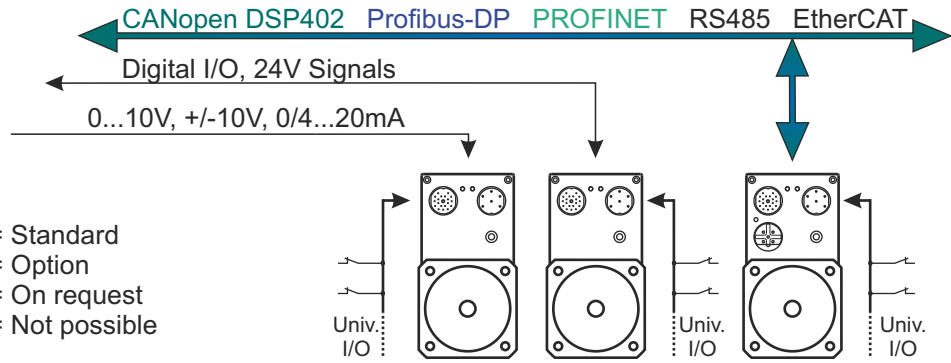

- ✓ = Standard
- = Option
- ◇ = On request
- = Not possible

esiMot-Type	Without Fieldbus		With Fieldbus
	esiMot x/x.1xx.xx Amplifiermode	esiMot x/x.2xx.xx Positioningmode	esiMot x/x.3-7xx.xx All modes
Integrated servo-amplifier	✓	✓	✓
Integrated positioning logic (position loop)	-	✓	✓
Digital 4Q speed and torque regulator	✓	✓	✓
Position acquisition			
- Incremental encoder* (Standard with esiMot7)	□	□	□
- Absolute encoder Multi-Turn	□	□	□
Fieldbus RS485, CANopen, Profibus-DP, Profinet	-	-	□
Analog set value	✓	-	□
Digital inputs	4	8	4 / ◇6
Digital outputs	1	2	2 / ◇4
Encoder output A/B/0 24V	✓	-	◇
Integrated ballast circuit and -resistor	✓	✓	✓
Connection for external ballast resistor	✓	✓	✓
Wrong polarity protection	✓	✓	✓
Stand still brake	□	□	□
RS232 Programming interface (19,2kBaud)	✓	✓	✓

Functions and Programming	Programming/Parameter setting		
	esiMot x/x.1xx.xx	esiMot x/x.2xx.xx	esiMot x/x.3-7xx.xx
- via RS232 Interface	✓	✓	✓
- via Fieldbus RS485, CANopen, Profibus-DP, Profinet	-	-	✓
- Position-Teach-In	-	✓	-
Reference run management	-	✓	✓
Limit switch (Hard- and Software)	-	✓	✓
Automatic brake management	□	□	□
Free programmable move records	-	15	15
- Velocity	-	✓	✓
- Acceleration/Deceleration (separate adjustable)	-	✓	✓
- On-the-fly record change	-	✓	✓
- Dwell time	-	✓	✓
- Set outputs (M-functions)	-	✓	✓
Regulating modes			
- Electronic shaft/electronic gear	-	✓	✓
- Speed / Torque (PI-Regulation)	✓	✓	✓
- Absolute, Relative, Modulo Position (P-Regulation)	✓	✓	✓

Monitoring	Status LEDs		
	esiMot x/x.1xx.xx	esiMot x/x.2xx.xx	esiMot x/x.3-7xx.xx
Signalling e.g. for:			
- Motor temperature (I ² t)	✓	✓	✓
- Motor temperature PTC (at esiMot7)	✓	✓	✓
- Output stage temperature	✓	✓	✓
- Ballast power internal	✓	✓	✓
- Overvoltage/Undervoltage	✓	✓	✓
Elapsed hour meter	✓	✓	✓
Electronic type plate	✓	✓	✓

Accessories	Programming and parametrizing PC-software ServoLink			
	esiMot x/x.1xx.xx	esiMot x/x.2xx.xx	esiMot x/x.3-7xx.xx	
	Assembled feed cable	□	□	□
	Fitted gear boxes	□	□	□
RS232-Adapter	□	□	□	

* Resolution see motor-data

Without Fieldbus

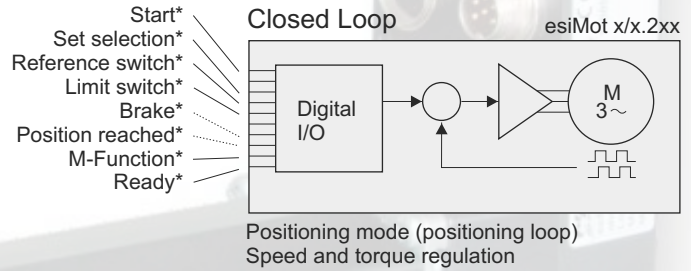
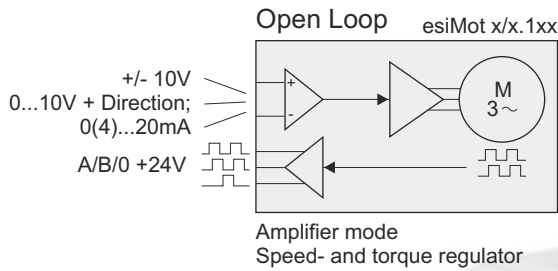

With Fieldbus

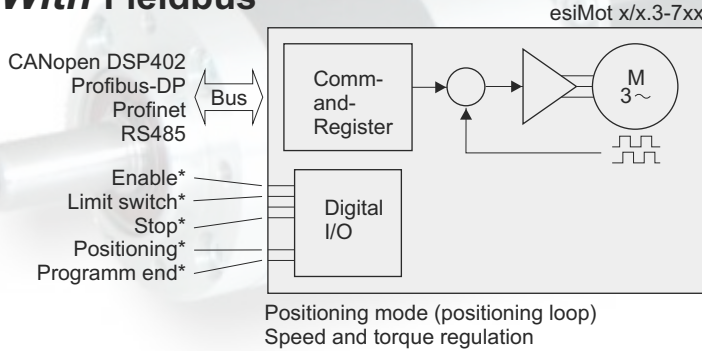

*) Example connection;
other I/O-Functions are assignable.

Sample-Driveprofile:

On-the-fly record change

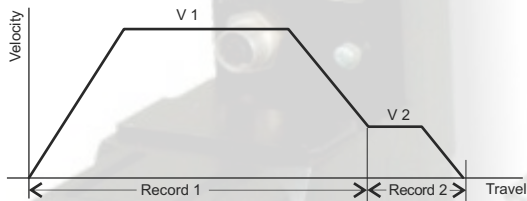

Record change with intermediate stop

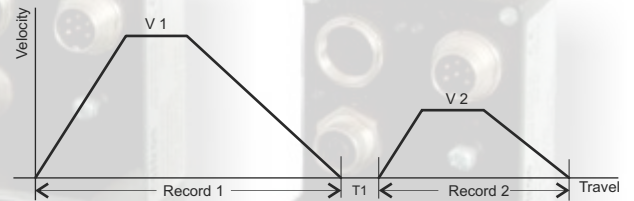

PC-Software:

User settings

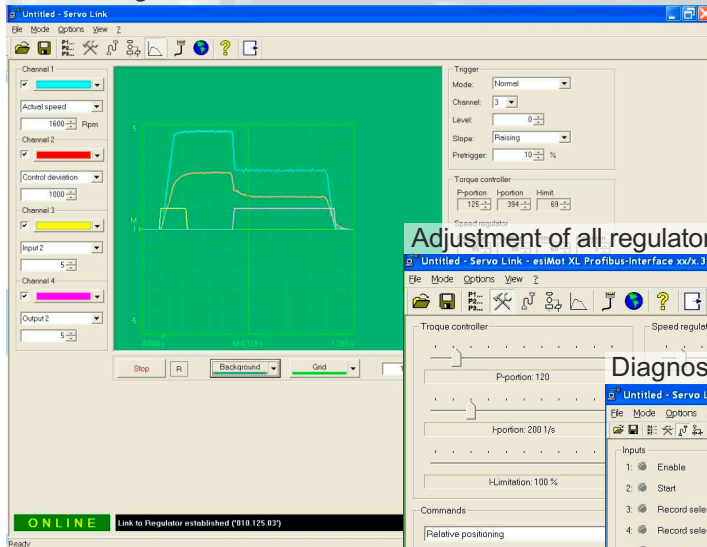

I/O-Configuration

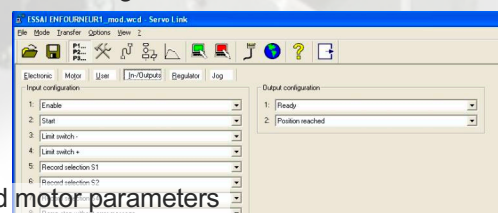

Adjustment of all regulator and motor parameters

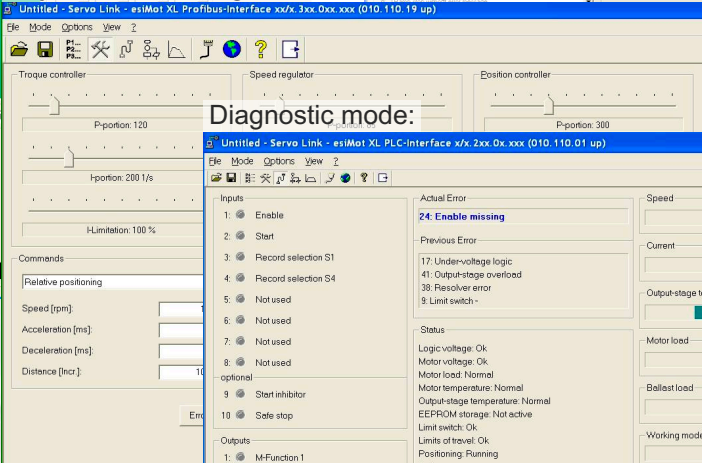

Other features:

- Display units mm, °, ...
- Project management
- Password protection
- User settings
- Oscilloscope
- Language selection German/English

Technical Data:

		24V		48V			60V	
esiMot size		6/1	6/2	6/5	7/1	7/2	7/1	7/2
Motor power (S3)	[W]	120	180	260	500	400	600	480
Rated power	[W]	70	110	200	340	300	430	380
Nominal torque	[Nm]	0,22	0,35	0,65	1,1	1,8	1,1	1,8
Impulse torque	[Nm]	0,50	0,70	1,2	1,6	2,3	1,6	2,3
Rated speed	[min ⁻¹]	3000	3000	3000	3000	1600	3750	2000
Inertia	[gcm ²]	71,6	128	172	530	530	530	530
Motor-supply	[VDC]	24	24	48	48	48	60	60
Rated current	[A]	4,0	5,6	3,5	9,0	8,0	9,0	8,0
Peak current	[A]	14	14	14	14	14	14	14
Logic supply (0,3A)	[VDC]	24	24	24	24	24	24	24
Resolution without incr.-enc.	[lpr]	30	30	30	-	-	-	-
with integrated incr.-enc.	[lpr]	2048	2048	2048	4096	4096	4096	4096
with integrated absolute enc.	[lpr]	4096	4096	4096	4096	4096	4096	4096
Protection class (mounting specific)		IP 64	IP 64	IP 64	IP 64	IP64	IP64	IP64
Weight ca.	[kg]	1,37	1,8	2,3	2,3	2,3	2,3	2,3

Dimensions:

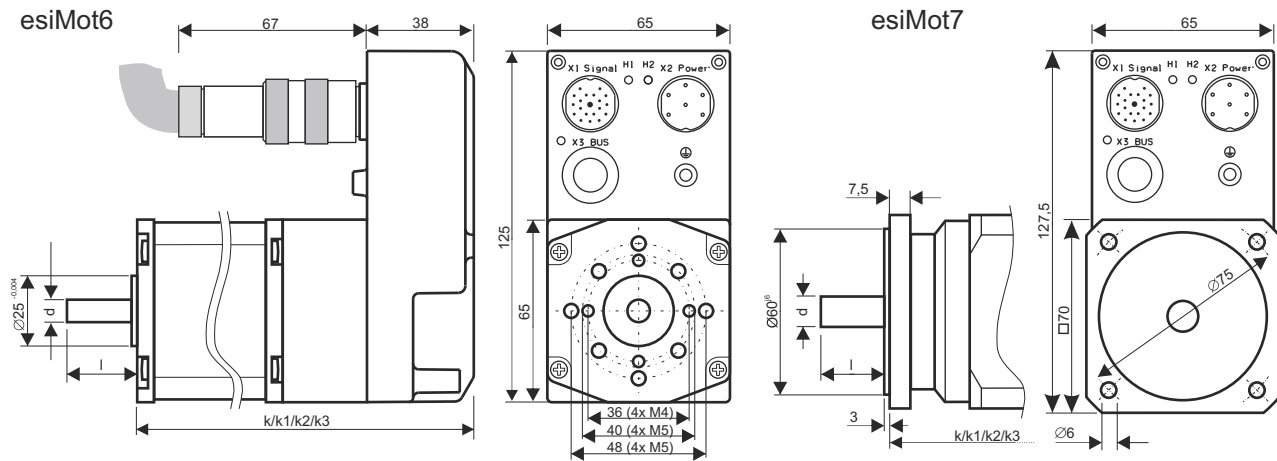

esiMot	d	l	k	k1	k2	k3
6/1	5	20	148	188	188	on request
6/2	5	20	173	213	213	on request
6/5	8	25	198	238	238	on request
7/x	11	20	186	236	199	249

k = Hall sensors / incremental encoder
 k1 = Hs / incr. encoder + brake
 k2 = Absolute encoder
 k3 = Absolute encoder + brake

Order code:

esiMot x/x.xxx.xxX.XXX — Omitted in standard design

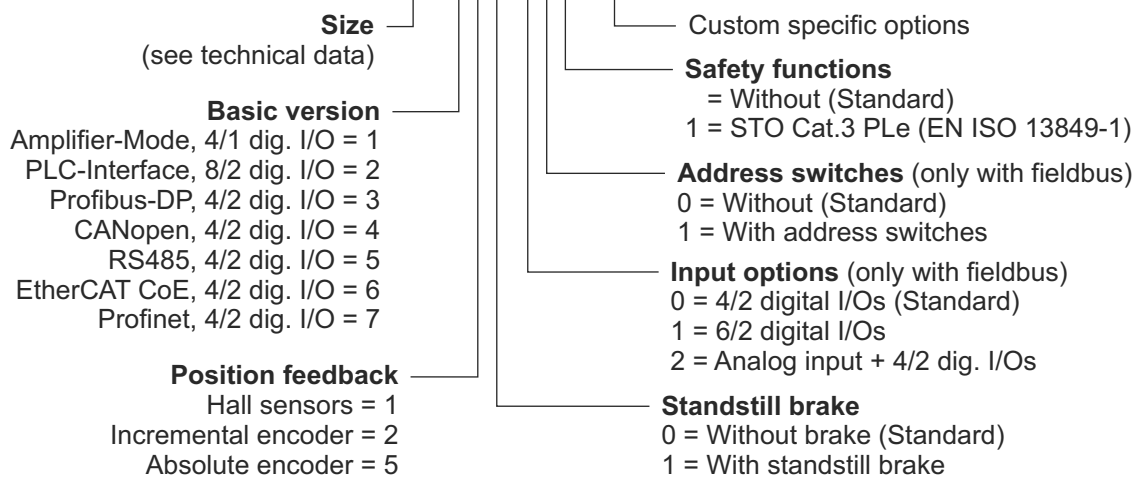

All data in this folder have an informative character without warranty of characteristics. Changes without previous announcement reserved.

esitron-electronic GmbH

Ernst-Zimmermann-Str. 18
 D-88045 Friedrichshafen
 Internet: www.esitron.de

Tel. +49(0)7541-6000-0
 Fax +49(0)7541-6000-11
 E-Mail: info@esitron.de