

RNSA - SELF ADJUSTING SHOCKS
RCOS - CUSTOM ORIFICED SHOCK
RCBS - CRANE BUMPER SHOCK

R-SERIES SHOCK ABSORBERS

- **EFFECTIVE WEIGHT RANGE: 15 - 2,100,000 LBS.**
- **STAINLESS STEEL MODELS AVAILABLE**
- **SOLID ALL WELDED HEAVY DUTY CONSTRUCTION**
- **OPERATING TEMPERATURE RANGE: -10°F TO 150°F**

THE R-SERIES SHOCK ABSORBER IS A RUGGED INDUSTRIAL SHOCK ABSORBER THAT WILL FIT VIRTUALLY EVERY APPLICATION. IT IS AVAILABLE IN CUSTOM ORIFICED, SELF ADJUSTING, AND CRANE BUMPER MODELS WITH A VARIETY OF MOUNTING STYLES AND PISTON ROD RETURN METHODS.

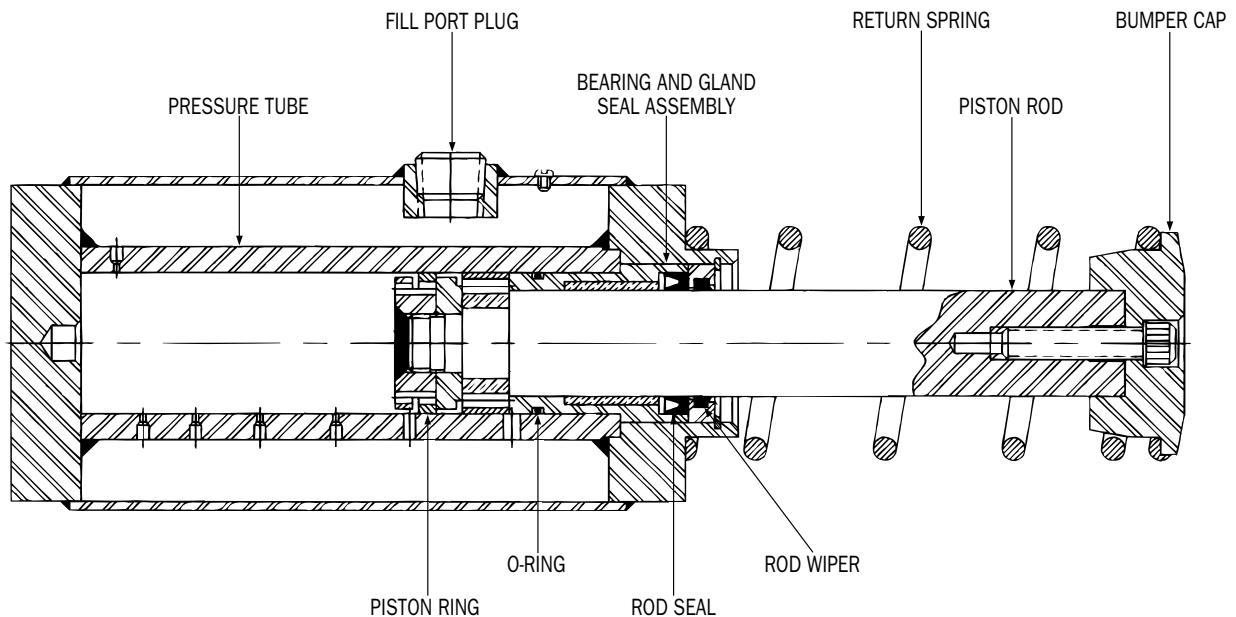

— **ASK ABOUT OUR EXPEDITE SERVICE!** —

www.efdyn.com

- **HIGH TEMPERATURE FLUIDS AVAILABLE ON REQUEST**
- **6" AND 8" BORE SIZES AVAILABLE**
- **USED IN PAPER MILLS, FOUNDRIES, SAW MILLS, OVERHEAD CRANES, STACKER CRANES, MACHINE TOOLS, PACKAGING EQUIPMENT, AUTOMATED ASSEMBLY LINES, STEEL MILLS, AND MATERIAL HANDLING**



HOW TO ORDER R-SERIES SHOCK ABSORBERS

The model designation for R-series shock absorbers is a coded description of the unit defined as shown in this example.

RXXX • 1 1/8 x 2 • BS • RE • 99

RCOS- Custom Orificed RNSA- Self Adjusting RCBS- Crane Bumper	Bore Size	Stroke Length	Mounting Method	Piston Rod Return Method	Selected Metering Designation	Designates Standard Unit Without Modifications
F- Front Square Flange • B- Back Square Flange • BP- Back Primary • *FP-Front Primary • *FBP-Front-Back Primary • L-Lug Mount • BL-Square Back Flange- Front Lug • HC-Rear Hinge-Front Clevis • HR-Rear Hinge-Front Rod Eye • **RB- Rectangular Back Flange • **RF-Rectangular Front Flange				S- Spring Return A- Air (external accumulator required) M- Mechanical C- Air Charged		

* Not available in external spring return models. (except in 4" bore)

** Available in 1 1/2" and 3" bore only

R-SERIES SHOCK ABSORBER

1 1/8" BORE MODEL

1 1/8" R-SERIES

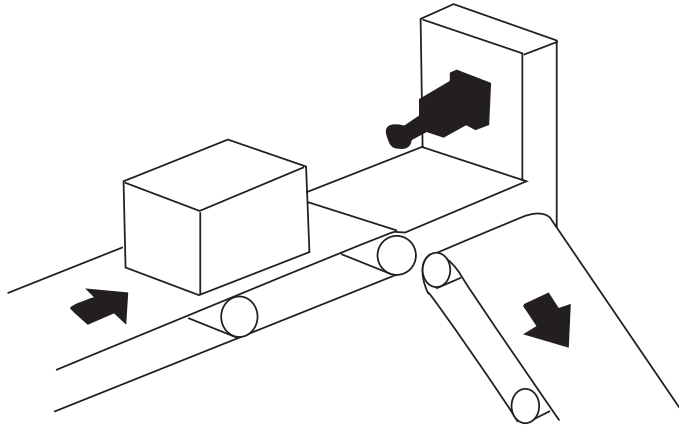

RNSA: SIZE SELECTION TABLE

BORE	STROKE	WE EFFECTIVE WEIGHT (LBS.)			ENERGY PER CYCLE (IN-LBS)	ENERGY PER HOUR (IN-LBS)		(B) WE X V ²	WEIGHT LBS
		LM (LIGHT)	MH (MEDIUM)	HV (HEAVY)		SELF CONTAINED	AIR RETURN		
1 1/8"	2	75 - 2,700	200 - 7,200	1,000 - 36,000	8,000	1,300,000	4,300,000	42,400	12
	4	100 - 3,600	300 - 10,800	2,000 - 72,000	16,000	1,700,000	4,700,000	84,500	14
	6	125 - 4,500	400 - 14,400	3,000 - 108,000	24,000	2,200,000	5,200,000	127,200	17
	8	150 - 5,400	500 - 18,000	4,000 - 144,000	32,000	2,600,000	5,600,000	169,600	20

For standard metered shocks, use $W_e V^2$ to select size from Size Selection Tables.
The maximum velocity allowable for a shock absorber can be determined by using (B) values in the table.

RCOS / RCBS: SIZE SELECTION TABLE

BORE	STROKE	WE EFFECTIVE WEIGHT (LBS)					ENERGY PER CYCLE (IN-LBS)	ENERGY PER HOUR (IN-LBS)		(B) WE X V ²	WEIGHT LBS
		RA	RB	RC	RD	RE		SELF CONTAINED	AIR RETURN		
1 1/8"	2	15 - 90	80 - 450	360 - 2,160	1,770 - 10,600	8,500 - 51,000	11,000	1,300,000	4,300,000	58,000	12
	4	20 - 120	100 - 600	500 - 3,000	2,500 - 15,000	9,000 - 54,000	22,000	1,700,000	4,700,000	116,000	14
	6	25 - 150	130 - 750	630 - 3,750	3,100 - 18,000	10,000 - 60,000	32,000	2,200,000	5,200,000	174,000	17
	8	30 - 180	150 - 870	710 - 4,300	3,500 - 21,000	11,000 - 66,000	43,000	2,600,000	5,600,000	232,000	20
	12	40 - 240	200 - 1,170	960 - 5,700	4,700 - 28,000	12,500 - 75,000	65,000	4,800,000	9,800,000	291,000	24
	18	50 - 300	250 - 1,470	1,200 - 7,200	5,900 - 35,000	15,000 - 90,000	97,000	6,000,000	14,000,000	435,000	28

— ASK ABOUT OUR EXPEDITE SERVICE! —

www.efdyn.com

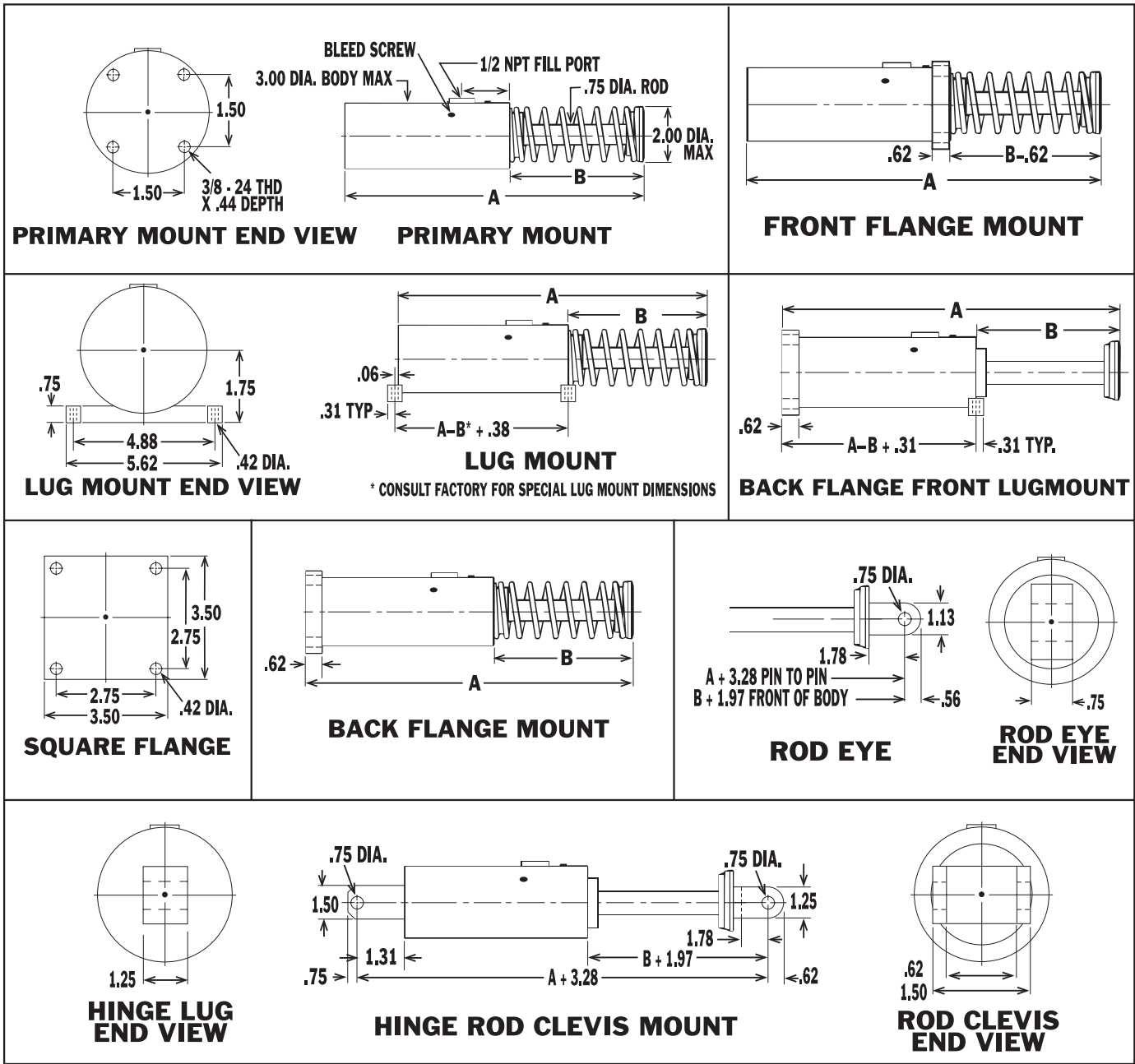

- 12", 18" and 24" stroke models have internal springs.
- Front end primary mount not available on external spring models.
- RCBS models are equipped with a safety chain.
- Add 1 1/2" to A and B for models with chain.

STROKE	DIMENSIONS			
	(S) SPRING RETURN MODELS		(A) AIR RETURN (C) AIR CHARGED RETURN (M) MECHANICAL RETURN MODELS	
	DIM. A	DIM. B	DIM. A	DIM. B
2	8.88	4.00	8.88	4.00
4	12.88	6.00	12.88	6.00
6	17.88	9.00	17.88	9.00
8	22.88	12.00	20.75	10.13
12	36.75	14.13	29.75	14.13
18	53.25	20.13	42.75	20.13
24	72.75	26.13	58.75	26.13

R-SERIES SHOCK ABSORBER

1½" BORE MODEL

1½" R-SERIES

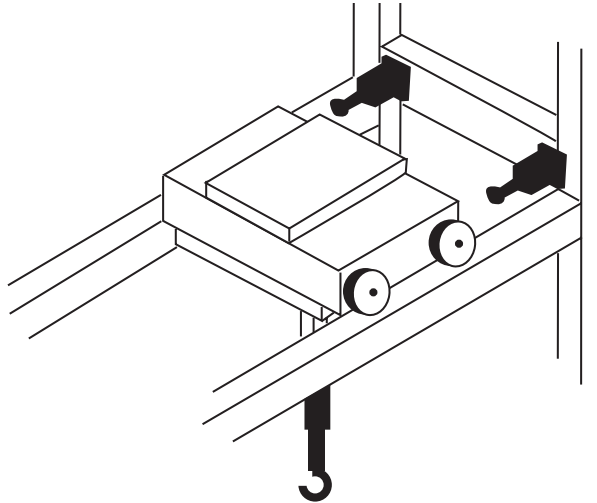

RNSA: SIZE SELECTION TABLE

BORE	STROKE	WE EFFECTIVE WEIGHT IN (LBS.)			ENERGY PER CYCLE (IN-LBS)	ENERGY PER HOUR (IN-LBS)		(B) WE X V ²	WEIGHT LBS
		LM (LIGHT)	MH (MEDIUM)	HV (HEAVY)		SELF CONTAINED	AIR RETURN		
1½"	2	200 – 7,200	1,000 – 36,000	2,000 – 72,000	14,000	1,600,000	4,600,000	75,400	15
	3 1/2	250 – 9,000	1,500 – 54,000	3,000 – 108,000	25,000	1,900,000	4,900,000	131,900	17
	5	300 – 10,800	2,000 – 72,000	4,000 – 144,000	35,000	2,200,000	5,200,000	188,500	21
	6 1/2	350 – 12,600	2,500 – 90,000	5,000 – 180,000	46,000	2,600,000	5,600,000	245,000	24
	8	400 – 14,400	3,000 – 108,000	6,000 – 216,000	56,000	2,900,000	7,900,000	302,000	28
	10	450 – 16,200	3,500 – 126,000	7,000 – 252,000	70,000	3,400,000	8,400,000	377,000	32

For standard metered shocks, use $W_e V^2$ to select size from Size Selection Tables.
The maximum velocity allowable for a shock absorber can be determined by using (B) values in the table.

RCOS / RCBS: SIZE SELECTION TABLE

BORE	STROKE	WE EFFECTIVE WEIGHT (LBS)					ENERGY PER CYCLE (IN-LBS)	ENERGY PER HOUR (IN-LBS)		(B) WE X V ²	WEIGHT LBS
		RA	RB	RC	RD	RE		SELF CONTAINED	AIR RETURN		
1½"	2	30 – 180	140 – 870	710 – 4,200	3,500 – 21,000	12,500 – 75,000	19,000	1,600,000	4,600,000	102,000	15
	3 1/2	40 – 240	200 – 1,170	950 – 5,700	4,700 – 28,000	13,500 – 81,000	34,000	1,900,000	4,900,000	181,000	17
	5	50 – 300	240 – 1,470	1,200 – 7,000	6,000 – 35,000	14,500 – 87,000	48,000	2,200,000	5,200,000	258,000	21
	6 1/2	60 – 360	300 – 1,770	1,400 – 9,000	7,000 – 42,000	15,500 – 93,000	62,000	2,600,000	5,600,000	336,000	24
	8	70 – 420	340 – 2,070	1,700 – 10,000	8,000 – 50,000	16,500 – 99,000	77,000	2,900,000	7,900,000	414,000	28
	10	80 – 480	400 – 2,370	1,900 – 12,000	9,000 – 57,000	18,000 – 108,000	96,000	3,400,000	8,400,000	517,000	32
	12	90 – 540	440 – 2,670	2,200 – 13,000	11,000 – 64,000	19,500 – 117,000	115,000	5,800,000	14,000,000	621,000	36
	18	100 – 600	500 – 2,970	2,400 – 15,000	12,000 – 71,000	23,500 – 141,000	173,000	8,700,000	17,000,000	931,000	50
	24	110 – 660	540 – 3,270	2,700 – 16,000	13,000 – 78,000	27,000 – 162,000	234,000	11,000,000	22,000,000	1,242,000	74

— ASK ABOUT OUR EXPEDITE SERVICE! —

www.efdyn.com

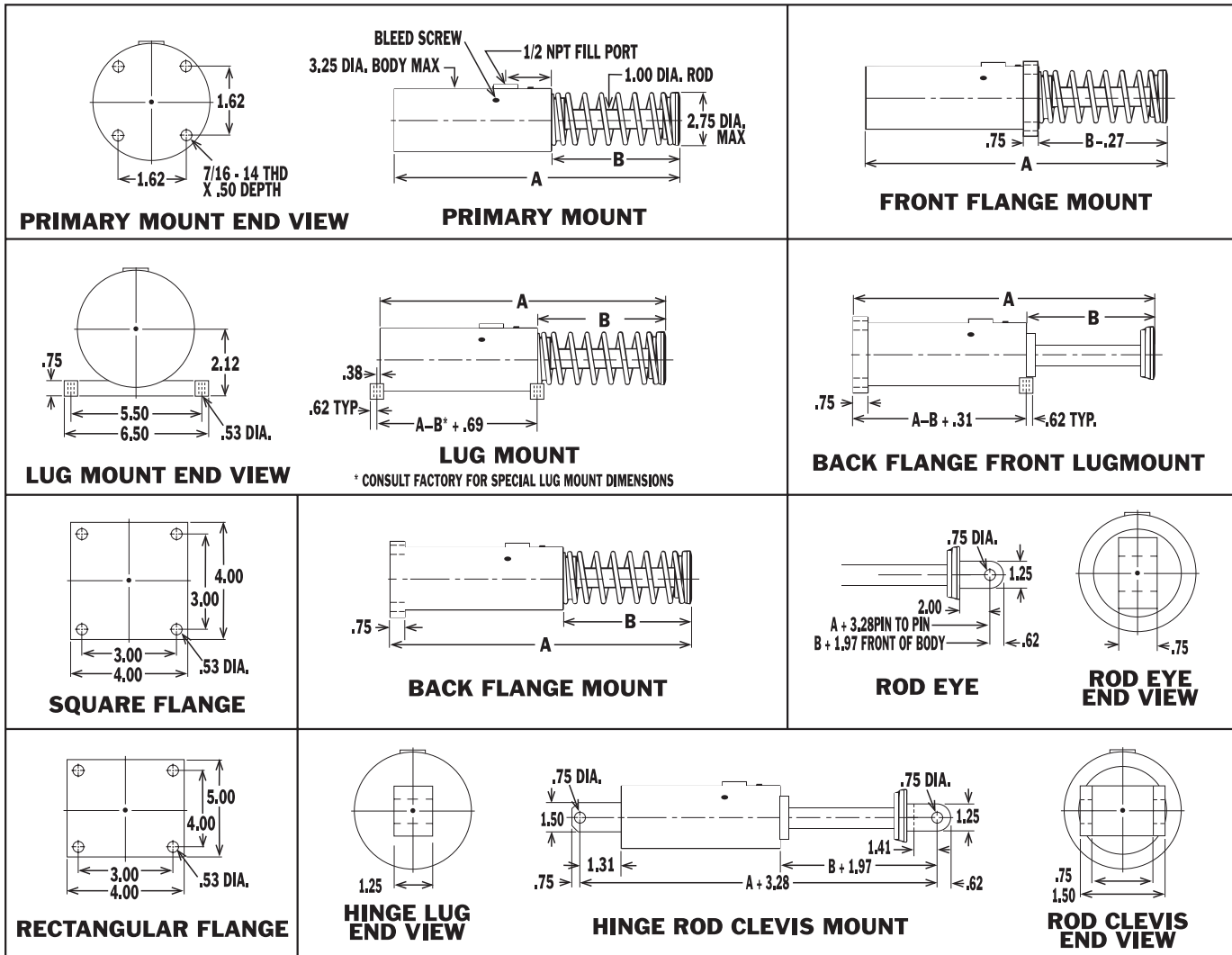

- 12", 18", 24" and 36" stroke models have internal springs.
- Front end primary mount not available on external spring models.
- RCBS models are equipped with a safety chain.
- Add 1 1/2" to A and B for models with chain.

STROKE	DIMENSIONS			
	(S) SPRING RETURN MODELS		(A) AIR RETURN (C) AIR CHARGED RETURN (M) MECHANICAL RETURN MODELS	
	DIM. A	DIM. B	DIM. A	DIM. B
2	9.69	4.40	9.69	4.40
3 1/2	12.69	5.90	12.69	5.90
5	15.69	7.40	15.69	7.40
6 1/2	20.96	11.15	19.44	9.65
8	23.96	12.65	21.50	10.19
10	27.96	14.65	25.50	12.19
12	38.25	14.19	30.00	14.19
18	57.25	20.19	44.00	20.19
24	73.50	26.19	57.00	26.19
36	112.25	38.19	84.00	38.19

R-SERIES SHOCK ABSORBER

2" BORE MODEL

2" R-SERIES

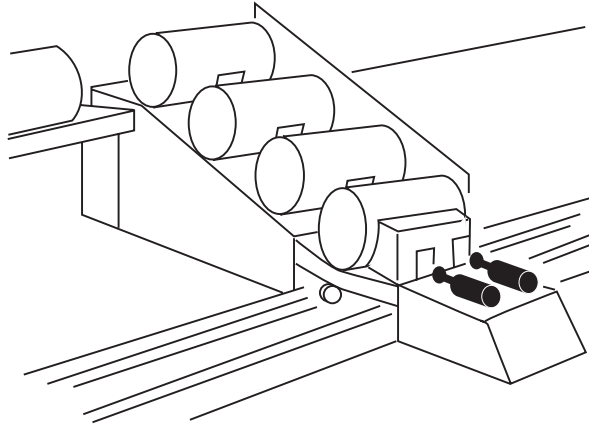

RNSA: SIZE SELECTION TABLE

BORE	STROKE	WE EFFECTIVE WEIGHT (LBS)			ENERGY PER CYCLE (IN-LBS)	ENERGY PER HOUR (IN-LBS)		(B) WE X V ²	WEIGHT LBS
		LM (LIGHT)	MH (MEDIUM)	HV (HEAVY)		SELF CONTAINED	AIR RETURN		
2	2	500 – 18,000	2,000 – 72,000	3,000 – 108,000	25,000	3,300,000	8,300,000	132,000	35
	4	750 – 27,000	2,500 – 90,000	5,000 – 180,000	49,000	3,900,000	8,900,000	264,000	41
	6	1,000 – 36,000	3,000 – 108,000	7,000 – 252,000	74,000	4,600,000	9,600,000	396,000	48
	8	1,250 – 45,000	3,500 – 126,000	9,000 – 324,000	99,000	5,200,000	13,000,000	528,000	55
	10	1,500 – 54,000	4,000 – 144,000	11,000 – 396,000	123,000	5,900,000	14,000,000	660,000	61
	12	1,750 – 63,000	4,500 – 180,000	13,000 – 468,000	148,000	6,500,000	15,000,000	792,000	67

For standard metered shocks, use $W_e V^2$ to select size from Size Selection Tables.
The maximum velocity allowable for a shock absorber can be determined by using (B) values in the table.

RCOS / RCBS: SIZE SELECTION TABLE

BORE	STROKE	WE EFFECTIVE WEIGHT (LBS)					ENERGY PER CYCLE (IN-LBS)	ENERGY PER HOUR (IN-LBS)		(B) WE X V ²	WEIGHT LBS
		RA	RB	RC	RD	RE		SELF CONTAINED	AIR RETURN		
2	2	30 – 180	140 – 870	710 – 4,200	3,500 – 21,000	16,000 – 96,000	34,000	3,300,000	8,300,000	180,000	35
	4	40 – 240	200 – 1,170	950 – 5,700	4,700 – 28,000	18,000 – 108,000	67,000	3,900,000	8,900,000	360,000	41
	6	50 – 300	240 – 1,470	1,200 – 7,000	6,000 – 35,000	20,000 – 120,000	101,000	4,600,000	9,600,000	540,000	48
	8	60 – 360	300 – 1,770	1,400 – 9,000	7,000 – 42,000	22,000 – 132,000	134,000	5,200,000	13,000,000	720,000	55
	10	70 – 420	340 – 2,070	1,700 – 10,000	8,000 – 50,000	24,000 – 144,000	168,000	5,900,000	14,000,000	906,000	61
	12	80 – 480	400 – 2,370	1,900 – 12,000	9,000 – 57,000	26,000 – 156,000	202,000	6,500,000	15,000,000	1,080,000	67
	18	90 – 540	440 – 2,670	2,200 – 13,000	11,000 – 64,000	36,000 – 216,000	302,000	13,000,000	24,000,000	1,620,000	86
	24	100 – 600	500 – 2,970	2,400 – 15,000	12,000 – 71,000	48,000 – 288,000	403,000	16,000,000	32,000,000	2,160,000	105
	36	110 – 660	540 – 3,270	2,700 – 16,000	13,000 – 78,000	60,000 – 360,000	504,000	24,000,000	48,000,000	3,240,000	142

— ASK ABOUT OUR EXPEDITE SERVICE! —

www.efdyn.com

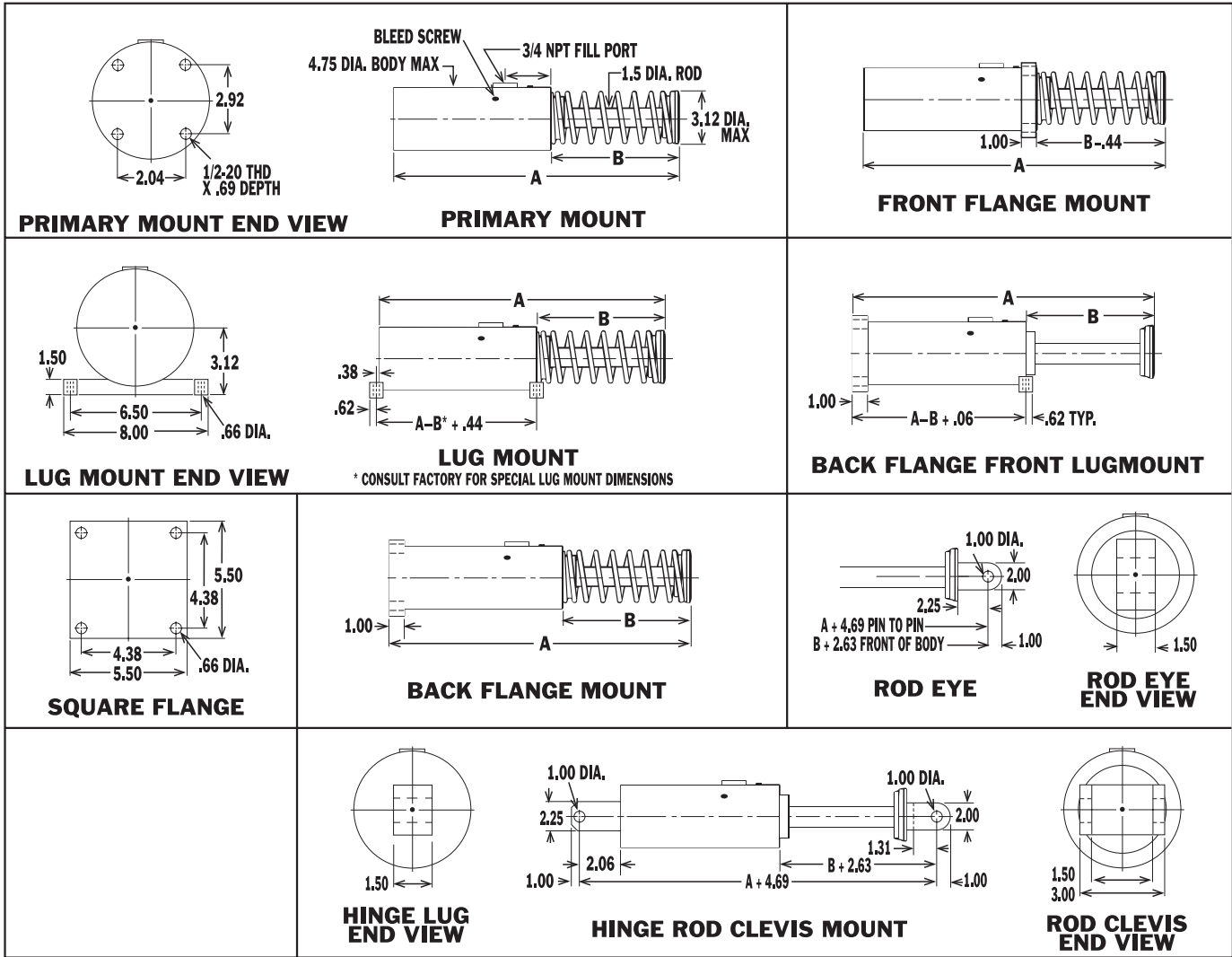

- 18", 24", 30", 36", 42" and 48" stroke models have internal springs.
- Front end primary mount not available on external spring models.
- RCBS models are equipped with a safety chain.
- Add 1½" to A and B for models with chain.

DIMENSIONS				
STROKE	(S) SPRING RETURN MODELS		(A) AIR RETURN (C) AIR CHARGED RETURN (M) MECHANICAL RETURN MODELS	
	DIM. A	DIM. B	DIM. A	DIM. B
2	12.31	4.75	12.31	4.75
4	16.31	6.75	16.31	6.75
6	20.31	8.75	20.31	8.75
8	25.81	12.25	24.31	10.75
10	29.81	14.25	28.31	12.75
12	34.31	16.75	31.81	14.25
18	56.81	20.25	45.31	20.25
24	73.81	26.25	58.31	26.25
30	90.81	32.25	71.31	32.25
36	107.81	38.25	84.31	38.25
42	127.81	44.25	100.31	44.25
48	143.81	50.25	112.81	50.25

R-SERIES SHOCK ABSORBER

3" BORE MODEL

3" R-SERIES

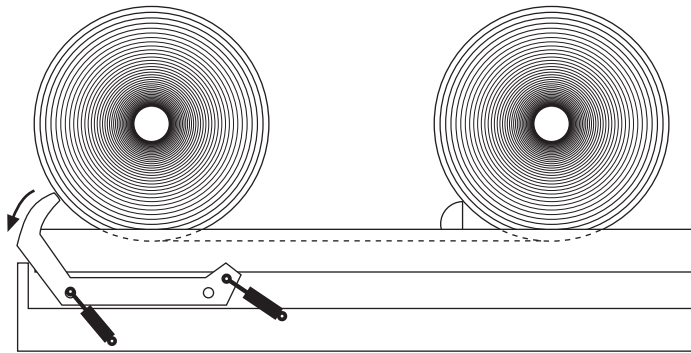

RNSA: SIZE SELECTION TABLE

BORE	STROKE	WE EFFECTIVE WEIGHT (IN-LBS)			ENERGY PER CYCLE (IN-LBS)	ENERGY PER HOUR (IN-LBS)		(B) WE X V ²	WEIGHT LBS
		LM (LIGHT)	MH (MEDIUM)	HV (HEAVY)		SELF CONTAINED	AIR RETURN		
3	4	750 – 27,000	2,500 – 90,000	10,000 – 360,000	106,000	5,000,000	10,000,000	565,000	55
	5	1,000 – 36,000	3,000 – 108,000	12,000 – 432,000	132,000	5,400,000	10,400,000	707,000	63
	8	1,250 – 45,000	3,500 – 126,000	14,000 – 504,000	211,000	6,600,000	14,000,000	1,131,000	81
	12	1,500 – 54,000	4,000 – 144,000	16,000 – 576,000	317,000	8,200,000	16,000,000	1,696,000	110
	16	1,750 – 63,000	4,500 – 180,000	18,000 – 648,000	422,000	9,800,000	20,000,000	2,262,000	148

For standard metered shocks, use $W_e V^2$ to select size from Size Selection Tables.
The maximum velocity allowable for a shock absorber can be determined by using (B) values in the table.

RCOS / RCBS: SIZE SELECTION TABLE

BORE	STROKE	WE EFFECTIVE WEIGHT (LBS)					ENERGY PER CYCLE (IN-LBS)	ENERGY PER HOUR (IN-LBS)		(B) WE X V ²	WEIGHT LBS
		RA	RB	RC	RD	RE		SELF CONTAINED	AIR RETURN		
3	4	100 – 600	500 – 2,900	2,400 – 14,400	11,800 – 71,000	36,000 – 216,000	144,000	5,000,000	10,000,000	750,000	55
	5	150 – 900	730 – 4,400	3,600 – 21,600	17,600 – 106,000	51,000 – 306,000	180,000	5,400,000	10,400,000	960,000	63
	8	200 – 1,200	1,000 – 5,900	4,800 – 28,800	23,500 – 141,000	66,000 – 396,000	288,000	6,600,000	14,000,000	1,500,000	81
	12	250 – 1,500	1,200 – 7,400	6,000 – 36,000	29,400 – 176,000	81,000 – 486,000	432,000	8,200,000	16,000,000	2,250,000	110
	16	300 – 1,800	1,500 – 8,800	7,200 – 43,200	35,000 – 212,000	96,000 – 576,000	576,000	9,800,000	20,000,000	3,000,000	148
	24	350 – 2,100	1,700 – 10,300	8,400 – 50,400	41,000 – 247,000	111,000 – 666,000	864,000	19,000,000	35,000,000	4,500,000	220
	36	400 – 2,400	2,000 – 11,800	9,600 – 57,600	47,000 – 282,000	126,000 – 756,000	1,296,000	27,000,000	51,000,000	6,750,000	387
	48	450 – 2,700	2,200 – 13,200	10,800 – 64,800	53,000 – 316,000	141,000 – 846,000	1,728,000	35,000,000	65,000,000	9,000,000	520

— ASK ABOUT OUR EXPEDITE SERVICE! —

www.efdyn.com

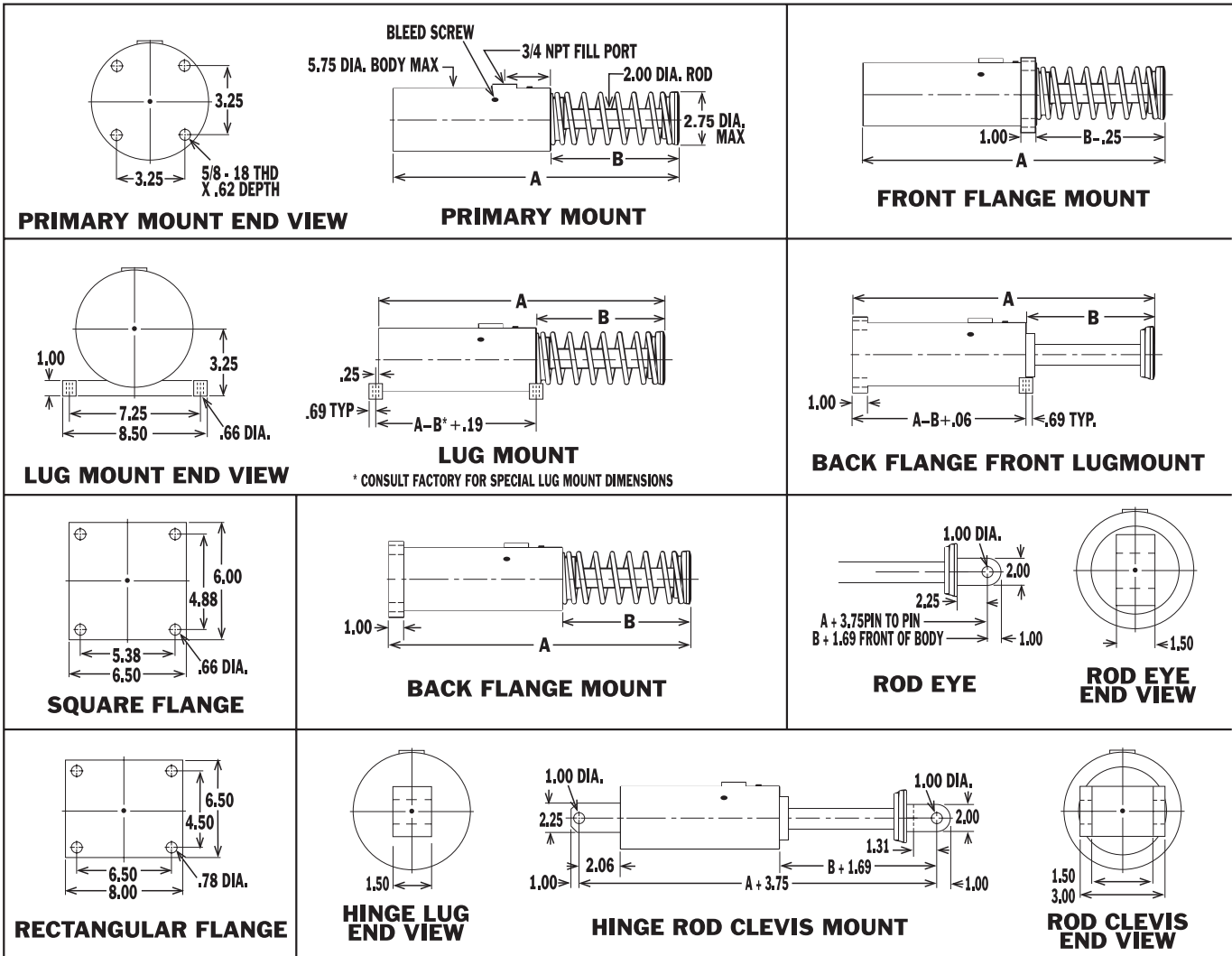

- 24", 36", 48" and 60" stroke models have internal springs.
- Front end primary mount not available on external spring models.
- RCBS models are equipped with a safety chain.
- Add 1½" to A and B for models with chain.

STROKE	DIMENSIONS			
	(S) SPRING RETURN MODELS		(A) AIR RETURN (C) AIR CHARGED RETURN (M) MECHANICAL RETURN MODELS	
	DIM. A	DIM. B	DIM. A	DIM. B
4	17.25	7.50	17.25	7.50
5	19.25	8.50	19.25	8.50
8	27.44	13.69	25.25	11.50
12	37.44	19.69	35.03	17.28
16	49.75	26.00	43.44	19.69
24	70.94	26.88	59.94	26.88
36	103.94	38.88	85.94	38.88
48	136.94	50.88	111.94	50.88
60	169.94	62.88	137.94	62.88

R-SERIES SHOCK ABSORBER

4" BORE MODEL

4" R-SERIES

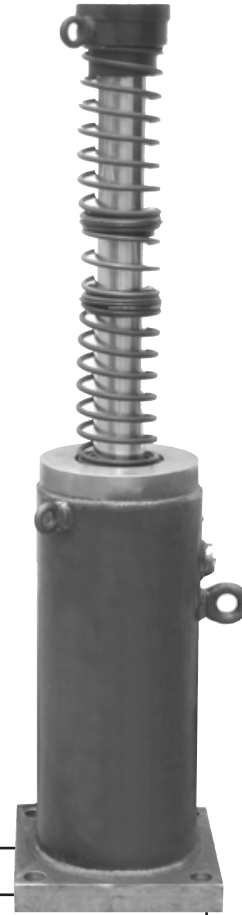
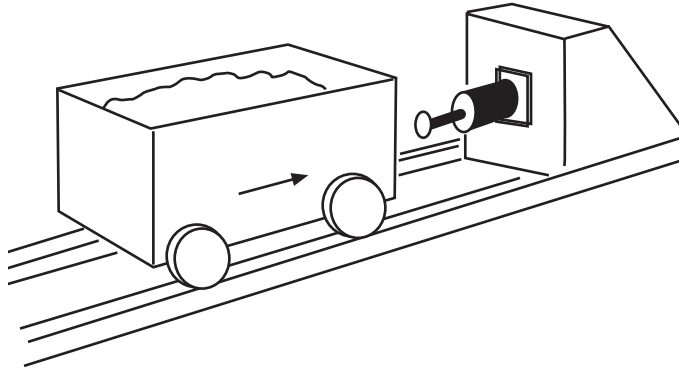

RNSA: SIZE SELECTION TABLE

BORE	STROKE	WE EFFECTIVE WEIGHT (LBS)			ENERGY PER CYCLE (IN-LBS)	ENERGY PER HOUR (IN-LBS)		(B) WE X V ²	WEIGHT LBS
		LM (LIGHT)	MH (MEDIUM)	HV (HEAVY)		SELF CONTAINED	AIR RETURN		
4	4	1,500 – 54,000	4,000 – 144,000	15,000 – 540,000	199,000	9,500,000	20,000,000	1,065,000	180
	6	2,000 – 72,000	5,000 – 180,000	20,000 – 720,000	298,000	11,000,000	22,000,000	1,597,000	215
	8	2,500 – 90,000	6,000 – 216,000	25,000 – 900,000	398,000	12,000,000	23,000,000	2,130,000	245
	10	3,000 – 108,000	7,000 – 252,000	30,000 – 1,080,000	498,000	13,000,000	24,000,000	2,662,000	276
	12	3,500 – 126,000	8,000 – 288,000	35,000 – 1,260,000	597,000	14,000,000	30,000,000	3,194,000	306
	16	4,000 – 144,000	9,000 – 324,000	40,000 – 1,440,000	796,000	16,000,000	32,000,000	4,259,000	367

For standard metered shocks, use $W_E V^2$ to select size from Size Selection Tables.
The maximum velocity allowable for a shock absorber can be determined by using (B) values in the table.

RCOS / RCBS: SIZE SELECTION TABLE

BORE	STROKE	WE EFFECTIVE WEIGHT (LBS)					ENERGY PER CYCLE (IN-LBS)	ENERGY PER HOUR (IN-LBS)		(B) WE X V ²	WEIGHT LBS
		RA	RB	RC	RD	RE		SELF CONTAINED	AIR RETURN		
4	4	100 – 600	500 – 2,900	2,400 – 14,000	12,000 – 71,000	50,000 – 300,000	271,000	9,500,000	20,000,000	1,456,000	180
	6	150 – 900	700 – 4,400	3,600 – 22,000	18,000 – 106,000	70,000 – 420,000	407,000	11,000,000	22,000,000	2,184,000	215
	8	200 – 1,200	1,000 – 5,900	4,800 – 29,000	24,000 – 141,000	90,000 – 540,000	542,000	12,000,000	23,000,000	2,912,000	245
	10	250 – 1,500	1,200 – 7,400	6,000 – 36,000	29,000 – 176,000	110,000 – 660,000	678,000	13,000,000	24,000,000	3,640,000	276
	12	300 – 1,800	1,500 – 8,800	7,000 – 43,000	35,000 – 212,000	130,000 – 780,000	814,000	14,000,000	30,000,000	4,368,000	306
	16	350 – 2,100	1,700 – 10,300	8,000 – 50,000	41,000 – 247,000	150,000 – 900,000	1,085,000	16,000,000	32,000,000	5,824,000	367
	24	400 – 2,400	2,000 – 11,800	10,000 – 58,000	47,000 – 282,000	200,000 – 1,200,000	1,356,000	28,000,000	52,000,000	8,736,000	490
	36	450 – 2,700	2,200 – 13,200	11,000 – 65,000	53,000 – 317,000	250,000 – 1,500,000	2,034,000	40,000,000	70,000,000	13,104,000	675
	48	500 – 3,000	2,500 – 14,700	12,000 – 72,000	59,000 – 353,000	300,000 – 1,800,000	2,712,000	51,000,000	87,000,000	17,472,000	900
	60	550 – 3,300	2,700 – 16,200	13,000 – 79,000	65,000 – 388,000	350,000 – 2,100,000	3,390,000	62,000,000	98,000,000	21,840,000	1125

— ASK ABOUT OUR EXPEDITE SERVICE! —

www.efdyn.com

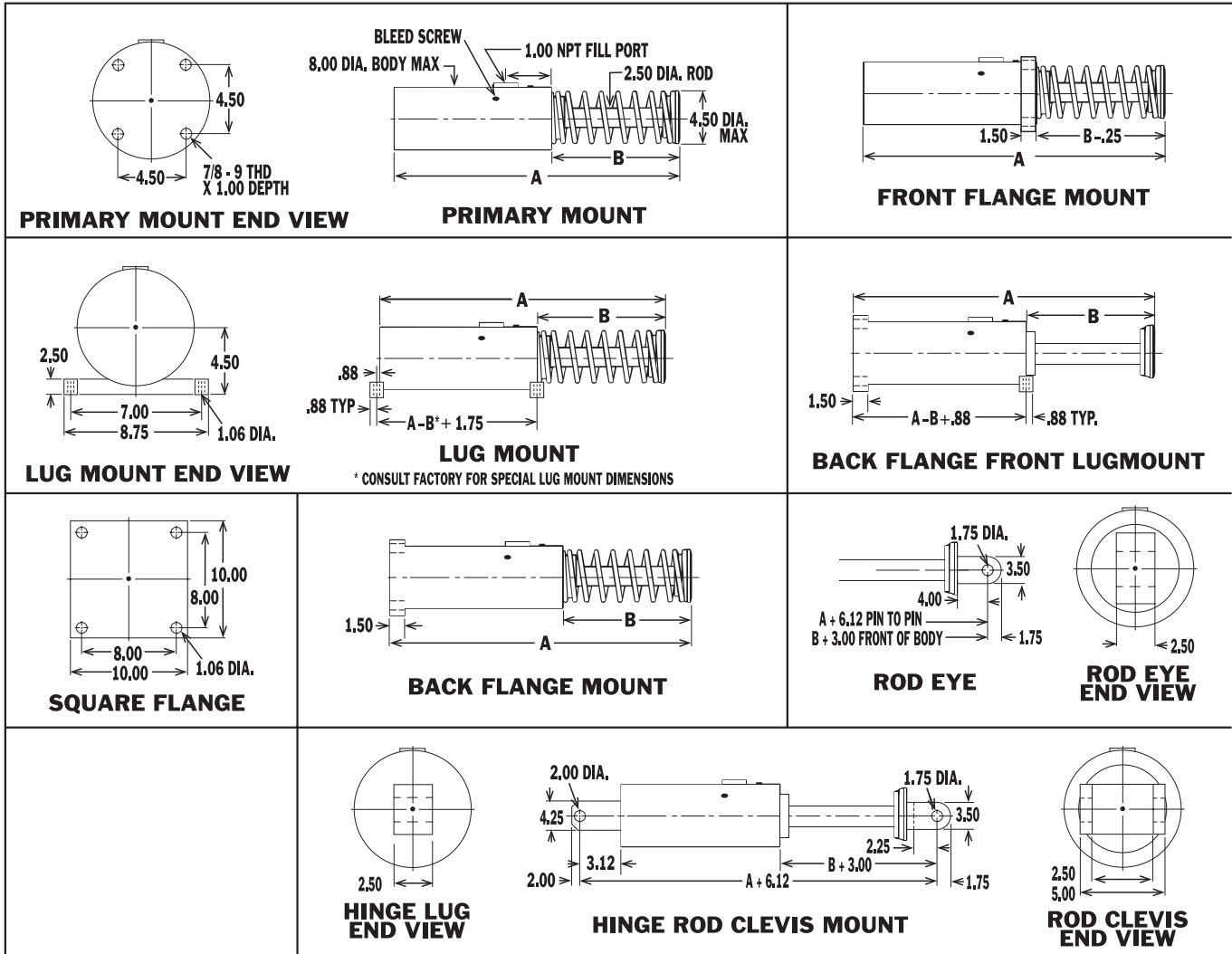

- 24", 36", 48", 60" and 72" stroke models have internal springs.
- Front end primary mount not available on external spring models.
- RCBS models are equipped with a safety chain.
- Add 1½" to A and B for models with chain.

DIMENSIONS				
STROKE	(S) SPRING RETURN MODELS		(A) AIR RETURN (C) AIR CHARGED RETURN (M) MECHANICAL RETURN MODELS	
	DIM. A	DIM. B	DIM. A	DIM. B
4	20.25	7.00	20.25	7.00
6	25.50	10.25	23.50	8.25
8	30.50	13.25	27.50	10.25
10	35.75	16.50	31.50	12.25
12	41.00	19.75	35.50	14.25
16	51.25	26.00	43.50	18.25
24	74.00	26.25	61.25	26.25
36	106.25	38.25	86.25	38.25
48	138.25	50.25	111.25	50.25
60	170.25	62.25	136.25	62.25
72	209.25	74.25	170.25	74.25