



Carling Technologies®
Innovative Designs. Powerful Solutions.

RENEWABLE ENERGY

Circuit Breakers & Disconnects



CATALOG

FOUNDED IN 1920

Since its founding, Carling Technologies has continually forged a tradition of leadership in quality and product innovation.

There are few products that Carling Technologies hasn't turned "ON" and fewer industries that haven't turned to Carling for solutions. With ISO and TS registered manufacturing facilities and technical sales offices worldwide, Carling ranks among the world's largest manufacturers of circuit breakers, switches, power distribution units, digital switching systems and electronic controls.



SWITCHES & CONTROLS

- Rocker
- Toggle
- Pushbutton
- Rotary

CIRCUIT PROTECTION

- Hydraulic-Magnetic
- Thermal
- GFCI / ELCI

CUSTOM SOLUTIONS

- PDU's
- Keypads
- Control Modules

MULTIPLEXED POWER SYSTEMS

- HMI Devices & I/O Modules
- Programmable Displays
- Data Communication Interfaces
- Electrical Systems Monitoring

STRATEGIC MARKETS SERVED:



On/Off Highway



Marine



Telecom/Datacom



Military



Renewable Energy

GLOBAL LOCATIONS:

Carling Technologies
World Headquarters
Plainville, CT, USA
ISO9001:2008
ISO/TS16949:2009

Maretron
Phoenix, AZ, USA

Carling Technologies
Brownsville, TX, USA
ISO14001:2004
ISO9001:2008
ISO/TS16949:2009

Carling Technologies
Matehuala, Mexico
ISO14001:2004
ISO9001:2008
ISO/TS16949:2009

Carling Technologies
Jupiter, FL, USA

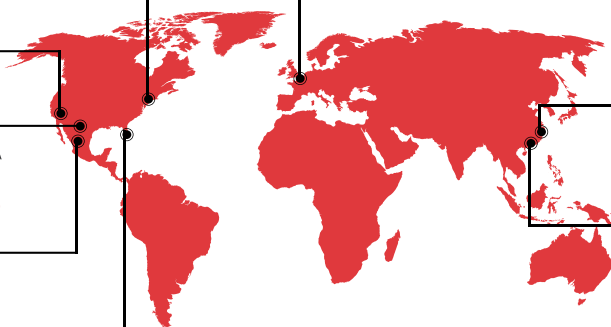

Carling Technologies
European Headquarters
Exeter, UK
ISO9001:2008
ISO/TS16949:2009

Carling Technologies
Kowloon, Hong Kong
ISO9001:2008
ISO/TS16949:2009

Carling Technologies
Zhongshan, China
ISO14001:2004
ISO9001:2008
ISO/TS16949:2009

OTHER SERVED INDUSTRIES:



Medical



Industrial Control



Audio / Visual



Commercial Food



HVAC



Floor Care



Generators



Small Appliances



Security Systems



Test & Measurement

WORLDWIDE NUMBERS:



2000+
EMPLOYEES



150+
ENGINEERS

COMPETITIVE ADVANTAGES⁺

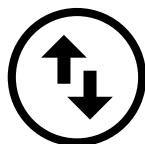

Vertical
Integration



Reliable &
On-Time Delivery



Excellent
Customer Service



Innovative &
Eco-Friendly Products



70+
DISTRIBUTORS



50+
REP FIRMS

Renewable Energy

Circuit Breakers & Disconnects

When you integrate Carling Technologies circuit protection products into your renewable energy generating systems, you are guaranteed maximum protection against harmful overcurrent. Our product line is guaranteed to not only protect the power system itself, but it also safeguards the structure where these systems are installed by eliminating the fire hazard that can be caused by overcurrent.

Table of Contents

	page
Product Selector Guide.....	2
CX-Series.....	3
C-Series.....	13
E-Series.....	34
F-Series.....	43
Time Delay Values.....	53





Within This Catalog, you will find comprehensive product information for each product series including applications, specifications and ordering schemes.

Available Online are tools such as part configurator, product selectors and stock checks. For the latest information on all our products, please visit www.carlingtech.com

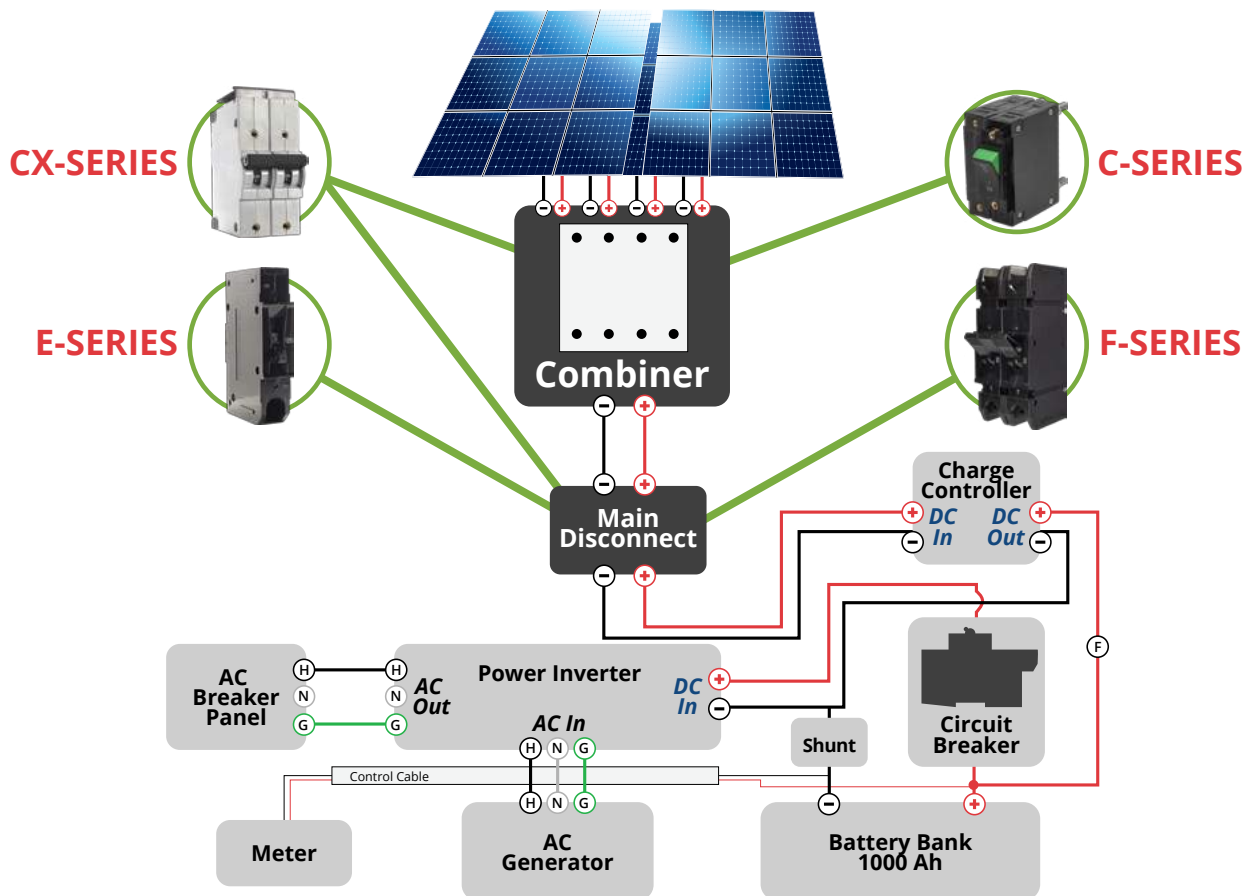
Application Solution Engineers are readily available to assist you in selecting the appropriate product for your application. For further assistance, please email us at custservice@carlingtech.com

Typical Photovoltaic System



	CIRCUIT PROTECTION			
	 CX-Series	 C-Series	 E-Series	 F-Series
Number of Poles	1-5	1-6 (handle) 1-3 (rocker & metal toggle)	1-6	1-3
Actuator Style	handle, 1 per pole	sealed metal toggle handle rocker	handle	handle
Available Delays	DC: instant, ultrashort, short, medium & long	AC, DC, AC/DC: instant, ultrashort, short, medium & long AC, DC: high inrush-short, medium & long	AC, DC, AC/DC: instant, short, medium & long AC, DC, AC/DC: high inrush-short, medium & long	AC, DC: short, medium & long
Max Current & Voltage Ratings	UL Recognized 0.2-115A@600VDC UL Listed 0.2-15A@250/500VDC 0.2-50A@205/410VDC	UL Listed: 0.02-250A@80VDC 0.1-100A@125VDC 0.02-70A@120VAC 0.02-20A@240VAC UL Recognized: 0.02-30A@480WYE/277VAC 2 Pole, 1Ø; 3 Pole, 3Ø 0.02-50A@277VAC 0.02-100A@250VAC, 80VDC 0.02-100A@120V/ 240VAC, 65VDC	UL Listed 0.02-100A@240VAC, 80VDC, 125VDC UL Recognized 0.02-100A@277VAC, 160VDC, 1 pole 0.02-100A@600VAC, 2 Pole 1Ø, 3 pole 3Ø 0.02-120A@125VDC, 1 pole	UL489 Listed: 50-250A@125VDC 100-250A@120/240VAC 100-250A@277VAC 100-250A@208Y/120, 3ØVAC UL489A Listed 250-700A@125VDC
Max Interrupting Capacity	UL Listed and UL Recognized up to 10,000 amps	UL Listed: 50000A@80VDC, 1P only 10000A@120VAC 5000A@125VDC/240VAC UL Recognized: 7500A@80VDC 3000A@125/250VAC, UL only 5000A@250VAC listed construction 5000A@480WYE/277VAC with fuse backup	UL Listed 50000A@80VDC 10000A@125VDC & 240VAC-5KA UL Recognized 5000A@125VDC 5000A@600VAC, without fuse backup 10000A@600VAC, with fuse backup	50000A@125VDC 10000A@120/240, 277, 208Y/120VAC
Auxiliary Switch Rating	20A@80VDC (GO circuit)	10.1A@250VAC 0.1A@125VAC (gold contacts) 0.5A@80VDC	10.1A@250VAC 1.0A@65VDC 0.1A@80VDC	10.1A@250VAC 0.5A@65VDC 0.1A@80VDC
Available Circuits	series trip	series, shunt, relay, switch only, series with remote shutdown, relay & shunt trip dual coil, mid-trip with alarm switch	series, shunt, relay, switch only, series with remote shutdown	series & switch only with or without metering shunt
Terminal Options	10-32 or M5 screw terminals 1/4-20 or M6 threaded stud	10-32 stud, 1/4-20 stud, 10-32 screw with saddle clamp, 7/16 clip & push-in	10-32 stud, 1/4-20 stud, 0-32 screw, 1/4-20 screw, box wire connector	3/8-16 stud, 3/8-16 screw & box wire connector
Mounting Method	threaded insert: #6-32 UNC-2B, or M3X0.5-6H B ISO (2 per pole)	threaded inserts	rear or front panel	rear or front panel
Agency Approvals	UL489, UL1077, TUV (EN60934-2)	UL, CSA, VDE, TUV, UL1500, UL489, UL489A	UL, CSA, VDE, UL1500, UL489	cUL, TUV, UL489, UL489A

*Options and approvals shown may apply to specific construction combinations only, consult factory for clarification.
 Manufacturer reserves the right to change product specifications without prior notice.

CX-Series

CIRCUIT BREAKER

The CX-Series circuit breaker features a unique and innovative arc-quenching configuration that allows the breaker to safely handle high amperage and high DC voltage applications in a compact package. By using a patent pending magnetic flux boosting terminal configuration, a strong magnetic field is created thus motivating the arc into an enhanced arc chamber improving the breaker's overall performance and reliability. The permanent magnets located at the entrance of the arc chamber combined with the upper and lower arc runner increase the magnetic blow out force and aid in motivating the arc off of the contacts and into the arc chamber. An enhanced arc chamber features arc splitter retainers with integrated pressurizing walls, which facilitates heat transfer from the arc thereby providing additional cooling and quick transition into the magnetically induced splitter plates. In turn, the twelve (12) splitter plates attract, segment and cool the arc for full extinction. Combined, these innovative features make the CX-Series breaker the best in class, providing stable performance even in the most demanding applications.



Resources:

[Download 3D CAD Files](#)

[IGS >](#)

[STP >](#)

[Watch Product Video](#)



Product Highlights:

- ◆ UL 489 & UL 489B Listed
- ◆ TUV Certified IEC/EN 60947-2
- ◆ Temperature stable hydraulic-magnetic overcurrent sensing technology
- ◆ Optional relay trip circuit permitting remote operator system shut down
- ◆ Perfect fit for 380VDC Applications

CX-Series DESIGN FEATURES

HYDRAULIC/MAGNETIC SENSING COIL

UPPER ARC RUNNER

Aids in motivating arc off of movable contact and into arc chamber

MAGNETS

ARC SPLITTER RETAINER

with integrated pressurizing walls

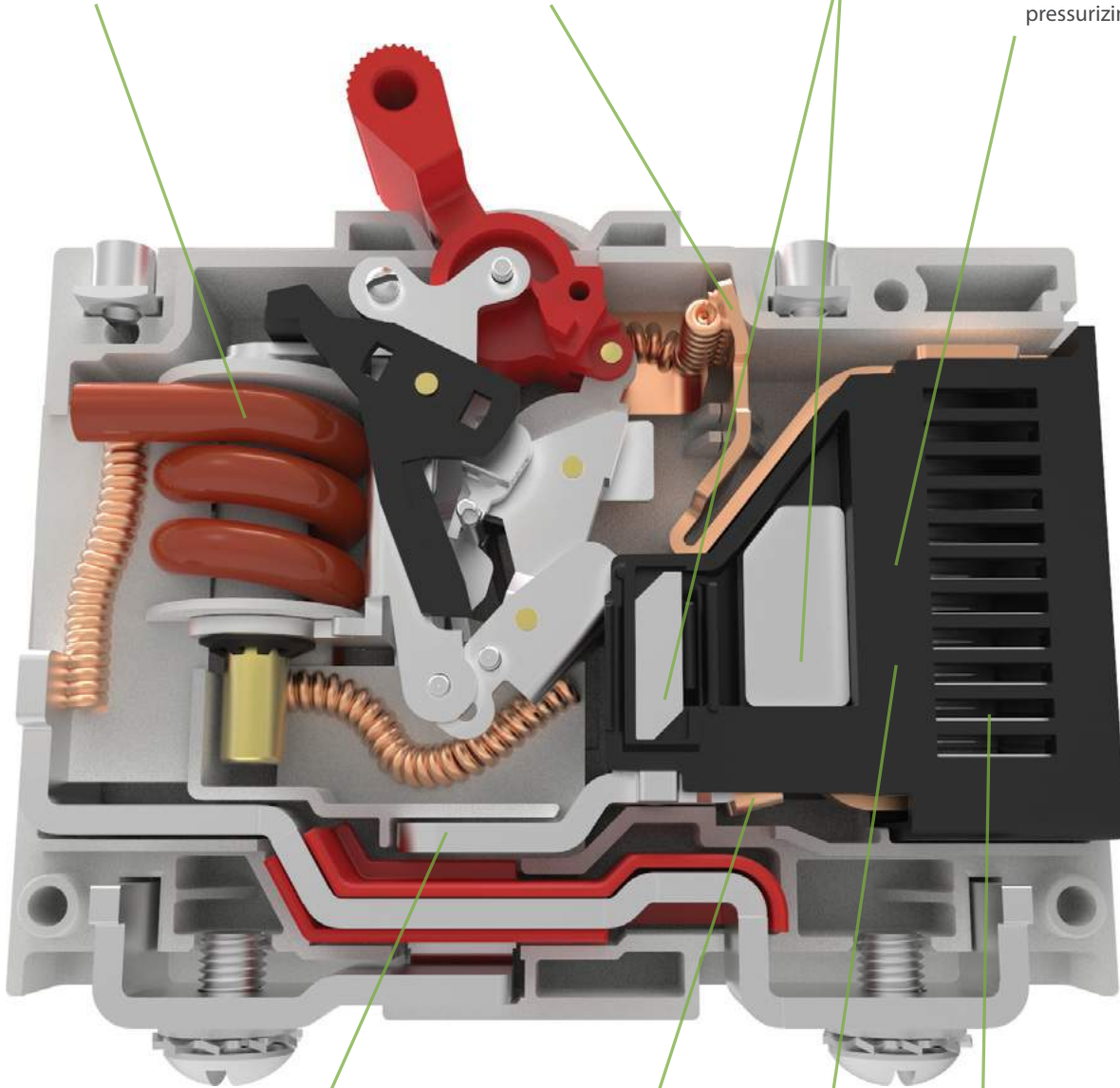

PATENT PENDING MAGNETIC FLUX BOOSTING TERMINAL CONFIGURATION

Design enhances motivation of arc into arc chamber

LOWER ARC RUNNER

Aids in motivating arc off of stationary contact and into arc chamber

LARGE ARC GAP

To generate high arc voltages

(12) ARC DEIONIZING SPLITTER PLATES

Electrical Tables

Table A: Lists UL Listed (UL489) configuration and performance capabilities as a Molded Case Circuit Breaker

CX SERIES TABLE A : UL489 LISTED BRANCH CIRCUIT BREAKERS					
CIRCUIT CONFIGURATION	VOLTAGE		MAX CURRENT RATING AMPS	INTERRUPTING CAPACITY (AMPS)	NUMBER OF POLES
	MAX. RATING	FREQUENCY			
SERIES	250	D.C.	15	5,000	1
	250 / 500	D.C.	15	10,000	2
	410 / 205	D.C.	50	10,000	2

Table B: Lists UL Recognized configurations and performance capabilities as a Component Supplementary Protector

CX SERIES TABLE B : UL1077 COMPONENT SUPPLEMENTARY PROTECTOR						
CIRCUIT CONFIGURATION	VOLTAGE		MAX CURRENT RATING AMPS	INTERRUPTING CAPACITY (AMPS)	NUMBER OF POLES	APPLICATION CODE
	MAX. RATING	FREQUENCY				
SERIES	300	D.C.	1 - 75	5,000	1	TC1, OL0, U3
	300	D.C.	76 - 125	3,000	1	TC1, OL0, U3
	440	D.C.	1 - 30	10,000	2	TC1, OL0, U3
	440	D.C.	31 - 63	5,000	2	TC1, OL0, U3
	600	D.C.	1 - 75	5,000	2	TC1, OL0, U3
	600	D.C.	76 - 115	3,000	2	TC1, OL0, U3
SWITCH ONLY ¹	600	D.C.	1 - 115	----	2 or 3	---

Notes:

1 Requires inclusion of a relay trip voltage coil

Table C: Lists UL Listed (UL489B) configuration and performance capabilities as a Molded Case Switch

CX SERIES TABLE C : UL489B LISTED PHOTOVATIC MOLDED CASE SWITCH						
CIRCUIT CONFIGURATION	VOLTAGE			CURRENT RATING (AMPS)	INTERRUPTING RATING (AMPS)	CONSTRUCTION NOTES
	MAX RATING	FREQUENCY	POLES			
SERIES	600	DC	2 ¹	50 - 100	600	May have a third pole that is a voltage trip pole
	600	DC	4 ²	110 - 175	600	May have a fifth pole that is a voltage trip pole

Notes:

1 Two poles in series.

2 Two poles in series in parallel with 2 poles in series.

Table D: TUV Certified Configuration to IEC / EN 60947-2. Low Voltage Switch gear and Control gear - Circuit Breakers

CX-SERIES TABLE D : TUV IEC/EN 60947-2 LOW VOLTAGE SWITCH GEAR & CONTROL GEAR / CIRCUIT BREAKER					
CIRCUIT CONFIGURATION	VOLTAGE			CURRENT RATING (AMPS)	INTERRUPTING CAPACITY
	MAX. RATING	FREQUENCY	POLES		ICS / ICU (AMPS)
SERIES	440	DC	2	1-63	4,000

*Manufacturer reserves the right to change product specification without prior notice.

Electrical

Maximum Voltage
Overload

600 VDC
50 operations at 600% of rated current for UL489, and at 150% of rated current for UL1077.

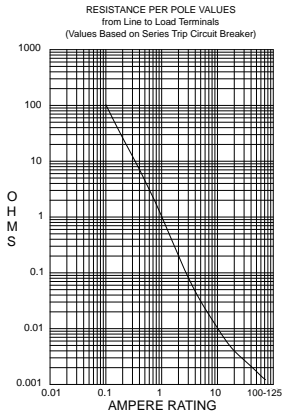

CURRENT (AMPS)	TOLERANCE (%)
0.10 - 5.0	15
5.1 - 20.0	25
20.1 - 50.0	35

Physical

Number of Poles
Termination
Terminals
Termination Barrier
Mounting
Actuator
Internal Circuit Config.
Materials

1- 2 poles, + Auxiliary Switch Pole.
10-32 or M5 Screw Terminals
1/4-20 or M6 Threaded Stud
Standard with multi-pole constructions
Threaded insert: #6-32 UNC-2B, or M3X0.5-6H B ISO (2 per pole)
Handle, 1 per pole.
Series Trip
Housing - Glass filled Polyester
Handle - Glass filled Polyester
Line/Load Terminals - Copper Alloy.
~150 Grams (~5.3 Ounces).
~150 Grams (~5.3 Ounces).
Housing - Gray.
Handle - White, Black, Red, Green, Blue, Yellow, Gray,

Weight
Standard Color

Mechanical

Endurance
Trip Free
Trip Indication

Max 10,000 ON-OFF operations @ 6 per minute; 6000 with rated current & voltage, and 4,000 cycles mechanical.
Trips on overload even when actuator is forcibly held in the "On" position.
The operating handle moves positively to the "Off" position when an overload causes the breaker to trip.

Environmental

Shock
Vibration
Moisture Resistance
Salt Spray
Thermal Shock
Operating Temperature

Withstands 100 Gs, 6ms saw tooth while carrying rated current per MIL-PRF-55629 and MIL-STD-202G, Method 213G, Test Condition "I". Instantaneous and ultra short curves tested at 90% of rated current
Withstands 0.060" excursion from 10-55 Hz & 10 Gs 55-500 Hz, at rated current per MIL-PRF-55629 and MILSTD-202G, Method 240D, Test Cond. A. Instantaneous & ultrashort curves tested at 90% of rated current.
MIL-PRF-55629 and MIL-STD-202G, Method 106G, i.e., Ten 24-hour cycles at +25°C to +65°C, 80-98% RH.
Method 101, Condition A (90-95% RH at 5% NaCl Solution, 96 hrs).
MIL-PRF-55629 and MIL-STD-202G, Method 107G, Condition A (5-cycles at -55°C to +25°C to +85°C to +25°C).
-40°C to +85°C.



1 SERIES
C

2 ACTUATOR
X Handle, one per pole

3 POLES
1 One
2 Two

4 CIRCUIT
B Series Trip (current)

5 AUXILIARY/ALARM SWITCH
0 Without Aux Switch

6 FREQUENCY & DELAY
11 DC Ultra Short
12 DC Short
14 DC Medium
16 DC Long

7 CURRENT RATING (AMPERES)

CODE	AMPERES						
220	0.20	295	0.95	460	6.00	614	14.00
225	0.25	410	1.00	465	6.50	615	15.00
230	0.30	512	1.25	470	7.00	616	16.00
235	0.35	415	1.50	475	7.50	617	17.00
240	0.40	517	1.75	480	8.00	618	18.00
245	0.45	420	2.00	485	8.50	620	20.00
250	0.50	522	2.25	490	9.00	622	22.00
255	0.55	425	2.50	495	9.50	624	24.00
260	0.60	527	2.75	610	10.00	625	25.00
265	0.65	430	3.00	710	10.50	630	30.00
270	0.70	435	3.50	611	11.00	635	35.00
275	0.75	440	4.00	711	11.50	640	40.00
280	0.80	445	4.50	612	12.00	645	45.00
285	0.85	450	5.00	712	12.50	650	50.00
290	0.90	455	5.50	613	13.00		

8 TERMINAL
2 Screw Terminal, 10-32
3 Stud, 1/4-20
5 Screw Terminal, M5
6 Stud, M6

9 ACTUATOR COLOR & LEGEND

Actuator Color	I-O	ON-OFF	Dual	Legend Color
White	A	B	1	Black
Black	C	D	2	White
Red	F	G	3	White
Green	H	J	4	White
Blue	K	L	5	White
Yellow	M	N	6	Black
Gray	P	Q	7	Black
Orange	R	S	8	Black

10 MOUNTING INSERTS
A 6-32 Thread
B M3 Thread

11 MAX. APPLICATION RATING
12 250 VDC
13 250/500 VDC ¹
15 205/410 VDC

12 AGENCY APPROVAL
A Without Approvals
G UL 489 Listed
S UL 489 Listed, TUV to IEC60947-2 ¹

Notes:
¹ Only Available with 250/500 VDC up to 15 amps.

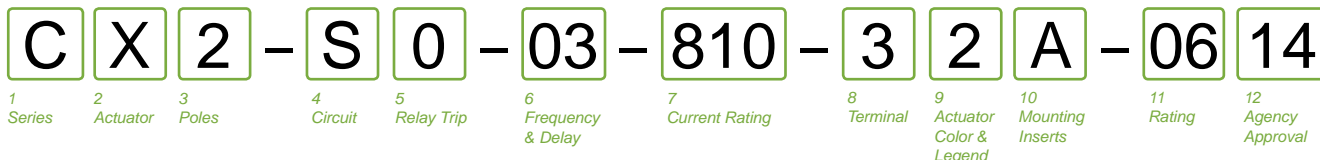

1 SERIES
C

2 ACTUATOR

X Handle, one per pole

3 POLES ^{1,2}

- 2** Two
- 3** Three
- 4** Four
- 5** Five

4 CIRCUIT

S Switch Only

5 RELAY TRIP VOLTAGE COIL RATING ^{1,2}

- 0** Without Relay Trip Voltage Coil
- A** 12 VDC
- B** 24 VDC
- C** 32 VDC
- D** 48 VDC

6 FREQUENCY & DELAY

03 DC Switch Only

7 CURRENT RATING (AMPERES) ^{1,3}

2-Pole Section

810 50A - 100A

4-Pole Section

917 110A - 175A

8 TERMINAL ^{4,5}

- 3** Stud, 1/4-20
- 6** Stud, M6
- A** Stud, 1/4-20, with 10-32 Screw Terminals on Voltage Pole
- B** Stud, M6, with M5 Screw Terminals on Voltage Pole

9 HANDLE COLOR & LEGEND

Actuator Color	I-O	ON-OFF	Dual	Legend Color
White	A	B	1	Black
Black	C	D	2	White
Red	F	G	3	White
Green	H	J	4	White
Blue	K	L	5	White
Yellow	M	N	6	Black
Gray	P	Q	7	Black
Orange	R	S	8	Black

10 MOUNTING INSERTS

- A** 6-32 Thread
- B** M3 Thread

11 MAX. APPLICATION RATING

06 600VDC

12 AGENCY APPROVAL

- A** Without Approvals
- 14** UL489B Listed

Notes:

- 1 2 Pole Unit is required for ratings between 50A - 100A.
4 Pole Unit is required for ratings between 110A - 175A.
- 2 A Relay Trip Voltage Coil Pole may be added to either the 2 or 4 Pole construction. The addition of this extra pole dictates a change in the designation for the number of poles in selection 3.
- 3 For Current Ratings between 50A - 100A select current code 810 (100A). For Current Ratings between 101A - 175A select current code 917 (175A).
- 4 Voltage Pole must have screw terminals.
Switch Pole must have stud terminals.
- 5 On 3 Pole Unit, Voltage Pole to be located at P1 as standard.
On 5 Pole Unit, Voltage Pole to be located at P3 as standard.

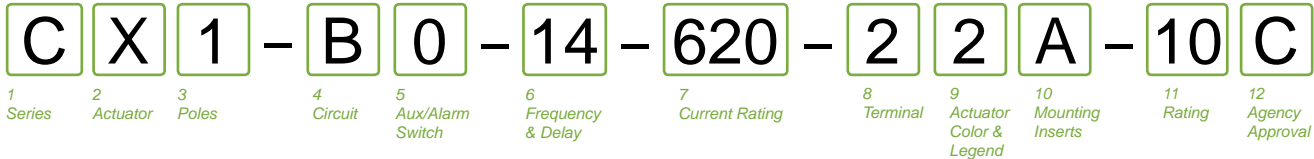

1 SERIES
C

2 ACTUATOR
X Handle, one per pole

3 POLES⁷
1 One
2 Two
3 Three
4 Four¹⁰

4 CIRCUIT
A Switch Only (no coil)^{1, 9}
B Series Trip (current)
G Relay Trip (voltage)^{1, 2, 3, 9}

5 AUXILIARY SWITCH
0 Without Aux Switch

6 FREQUENCY & DELAY
03 DC 50/60Hz, Switch Only
10 DC Instantaneous
11 DC Ultra Short
12 DC Short
14 DC Medium
16 DC Long

7 CURRENT RATING (AMPERES)⁶

CODE	AMPERES				
220	0.200	415	1.500	490	9.000
225	0.250	517	1.750	495	9.500
230	0.300	420	2.000	610	10.000
235	0.350	522	2.250	710	10.500
240	0.400	425	2.500	611	11.000
245	0.450	527	2.750	711	11.500
250	0.500	430	3.000	612	12.000
255	0.550	435	3.500	712	12.500
260	0.600	440	4.000	613	13.000
265	0.650	445	4.500	614	14.000
270	0.700	450	5.000	615	15.000
275	0.750	455	5.500	616	16.000
280	0.800	460	6.000	617	17.000
285	0.850	465	6.500	618	18.000
290	0.900	470	7.000	620	20.000
295	0.950	475	7.500	622	22.000
410	1.000	480	8.000	624	24.000
512	1.250	485	8.500	625	25.000

8 TERMINAL⁸
2 Screw, 10-32
3 Stud, 1/4-20
5 Screw, M5
6 Stud, M6

9 ACTUATOR COLOR & LEGEND

Actuator Color	I-O	ON-OFF	Dual	Legend Color
White	A	B	1	Black
Black	C	D	2	White
Red	F	G	3	White
Green	H	J	4	White
Blue	K	L	5	White
Yellow	M	N	6	Black
Gray	P	Q	7	Black
Orange	R	S	8	Black

10 MOUNTING INSERTS
A 6-32 Thread
B M3 Thread

11 MAX. APPLICATION RATING
10 300VDC
11 440 VDC without factory installed terminal bus⁴
14 440VDC with factory installed terminal bus⁴
06 600VDC⁵

12 AGENCY APPROVAL
A Without Approvals
C UL 1077 Recognized
W UL 1077 Recognized & TUV Certified IEC/ EN 60947-2⁹

- Notes:
- 1 Only available when tied to a protected pole
Requires special P/N consult factory for details
 - 2 Voltage trip circuit coil not rated for continuous duty - use instantaneous delay code 10
 - 3 Contacts Rated for 20A @ 80 VDC
 - 4 440VDC Rating available in two different wiring configurations.
(see next page for more details)
 - 5 600 VDC only available with factory installed terminal bus (see next page for more details)
 - 6 Single pole units available up to 125A, multi pole units limited to 115A Max.
(see next page for more details)
 - 7 3 Pole units must include one Auxiliary switch pole (circuit code A or G) - Requires Special Part Number. (see next page for more details)
 - 8 Screw Terminals are limited to 50A max.
 - 9 Agency approval code W only available with 440 VDC rating & circuit code B.
 - 10 4 Pole 600 VDC units only available up to 75A Max. (see next page for more details)

Dimensional Specifications: in. [mm]

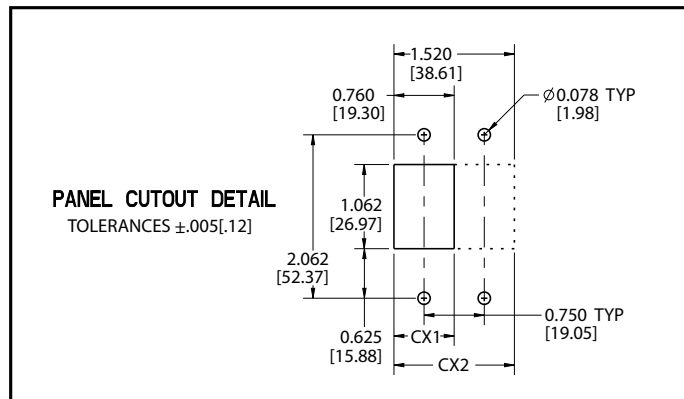
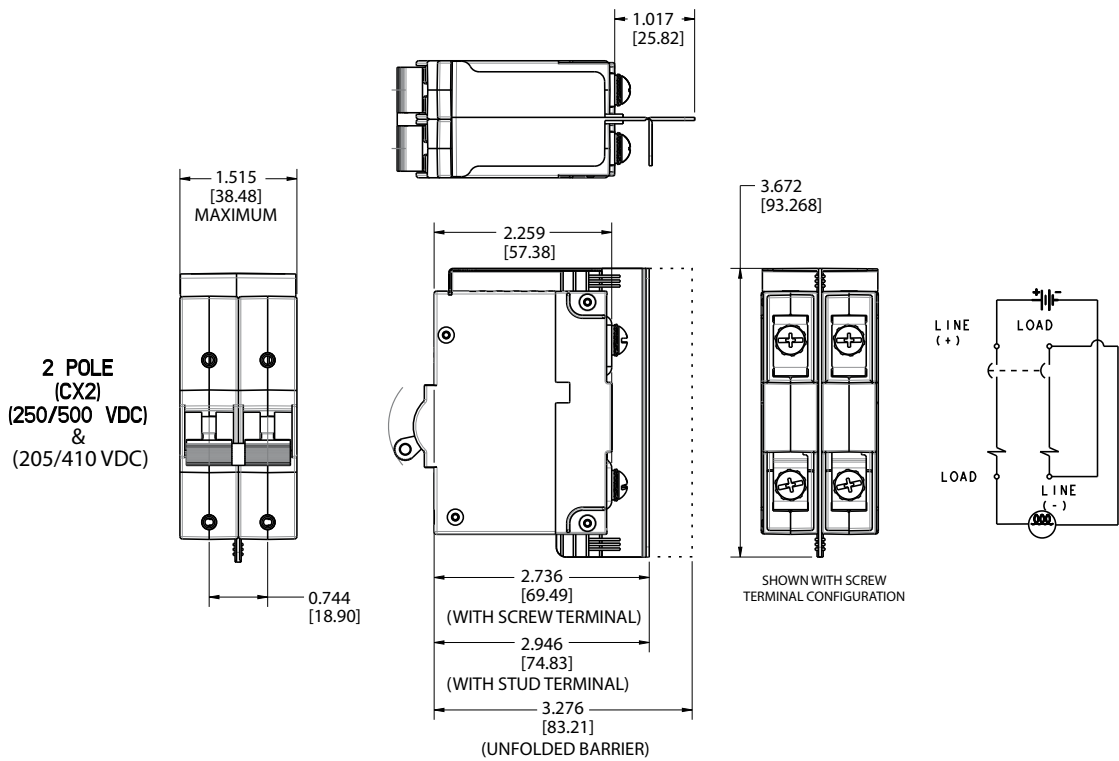
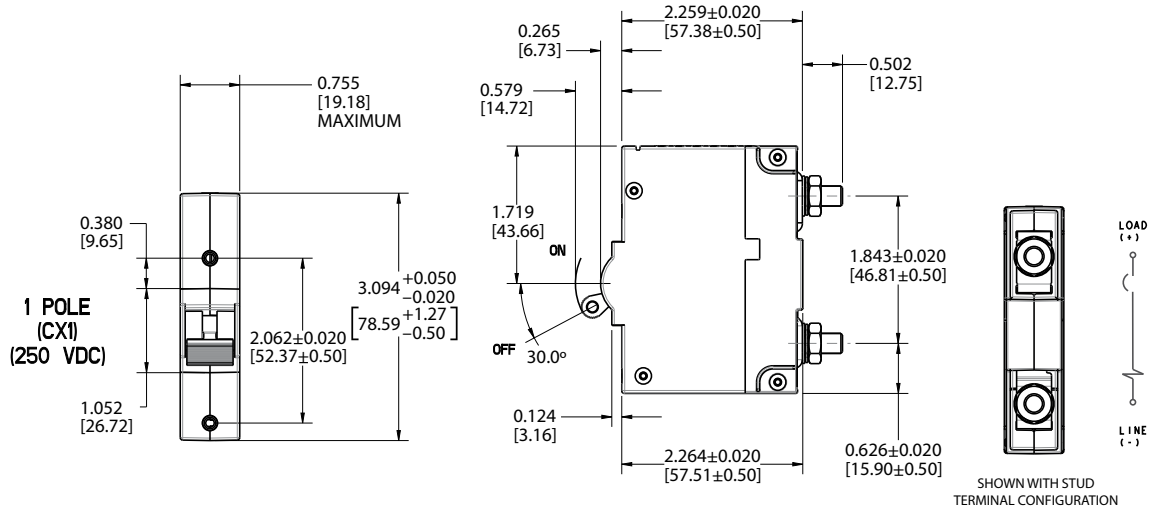

Notes:

- 1 All dimensions are in inches [millimeters].
- 2 Tolerance ± 0.020 [51] unless otherwise specified.

Dimensional Specifications: in. [mm]

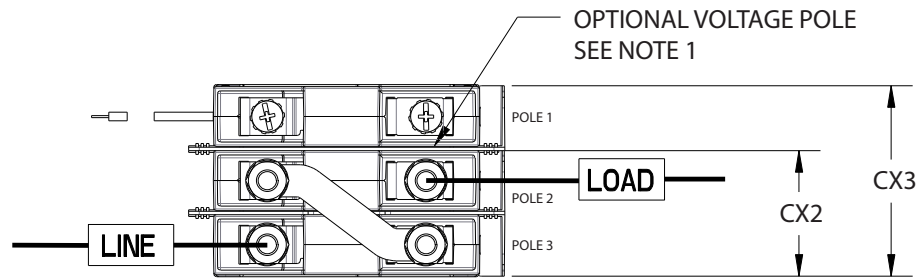
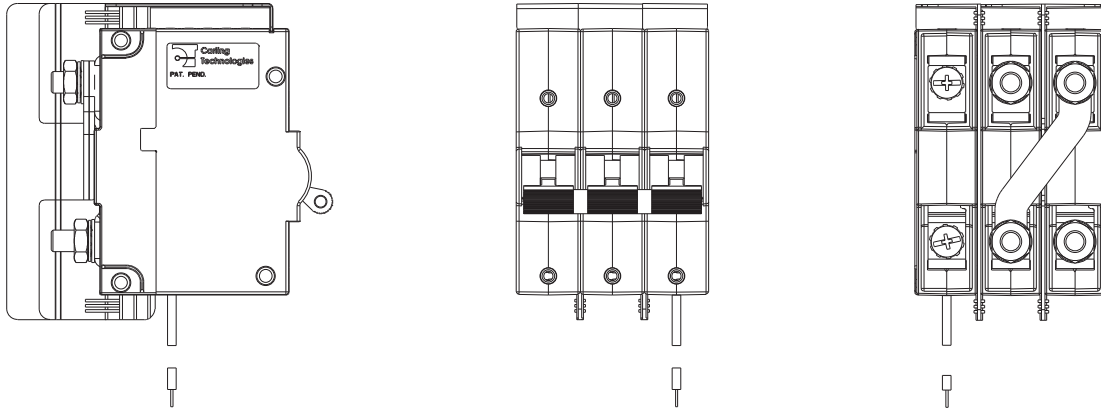

CX3 - 2 POLE SWITCH (CX2) SHOWN
WITH OPTIONAL VOLTAGE POLE
50A-100A DEVICE, 600VDC

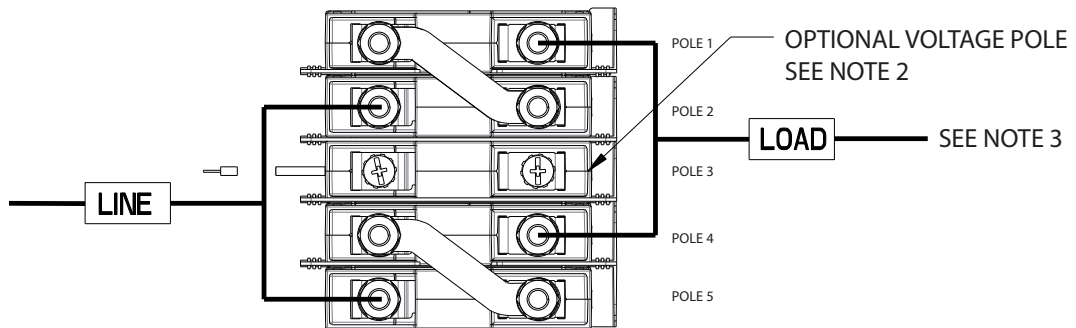

CX5 - 4 POLE SWITCH (CX4) SHOWN
WITH OPTIONAL VOLTAGE POLE
101A-175A DEVICE, 600VDC

Notes:

- 1 All dimensions are in inches [millimeters].
- 2 3 pole configuration supplied with voltage coil on pole 1. Optional location pole 3. Consult factory.
- 3 5 pole configuration supplied with voltage coil in center pole. (Pole 3)
- 4 Line & Load connections requires bus connection as shown.
Minimum cross section .127 in² (81.94 mm²)

Dimensional Specifications: in. [mm]

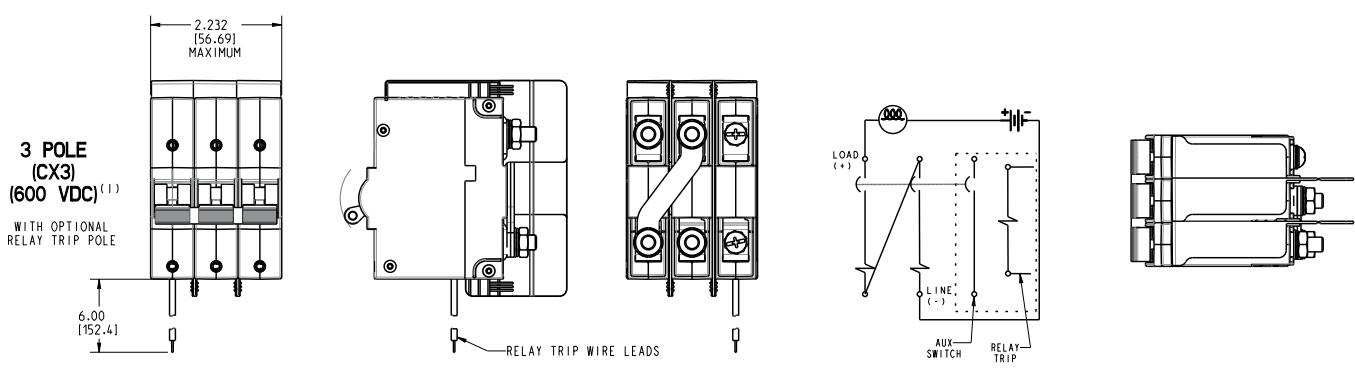
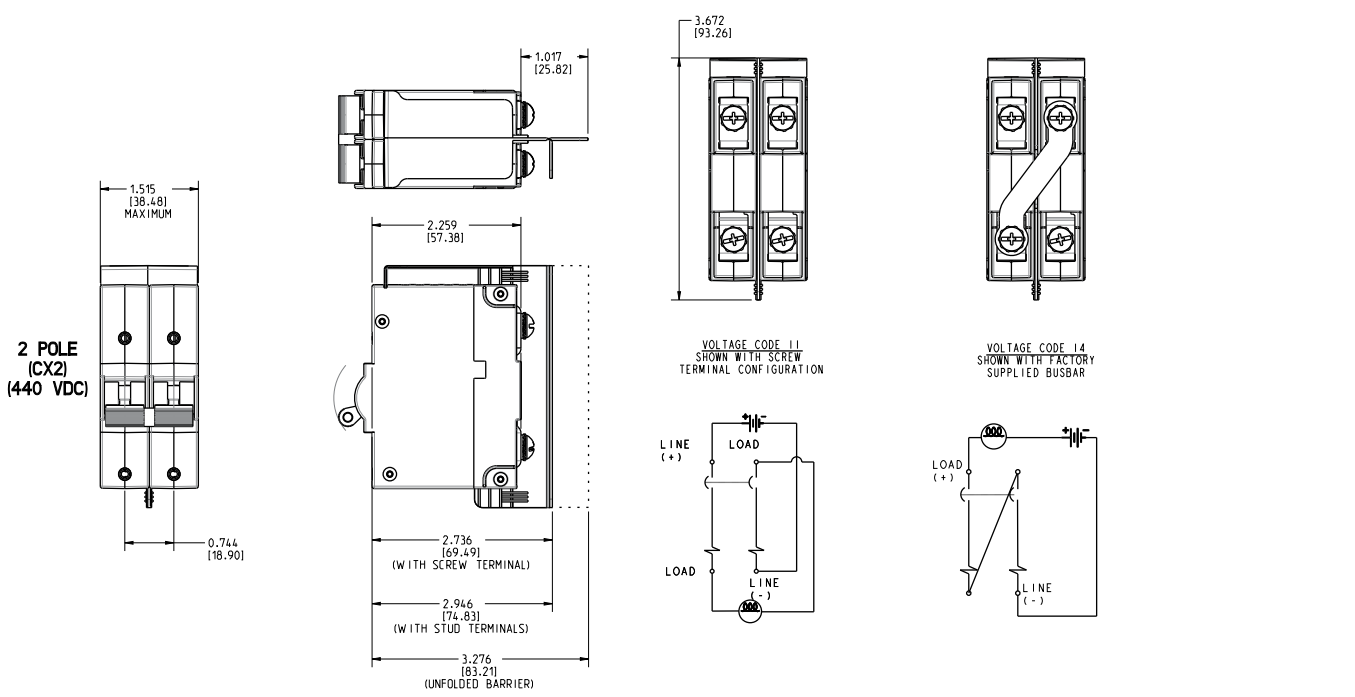
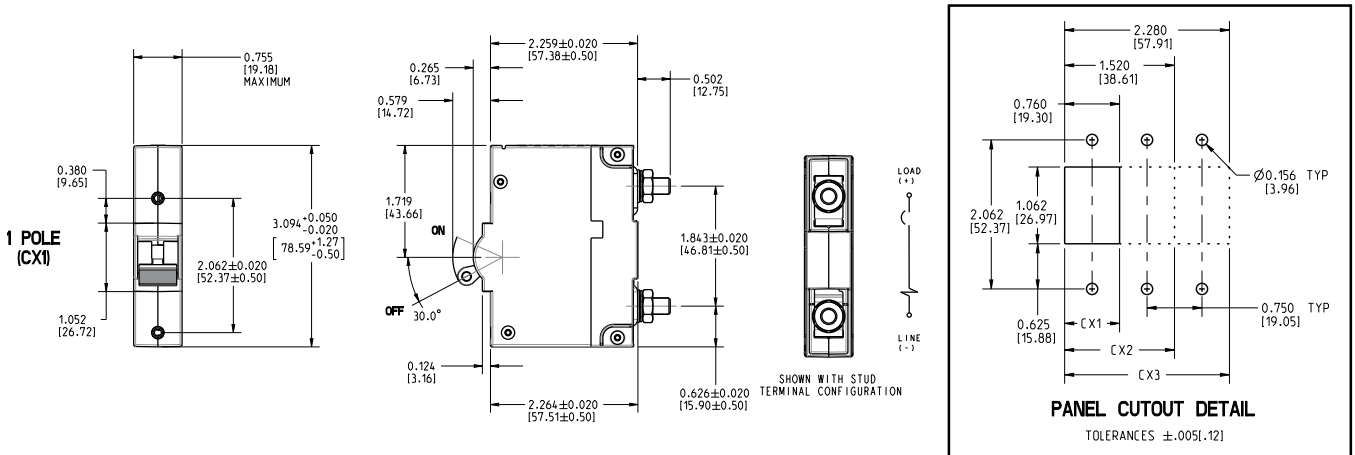

- Notes:
- 1 All dimensions are in inches [millimeters].
 - 2 600V Rating requires minimum of 2 protected poles

C-Series

CIRCUIT BREAKER

The C-Series hydraulic-magnetic circuit breakers are ideal for applications that require higher amperage and voltage handling capability in a smaller package. They are available in 1-6 poles, 0.02-100amps, UL Recognized up to 480VAC or 150VDC, UL489 Listed up to 240VAC or 125VDC, with choice of time delays, terminal options, actuator styles and colors. The C-Series employs a unique arc chute design which allows for higher interrupting capacities of up to 10,000 amps. Thermoset glass filled polyester half shell construction provides for increased mechanical and electrical strength. The wiping contacts mechanical linkage, with two step actuation, cleans contacts providing high, positive contact pressure and longer contact life. Available with American Standard or Metric Threaded Stud terminals, or Saddle Clamp screw terminals. The optional mid-trip handle style actuator allows a visual indication of electrical overload with or without alarm feature.



Product Highlights:

- Extensive list of Agency Approvals
- Available with Standard or Metric Stud terminals, or Saddle Clamp screw terminals
- Optional mid-trip handle style actuator
- Unique arc chute design which allows for higher interrupting capacities of up to 10,000 amps
- Exclusive Rockerguard and Push-To-Reset bezel
- Available with new solid color and two-color Visi-rocker® actuators
- New thermoset glass filled polyester half shell construction

Only Renewable Energy applicable ordering schemes and drawings are shown in this catalog. For complete product details, please visit www.carlingtech.com

Electrical

Maximum Voltage AC, 480 WYE/277 VAC, 50/60 Hz (see Table A.)
 UL489: AC,240 VAC. (See Table D), 50/60 Hz, 125 VDC

Current Rating Standard current coils: 0.100, 0.250, 0.500, 0.750, 1.00, 2.50, 5.00, 7.50, 10.0, 15.0, 25.0, 30.0, 35.0, 40.0, 50.0, 60.0, 70.0, 80.0, 90.0 and 100 amps. Other ratings available, see Ordering Scheme.

Standard Voltage Coils DC - 6V, 12V; AC - 120V; other ratings available, see Ordering Scheme.

Auxiliary Switch Rating SPDT; 10.1 amps-250VAC, DC Aux. Switch 1.0A, 65 VDC. 0.5A, 80VDC,1/4 HP, 125VAC,VDE & TUV 1.0 125 VAC.

Insulation Resistance Minimum of 100 Megohms at 500 VDC.

Dielectric Strength UL, CSA: 1960 V 50/60 Hz for one minute between all electrically isolated terminals. C-Series Circuit Breakers comply with the 8mm spacing and 3750V 50/60 Hz dielectric requirements from hazardous voltage to operator accessible surfaces, between adjacent poles and from main circuits to auxiliary circuits per Publications EN 60950 and VDE 0805.

Resistance, Impedance Values from Line to Load Terminal - based on Series Trip Circuit Breaker.

RESISTANCE, IMPEDANCE VALUES from Line to Load Terminals (Values Based on Series Trip Circuit Breaker)

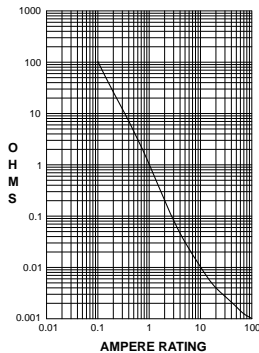

CURRENT (AMPS)	TOLERANCE (%)
0.10 - 5.0	15
5.1 - 20.0	25
20.1 - 50.0	35

Pulse Tolerance Curves

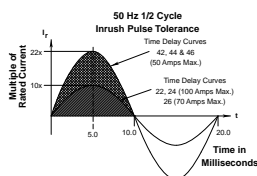
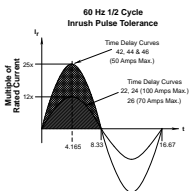

Mechanical

Endurance 10,000 ON-OFF operations @ 6 per minute; with rated current & voltage.

Trip Free All C-Series circuit breakers will trip on overload, even when actuator is forcibly held in the ON position.

Trip Indication The operating actuator moves positively to the OFF position when an overload causes the breaker to trip. With mid-trip, handle moves to the mid position on electrical trip of the circuit breaker. With mid trip handle with alarm switch, handle moves to the mid position and the alarm switch actuates when the circuit breaker is electrically tripped.

Physical

Number of Poles 1-6 poles ≤ 50A; 1-4 poles @ 51-70A; 1-2 poles 71-100A. UL489 Handle: 1 pole ≤ 100A, 2 pole ≤ 50A; Rocker: 1 pole ≤ 100A.

Internal Circuit Config. Series (with or without auxiliary switch, mid trip & mid trip with alarm switch) Shunt & Relay with current or voltage trip coils, Dual Coil, Switch Only (with or without aux. switch). UL489: Series (with or without auxiliary switch, mid-trip & midtrip with alarm switch).

Weight Approx.112 grams/pole (3.95 oz).

Standard Colors Housing: Black

Environmental

Designed and tested in accordance with requirements of specification MIL-PRF-55629 & MIL-STD-202 as follows:

Shock Withstands 100 Gs, 6ms sawtooth while carrying rated current per Method 213, Test Condition "I". Instantaneous and ultrashort curves tested @ 90% of rated current.

Vibration Withstands 0.060" excursion from 10-55 Hz & 10 Gs 55-500 Hz, @ rated current per Method 204C, Test Cond. A. Instantaneous & ultrashort curves tested @ 90% of rated current.

Moisture Resistance Method 106D, i.e., ten 24-hour cycles @ +25°C to +65°C, 80-98% RH.

Salt Spray Method 101, Condition A (90-95% RH @ 5% NaCl Solution, 96 hrs).

Thermal Shock Method 107D, Condition A (five cycles @ -55°C to +25°C to +85°C to +25°C).

Operating Temperature -40°C to +85°C

*Manufacturer reserves the right to change product specification without prior notice.

Electrical Tables

Table A: Lists UL Recognized & CSA Accepted configurations and performance capabilities as a component supplementary protector

C-SERIES TABLE A: Component Supplementary Protectors											
Circuit Configuration	Voltage			Current Rating		Short Circuit Capacity (Amps)		Application Codes		Construction Notes	
	Max. Rating	Frequency	Phase	Full Load Amps	General Purpose Amps	UL / CSA		UL	CSA		
						With Backup Fuse	Without Backup Fuse				
Series	32	DC	---	0.02 - 100	---	---	5,000	TC1, OL1, U2	TC1, OL1, U2	---	
	48	DC	---	110 - 150	---	---	5,000			---	
	65	DC	---	0.02 - 70	---	71 - 100	---	5,000	TC1, 2, OL1, U1	TC1, 2, OL1, U1	---
				-	---				TC1, 2, OL0, U1	TC1, 2, OL0, U1	---
	80	DC	---	0.02 - 70	---	71 - 100	---	7,500	TC1, 2, OL1, U1	TC1, 2, OL1, U1	---
				---	---				TC1, 2, OL0, U1	TC1, 2, OL0, U1	---
				0.02 - 70	---				10,000	TC1, 2, OL1, U1	TC1, 2, OL1, U1
	---	71 - 100	TC1, 2, OL0, U1	TC1, 2, OL0, U1							
	125	DC	---	0.02 - 50	---	---	5,000	TC1, 2, OL1, U1	TC1, 2, OL1, U1	Must have Agency "L"	
	125/250	DC	---	0.02 - 50	---	---	5,000	TC1, 2, OL1, U1	TC1, 2, OL1, U1	Must have Agency "L"	
	250	DC	---	0.02 - 50	---	---	5,000	TC1, 2, OL1, U1	TC1, 2, OL1, U1	Must have Agency "L": 250 volts requires 2 pole	
	125	50 / 60	1	0.02 - 100	---	---	---	3,000	TC1, OL1, U2	TC1, OL1, U2	Per pole rating
								5,000	TC1, 2, OL1, U1	TC1, 2, OL1, U1	Must have Agency "L"
	150	DC	---	---	---	80 - 100	---	5,000	TC1, 2, OL0, U3	---	Must have Agency "L"
	125/250	50 / 60	1	0.02 - 100	---	---	---	3,500	TC1, OL1, U2	TC1, OL1, U2	---
				0.02 - 50				3,000	TC1, 2, OL1, U1	TC1, 2, OL1, U1	2 or 3 poles breaking single phase
				51 - 100				1,000	TC1, 2, OL1, U1	TC1, 2, OL1, U1	2 or 3 poles breaking single phase
				0.02 - 100				5,000	TC1, 2, OL1, U2	TC1, 2, OL1, U2	2 or 3 poles breaking single phase. Agency "L"
	250	50 / 60	1	0.02 - 50	---	---	---	3,500	TC1, 2, OL1, U2	TC1, 2, OL1, U2	Per pole rating
				0.02 - 100				5,000	TC1, 2, OL1, U1	TC1, 2, OL1, U1	Must have Agency "L"
				51 - 70				5,000	---	---	---
			3	---	0.02 - 100	---	3,000	TC1, 2, OL0, U2	TC1, 2, OL0, U2	---	
---				0.02 - 70	---	5,000	---	---	3 poles breaking 3 phase		
---	---	0.02 - 90	---	5,000	TC1, 2, OL0, U1	TC1, 2, OL0, U1	Must have Agency "L"				
277	50 / 60	1	0.02 - 50	---	---	5,000	---	---	---		
480/277	50 / 60	3	0.02 - 30	---	---	---	5,000	---	---	3 poles breaking 3 phase	
							---	---	---	---	---
480	50 / 60	1	0.02 - 30	---	---	---	5,000	---	---	2 poles breaking 1 phase	
							---	---	---	---	---
Dual Coil	80	DC	---	0.02 - 50	---	---	7,500	TC1, 2, OL1, U1	TC1, 2, OL1, U1	---	
	125	50 / 60	1	0.02 - 50	---	---	3,000	TC1, OL1, U2	TC1, OL1, U2	Per pole rating	
	125/250	50 / 60	1	0.02 - 50	---	---	---	3,500	TC1, OL1, U2	TC1, OL1, U2	2 or 3 poles breaking single phase
								3,000	TC1, 2, OL1, U1	TC1, 2, OL1, U1	2 or 3 poles breaking single phase
	250	50 / 60	1	0.02 - 50	---	---	---	3,500	TC1, OL1, U2	TC1, OL1, U2	---
			3					3,000	TC1, OL0, U2	TC1, OL0, U2	Per pole rating
	---	---	---	---	---	---	---	5,000	---	---	---
277	50 / 60	1	0.02 - 50	---	---	---	5,000	---	---	3 poles breaking 3 phase	
Shunt	80	DC	---	0.02 - 50	---	---	7,500	TC1, 2, OL1, U1	TC1, 2, OL1, U1	---	
	277	50 / 60	1	0.02 - 50	---	---	5,000	---	---	---	
	250	50 / 60	3	0.02 - 50	---	---	---	5,000	---	---	3 poles breaking 3 phase
								---	---	---	---
	480/277	50 / 60	3	0.02 - 30	---	31 - 50	---	5,000	---	---	3 poles breaking 3 phase
				---	---			---	---	---	
480	50 / 60	1	0.02 - 30	---	31 - 50	---	5,000	---	---	2 poles breaking 1 phase	
			---	---			---	---	---		
Relay	80	DC	---	0.02 - 50	---	---	7,500	TC1, 2, OL1, U1	TC1, 2, OL1, U1	---	
	277	50 / 60	1	0.02 - 50	---	---	5,000	---	---	---	
	250	50 / 60	3	0.02 - 50	---	---	5,000	---	---	3 poles breaking 3 phase	
Switch Only	65	DC	---	71 - 100	---	---	---	---	---	---	
				---	---	---	---	---			
	80	DC	---	71 - 100	---	---	---	---	---		
	125	50 / 60	1	0.02 - 100	---	---	---	---	---		
	125/250	50 / 60	1	0.02 - 100	---	---	---	---	---	2 or 3 poles breaking single phase	
			3	0.02 - 100	---	---	---	---	---		
	250	50 / 60	1	0.02 - 70	---	---	---	---	---	---	
3			0.02 - 70	---	---	---	---	---			
277	50 / 60	1	0.02 - 50	---	---	---	---	---			
480/277	50 / 60	3	0.02 - 30	---	31 - 50	---	---	---	---	3 poles breaking 3 phase	
			---	---			---	---	---		

Notes:

- Requires branch circuit backup with a UL LISTED Type K5 or RK5 fuse rated 15A minimum and no more than 4 times full load amps not to exceed 125A for 50 Amp or less rating and not to exceed 175 for 51 through 100 Amp rating

Electrical Tables

Table B: Lists UL Recognized and CSA Accepted configurations and performance capabilities as a Manual Motor Controller.

C-SERIES TABLE B: Manual Motor Controllers					
Circuit Configuration	Voltage			Current Rating	Horsepower Ratings
	Max. Rating	Frequency	Phase	Full Load Amps	Max. HP
Series, Shunt & Relay Switch Only	120 ¹	50 / 60	1	0.02 - 50	7 1/2
	250 ¹	50 / 60	1	0.02 - 20	3
			3	0.02 - 20	5
	277 ¹	50 / 60	1	0.02 - 20	3
480 ²	50 / 60	3	0.02 - 20	5	

- Notes:
- Requires branch circuit backup with a UL Listed Type K5 or RK5 fuse rated 15A Minimum and no more than 4 times full load amps not to exceed 125A for 50 Amp or less rating and not to exceed 175A for 51 through 100A rating.
 - UL Recognized and CSA Certified at 480V refers to 3 and 4 pole versions used in a 3Ø, WYE connected circuit or a 2 pole version with 2 poles breaking 1Ø and backed up with a series fusing as stated in note 1.
- * Shunt and Relay Trip - Voltage Coil Construction not current coils

Table C: Lists UL Recognized, CSA Accepted, VDE and TUV Certified configurations and performance capabilities as a Component Supplementary Protector.

C-SERIES TABLE C: Component Supplementary Protectors														
Circuit Configuration	Voltage			Current Rating		Short Circuit Capacity (Amps)						Application Codes UL / CSA	Construction Notes	
	Max. Rating	Frequency	Phase	Full Load Amps	General Purpose Amps ¹	UL / CSA		VDE		TUV				
						With Backup Fuse	Without Backup Fuse	(Inc) With Backup Fuse	(Inc) Without Backup Fuse	(Inc) With Backup Fuse	(Inc) Without Backup Fuse			
Series	80	DC	---	0.10 - 70	---	---	7,500	---	5,000	5,000	1,500	TC1,2,OL1,U1	---	
				71 - 100	71 - 100	---	10,000	---	5,000	---	5,000	TC1,2,OL0,U1	Agency F, H, J or R	
	250	50 / 60	1	1 - 50	---	---	---	---	---	---	5,000	---	TC1,2,OL1,U1	Agency J or R
				0.10 - 50	---	---	---	---	---	---	5,000	---	2P, Agency J or R	
				0.10 - 70	---	---	5,000	---	---	---	---	---	---	---
				0.10 - 100	---	---	---	---	---	---	---	5,000	5,000	TC1,2,OL1,U1
415	50 / 60	3	0.10 - 30	---	---	5,000 ²	---	3,000	1,500	3,000	1,500	TC1,2,OL1,C1	Rocker	
			0.10 - 90	---	---	---	---	5,000	2,500	---	---	---	Handle, Agency F, H, J or R	
Dual Coil	80	DC	---	0.10 - 30	---	---	7,500	---	1,500	5,000	1,500	TC1,2,OL1,U1	---	
	250	50 / 60	1 & 3		---	---	5,000	3,000	---	3,000	---	---		
Shunt	80	DC	---	0.10 - 70	---	---	7,500	---	5,000	5,000	1,500	TC1,2,OL1,U1	---	
	250	50 / 60	1 & 3	0.10 - 70	---	---	5,000	3,000	1,500	3,000	1,500	TC1,2,OL1,U1	---	
	415	50 / 60	3	0.10 - 30	---	---	5,000 ²	---	3,000	1,500	3,000	1,500	TC1,2,OL1,C1	Rocker Handle, Agency F, H, J or R

- Notes:
- General Purpose ratings for UL/CSA only.
 - Requires branch circuit backup with a UL LISTED Type K5 or RK5 fuse rated 15A minimum and no more than 4 times full load amps not to exceed 125A for 50 Amp or less rating and not to exceed 175 for 51 through 100 Amp rating.

Table D: Lists UL Listed (489), CSA Certified (C22.2 No. 5.1-M) configuration and performance capabilities as a Molded Case Circuit Breaker.

C-SERIES TABLE D: UL489 Listed Branch Circuit Breakers							
Circuit Configuration	Voltage			Current Rating	Interrupting Capacity (Amps)		Construction Notes
	Max. Rating	Frequency	Phase	Full Load Amps	Without Backup Fuse		
Series	80	DC	---	0.10 - 100	50,000 ¹		Limited to 2 Poles Max from 71 - 100 Amps
				101 - 150	10,000		
				151 - 250	10,000		
	125	DC	---	0.10 - 100	5,000		1 - 3 Poles
	125 / 250	DC	---	0.10 - 50	5,000		1 or 2 Poles (2 poles required for 250 Volts)
	120	50 / 60	1	0.10 - 50	10,000		1 - 3 Poles
				51 - 70	5,000		
	120 / 240	50 / 60	1	0.10 - 50	5,000		2 or 3 Poles (1 pole of a 3 pole unit is neutral)
					10,000 ¹		
	240	50 / 60	1	0.10 - 30	5,000		1 Pole
0.10 - 20				10,000		2 Poles	
277	50 / 60	1	0.10 - 20	10,000		1 Pole	
Dual Coil	120	50 / 60	1	0.10 - 30	10,000		---

- Notes:
- Special catalog number required. Consult factory.

Electrical Tables

Table E: Lists UL Recognized, CSA Accepted configurations and performance capabilities as Protectors, Supplementary for Marine Electrical and Fuel Systems (Guide PEQZ2, File E75596). Ignition Protected per UL 1500. UL Classified Small Craft Electrical Devices, Marine in accordance with ISO 8846 (Guide UZMK, File MQ1515) as Marine Supplementary Protectors.

C-SERIES TABLE E: UL1500 (Marine Ignition Protection)								
Circuit Configuration	Voltage			Current Rating	Interrupting Capacity (Amps)	Application Codes		Construction Notes
	Max. Rating	Frequency	Phase	Full Load Amps	Without Backup Fuse	UL	CSA	
Series	48	DC	---	0.02 - 100	5,000	TC1, 2, OL1, U1	TC1, 2, OL1, U1	---
				101 - 150				
	65	DC	---	0.02 - 100	1,500	TC1, 2, OL0, U1	TC1, 2, OL0, U1	---
	80	DC	---	0.02 - 70	1,500	TC1, 2, OL1, U1	TC1, 2, OL1, U1	---
	125	50 / 60	1	0.02 - 70	5,000	TC1, 2, OL1, U1	TC1, 2, OL1, U1	---
				71 - 100	1,500			
	250	50 / 60	1	0.02 - 70	1,500	TC1, 2, OL1, U1	TC1, 2, OL1, U1	---
				71 - 100				2 Poles Breaking Single Phase

Table F: Lists UL Listed configurations and performance capabilities as Circuit Breakers for use in Communications Equipment (Guide DITT, File E189195), under UL489A.

C-SERIES TABLE F: PARALLEL POLE CONSTRUCTION UL489A Listed for Communications Equipment				
Circuit Configuration	Voltage		Current Rating	Interrupting Capacity (Amps)
	Max. Rating	Frequency	General Purpose Amps	Without Backup Fuse
Series	80	DC	100 - 250	10,000

Agency Certifications

UL Recognized

UL Standard 1077



Component Recognition Program as Protectors Supplementary (Guide CCN/QVNU2, File E75596)

CSA Accepted



Component Supplementary Protector under Class 3215 30, File 047848 0 000 CSA Standard C22.2 No. 235

UL Standard 508



Switches, Industrial Control (Guide CCN/NRNT2, File E148683)

CSA Certified



Circuit Breaker Model Case (Class 1432 01, File 093910), CSA Standard C22.2 No. 5.1 - M

UL Standard 1500



Protectors, Supplementary for Marine Electrical & Fuel Systems (Guide PEQZ2, File E75596) Ignition Protection

TUV Certified



EN60934, under License No. R72040875

UL Listed

UL Standard 489



Circuit Breakers, Molded Case, (Guide DIVQ, File E129899)

VDE Certified



EN60934, VDE 0642 under File No. 10537

UL Standard 489A



Communications Equipment (Guide CCN/DITT, File E189195)

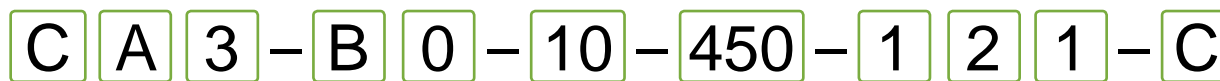

1 Series 2 Actuator 3 Poles 4 Circuit 5 Aux/Alarm Switch 6 Frequency & Delay 7 Current Rating 8 Terminal 9 Actuator Color 10 Mounting Bezel/Barrier 11 Agency Approval

1 SERIES
C

2 ACTUATOR¹
A Handle, one per pole
B Handle, one per multipole unit
S Mid-Trip Handle, one per pole
T Mid-Trip Handle, one per pole & Alarm Switch

3 POLES²
1 One **3** Three **5** Five
2 Two **4** Four **6** Six

4 CIRCUIT³
A³ Switch Only (No Coil) **F⁴** Relay Trip (Current)
B Series Trip (Current) **G⁴** Relay Trip (Voltage)
C Series Trip (Voltage) **H^{4,5}** Dual Coil with Shunt Trip Voltage Coil
D⁴ Shunt Trip (Current) **K^{4,5}** Dual Coil with Relay Trip Voltage Coil
E⁴ Shunt Trip (Voltage)

5 AUXILIARY / ALARM SWITCH
0 without Aux Switch
2 S.P.D.T., 0.110 Q.C. Term. **6** S.P.S.T., 0.139 Solder Lug
3 S.P.D.T., 0.139 Solder Lug **8** S.P.S.T., 0.187 Q.C. Term.
4 S.P.D.T., 0.110 Q.C. Term. (Gold Contacts) **9** S.P.D.T., 0.187 Q.C. Term.

6 FREQUENCY & DELAY
03³ DC 50/60Hz, Switch Only **30** DC 50/60Hz Instantaneous
10⁷ DC Instantaneous **31** DC 50/60Hz Ultra Short
11 DC Ultra Short **32** DC 50/60Hz Short
12 DC Short **34** DC 50/60Hz Medium
14 DC Medium **36** DC 50/60Hz Long
16 DC Long **42⁸** 50/60Hz Short, Hi-Inrush
20⁷ 50/60Hz Instantaneous **44⁸** 50/60Hz Medium, Hi-Inrush
21 50/60Hz Ultra Short **46⁸** 50/60Hz Long, Hi-Inrush
22 50/60Hz Short **52⁸** DC Short, Hi-Inrush
24 50/60Hz Medium **54⁸** DC Medium, Hi-Inrush
26 50/60Hz Long **56** DC Long, Hi-Inrush

Notes:

- 1 Actuator Code:
 A: Handle tie pin spacer(s) and retainers provided assembled with multi-pole units.
 B: Handle location as viewed from front of breaker:
 2 pole - left pole 3 pole - center pole 4 pole - two handles at center poles
 5 pole - three handles at center poles 6 pole - four handles at center poles
 S: Handle moves to mid-position only upon electrical trip of the breaker. Available with circuit codes B, C, D, E, F, G, H and K.
 T: Handle moves to mid-position and alarm switch activates only upon electrical trip of the breaker. Available with circuit codes B & C.
- 2 Standard multipole units have all poles identical except when specifying auxiliary switch and/or mixed poles. 4 pole max with VDE. 5th pole available as Series Trip with Voltage Coil only.
- 3 Switch Only circuits, rated up to 50 amps and 6 poles, and only available with VDE Certification when tied to a protected pole (Circuit Code B, C, D or H.). For .02 to 30 amps, select Current Code 630. For 35 - 50 amps, select Current Code 650. For 55-70 amps, select Current Code 670. For 75-100 amps, select Current Code 810. Circuit Codes D,E,F,G,H & K available with Terminal Codes 1,2,4 & 5 only. Circuit Codes D, F, H & K available up to 50 amps maximum Current Rating.
- 5 Consult factory for available Dual Coil options, as special catalog number is required. Dual Coil Voltage Coils with Shunt Trip Construction trip instantaneously on line voltage. Dual Coil Voltage Coils require 30VA minimum power to trip instantaneously and are rated for intermittent duty only.
- 6 Auxiliary Switch available with Series Trip and Switch Only circuits. On multi-pole breakers, one auxiliary switch is supplied, mounted in the extreme right pole.
- 7 Voltage coils not rated for continuous duty. Available only with delay codes 10 & 20.
- 8 Available with Circuit Codes B & D only, and up to 50 amps maximum.
- 9 Current Ratings 60 - 70 are available up to four poles maximum. Ratings 71 - 100 are available up to two poles maximum.
- 10 Terminal Code 1 available to 60 amps maximum.
- 11 Terminal Codes 2, 4, 5 and C available to 50 amps maximum.
- 12 Terminal Codes 3, 6 & 9 available to 100 amps maximum.
- 13 Terminal Code 7 available to 25 amps maximum.
- 14 Terminal Code A available to 100 amps maximum.
- 15 Terminal Codes 7, 9 & C are not VDE approved.
- 16 No marking available. Consult factory. VDE/TUV Approval requires dual (I-O, ON-OFF) or I-O markings on all handles.
- 17 Single pole only.
- 18 VDE/TUV: 30 amps max.; UL/CSA: 50 amps max.; Available in 2 - 4 poles only and limited to AC Delays. "General Purpose amps" not rated for "full load amps" or to be used in applications with a motor.

7 CURRENT RATING (AMPERES)

CODE	AMPERES	CODE	AMPERES	CODE	AMPERES	CODE	AMPERES
020	0.020	235	0.350	430	3.000	614	14.000
025	0.025	240	0.400	435	3.500	615	15.000
030	0.030	245	0.450	440	4.000	616	16.000
035	0.035	250	0.500	445	4.500	617	17.000
040	0.040	255	0.550	450	5.000	618	18.000
045	0.045	260	0.600	455	5.500	620	20.000
050	0.050	265	0.650	460	6.000	622	22.000
055	0.055	270	0.700	465	6.500	624	24.000
060	0.060	275	0.750	470	7.000	625	25.000
065	0.065	280	0.800	475	7.500	630	30.000
070	0.070	285	0.850	480	8.000	635	35.000
075	0.075	290	0.900	485	8.500	640	40.000
080	0.080	295	0.950	490	9.000	650	50.000
085	0.085	410	1.000	495	9.500	660 ⁹	60.000
090	0.090	512	1.250	610	10.000	670 ⁹	70.000
095	0.095	415	1.500	710	10.500	680 ⁹	80.000
210	0.100	517	1.750	611	11.000	685 ⁹	85.000
215	0.150	420	2.000	711	11.500	690 ⁹	90.000
220	0.200	522	2.250	612	12.000	695 ⁹	95.000
225	0.250	425	2.500	712	12.500	810 ⁹	100.00
230	0.300	527	2.750	613	13.000		

OR VOLTAGE COIL (NORMAL RATED VOLTAGE)⁷

CODE	AMPERES	CODE	VOLTS	CODE	VOLTS	CODE	VOLTS
A06	6 DC	A32	32 DC	J12	12 AC	J65	65 AC
A12	12 DC	A48	48 DC	J18	18 AC	K20	120 AC
A18	18 DC	A65	65 DC	J24	24 AC	L40	240 AC
A24	24 DC	J06	6 AC	J48	48 AC		

8 TERMINAL¹⁵

CODE	TERMINAL	CODE	TERMINAL
1 ¹⁰	Stud 10-32	6 ¹²	Stud M6
2 ¹¹	Screw 10-32	7 ^{13,15}	0.250 Double Click Connect
3 ¹²	Stud 1/4-20	9 ¹⁵	7/16" Clip Terminal
4 ¹¹	Stud M5 x 0.8	A ¹⁴	Plug-In Stud
5 ¹¹	Screw M5 x 0.8	C ^{11,15}	5/16" Clip Terminal

9 ACTUATOR COLOR & LEGEND¹⁶

Actuator Color	I-O	ON-OFF	Dual	Legend Color
White	A	B	1	Black
Black	C	D	2	White
Red	F	G	3	White
Green	H	J	4	White
Blue	K	L	5	White
Yellow	M	N	6	Black
Gray	P	Q	7	Black
Orange	R	S	8	Black
Black (short handle) ¹⁷	T	U	9	White

10 MOUNTING / BARRIERS

MOUNTING STYLE	BARRIERS	VOLTAGE
Threaded Insert		
1	6-32 x 0.195 inches	no < 300
A	6-32 X 0.195 inches	yes < 300
C 18	6-32 X 0.195 inches	yes ≥ 300
2	ISO M3 x 5mm	no < 300
B	ISO M3 x 5mm	yes < 300
D 18	ISO M3 x 5mm	yes ≥ 300
Front panel Snap-In, 1.00" [25.4mm] wide bezel		
E 17	with Handleguard	no < 300

11 AGENCY APPROVAL
C UL Recognized, CSA Accepted
D VDE Certified, UL Recognized, CSA Accepted
E TUV Certified, UL Recognized, CSA Accepted
H UL489 Construction: VDE Certified, UL Recognized, CSA Accepted
I UL Recognized STD 1077, UL Recognized 1500 (ignition protected), CSA Accepted
L UL489 Construction: UL Recognized, CSA Accepted
R UL489 Construction: TUV Certified, UL Recognized, CSA Accepted

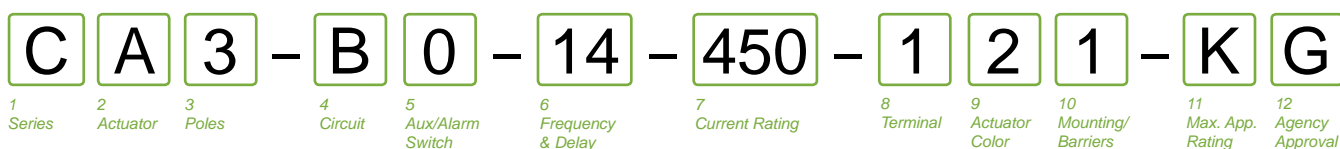

1 SERIES
C

- 2 ACTUATOR ¹**
- A** Handle, one per pole
 - B** Handle, one per multipole unit
 - S** Mid-Trip Handle, one per pole
 - T** Mid-Trip Handle, one per pole & Alarm Switch

- 3 POLES ²**
- 2** Two
 - 3** Three

- 4 CIRCUIT**
- B** Series Trip (Current)

- 5 AUXILIARY / ALARM SWITCH ³**
- 0** without Aux Switch
 - 2** S.P.D.T., 0.110 Q.C. Term.
 - 3** S.P.D.T., 0.139 Solder Lug
 - 4** S.P.D.T., 0.110 Q.C. Term. (Gold Contacts)
 - 6** S.P.S.T., 0.139 Solder Lug
 - 8** S.P.S.T., 0.187 Q.C. Term.
 - 9** S.P.D.T., 0.187 Q.C. Term.

- 6 FREQUENCY & DELAY**
- | | |
|--|---|
| <ul style="list-style-type: none"> 11 DC Ultra Short 12 DC Short 14 DC Medium 16 DC Long 21 50/60Hz Ultra Short 22 50/60Hz Short 24 50/60Hz Medium | <ul style="list-style-type: none"> 26 50/60Hz Long 42 ⁴ 50/60Hz Short, Hi-Inrush 44 ⁴ 50/60Hz Medium, Hi-Inrush 46 ⁴ 50/60Hz Long, Hi-Inrush 52 ⁴ DC Short, Hi-Inrush 54 ⁴ DC Medium, Hi-Inrush 56 ⁴ DC Long, Hi-Inrush |
|--|---|

Notes:

- 1 Actuator Code:
A: Handle tie pin spacer(s) and retainers provided assembled with multi-pole units.
B: Handle located, as viewed from front of breaker in left pole. 2 pole maximum.
S: Handle moves to mid-position only upon electrical trip of the breaker.
T: Handle moves to mid-position and alarm switch activates only upon electrical trip of the breaker.
- 2 Standard multipole units have all poles identical except when specifying auxiliary switch and/or mixed poles.
2 & 3 pole circuit breakers required for 120/240 VAC (Maximum application rating code C) applications, have all poles identical except when specifying auxiliary / alarm switch which is normally supplied in extreme right pole per figure B. Terminal barriers are required on all multipole breakers.
Third pole is for 120/240 VAC applications requiring neutral disconnect. The 3rd pole has the same construction as poles 1 & 2.
- 3 On multi-pole breakers, one auxiliary switch is supplied, mounted in the extreme right pole.
VDE approval on auxiliary switch codes 2, 3 & 4 only.
Auxiliary / Alarm Switch with Independent Circuit ie: separate from breaker circuit, only available with circuit breakers rated 50 amp maximum at 80 VDC, 125 VDC, and 120 VAC. Auxiliary / Alarm Switch with Dependent Circuit ie: same as circuit breaker, is supplied from factory with common terminal of auxiliary / alarm switch connected to line terminal on 120/240 and 240 VAC ratings. Circuit breakers rated 120 VAC 50 amp maximum can be supplied with Auxiliary/Alarm switch common terminal connected to breaker line terminal. Consult factory for special catalog number.
- 4 Available up to 50 amps maximum.
- 5 Current ratings 71 - 100 with VDE approvals are available up to two poles maximum.
- 6 Terminal Codes 9 & C are not VDE approved.
- 7 Terminal Code 1 available to 60 amps maximum.
- 8 Terminal Codes 2, 4, 5 & C available to 50 amps maximum.
- 9 Terminal Codes 3, 6 & 9 available to 100 amps maximum.
- 10 Terminal Code A available to 100 amps maximum.
- 11 VDE and TUV approvals require Dual (I-O, ON-OFF) markings on all handles.
- 12 Barriers supplied on multi-pole units only.

7 CURRENT RATING (AMPERES)

CODE	AMPERES	CODE	AMPERES	CODE	AMPERES	CODE	AMPERES
210	0.100	295	0.950	470	7.000	618	18.000
215	0.150	410	1.000	475	7.500	620	20.000
220	0.200	512	1.250	480	8.000	622	22.000
225	0.250	415	1.500	485	8.500	624	24.000
230	0.300	517	1.750	490	9.000	625	25.000
235	0.350	420	2.000	495	9.500	630	30.000
240	0.400	522	2.250	610	10.000	635	35.000
245	0.450	425	2.500	710	10.500	640	40.000
250	0.500	527	2.750	611	11.000	660	60.000
255	0.550	430	3.000	711	11.500	670	70.000
260	0.600	435	3.500	612	12.000	680	80.000
265	0.650	440	4.000	712	12.500	685	85.000
270	0.700	445	4.500	613	13.000	690	90.000
275	0.750	450	5.000	614	14.000	695	95.000
280	0.800	455	5.500	615	15.000	810	100.000
285	0.850	460	6.000	616	16.000		
290	0.900	465	6.500	617	17.000		

- 8 TERMINAL ⁶**
- | | |
|--------------------------------------|---|
| 1 ⁷ Stud 10-32 | 6 ⁹ Stud M6 |
| 2 ⁸ Screw 10-32 | 9 ⁹ 7/16" Clip Terminal |
| 3 ⁹ Stud 1/4-20 | A ¹⁰ Plug-In Stud |
| 4 ⁸ Stud M5 x 0.8 | C ⁸ 5/16" Clip Terminal |
| 5 ⁸ Screw M5 x 0.8 | |

9 ACTUATOR COLOR & LEGEND ¹¹

Actuator Color	ON-OFF	Dual	Legend Color
White	B	1	Black
Black	D	2	White
Red	G	3	White
Green	J	4	White
Blue	L	5	White
Yellow	N	6	Black
Gray	Q	7	Black
Orange	S	8	Black

10 MOUNTING / BARRIERS

MOUNTING STYLE	BARRIERS ¹²
Threaded Insert	
1 6-32 x 0.195 inches	yes
2 ISO M3 x 5mm	yes

11 MAXIMUM APPLICATION RATING

A 65 DC
B 125 DC
C 120/240 AC ²
D 240 AC
K 120 AC
F 277 AC
M 80 DC

12 AGENCY APPROVAL ¹¹

A without approvals
F UL489 Listed, CSA Certified & VDE Certified
G UL489 Listed & CSA Certified
J UL489 Listed, CSA Certified & TUV Certified

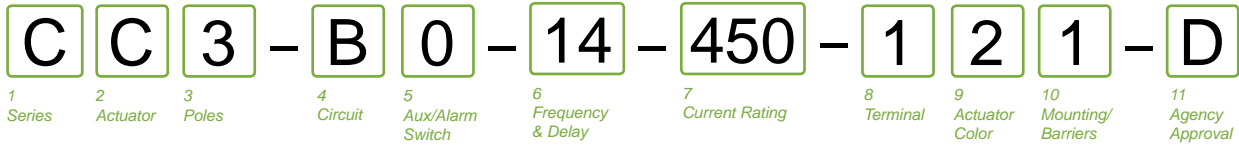

1 SERIES
C

2 ACTUATOR 1

Two Color Visi-Rocker

- C Indicate ON, vertical legend
- D Indicate ON, horizontal legend
- E Indicate ON, no legend
- F Indicate OFF, vertical legend
- G Indicate OFF, horizontal legend
- H Indicate OFF, no legend

Push-To-Reset, Visi-Rocker

- N Indicate OFF, vertical legend
- O Indicate OFF, horizontal legend
- P Indicate OFF, no legend

Single color

- J Vertical legend
- K Horizontal legend
- L No legend

Push-To-Reset, Single color

- R Vertical legend
- U Horizontal legend
- V No legend

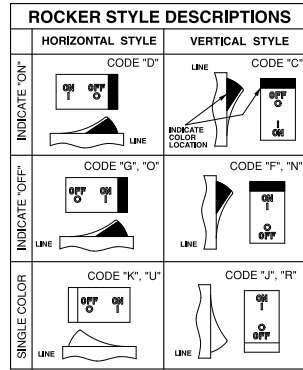

3 POLES 2

- 1 One
- 2 Two
- 3 Three

4 CIRCUIT

- A³ Switch Only (No Coil)
- B Series Trip (Current)
- C Series Trip (Voltage)
- D⁴ Shunt Trip (Current)
- E⁴ Shunt Trip (Voltage)
- F⁴ Relay Trip (Current)
- G⁴ Relay Trip (Voltage)
- H^{4,5} Dual Coil with Shunt Trip Voltage Coil
- K^{4,5} Dual Coil with Relay Trip Voltage Coil

5 AUXILIARY / ALARM SWITCH 6

- 0 without Aux Switch
- 2 S.P.D.T., 0.110 Q.C. Term.
- 3 S.P.D.T., 0.139 Solder Lug
- 4 S.P.D.T., 0.110 Q.C. Term. (Gold Contacts)
- 6 S.P.S.T., 0.139 Solder Lug
- 8 S.P.S.T., 0.187 Q.C. Term.
- 9 S.P.D.T., 0.187 Q.C. Term.

6 FREQUENCY & DELAY

- 03 DC 50/60Hz, Switch Only
- 10⁷ DC Instantaneous
- 11 DC Ultra Short
- 12 DC Short
- 14 DC Medium
- 16 DC Long
- 20⁷ 50/60Hz Instantaneous
- 21 50/60Hz Ultra Short
- 22 50/60Hz Short
- 24 50/60Hz Medium
- 26 50/60Hz Long
- 30 DC 50/60Hz Instantaneous
- 31 DC 50/60Hz Ultra Short
- 32 DC 50/60Hz Short
- 34 DC 50/60Hz Medium
- 36 DC 50/60Hz Long
- 42⁸ 50/60Hz Short, Hi-Inrush
- 44⁸ 50/60Hz Medium, Hi-Inrush
- 46⁸ 50/60Hz Long, Hi-Inrush
- 52⁸ DC Short, Hi-Inrush
- 54⁸ DC Medium, Hi-Inrush
- 56⁸ DC Long, Hi-Inrush

Notes:

- 1 Push-To-Reset actuators have OFF portion of rocker shrouded.
- 2 Multi-pole breakers have all poles identical except when specifying Auxiliary switch and/or mixed poles, and have one rocker per breaker. Rocker location as viewed from front panel: 2 pole – left pole; 3 pole – center pole.
- 3 Switch Only circuits, rated up to 50 amps and 3 poles, and only available with VDE Certification when tied to a protected pole (Circuit Code B, C, D or H.). For 02 to 30 amps, select Current Code 630. For 35 - 50 amps, select Current Code 650. For 55-70 amps, select Current Code 670. For 75-100 amps, select Current Code 810.
- 4 Circuit Codes D, E, F, G, H & K available with Terminal Codes 1, 2, 4 & 5 only. Circuit Codes D, F, H & K available up to 50 amps maximum Current Rating.
- 5 Consult factory for available Dual Coil options, as special catalog number is required. Dual Coil Voltage Coils with Shunt Trip Construction trip instantaneously on line voltage. Dual Coil Voltage Coils require 30VA minimum power to trip instantaneously and are rated for intermittent duty only.
- 6 Auxiliary Switch available with Series Trip and Switch Only circuits. On multi-pole breakers, one auxiliary switch is supplied, mounted in the extreme right pole. Auxiliary switch codes 2, 3 & 4 are VDE approved.
- 7 Voltage coils not rated for continuous duty. Available only with delay codes 10 & 20.
- 8 Available with Circuit Codes B & D only, and up to 50 amps maximum.
- 9 Current Ratings 60-70 are available up to four poles maximum. Ratings 71-100 are available up to two poles maximum.
- 10 Terminal Code 1 available to 60 amps maximum.
- 11 Terminal Codes 2,4,5 & C available to 50 amps maximum.
- 12 Terminal Codes 3,6 & 9 available to 100 amps maximum.
- 13 Terminal Code 7 available to 25 amps maximum.
- 14 Terminal Code A available to 100 amps maximum.
- 15 Terminal Codes 7, 9 & C are not VDE approved.
- 16 Color shown is visi and legend with remainder of rocker black
- 17 Legend on Push-to-reset bezel/shroud is white when single color rocker is ordered. Dual = ON-OFF/I-O legend with actuator codes C - G, and J, K, N, O, R, & U. None = no legend with actuator codes H, L, P, V. Rockerguard available with actuator codes C - L. Push-to-reset available with actuator codes N, O, P, R, U, V.
- 18 VDE/TUV approval requires Dual (I-O, ON-OFF) or I-O markings on rocker.
- 19 VDE/TUV: 30 amps max.; UL/CSA: 50 amps max.; Available in 2 - 4 poles only and limited to AC Delays. "General Purpose amps" not rated for "full load amps" or to be used in applications with a motor.

7 CURRENT RATING (AMPERES)

CODE	AMPERES	CODE	AMPERES	CODE	AMPERES	CODE	AMPERES
020	0.020	235	0.350	430	3.000	614	14.000
025	0.025	240	0.400	435	3.500	615	15.000
030	0.030	245	0.450	440	4.000	616	16.000
035	0.035	250	0.500	445	4.500	617	17.000
040	0.040	255	0.550	450	5.000	618	18.000
045	0.045	260	0.600	455	5.500	620	20.000
050	0.050	265	0.650	460	6.000	622	22.000
055	0.055	270	0.700	465	6.500	624	24.000
060	0.060	275	0.750	470	7.000	625	25.000
065	0.065	280	0.800	475	7.500	630	30.000
070	0.070	285	0.850	480	8.000	635	35.000
075	0.075	290	0.900	485	8.500	640	40.000
080	0.080	295	0.950	490	9.000	650	50.000
085	0.085	410	1.000	495	9.500	660 ⁹	60.000
090	0.090	512	1.250	610	10.000	670 ⁹	70.000
095	0.095	415	1.500	710	10.500	680 ⁹	80.000
210	0.100	517	1.750	611	11.000	685 ⁹	85.000
215	0.150	420	2.000	711	11.500	690 ⁹	90.000
220	0.200	522	2.250	612	12.000	695 ⁹	95.000
225	0.250	425	2.500	712	12.500	810 ⁹	100.000
230	0.300	527	2.750	613	13.000		

OR VOLTAGE COIL (NORMAL RATED VOLTAGE) 7

CODE	AMPERES	CODE	AMPERES	CODE	AMPERES	CODE	AMPERES
A06	6 DC	A32	32 DC	J12	12 AC	J65	65 AC
A12	12 DC	A48	48 DC	J18	18 AC	K20	120 AC
A18	18 DC	A65	65 DC	J24	24 AC	L40	240 AC
A24	24 DC	J06	6 AC	J48	48 AC		

8 TERMINAL

- 1¹⁰ Stud 10-32
- 2¹¹ Screw 10-32
- 3¹² Stud 1/4-20
- 4¹¹ Stud M5 x 0.8
- 5¹¹ Screw M5 x 0.8
- 6¹² Stud M6
- 7¹³ 0.250 Double Quick Connect
- 9 7/16" Clip Terminal
- A¹⁴ Plug-In Stud
- C 5/16" Clip Terminal

9 ACTUATOR COLOR & LEGEND 16,17,18

Actuator or Visi-Color	Marking:	Marking Color:
Color:	I-O ON-OFF	Single Color
White	A B	Black/Handle
Black	C D	White
Red	F G	White
Green	H J	White
Blue	K L	White
Yellow	M N	Black
Gray	P Q	Black
Orange	R S	Black
		Visi-Rocker
		White
		n/a
		Red
		Green
		Blue
		Yellow
		Gray
		Orange

10 MOUNTING / BARRIERS 1

	STANDARD ROCKER BEZEL	BARRIERS	VOLTAGE
1	6-32 x 0.195 inches	no	<300
2	6-32 x 0.195 inches	yes	<300
3 ¹⁹	6-32 x 0.195 inches	yes	≥300
4	ISO M3 x 5mm	no	<300
5	ISO M3 x 5mm	yes	<300
6 ¹⁹	ISO M3 x 5mm	yes	≥300
ROCKERGUARD BEZEL			
A	6-32 x 0.195 inches	no	<300
C	6-32 x 0.195 inches	yes	<300
E ¹⁹	6-32 x 0.195 inches	yes	≥300
G	ISO M3 x 5mm	no	<300
J	ISO M3 x 5mm	yes	<300
L ¹⁹	ISO M3 x 5mm	yes	≥300
PUSH-TO-RESET BEZEL			
B	6-32 x 0.195 inches	no	<300
D	6-32 x 0.195 inches	yes	<300
F ¹⁹	6-32 x 0.195 inches	yes	≥300
H	ISO M3 x 5mm	no	<300
J	ISO M3 x 5mm	yes	<300
M ¹⁹	ISO M3 x 5mm	yes	≥300

11 AGENCY APPROVAL

- C UL Recognized & CSA Accepted
- D VDE Certified, UL Recognized & CSA Accepted
- E TUV Certified, UL Recognized & CSA Accepted
- H UL489 Construction: VDE Certified, UL Recognized & CSA Accepted
- I UL Recognized STD 1077, UL Recognized 1500 (ignition protected), & CSA Accepted
- L UL489 Construction: UL Recognized & CSA Accepted
- R UL489 Construction: TUV Certified, UL Recognized & CSA Accepted

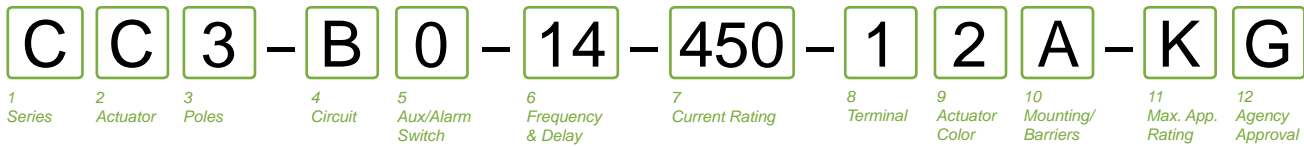

1 SERIES
C

2 ACTUATOR 1
Two Color Visi-Rocker
C Indicate ON, vertical legend
D Indicate ON, horizontal legend
F Indicate OFF, vertical legend
G Indicate OFF, horizontal legend
Single color
J Vertical legend
K Horizontal legend

ROCKER STYLE DESCRIPTIONS

VERTICAL STYLE	INDICATE "ON" CODE "C" 	INDICATE "OFF" CODE "F" 	SINGLE COLOR CODE "J"
	INDICATE COLOR LOCATION 		
HORIZONTAL STYLE	CODE "D" 	CODE "G" 	CODE "K"

3 POLES 1
1 One 2 Two 3 Three

4 CIRCUIT
B Series Trip (current)

5 AUXILIARY / ALARM SWITCH 2

0 without Aux Switch	6 S.P.D.T., 0.139 Solder Lug
2 S.P.D.T., 0.110 Q.C. Term.	8 S.P.S.T., 0.187 Q.C. Term.
3 S.P.D.T., 0.139 Solder Lug	9 S.P.D.T., 0.187 Q.C. Term.
4 S.P.D.T., 0.110 Q.C. Term. (Gold Contacts)	

6 FREQUENCY & DELAY

11 DC Ultra Short	42 ⁸ 50/60Hz Short, Hi-Inrush
12 DC Short	44 ⁸ 50/60Hz Medium, Hi-Inrush
14 DC Medium	46 ⁸ 50/60Hz Long, Hi-Inrush
16 DC Long	52 ⁸ DC Short, Hi-Inrush
21 50/60Hz Ultra Short	54 ⁸ DC Medium, Hi-Inrush
22 50/60Hz Short	56 DC Long, Hi-Inrush
24 50/60Hz Medium	
26 50/60Hz Long	

Notes:

- Multi-pole breakers have all breakers identical except when specifying Auxiliary switch and/or mixed poles, and have one rocker per breaker.
- On multi-pole breakers, one auxiliary switch is supplied, mounted in the extreme right pole.
- Available up to 50 amps maximum.
- Current ratings 71 - 100 with VDE approvals are available up to two poles maximum.
- Terminal Code 1 available to 60 amps maximum.
- Terminal Codes 2, 4, 5 & C available to 50 amps maximum.
- Terminal Codes 3, 6, 9 & A available to 100 amps maximum.
- Terminal Codes 9 & C are not VDE approved.
- Color shown is visi and legend with remainder of rocker black
- Dual = ON-OFF/I-O legend on actuator.
- VDE and TUV approval requires Dual (I-O, ON-OFF) markings on rocker.
- Rockerguard available with all actuator codes.
- Barriers supplied on multi-pole units only.
- 2 & 3 pole circuit breakers required for 120/240 AC rating.

7 CURRENT RATING (AMPERES) 4

CODE	AMPERES	CODE	AMPERES	CODE	AMPERES	CODE	AMPERES
210	0.100	295	0.950	470	7.000	618	18.000
215	0.150	410	1.000	475	7.500	620	20.000
220	0.200	512	1.250	480	8.000	622	22.000
225	0.250	415	1.500	485	8.500	624	24.000
230	0.300	517	1.750	490	9.000	625	25.000
235	0.350	420	2.000	495	9.500	630	30.000
240	0.400	522	2.250	610	10.000	635	35.000
245	0.450	425	2.500	710	10.500	640	40.000
250	0.500	527	2.750	611	11.000	650	50.000
255	0.550	430	3.000	711	11.500	660	60.000
260	0.600	435	3.500	612	12.000	670	70.000
265	0.650	440	4.000	712	12.500	680	80.000
270	0.700	445	4.500	613	13.000	685	85.000
275	0.750	450	5.000	614	14.000	690	90.000
280	0.800	455	5.500	615	15.000	695	95.000
285	0.850	460	6.000	616	16.000	810	100.00
290	0.900	465	6.500	617	17.000		

8 TERMINAL

1 ⁵ Stud 10-32	6 ⁷ Stud M6
2 ⁶ Screw 10-32 with saddle & washer clamps	9 ^{7,8} 7/16" Clip Terminal
3 ⁷ Stud 1/4-20	A ^{7,8} Plug-In Stud
4 ⁶ Stud M5 x 0.8	C ^{6,8} 5/16" Clip Terminal
5 ⁶ Screw M5 x 0.8 with saddle & washer clamps	

9 ACTUATOR COLOR & LEGEND 11

Actuator or Visi-Color	Marking:	Marking Color:	Single Color	Rocker/Handle	Visi-Rocker
White	B	1	Black	White	White
Black	D	2	White	n/a	n/a
Red	G	3	White	Red	Red
Green	J	4	White	Green	Green
Blue	L	5	White	Blue	Blue
Yellow	N	6	Black	Yellow	Yellow
Gray	Q	7	Black	Gray	Gray
Orange	S	8	Black	Orange	Orange

10 MOUNTING / BARRIERS 12

	Standard Rocker Bezel Threaded Insert, 2 per pole	Rockerguard Bezel Threaded Insert, 2 per pole	BARRIERS 13
A	6-32 X 0.195 inches	yes	
C	ISO M3 x 5mm	yes	
B	6-32 x 0.195 inches	yes	
D	ISO M3 x 5mm	yes	

11 MAXIMUM APPLICATION RATING

A	65 DC
B	125 DC
C	120/240 AC 14
D	240 AC
F	277 AC
K	120 AC
M	80 DC

12 AGENCY APPROVAL

A	without approvals
F	UL 489 Listed, CSA Certified, & VDE Certified
G	UL 489 Listed & CSA Certified
J	UL489 Listed, CSA Certified & TUV Certified

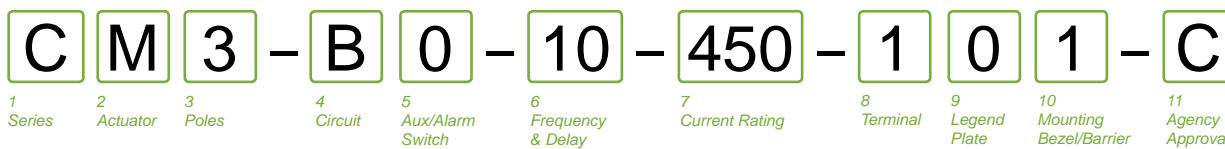

1 SERIES
C

2 ACTUATOR 1
M Sealed Toggle, one per pole

3 POLES
1 One 2 Two 3 Three

4 CIRCUIT
A² Switch Only (no coil)
B Series Trip (current)
C Series Trip (voltage)
D³ Shunt Trip (current)
E³ Shunt Trip (voltage)

F³ Relay Trip (current)
G³ Relay Trip (voltage)
H^{3,4} Dual Coil with Shunt Trip Voltage Coil
K^{3,4} Dual Coil with Relay Trip Voltage Coil

5 AUXILIARY / ALARM SWITCH
0 without Aux Switch
2 S.P.D.T., 0.110 Q.C. Term.
3 S.P.D.T., 0.139 Solder Lug
4 S.P.D.T., 0.110 Q.C. Term. (Gold Contacts)

6 S.P.S.T., 0.139 Solder Lug
8 S.P.S.T., 0.187 Q.C. Term.
9 S.P.D.T., 0.187 Q.C. Term.

6 FREQUENCY & DELAY
03² DC 50/60Hz, Switch Only
10⁶ DC Instantaneous
11 DC Ultra Short
12 DC Short
14 DC Medium
16 DC Long
20⁶ 50/60Hz Instantaneous
21 50/60Hz Ultra Short
22 50/60Hz Short
24 50/60Hz Medium
26 50/60Hz Long

30 DC 50/60Hz Instantaneous
31 DC 50/60Hz Ultra Short
32 DC 50/60Hz Short
34 DC 50/60Hz Medium
36 DC 50/60Hz Long
42⁷ 50/60Hz Short, Hi-Inrush
44⁷ 50/60Hz Medium, Hi-Inrush
46⁷ 50/60Hz Long, Hi-Inrush
52⁷ DC Short, Hi-Inrush
54⁷ DC Medium, Hi-Inrush
56 DC Long, Hi-Inrush

Notes:

- 1 Actuator Code M: Handle location as viewed from front of breaker:
2 pole - right pole 3 pole - center pole
- 2 Switch Only circuits, rated up to 50 amps and 3 poles, and only available with VDE. For .02 to 30 amps, select Current Code 630. For 35 - 50 amps, select Current Code 650. For 55-70 amps, select Current Code 670. For 75-100 amps, select Current Code 810.
- 3 Circuit Codes D,E,F,G,H & K available with Terminal Codes 1,2,4 & 5 only.
- 4 Consult factory for available Dual Coil options, as special catalog number is required. Dual Coil Voltage Coils with Shunt Trip Construction trip instantaneously on line voltage. Dual Coil Voltage Coils require 30VA minimum power to trip instantaneously and are rated for intermittent duty only.
- 5 Auxiliary Switch available with Series Trip and Switch Only circuits. On multi-pole breakers, one auxiliary switch is supplied, mounted in the extreme right pole.
- 6 Voltage coils not rated for continuous duty. Available only with delay codes 10 & 20.
- 7 Available with Circuit Codes B & D only, and up to 50 amps maximum.
- 8 Consult factory for current ratings 71-100, in three pole units, available as special catalog number only.
- 9 Terminal Code 1 available to 60 amps maximum.
- 10 Terminal Codes 2, 4, 5 and C available to 50 amps maximum.
- 11 Terminal Codes 3, 6 & 9 available to 100 amps maximum.
- 12 Terminal Code 7 available to 25 amps maximum.
- 13 Terminal Code A available to 100 amps maximum.

7 CURRENT RATING (AMPERES) 9

CODE	AMPERES	CODE	AMPERES	CODE	AMPERES	CODE	AMPERES
020	0.020	235	0.350	430	3.000	614	14.000
025	0.025	240	0.400	435	3.500	615	15.000
030	0.030	245	0.450	440	4.000	616	16.000
035	0.035	250	0.500	445	4.500	617	17.000
040	0.040	255	0.550	450	5.000	618	18.000
045	0.045	260	0.600	455	5.500	620	20.000
050	0.050	265	0.650	460	6.000	622	22.000
055	0.055	270	0.700	465	6.500	624	24.000
060	0.060	275	0.750	470	7.000	625	25.000
065	0.065	280	0.800	475	7.500	630	30.000
070	0.070	285	0.850	480	8.000	635	35.000
075	0.075	290	0.900	485	8.500	640	40.000
080	0.080	295	0.950	490	9.000	650	50.000
085	0.085	410	1.000	495	9.500	660 ⁹	60.000
090	0.090	512	1.250	610	10.000	670 ⁹	70.000
095	0.095	415	1.500	710	10.500	680 ⁹	80.000
210	0.100	517	1.750	611	11.000	685 ⁹	85.000
215	0.150	420	2.000	711	11.500	690 ⁹	90.000
220	0.200	522	2.250	612	12.000	695 ⁹	95.000
225	0.250	425	2.500	712	12.500	810 ⁹	100.00
230	0.300	527	2.750	613	13.000		

OR VOLTAGE COIL (NORMAL RATED VOLTAGE) 7

CODE	AMPERES	CODE	AMPERES	CODE	AMPERES		
A06	6 DC	A32	32 DC	J12	12 AC	J65	65 AC
A12	12 DC	A48	48 DC	J18	18 AC	K20	120 AC
A18	18 DC	A65	65 DC	J24	24 AC	L40	240 AC
A24	24 DC	J06	6 AC	J48	48 AC		

8 TERMINAL

1 ⁹	Stud 10-32	6 ¹¹	Stud M6
2 ¹⁰	Screw 10-32	7 ¹²	0.250 Double Click Connect
3 ¹¹	Stud 1/4-20	9 ¹¹	7/16" Clip Terminal
4 ¹⁰	Stud M5 x 0.8	A ¹³	Plug-In Stud
5 ¹⁰	Screw M5 x 0.8	C ¹⁰	5/16" Clip Terminal

9 LEGEND PLATE
0 No Legend

10 MOUNTING / BARRIERS

MOUNTING STYLE	BARRIERS	
1	Standard Hex Nut	no
A	Standard Hex Nut (multi-pole units only)	yes

11 AGENCY APPROVAL
C UL Recognized & CSA Accepted
I UL Recognized & CSA Accepted, UL1500 ignition protection
L UL Recognized & CSA Accepted with listed construction

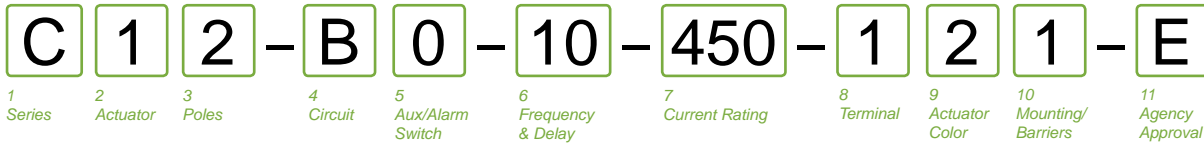

1 SERIES
C

2 ACTUATOR 1

Two Color Visi-Rocker

- 1 Indicate OFF, vertical legend
- 2 Indicate OFF, horizontal legend

Single color

- 3 Vertical legend
- 4 Horizontal legend

Push-To-Reset, Visi-Rocker

- 5 Indicate OFF, vertical legend
- 6 Indicate OFF, horizontal legend

Push-To-Reset, Single color

- 7 Vertical legend
- 8 Horizontal legend

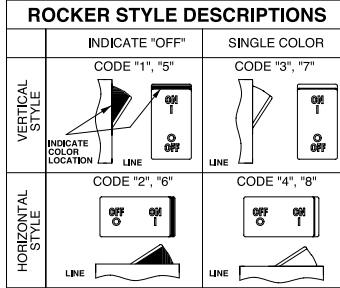

3 POLES 2

- 1 One
- 2 Two
- 3 Three

4 CIRCUIT

- A³ Switch Only (No Coil)
- B Series Trip (Current)
- C Series Trip (Voltage)
- D⁴ Shunt Trip (Current)
- E⁴ Shunt Trip (Voltage)
- F⁴ Relay Trip (Current)
- G⁴ Relay Trip (Voltage)
- H^{4,5} Dual Coil with Shunt Trip Voltage Coil
- K^{4,5} Dual Coil with Relay Trip Voltage Coil

5 AUXILIARY / ALARM SWITCH 6

- 0 without Aux Switch
- 2 S.P.D.T., 0.110 Q.C. Term.
- 3 S.P.D.T., 0.139 Solder Lug
- 4 S.P.D.T., 0.110 Q.C. Term. (Gold Contacts)
- 6 S.P.S.T., 0.139 Solder Lug
- 8 S.P.S.T., 0.187 Q.C. Term.
- 9 S.P.D.T., 0.187 Q.C. Term.

6 FREQUENCY & DELAY

- 03 DC 50/60Hz, Switch Only
- 10 7 DC Instantaneous
- 11 DC Ultra Short
- 12 DC Short
- 14 DC Medium
- 16 DC Long
- 20 7 50/60Hz Instantaneous
- 21 50/60Hz Ultra Short
- 22 50/60Hz Short
- 24 50/60Hz Medium
- 26 50/60Hz Long
- 30 DC 50/60Hz Instantaneous
- 31 DC 50/60Hz Ultra Short
- 32 DC 50/60Hz Short
- 34 DC 50/60Hz Medium
- 36 DC 50/60Hz Long
- 42⁸ 50/60Hz Short, Hi-Inrush
- 44⁸ 50/60Hz Medium, Hi-Inrush
- 46⁸ 50/60Hz Long, Hi-Inrush
- 52⁸ DC Short, Hi-Inrush
- 54⁸ DC Medium, Hi-Inrush
- 56⁸ DC Long, Hi-Inrush

Notes:

- 1 Push-to-reset actuators have OFF portion of rocker shrouded.
- 2 Multi-pole breakers have all poles identical except when specifying Auxiliary switch and/or mixed poles, and have one rocker per breaker. Rocker location as viewed from front panel: 2 pole – left pole; 3 pole – center pole.
- 3 Switch Only circuits, rated up to 50 amps and 3 poles, and only available with VDE Certification when tied to a protected pole (Circuit Code B, C, D or H.). For .02 to 30 amps, select Current Code 630. For 35 - 50 amps, select Current Code 650. For 55-70 amps, select Current Code 670. For 75-100 amps, select Current Code 810.
- 4 Circuit Codes D,E,F,G,H & K available with Terminal Codes 1,2,4 & 5 only. Circuit Codes D,F,H & K available up to 50 amps maximum Current Rating.
- 5 Consult factory for available Dual Coil options, as special catalog number is required. Dual Coil Voltage Coils with Shunt Trip Construction trip instantaneously on line voltage. Dual Coil Voltage Coils require 30VA minimum power to trip instantaneously and are rated for intermittent duty only.
- 6 Auxiliary Switch available with Series Trip and Switch Only circuits. On multi-pole breakers, one auxiliary switch is supplied, mounted in the extreme right pole. Auxiliary switch codes 2, 3 & 4 are VDE approved.
- 7 Voltage coils not rated for continuous duty. Available only with delay codes 10 and 20.
- 8 Available with Circuit Codes B & D only, and up to 50 amps maximum.
- 9 Current ratings 60-70 are available up to four poles maximum. Current ratings 71 - 100 are available up to two poles maximum.
- 10 Terminal Code 1 available to 60 amps maximum.
- 11 Terminal Codes 2,4,5 & C available to 50 amps maximum.
- 12 Terminal Codes 3,6 & 9 available to 100 amps maximum.
- 13 Terminal Code 7 available to 25 amps maximum.
- 14 Terminal Code A available to 100 amps maximum.
- 15 Terminal Codes 7, 9 & C are not VDE approved.
- 16 Color shown is visi & legend with remainder of rocker black. Dual = ON-OFF/I-O legend.
- 17 Legend on Push-to-reset bezel/shroud is white with single color actuator codes 7 & 8. Legend on Push-to-reset bezel/shroud matches visi-color of rocker with actuator codes 5 & 6.
- 18 VDE/TUV approval requires Dual (I-O, ON-OFF) or I-O markings on rocker.
- 19 VDE/TUV: 30 amps max.; UL/CSA: 50 amps max.; Available in 2 & 3 poles only and limited to AC Delays. "General Purpose amps" not rated for "full load amps" or to be used in applications with a motor.
- 20 Recessed "OFF SIDE" available with actuator codes 1,2,3&4. Legends on rocker are available in ink stamping only.

7 CURRENT RATING (AMPERES) 9

CODE	AMPERES	235	0.350	430	3.000	614	14.000
020	0.020	240	0.400	435	3.500	615	15.000
025	0.025	245	0.450	440	4.000	616	16.000
030	0.030	250	0.500	445	4.500	617	17.000
035	0.035	255	0.550	450	5.000	618	18.000
040	0.040	260	0.600	455	5.500	620	20.000
045	0.045	265	0.650	460	6.000	622	22.000
050	0.050	270	0.700	465	6.500	624	24.000
055	0.055	275	0.750	470	7.000	625	25.000
060	0.060	280	0.800	475	7.500	630	30.000
065	0.065	285	0.850	480	8.000	635	35.000
070	0.070	290	0.900	485	8.500	640	40.000
075	0.075	295	0.950	490	9.000	650	50.000
080	0.080	410	1.000	495	9.500	660 ⁹	60.000
085	0.085	512	1.250	610	10.000	670 ⁹	70.000
090	0.090	415	1.500	710	10.500	680 ⁹	80.000
095	0.095	517	1.750	611	11.000	685 ⁹	85.000
210	0.100	420	2.000	711	11.500	690 ⁹	90.000
215	0.150	522	2.250	612	12.000	695 ⁹	95.000
220	0.200	425	2.500	712	12.500	810 ⁹	100.00
225	0.250	527	2.750	613	13.000		
230	0.300						

OR VOLTAGE COIL (NORMAL RATED VOLTAGE) 7

CODE	AMPERES	A32	32 DC	J12	12 AC	J65	65 AC
A06	6 DC	A48	48 DC	J18	18 AC	K20	120 AC
A12	12 DC	A65	65 DC	J24	24 AC	L40	240 AC
A18	18 DC	J06	6 AC	J48	48 AC		
A24	24 DC						

8 TERMINAL

- 1¹⁰ Stud 10-32
- 2¹¹ Screw 10-32
- 3¹² Stud 1/4-20
- 4¹¹ Stud M5 x 0.8
- 5¹¹ Screw M5 x 0.8
- 6¹² Stud M6
- 7¹³ 0.250 Double Quick Connect
- 9¹⁵ 7/16" Clip Terminal
- A¹⁴ Plug-In Stud
- C¹⁵ 5/16" Clip Terminal

9 ACTUATOR COLOR & LEGEND 16,17,18

Actuator or

Visi-Color	Marking:	Marking Color:	Single Color	Visi-Rocker
Color:	I-O ON-OFF	Dual/None	Rocker/Handle	Visi-Rocker
White	A B	1	Black	White
Black	C D	2	White	n/a
Red	F G	3	White	Red
Green	H J	4	White	Green
Blue	K L	5	White	Blue
Yellow	M N	6	Black	Yellow
Gray	P Q	7	Black	Gray
Orange	R S	8	Black	Orange

10 MOUNTING / BARRIERS 1

	STANDARD ROCKER BEZEL	BARRIERS	VOLTAGE
1	6-32 x 0.195 inches	no	<300
2	6-32 x 0.195 inches	yes	<300
3 ¹⁹	6-32 x 0.195 inches	yes	≥300
4	ISO M3 x 5mm	no	<300
5	ISO M3 x 5mm	yes	<300
6 ¹⁹	ISO M3 x 5mm	yes	≥300
RECESSED OFF ROCKER			
7	6-32 x 0.195 inches	no	<300
8	6-32 x 0.195 inches	yes	<300
9	6-32 x 0.195 inches	yes	≥300
A	ISO M3 x 5mm	no	<300
C	ISO M3 x 5mm	yes	<300
E	ISO M3 x 5mm	yes	≥300
PUSH-TO-RESET BEZEL			
B	6-32 x 0.195 inches	no	<300
D	6-32 x 0.195 inches	yes	<300
F ¹⁹	6-32 x 0.195 inches	yes	≥300
H	ISO M3 x 5mm	no	<300
J	ISO M3 x 5mm	yes	<300
M ¹⁹	ISO M3 x 5mm	yes	≥300

11 AGENCY APPROVAL

- C UL Recognized & CSA Accepted
- E TUV Certified, UL Recognized & CSA Accepted
- I UL Recognized STD 1077, UL Recognized 1500 (ignition protected), & CSA Accepted
- L UL489 Construction: UL Recognized & CSA Accepted
- R UL489 Construction: TUV Certified, UL Recognized & CSA Accepted

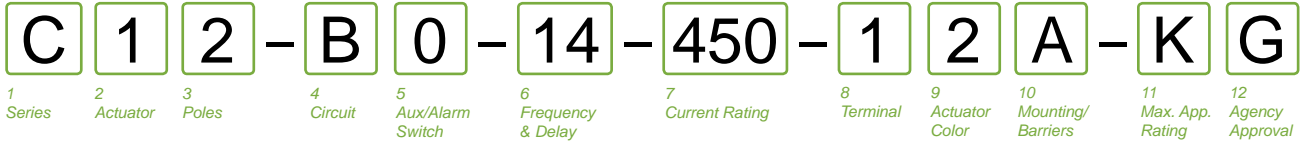

1 SERIES
C

2 ACTUATOR ¹

Two Color Visi-Rocker

- 1 Indicate OFF, vertical legend
- 2 Indicate OFF, horizontal legend
- 3 Vertical legend
- 4 Horizontal legend

Push-To-Reset, Visi-Rocker

- 5 Indicate OFF, vertical legend
- 6 Indicate OFF, horizontal legend
- 7 Vertical legend
- 8 Horizontal legend

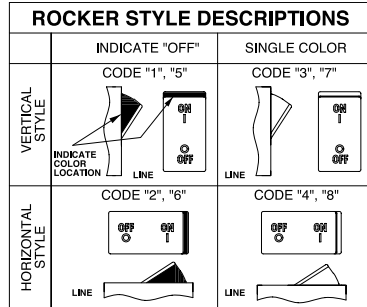

3 POLES ²

- 1 One
- 2 Two
- 3 Three

4 CIRCUIT

- B Series Trip (current)

5 AUXILIARY / ALARM SWITCH ³

- 0 without Aux Switch
- 2 S.P.D.T., 0.110 Q.C. Term.
- 3 S.P.D.T., 0.139 Solder Lug
- 4 S.P.D.T., 0.110 Q.C. Term. (Gold Contacts)
- 6 S.P.S.T., 0.139 Solder Lug
- 8 S.P.S.T., 0.187 Q.C. Term.
- 9 S.P.D.T., 0.187 Q.C. Term.

6 FREQUENCY & DELAY

- 11 DC Ultra Short
- 12 DC Short
- 14 DC Medium
- 16 DC Long
- 21 50/60Hz Ultra Short
- 22 50/60Hz Short
- 24 50/60Hz Medium
- 26 50/60Hz Long
- 42 ⁴ 50/60Hz Short, Hi-Inrush
- 44 ⁴ 50/60Hz Medium, Hi-Inrush
- 46 ⁴ 50/60Hz Long, Hi-Inrush
- 52 ⁴ DC Short, Hi-Inrush
- 54 ⁴ DC Medium, Hi-Inrush
- 56 ⁴ DC Long, Hi-Inrush

Notes:

- 1 Push-to-reset actuators have OFF portion of rocker shrouded.
- 2 Multi-pole breakers have all breakers identical except when specifying Auxiliary switch and/or mixed poles, and have one rocker per breaker.
- 3 On multi-pole breakers, one auxiliary switch is supplied, mounted in the extreme right pole.
- 4 Available up to 50 amps maximum.
- 5 Current ratings 71 - 100 with VDE approvals are available up to two poles maximum.
- 6 Terminal Code 1 available to 60 amps maximum.
- 7 Terminal Codes 2, 4, 5 & C available to 50 amps maximum.
- 8 Terminal Codes 3, 6, 9 & A available to 100 amps maximum.
- 9 Terminal Codes 9 & C are not VDE approved.
- 10 Color shown is visi and legend with remainder of rocker black
- 11 Dual = ON-OFF/I-O legend on actuator.
- 12 TUV approval requires Dual (I-O, ON-OFF) markings on rocker.
- 13 Legend on push-to-reset bezel/shroud is white when single color rocker is ordered. Legend on push-to-reset bezel/shroud matches visi-color of rocker with actuator codes 5 & 6.
- 14 Recessed "OFF-SIDE" available with actuator codes 1, 2, 3, & 4. Legends on rocker are available in ink stamping only.
- 15 Barriers supplied on multi-pole units only.
- 16 2 & 3 pole circuit breakers required for 120/240 AC rating.

7 CURRENT RATING (AMPERES) ⁵

CODE	AMPERES	CODE	AMPERES	CODE	AMPERES	CODE	AMPERES
210	0.100	295	0.950	470	7.000	618	18.000
215	0.150	410	1.000	475	7.500	620	20.000
220	0.200	512	1.250	480	8.000	622	22.000
225	0.250	415	1.500	485	8.500	624	24.000
230	0.300	517	1.750	490	9.000	625	25.000
235	0.350	420	2.000	495	9.500	630	30.000
240	0.400	522	2.250	610	10.000	635	35.000
245	0.450	425	2.500	710	10.500	640	40.000
250	0.500	527	2.750	611	11.000	650	50.000
255	0.550	430	3.000	711	11.500	660	60.000
260	0.600	435	3.500	612	12.000	670	70.000
265	0.650	440	4.000	712	12.500	680	80.000
270	0.700	445	4.500	613	13.000	685	85.000
275	0.750	450	5.000	614	14.000	690	90.000
280	0.800	455	5.500	615	15.000	695	95.000
285	0.850	460	6.000	616	16.000	810	100.00
290	0.900	465	6.500	617	17.000		

8 TERMINAL

- 1 ⁶ Stud 10-32
- 2 ⁷ Screw 10-32
- 3 ⁸ Stud 1/4-20
- 4 ⁷ Stud M5 x 0.8
- 5 ⁷ Screw M5 x 0.8
- 6 ⁸ Stud M6
- 9 ^{8,9} 7/16" Clip Terminal
- A ⁸ Plug-In Stud
- C ^{7,9} 5/16" Clip Terminal

9 ACTUATOR COLOR & LEGEND ¹⁰

Actuator or Visi-Color	Marking:	Marking Color:	Single Color	Visi-Rocker
Color:	ON-OFF	Dual ^{11,12}	Rocker/Handle	
White	B	1	Black	White
Black	D	2	White	n/a
Red	G	3	White	Red
Green	J	4	White	Green
Blue	L	5	White	Blue
Yellow	N	6	Black	Yellow
Gray	Q	7	Black	Gray
Orange	S	8	Black	Orange

10 MOUNTING / BARRIERS

	STANDARD ROCKER BEZEL Threaded Insert, 2 per pole	BARRIERS ¹⁵
A	6-32 X 0.195 inches	yes
C	ISO M3 x 5mm	yes
	RECESSED OFF ROCKER ¹⁴ Threaded Insert, 2 per pole	
E	6-32 x 0.195 inches	yes
F	ISO M3 x 5mm	yes
	PUSH-TO-RESET BEZEL ¹³ Threaded Insert, 2 per pole	
B	6-32 x 0.195 inches	yes
D	ISO M3 x 5mm	yes

11 MAXIMUM APPLICATION RATING

- A 65 DC
- B 125 DC
- C 120/240 AC ¹⁶
- D 240 AC
- F 277 AC
- K 120 AC
- M 80 DC

12 AGENCY APPROVAL ¹²

- A without approvals
- G UL 489 Listed & CSA Certified
- J UL489 Listed, CSA Certified & TUV Certified

Circuit & Terminal Diagrams: in. [mm]

DESCRIPTION	CODE	DIMENSIONAL DETAIL	RATING (AMPS)		
			25	50	100
#10-32 STUD	1				
M5 STUD	4				
#1/4-20 STUD	3				
M6 STUD	6				
#1/4-20 STUD	3				
M6 STUD	6				
#10-32 SCREW	2				
M-5 SCREW	5				

DESCRIPTION	CODE	DIMENSIONAL DETAIL	RATING (AMPS)		
			25	50	100
.250 DOUBLE Q.C.	7				
7/16" CLIP TERMINALS	9				
PUSH-IN STUD	A				

NOTES: TOLERANCE ON STUD LENGTHS IS ±.031 [±.79] UNLESS OTHERWISE SPECIFIED.

AUXILIARY / ALARM SWITCH TERMINAL DETAIL³

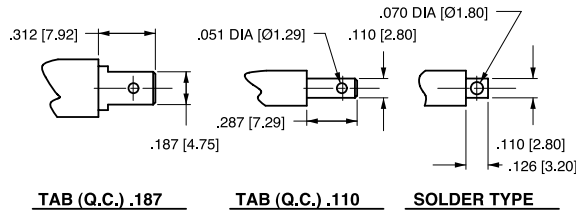

TIGHTENING TORQUE SPECIFICATIONS	
THREAD SIZE	TORQUE
#6-32 [M3] MOUNTING INSERTS	7-9 IN-LBS [0.8-1.0 NM]
#10-32 & M5 THD STUDS	15-20 IN-LBS [1.7-2.3 NM]
#10-32 THD SCREW	15-20 IN-LBS [1.7-2.3 NM]
#1/4-20 & M6 THD STUDS	30-35 IN-LBS [3.4-4.0 NM]

TERMINAL HARDWARE				
TERMINAL DESCRIPTION	CODE	AGENCY APPROVAL	AMPERE RATING	HARDWARE SUPPLIED
#10-32 STUD	1	ALL	.02 - 50	LOCK WASHER - FLAT WASHER - NUT
M5 STUD	4	ALL	.02 - 50	LOCK WASHER - FLAT WASHER - NUT
#1/4-20 STUD	3	ALL	.02 - 80	LOCK WASHER - FLAT WASHER - NUT
			81 - 100	LOCK WASHER - NUT - (2)FLAT WASHER - NUT
M6 STUD	6	ALL	.02 - 80	LOCK WASHER - FLAT WASHER - NUT
			81 - 100	LOCK WASHER - NUT - (2)FLAT WASHER - NUT
#10-32 SCREW	2 & 5	UL RECOGNIZED	.02 - 50	* SADDLE CLAMP - FLAT WASHER - SCREW
		UL-489 LISTED	.02 - 50	LOCK WASHER - FLAT WASHER - SCREW
		TUV & VDE CERTIFIED	.02 - 16	* SADDLE CLAMP - FLAT WASHER - SCREW
		TUV & VDE CERTIFIED	16.1 - 50	LOCK WASHER - FLAT WASHER - SCREW

* THE SADDLE CLAMP IS FOR DIRECT WIRE CONNECTION USE. DISCARD SADDLE CLAMP IF WIRE TERMINAL LUG IS USED

Notes:

- All dimensions are in inches [millimeters].
- Tolerance ±.020 [.51] unless otherwise specified.
- Available on Series Trip and Switch Only Circuits when called for on multi-pole units. Only one auxiliary switch is normally supplied, as viewed in multi-pole identification scheme.

Circuit & Terminal Diagrams: in. [mm]

	CIRCUIT SCHEMATIC		CIRCUIT CODE	AUX SWITCH CODE	CIRCUIT SCHEMATIC		CIRCUIT CODE	AUX SWITCH CODE
	ANSI	IEC			ANSI	IEC		
	SWITCH ONLY (NO COIL)							
			A	O			B	O
	SWITCH ONLY (NO COIL) WITH AUXILIARY SWITCH		A	2 3 4	SERIES TRIP WITH AUXILIARY / ALARM SWITCH		B	C 3 4
	SHUNT TRIP		D E	0	DUAL COIL; SERIES TRIP CURRENT COIL, SHUNT TRIP VOLTAGE COIL		H	0
	RELAY TRIP		F G	0	DUAL COIL; SERIES TRIP CURRENT COIL, RELAY TRIP VOLTAGE COIL		K	0

HANDLE POSITION VS. AUX/ALARM SWITCH MODE					
CIRCUIT BREAKER MODE	STANDARD C/B		MID TRIP C/B		
	HANDLE POSITION	AUX. SWITCH MODE	HANDLE POSITION	STANDARD ALARM SWITCH MODE	REVERSE ALARM SWITCH MODE ⁴
OFF					
ON					
ELECTRICAL TRIP					

Notes:

- 1 All dimensions are in inches [millimeters].
- 2 Tolerance $\pm .020$ [.51] unless otherwise specified.
- 3 Schematic shown represents current trip circuits.
- 4 Available only as special catalog number.

Dimensional Specifications: in. [mm]

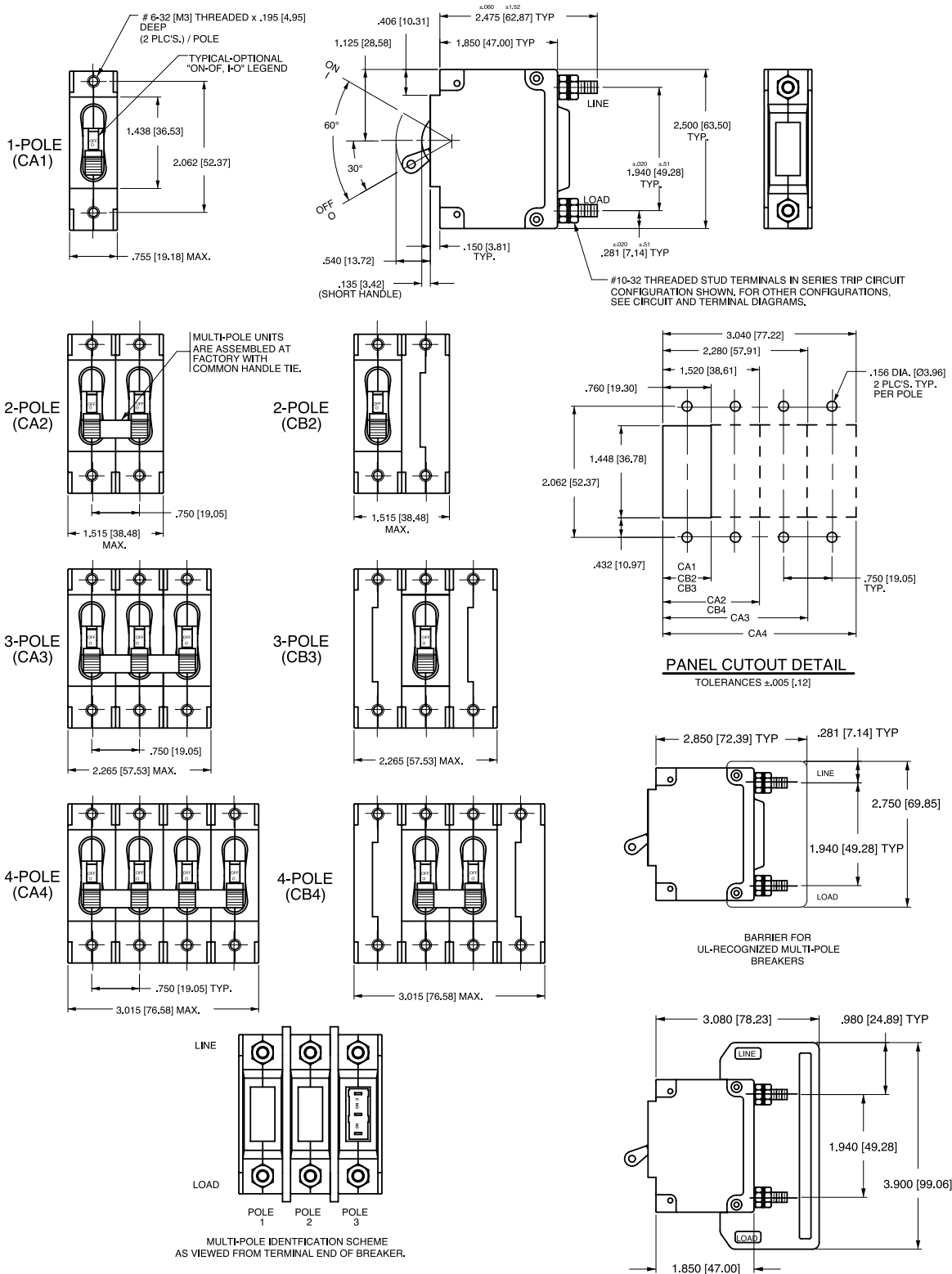

- Notes:
- All dimensions are in inches [millimeters].
 - Tolerance ±.020 [0.51] unless otherwise specified.

Dimensional Specifications: in. [mm]

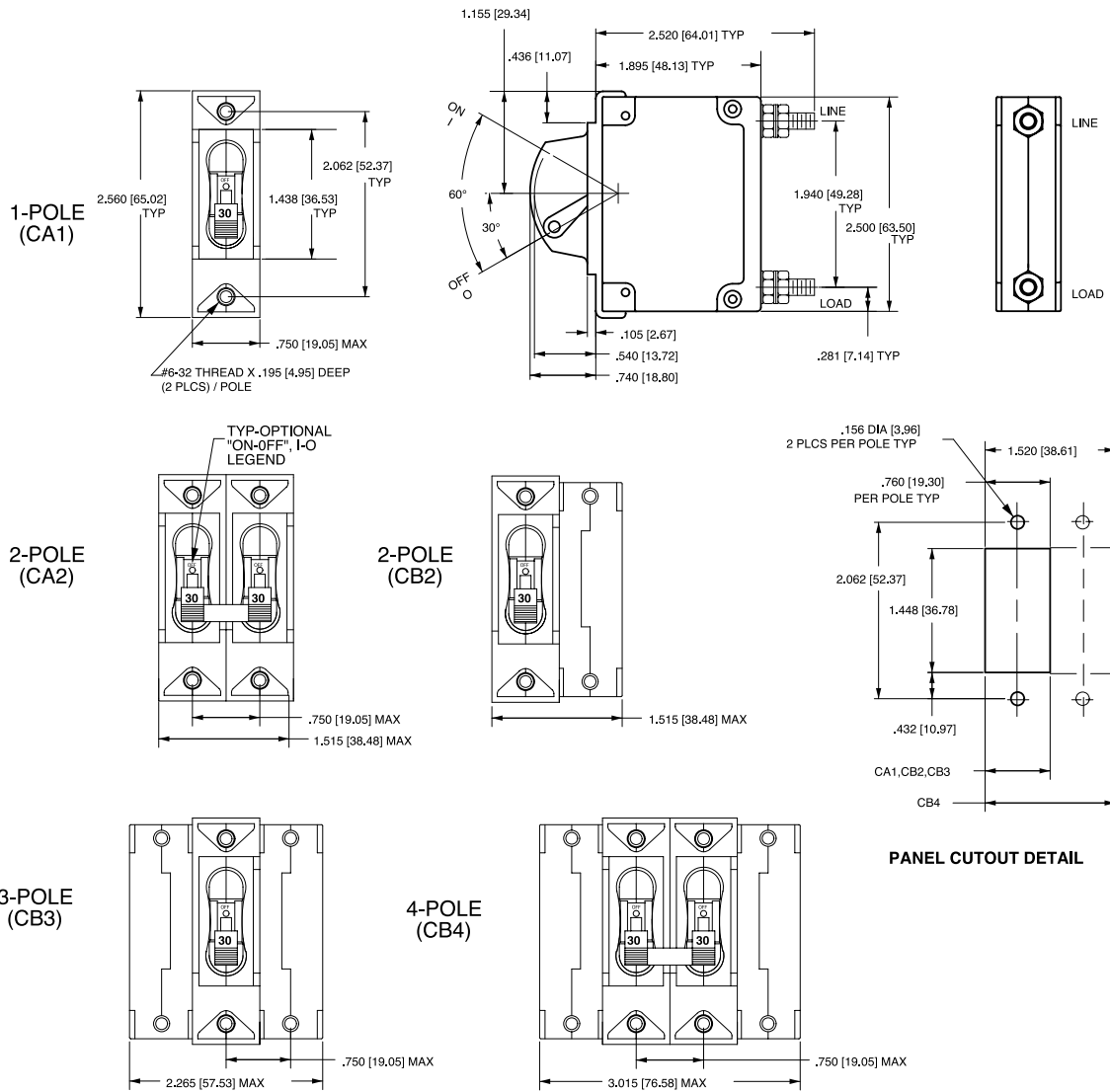

*Handguard available as special catalog number only

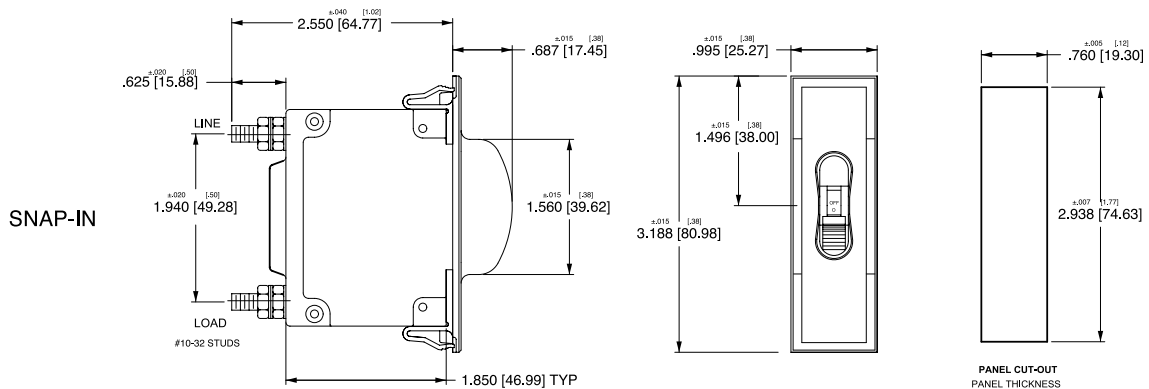

Notes:

- 1 All dimensions are in inches [millimeters].
- 2 Tolerance ± 0.020 [.51] unless otherwise specified.

Dimensional Specifications: in. [mm]

1-POLE (CA1)
w/ ARC CHUTE BARRIER

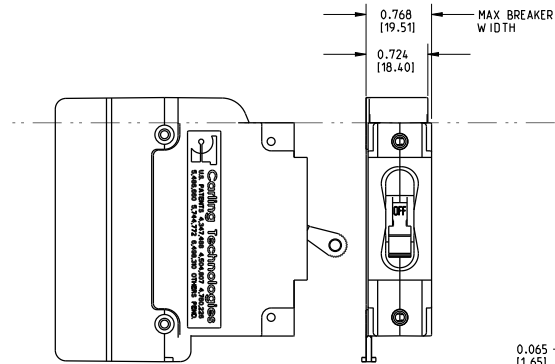

3-POLE (CA3)
w/ ARC CHUTE BARRIER

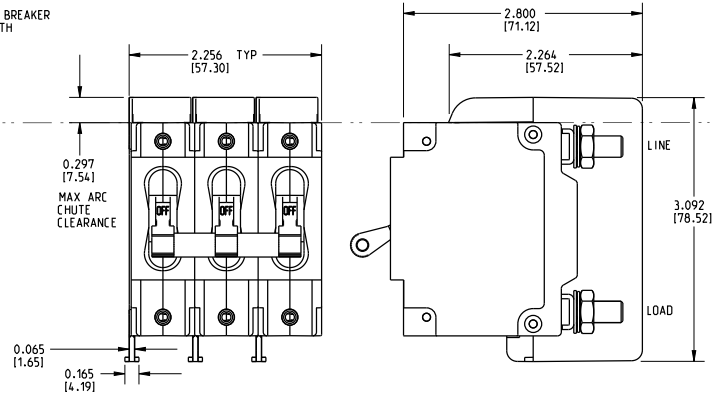

INDICATE "ON"

1-POLE (CC1, CD1)
w/ ARC CHUTE (NO BARRIER)

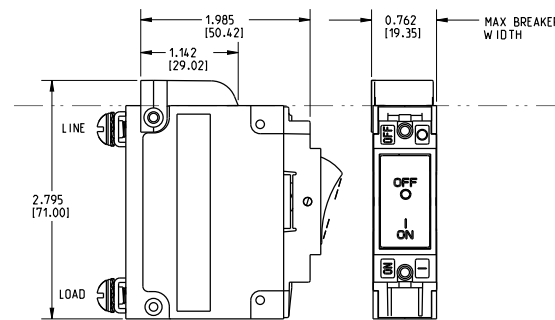

3-POLE (CC3, CD3)
w/ ARC CHUTE BARRIER

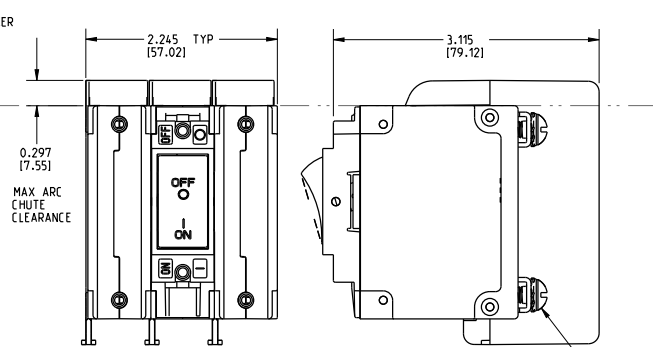

SCREW TYPE TERMINALS IN SERIES TRIP CIRCUIT CONFIGURATION SHOWN.

INDICATE "OFF" / SINGLE COLOR

1-POLE (CF1, CG1, C11, C21)
w/ ARC CHUTE (NO BARRIER)

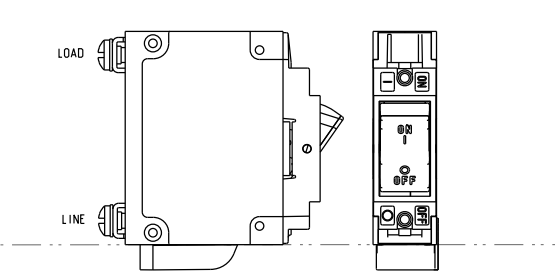

3-POLE (CF3, CG3, C13, C23)
w/ ARC CHUTE BARRIER

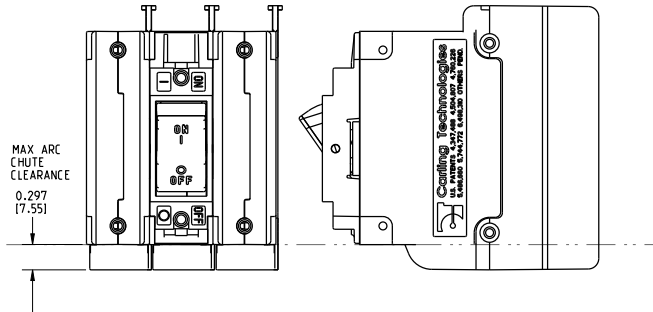

Notes:

- 1 Only 1-pole and 3-pole configurations shown. Arc chute (without barrier) and arc chute barrier also available for 2-pole construction.
- 2 Dimensions apply to all variations shown.
- 3 Notice that line and load terminal orientation for indicate on and indicate off rocker circuit breakers are opposite.
- 4 Screw type terminals shown for Rocker style (CF1, C11, etc) circuit breakers. For other terminal configurations see circuit and terminal diagrams.
- 5 All dimensions are in inches [millimeters].
- 6 Tolerance $\pm .020$ unless otherwise specified.
- 7 Must be ordered under a special catalog number.

Dimensional Specifications: in. [mm]

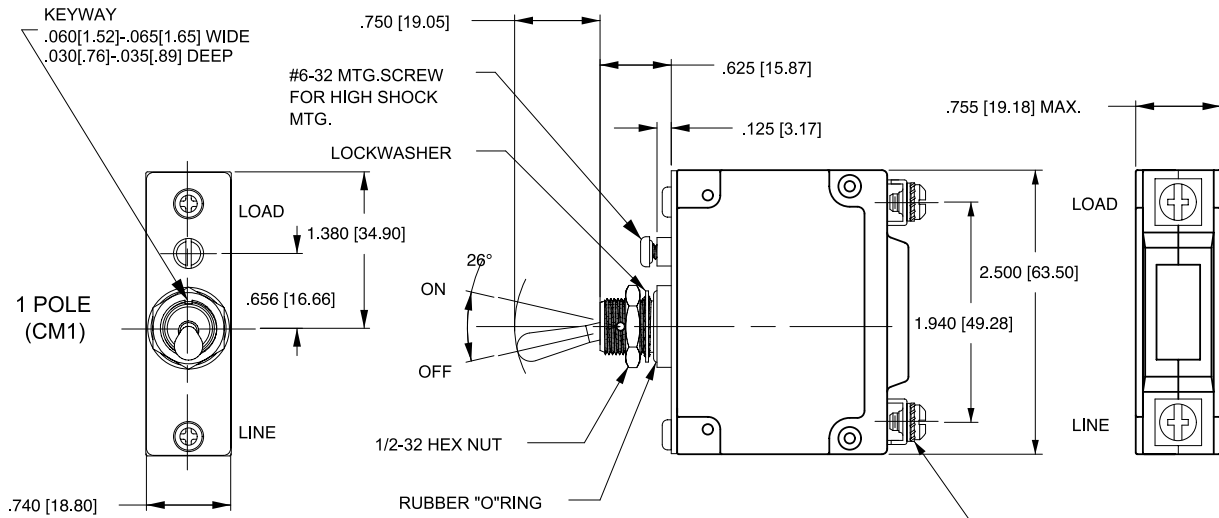

SCREW TYPE TERMINALS IN SERIES TRIP CIRCUIT CONFIGURATION SHOWN. FOR OTHER CONFIGURATIONS SEE CIRCUIT & TERMINAL DIAGRAMS

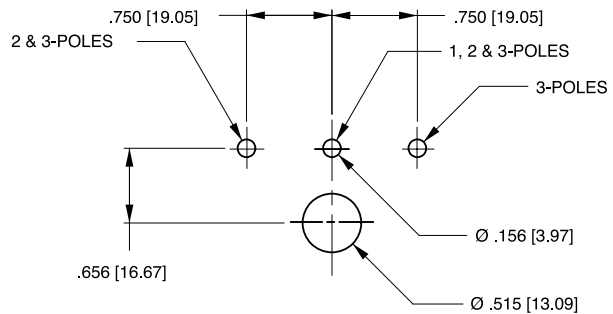
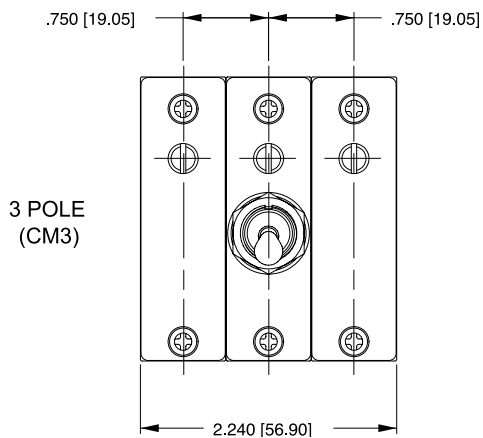
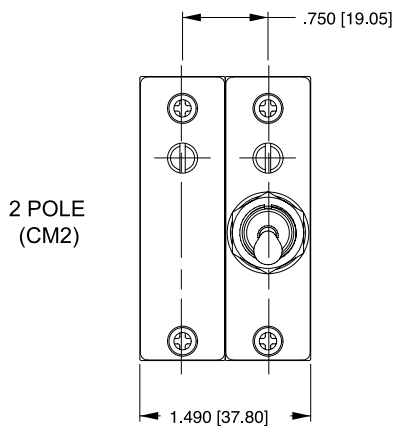

PANEL CUTOUT DETAIL
 TOLERANCES ±.005[.13]

Notes:

- 1 All dimensions are in inches [millimeters].
- 2 Tolerance ±.020 [.51] unless otherwise specified.

Circuit & Terminal Diagrams: in. [mm]

CIRCUIT BREAKER PROFILE	CIRCUIT SCHEMATIC		CIRCUIT CODE	AUX SWITCH CODE	CIRCUIT SCHEMATIC		CIRCUIT CODE	AUX SWITCH CODE
	ANSI	IEC			ANSI	IEC		
<p>SERIES TRIP (2 TERM'S.)</p>	<p>SWITCH ONLY (NO COIL)</p>		A	0	<p>SWITCH TRIP</p>		BC	0
<p>SERIES TRIP W/AUX. SWITCH (5 TERM'S.)</p>	<p>SWITCH ONLY (NO COIL) WITH AUXILIARY SWITCH</p>		A	2 3 4	<p>SERIES TRIP WITH AUXILIARY SWITCH</p>		BC	2 3 4
<p>SHUNT TRIP (3 TERM'S.)</p>	<p>SHUNT TRIP</p>		DE	0	<p>DUAL COIL; SERIES TRIP CURRENT COIL, SHUNT TRIP VOLTAGE COIL</p>		H	0
<p>SHUNT TRIP (4 TERM'S.)</p>	<p>RELAY TRIP</p>		FG	0	<p>DUAL COIL; SERIES TRIP CURRENT COIL, RELAY TRIP VOLTAGE COIL</p>		K	0

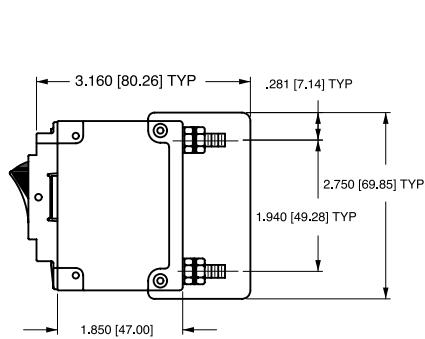

BARRIER FOR UL-RECOGNIZED MULTI-POLE BREAKERS

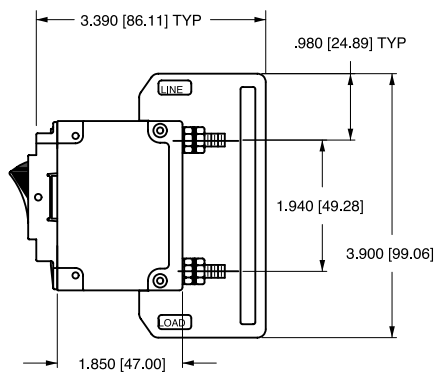

BARRIER FOR UL-489 LISTED MULTI-POLE BREAKERS

- Notes:
- 1 All dimensions are in inches [millimeters].
 - 2 Tolerance ± 0.020 [.51] unless otherwise specified.
 - 3 Schematic shown represents current trip circuit.

Dimensional Specifications: in. [mm]

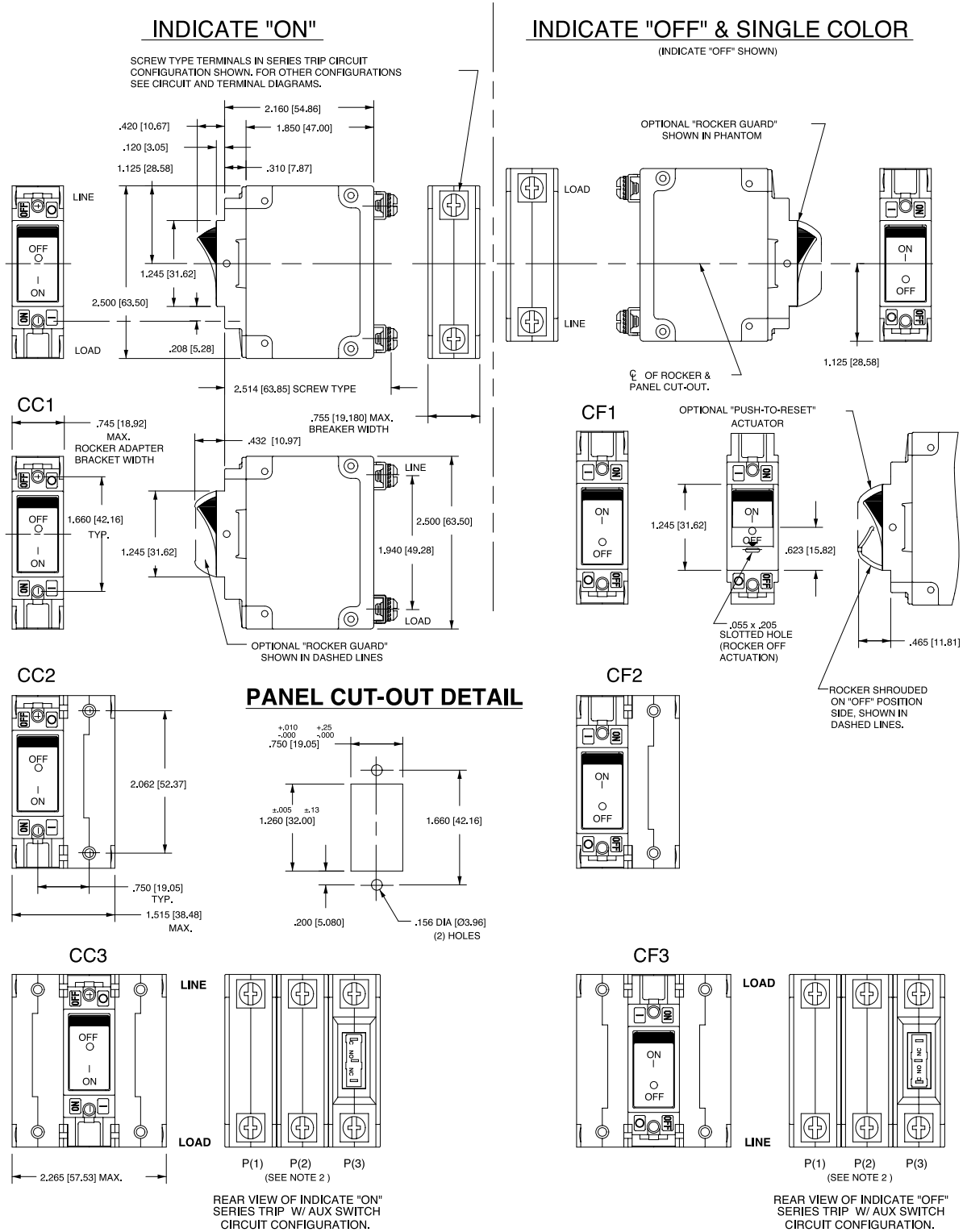

Notes:

- 1 Dimensions apply to all variations shown. Notice that circuit breaker line and load terminal orientation on indicate OFF is opposite of indicate ON.
- 2 For pole orientation with horizontal legend, rotate front view clockwise 90°.
- 3 All dimensions are in inches [millimeters].
- 4 Tolerance ± 0.020 [.51] unless otherwise specified.

Dimensional Specifications: in. [mm]

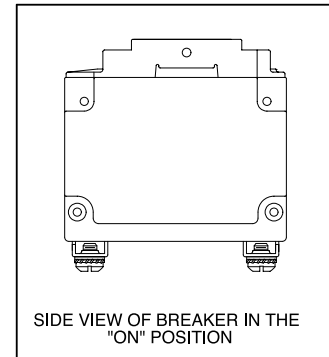
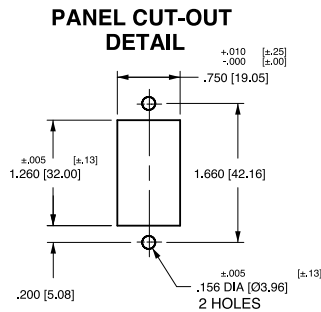
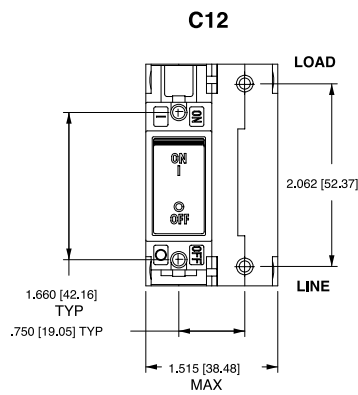
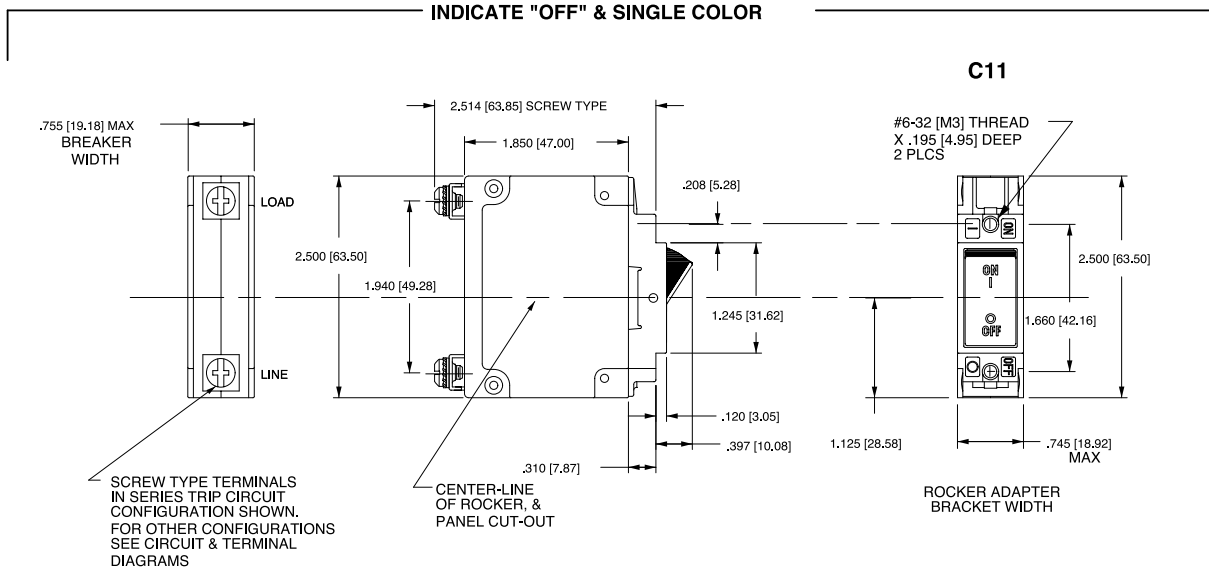

PUSH-TO-RESET ACTUATOR

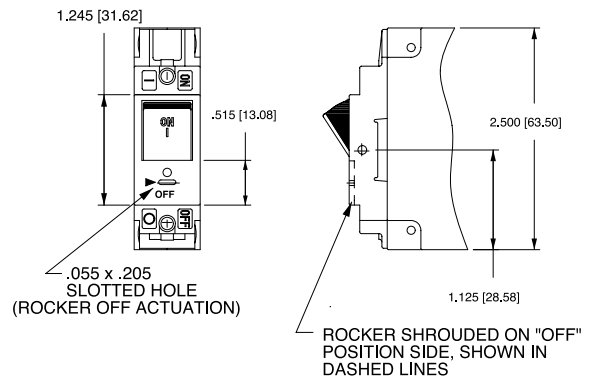

ACTUATOR SIDE VIEW (SURFACE CONTOURS)

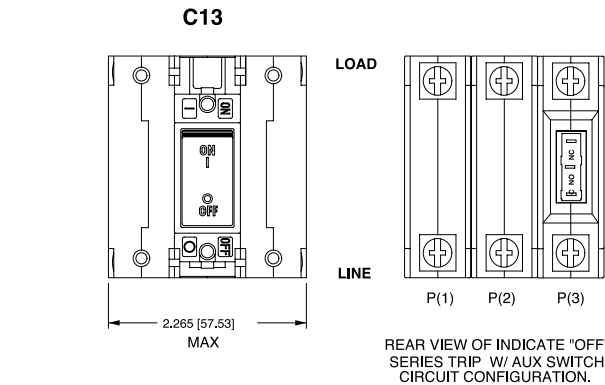
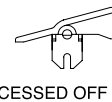
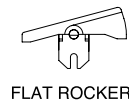

- Notes:
- 1 For pole orientation with horizontal legend, rotate front view clockwise 90°.
 - 2 All dimensions are in inches [millimeters].
 - 3 Tolerance ±.020 [.51] unless otherwise specified.

E-Series

CIRCUIT BREAKER

The E-Series hydraulic-magnetic circuit breaker is ideally suited for higher current and voltage applications. It is UL listed and CSA certified for branch circuit protection, which does not require a fuse back up. It is also UL recognized and CSA certified as a supplementary protector and as a manual motor controller.

Its physical features include front and back mounting, screw and stud terminals and heavy duty box wire connectors for solid wire or a pressure plate connector for standard wire. The E-series is available with handle actuators and can be configured as .1-125 amps, up to 600VAC or 125VDC, with choice of time delays, actuator colors and 1 to 6 poles configuration. Additionally, a Power Selector device is also available.



Product Highlights:

- ♦ UL listed and CSA certified
- ♦ Certified for circuit branch protection
- ♦ Recognized as a supplementary protector and as a manual motor controller
- ♦ Optional power selector device

Electrical

Maximum Voltage 600VAC 50/60 Hz, 125VDC (See Table A)

Current Ratings Standard current coils: 0.100, 0.250, 0.500, 1.00, 2.50, 5.00, 7.50, 10.0, 15.0, 20.0, 25.0, 30.0, 50.0, 60.0, 70.0 & 100 Amp.

Auxiliary Switch Rating SPDT; 10.1A 250VAC, 1.0A 65VDC; 0.5A 80VDC, 0.1A 125VAC (with gold contacts).

Insulation Resistance Minimum of 100 Megohms at 500 VDC.

Dielectric Strength UL, CSA: 2200 V 50/60 Hz for one minute between all electrically isolated terminals. E-Series Circuit Breakers comply with the 8mm spacing and 3750V 50/60 Hz dielectric requirements from hazardous voltage to operator accessible surfaces, between adjacent poles and from main circuits to auxiliary circuits per Publications EN 60950 and VDE 0805.

Resistance, Impedance Values from Line to Load Terminal - based on Series Trip Circuit Breaker.

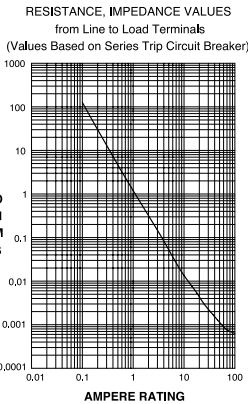

CURRENT (AMPS)	TOLERANCE (%)
0.10 - 5.0	± 15
5.1 - 20.0	± 25
20.1 - 50.0	± 35

Pulse Tolerance Curves

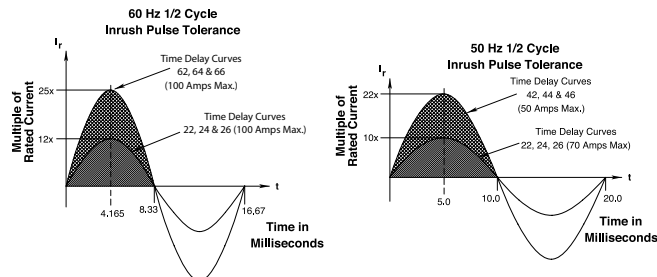

Mechanical

Endurance 10,000 ON-OFF operations @ 6 per minute; with rated Current and Voltage.

Trip Free All E-Series Circuit Breakers will trip on overload, even when Handle is forcibly held in the ON position.

Trip Indication The operating Handle moves positively to the OFF position when an overload causes the breaker to trip.

Physical

Number of Poles 1 - 6

Mounting A 3" minimum spacing must be provided between the circuit breaker arc venting area on back connected E-Series circuit breakers and grounded obstructions. E-Series circuit breakers must be mounted on a vertical surface.

Connectors, Box Type Front connected E-Series circuit breakers are supplied with box type pressure connectors that accept copper or aluminum conductors as follows: 1/0-14 Copper, 1/0-12 Aluminum. Series and Switch Only, (with or without auxiliary switch). Shunt with current coils.

Internal Circuit Configuration Series and Switch Only, (with or without auxiliary switch). Shunt with current coils.

Weight Approximately 252 grams/pole (Approximately 9 ounces/pole)

Standard Colors Housing-Black; Actuator - See Ordering Scheme.

Environmental

Designed in accordance with requirements of specification MIL PRF-55629 & MIL-STD-202G as follows:

Shock Withstands 100 Gs, 6ms, sawtooth while carrying rated current per Method 213, Test Condition "I".

Vibration Withstands 0.060" excursion from 10-55 Hz, and 10 Gs 55-500 Hz, at rated current per Method 204C, Test Condition A.

Moisture Resistance Method 106D, i.e., ten 24-hour cycles @ +25°C to +65°C, 80-98% RH.

Salt Spray Method 101, Condition A (90-95% RH @ 5% NaCl Solution, 96 hrs).

Thermal Shock Method 107D, Condition A (Five cycles @ -55°C to +25°C to +85°C to +25°C).

Operating Temperature -40° C to +85° C

*Manufacturer reserves the right to change product specification without prior notice.

Electrical Tables

Table A: Lists UL Listed (489) & CSA Certified (C22.2 No. 5) configurations & performance capabilities as a Molded Case Circuit Breaker.

E SERIES TABLE A : UL489 LISTED BRANCH CIRCUIT BREAKERS						
CIRCUIT CONFIGURATION	VOLTAGE			CURRENT RATING	INTERRUPTING CAPACITY (AMPS)	HIGH INTERRUPTING CAPACITY (AMPS)
	MAX. RATING	FREQUENCY	PHASE	FULL LOAD AMPS	WITHOUT BACKUP FUSE	
SERIES	80	DC	---	0.10 - 100	5,000	50,000
	125	DC	---	0.10 - 100	5,000	10,000
	125	DC	---	0.10 - 125	10,000	---
	120	50 / 60	1	0.10 - 125	10,000	---
	240	50 / 60	1	0.10 - 30	5,000	10,000
	240	50 / 60	1	31 - 100	5,000	---
	120 / 240	50 / 60	1	0.10 - 30	5,000	10,000
	120 / 240	50 / 60	1	31 - 100	5,000	---
	120 / 240	50 / 60	1	101 - 125	10,000	---
	240	50 / 60	3	0.10 - 100	5,000	---

Table B: Lists UL Recognized & CSA Accepted configurations & performance capabilities as a Component Supplementary Protector.

E-SERIES TABLE B: COMPONENT SUPPLEMENTARY PROTECTORS									
CIRCUIT CONFIGURATION	VOLTAGE			CURRENT RATING		SHORT CIRCUIT CAPACITY (AMPS)		APPLICATION CODES	
	MAX. RATING	FREQUENCY	PHASE	FULL LOAD AMPS	GENERAL PURPOSE AMPS	UL/CSA		UL	CSA
						WITH BACKUP FUSE ³	WITHOUT BACKUP FUSE		
SERIES & SHUNT	125	DC	---	0.02 - 100	---	---	5,000	TC1,2, OL1, U1	TC1,2, OL1, U1
	125	DC	---	---	101 - 120	---	5,000	TC1,2, OL0, U1	TC1,2, OL0, U1
	150	DC	---	---	0.02 - 125	---	5,000	TC1, OL0, U3	TC1, OL0, U3
	160	DC	---	0.02 - 100	---	---	5,000	TC1,2, OL1, U1	TC1,2, OL1, U1
	150 / 300	DC	---	0.02 - 100	---	---	5,000	TC1,2, OL1, U1	TC1,2, OL1, U1
	120 / 240	50 / 60	1	---	0.02 - 100	---	5,000	TC1,2, OL0, U1	TC1,2, OL0, U1
	240	50 / 60	1	0.02 - 100	---	---	5,000	TC1,2, OL1, U1	TC1,2, OL1, U1
	250	50 / 60	1	0.02 - 100	---	10,000	---	TC1,2, OL1, C1	TC1,2, OL1, C1
	277	50 / 60	1	0.02 - 100	---	---	5,000	TC1,2, OL1, U1	TC1,2, OL1, U1
						10,000	---	TC1,2, OL1, C1	TC1,2, OL1, C1
	480	50 / 60	1 & 3	0.02 - 100	---	10,000	---	TC1,2, OL1, C1	TC1,2, OL1, C1
	480 ¹	50 / 60	1 & 3	0.02 - 50	---	10,000	---	TC1,2, OL1, C1	TC1,2, OL1, C1
600	50 / 60	1 & 3	0.02 - 100	---	10,000	---	TC1,2, OL1, C1	TC1,2, OL1, C1	
600 ²	DC	---	---	0.02 - 125	---	5,000	TC1, OL0, U3	TC1, OL0, U3	
SWITCH ONLY	125	DC	---	0.02 - 120					
	160	DC	---	0.02 - 100					
	240	50 / 60	1	0.02 - 100					
	277	50 / 60	1	0.02 - 100					
	480	50 / 60	1 & 3	0.02 - 100					
	600	50 / 60	1 & 3	0.02 - 100					

Notes:
 1 Per pole opposite polarity rating - Delta Configuration.
 2 4 Poles connected in series
 3 Requires branch circuit backup with a UL Listed Type K5 or RK5 fuse rated 15A minimum and no more than 4 times full load amp rating and not to exceed 225A.

Electrical Tables

Table C: Lists UL Recognized, CSA Accepted and VDE Certified configurations and performance capabilities as a Component Supplementary Protector.

E -SERIES TABLE C: COMPONENT SUPPLEMENTARY PROTECTORS WITH VDE										
CIRCUIT CONFIGURATION	VOLTAGE			CURRENT RATING FULL LOAD AMPS	SHORT CIRCUIT CAPACITY (AMPS)			APPLICATION CODES		CONSTRUCTION NOTES
	MAX. RATING	FREQUENCY	PHASE		UL/CSA		VDE (Icn)	UL	CSA	
				WITH BACKUP FUSE ¹	WITHOUT BACKUP FUSE	WITHOUT BACKUP FUSE				
SERIES & SHUNT	125	DC	---	0.1 - 100	---	5,000	5,000	TC1,2, OL1, U1	TC1,2, OL1, U1	1 or 2 Poles
	240	50 / 60	1 & 3	0.1 - 100	---	5,000	5,000	TC1,2, OL1, U1	TC1,2, OL1, U1	1 - 5 Poles. Up to 4 Current Poles, 1 Voltage Pole
	415	50 / 60	1 & 3	0.1 - 100	10,000	---	4,000	TC1,2, OL1, C1	TC1,2, OL1, C1	2 - 5 Poles. Up to 4 Current Poles, 1 Voltage Pole
SWITCH ONLY	125	DC	---	0.1 - 125						
	240	50 / 60	1 & 3	0.1 - 100						
	415	50 / 60	1 & 3	0.1 - 100						

Notes:

¹ Requires branch circuit backup with a UL LISTED Type K5 or RK5 fuse rated 15A minimum and no more than 4 times full load amp rating and not to exceed 225 amps.

Table D: Lists UL Recognized, CSA Accepted configurations and performance capabilities as Protectors, Supplementary for Marine Electrical and Fuel Systems (Guide PEQZ2, File E75596). Ignition Protected per UL 1500. UL Classified Small Craft Electrical Devices, Marine in accordance with ISO 8846 (Guide UZMK, File MQ1515) as Marine Supplementary Protectors.

E SERIES TABLE D : UL1500 (Marine Ignition Protection)							
CIRCUIT CONFIGURATION	VOLTAGE			CURRENT RATING FULL LOAD AMPS	SHORT CIRCUIT CAPACITY (AMPS) WITHOUT BACKUP FUSE	APPLICATION CODES	
	MAX. RATING	FREQUENCY	PHASE			UL	CSA
				SERIES	65		
125	50 / 60	1	0.02 - 100		1,500	TC1,2,OL1,U1	TC1,2,OL1,U1
250	50 / 60	1	0.02 - 100		1,500	TC1,2,OL1,U1	TC1,2,OL1,U1

Agency Certifications

UL Recognized

UL Standard 1077



Component Recognition Program as Protectors, Supplementary (Guide QVNU2, File E75596)

CSA Accepted



Component Supplementary Protector (Class 3215 30, File 047848 0 000)
CSA Standard C22.2 No. 235

Component Recognition Program as Manual Motor Controls (Guide NLRV2, File E135367)

CSA Certified



Circuit Breaker Molded Case (Class 1432 01, File 093910),
CSA Standard C22.2 No. 5.1 - M

UL Standard 1500



Protectors, Supplementary for Marine Electrical & Fuel Systems (Guide PEQZ2, File E75596)
Ignition Protection

TUV Certified



EN60934 under License No. R72031056

UL Listed

UL Standard 489



Circuit Breakers, Molded Case (Guide DIVQ, File E129899)

VDE Certified



EN60934, VDE 0642 under File No. 10537

E A 2 - B 0 - 24 - 450 - 1 2 A - C B

1 Series 2 Actuator 3 Poles 4 Circuit 5 Auxiliary Switch 6 Frequency & Delay 7 Current Rating 8 Terminal 9 Actuator Color 10 Mounting/Barriers 11 Maximum Application Rating 12 Agency Approval

1 SERIES

E

2 ACTUATOR

A Handle, one per pole

3 POLES¹

1 One	3 Three	5 Five
2 Two	4 Four	6 Six

4 CIRCUIT²

A ³ Switch Only (no coil)	E Shunt Trip (voltage)
B Series Trip (current)	F Relay Trip (current)
C Series Trip (voltage)	G Relay Trip (voltage)
D Shunt Trip (current)	

5 AUXILIARY SWITCH⁴

0 without Auxiliary Switch	6 S.P.S.T. 0.110 Q.C. Terminals
2 S.P.D.T. 0.110 Q.C. Terminals	7 S.P.S.T. 0.110 Q.C. Terminals (Gold Contacts)
3 S.P.D.T. 0.139 Solder Lug	8 S.P.S.T. 0.187 Q.C. Terminals
4 S.P.D.T. 0.110 Q.C. Terminals (Gold Contacts)	9 S.P.D.T. 0.187 Q.C. Terminals

6 FREQUENCY & DELAY

03 ³ DC 50/60Hz, Switch Only	34 DC, 50/60Hz Medium
10 ⁵ DC Instantaneous	36 DC, 50/60Hz Long
12 DC Short	62 50/60Hz Short, Hi-Inrush
14 DC Medium	64 50/60Hz Medium, Hi-Inrush
16 DC Long	66 50/60Hz Long, Hi-Inrush
20 ⁵ 50/60Hz Instantaneous	72 DC, Short, Hi-Inrush
22 50/60Hz Short	74 DC, Medium, Hi-Inrush
24 50/60Hz Medium	76 DC, Long, Hi-Inrush
26 50/60Hz Long	92 ⁶ DC, 50/60Hz Short, Hi-Inrush
30 DC, 50/60Hz Instantaneous	94 ⁶ DC, 50/60Hz Medium, Hi-Inrush
32 DC, 50/60Hz Short	96 ⁶ DC, 50/60Hz Long, Hi-Inrush

7 CURRENT RATING (AMPERES)⁷

CODE	AMPERES				
020	0.020	235	0.350	430	3.000
025	0.025	240	0.400	435	3.500
030	0.030	245	0.450	440	4.000
035	0.035	250	0.500	445	4.500
040	0.040	255	0.550	450	5.000
045	0.045	260	0.600	455	5.500
050	0.050	265	0.650	460	6.000
055	0.055	270	0.700	465	6.500
060	0.060	275	0.750	470	7.000
065	0.065	280	0.800	475	7.500
070	0.070	285	0.850	480	8.000
075	0.075	290	0.900	485	8.500
080	0.080	295	0.950	490	9.000
085	0.085	410	1.000	495	9.500
090	0.090	512	1.250	610	10.000
090	0.095	415	1.500	710	10.500
210	0.100	517	1.750	611	11.000
215	0.150	420	2.000	711	11.500
220	0.200	522	2.250	612	12.000
225	0.250	425	2.500	712	12.500
230	0.300	527	2.750	613	13.000
				912 ⁸	125.000

OR VOLTAGE COIL (MIN. TRIP RATING, VOLTS)⁵

A06 6 DC, 5 DC	A65 65 DC, 55 DC	J48 48 AC, 40 AC
A12 12 DC, 10 DC	B25 125 DC, 100 DC	J65 65 AC, 55 AC
A18 18 DC, 15 DC	J06 6 AC, 5 AC	K20 120 AC, 65 AC
A24 24 DC, 20 DC	J12 12 AC, 10 AC	L40 240 AC, 130 AC
A32 32 DC, 25 DC	J18 18 AC, 15 AC	
A48 48 DC, 40 DC	J24 24 AC, 20 AC	

Notes:

- VDE approval on 1-5 poles only. Standard multi-pole units identical poles except when specifying auxiliary switch - (see Note 4). For mixed ratings, consult factory.
- Switch Only & Series Trip construction available with either front or back connected terminals. Shunt construction available with back connected terminals, (Terminal Codes 1 & 2) only. Circuit Codes B,C & D are VDE approved.
- Switch Only construction: 30 amps or less select Current Rating Code 630; 31-70 amps, select Current Rating code 670; 71-100 amps, select Current Rating Code 810; 101-125 amps Select Current Rating Code 912. Switch Only is VDE approved only if tied to a protected pole.

8 TERMINAL¹²

BACK CONNECTED (FRONT MOUNTED ONLY)

	MAX. RATING
1 ⁹ 10-32 Stud (All Terminals)	50 A
2 ⁹ 1/4-20 Stud (All Terminals)	120 A
A ⁹ M5 Stud (Line & Load)	50 A
B ⁹ M6 Stud (Line & Load)	100 A

FRONT CONNECTED (BACK MOUNTED ONLY)

	MAX. RATING
3 ¹⁰ Box Wire Connector (Line & Load)	100 A
C ¹¹ Box Wire Connector with Pressure Plate (Line & Load)	100 A
4 10-32 Screw (Line & Load)	50 A
D M5 Screw (Line & Load)	50 A
5 10-32 "Bus-Type" Screw (Line), 10-32 Screw (Load)	50 A
E M5 "Bus-Type" Screw (Line), 10-32 Screw (Load)	50 A
6 ¹⁰ 10-32 "Bus-Type" Screw (Line), Box Wire Connector (Load)	100 A
F ¹¹ 10-32 "Bus-Type" Screw (Line), Box Wire Connector with Pressure Plate (Load)	100 A
7 1/4-20 Screw (Line & Load)	100 A
G M6 Screw (Line & Load)	100 A
8 1/4-20 "Bus-Type" Screw (Line), 1/4-20 Screw (Load)	100 A
H M6 "Bus-Type" Screw (Line), M6 Screw (Load)	100 A
9 ¹⁰ 1/4-20 "Bus-Type" Screw (Line), Box Wire Connector (Load)	100 A
J ¹¹ 1/4-20 "Bus-Type" Screw (Line), Box Wire Connector with Pressure Plate (Load)	100 A

9 ACTUATOR COLOR & LEGEND¹³

Actuator Color	I-O	ON-OFF	Dual	Legend Color
White	A	B	1	Black
Black	C	D	2	White
Red	F	G	3	White
Green	H	J	4	White
Blue	K	L	5	White
Yellow	M	N	6	Black
Gray	P	Q	7	Black
Orange	R	S	8	Black

10 MOUNTING / BARRIERS

BACK CONNECTED (FRONT MOUNTED ONLY)

Mounting Inserts

A 6-32
B ISO M3

FRONT CONNECTED (BACK MOUNTED ONLY)¹⁴

Back Mounting Foot Type	Front Mounting Inserts (Optional Use)
C Short	6-32
D Short	ISO M3
E Long	6-32
F Long	ISO M3

11 MAXIMUM APPLICATION RATING¹⁵

A 65 VDC, 120 A	G ¹⁶ 600 VAC, 100 A
B 125 VDC, 120 A	H ¹⁶ 480 VAC, 100 A
C 120/240 VAC, 100 A	J ¹⁶ 415 VAC, 100 A
D 240 VAC, 100 A	L ¹⁶ 160 VDC, 100 A
E ¹⁶ 277/480 VAC, 100 A	T 125 VDC/240 VAC, 100 A
F 277 VAC, 100 A	W ¹⁶ 125 VDC/415 VAC, 100 A

12 AGENCY APPROVAL

B UL 1077 / UL508 Recognized & CSA Accepted
D UL 1077 Recognized, CSA Accepted, & VDE Certified

- Auxiliary Switch available on Switch Only and Series Trip units. On multi-pole units, only one auxiliary switch is normally supplied mounted in the extreme right pole. Back mounted units require special mounting provisions when auxiliary switch is specified. VDE approval on Auxiliary Switch Codes 0.2, 3 & 4 only.
- Voltage Trip Coils are not rated for continuous duty. Available only with Frequency & Delay Codes 10 & 20. Series Trip construction with a voltage coil s VDE approved only if tied to a protected pole.
- Frequency & Delay Codes 92, 94 & 96 are not VDE Certified.
- Current Coil Ratings 0.100 - 100 amps are VDE Certified.
- 125 A rating (Code 912) available as a Switch Only (Circuit Code A), rated 125 VDC (Code B).
- An Anti-Flash Over Barrier is supplied between poles on multi-pole units with 10-32 (Terminal Code 1), 1/4-20 (Code 2), M5 (Code A), and M6 (Code B) terminals per UL requirement.
- Box Wire Connector will accept #14 through 0 AWG. copper wire or #12 through 0 AWG. aluminum wire.
- Box Wire Connector with Pressure Plate for stranded wire, consult factory for details.
- Terminal Codes A,B,D,E,G & H are not VDE Certified.
- VDE approvals require Dual (I-O, ON-OFF) or I-O markings on all handles.
- Back Mounted breakers can also be front mounted by utilizing the proper front panel mounting inserts normally supplied. However, terminal connections must be made prior to mounting.
- Application ratings B,D,J,T & W are available with VDE.
- 415, 480 & 600 VAC ratings require 3 or 4 pole break 3Ø and 2 pole break 1Ø.

E - **A** **2** - **B** **0** - **24** - **450** - **1** **2** **A** - **C** **C**

1 Series	2 Actuator	3 Poles	4 Circuit	5 Auxiliary Switch	6 Frequency & Delay	7 Current Rating	8 Terminal	9 Actuator Color	10 Mounting/ Barriers	11 Maximum Application Rating	12 Agency Approval
-------------	---------------	------------	--------------	-----------------------	------------------------	---------------------	---------------	---------------------	--------------------------	----------------------------------	-----------------------

1 SERIES
E

2 ACTUATOR
A Handle, one per pole

3 POLES¹

1 One	3 Three	5 Five
2 Two	4 Four	6 Six

4 CIRCUIT²
B³ Series Trip (current)
C³ Series Trip (voltage)

5 AUXILIARY SWITCH⁴

0 without Auxiliary Switch	6 S.P.S.T. 0.110 Q.C. Terminals
2 S.P.D.T. 0.110 Q.C. Terminals	7 S.P.S.T. 0.110 Q.C. Terminals (Gold Contacts)
3 S.P.D.T. 0.139 Solder Lug	8 S.P.S.T. 0.187 Q.C. Terminals
4 S.P.D.T. 0.110 Q.C. Terminals (Gold Contacts)	9 S.P.D.T. 0.187 Q.C. Terminals

6 FREQUENCY & DELAY

10 ⁵ DC Instantaneous	62 50/60Hz Short, Hi-Inrush
12 DC Short	64 50/60Hz Medium, Hi-Inrush
14 DC Medium	66 50/60Hz Long, Hi-Inrush
16 DC Long	72 DC, Short, Hi-Inrush
20 ⁵ 50/60Hz Instantaneous	74 DC, Medium, Hi-Inrush
22 50/60Hz Short	76 DC, Long, Hi-Inrush
24 50/60Hz Medium	
26 50/60Hz Long	

7 CURRENT RATING (AMPERES)⁷

CODE	AMPERES						
020	0.020	235	0.350	430	3.000	614	14.000
025	0.025	240	0.400	435	3.500	615	15.000
030	0.030	245	0.450	440	4.000	616	16.000
035	0.035	250	0.500	445	4.500	617	17.000
040	0.040	255	0.550	450	5.000	618	18.000
045	0.045	260	0.600	455	5.500	620	20.000
050	0.050	265	0.650	460	6.000	622	22.000
055	0.055	270	0.700	465	6.500	624	24.000
060	0.060	275	0.750	470	7.000	625	25.000
065	0.065	280	0.800	475	7.500	630	30.000
070	0.070	285	0.850	480	8.000	635	35.000
075	0.075	290	0.900	485	8.500	640	40.000
080	0.080	295	0.950	490	9.000	650	50.000
085	0.085	410	1.000	495	9.500	660	60.000
090	0.090	512	1.250	610	10.000	670	70.000
090	0.095	415	1.500	710	10.500	680	80.000
210	0.100	517	1.750	611	11.000	690	90.000
215	0.150	420	2.000	711	11.500	810	100.000
220	0.200	522	2.250	612	12.000	811	110.000
225	0.250	425	2.500	712	12.500	812	120.000
230	0.300	527	2.750	613	13.000	912 ⁸	125.000

OR VOLTAGE COIL (MIN. TRIP RATING, VOLTS)⁵

A06 6 DC, 5 DC	A65 65 DC, 55 DC	J48 48 AC, 40 AC
A12 12 DC, 10 DC	B25 125 DC, 100 DC	J65 65 AC, 55 AC
A18 18 DC, 15 DC	J06 6 AC, 5 AC	K20 120 AC, 65 AC
A24 24 DC, 20 DC	J12 12 AC, 10 AC	L40 240 AC, 130 AC
A32 32 DC, 25 DC	J18 18 AC, 15 AC	
A48 48 DC, 40 DC	J24 24 AC, 20 AC	

8 TERMINAL⁷
BACK CONNECTED (FRONT MOUNTED ONLY) **MAX. RATING**
1⁸ 10-32 Stud (All Terminals) 50 A
2⁸ 1/4-20 Stud (All Terminals) 125 A
FRONT CONNECTED (BACK MOUNTED ONLY) **MAX. RATING**
3⁹ Box Wire Connector (Line & Load) 100 A
C¹⁰ Box Wire Connector with Pressure Plate (Line & Load) 100 A
4 10-32 Screw (Line & Load) 50 A
5 10-32 "Bus-Type" Screw (Line), 10-32 Screw (Load) 50 A
6⁹ 10-32 "Bus-Type" Screw (Line), Box Wire Connector (Load) 100 A
F¹⁰ 10-32 "Bus-Type" Screw (Line), Box Wire Connector with Pressure Plate (Load) 100 A
7 1/4-20 Screw (Line & Load) 125 A
8 1/4-20 "Bus-Type" Screw (Line), 1/4-20 Screw (Load) 100 A
9⁹ 1/4-20 "Bus-Type" Screw (Line), Box Wire Connector (Load) 100 A
J¹⁰ 1/4-20 "Bus-Type" Screw (Line), Box Wire Connector with Pressure Plate (Load) 100 A

9 ACTUATOR COLOR & LEGEND¹²

Actuator Color	ON-OFF	Dual	Legend Color
White	B	1	Black
Black	D	2	White
Red	G	3	White
Green	J	4	White
Blue	L	5	White
Yellow	N	6	Black
Gray	Q	7	Black
Orange	S	8	Black

10 MOUNTING / BARRIERS
BACK CONNECTED (FRONT MOUNTED ONLY)
Mounting Inserts
A 6-32
B ISO M3
FRONT CONNECTED (BACK MOUNTED ONLY)¹¹

C Short	Back Mounting Foot Type	Front Mounting Inserts (Optional Use)
D Short		6-32
E Long		ISO M3
F Long		6-32
		ISO M3

11 MAXIMUM APPLICATION RATING¹⁵
1 120 VAC
B 125 VDC, 120 A
C¹³ 120/240 VAC, 100 A
D 240 VAC, 100 A

12 AGENCY APPROVAL
C UL 489 Listed & CSA Certified
F UL 489 Listed, CSA Certified, & VDE Certified

- Notes:
1 Standard multi-pole units identical poles except when specifying auxiliary switch - (see Note 4). For mixed ratings, consult factory. VDE Certification on 1-5 poles only.
2 Series Trip construction available with either front or back connected terminals.
3 Series Trip construction with a voltage coil is not available as a single pole unit and must be tied to a protected pole.
4 On multi-pole units, only one auxiliary switch is normally supplied mounted in the extreme right pole per Figure A. Back mounted units require special mounting provisions when auxiliary switch is specified. VDE Certification on auxiliary switch codes 0, 2, 3 & 4 only.
5 Voltage Trip Coils are not rated for continuous duty. Available only with Frequency & Delay Codes 10 & 20.
6 Frequency & Delay Codes 92, 94 & 96 are not VDE Certified.
7 Current Ratings under 0.100 amps are not VDE Certified.
8 An Anti-Flash Over Barrier is supplied between poles on multi-pole units with 10-32 Stud (Terminal Code 1) or 1/4-20 Stud (Code 2) terminals per UL requirement.
9 Box Wire Connector will accept #14 through 0 AWG. copper wire or #12 through 0 AWG. aluminum wire.
10 Box Wire Connector with Pressure Plate for stranded wire, consult factory for details.
11 Back Mounted breakers can also be front mounted by utilizing the proper front panel mounting inserts normally supplied. However, terminal connections must be made prior to mounting.
12 VDE Certification requires dual (I-O, ON-OFF) markings on all handles.
13 Not available with VDE Certification.

Circuit & Terminal Diagrams: in. [mm]

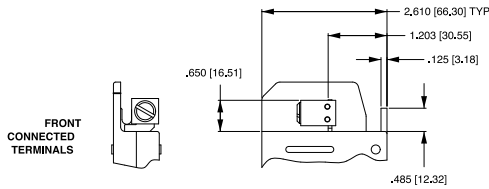
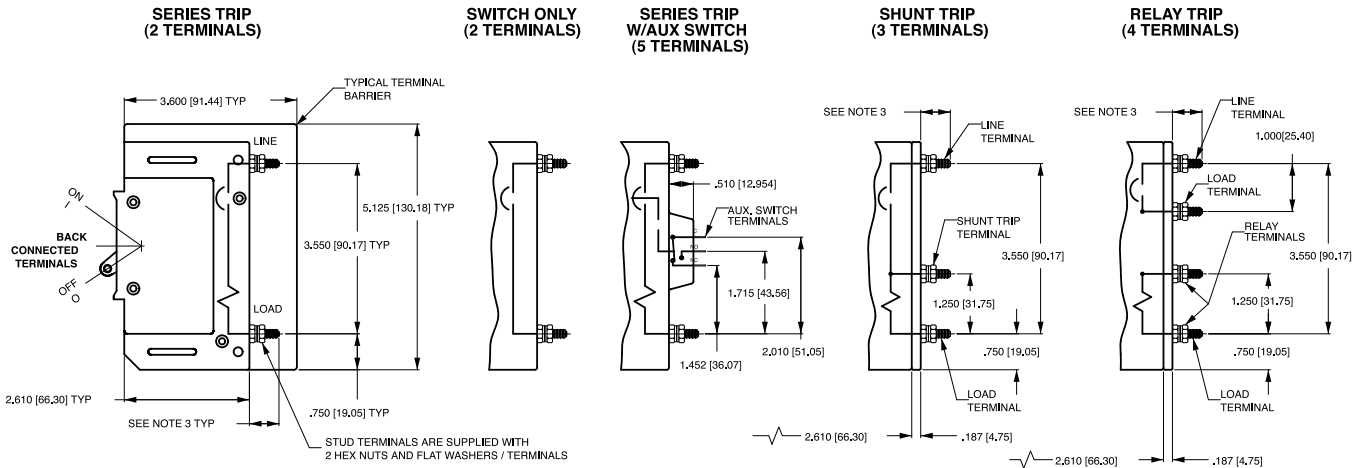

BOX TYPE WIRE CONNECTORS

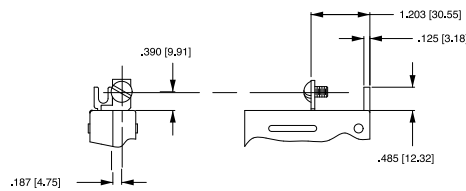

BUS TYPE SCREW TERMINALS

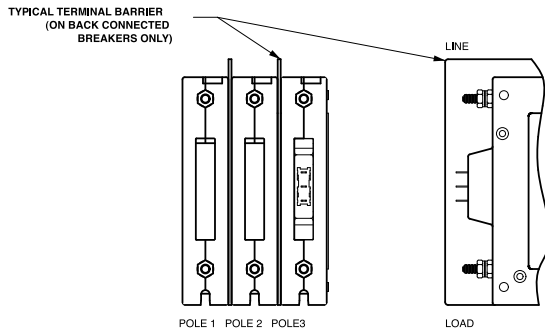

MULTI-POLE IDENTIFICATION SCHEME

AUXILIARY SWITCH TERMINALS

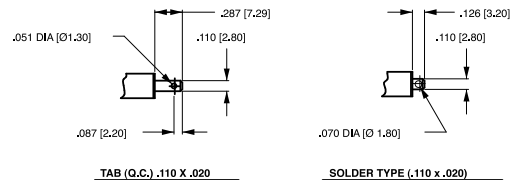

TABLE A TIGHTENING TORQUE SPECIFICATIONS		
THREAD SIZE TERMINAL TYPE	WIRE SIZE	TORQUE
#6-32 (M3) HARDWARE	—	7-9 IN-LBS (0.8-1.0 NM)
#10-32 THD TERMINAL SCREW	ALL	15-20 IN-LBS (1.7-2.3 NM)
1/4-20 THD TERMINAL SCREW	ALL	30-35 IN-LBS (3.4-4.0 NM)
#10-32 STUDS	ALL	15-20 IN-LBS (1.7-2.3 NM)
1/4-20 STUDS	ALL	30-35 IN-LBS (3.4-4.0 NM)
BOX WIRE CONNECTOR	14-10 AWG	35 IN-LBS (4.0 NM)
	8 AWG	40 IN-LBS (4.5 NM)
	6-4 AWG	45 IN-LBS (5.1 NM)
	3-10 AWG	50 IN-LBS (5.7 NM)

Notes:

- All dimensions are in inches [millimeters].
- Tolerance ± 0.020 [.51] unless otherwise specified.
- 0-50 amps: 10-32 & M5 Studs .625 \pm .062/15.88 \pm 1.574 long.
- 51-120 amps: 1/4-20 & M6 Studs .750 \pm .062/19.05 \pm 1.574 long.

Dimensional Specifications: in. [mm]

MOUNTING INSERTS:

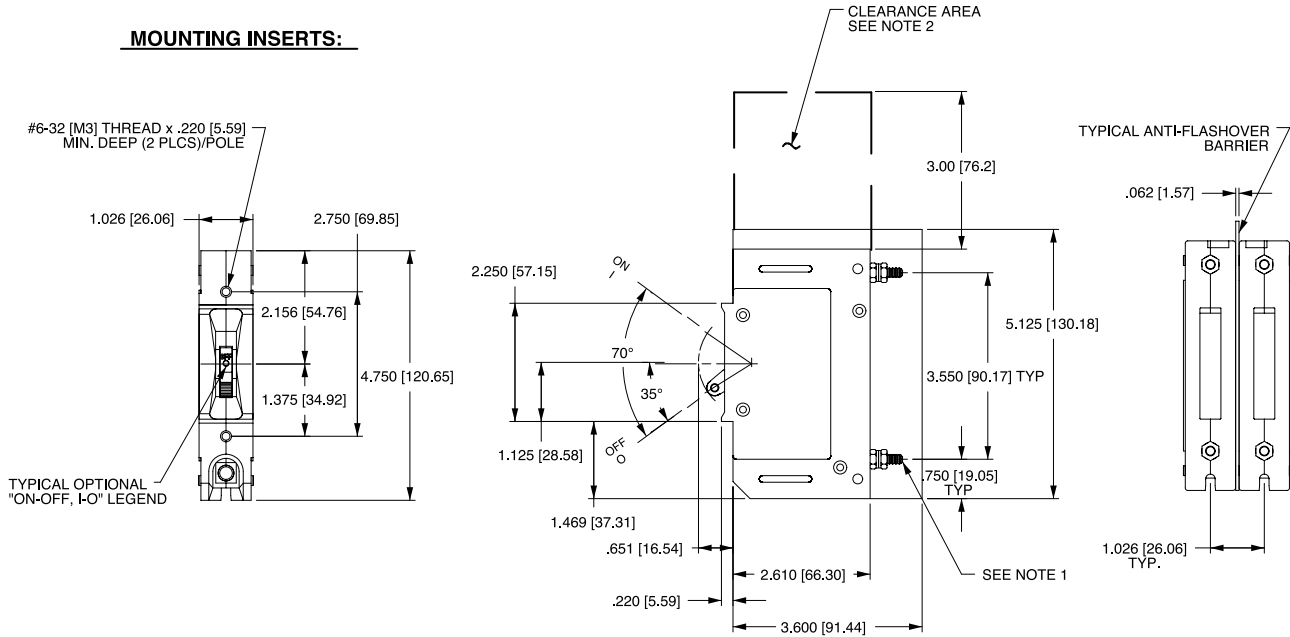

PANEL CUTOUT DETAIL

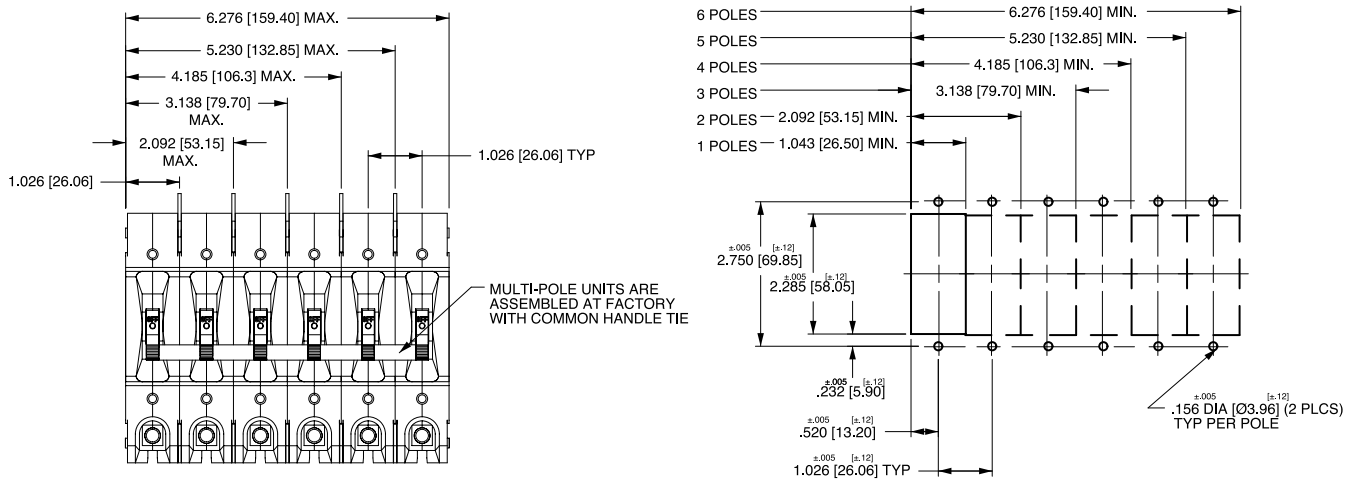

Notes:

- 1 1/4 -20 stud terminal in Series Trip circuit configuration shown.
- 2 A 3" min spacing must be provided between the circuit breaker arc venting area of back connected E-Series circuit breaker and grounded obstructions.
- 3 All dimensions are in inches [millimeters].
- 4 Tolerance ±.020 [5.1] unless otherwise specified.
- 5 Circuit breakers must be mounted on vertical surface.

Dimensional Specifications: in. [mm]

MOUNTING INSERTS:

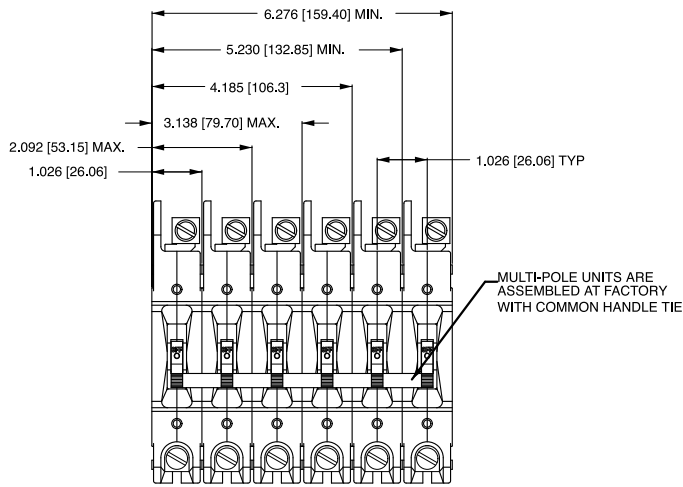
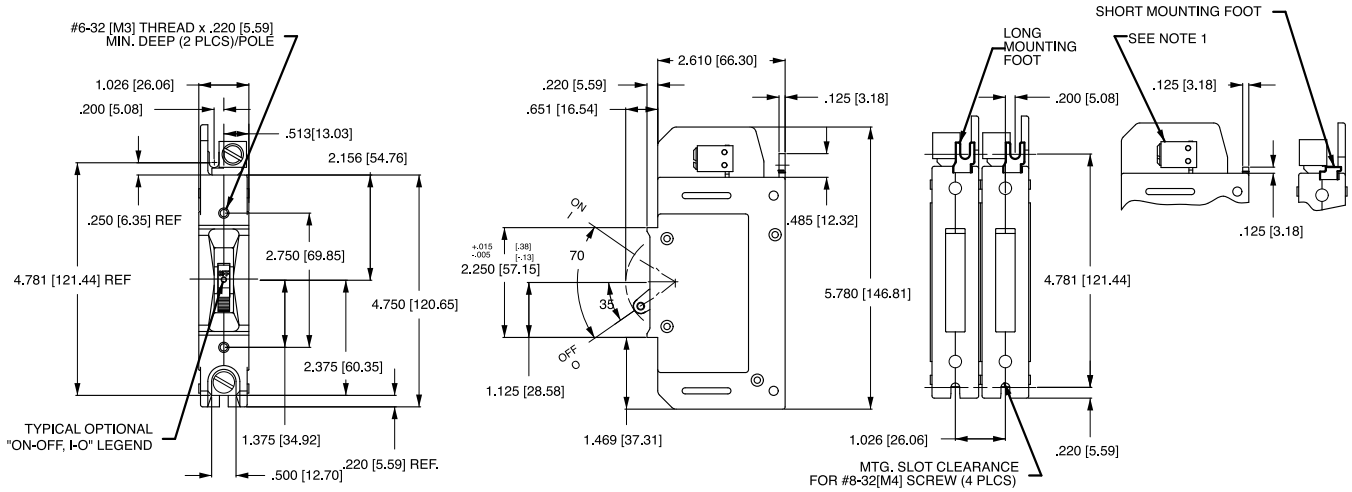

PANEL CUTOUT DETAIL

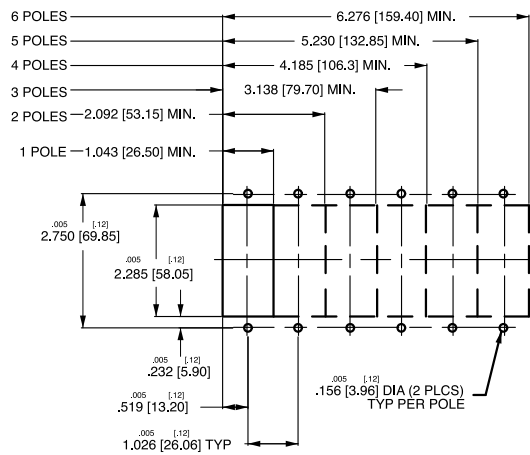

Notes:

- 1 All dimensions are in inches [millimeters].
- 2 Tolerance ± 0.020 [.51] unless otherwise specified.
- 3 Box wire connector terminal in Series Trip circuit configuration shown.
- 4 Circuit breakers must be mounted on vertical surface.

F-Series

F-Series

CIRCUIT BREAKER

The F-Series hydraulic-magnetic high amperage circuit breakers are designed to handle high current applications in extremely hot and/or cold locations. Due to its time-proven hydraulic-magnetic design, the F-Series load sensing mechanism is insensitive to changes in ambient or enclosure temperature, providing a consistent trip point over temperatures ranging from -40°C to $+85^{\circ}\text{C}$. Additionally, the F-Series circuit breakers come with a choice of overload time delays, making them ideal for critical applications having inductive loads.

Further, the F-Series breakers are available up to 700A and an optional 25 millivolt metering shunt construction provides a safe method for monitoring current flowing through the breaker by simply connecting a meter with light gauge wire to the appropriate terminals located on the shunt housing at the rear of the breaker. Applications can be customized by measuring and displaying percentage of current, watts or safe/danger zones.

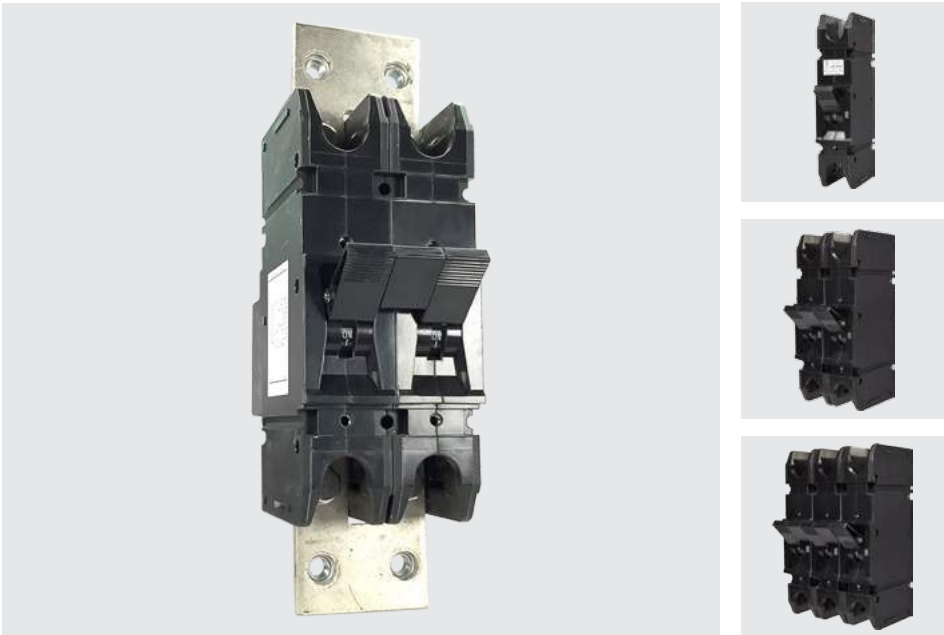

Product Highlights:

- ♦ AC ratings to UL 489
- ♦ DC voltage ratings up to 700A with metering shunt section
- ♦ Consistent trip point over temperatures ranging from -40°C to $+85^{\circ}\text{C}$
- ♦ Optional 25 millivolt metering shunt construction

Electrical

Maximum Voltage 125VDC, 277VAC
 Current Ratings Standard current coils: 100, 125, 150, 175, 225, 250 amps. 300, 350, 400, 500, 600, 700 amps available as parallel pole construction.
 Auxiliary Switch Rating SPDT; 10.1 Amps @ 250VAC, 1.0 Amps @ 65VDC, 0.5 Amps @ 80VDC 0.1 Amps @ 125VAC (with gold contacts).
 Insulation Resistance Minimum: 100 Megohms at 500 VDC
 Dielectric Strength 1960 VAC, 50/60 Hz for one minute between all electrically isolated terminals, except 2500 VAC for one minute between alarm/aux. switch and main terminals with contacts in open and closed position. F-Series circuit breakers comply with the 8mm spacing & 3750VAC 50/60 Hz dielectric requirements from hazardous voltage to operator accessible surfaces, between adjacent poles and from main circuits to auxiliary circuits per Publications EN 60950 and VDE 0805.
 Resistance, Impedance Values from Line to Load Terminal - based on Series Trip Circuit Breaker.

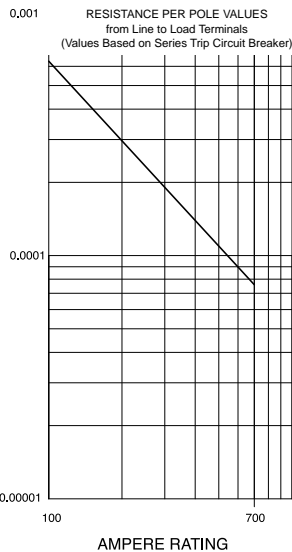

CURRENT (AMPS)	TOLERANCE (%)
100 - 700	50

Mechanical

Endurance 4000 ON-OFF operations with rated Current & Voltage & 4000 operations with no load (8000 operations total) @ 5 per minute. Parallel Pole construction: 1000 operations with rated Current and Voltage @ 5 per minute.
 Trip Free All F-Series Circuit Breakers will trip on overload, even when the actuator is forcibly held in the ON position.
 Trip Indication The operating actuator moves positively to the OFF position when an overload causes the circuit breaker to trip.

Physical

Number of Poles 1 - 3 Poles Note: Ratings over 250 Amps only available with parallel pole.
 Internal Circuit Config. Series (with or without auxiliary switch), Switch Only (with or without auxiliary switch).
 Available Accessories Factory installed: DC Current Metering Shunt (25 mV @Ir)
 Weight Varies depending on construction. Consult factory.
 Standard Colors Housing - Black; Actuator- Black or White with contrasting ON-OFF legend.

Environmental

Designed and tested in accordance with requirements of specification MIL-PRF-55629 & MIL-STD-202 as follows:
 Shock Withstands 100 Gs, 6ms, sawtooth while carrying rated current per Method 213, Test Condition "I". Instantaneous and ultra-short curves tested @ 90% of rated current.
 Vibration Withstands 0.060" excursion from 10-55 Hz, and 10 Gs 55-500 Hz, at rated current per Method 204C, Test Condition A. Instantaneous and ultrashort curves tested at 90% of rated current.
 Moisture Resistance Method 106D; ten 24-hour cycles @ + 25°C to +65°C, 80-98% RH.56 days @ +85°C, 85% RH.
 Salt Spray Method 101, Condition A (90-95% RH @ 5% NaCl Solution, 96 hrs).
 Thermal Shock Method 107D, Condition A (Five cycles @ -55°C to +25°C to +85°C to +25°C).
 Operating Temperature -40° C to +85° C

*Manufacturer reserves the right to change product specification without prior notice.

Electrical Tables

Table A: Lists UL Listed (489) and CSA Certified (C22.2 N0. 5.1-M) configurations and performance capabilities as a Molded Case Circuit Breaker

F SERIES TABLE A : UL489 LISTED BRANCH CIRCUIT BREAKERS						
CIRCUIT CONFIGURATION	VOLTAGE			CURRENT RATING FULL LOAD AMPS	INTERRUPTING CAPACITY (AMPS)	
	MAX RATING	FREQUENCY	PHASE		UL / CSA 1 - 3 POLES	TUV ² 1 or 2 POLES
SERIES	125	DC	---	50 - 250	50,000	25,000
	120 / 240 ¹	50 / 60	1	100 - 250	10,000	---
	277	50 / 60	1	100 - 250	10,000	---
	208Y / 120	50 / 60	3	100 - 250	10,000	---

Notes:
 1 120/240V rating available in 2 or 3 poles. In a 3 pole construction the center pole is Neutral.
 2 TUV constructions are not available with AC ratings and 150-250 amp ratings only.

Table B: Lists UL Listed configurations and performance capabilities as Circuit Breakers for use in Communications Equipment (Guide DITT, File E189195), under UL489A

F-SERIES TABLE B : UL489 LISTED BRANCH CIRCUIT BREAKERS				
CIRCUIT CONFIGURATION	VOLTAGE		CURRENT RATING FULL LOAD AMPS	INTERRUPTING CAPACITY (AMPS) WITHOUT BACKUP FUSE
	MAX. RATING	FREQUENCY		
SERIES	125	DC	251 - 700	50,000

Agency Certifications

UL Listed

UL 489



Circuit Breakers , Molded Case (Guide DIVQ, File E129899) Complies with the requirements of the CSA Standard for Molded Case Circuit Breakers,

UL 489A



CANCSA- C22.2 No. 5.1 -M Circuit Breakers for Use in Communications Equipment (Guide DITT, File E189195)

TUV Certified



IEC 60947-2

Low Voltage Switchgear and Control Gear under TUV License No. R72031058

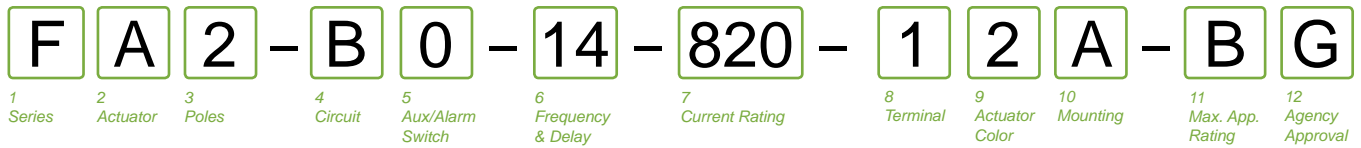

1 SERIES

F

2 ACTUATOR

A Handle, one per pole
S Mid-Trip Handle, one per pole
T Mid-Trip Handle, one per pole & Alarm Switch

3 POLES

1 One **2** Two **3** Three

4 CIRCUIT

A¹ Switch Only (no coil)
S Series Trip (current)
C² Series Trip (voltage)

Parallel Pole Construction:

M^{3,4} Series Trip (Current) with Metering Shunt
N^{3,4} Switch Only with Metering Shunt
P³ Series Trip (Current)
Q³ Switch Only

5 AUXILIARY SWITCH⁵

0 without Auxiliary Switch
2 S.P.D.T. 0.110 Q.C. Terminals
3 S.P.D.T. 0.139 Solder Lug
4 S.P.D.T. 0.110 Q.C. Terminals (Gold Contacts)
5 S.P.S.T., 0.093 Q.C. Terminals (Gold Contacts)
6 S.P.S.T. 0.110 Q.C. Terminals

7 S.P.S.T. 0.110 Q.C. Terminals (Gold Contacts)
8 S.P.S.T. 0.187 Q.C. Terminals
9 S.P.D.T. 0.187 Q.C. Terminals
A⁶ S.P.S.T., 0.093 Round QC Terminals
B⁶ S.P.D.T., 0.093 Round QC Terminals

6 FREQUENCY & DELAY

03 DC 50/60Hz, Switch Only
10⁷ DC Instantaneous
11 DC Ultra Short
12 DC Short

14 DC Medium
16 DC Long
22 AC Short
24 AC Medium
26 AC Long

7 CURRENT RATING (AMPERES)

CODE AMPERES

810 100.000	820 200.00	835 ⁸ 350.00	860 ⁸ 600.00
912 125.00	922 225.00	840 ⁸ 400.00	870 ⁸ 700.00
815 150.00	825 250.00	845 ⁸ 450.00	
917 175.00	830 ⁸ 300.00	850 ⁸ 500.00	

OR VOLTAGE COIL (MIN. TRIP RATING, VOLTS)⁷

CODE AMPERES

A06 6 DC, 5 DC	A24 24 DC, 20 DC	A65 65 DC, 55 DC
A12 12 DC, 10 DC	A32 32 DC, 25 DC	B25 125 DC, 100 DC
A18 18 DC, 15 DC	A48 48 DC, 40 DC	J06 6 AC, 5 AC

8 TERMINAL

		Max Rating
Back Connected (Front Mounted Only)		
1 ⁹	3/8-16 Stud	250A
2 ¹⁴	3/8-16 Screw, Line & Load	700A
5 ¹⁴	3/8-16 Short Stud	250A
Front Connected (Back Mounted Only)¹¹		Max Rating
3	Box Wire Connector, Line & Load	700A
4 ¹⁴	3/8-16 Screw, Line & Load	700A

9 ACTUATOR COLOR & LEGEND^{12,13}

Actuator Color	I-O	ON-OFF	Dual	Marking Color
White	A	B	1	Black
Black	C	D	2	White

10 MOUNTING

Front Mounting Inserts

A 10-32
B ISO M5

Back Mounting Inserts

10-32 screw clearance holes
 10-32 screw clearance holes

11 MAXIMUM APPLICATION RATING

	VOLTAGE	CURRENT
B	125 VDC	700A
C ¹⁵	120/240	250A
F	277 VAC	250A
7 ¹⁶	120/208 VAC	250A

12 AGENCY APPROVAL

A No approvals
G UL489 Listed & CUL Certified
J UL489 Listed, CUL Certified & TUV Certified
T UL489A (Telecom) Listed

Notes:

- For 100 to 250 amps, select Current Code 825. For 300-400 amps, select Current Code 840. For 450-700 amps, select Current Code 870.
- Available with Frequency and Delay code 10 or 20 only, and are not rated for continuous duty. Delay 10 and 20 are only available with voltage coils.
- 3 Codes M, N, P & Q (Parallel Poles) are supplied with factory installed Bus Bar on Line and Load.
- 4 Metering terminals are female pin type, ref. Molex part number 02-09-1101, model 1189-T.
- Auxiliary Switch breakers are only available with Series Trip and Switch Only circuits. On multi-pole breakers, one Auxiliary Switch is supplied, mounted in the extreme right pole per figure A. Back-Mounted breakers require special mounting provisions when an Auxiliary Switch is specified.
- Available with parallel pole construction (circuit codes P and Q, and breakers with circuit codes M and N).
- Frequency and delay code 10 is only available with Voltage Coils. Voltage Coils are not rated for continuous duty.
- Ratings over 250 amps are only available with Agency Approval code T (UL489A) and are Parallel Pole configuration (circuit codes M, N, P and Q.) 300-450 amp ratings are available on two pole breakers. 500-700 amp ratings are available on three pole breakers.
- Per UL requirement, an "Anti-Flash Over Barrier" is supplied between poles on multipole breakers with 3/8 - 16 stud terminals (Terminal Code 1) on AC rated breakers only.
- Front connected breakers can also be front mounted by utilizing the supplied front panel mounting inserts. Terminal connections must be made before mounting.
- Box Wire connector will accept #6 through 250 MCM copper wire.
- Agency codes G & T must have ON-OFF or dual legends. Agency code J must have dual legend.
- Other colors available. Consult factory.
- Terminals 2, 4 & 5 are shipped without terminal hardware.
- 2 or 3 Pole Circuit Breaker Required for 120/240 VAC Rating.
- 3 Pole Circuit Breaker Required for 120/208 VAC Rating.

Circuit & Terminal Diagrams: in. [mm]

F SERIES NON-PARALLEL POLE CONSTRUCTION:

CIRCUIT BREAKER PROFILE	CIRCUIT SCHEMATIC		CIRCUIT CODE	AUX. SWITCH CODE	CIRCUIT SCHEMATIC		CIRCUIT CODE	AUX. SWITCH CODE
	ANSI	IEC			ANSI	IEC		
<p>2.965 [75.31] 1.328 [33.73] 5.991 [152.17] LOAD</p>	<p>SWITCH ONLY (NO COIL)</p>	<p>IEC</p>	A	0	<p>SWITCH TRIP</p>	<p>IEC</p>	BC	0
<p>LINE 2.733 [69.41] .222 [5.63] 2.496 [63.39] LOAD 2.091 [53.11]</p>	<p>SWITCH ONLY (NO COIL) WITH AUXILIARY SWITCH</p>	<p>IEC</p>	A	2 3 4 5 9	<p>SERIES TRIP WITH AUXILIARY SWITCH</p>	<p>IEC</p>	BC	2 3 4 5 9

TERMINAL DETAILS BACK CONNECT

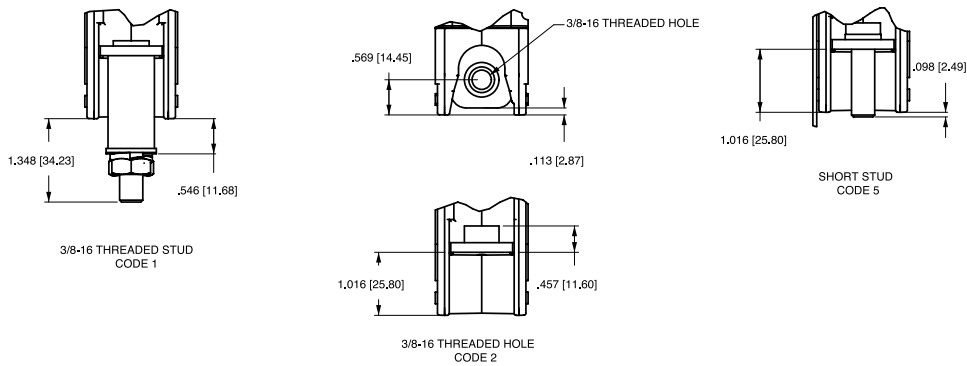

FRONT CONNECT

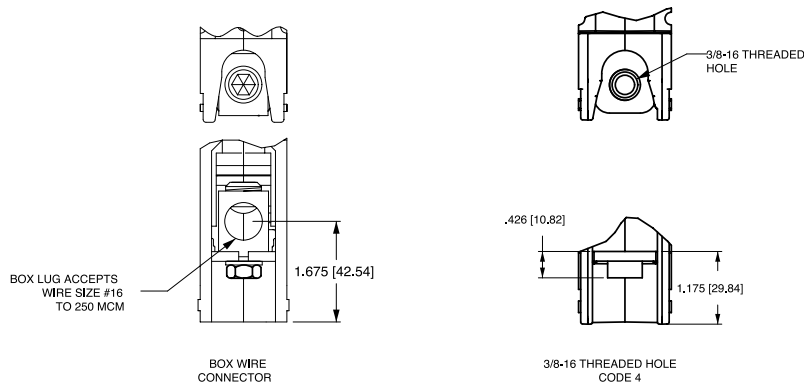

Notes:

- All dimensions are in inches [millimeters].
- Tolerance $\pm .020$ [.51] unless otherwise specified.

Circuit & Terminal Diagrams: in. [mm]

F-SERIES PARALLEL POLE CONSTRUCTION:

CIRCUIT BREAKER PROFILE	CIRCUIT SCHEMATIC		CIRCUIT CODE	AUX SWITCH CODE	CIRCUIT SCHEMATIC		CIRCUIT CODE	AUX SWITCH CODE
	ANSI	IEC			ANSI	IEC		
<p>SERIES TRIP (2 TERMS.)</p>	<p>SWITCH ONLY (NO COIL)</p>		A	0	<p>SERIES TRIP</p>		BC	0
<p>SERIES TRIP W/AUX. SWITCH (5 TERMS.)</p>	<p>SWITCH ONLY (NO COIL) WITH ALARM OR AUX. SWITCH</p>		A	B	<p>SERIES TRIP WITH ALARM OR AUX. SWITCH</p>		BC	B
<p>SERIES TRIP W/METERING SHUNT (4 TERMS.)</p> <p>(FOR 100-225 AMPS DIM = 2.000)</p>	<p>SWITCH ONLY (NO COIL) WITH METERING SHUNT</p>		N	0	<p>SERIES TRIP CURRENT COIL WITH METERING SHUNT</p>		M	0
<p>RELAY TRIP (4 TERMS.)</p>	<p>SWITCH ONLY WITH ALARM OR AUX. SWITCH AND METERING SHUNT</p>		N	A	<p>SERIES TRIP WITH ALARM OR AUX. SWITCH AND METERING SHUNT</p>		M	A

- Notes:
- 1 All dimensions are in inches [millimeters].
 - 2 Tolerance ± 0.020 [.51] unless otherwise specified.

Dimensional Specifications: in. [mm]

SERIES TRIP BACK CONNECT (STUD TERMINALS SHOWN)

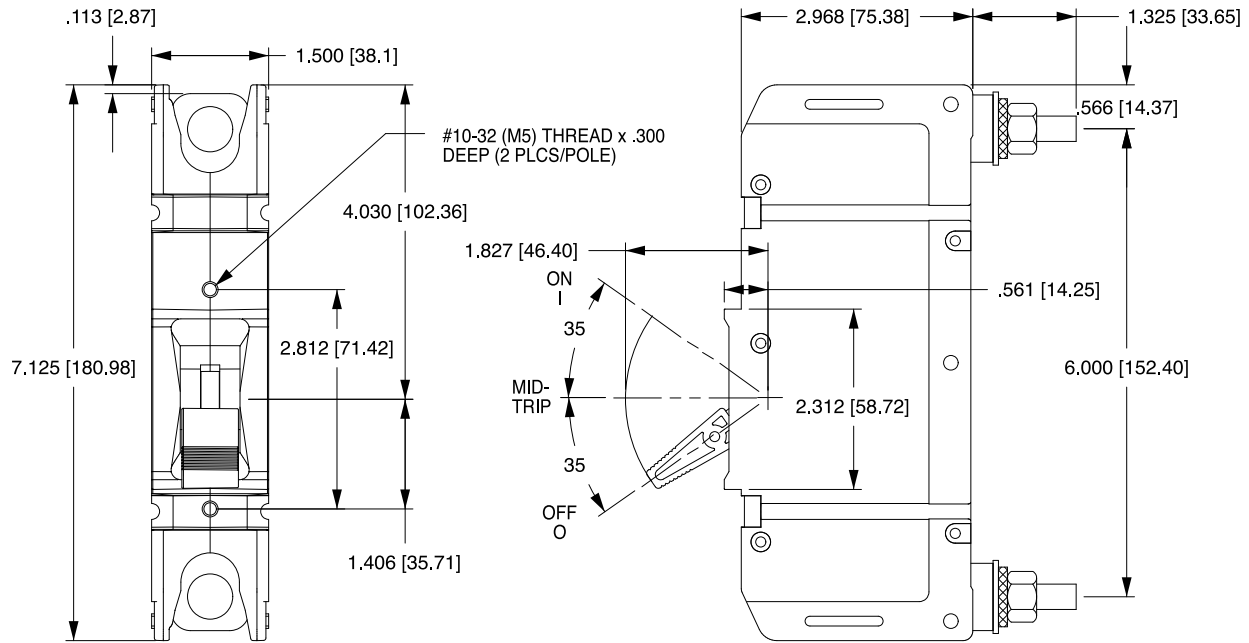

MULTIPOLE SERIES TRIP, SHOWING TERMINAL BARRIER

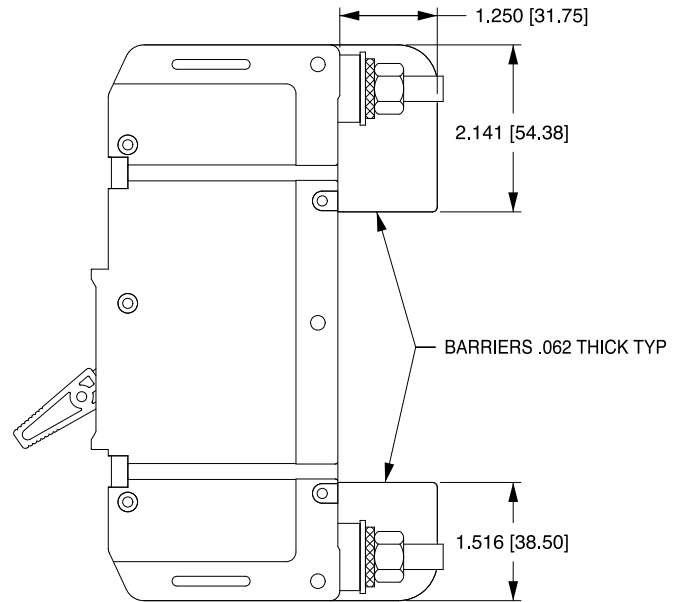
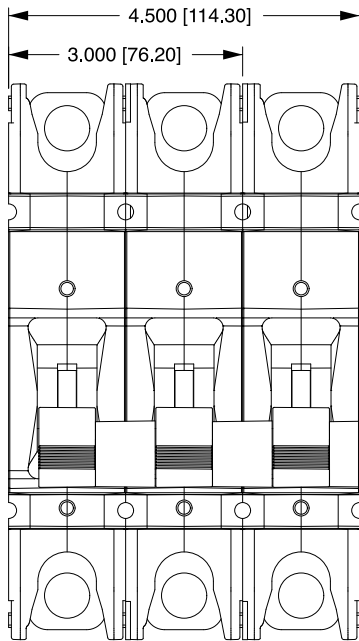

Notes:

- 1 All dimensions are in inches [millimeters].
- 2 Tolerance ± 0.020 [51] unless otherwise specified.

Dimensional Specifications: in. [mm]

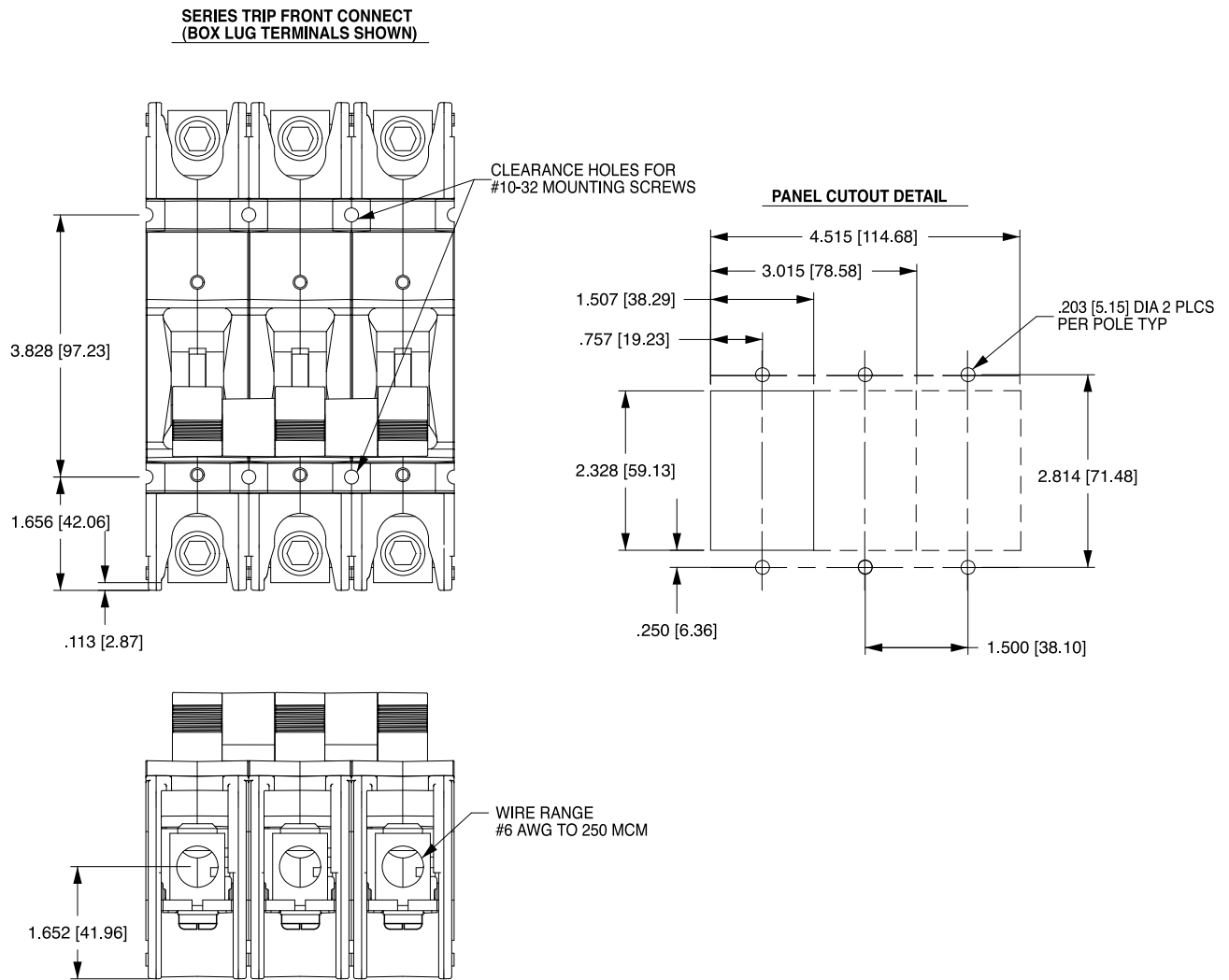

Notes:

- 1 All dimensions are in inches [millimeters].
- 2 Tolerance ± 0.020 [.51] unless otherwise specified.

Dimensional Specifications: in. [mm]

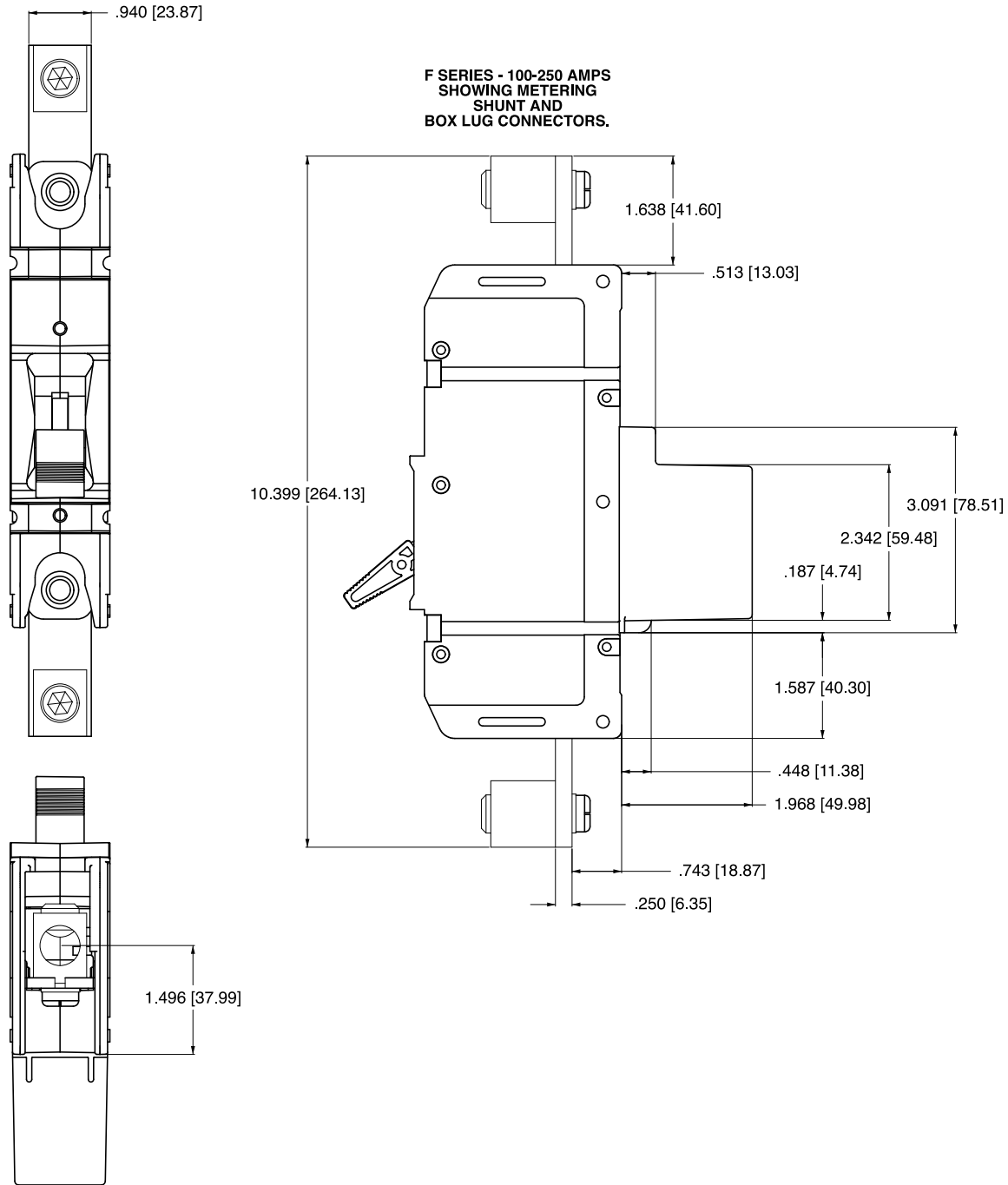

F-Series breakers are available up to 700A, and are also available with a 25 millivolt metering shunt construction. This optional construction provides a safe method for monitoring current flowing through the breaker by simply connecting a meter with light gauge wire to the appropriate terminals located on the shunt housing at the rear of the breaker. You can customize the application by measuring and displaying percentage of current, watts or safe/danger zones.

Notes:

- 1 All dimensions are in inches [millimeters].
- 2 Tolerance ± 0.020 [.51] unless otherwise specified.

Dimensional Specifications: in. [mm]

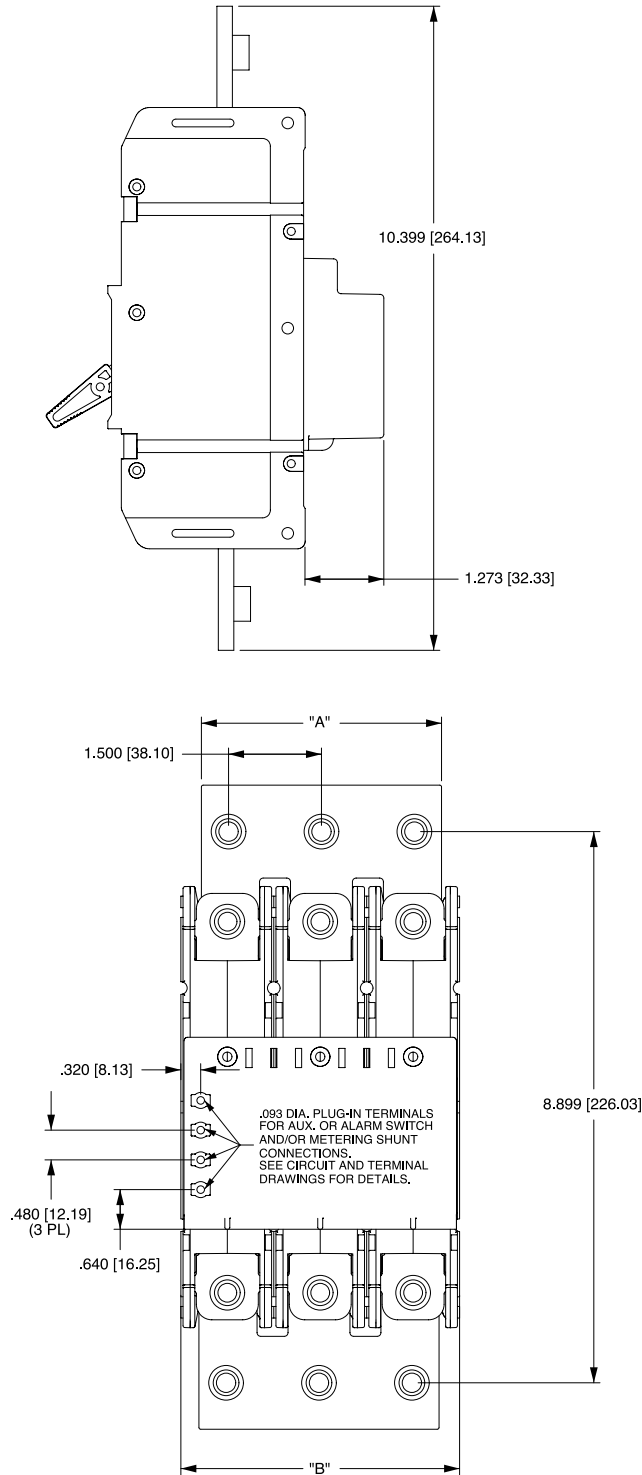

**F-SERIES PARALLEL POLE 250-700 AMPS
SHOWING FRONT CONNECT SCREW TERMINALS**

- Notes:
- 1 All dimensions are in inches [millimeters].
 - 2 Tolerance ± 0.020 [.51] unless otherwise specified.

A, B, C, CX, D, G, H, L, N-SERIES TIME VALUES											
TRIP TIME (SECONDS)	PERCENT OF RATED CURRENT										
	DELAY	100%	125%	135%	150%	200%	400%	600%	800%	1000%	1200%
10	No Trip	May Trip	---	.032 MAX	.024 MAX	.020 MAX	.018 MAX	.016 MAX	.015 MAX	.013 MAX	.013 MAX
11	No Trip	.013 - .125	---	.010 - .070	.008 - .032	.006 - .020	.005 - .020	.004 - .020	.004 - .020	.004 - .020	.004 - .020
12	No Trip	.500 - 6.50	---	.300 - 3.00	.130 - 1.20	.031 - .220	.011 - .120	.004 - .090	.004 - .060	.004 - .040	.004 - .040
14	No Trip	2.00 - 60.0	---	1.20 - 40.0	.600 - 20.0	.150 - 3.00	.030 - 1.30	.004 - .600	.004 - .100	.004 - .100	.004 - .100
16	No Trip	45.0 - 345	---	20.0 - 150	9.00 - 60.0	1.40 - 11.4	.150 - 5.80	.009 - 3.70	.005 - 1.70	.005 - .500	.005 - .500
20	No Trip	May Trip	---	.040 MAX	.035 MAX	.030 MAX	.025 MAX	.020 MAX	.017 MAX	.015 MAX	.015 MAX
21	No Trip	.014 - .150	---	.011 - .095	.008 - .055	.006 - .035	.005 - .027	.005 - .021	.004 - .018	.004 - .017	.004 - .017
22	No Trip	.700 - 12.0	---	.350 - 4.00	.130 - 1.30	.027 - .220	.008 - .130	.004 - .090	.004 - .045	.004 - .040	.004 - .040
24	No Trip	10.0 - 160	---	6.00 - 60.0	2.20 - 20.0	.300 - 3.00	.050 - 1.30	.007 - .500	.005 - .060	.005 - .040	.005 - .040
26	No Trip	50.0 - 700	---	32.0 - 350	10.0 - 90.0	1.50 - 15.0	.500 - 7.00	.020 - 3.00	.006 - 2.00	.005 - 1.00	.005 - 1.00
32	No Trip	May Trip	.400 - 8.00	.300 - 4.00	.130 - 1.30	.027 - .220	.008 - .130	.004 - .090	.004 - .060	.004 - .040	.004 - .040
34	No Trip	May Trip	1.80 - 100	1.20 - 60.0	.600 - 20.0	.150 - 3.00	.030 - 1.30	.004 - .600	.004 - .110	.004 - .100	.004 - .100
36	No Trip	May Trip	35.0 - 520	20.0 - 350	9.00 - 90.0	1.40 - 15.0	.150 - 7.00	.009 - 3.70	.005 - 2.00	.004 - 1.00	.004 - 1.00
42	No Trip	.700 - 12.0	---	.400 - 6.00	.180 - 2.30	.050 - .600	.026 - .300	.018 - .200	.014 - .150	.012 - .130	.012 - .130
44	No Trip	7.00 - 100	---	3.00 - 50.0	1.10 - 18.0	.220 - 3.00	.120 - 1.70	.075 - 1.20	.050 - .850	.042 - .720	.042 - .720
46	No Trip	50.0 - 700	---	31.0 - 350	12.0 - 150	1.50 - 20.0	.700 - 10.0	.404 - 7.90	.260 - 6.50	.198 - 5.80	.198 - 5.80
52	No Trip	.500 - 6.50	---	.340 - 4.50	.180 - 2.30	.051 - .600	.030 - .320	.018 - .220	.014 - .200	.012 - .130	.012 - .130
54	No Trip	1.50 - 50.0	---	.750 - 35.0	.350 - 18.0	.110 - 3.00	.070 - 1.70	.045 - 1.40	.039 - 1.30	.035 - 1.30	.035 - 1.30
56	No Trip	45.0 - 345	---	19.0 - 170	8.50 - 100	1.24 - 15.0	.410 - 9.00	.256 - 8.00	.210 - 5.50	.198 - 2.90	.198 - 2.90

Notes:

UL489 C-Series Breakers available with Delay Curves 11, 12, 14, 16, 21, 22, 24, 26, 42, 44, 46.

Delay Curves 11,12,14,16,21,22,24,26,42,44,46,52,54,56: Breakers to hold 100% and must trip at 125% of rated current and greater within the time limit shown in this curve.

Delay Curves 32,34,36: Breakers to hold 100% and must trip at 135% of rated current and greater within the time limit shown in this curve.

Delay Curves 10,20: Breakers to hold 100% and must trip at 150% of rated current and greater within the time limit shown in this curve.

All Curves: Curve data shown represents breaker response at ambient temperature of 77°F (25°C) with no preloading. Breakers are mounted in standard wall-mount position.

On 50 amp and less current ratings, the minimum inrush pulse tolerance handling capability is 12 times the rated current on standard delays and 25 times the rated current on high inrush delays. These values are based on a 60 Hz 1/2 cycle, 8.33 ms pulse. High inrush delays should be specified for applications with high initial surge currents of short duration such as switching power supplies, highly capacitive loads and transformer loads.

AC

DC

Instantaneous

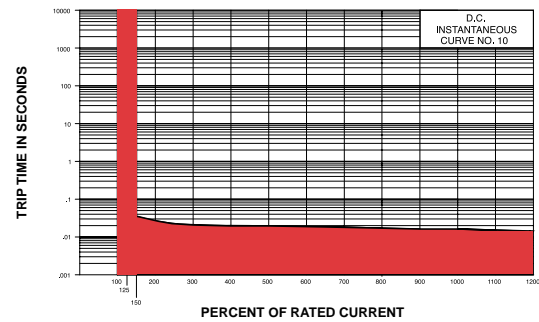
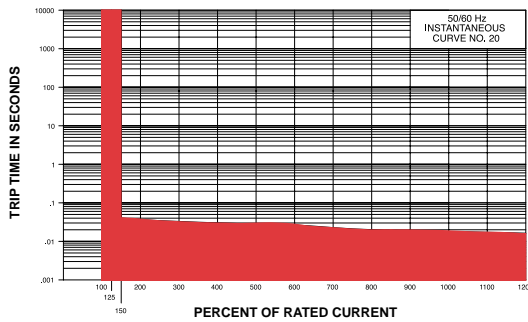

Ultrashort

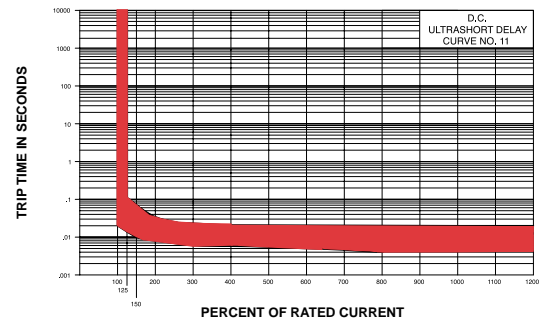
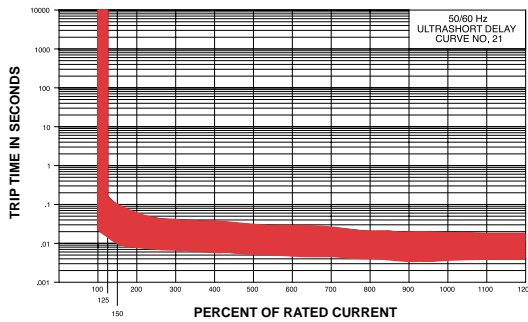

Short

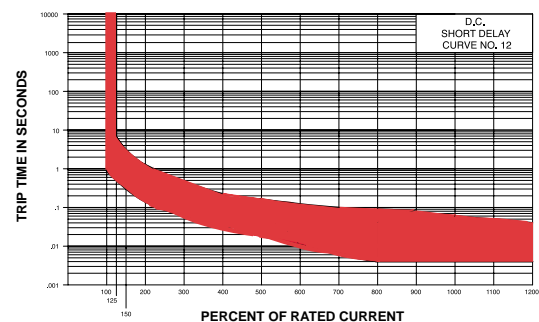
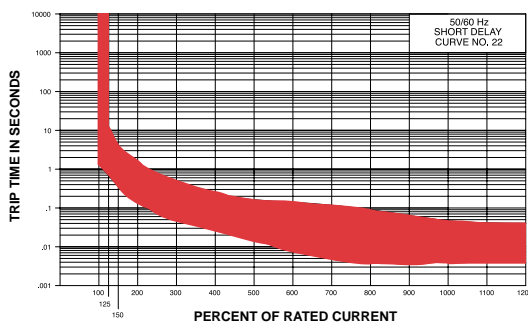

Medium

AC

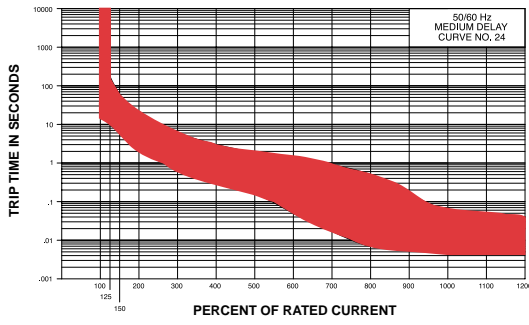

DC

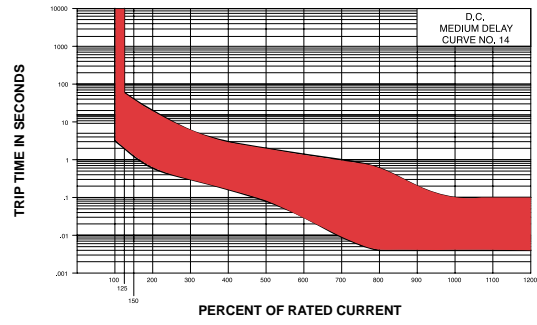

Long

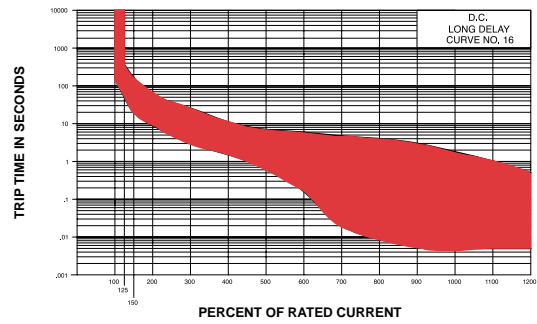
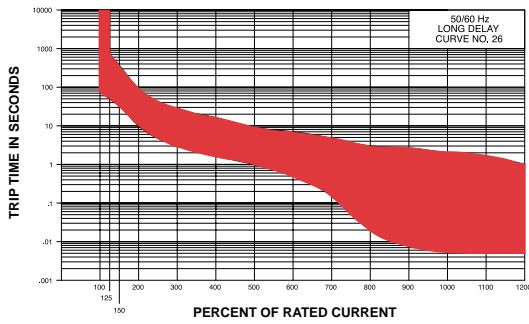

Short

High Inrush AC

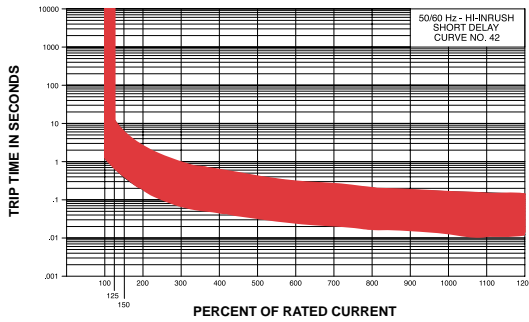

High Inrush DC

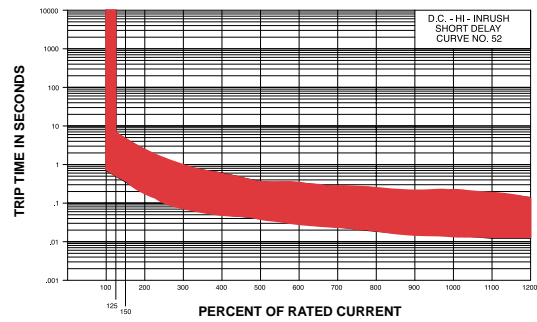

Medium

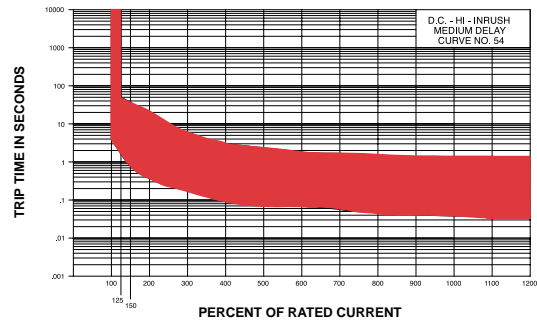
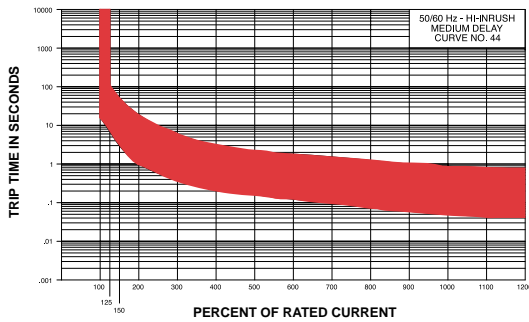

Long

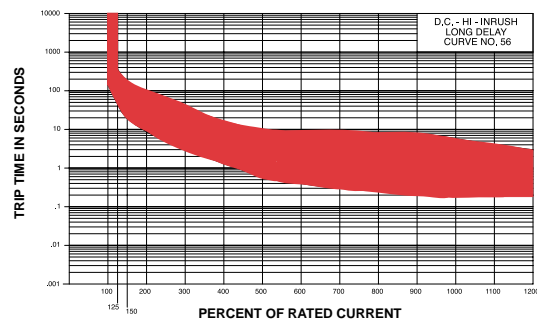
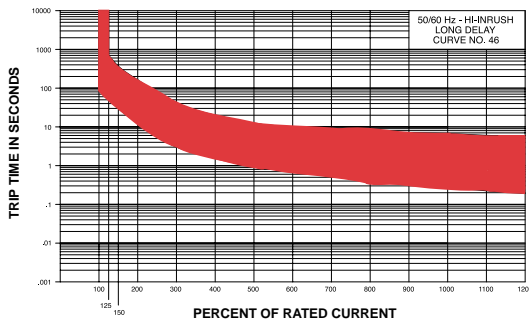

AC/DC

Short

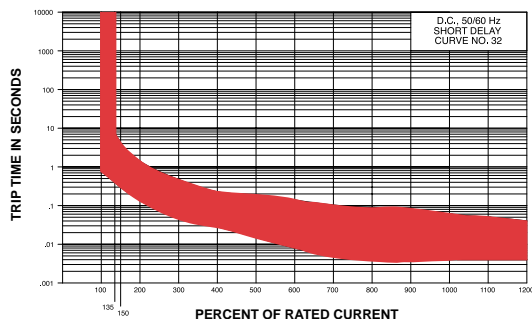

Medium

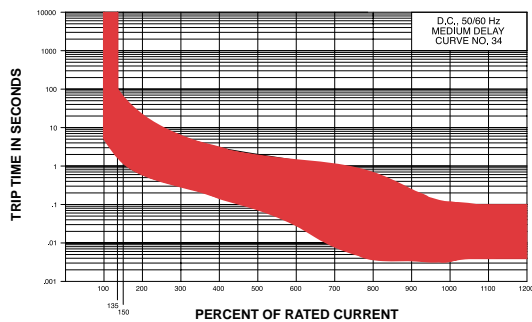

Long

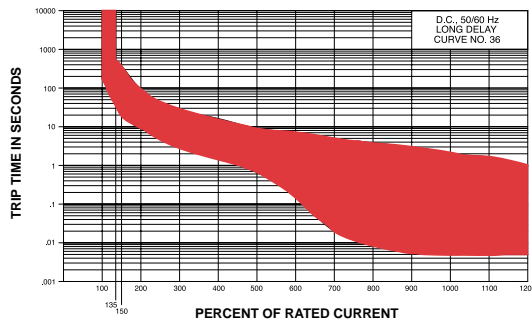

E-SERIES TIME DELAY VALUES											
TRIP TIME (SECONDS)	PERCENT OF RATED CURRENT										
	Delay	100%	125%	135%	150%	200%	400%	600%	800%	1000%	1200%
10	No Trip	May Trip	--	--	.001 - .038	.001 - .032	.001 - .021	.001 - .019	.001 - .019	.001 - .019	.001 - .019
12, 72	No Trip	.600 - 7.00	--	--	.330 - 2.00	.150 - .800	.033 - .160	.016 - .071	.010 - .048	.008 - .040	.008 - .040
14, 74	No Trip	11.0 - 110	--	--	6.00 - 45.0	3.00 - 18.0	.280 - 3.50	.013 - 1.50	.010 - .130	.009 - .090	.009 - .080
16, 76	No Trip	100 - 800	--	--	50.0 - 360	20.0 - 120	3.00 - 25.0	.020 - 11.0	.010 - .700	.009 - .230	.009 - .200
20	No Trip	May Trip	--	--	.001 - .040	.001 - .031	.001 - .020	.001 - .020	.001 - .020	.001 - .020	.001 - .020
22, 62	No Trip	.800 - 5.00	--	--	.400 - 2.30	.150 - .900	.034 - .170	.020 - .080	.012 - .051	.010 - .040	.009 - .040
24, 64	No Trip	7.20 - 90.0	--	--	4.40 - 35.0	2.00 - 15.0	.500 - 3.50	.025 - 1.60	.012 - .330	.010 - .070	.009 - .050
26, 66	No Trip	50.0 - 500	--	--	32.0 - 250	14.0 - 120	2.50 - 24.0	.320 - 7.00	.0125 - 3.10	.011 - .130	.010 - .055
30	No Trip	May Trip	--	--	.001 - .040	.001 - .032	.001 - .020	.001 - .020	.001 - .020	.001 - .020	.001 - .020
32, 92	No Trip	May Trip	.450 - 5.20	--	.330 - 2.30	.150 - .900	.033 - .170	.016 - .080	.009 - .051	.008 - .040	.008 - .040
34, 94	No Trip	May Trip	5.80 - 73.0	--	4.40 - 45.0	2.00 - 18.0	.280 - 3.60	.013 - 1.60	.010 - .330	.009 - .090	.009 - .080
36, 96	No Trip	May Trip	42.0 - 600	--	32.0 - 360	14.0 - 120	2.50 - 25.0	.020 - 11.0	.010 - 4.10	.009 - .330	.009 - .200

NOTES

Delay Curves 10,20,30: Breakers to hold 100% and must trip at 150% of rated current and greater within the time limit shown in these curves.
 Delay Curves 12,14,16,22,24,26,62,64,66,72,74,76: Breakers to hold 100% and must trip at 125% of rated current and greater within the time limit shown in these curves.
 Delay Curves 32,34,36,92,94,96: Breakers to hold 100% and must trip at 135% of rated current and greater within the time limit shown in these curves.
 All curves: Data shown represents breaker response at ambient temperature of 77°F (25°C) with no preloading. Breakers are mounted in standard wall-mount position.
 The minimum inrush pulse tolerance handling capacity on the above standard delays is 16 times rated current & 20 times rated current for high inrush delays based on a 60Hz 1/2 cycle, 8.33 ms pulse.

Instantaneous

AC

DC

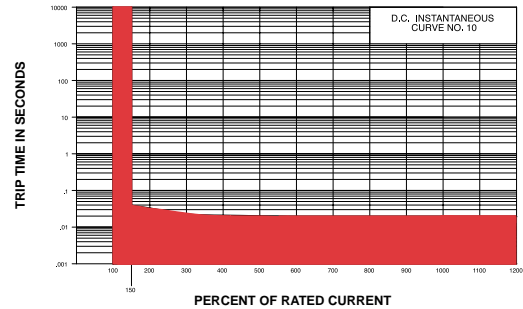
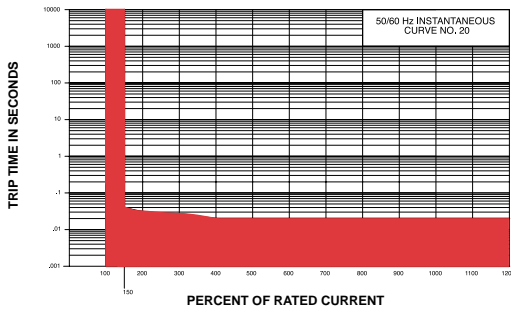

Short

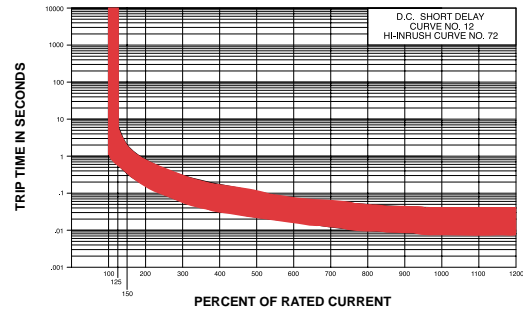
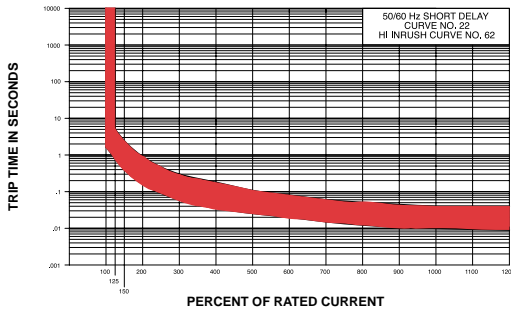

Medium

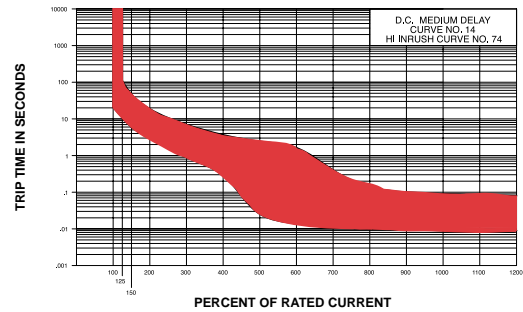
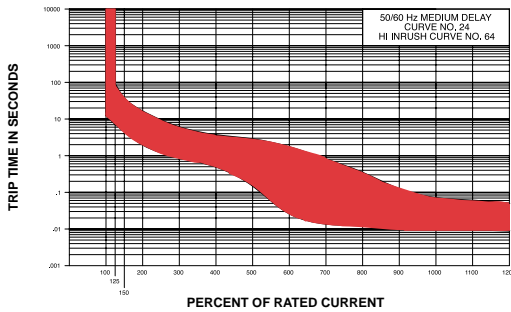

Long

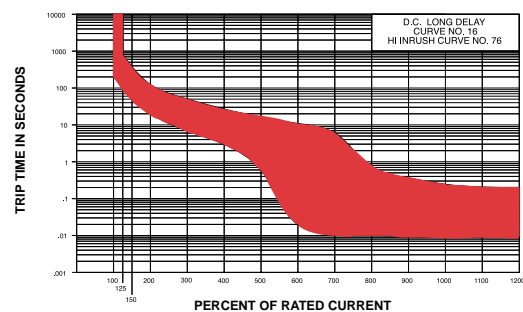
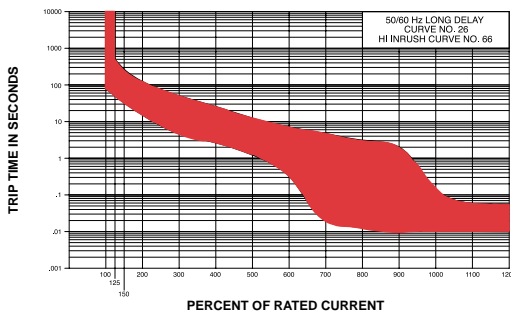

AC/DC

Instantaneous

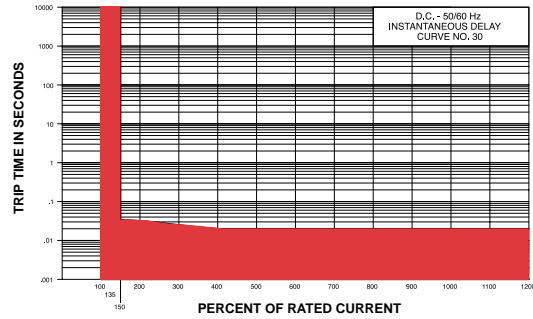

Short

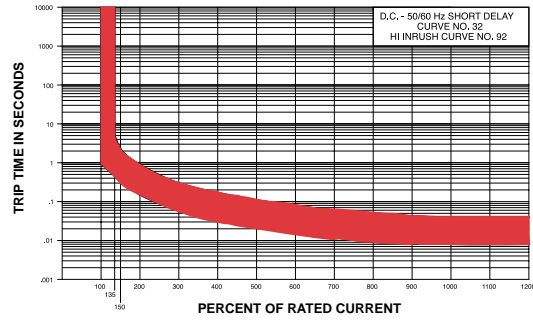

Medium

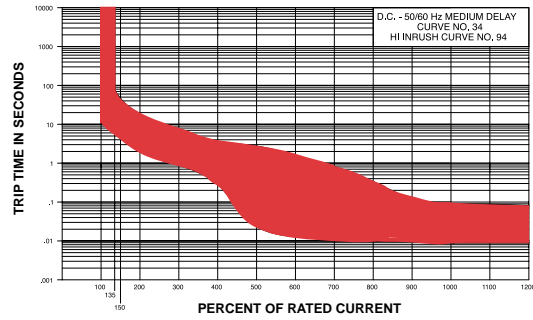

Long

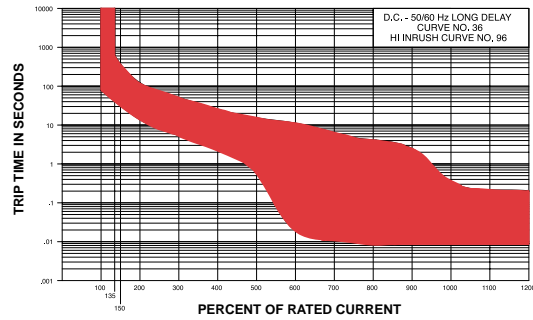

F-SERIES TIME DELAY VALUES									
TRIP TIME SECONDS	Delay	PERCENT OF RATED CURRENT							
		100%	125%	150%	200%	400%	600%	800%	1000%
11	No Trip	.013 - .125	.010 - .070	.008 - .032	.006 - .020	.005 - .020	.004 - .020	.004 - .020	.004 - .020
12	No Trip	.475 - 10.0	.275 - 2.80	.140 - .850	.030 - .190	.015 - .125	.010 - .050	.008 - .038	.008 - .038
14	No Trip	10.0 - 110	6.00 - 40.0	2.50 - 15.0	.500 - 3.00	.180 - 1.00	.010 - .280	.008 - .080	.008 - .080
16	No Trip	110 - 1000	60.0 - 400	22.0 - 150	4.00 - 25.0	1.00 - 5.50	.010 - 1.80	.008 - .390	.008 - .390
22	No Trip	.700 - 12.0	.350 - 4.00	.130 - 1.30	.027 - .220	.008 - .130	.004 - .090	.004 - .045	.004 - .045
24	No Trip	10.0 - 160	6.00 - 60.0	.220 - 20.0	.300 - 3.00	.050 - 1.30	.007 - .500	.005 - .060	.005 - .060
26	No Trip	50.0 - 700	32.0 - 350	10.0 - 90.0	1.50 - 15.0	.500 - 7.00	.020 - 3.00	.006 - 2.00	.006 - 2.00

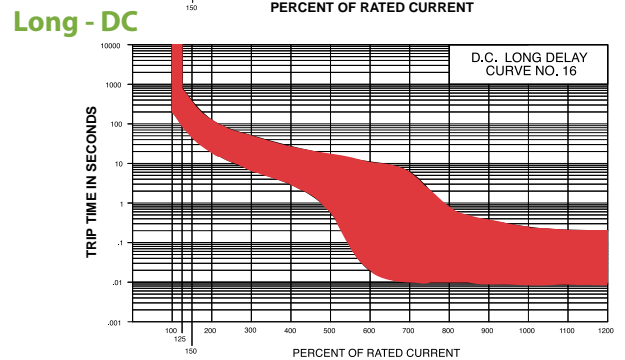
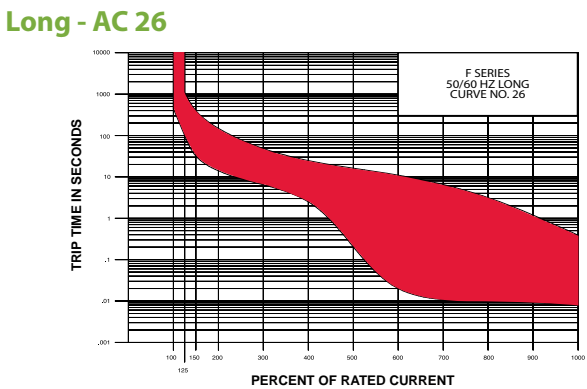
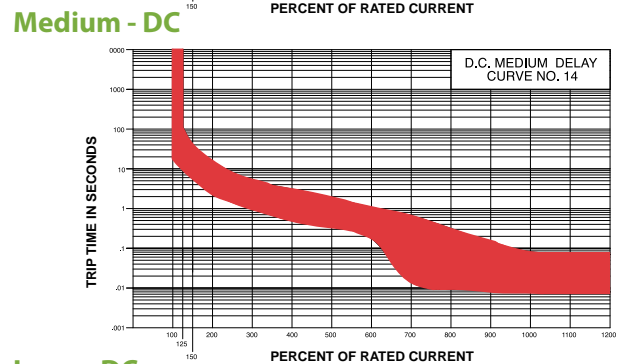
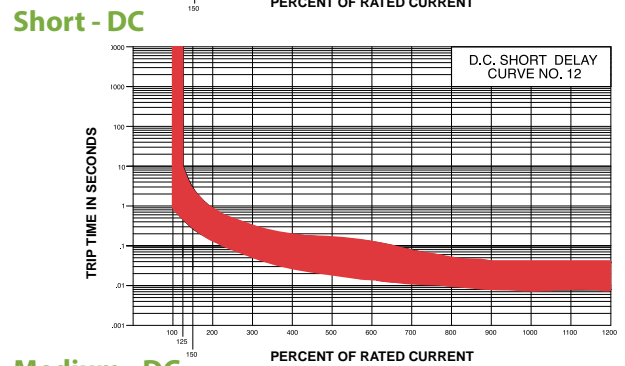
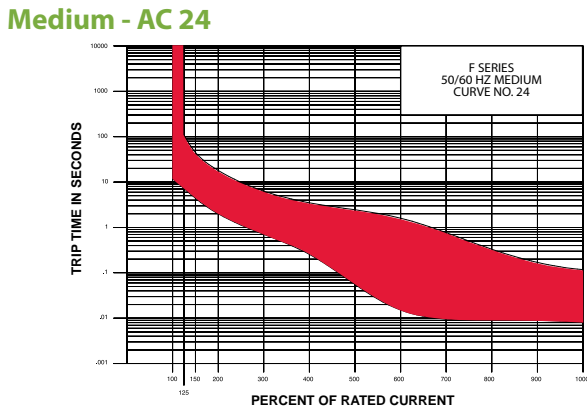
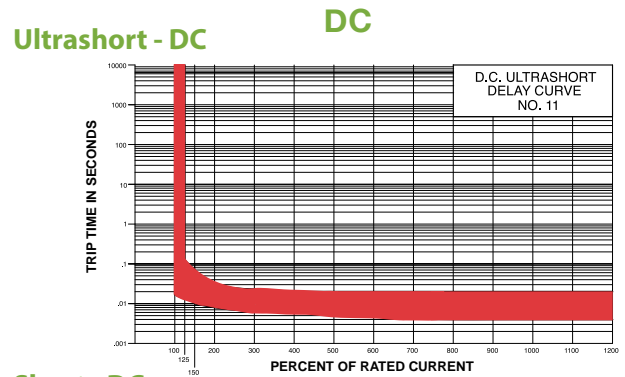
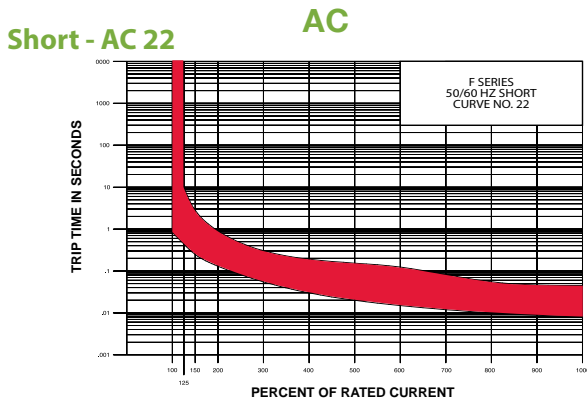

There are several catalogs available featuring complete details on all Carling Technologies products. Below is a list of useful information such as catalogs, brochures and videos. Please visit our website at carlingtech.com or scan the QR codes below for complete details.

www.carlingtech.com



Watch Company Profile Video



Switches & Controls

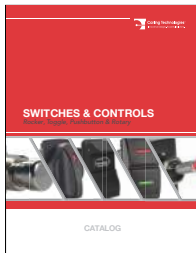

catalog

Complete line and ordering details for Switches & Control products including Rocker, Toggle, Pushbutton, and Rotary style switches.

Hydraulic-Magnetic

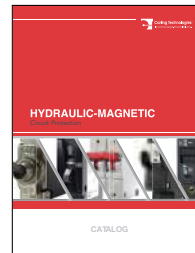

catalog

Complete line and ordering details for all hydraulic-magnetic circuit breakers.

Thermal

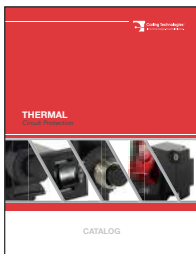

catalog

Complete line and ordering details for all thermal circuit breakers.

GFCI / ELCI

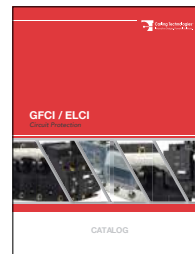

catalog

Complete line and ordering details for all GFCIs/ELCIs.

Marine



catalog



brochure

Complete line of ELCIs, thermal and hydraulic-magnetic circuit breakers specific for marine applications.

On-Off Highway



catalog



brochure

Complete line of switches, controls and custom solutions specific for on-off highway applications.

Renewable Energy

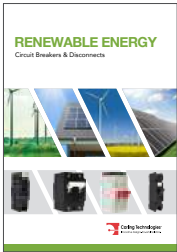

catalog



brochure

Complete line of circuit breakers and disconnect products specific for renewable energy applications.

Military

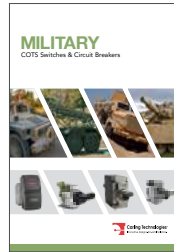

catalog



brochure

Complete line of COTS (*Commercial-Off-The-Shelf*) switches and circuit breakers specific for military applications.

Telecom/Datacom



catalog



brochure

Complete line of hydraulic-magnetic circuit breakers specific for telecom/datacom applications.

Industrial Automation



brochure

Complete line of switches and circuit breakers specific for industrial automation & controls applications.

Authorized Sales Representatives and Distributors

Click on a region of the map below to find your local representatives and distributors or visit www.carlingtech.com/findarep.



About Carling

Founded in 1920, Carling Technologies is a leading manufacturer of electrical and electronic switches and assemblies, circuit breakers, electronic controls, power distribution units, and multiplexed power distribution systems. With four ISO registered manufacturing facilities and technical sales offices worldwide, Carling Technologies Sales, Service and Engineering teams do much more than manufacture electrical components, they engineer powerful solutions! To learn more about Carling please visit www.carlingtech.com/company-profile.

To view all of Carling’s environmental, quality, health & safety certifications please visit www.carlingtech.com/environmental-certifications

Worldwide Headquarters

Carling Technologies, Inc.

60 Johnson Avenue, Plainville, CT 06062

Tel: (860) 793-9281

Fax: (860) 793-9231

Email: sales@carlingtech.com

Web: www.carlingtech.com

Northern Region Sales Office

nrsm@carlingtech.com

Southeast Region Sales Office

sersm@carlingtech.com

Midwest Region Sales Office

mrsms@carlingtech.com

West Region Sales Office

wrsms@carlingtech.com

Latin America Sales Office

larsms@carlingtech.com

Asia-Pacific Headquarters

Carling Technologies, Asia-Pacific Ltd.

Kowloon, Hong Kong

Tel: Int + 852-2737-2277

Fax: Int + 852-2736-9332

Email: sales@carlingtech.com.hk

Shenzhen, China

shenzhen@carlingtech.com

Shanghai, China

shanghai@carlingtech.com

Pune, India

india@carlingtech.com

Kaohsiung, Taiwan

taiwan@carlingtech.com

Yokohama, Japan

japan@carlingtech.com

Europe/Middle East/ Africa Headquarters

Carling Technologies Ltd.

4 Airport Business Park, Exeter

Airport, Clyst Honiton, Exeter,

Devon, EX5 2UL, UK

Tel: Int + 44 1392-364422

Fax: Int + 44 1392-364477

Email: ltd.sales@carlingtech.com

Germany

gmbh@carlingtech.com

France

sas@carlingtech.com

