

# INVOLUTE TOOLING CORPORATION

Manufacturers of Drives and Transmissions

## Reduction Gear Unit

The **Involute reduction gear unit** is a worm type unit with a modular construction. The unit comprises of hardened ground worms with centrifugally cast bronze gears.

If combined with an additional helical gear unit a heli-worm unit can also be supplied to give particular low output speeds. The helical gears are hardened and ground to close tolerances.

The gear unit can be supplied in the following combinations:

- 1) One or two output shafts.
- 2) Foot or flange mounted.
- 3) Hollow input for standard IEC motors.
- 4) Hollow output for direct shaft mounting.

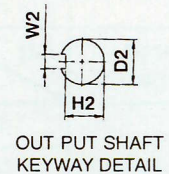
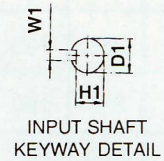
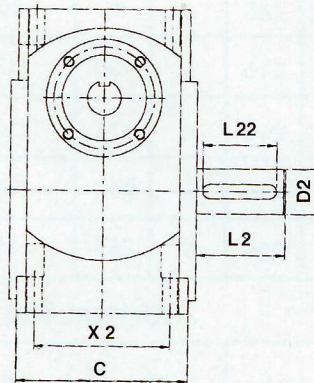
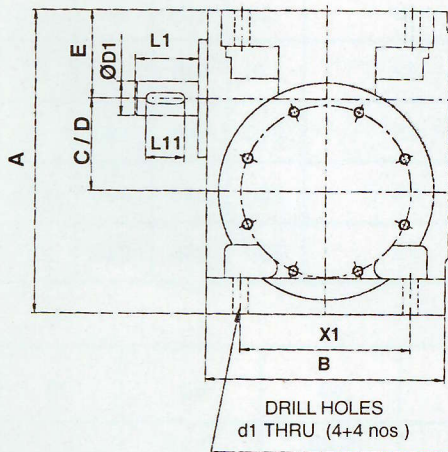
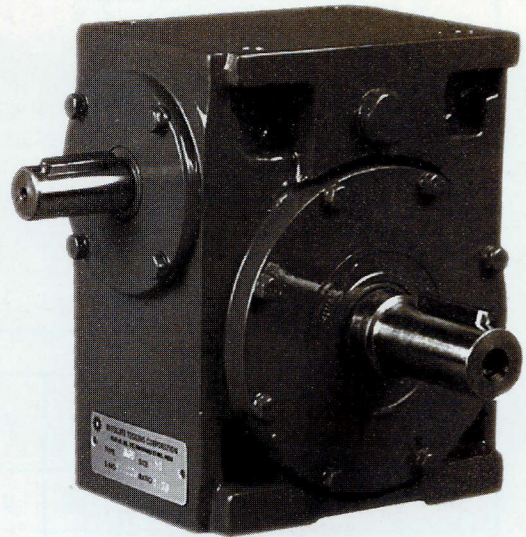

SIZE C/D	A	B	C	E	INPUT SHAFT					OUTPUT SHAFT					MOUNTING HOLES (THRU)		
					D1	L1	W1	H1	L11	D2	L2	W2	H2	L22	X1	X2	d1
40	150	110	90	49	19	40	6	15.7	32	19	50	6	15.7	35	75	65	8.5
51	168	133	96	49	19	40	6	15.7	32	25	51	8	21.7	35	95	76	8.5
63	205	160	120	62	25	50	8	21.7	35	28	80	8	24.7	60	110	90	10.5
85	262	195	140	70	28	60	8	24.7	45	42	85	12	36.5	75	140	110	13.0
101	325	250	200	108	32	65	10	27	50	45	90	14	39.5	80	180	160	18
130	405	300	250	125	36	70	10	31	55	48	105	14	42.5	90	240	190	19
152	450	354	300	127	38	75	10	33	60	60	114	18	53	100	266	240	23

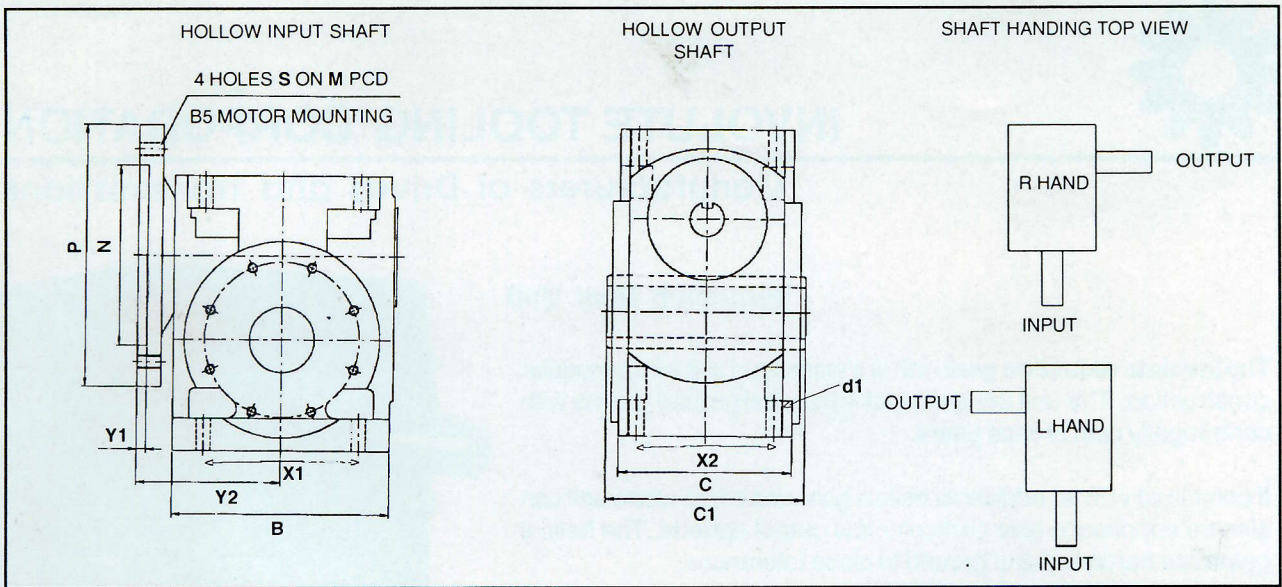

SIZE	P	N	S	M	Y1	Y2	B5 MOTOR FRAME SIZE	HOLLOW OUPUT SHAFT MAX mm	C1	X1	X2	d1
40	140	95	M 8 x 1.25	115	4	63	63	20	100	75	65	8.5
51	160	110	M 8 x 1.25	130	5	74	71	28	110	95	76	8.5
63	200	130	M 10 x 1.5	165	5	85	90 S	40	135	110	90	10.5
85	250	180	M 10 x 1.5	215	5	130	112 M	42	176	140	110	13
101	250	180	15	215	5	175	112 M	55	210	180	160	18
130	250	180	15	215	5	215	112 M	55	230	240	190	19
152	300	230	15	265	5	235	132	75	330	266	240	23

**NOMINAL RATIO / KW**

Input rpm	CD / KW	10	20	30	40	50	60	70
	1500	40	0.60	0.34	0.28	0.24	0.20	0.18
51		0.88	0.55	0.43	0.33	0.30	0.26	
63		1.45	0.88	0.70	0.55	0.50	0.44	0.42
85		3.70	2.00	1.75	1.40	1.24	1.10	0.90
101		4.40	2.55	2.00	1.50	1.45	1.18	1.15
130		12.60	6.40	5.50	4.20	3.00	2.60	2.10
152		16.80	10.10	7.30	6.20	4.70	4.50	3.60
1000	40	0.48	0.30	0.25	0.20	0.18	0.16	
	51	0.65	0.42	0.35	0.27	0.25	0.22	0.19
	63	1.15	0.72	0.62	0.45	0.44	0.35	0.33
	85	2.75	1.80	1.60	1.19	1.00	0.85	0.80
	101	3.30	2.26	1.80	1.32	1.18	0.96	0.90
	130	9.20	4.70	4.20	3.00	2.20	1.90	1.60
	152	14.00	7.80	5.60	4.60	3.90	3.30	2.80