

500-1100  
e-FOB System

# TriMark®



**DESIGNED FOR:**

- TriMark's e-ASK systems consist of a selection of compatible components that allow for complete keyless entry for on or off-highway vehicle applications
- Incorporation into TriMark mechanical latches, handles and systems by providing keyless entry, security and convenience for access door systems through a RF remote fob electronics interface



**TriMark Corporation**  
500 Bailey Avenue  
P.O. Box 350  
New Hampton, Iowa 50659  
United States  
Tel: 641-394-3188  
Fax: 641-394-2392  
1-800-447-0343  
www.trimarkcorp.com

10002707 QM08  
10002707 TS09  
 ISO 9001: 2008  
ISO/TS 16949: 2009  
TriMark Corporation

**TriMark Europe**  
Cedar Court  
Walker Road  
Bardon Hill  
Coalville LE67 1TU  
United Kingdom  
Tel: +44(0)1530 512460  
Fax: +44(0)1530 512461  
www.trimarkeu.com

427961 QM08  
427961 UM  
 ISO 9001 : 2008  
ISO 14001 : 2004  
TriMark Europe Ltd.

**FEATURES/BENEFITS:**

- Increased end user convenience
- Easy and intuitive to operate
- Rugged and durable construction
- Compliant to on-road, off-road, and industrial environmental requirements
- Increased vehicle security with multiple triggers and outputs
- Includes on-board locking and unlocking relays for up to 4 actuators
- Numerous entry/compartament doors
- Locking/unlocking confirmation
- Ignition controlled auto-locking
- Starter deactivation available for increased security
- Lighting and auxiliary output control
- Panic mode outputs
- Valet mode
- Reliable radio frequency (RF) transmission
- FCC-Part 15 compliant
- Complete kit with wire harnesses and other accessories
- High security with code hopping technology

**INSTALLATION:**

- Standard 12 VDC power
- e-FOB receiver is easily installed with (2) #6 or M3 screws (not included) and can be mounted in a concealed location

**AVAILABLE:**

- Standard kit make up includes: 2 pre-trained RF remote fob transmitters, RF receiver, 14 wire harness, 10 wire harness, 2 wire harness, push button switch, and LED assembly key rings and manual
- Optional kits can include: extra relays, switches, door contacts, actuators, mounting hardware, mounting brackets, door latches, and door paddle handles
- Customized wire harnesses
- High security with code hopping technology
- 4-button standard fob
- Customized graphics possible (buttons and logos - please inquire)
- Can add up to 4 fob transmitters to vehicle

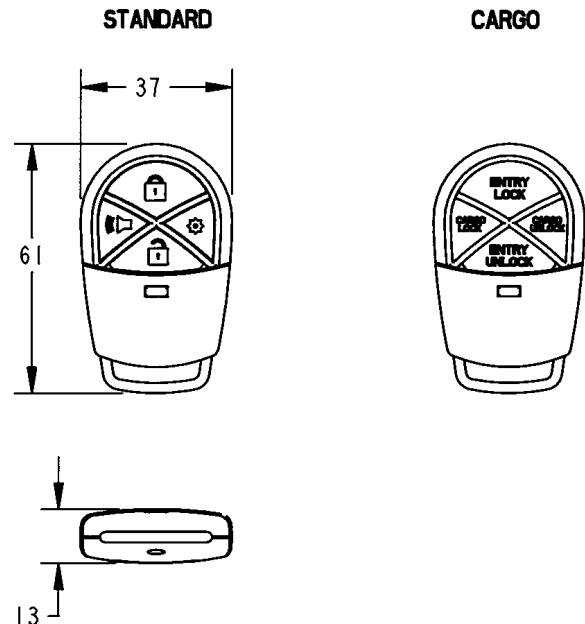

- 3 different programming functions; standard mode, cargo mode and sustained mode. Modes provide customized remote fob transmitter use. Standard mode allows for the lock/unlocking of doors plus panic mode and one auxiliary output (controls lighting, opens compartment etc). Cargo mode allows for the lock/unlocking of main personnel doors plus independent control of many cargo/compartment doors. Sustained mode allows for the lock/unlocking of doors plus continuous output control with lower buttons pressing.

**USE WITH:**

**Mechanical**

- TriMark 030-0175 Stamped Steel Compartment Latch
- TriMark 030-0185 Stamped Steel 2-Point Paddle Handle
- TriMark 030-0400 Paddle Handle
- TriMark 030-0425 Inside Bezel & Release Lever Assembly
- TriMark 030-0450 2-Point Paddle Handle
- TriMark 030-0850 Flush Mounted Paddle Handle
- TriMark 030-0860 Flush Mounted Paddle Handle With Inside Lock Knob
- TriMark 030-0900 Motor Home Entrance Door Hardware With Dead Bolt
- TriMark 030-1100 2-Point Paddle Handle
- TriMark 030-2000 2-Point Free Float Baggage Lock
- TriMark 050-0250 Single Rotor Latch & Linkage Assembly

**Electronic Products and Accessories**

- TriMark 500-1200 e-PAD System
- TriMark 510-0100 e-ASK I/O Module
- TriMark 550-0100 Power Actuators
- TriMark 550-0200 Solenoids
- TriMark 590-0100 Wire Harnesses
- TriMark 590-0200 Door Contacts
- TriMark 590-0300 Relays
- TriMark 590-0400 Sirens
- TriMark 590-0500 Rocker Switches
- TriMark 590-0600 Plunger Switches
- TriMark supplied or existing OEM security system components (e.g. motion detectors, door-ajar detectors, glass break sensors)

Design Patent No. D563,097 / D590,780 / D589,000

**Please refer to individual product codes and part drawings for complete dimensions, specifications, and installation procedures. Engineering assistance and application drawings are available.**

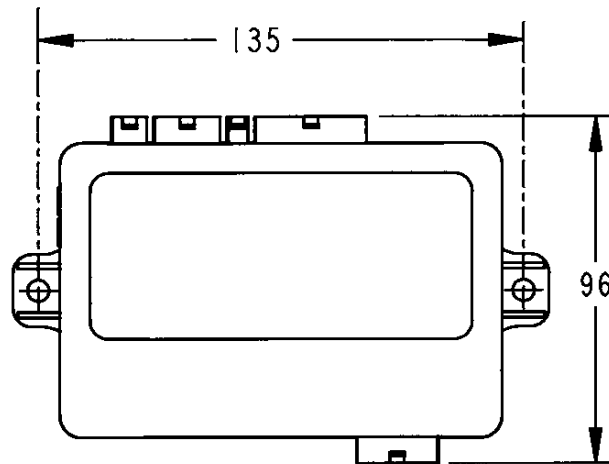

For more information visit:  
[www.trimarkcorp.com](http://www.trimarkcorp.com)

