

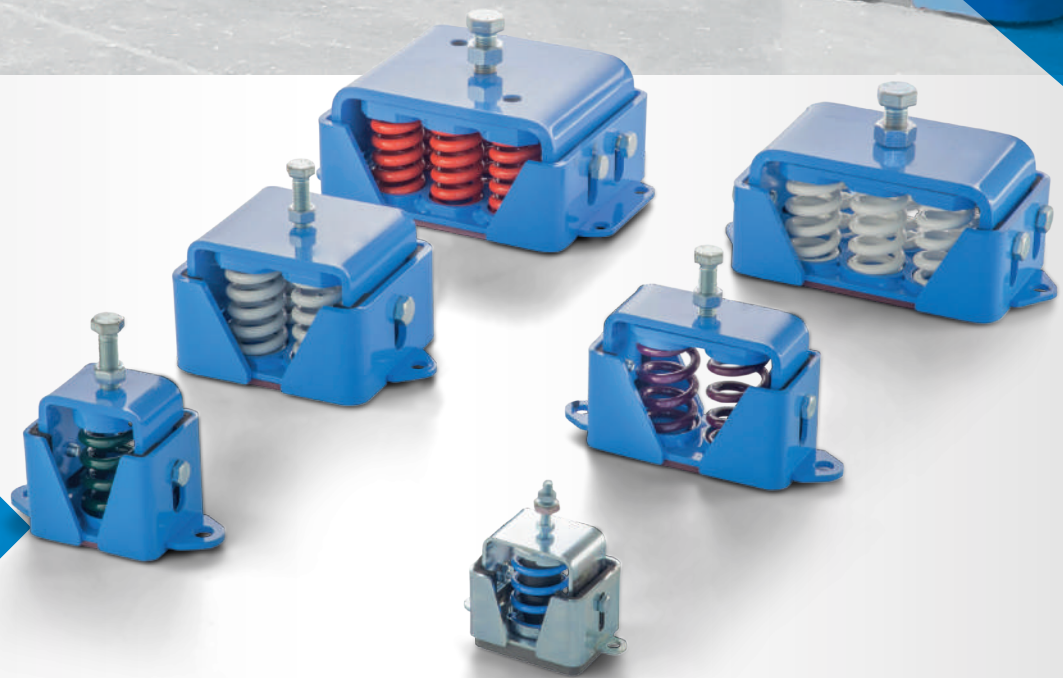

Vibrabsorber + **sylomer**[®] General Catalogue

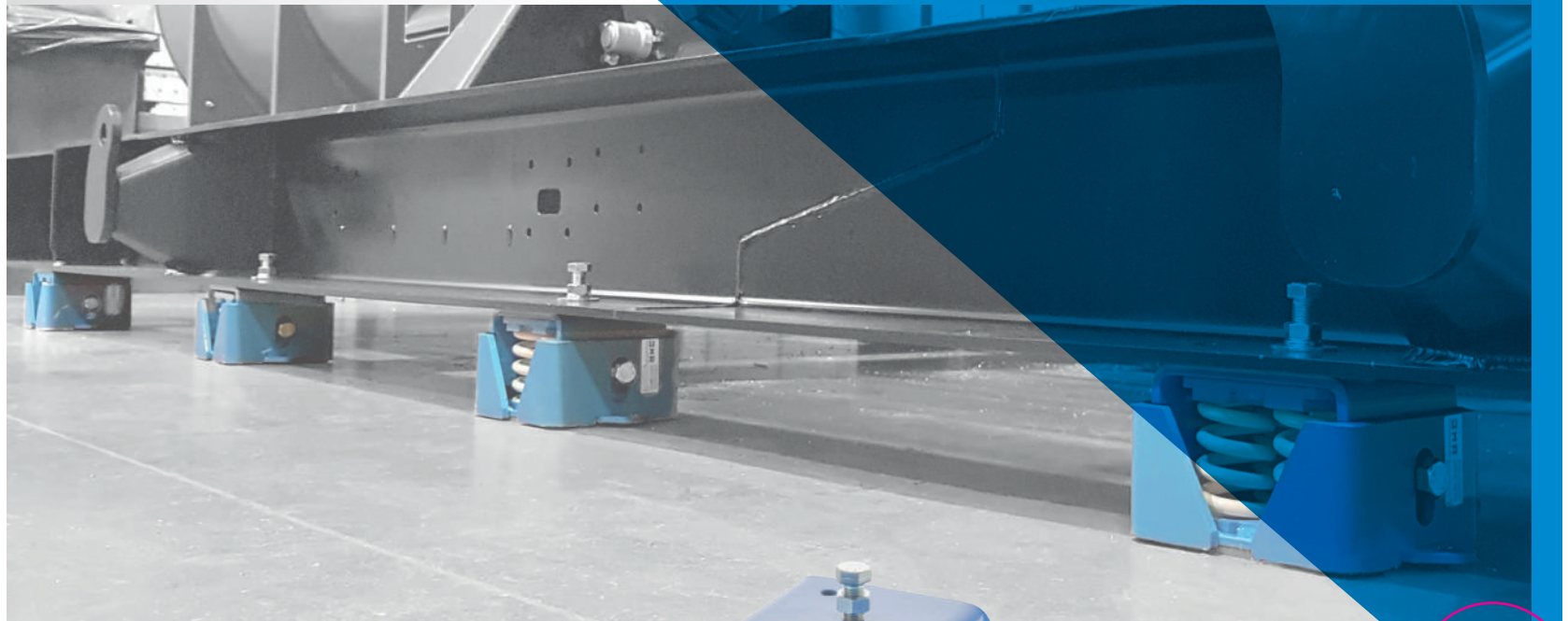

AMC
MECANOCAUCHO

50 YEARS OF EXPERIENCE ENDORSE US

Since 1969 **AMC MECANOCAUCHO[®]**, has pioneered the manufacture and design of products for the attenuation of vibrations and noise.

Factory 1 in Asteasu.



Factory 2 in Asteasu.



1969



1995



INDEX

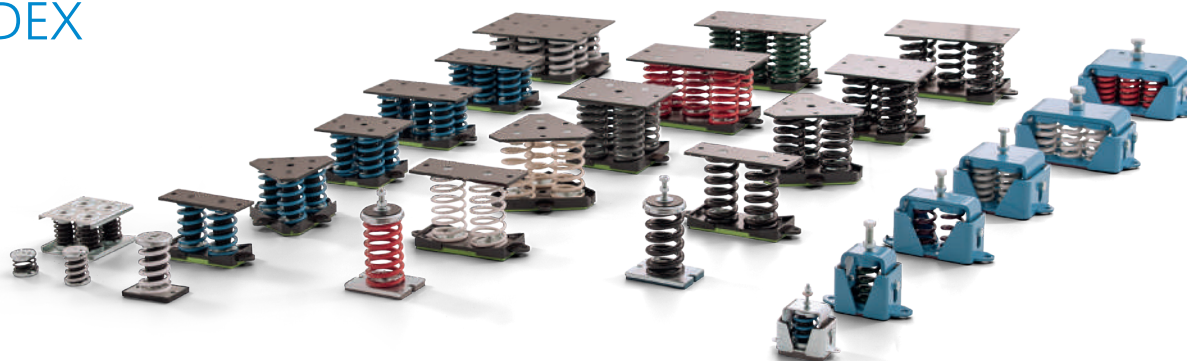

Areas of application	page 4
Quality commitment	page 6
The solution	page 7
AMC Engineering	page 8
Theory of vibration isolation	page 12
Vibrabsorber mount Characteristics	page 15
Advantages of the vibrabsorber + sylomer® mounts	page 16
B SERIES	page 20
MEDIUM SERIES	page 21
BASES & 1 AMC Dual Cap	page 22
4 AMC T	page 23
1 AMC	page 24
2 AMC	page 25
3 AMC	page 26
4 AMC	page 27
5 AMC	page 28
6 AMC	page 29
9 AMC	page 30
Ps + Sylomer®	page 31
VT	page 32
VT HD	page 33
V-SH	page 34
V-SR	page 38
Anti-seismic + sylomer® mounts	page 42
VSH anti-seismic supports	page 46
VSR anti-seismic supports	page 48
Anti Seismic Visco	page 50
Other AMC products	page 52



AREAS OF APPLICATION

Our products are used in sectors such as:

- Generation of electrical energy.
- Air compressors and Blowers.
- Pumps and Pumping equipment.
- Industrial vehicles.
- Machine Tools.
- Marine propulsion and auxiliary equipment.
- Agricultural and construction equipment machinery.
- Acoustic isolation of premises.



Compressor insulated with VIBRABSORBER +Sylomer®



Generator set insulated with VIBRABSORBER+Sylomer®

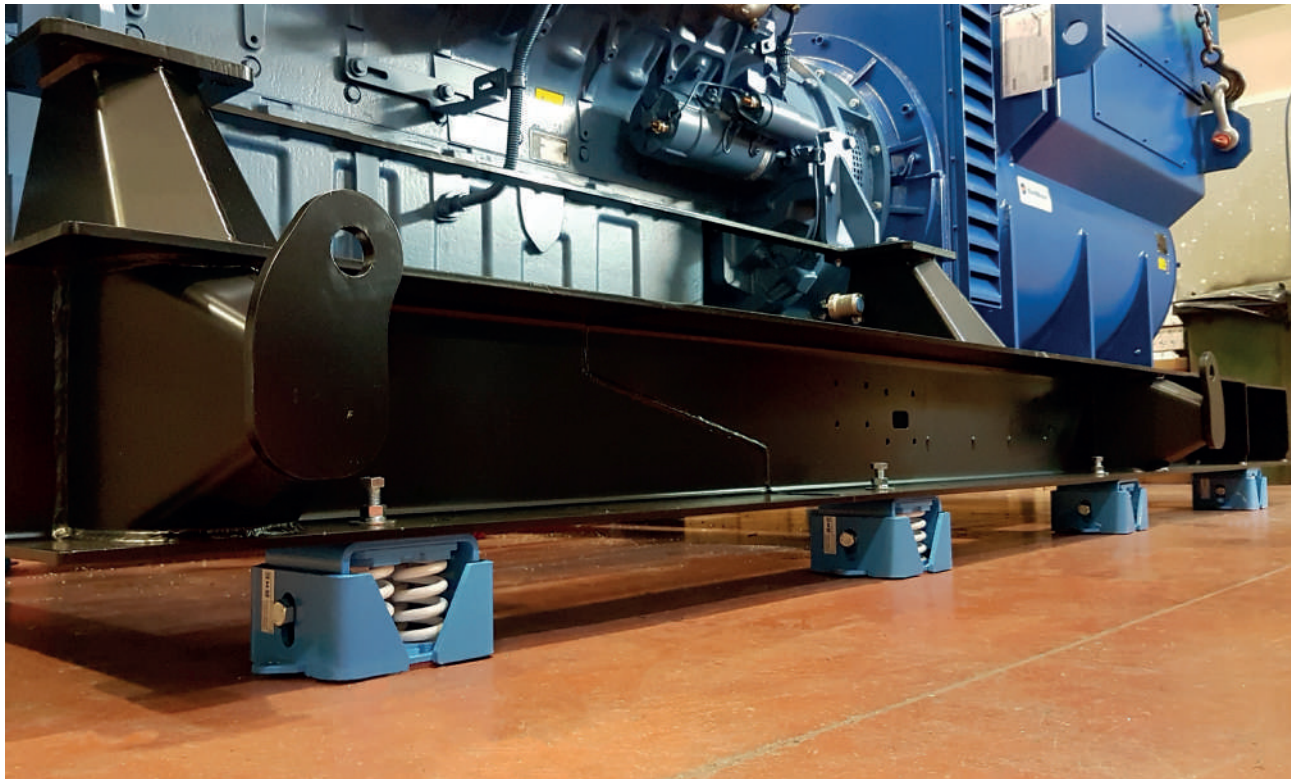

Generator set insulated with VIBRABSORBER+Sylomer®

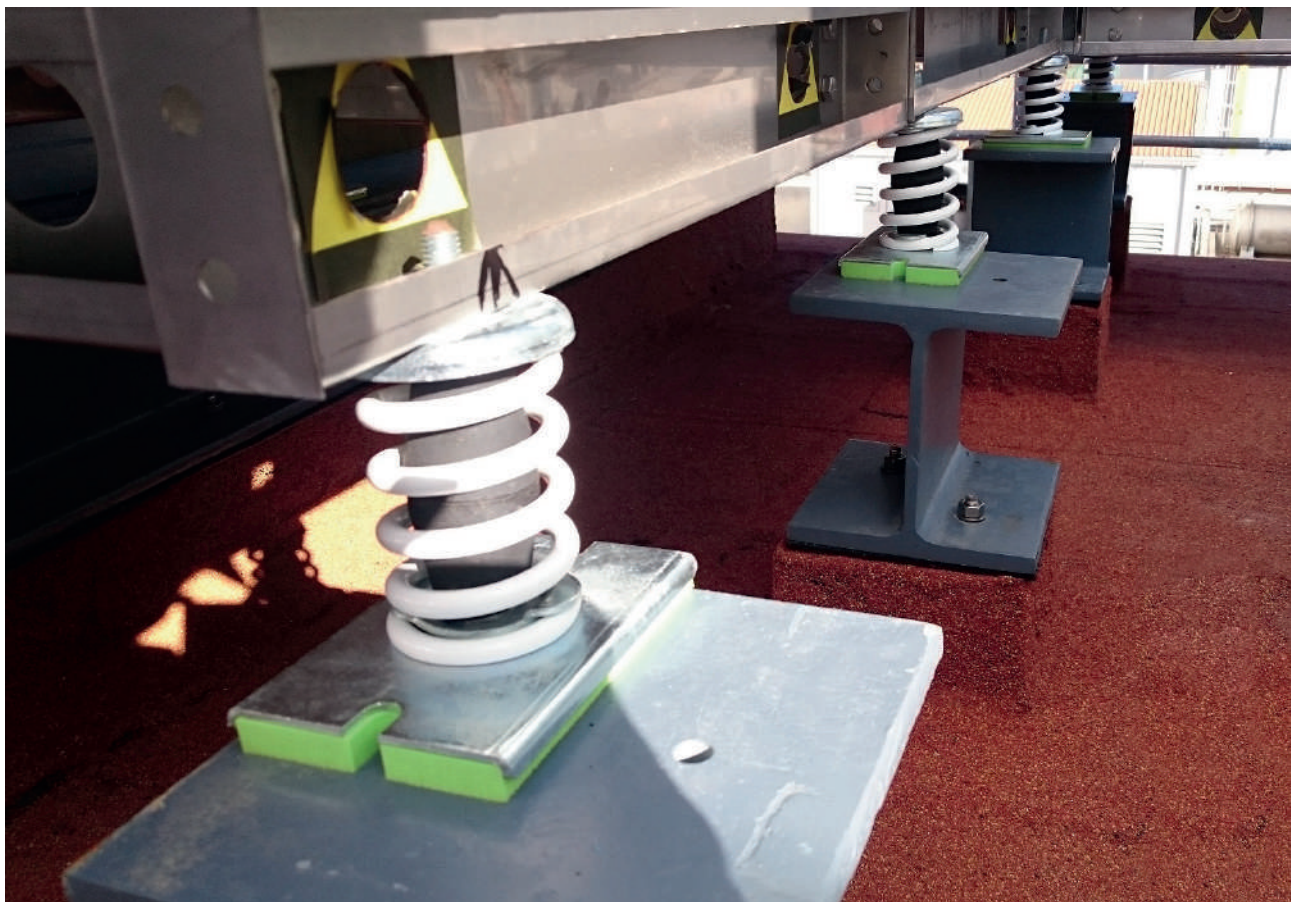

Ventilation system insulated with VIBRABSORBER



QUALITY COMMITMENT

The products commercialised by AMC-MECANOCAUCHO® are all made in-house.

The stiffness and levels of mechanical fixations of all these products have been controlled so that they may be identified as “AMC MECANOCAUCHO®” products, whereby they can be traced. AMC MECANOCAUCHO® is officially approved by the NATO under the ID no. NCAGE 0230 B-compliant supplier.

ISO 9001:2014



ISO 14001: 2014



Marine type approval



NATO certificate

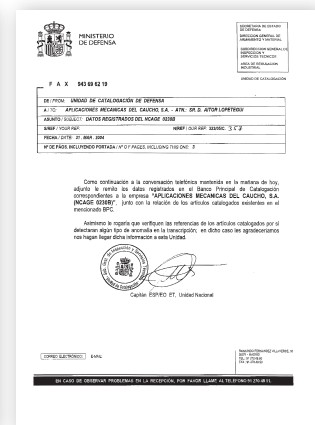

THE SOLUTION

All machinery which by virtue of its design, has reciprocating or rotating parts, creates vibration to some degree through the imbalance of the moving parts.

This vibration produced by a machine leads to different problems, such as a reduction in the machine's useful life through part wear, plus the transmission of this vibration to other non-insulated adjacent structures, giving rise to problems of noise and vibration transmission.

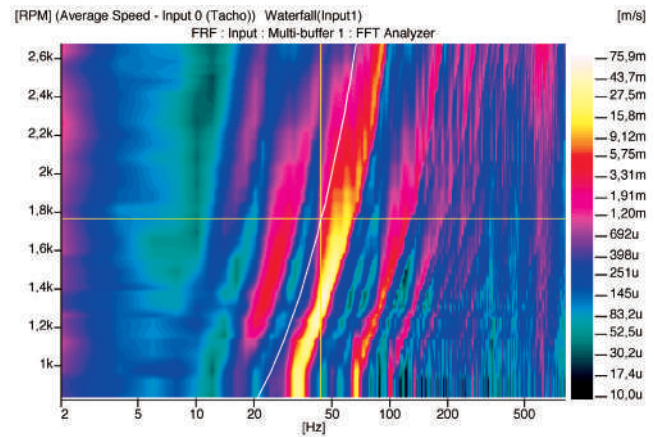

FFT analysis of orders for a diesel engine

For over 45 years, AMC MECANOCAUCHO® has been developing the AMC MECANOCAUCHO® range of rubber-metal anti-vibration supports which can solve problems like the ones described above in all types of machinery, mobile or fixed. Thus protecting people and the environment from harmful effects of noise and vibration.

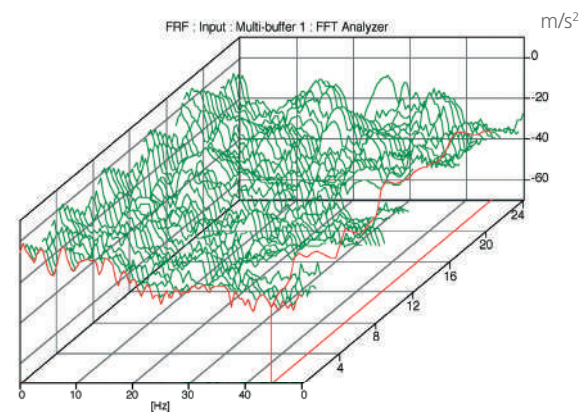
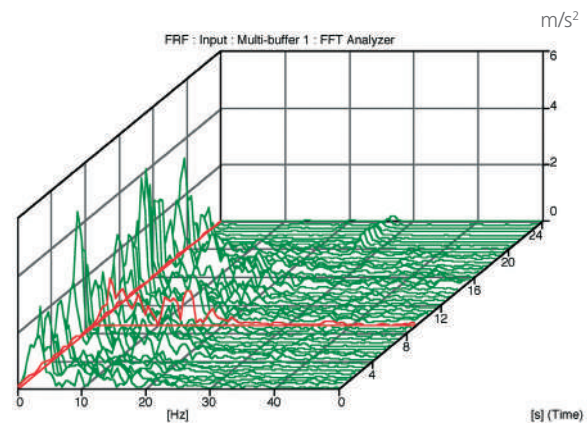

3D graphics of the vertical acceleration of a radiator

1. Calculation

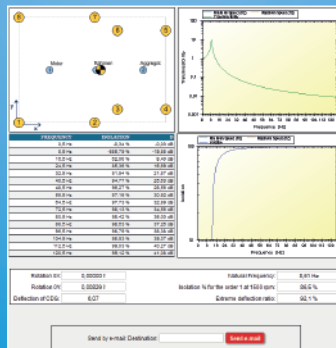
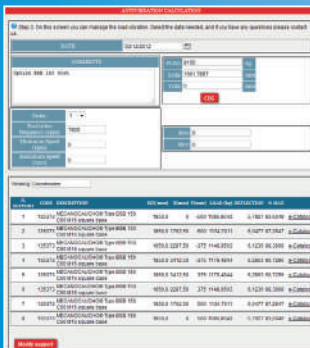
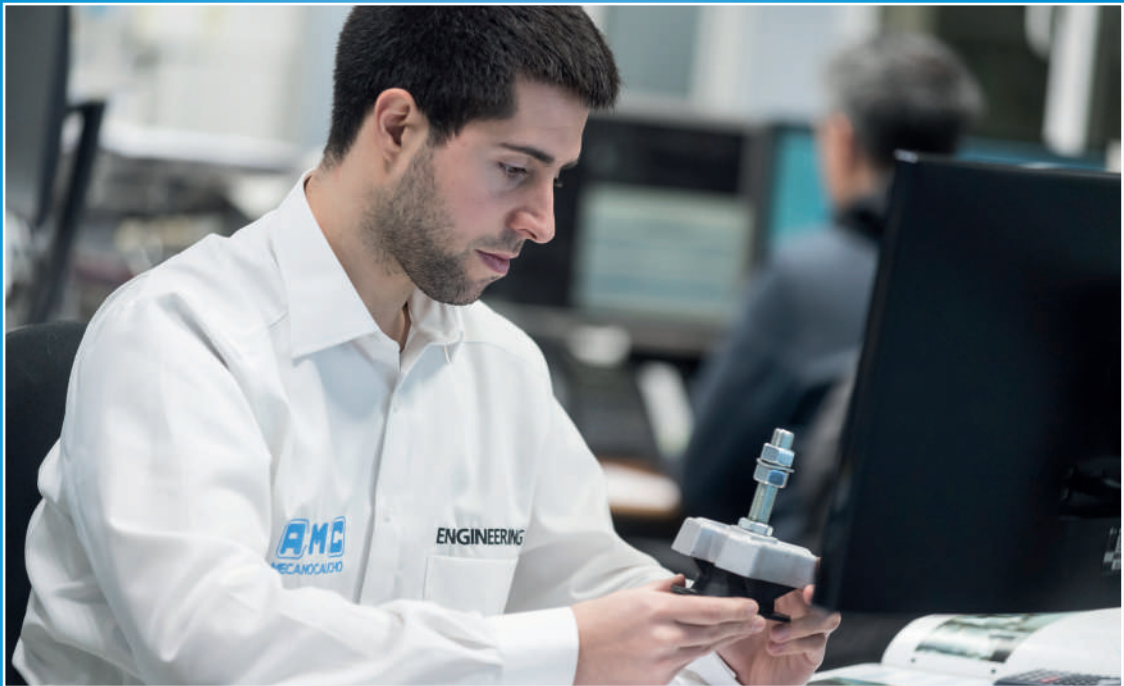

AMC MECANOCAUCHO® calculates anti-vibration solutions by taking into account data such as weight, mount positions, type of machine, C. of G., frequency of excitation, etc...

One degree of freedom calculation

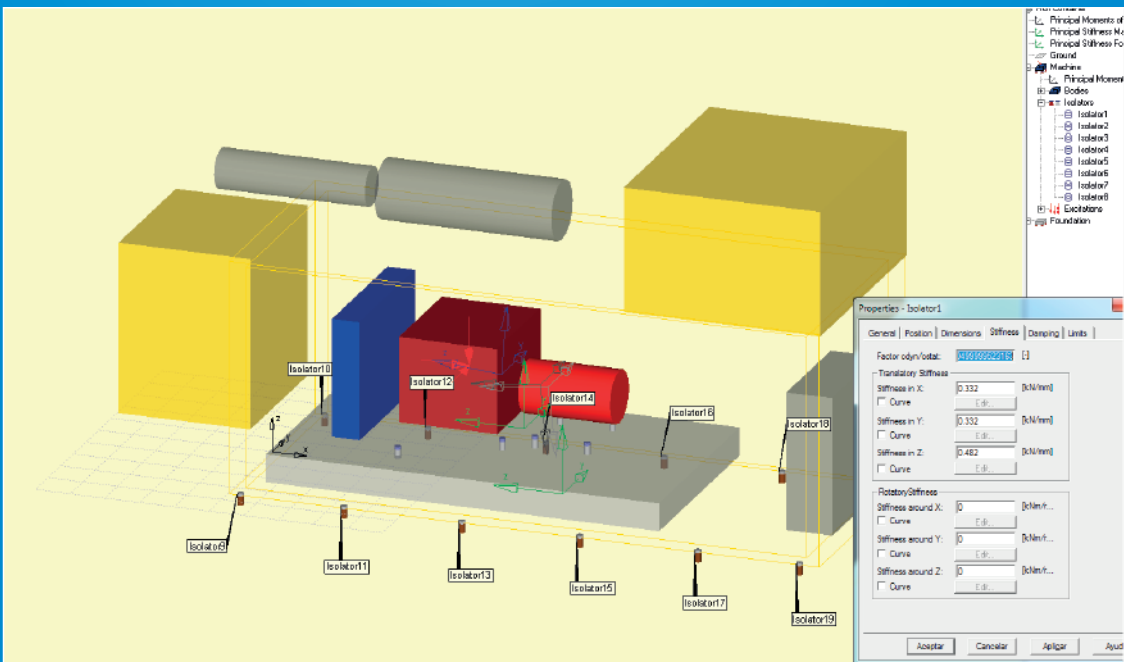

Anti-vibration calculation with more than one degree of freedom.

2. Design



After studying each client's specific needs for the application and the isolation performance required, **AMC MECANOCALCHO®** can design new products where conditions permit.

Tension tests by non linear FEM.

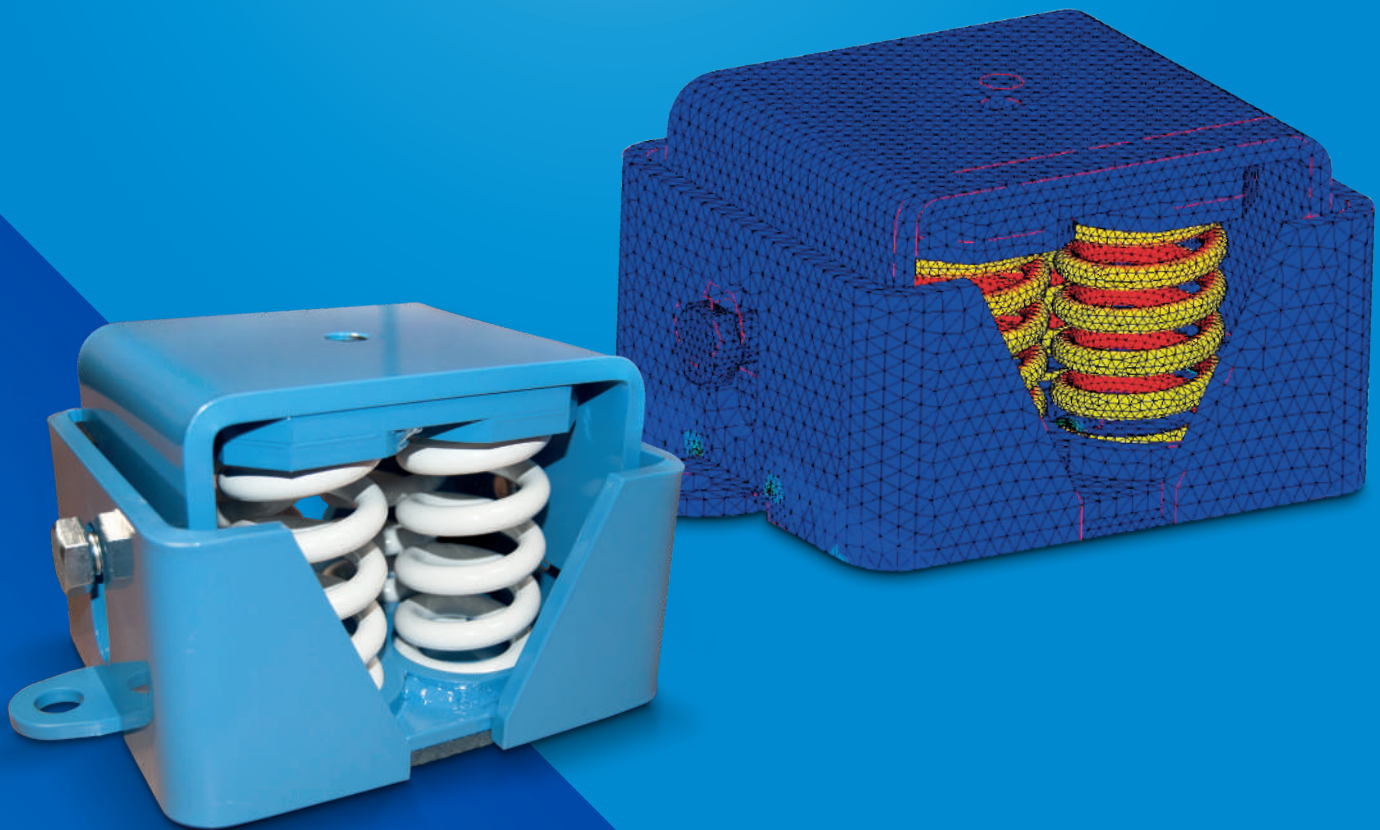

3D modelling of products

3. Test and dynamic characterisation

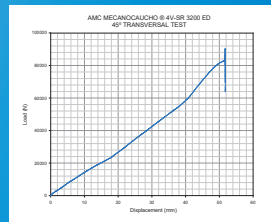
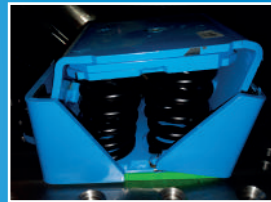
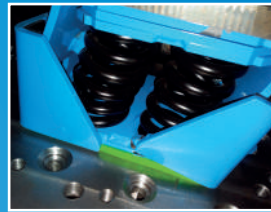

AMC MECANOCAUCHO® continuous development of new products demonstrates its support in R&D. Our laboratory is equipped with the most advanced dynamic testing equipment.

4. Vibration Measurement

Vibration Measurement

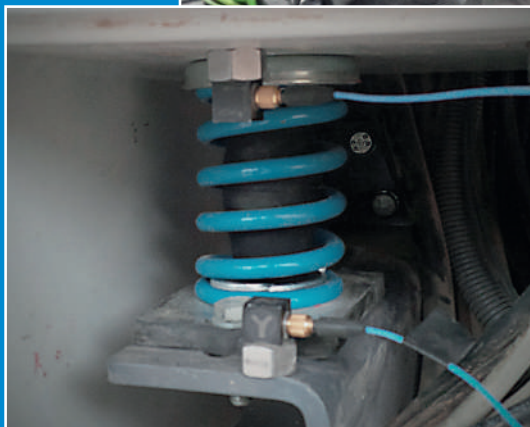

AMC MECANOCAUCHO® provides its clients with many years of experience and know how in measuring vibrations and noise in the field so as to reduce machine-produced emissions of noise and vibrations.



AMC
ENGINEERING

THEORY OF VIBRATION ISOLATION

1.- ABC AT A GLANCE

MASS SPRING SYSTEM

A mass spring system may be represented by a mass "M", excited by a force "F" and supported on an elastic stiffness element "K" with a dampening factor "C".

The frequency of the mass spring system is equal to:

$$f_o = \frac{1}{2 \cdot \pi} \sqrt{\frac{k}{M}}$$

figure 3

K = N/m
M = in Kg
Fo in Hz
C in Ns/m

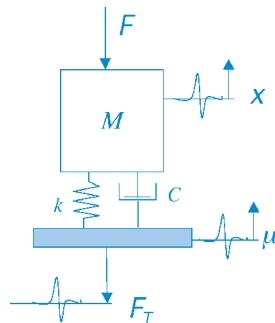

The effectiveness of the suspension may be measured by transmissibility, i.e. by the force which is transmitted by the machine to the ground or floor. It is defined as the ratio between the force transmitted to the ground, FOT, and the original force produced by the vibration FO.

Another practical term is often used to describe the efficacy of an anti-vibration mount, namely the degree of insulation, which is:

Transmissibility equation: $E = (1 - T) \times 100\%$

Taking the following parameters into account:

Excitation $x = x_o \sin(\omega t + \vartheta)$
 $F = F_{TO} \sin(\omega t + \vartheta)$

Response $\mu = \mu_o \sin \omega t$
 $F = F_o \sin \omega t$

Own Pulsation: $\omega_o = \sqrt{\frac{k}{M}}$ for $C \cong 0$

and natural frequency of $f_o = \frac{1}{2 \cdot \pi} \sqrt{\frac{k}{M}}$

The damping parameters are: $C_c = 2 \cdot \sqrt{kM}$

Where C_c is the critical damping and $\xi = \frac{C}{C_c}$ the damping coefficient.

For this system we obtain a transmissibility T and a magnification factor A:

$$T = \frac{x_o}{\mu_o} = \frac{F_{TO}}{F_o} = \sqrt{\frac{1 + \left(2 \cdot \xi \cdot \frac{\omega}{\omega_o}\right)^2}{\left(1 - \frac{\omega^2}{\omega_o^2}\right)^2 + \left(2 \cdot \xi \cdot \frac{\omega}{\omega_o}\right)^2}}$$

For the case of active $T = \frac{F_{TO}}{F_o}$ and

passive isolations, we will have to $T = \frac{x_o}{\mu_o}$

Figure 5 represents the transmissibility curve of the schematic mass spring system of figure 3.

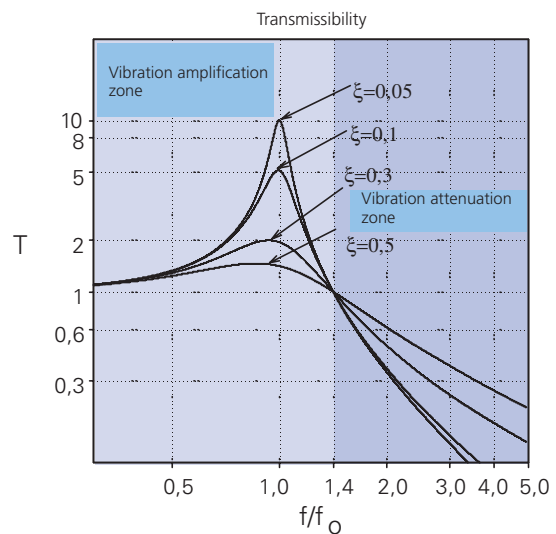

Examining this curve allows us to reach basic conclusions for an effective isolation.

If the frequency of excitation is $\sqrt{2}$ times less the natural frequency, transmissibility is greater than one, then the force transmitted is greater than the excitation force, there is magnification of the vibrations. When we work in this area, the existing damping in the system is important. The greater the latter, the smaller the magnification of the vibrations will be.

If the frequency of excitation is $\sqrt{2}$ times greater than the natural frequency, transmissibility is less than one, or in other words the force transmitted is less than the force originated in the system, then we are in the damping area.

In order to achieve the greatest isolation, the lowest possible natural frequencies should be sought. There are two ways of doing this:

- By increasing the system mass.
- By reducing the stiffness of the anti-vibration mount.

To increase the efficacy of the isolation in the damping area, it is advisable to have low damping, although weak damping generates greater displacement when passing through the resonance, it is advisable to use a damping coefficient t so that passage through the resonance does not give rise to inadmissible displacement for the machine.

STATIC AND DYNAMIC STIFFNESS

All elastomers suffer dynamic stiffening but metallic springs have a very low dynamic stiffening due to the low internal friction of the metals. Therefore we can consider that the springs have identical static and dynamic stiffness.

DAMPING

The metallic springs have very low damping. As we have mentioned previously, the metal spring coils, do not show any internal friction and therefore there is no energy dissipation through this phenomenon.

Dynamic laboratory tests have shown in practice that the damping for this kind of mounts is almost null and this is the reason why these mounts have been combined with viscous dampers for applications where more damping is demanded. For example genset suspensions.

CREEPING AND LONG-TERM BEHAVIOUR

The spring mounts do not have the creeping and continuous increase of deflection all elastomers have, but spring coils have also certain relaxation that depend on the applied load and the temperature. The higher the load and temperature are, the higher is the relaxation. Temperatures above 80°C and high loads, may cause a small loss of height in the spring. This set is always lower than the usual values of elastomers.

VIBRATION ISOLATION GRAPH

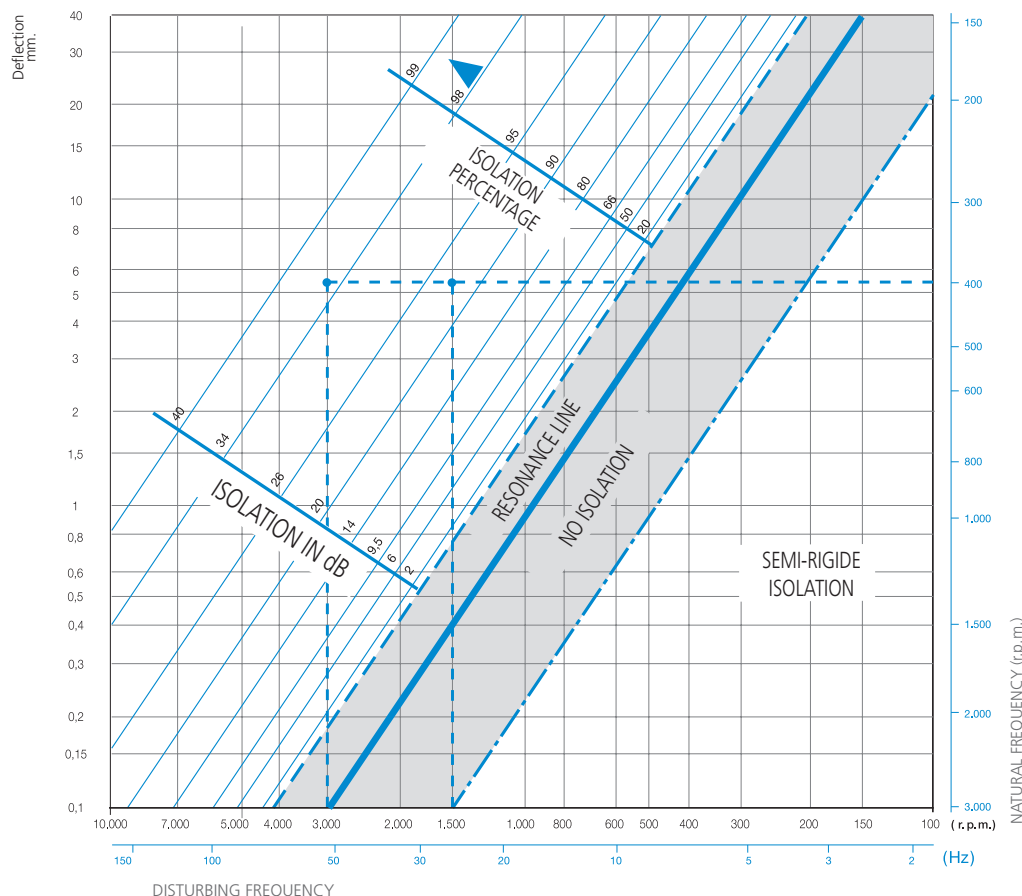

THEORY OF VIBRATION ISOLATION

1.- DYNAMIC TESTING MACHINE

Dynamic stiffness can only be established by measurement on a dynamic test bench. Similarly, the damping coefficients of compounds are further values that can be measured with this type of machines.

One concept that must be taken into account when designing an anti-vibration mount is its durability. A dynamic testing machine allows us to conduct fatigue tests that reproduce the real working conditions of the part so that its useful life can thus be predicted.

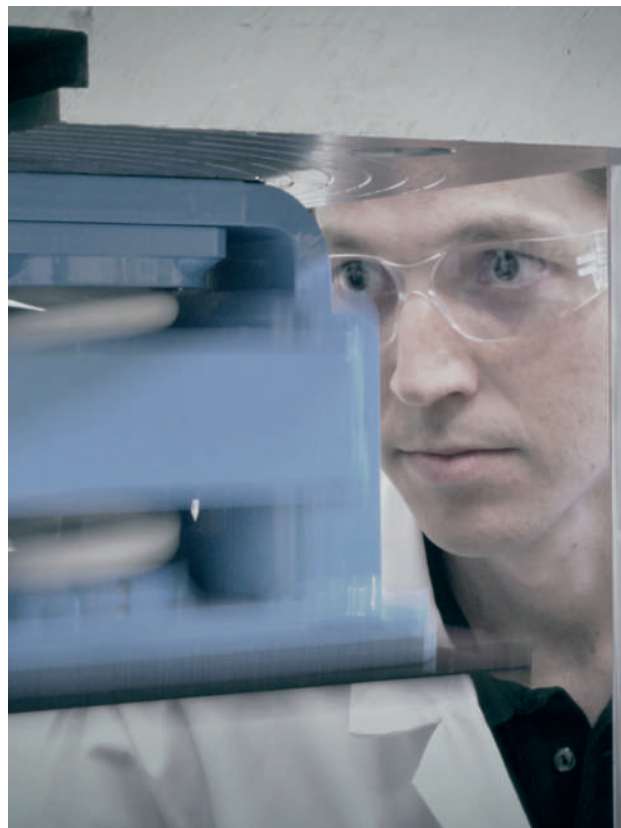

2.- ANALYSIS OF SYSTEMS OF MORE THAT ONE DEGREE OF FREEDOM

In actual fact, there are cases where the model of 1 degree of freedom cannot correctly define the behaviour of the equipment to be isolated. In such cases AMC MECANOCAUCHO® engineers have analysis tools that enable more elaborate models to be made taking into account the 6 Degrees of Freedom rules.

The latest computing tools can also generate virtual models of solid rigid multiples and study how they interact with each other and with the environment.

As a result, we can ascertain the natural frequencies of the system which are really important to prevent them from coinciding with the excitation frequencies so as not to have resonance problems.

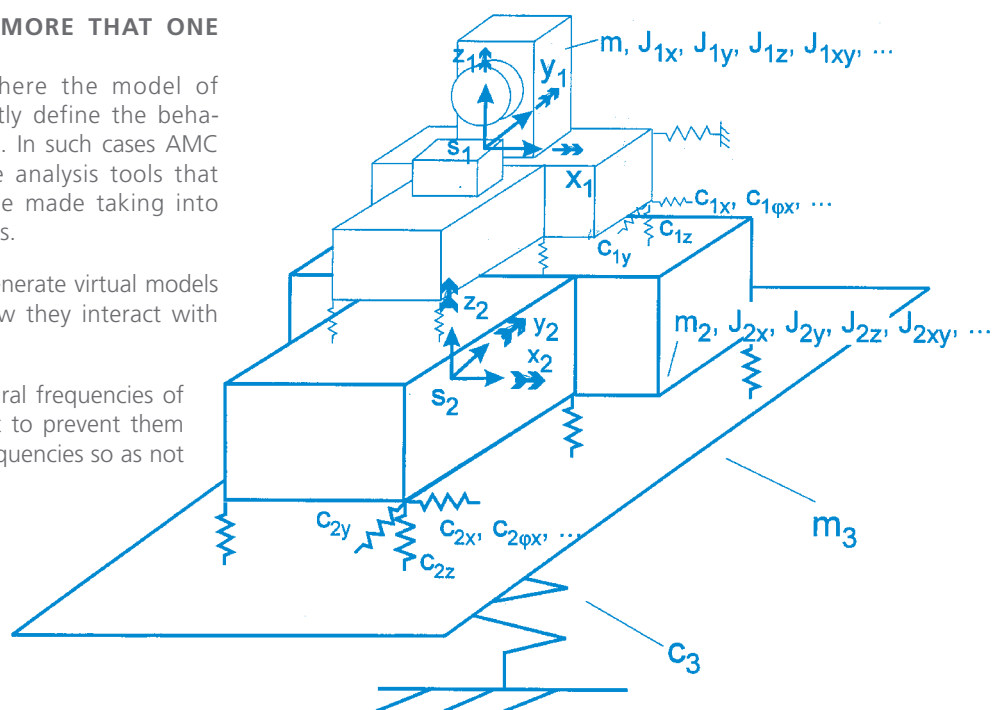

VIBRABSORBER MOUNT CHARACTERISTICS

FUNCTION OF INVERTED DOUBLE CONE INSIDE THE SPRING

The function of this element is to limit the compression of the spring in case of an unexpected overload, acting as an end-of-stroke buffer

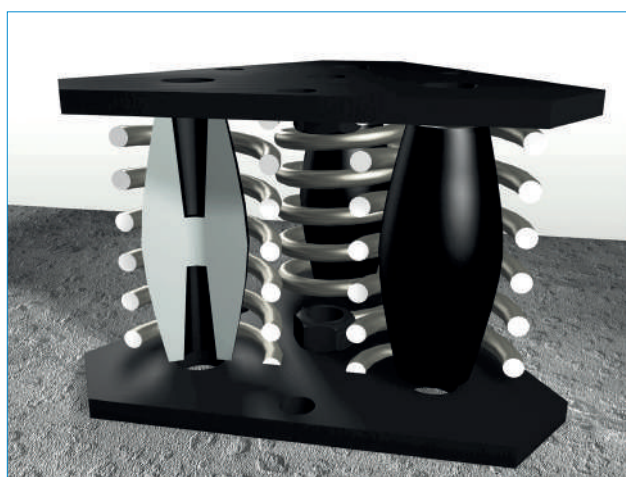

Typical behaviour in compression

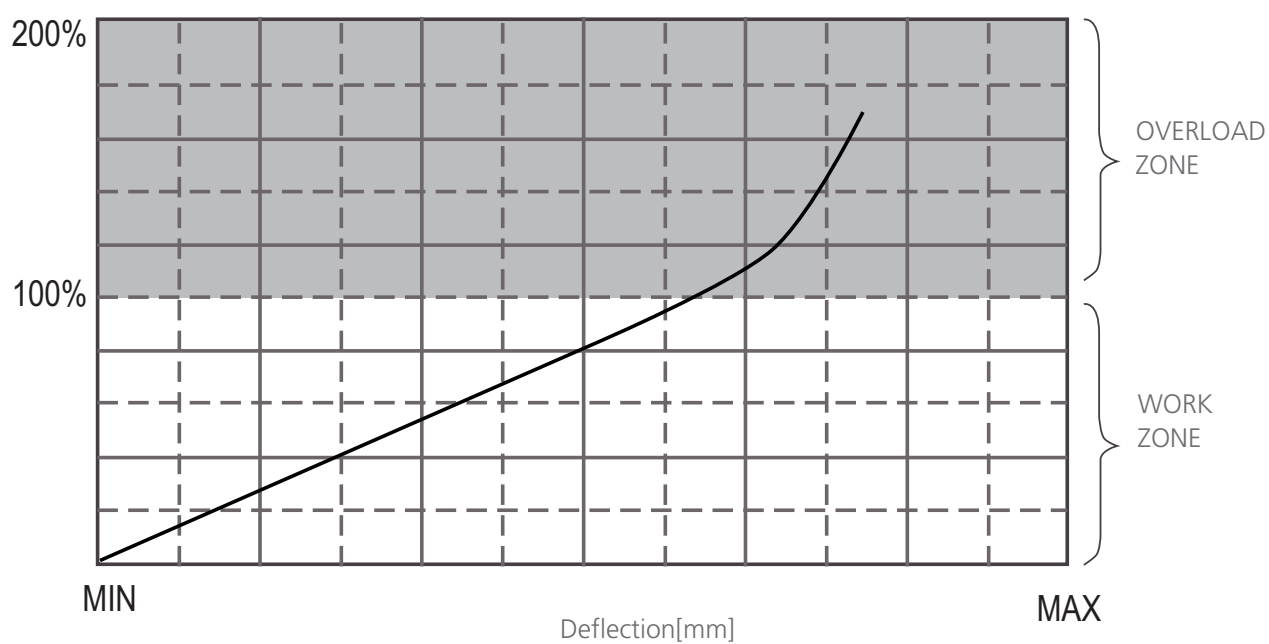

THE ADVANTAGES OF THE Vibrabsorber + sylomer[®] by getzner

- The SYLOMER[®] mat that these dampers incorporate, isolates the mid-high frequency vibrations which are transmitted through the coils of metal springs.
- These high and mid-range frequencies, if they are not isolated, are spread throughout the buildings or structures, generating noise.

With the aim to confirm the advantages of applying Sylomer[®] on our spring system, an analysis of FFT was carried out on fan system of a known international make.

OBJECTIVE OF THE TEST

The objective of this test is to compare the isolation which the Vibrabsorber springs offer with or without Sylomer[®].

MEASURES USED

- **Reference of the Machine:**
Refrigerator set Power 20Kw
- **Supports set:** 1 AMC 250 + Sylomer[®] P12
- **Measuring equipment:** FFT Pulse, Bruel & Kjaer multi analyser. The spectrums shown in the graphics demonstrate that they are within a frequency range of 0-1000Hz and 1600 lines, represent the vibratory speed.

TEST METHOD:

So as to know the isolation of the vibrations for each anti-vibratory phase, the sensors were placed in the following positions:

1. **Machine:** The objective is to know the nature of the vibrations of the machine, both their magnitude as well as frequency.
2. **Base of the support:** The objective is to know the vibratory isolation achieved by the spring.
3. **Floor:** The objective is to know the vibratory isolation achieved by Vibrabsorber + Sylomer[®].



INSTALLATION OF THE VIBRATION MEASUREMENT OF A REFRIGERATOR SET

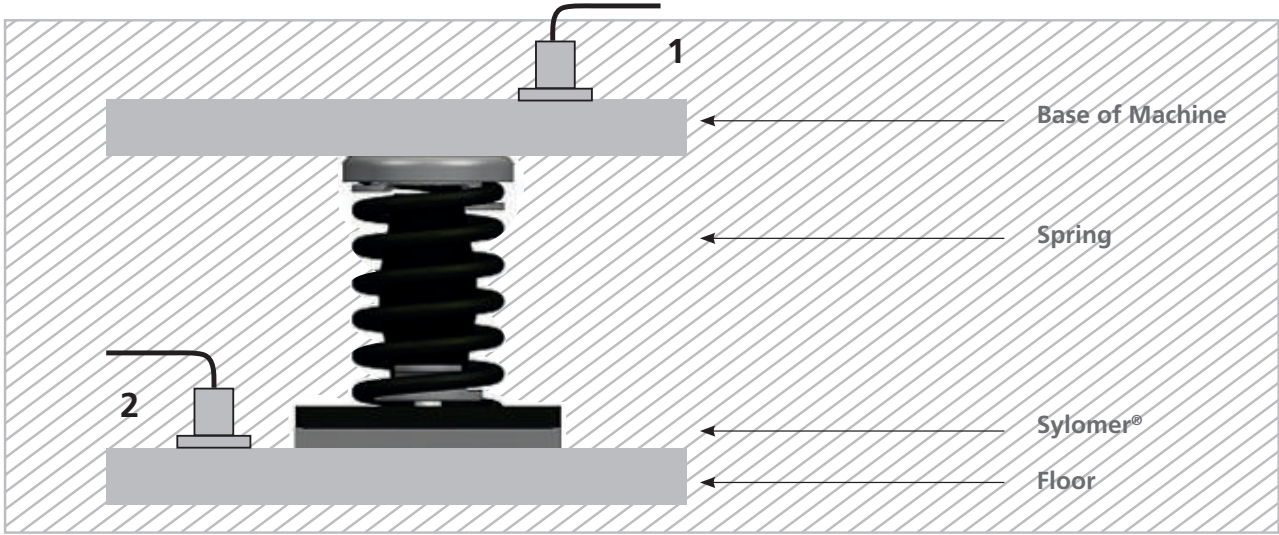

VIBRATION MEASUREMENT OF A REFRIGERATOR SET



1AMC 250



1AMC 250 + Sylomer® P12

VIBRATION MEASUREMENT

RESULTS:

FFT Pulse, Bruel & Kjaer multi analyser. The spectrums shown in the graphics demonstrate that they are within a frequency range of 0-1000Hz and 1600 lines, represent the vibratory speed.

1. Results on the Machine POINT 1:

The maximum vibration rms velocity is situated at 25Hz followed by another of lower magnitude at around 50 Hz. High frequency vibrations are also observed which correspond to harmonics and structural frequency responses from the machine.

2. Results on the Machine POINT 2 without Sylomer®:

In this graphic, a reduction can be observed in the predominant peaks. What is most noticeable is that frequencies above 200Hz are transmitted through the coils of the spring. These frequencies from 100 to 500 Hz are considered "audible" frequencies, meaning noise.

3. Results on the Machine POINT 2 with Sylomer®:

In this graphic, a reduction can be observed in all the peaks. The transmission of "noise" through the coils of the spring is reduced.

1. [m/s] Autospectrum (Motor velocity) – Point 1 and Working: Point 6z: Input: FFT Analyzer

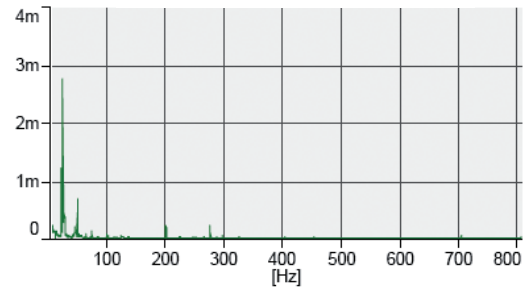

2. [m/s] Autospectrum (Chassis velocity) – Point 1 and Working: Point 6z: Input: FFT Analyzer

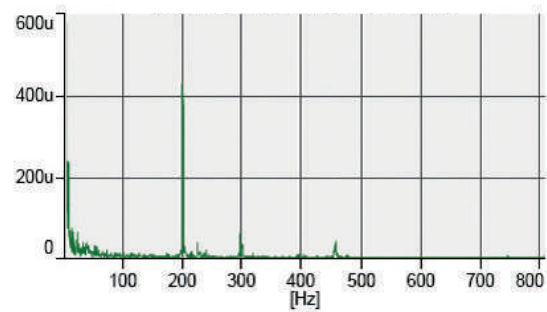

3. [m/s] Autospectrum (Chassis velocity) – Point 1 and Working: Point 6z: Input: FFT Analyzer

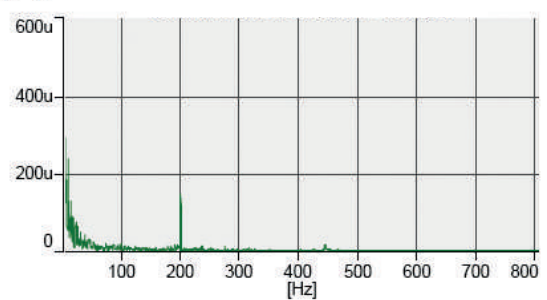

CONCLUSION

The air conditioning machines generate vibrations in a wide frequency spectrum. It is important that the anti-vibration supports are capable of isolating the low medium or high frequencies to the maximum. The Spring of the Vibrabsorbers is very effective for the low frequencies while Sylomer® is especially interesting to reduce medium and high vibration frequencies that are very relevant for the emission of structural noise.

Vibrabsorber by getzner + sylomer®

Vibrabsorber
by getzner
+ sylomer®



B Series

The B Series spring mounts are necessary in all machinery, which, by virtue of its design, has reciprocating or rotating parts, creates vibration to some degree through the imbalance of the moving parts.

This vibration produced by a machine leads to different problems, such as a reduction in the machine's useful life through part wear, plus the transmission of this vibration to other non-insulated adjacent structures, giving rise to problems of noise and vibration transmission. It is therefore important to install a spring mount to machinery.

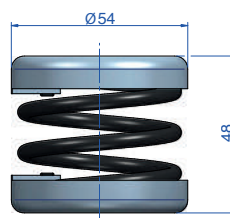
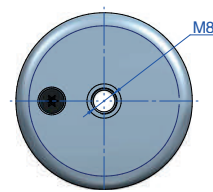

Type	Spring color	M	Max. Load (kg.)	Code	Weight (kg.)
AMC 10-B	BLACK	M-8	10	20171	0,2
AMC 25-B	BLACK	M-8	25	20173	0,205
AMC 50-B	BLACK	M-8	50	20175	0,254
AMC 75-B	BLACK	M-8	75	20177	0,26
AMC 100-B	BLACK	M-8	100	20179	0,29

DYNAMIC NATURAL FREQUENCY RANGE
AMC -MECANOCAUCHO® B SERIES

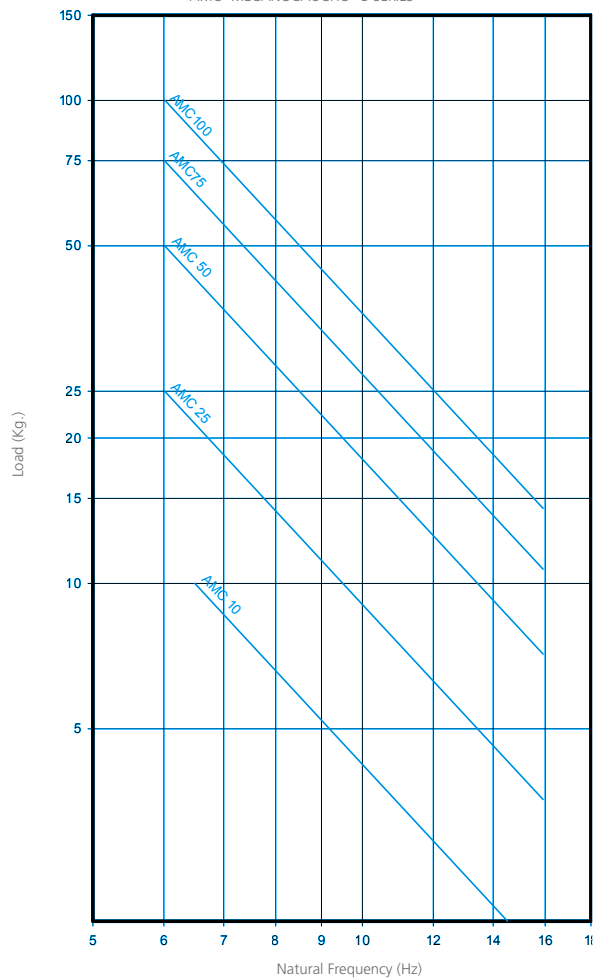

LOAD VS DEFLECTION DIAGRAM
AMC -MECANOCAUCHO® B SERIES

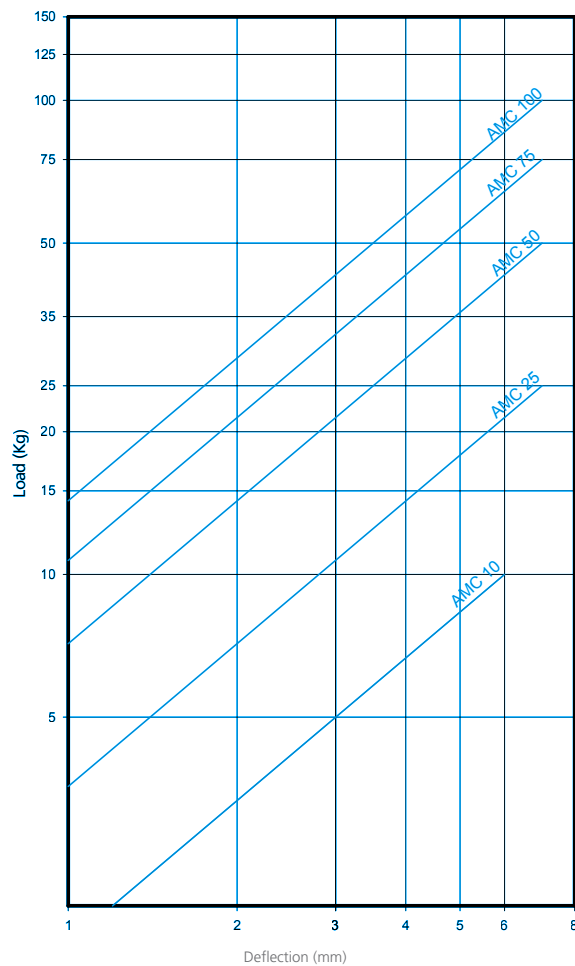

Medium Series

This is a range designed for the suspension of machinery operating at 500 rpm. The range of loads to be carried varies from 8 to 150 kg per support point.

Vibrabsorber

Type	Spring color	Max. Load (kg)	Weight (kg)	Code
AMC 15	BLACK	15	0,285	20126
AMC 25	BLACK	25	0,285	20101
AMC 50	BLUE	50	0,274	20103
AMC 75	GREY	75	0,298	20105
AMC 100	BEIGE	100	0,353	20107
AMC 125	WHITE	125	0,395	20300
AMC 150	BLACK	150	0,430	20303
Round rubber base	-	-	0,085	20109
Rectangular base	-	-	0,172	612014
Rectangular base+Sylomer®	-	-	0,200	20106

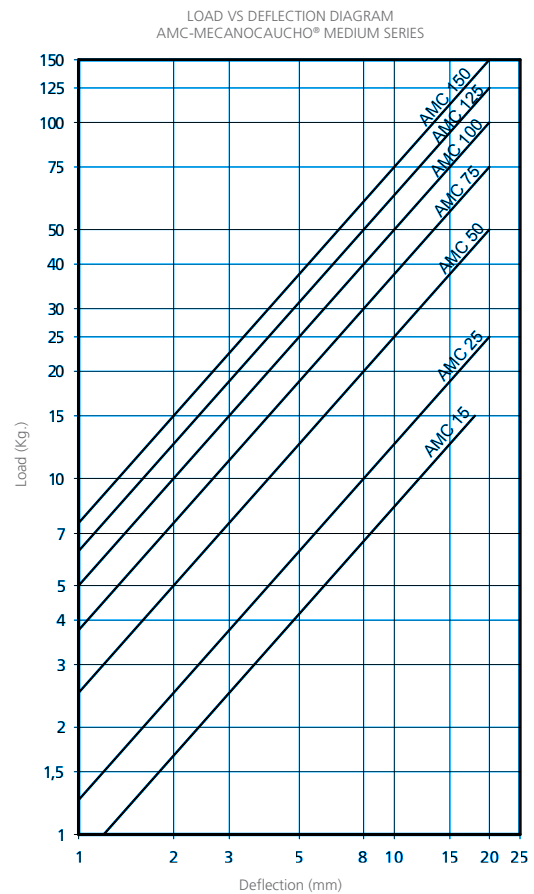
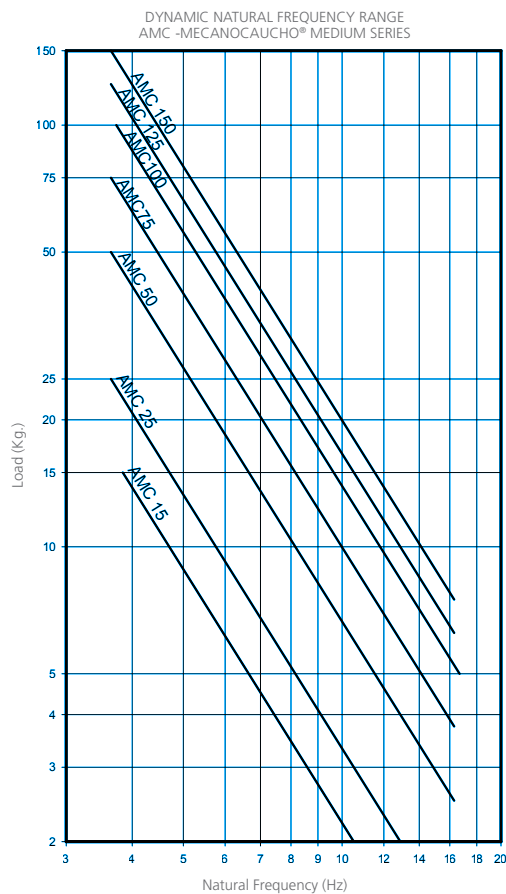
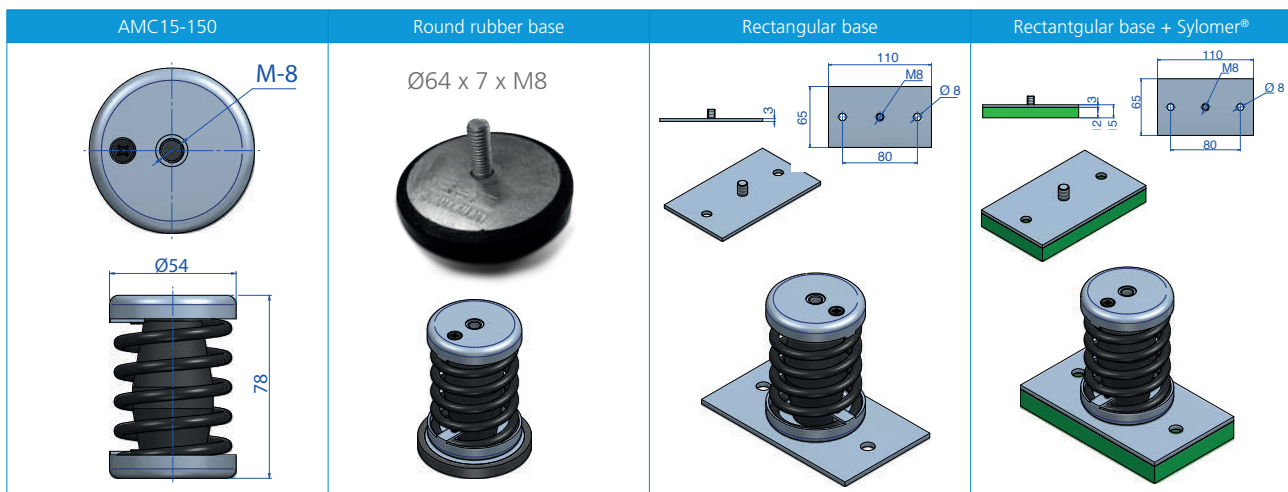

Bases

Using the medium series spring mounts together with these bases you can create your own spring mount sets yourself. Especially interesting for stockists that wish to keep low number of references in stock.

1AMC

Type	A (mm.)	B (mm.)	C (mm.)	D (mm.)	E (mm.)	Code	Weight (kg.)
Small	100	71	80	8,5	M-8	612034	0,189
Big	140	100	120	12	M-12	612035	0,341

2AMC

Type	A (mm.)	B (mm.)	C (mm.)	D (mm.)	Code	Weight (kg.)
Ø75	230	105	200	10,5	612029	0,64
Ø90	260	125	230	10,5	612031	0,791

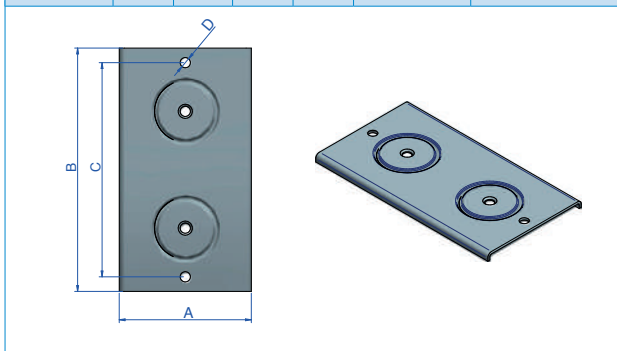

4AMC

Type	A (mm.)	B (mm.)	C (mm.)	D (mm.)	M	Code	Weight (kg.)
Ø75	210	205	186	10,5	M-16	612032	1,07
Ø90	250	230	230	10,5	M-16	612033	1,44
M12x25 Screw DIN7991 Allen						611278	0,026

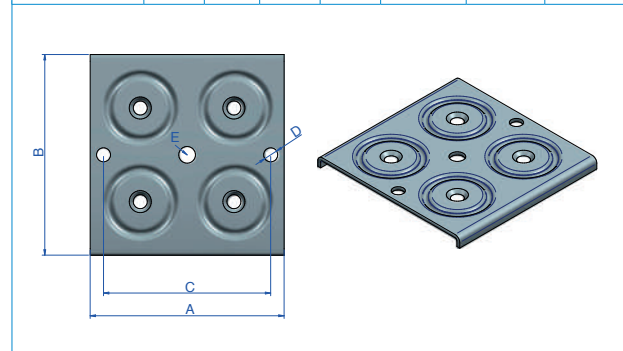

1 AMC Dual cup

With dual cup springs you can do yourself the installation of the springs.

Vibrabsorber

Type	A (mm.)	B (mm.)	Spring color	C (mm.)	Max. Load (kg.)	Code	Weight (kg.)
150	75	116	BLACK	M-12	150	20309	1,102
200	75	116	BLUE	M-12	200	20310	1,138
250	75	116	WHITE	M-12	250	20320	1,225
350	75	116	BLACK	M-12	350	20330	1,392
500	90	116	CREAM	M-12	500	20340	2,56
750	90	116	LIGHT GREY	M-12	750	20350	2,56

4 AMC T

The 4 AMC T spring mount is necessary in all machinery, which, by virtue of its design, has reciprocating or rotating parts, creates vibration to some degree through the imbalance of the moving parts. This vibration produced by a machine leads to different problems, such as a reduction in

the machine's useful life through part wear, plus the transmission of this vibration to other non-insulated adjacent structures, giving rise to problems of noise and vibration transmission. It is therefore important to install a spring mount to machinery.

Type	Spring color	LOAD Kg. MIN	LOAD Kg. MAX	Code	Weight (kg.)
4 AMC T-1	BLACK	40	100	20011	6,423
4 AMC T-2	BLUE	100	200	20012	6,645
4 AMC T-3	GREY	200	300	20013	6,899
4 AMC T-4	BEIGE	300	400	20014	6,954
4 AMC T-5	WHITE	400	500	20015	7,122

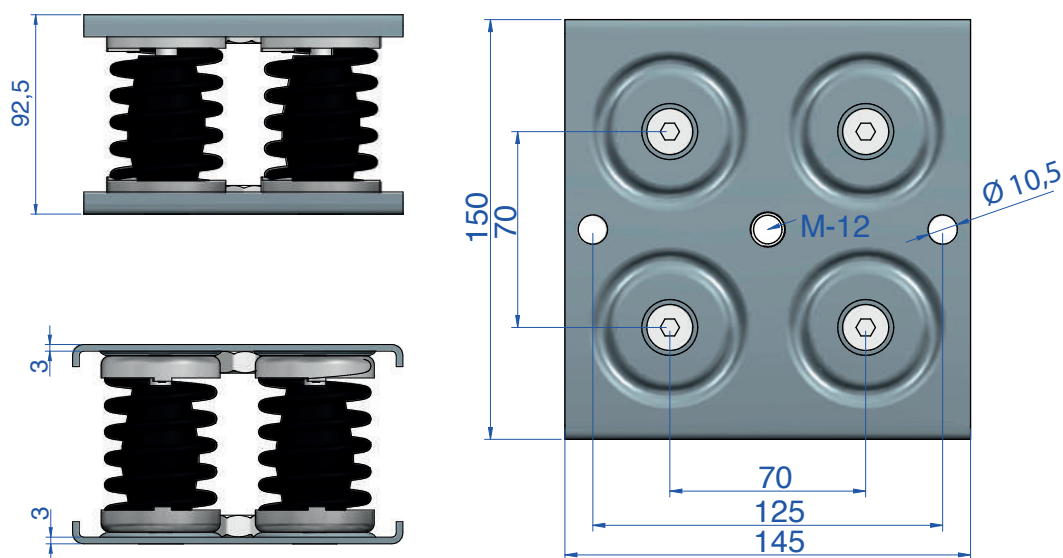

1 AMC

The 1 AMC spring mount is necessary in all machinery, which, by virtue of its design, has reciprocating or rotating parts, creates vibration to some degree through the imbalance of the moving parts. This vibration produced by a machine leads to different problems, such as a reduction in

the machine's useful life through part wear, plus the transmission of this vibration to other non-insulated adjacent structures, giving rise to problems of noise and vibration transmission. It is therefore important to install a spring mount to machinery.

Vibrabsorber + by getzner **sylomer**

Type	A (mm.)	B (mm.)	Spring color	C (mm.)	D (mm.)	E (mm.)	F (mm.)	G (mm.)	Max Load (kg.)	Code	Weight (kg.)
1 AMC 150 +Sylomer®	75	127	BLUE	M-12	100	120	12	140	150	20371	1,102
1 AMC 200 +Sylomer®	75	127	WHITE	M-12	100	120	12	140	200	20372	1,138
1 AMC 250 +Sylomer®	75	127	BLACK	M-12	100	120	12	140	250	20373	1,225
1 AMC 350 +Sylomer®	75	127	CREAM	M-12	100	120	12	140	350	20374	1,392
1 AMC 500 +Sylomer®	93	127	LIGHT GREY	M-14	100	120	12	140	500	20375	2,56
1 AMC 750 +Sylomer®	93	127	GREEN	M-14	100	120	12	140	750	20376	3,036

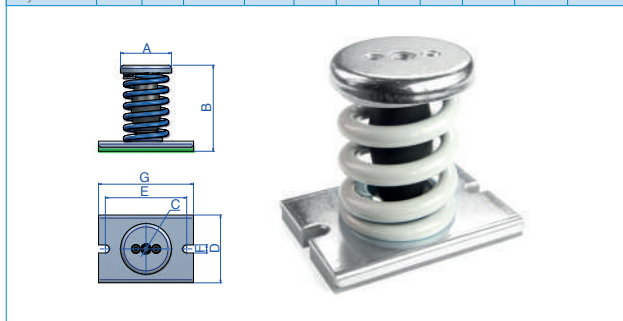

Vibrabsorber

Type	A (mm.)	B (mm.)	Spring color	C (mm.)	D (mm.)	E (mm.)	F (mm.)	G (mm.)	Max Load (kg.)	Code	Weight (kg.)
1 AMC 150	75	122	BLUE	M-12	80	87	10	115	150	20301	1,102
1 AMC 200	75	122	WHITE	M-12	80	87	10	115	200	20311	1,138
1 AMC 250	75	122	BLACK	M-12	80	87	10	115	250	20321	1,225
1 AMC 350	75	122	CREAM	M-12	80	87	10	115	350	20331	1,392
1 AMC 500	93	120	LIGHT GREY	M-14	100	120	12	150	500	20341	2,56
1 AMC 750	93	120	GREEN	M-14	100	120	12	150	750	20351	3,036

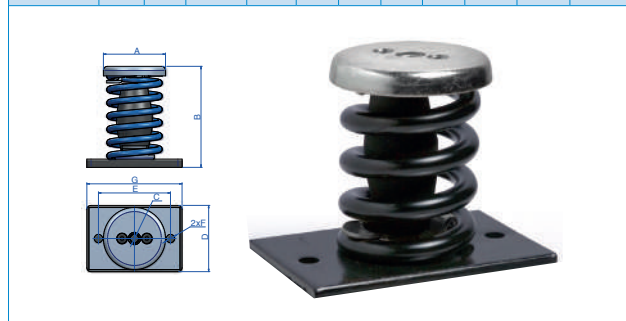

DYNAMIC NATURAL FREQUENCY RANGE
AMC-MECANOCAUCHO® 1 AMC

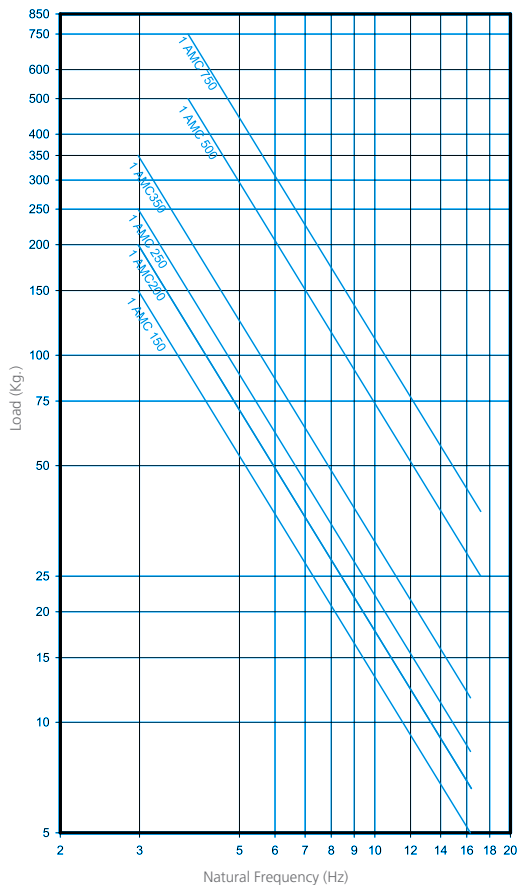

LOAD VS DEFLECTION DIAGRAM
AMC-MECANOCAUCHO® 1 AMC

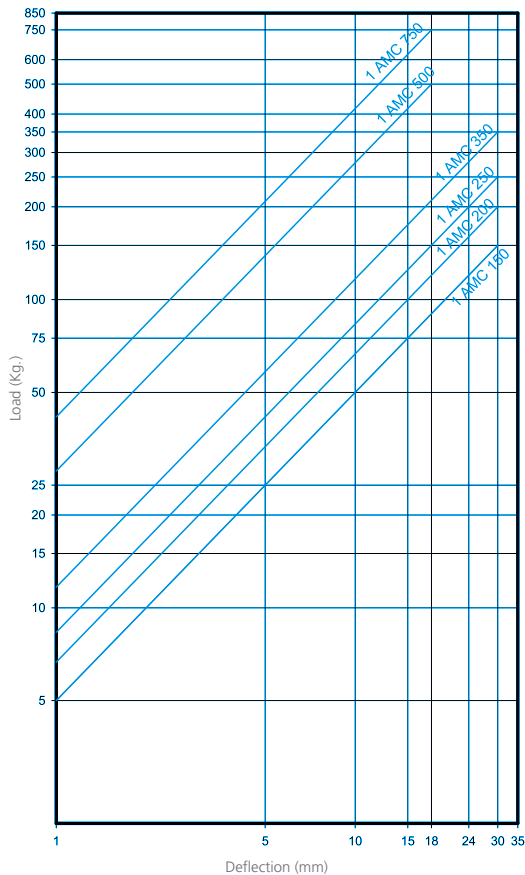

2 AMC

The 2 AMC spring mount is necessary in all machinery, which, by virtue of its design, has reciprocating or rotating parts, creates vibration to some degree through the imbalance of the moving parts. This vibration produced by a machine leads to different problems, such as a reduction in

the machine's useful life through part wear, plus the transmission of this vibration to other non-insulated adjacent structures, giving rise to problems of noise and vibration transmission. It is therefore important to install a spring mount to machinery.

Vibrabsorber + **sylomer**[®]

Type	A (mm.)	B (mm.)	Spring color	C (mm.)	D (mm.)	E (mm.)	F (mm.)	G (mm.)	H (mm.)	Max. Load (kg.)	Code	Weight (kg.)
2 AMC 300 +Sylomer [®]	200	136	BLUE	75	12	170	220	244	81	300	20471	3,1
2 AMC 400 +Sylomer [®]	200	136	WHITE	75	12	170	220	244	81	400	20472	3,172
2 AMC 500 +Sylomer [®]	200	136	BLACK	75	12	170	220	244	81	500	20473	3,348
2 AMC 700 +Sylomer [®]	200	136	CREAM	75	12	170	220	244	81	700	20474	3,7
2 AMC 1000 +Sylomer [®]	250	136	LIGHT GREY	100	14	210	270	298	106	1000	20475	5,9
2 AMC 1500 +Sylomer [®]	250	136	GREEN	100	14	210	270	298	106	1500	20476	6,844

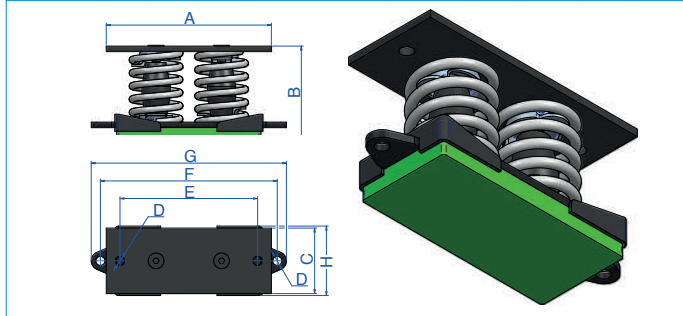

Vibrabsorber

Type	A (mm.)	B (mm.)	Spring color	C (mm.)	D (mm.)	E (mm.)	Max. Load (kg.)	Code	Weight (kg.)
2 AMC 300	200	124	BLUE	75	12	170	300	20401	3,1
2 AMC 400	200	124	WHITE	75	12	170	400	20411	3,172
2 AMC 500	200	124	BLACK	75	12	170	500	20421	3,348
2 AMC 700	200	124	CREAM	75	12	170	700	20431	3,7
2 AMC 1.000	250	124	LIGHT GREY	100	14	210	1000	20441	5,9
2 AMC 1.500	250	124	GREEN	100	14	210	1500	20451	6,844

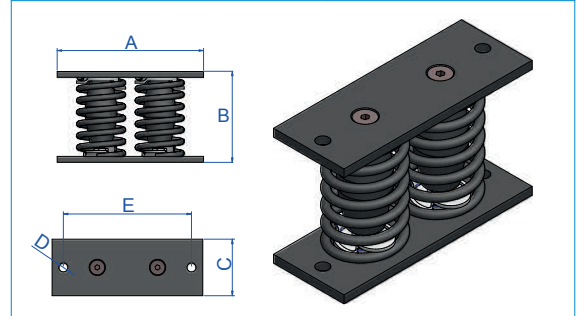

DYNAMIC NATURAL FREQUENCY RANGE
AMC -MECANOCAUCHO® 2 AMC

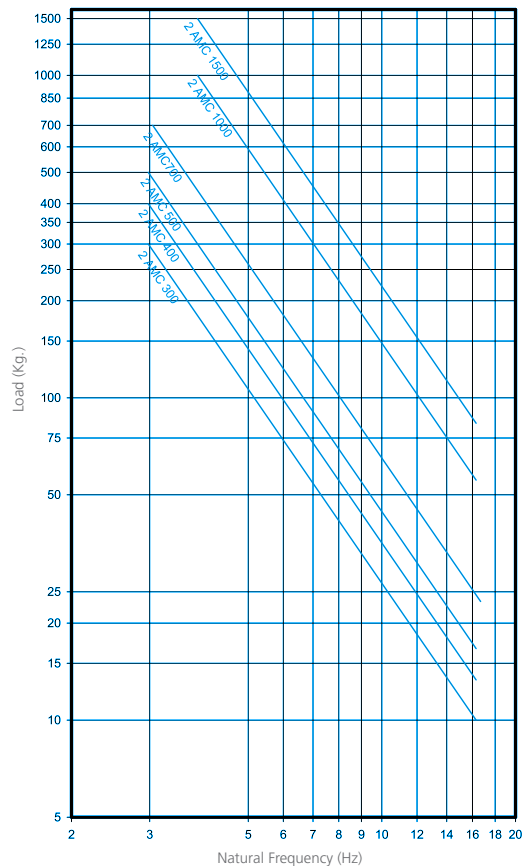

LOAD VS DEFLECTION DIAGRAM
AMC-MECANOCAUCHO® 2 AMC

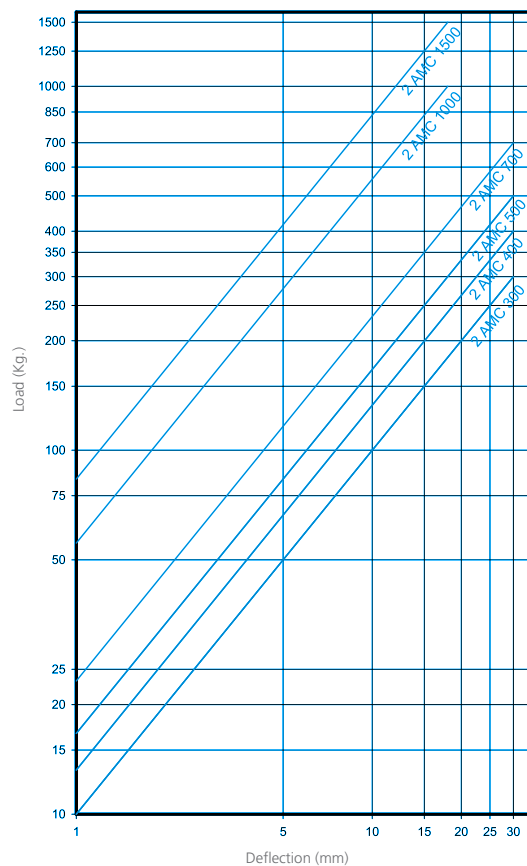

3 AMC

The 3 AMC spring mount is necessary in all machinery, which, by virtue of its design, has reciprocating or rotating parts, creates vibration to some degree through the imbalance of the moving parts. This vibration produced by a machine leads to different problems, such as a reduction in

the machine's useful life through part wear, plus the transmission of this vibration to other non-insulated adjacent structures, giving rise to problems of noise and vibration transmission. It is therefore important to install a spring mount to machinery.

Vibrabsorber + sylomer®

Type	A (mm.)	B (mm.)	Spring color	C (mm.)	D (mm.)	E (mm.)	F (mm.)	G (mm.)	H (mm.)	I (mm.)	Max. Load (kg.)	Code	Weight (kg.)
3 AMC 450 +Sylomer®	196,3	136	BLUE	M-16	12	180	176	207,7	110	201,4	450	20571	4,6
3 AMC 600 +Sylomer®	196,3	136	WHITE	M-16	12	180	176	207,7	110	201,4	600	20572	4,714
3 AMC 750 +Sylomer®	196,3	136	BLACK	M-16	12	180	176	207,7	110	201,4	750	20573	4,978
3 AMC 1050 +Sylomer®	196,3	136	CREAM	M-16	12	180	176	207,7	110	201,4	1050	20574	5,524
3 AMC 1500 +Sylomer®	246	136	LIGHT GREY	M-20	14	220	219	255,7	136	251	1500	20575	8,564
3 AMC 2250 +Sylomer®	246	136	GREEN	M-20	14	220	219	255,7	136	251	2250	20576	9,964

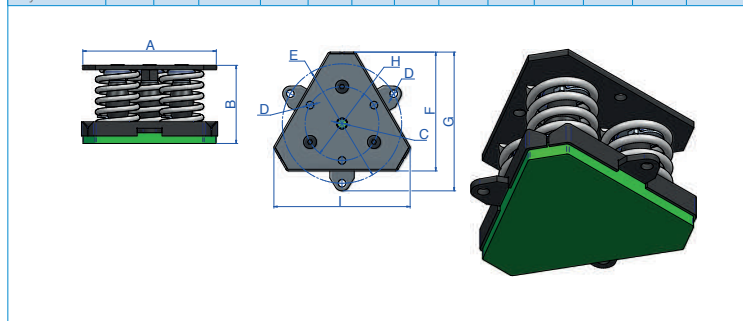

DYNAMIC NATURAL FREQUENCY RANGE
AMC -MECANOCAUCHO® 3 AMC

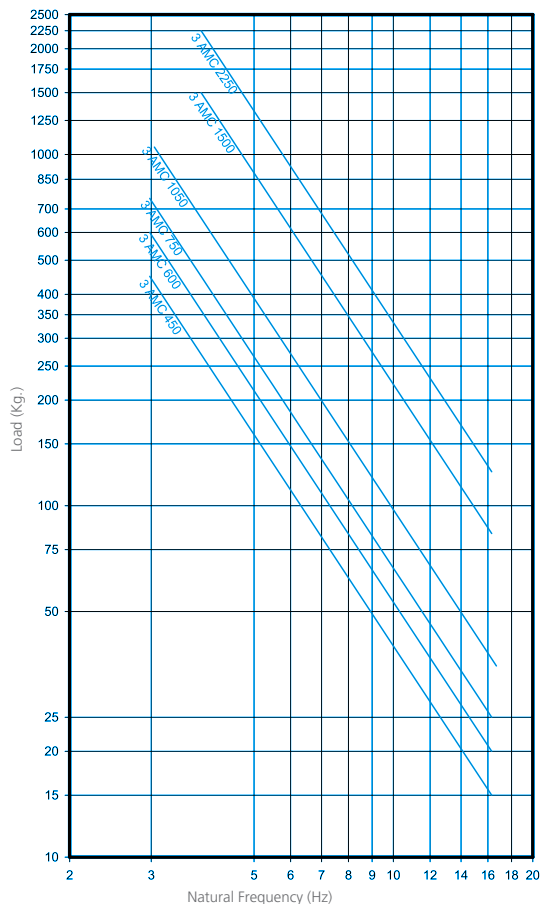

Vibrabsorber

Type	A (mm.)	B (mm.)	Spring color	C (mm.)	D (mm.)	Max. Load (kg.)	Code	Weight (kg.)
3 AMC 450	196,3	124	BLUE	M-16	12	450	20501	4,6
3 AMC 600	196,3	124	WHITE	M-16	12	600	20511	4,714
3 AMC 750	196,3	124	BLACK	M-16	12	750	20521	4,978
3 AMC 1050	196,3	124	CREAM	M-16	12	1050	20531	5,524
3 AMC 1500	242	124	LIGHT GREY	M-20	14	1500	20541	8,564
3 AMC 2250	242	124	GREEN	M-20	14	2250	20551	9,964

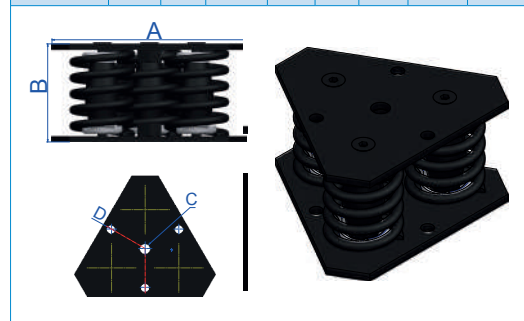

LOAD VS DEFLECTION DIAGRAM
AMC -MECANOCAUCHO® 3 AMC

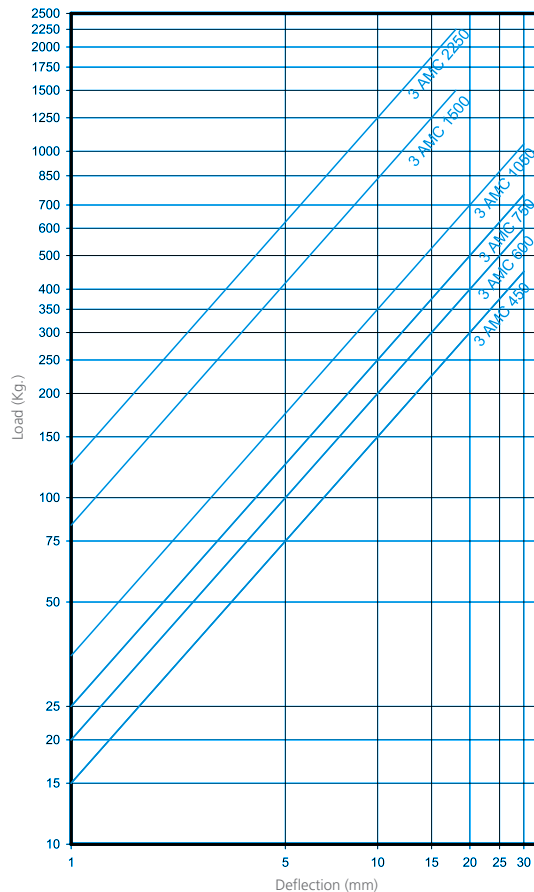

4 AMC

The 4 AMC spring mount is necessary in all machinery, which, by virtue of its design, has reciprocating or rotating parts, creates vibration to some degree through the imbalance of the moving parts. This vibration produced by a machine leads to different problems, such as a reduction in

the machine's useful life through part wear, plus the transmission of this vibration to other non-insulated adjacent structures, giving rise to problems of noise and vibration transmission. It is therefore important to install a spring mount to machinery.

Vibrabsorber + **sylomer**[®]

Type	A (mm.)	B (mm.)	Spring color	C (mm.)	D (mm.)	E (mm.)	F (mm.)	G (mm.)	H (mm.)	I (mm.)	Max Load (kg.)	Code	Weight (kg.)
4 AMC 600 +Sylomer [®]	200	136	BLUE	M-16	150	12	170	190	214	156	600	20671	6,412
4 AMC 800 +Sylomer [®]	200	136	WHITE	M-16	150	12	170	190	214	156	800	20672	6,572
4 AMC 1000 +Sylomer [®]	200	136	BLACK	M-16	150	12	170	190	214	156	1000	20673	6,7
4 AMC 1400 +Sylomer [®]	200	136	CREAM	M-16	150	12	170	190	214	156	1400	20674	7,636
4 AMC 2000 +Sylomer [®]	250	136	LIGHT GREY	M-20	200	14	210	260	288	206	2000	20675	12,1
4 AMC 3000 +Sylomer [®]	250	136	GREEN	M-20	200	14	210	260	288	206	3000	20676	13,962

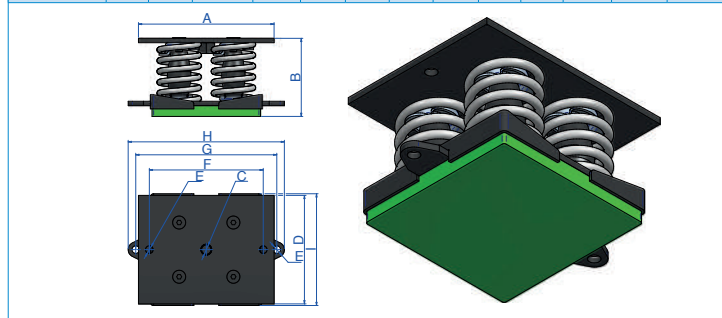

Vibrabsorber

Type	A (mm.)	B (mm.)	Spring color	C (mm.)	D (mm.)	E (mm.)	F (mm.)	Max Load (kg.)	Code	Weight (kg.)
4 AMC 600	200	124	BLUE	M-16	150	12	170	600	20601	6,412
4 AMC 800	200	124	WHITE	M-16	150	12	170	800	20611	6,572
4 AMC 1000	200	124	BLACK	M-16	150	12	170	1000	20621	6,7
4 AMC 1400	200	124	CREAM	M-16	150	12	170	1400	20631	7,636
4 AMC 2000	250	124	LIGHT GREY	M-20	200	14	210	2000	20641	12,1
4 AMC 3000	250	124	GREEN	M-20	200	14	210	3000	20651	13,962

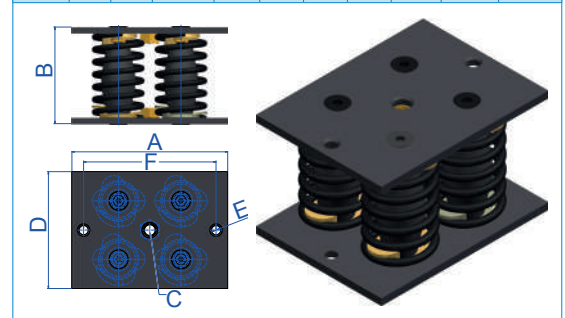

DYNAMIC NATURAL FREQUENCY RANGE
AMC-MECANOCAUCHO® 4 AMC

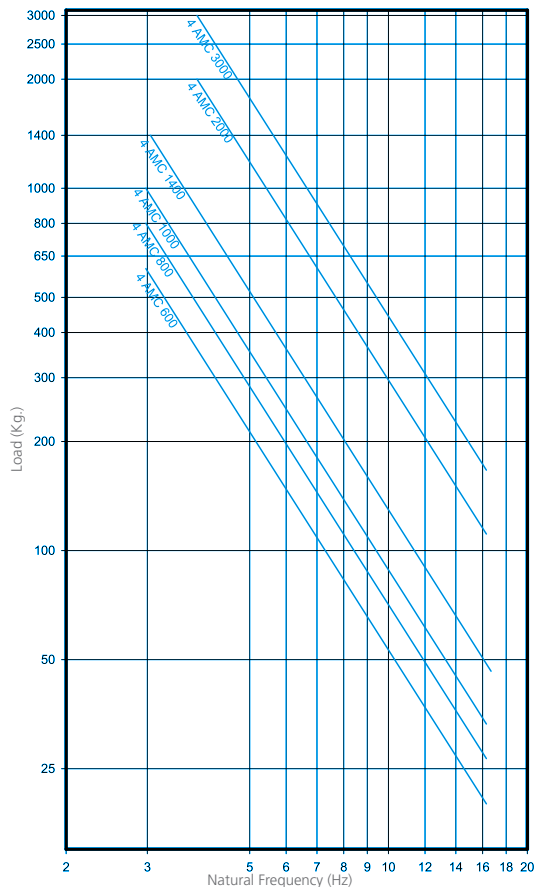

LOAD VS DEFLECTION DIAGRAM
AMC-MECANOCAUCHO® 4 AMC

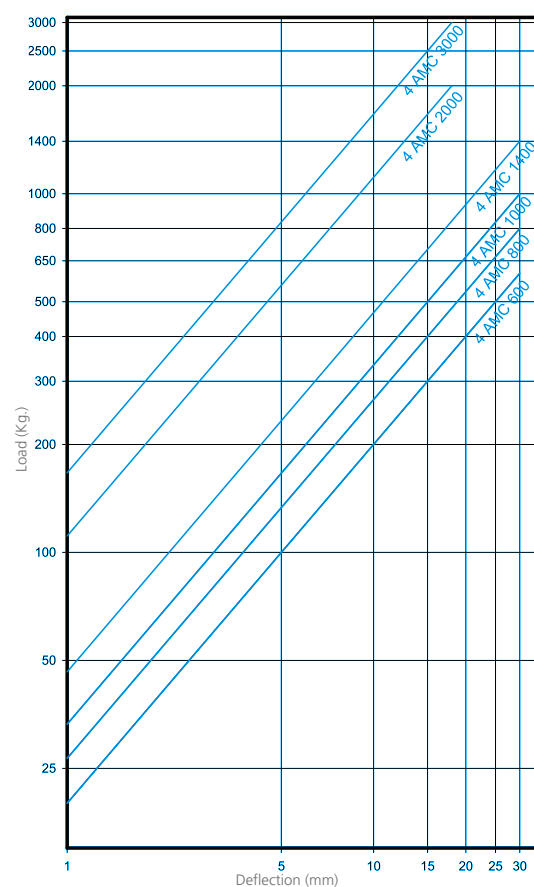

5 AMC

The 5 AMC spring mount is necessary in all machinery, which, by virtue of its design, has reciprocating or rotating parts, creates vibration to some degree through the imbalance of the moving parts. This vibration produced by a machine leads to different problems, such as a reduction in

the machine's useful life through part wear, plus the transmission of this vibration to other non-insulated adjacent structures, giving rise to problems of noise and vibration transmission. It is therefore important to install a spring mount to machinery.

Vibrabsorber + sylomer® by getzner

Type	A (mm.)	B (mm.)	Spring color	C (mm.)	D (mm.)	E (mm.)	F (mm.)	G (mm.)	H (mm.)	Max Load (kg.)	Code	Weight (kg.)
5 AMC 750 +Sylomer®	280	136	BLUE	150	16	251	290	322	156	750	20771	8,502
5 AMC 1000 +Sylomer®	280	136	WHITE	150	16	251	290	322	156	1000	20772	8,692
5 AMC 1250 +Sylomer®	280	136	BLACK	150	16	251	290	322	156	1250	20773	9,162
5 AMC 1750 +Sylomer®	280	136	CREAM	150	16	251	290	322	156	1750	20774	10,037
5 AMC 2500 +Sylomer®	350	136	LIGHT GREY	200	18	315	360	396	206	2500	20775	15,716
5 AMC 3750 +Sylomer®	350	136	GREEN	200	18	315	360	396	206	3750	20776	18,056

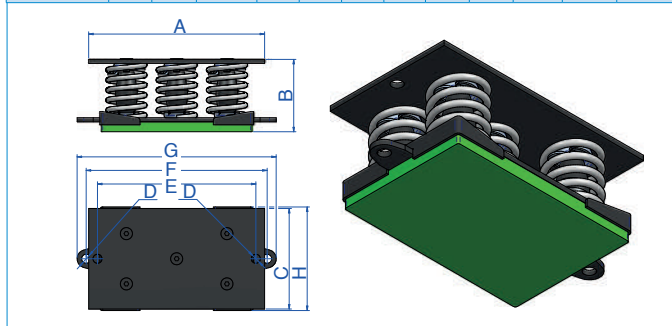

DYNAMIC NATURAL FREQUENCY RANGE
AMC-MECANOCAUCHO® 5 AMC

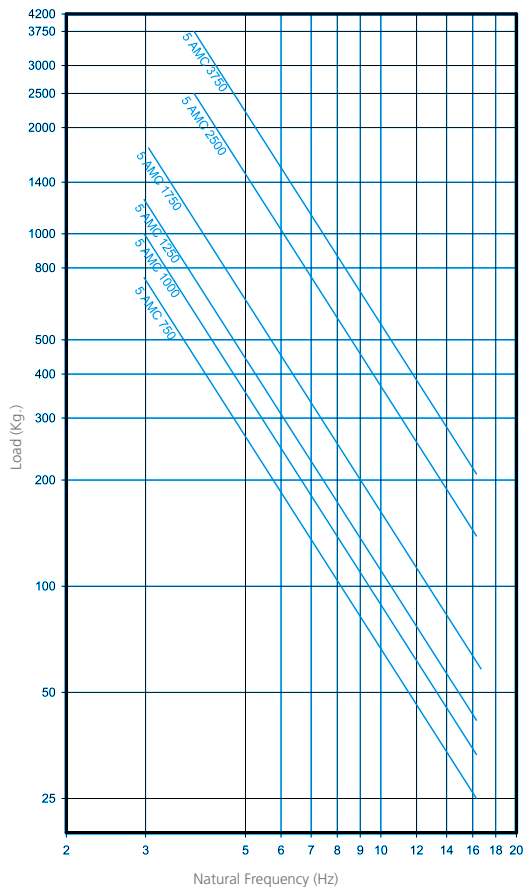

Vibrabsorber

Type	A (mm.)	B (mm.)	Spring color	C (mm.)	D (mm.)	E (mm.)	Max Load (kg.)	Code	Weight (kg.)
5 AMC 750	280	124	BLUE	150	16	251	750	20701	8,502
5 AMC 1.000	280	124	WHITE	150	16	251	1000	20711	8,692
5 AMC 1.250	280	124	BLACK	150	16	251	1250	20721	9,162
5 AMC 1.750	280	124	CREAM	150	16	251	1750	20731	10,037
5 AMC 2.500	350	124	LIGHT GREY	200	18	315	2500	20741	15,716
5 AMC 3.750	350	124	GREEN	200	18	315	3750	20751	18,056

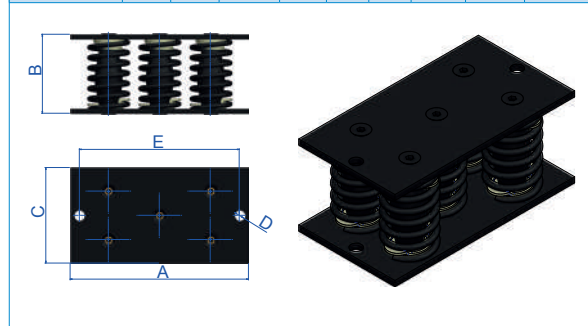

LOAD VS DEFLECTION DIAGRAM
AMC-MECANOCAUCHO® 5 AMC

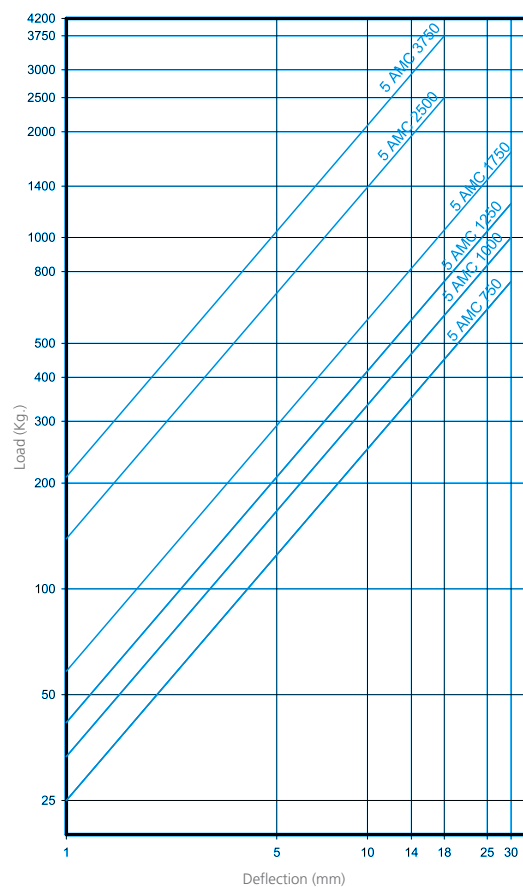

6 AMC

The 6 AMC spring mount is necessary in all machinery, which, by virtue of its design, has reciprocating or rotating parts, creates vibration to some degree through the imbalance of the moving parts. This vibration produced by a machine leads to different problems, such as a reduction in

the machine's useful life through part wear, plus the transmission of this vibration to other non-insulated adjacent structures, giving rise to problems of noise and vibration transmission. It is therefore important to install a spring mount to machinery.

Vibrabsorber + **sylomer**[®] by getzner

Type	A (mm.)	B (mm.)	Spring color	C (mm.)	D (mm.)	E (mm.)	F (mm.)	G (mm.)	H (mm.)	Max. Load (kg.)	Code	Weight (kg.)
6 AMC 900 +Sylomer [®]	280	136	BLUE	150	16	248	290	322	156	900	20871	8,928
6 AMC 1200 +Sylomer [®]	280	136	WHITE	150	16	248	290	322	156	1200	20872	9,156
6 AMC 1500 +Sylomer [®]	280	136	BLACK	150	16	248	290	322	156	1500	20873	9,684
6 AMC 2100 +Sylomer [®]	280	136	CREAM	150	16	248	290	322	156	2100	20874	10,77
6 AMC 3000 +Sylomer [®]	350	136	LIGHT GREY	200	18	300	360	396	206	3000	20875	16,848
6 AMC 4500 +Sylomer [®]	350	136	GREEN	200	18	300	360	396	206	4500	20876	19,656

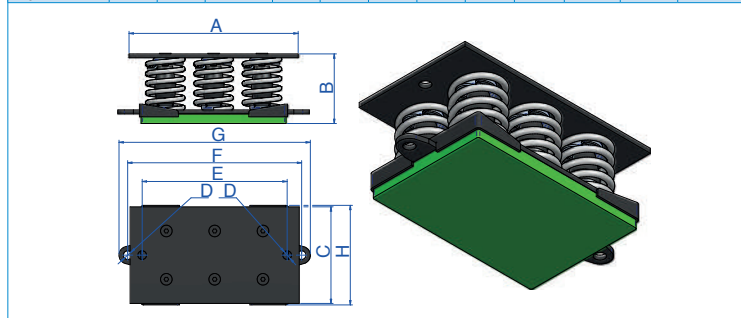

Vibrabsorber

Type	A (mm.)	B (mm.)	Spring color	C (mm.)	D (mm.)	H (mm.)	Max. Load (kg.)	Code	Weight (kg.)
6 AMC 900	280	124	BLUE	150	16	251	900	20801	8,928
6 AMC 1.200	280	124	WHITE	150	16	251	1200	20811	9,156
6 AMC 1.500	280	124	BLACK	150	16	251	1500	20821	9,684
6 AMC 2.100	280	124	CREAM	150	16	251	2100	20831	10,77
6 AMC 3.000	350	124	LIGHT GREY	200	18	300	3000	20841	16,848
6 AMC 4.500	350	124	GREEN	200	18	300	4500	20851	19,656

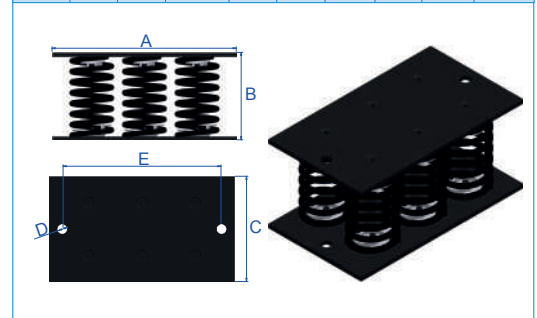

DYNAMIC NATURAL FREQUENCY RANGE
AMC-MECANOCACHO[®] 6 AMC

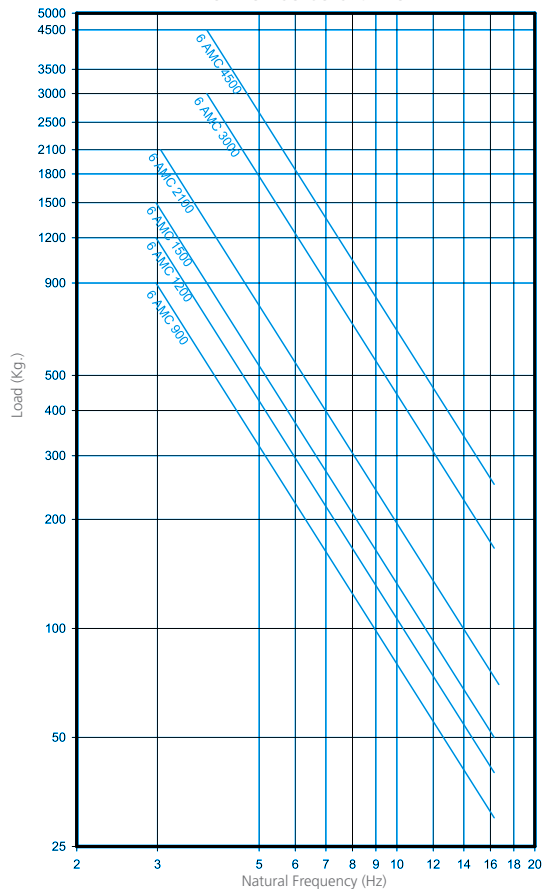

LOAD VS DEFLECTION DIAGRAM
AMC-MECANOCACHO[®] 6 AMC

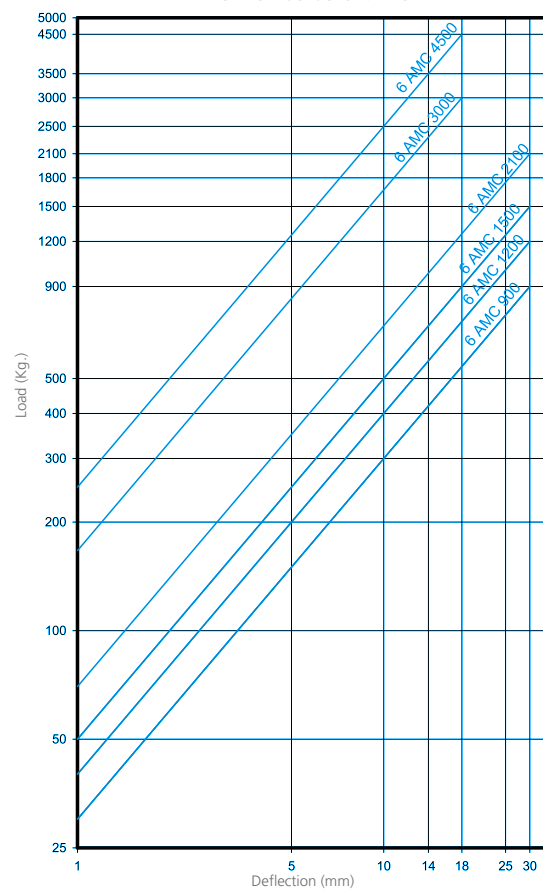

9 AMC

The 9 AMC spring mount is necessary in all machinery, which, by virtue of its design, has reciprocating or rotating parts, creates vibration to some degree through the imbalance of the moving parts. This vibration produced by a machine leads to different problems, such as a reduction in

the machine's useful life through part wear, plus the transmission of this vibration to other non-insulated adjacent structures, giving rise to problems of noise and vibration transmission. It is therefore important to install a spring mount to machinery.

Vibrabsorber + by getzner **sylomer®**

Type	A (mm.)	B (mm.)	Spring color	C (mm.)	D (mm.)	E (mm.)	F (mm.)	G (mm.)	H (mm.)	I (mm.)	Max. Load (kg.)	Code	Weight (kg.)
9 AMC 1350 +Sylomer®	280	136	BLUE	226	16	248	290	322	232	75	1350	20971	13,702
9 AMC 1800 +Sylomer®	280	136	WHITE	226	16	248	290	322	232	75	1800	20972	14,044
9 AMC 2250 +Sylomer®	280	136	BLACK	226	16	248	290	322	232	75	2250	20973	14,836
9 AMC 3150 +Sylomer®	280	136	CREAM	226	16	248	290	322	232	75	3150	20974	16,465
9 AMC 4500 +Sylomer®	350	136	LIGHT GREY	300	18	310	360	396	306	100	4500	20975	27,547
9 AMC 6750 +Sylomer®	350	136	GREEN	300	18	310	360	396	306	100	6750	20976	31,75

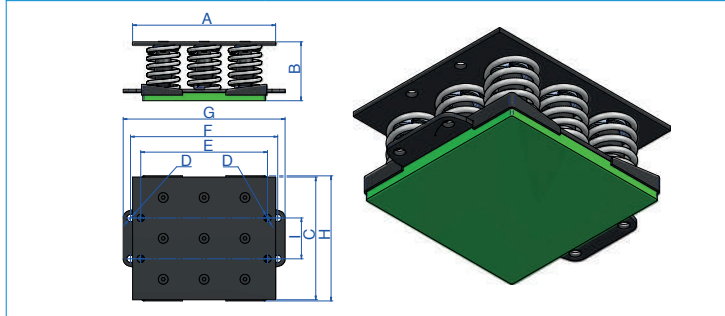

Vibrabsorber

Type	A (mm.)	B (mm.)	Spring color	C (mm.)	D (mm.)	E (mm.)	Max. Load (kg.)	Code	Weight (kg.)
9 AMC 1.350	280	124	BLUE	226	16	248	1350	20901	13,702
9 AMC 1.800	280	124	WHITE	226	16	248	1800	20911	14,044
9 AMC 2.250	280	124	BLACK	226	16	248	2250	20921	14,836
9 AMC 3.150	280	124	CREAM	226	16	248	3150	20931	16,465
9 AMC 4.500	350	124	LIGHT GREY	300	18	310	4500	20941	27,547
9 AMC 6.750	350	124	GREEN	300	18	310	6750	20951	31,75

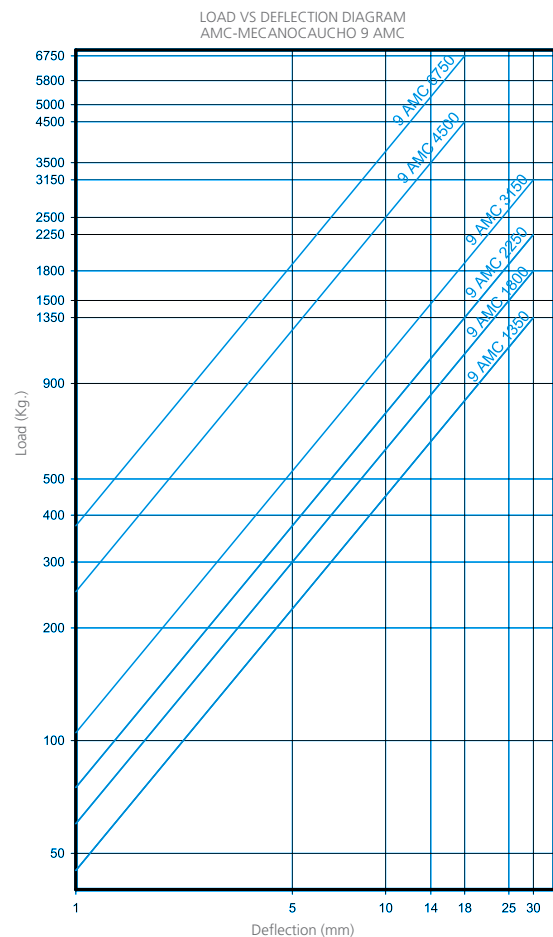
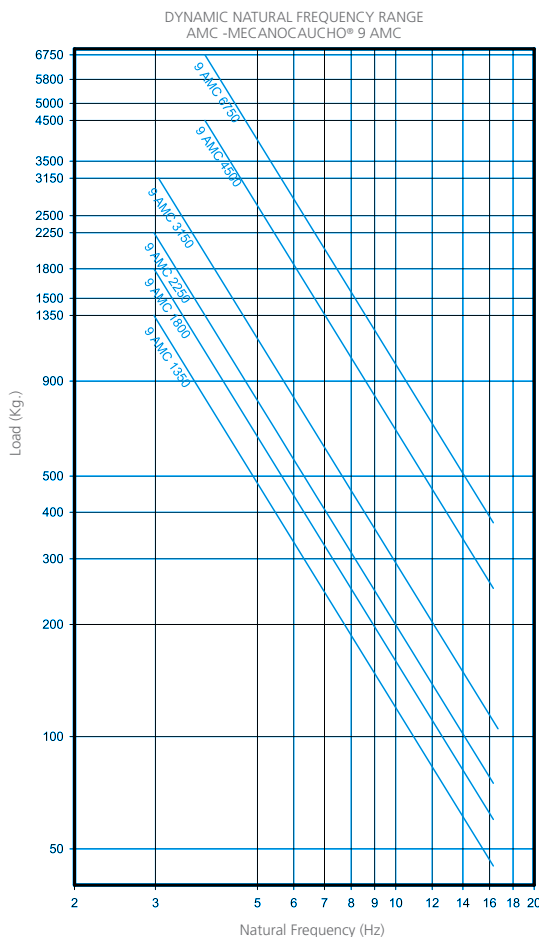
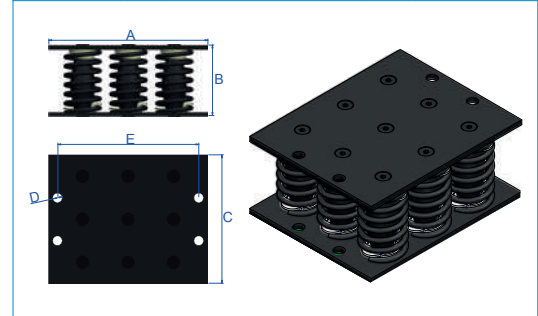

PS+SYLOMER® SPRING-MOUNTS

The new Vibrabsorber PS+Sylomer® are spring mounts for anti-vibration purposes that have the capability to be pre-loaded. Thanks to the design of their metal parts, the Vibrabsorber PS+Sylomer® spring-mounts allow to add a pre stress on the anti-vibration mount.

the anti-vibration mount must not exceed a certain height either for the installation or during the maintenance of the machine when liquids are extracted and the mount must not exceed a certain height. Thanks to their low stiffness, they are often used on applications where a high isolation degree is required at low disturbing frequencies (600 to 1000 rpm).

The AMC-MECANOCAUCHO® type Vibrabsorber PS+Sylomer® are ideal for stationary applications where

Ps+Sylomer® 1 AMC Preload

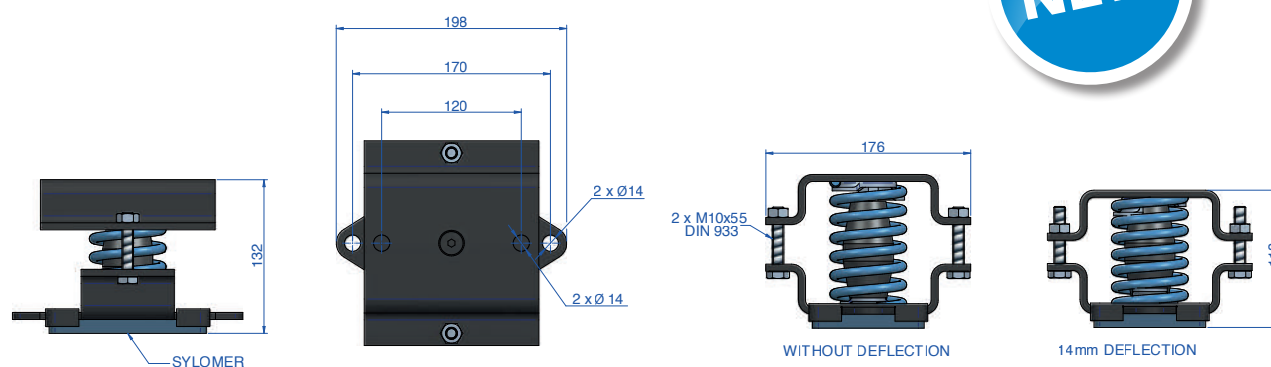

Type	Spring color	Max. Load (kg)	Weight (kg)	Code
1 AMC 150	BLUE	150	1,138	20522
1 AMC 200	WHITE	200	1,138	20523
1 AMC 250	BLACK	250	1,138	20524
1 AMC 350	CREAM	350	1,138	20525
1 AMC 500	LIGHT GREY	500	1,138	20526
1 AMC 750	GREEN	750	1,138	20527

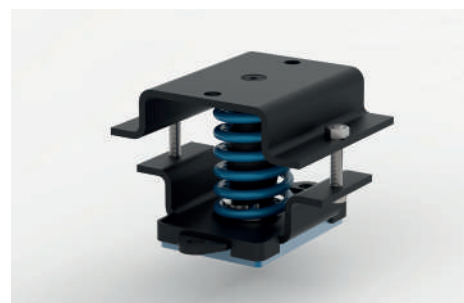

Ps+Sylomer® 2 AMC Preload

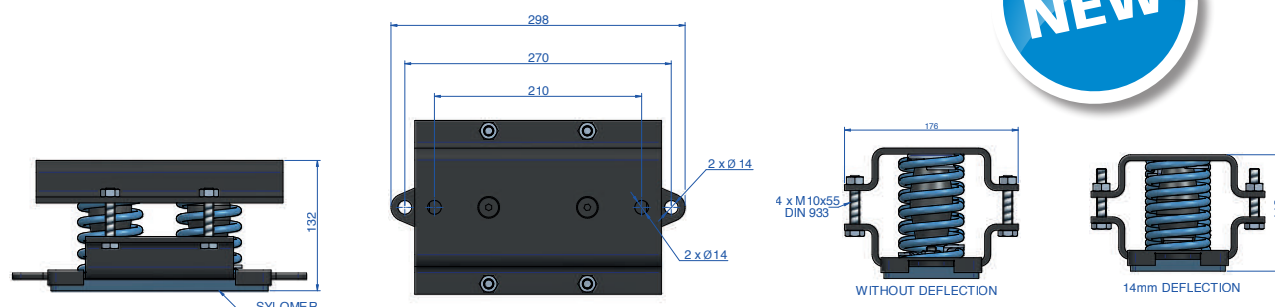

Type	Spring color	Max. Load (kg)	Weight (kg)	Code
2 AMC 300	BLUE	300	6,7	20532
2 AMC 400	WHITE	400	6,8	20533
2 AMC 500	BLACK	500	7	20534
2 AMC 700	CREAM	700	7,2	20535
2 AMC 1000	LIGHT GREY	1000	7,8	20536
2 AMC 1500	GREEN	1500	8,3	20537

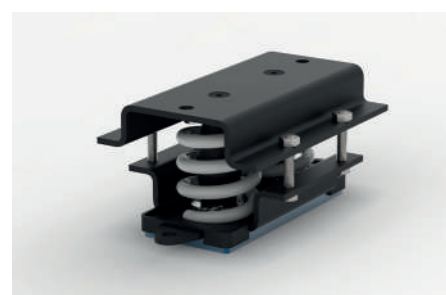

VT

The VT range is designed for suspension of suspended acoustic ceilings and machinery operating at more than 450 r.p.m. These isolators are made of piano tail spring quality with a high mechanical performance. They incorporate rubber bush conceived to avoid the "acoustic bridges" and the contact of a non aligned screw. The metallic structure is very robust and it is supplied with an anti-corrosive zinc-plated coat.



Type	MAX PERMANENT LOAD	Spring color	A (mm)	C (mm)	D (mm)	H (mm)	M	Weight (kg)	Code
VT 15	15	BLACK	80	12	50	120	M-8	0,71	20200
VT 25	25	BLACK	80	12	50	120	M-8	0,71	20201
VT 50	50	BLUE	80	12	50	120	M-8	0,7	20202
VT 75	75	GREY	80	12	50	120	M-8	0,72	20203
VT 100	100	BEIGE	80	12	50	120	M-8	0,778	20204
VT 125	125	WHITE	80	12	50	120	M-8	1,102	20211
VT 150R	150	BLACK	80	12	50	120	M-8	0,77	20224
VT 150	150	BLUE	120	16	80	160	M-12	2,035	20205
VT 200	200	WHITE	120	16	80	160	M-12	2,072	20210
VT 250	250	BLACK	120	16	80	160	M-12	2,148	20206
VT 350	350	CREAM	120	16	80	160	M-12	2,33	20207
VT 500	500	LIGHT GREY	140	16	100	180	M-14	4,785	20208
VT 750	750	GREEN	140	16	100	180	M-14	5,249	20209

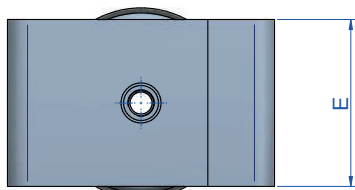
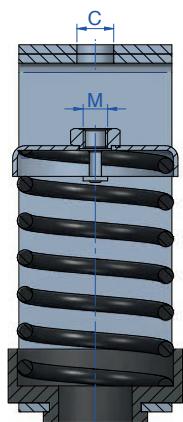
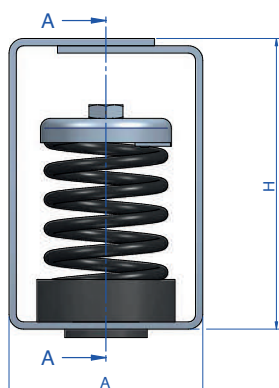

LOAD DEFLECTION CURVES
VT 15 - VT 150R HANGERS

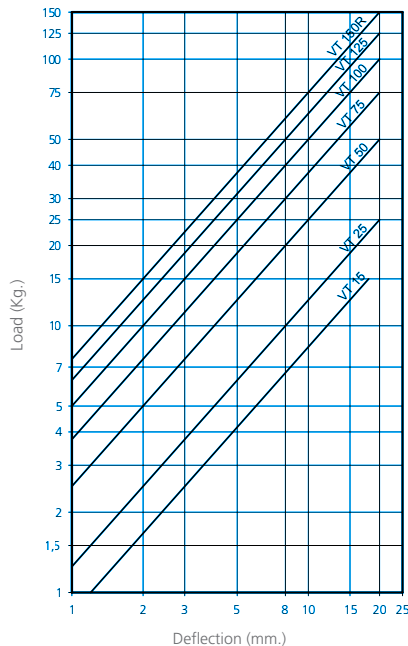

LOAD DEFLECTION CURVES
VT 150 - VT 750 HANGERS

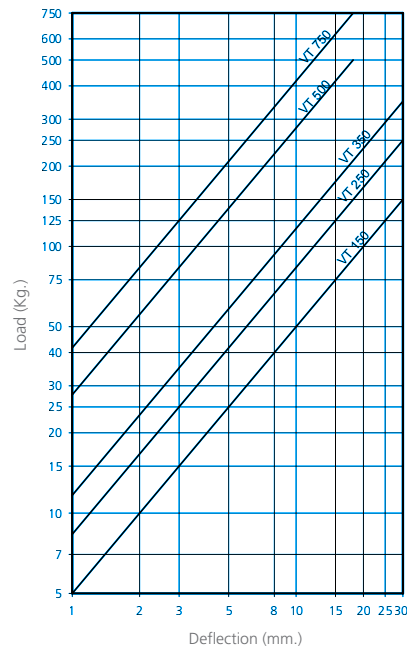

VT-HD

The metallic structure is very robust and it is supplied with an anti-corrosive zinc-plated coat.

The assembly of this hanger is very simple, as it can be directly fastened to the ceiling through its top hole and a stud bolt can be directly fastened to the nut placed over the spring.

AMC-MECANOCAUCHO® VT HD Hangers, due to their low stiffness, are able to reach natural frequencies from 2 to 5Hz, and are specially suitable for applications where high isolation level is required.

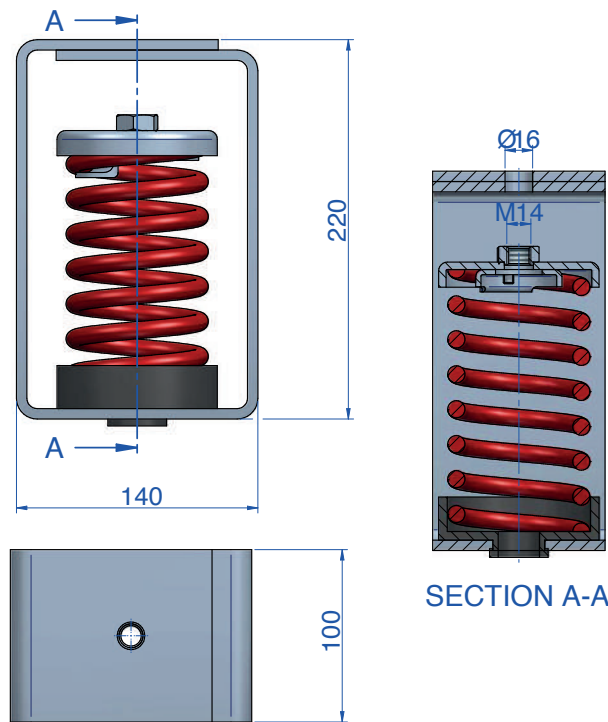

Type	MAX PERMANENT LOAD	Spring color	DEFLECTION mm	Code
VT-67 HD	67	BLUE	50	20235
VT-95 HD	95	WHITE	50	20239
VT-123 HD	123	BLACK	50	20236
VT-173 HD	173	BEIGE	50	20240
VT-223 HD	223	RED	50	20237
VT-335 HD	335	GREY	50	20241
VT-446 HD	446	GREEN	50	20238

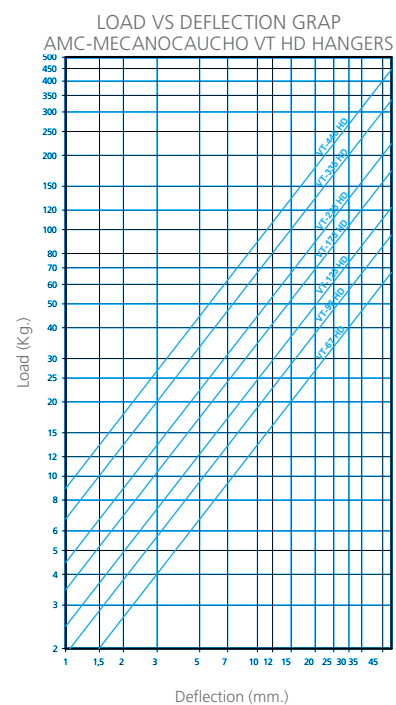
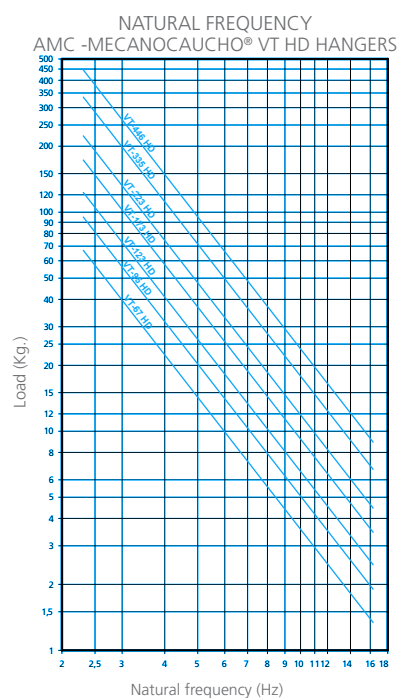

V-SH

The V-SH spring mounts are able to reach low natural frequencies from 2 to 5 Hz. The spring combined with sylomer® is able to provide high isolation at low and medium frequencies.

The curves are showing the deflection and natural frequencies according to the load of the spring.

This range of mounts comprises:

- A spring with high elasticity and very low natural frequency.
- An incorporated levelling system.
- A non-slip rubber base.
- A spare Sylomer to isolate mid and high frequencies comes standard.

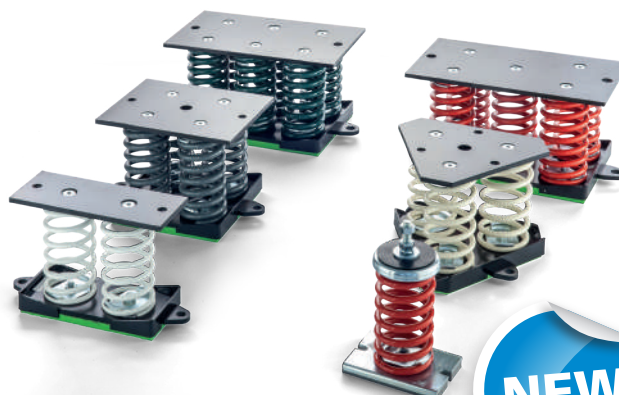

V-SH

Natural Frequency 2 to 5 Hz

Type	A (mm.)	B (mm.)	Spring color	C (mm.)	D (mm.)	E (mm.)	F (mm.)	Load (kg.)	Code	Weight (kg.)
V-SH 67	93	173	BLUE	M12	98,5	120	12	67	20397	1,48
V-SH 95	93	173	WHITE	M12	98,5	120	12	95	20465	1,53
V-SH 123	93	173	BLACK	M12	98,5	120	12	123	20398	1,56
V-SH 173	93	173	BEIGE	M12	98,5	120	12	173	20466	1,65
V-SH 223	93	173	RED	M12	98,5	120	12	223	20399	2,01
V-SH 335	93	173	GREY	M12	98,5	120	12	335	20467	2,32
V-SH 446	93	173	GREEN	M12	98,5	120	12	446	20400	2,52

Type	A (mm.)	B (mm.)	Spring color	D (mm.)	E (mm.)	F (mm.)	G (mm.)	H (mm.)	I (mm.)	J (mm.)	Load (kg.)	Code	Weight (kg.)
2V-SH 134	250	180	BLUE	100	14	210	100	106	270	298	134	20405	5,03
2V-SH 190	250	180	WHITE	100	14	210	100	106	270	298	190	21010	5,15
2V-SH 246	250	180	BLACK	100	14	210	100	106	270	298	226	20406	5,20
2V-SH 346	250	180	BEIGE	100	14	210	100	106	270	298	346	21011	5,38
2V-SH 446	250	180	RED	100	14	210	100	106	270	298	446	20407	6,12
2V-SH 670	250	180	GREY	100	14	210	100	106	270	298	670	21012	6,52
2V-SH 892	250	180	GREEN	100	14	210	100	106	270	298	892	20408	7,05

Type	A (mm.)	B (mm.)	Spring color	C (mm.)	D (mm.)	E (mm.)	F (mm.)	G (mm.)	H (mm.)	I (mm.)	Load (kg.)	Code	Weight (kg.)
3V-SH 201	219	180	BLUE	M20	14	246	136	251	220	255,7	201	21020	7,55
3V-SH 285	219	180	WHITE	M20	14	246	136	251	220	255,7	285	21021	7,72
3V-SH 369	219	180	BLACK	M20	14	246	136	251	220	255,7	369	21022	7,79
3V-SH 519	219	180	BEIGE	M20	14	246	136	251	220	255,7	519	21023	8,06
3V-SH 669	219	180	RED	M20	14	246	136	251	220	255,7	669	21024	9,17
3V-SH 1005	219	180	GREY	M20	14	246	136	251	220	255,7	1005	21025	9,77
3V-SH 1338	219	180	GREEN	M20	14	246	136	251	220	255,7	1338	21026	10,57

V-SH Natural Frequency 2 to 5 Hz

Type	A (mm.)	B (mm.)	Spring color	C (mm.)	D (mm.)	E (mm.)	F (mm.)	G (mm.)	H (mm.)	I (mm.)	Load (kg.)	Code	Weight (kg.)
4V-SH 268	250	180	BLUE	M20	200	14	210	260	288	206	268	21030	11,15
4V-SH 380	250	180	WHITE	M20	200	14	210	260	288	206	380	21031	11,95
4V-SH 492	250	180	BLACK	M20	200	14	210	260	288	206	492	21032	12,2
4V-SH 692	250	180	BEIGE	M20	200	14	210	260	288	206	692	21033	12,49
4V-SH 892	250	180	RED	M20	200	14	210	260	288	206	892	21034	12,72
4V-SH 1340	250	180	GREY	M20	200	14	210	260	288	206	1340	21035	13,14
4V-SH 1784	250	180	GREEN	M20	200	14	210	260	288	206	1784	21036	14,00

Type	A (mm.)	B (mm.)	Spring color	D (mm.)	E (mm.)	F (mm.)	G (mm.)	H (mm.)	I (mm.)	Load (kg.)	Code	Weight (kg.)
5V-SH 335	350	180	BLUE	200	18	315	360	396	206	335	21040	13,07
5V-SH 475	350	180	WHITE	200	18	315	360	396	206	475	21041	13,35
5V-SH 615	350	180	BLACK	200	18	315	360	396	206	615	21042	13,48
5V-SH 865	350	180	BEIGE	200	18	315	360	396	206	865	21043	13,92
5V-SH 1115	350	180	RED	200	18	315	360	396	206	1115	21044	15,78
5V-SH 1675	350	180	GREY	200	18	315	360	396	206	1675	21045	16,78
5V-SH 2230	350	180	GREEN	200	18	315	360	396	206	2230	21046	18,11

Type	A (mm.)	B (mm.)	Spring color	D (mm.)	E (mm.)	F (mm.)	G (mm.)	H (mm.)	I (mm.)	Load (kg.)	Code	Weight (kg.)
6V-SH 402	350	180	BLUE	200	18	300	360	396	206	402	21050	13,87
6V-SH 570	350	180	WHITE	200	18	300	360	396	206	570	21051	14,21
6V-SH 738	350	180	BLACK	200	18	300	360	396	206	738	21052	14,35
6V-SH 1038	350	180	BEIGE	200	18	300	360	396	206	1038	21053	14,89
6V-SH 1338	350	180	RED	200	18	300	360	396	206	1338	21054	17,12
6V-SH 2010	350	180	GREY	200	18	300	360	396	206	2010	21055	18,32
6V-SH 2676	350	180	GREEN	200	18	300	360	396	206	2676	21056	19,92

Type	A (mm.)	B (mm.)	Spring color	D (mm.)	E (mm.)	F (mm.)	G (mm.)	H (mm.)	I (mm.)	J (mm.)	Load (kg.)	Code	Weight (kg.)
9V-SH 603	350	180	BLUE	300	18	310	360	396	306	100	603	21060	21,17
9V-SH 855	350	180	WHITE	300	18	310	360	396	306	100	855	21061	21,68
9V-SH 1107	350	180	BLACK	300	18	310	360	396	306	100	1107	21062	21,90
9V-SH 1557	350	180	BEIGE	300	18	310	360	396	306	100	1557	21063	22,71
9V-SH 2007	350	180	RED	300	18	310	360	396	306	100	2007	21064	26,05
9V-SH 3015	350	180	GREY	300	18	310	360	396	306	100	3015	21065	27,86
9V-SH 4014	350	180	GREEN	300	18	310	360	396	306	100	4014	21066	30,25

V-SH ELASTICAL PROPERTIES

LOAD VS DEFLECTION DIAGRAM
AMC-MECANOCAUCHO® 1V-SH

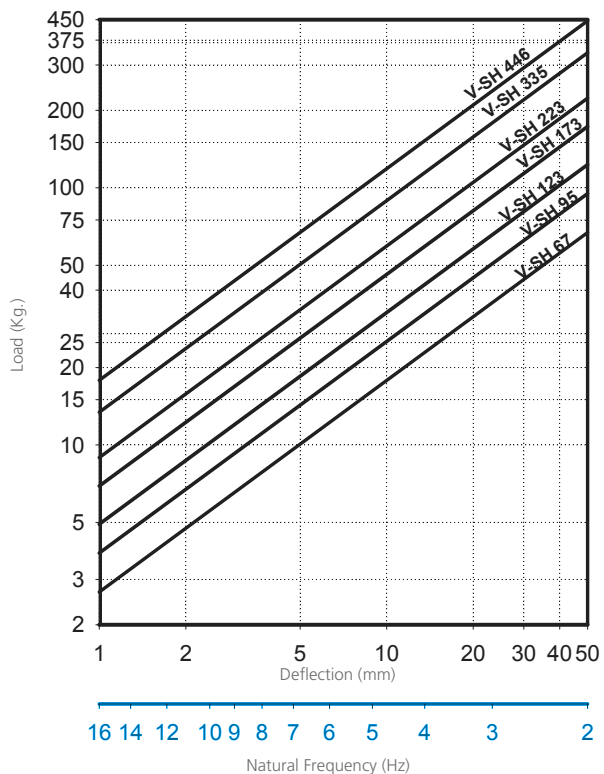

LOAD VS DEFLECTION DIAGRAM
AMC-MECANOCAUCHO® 2V-SH

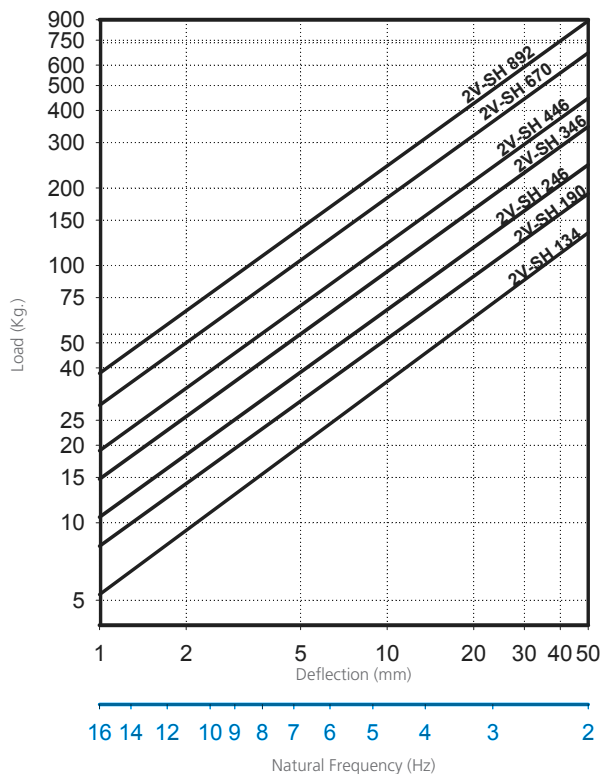

LOAD VS DEFLECTION DIAGRAM
AMC-MECANOCAUCHO® 3V-SH

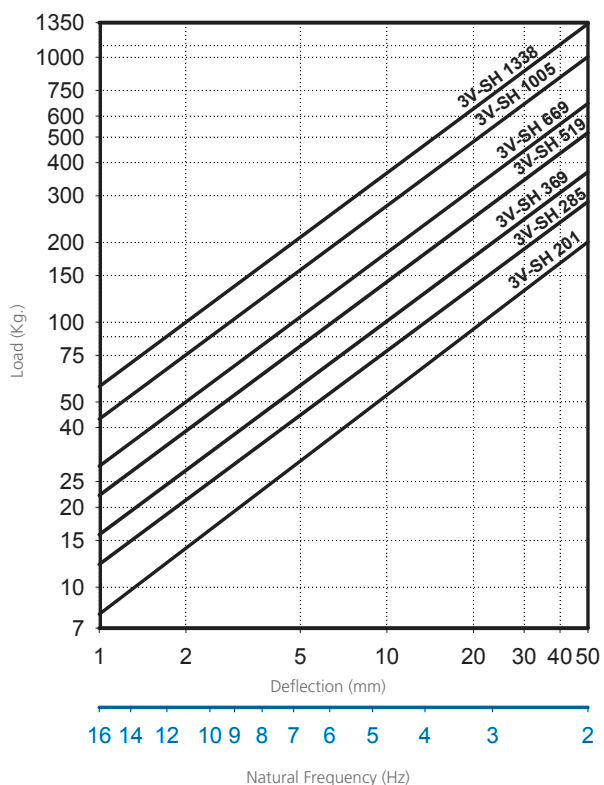

LOAD VS DEFLECTION DIAGRAM
AMC-MECANOCAUCHO® 4V-SH

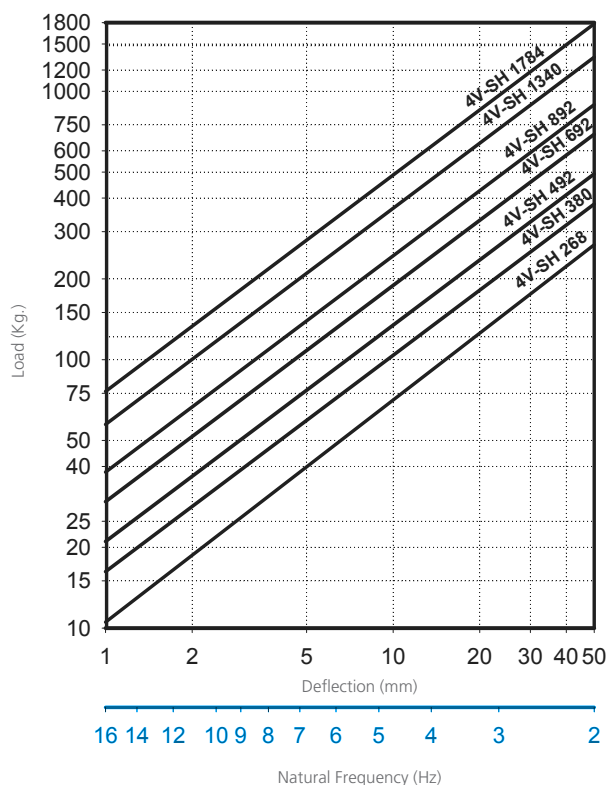

V-SH ELASTICAL PROPERTIES

LOAD VS DEFLECTION DIAGRAM
AMC-MECANOCAUCHO® 5V-SH

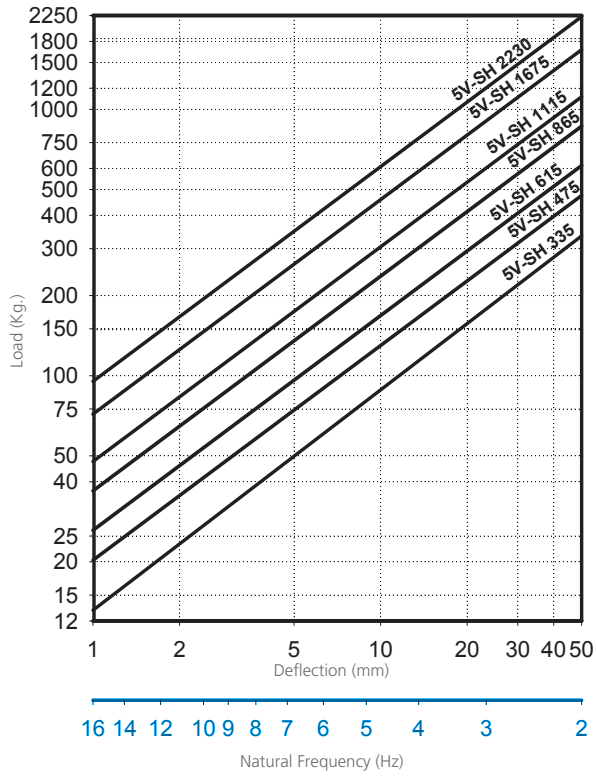

LOAD VS DEFLECTION DIAGRAM
AMC-MECANOCAUCHO® 6V-SH

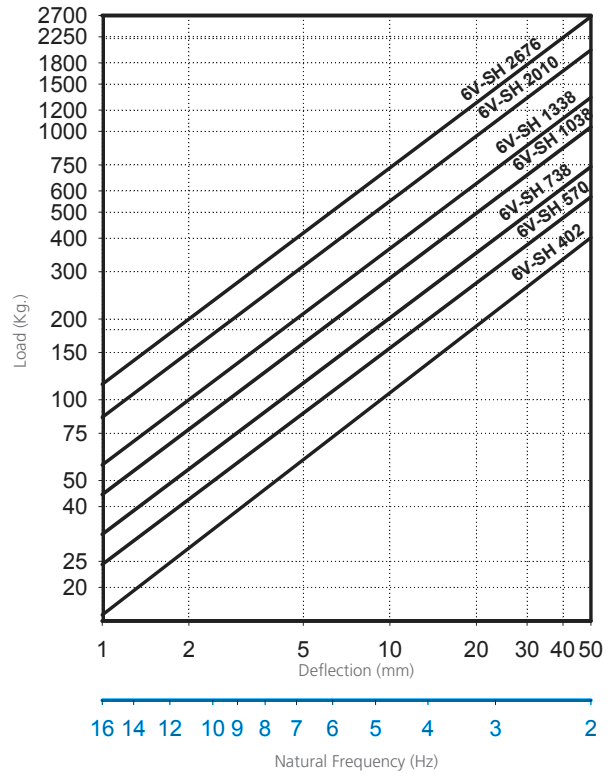

LOAD VS DEFLECTION DIAGRAM
AMC-MECANOCAUCHO® 9V-SH

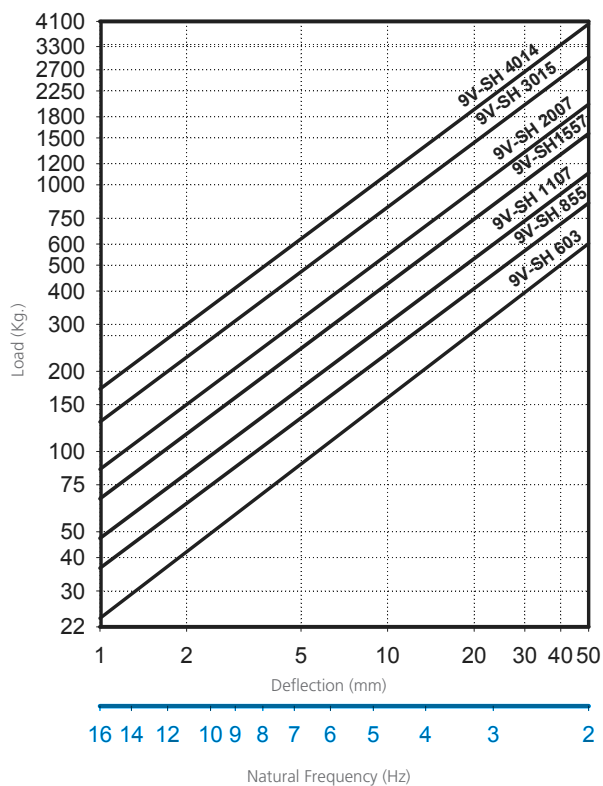

V-SR

The V-SR spring mounts are able to reach low natural frequencies from 3 to 5 Hz. The spring combined with sylomer® is able to provide high isolation at low and medium frequencies.

The curves are showing the deflection and natural frequencies according to the load of the spring.

This range of mounts comprises:

- A spring with high elasticity and very low natural frequency.
- An incorporated levelling system.
- A non-slip rubber base.
- A spare Sylomer to isolate mid and high frequencies comes standard.



V-SR Natural Frequency 3 to 5 Hz

Type	A (mm.)	B (mm.)	Spring color	C (mm.)	D (mm.)	E (mm.)	F (mm.)	Load (kg.)	Code	Weight (kg.)
V-SR-250	75	129	BLACK	M10	100	120	12	250	20391	1,5
V-SR-350	75	129	BEIGE	M10	100	120	12	350	20392	1,7
V-SR-650	93	172	BLACK	M12	100	120	12	650	20393	2,3
V-SR-800	93	172	BLACK	M12	100	120	12	800	20394	2,6
V-SR-1000	93	172	BLACK	M12	100	120	12	1000	20395	3
V-SR-1200	93	172	BLACK	M12	100	120	12	1200	20396	3,2

Type	A (mm.)	B (mm.)	Spring color	D (mm.)	E (mm.)	F (mm.)	G (mm.)	H (mm.)	I (mm.)	J (mm.)	Load (kg.)	Code	Weight (kg.)
2V-SR-1300	250	180	BLACK	100	14	210	100	106	270	298	1300	21071	7,32
2V-SR-1600	250	180	BLACK	100	14	210	100	106	270	298	1600	21072	7,46
2V-SR-2000	250	180	BLACK	100	14	210	100	106	270	298	2000	21073	7,78
2V-SR-2400	250	180	BLACK	100	14	210	100	106	270	298	2400	21074	7,98

Type	A (mm.)	B (mm.)	Spring color	C (mm.)	D (mm.)	E (mm.)	F (mm.)	G (mm.)	H (mm.)	I (mm.)	Load (kg.)	Code	Weight (kg.)
3V-SR-1950	219	180	BLACK	M20	14	246	136	251	220	255,7	1950	21131	10,49
3V-SR-2400	219	180	BLACK	M20	14	246	136	251	220	255,7	2400	21132	10,56
3V-SR-3000	219	180	BLACK	M20	14	246	136	251	220	255,7	3000	21133	11,48
3V-SR-3600	219	180	BLACK	M20	14	246	136	251	220	255,7	3600	21134	11,70

V-SR
Natural Frequency 3 to 5 Hz

Type	A (mm.)	B (mm.)	Spring color	C (mm.)	D (mm.)	E (mm.)	F (mm.)	G (mm.)	H (mm.)	I (mm.)	Load (kg.)	Code	Weight (kg.)
4V-SR-2600	250	180	BLACK	M20	200	14	210	260	288	206	2600	21081	13,12
4V-SR-3200	250	180	BLACK	M20	200	14	210	260	288	206	3200	21082	13,46
4V-SR-4000	250	180	BLACK	M20	200	14	210	260	288	206	4000	21083	13,78
4V-SR-4800	250	180	BLACK	M20	200	14	210	260	288	206	4800	21084	13,88

Type	A (mm.)	B (mm.)	Spring color	D (mm.)	E (mm.)	F (mm.)	G (mm.)	H (mm.)	I (mm.)	Load (kg.)	Code	Weight (kg.)
5V-SR-3250	350	180	BLACK	200	18	315	360	396	206	3250	21091	17,97
5V-SR-4000	350	180	BLACK	200	18	315	360	396	206	4000	21092	18,09
5V-SR-5000	350	180	BLACK	200	18	315	360	396	206	5000	21093	19,62
5V-SR-6000	350	180	BLACK	200	18	315	360	396	206	6000	21094	19,99

Type	A (mm.)	B (mm.)	Spring color	D (mm.)	E (mm.)	F (mm.)	G (mm.)	H (mm.)	I (mm.)	Load (kg.)	Code	Weight (kg.)
6V-SR-3900	350	180	BLACK	200	18	300	360	396	206	3900	21101	19,75
6V-SR-4800	350	180	BLACK	200	18	300	360	396	206	4800	21102	19,90
6V-SR-6000	350	180	BLACK	200	18	300	360	396	206	6000	21103	21,73
6V-SR-7200	350	180	BLACK	200	18	300	360	396	206	7200	21104	22,17

Type	A (mm.)	B (mm.)	Spring color	D (mm.)	E (mm.)	F (mm.)	G (mm.)	H (mm.)	I (mm.)	J (mm.)	Load (kg.)	Code	Weight (kg.)
9V-SR-5850	350	180	BLACK	300	18	310	360	396	306	100	5850	21111	29,99
9V-SR-7200	350	180	BLACK	300	18	310	360	396	306	100	7200	21112	30,22
9V-SR-9000	350	180	BLACK	300	18	310	360	396	306	100	9000	21113	32,96
9V-SR-10800	350	180	BLACK	300	18	310	360	396	306	100	10800	21114	33,63

V-SR ELASTICAL PROPERTIES

LOAD VS DEFLECTION DIAGRAM
AMC-MECANOCAUCHO® 1V-SR

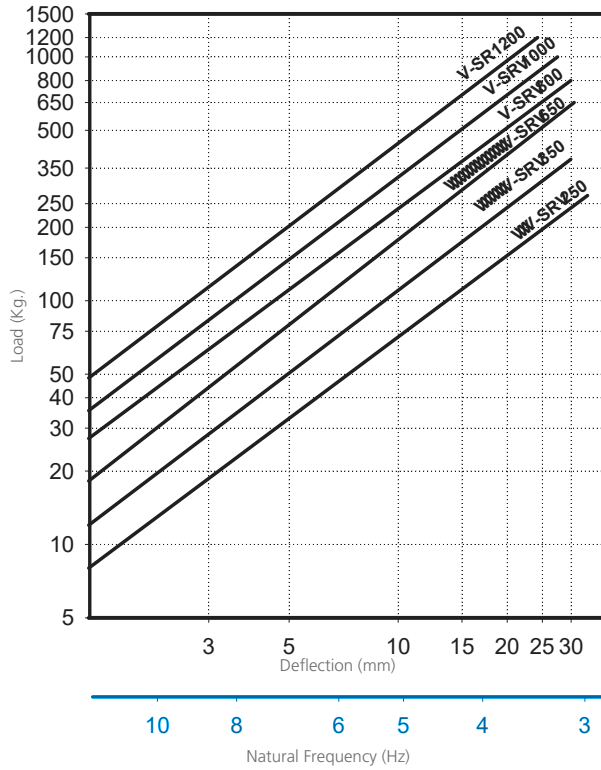

LOAD VS DEFLECTION DIAGRAM
AMC-MECANOCAUCHO® 2V-SR

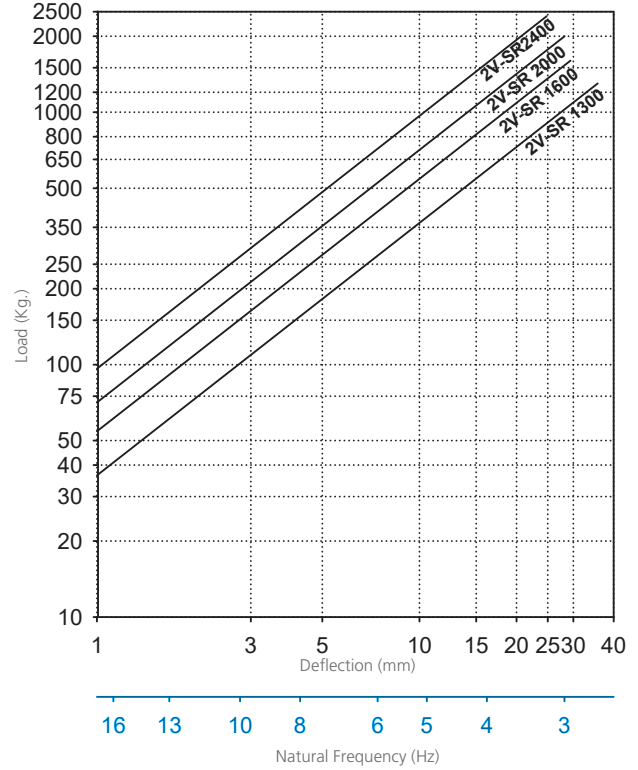

LOAD VS DEFLECTION DIAGRAM
AMC-MECANOCAUCHO® 3V-SR

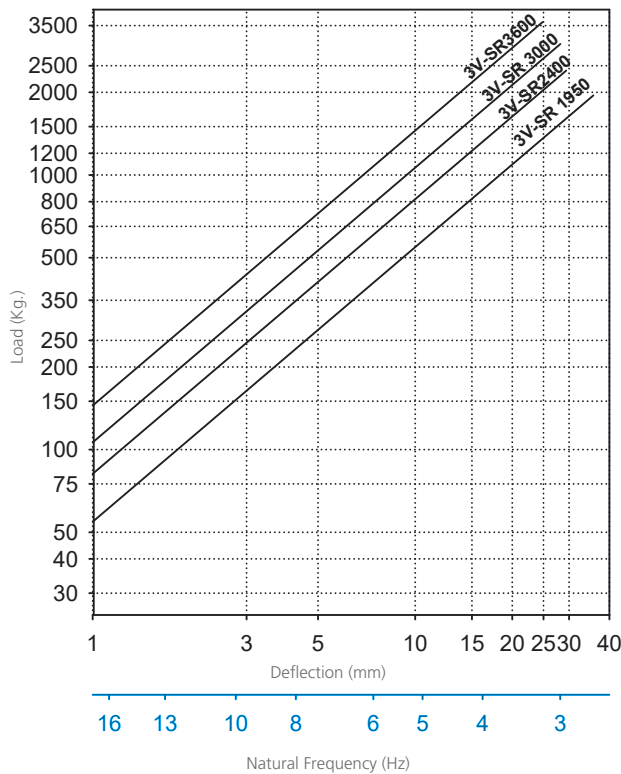

LOAD VS DEFLECTION DIAGRAM
AMC-MECANOCAUCHO® 4V-SR

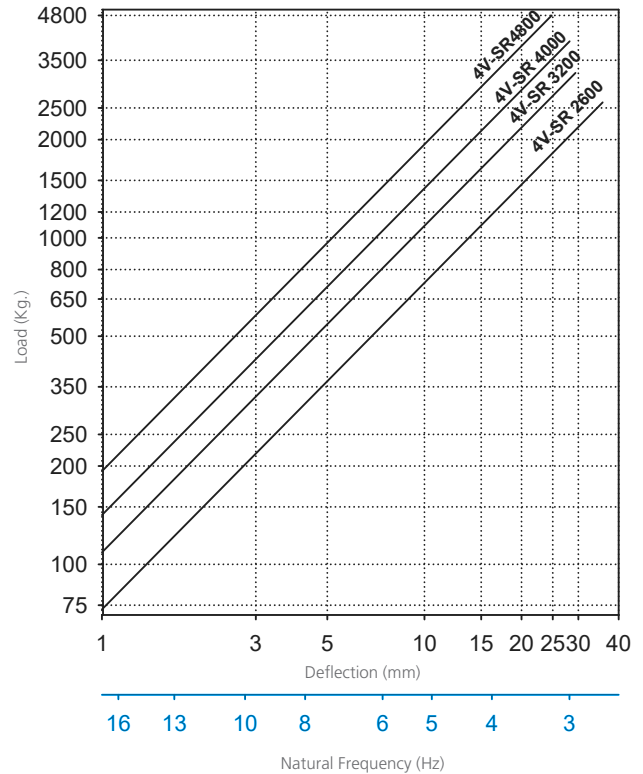

V-SR ELASTICAL PROPERTIES

LOAD VS DEFLECTION DIAGRAM
AMC-MECANOCAUCHO® 5V-SR

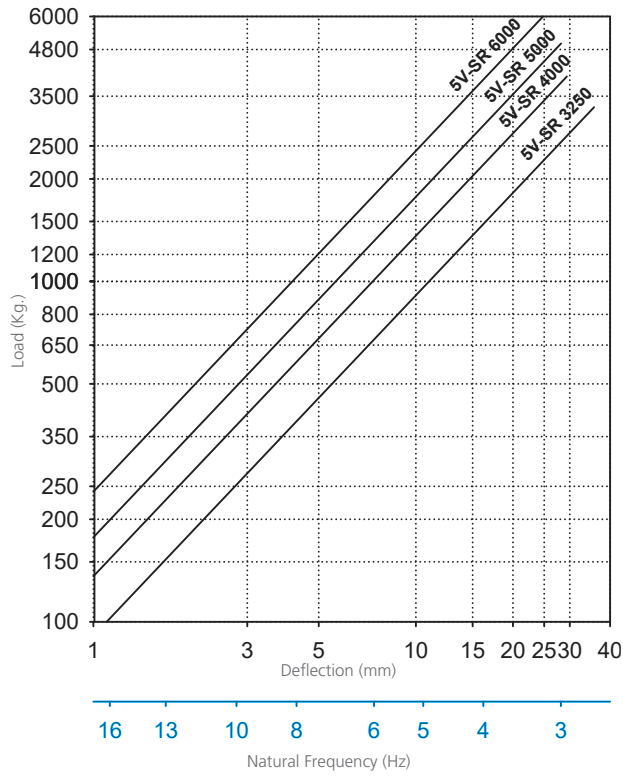

LOAD VS DEFLECTION DIAGRAM
AMC-MECANOCAUCHO® 6V-SR

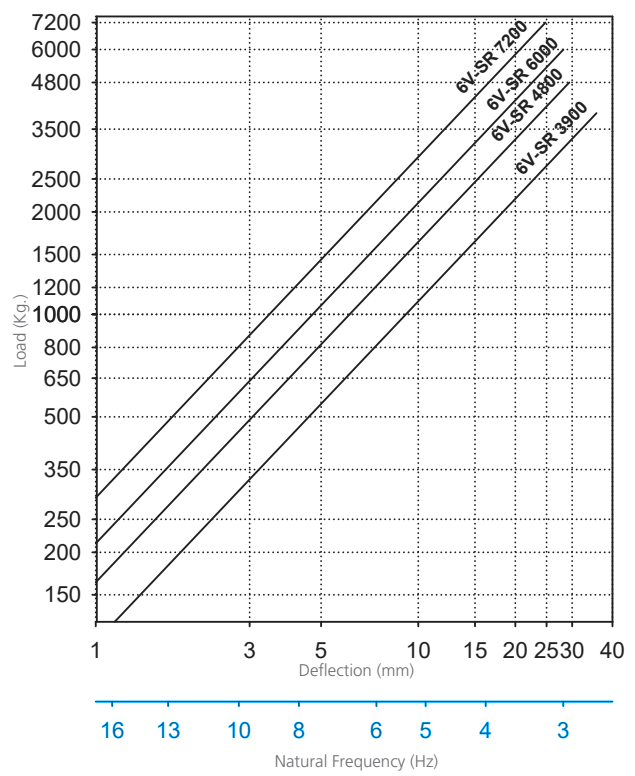

LOAD VS DEFLECTION DIAGRAM
AMC-MECANOCAUCHO® 9V-SR

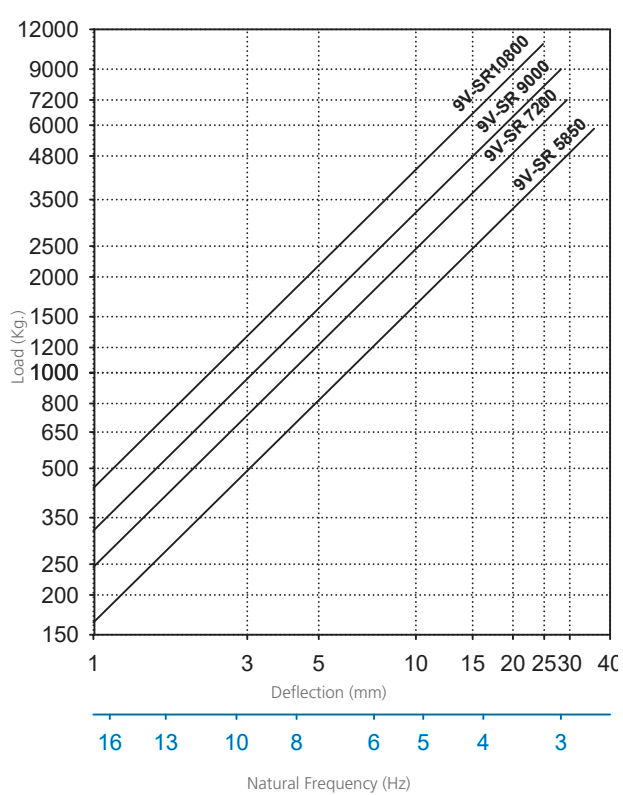

AMC Anti-seismic supports

These spring mounts incorporate an ANTISEISMIC device to protect the spring from earthquakes.

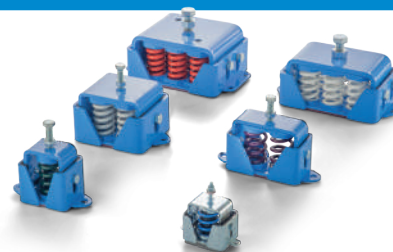

Natural frequency: 3,5-5 Hz

	Type	Spring color	LOAD kg MAX	Code
	ANTI-SEISMIC MINI	BLACK	25	21271
		BLUE	50	21272
		GREY	75	21273
		BEIGE	100	21274
		WHITE	125	21275
		BLACK	150	21276
	ANTI-SEISMIC MINI + SYLOMER®	RED	250	21277
		BLACK	25	21261
		BLUE	50	21262
		GREY	75	21263
		BEIGE	100	21264
		WHITE	125	21265
BLACK	150	21266		
RED	250	21267		

	Type	No. Springs	Spring color	DEFLEC-TION mm	Weight (kg)	LOAD kg MAX	Code
	1 AMC ANTI-SEISMIC	1	PURPLE	22	3,155	305	20409
		1	GREEN	22	3,204	405	20381
		1	GREY	22	3,318	540	20382
		1	WHITE	22	3,248	612	20383
		1	RED	22	3,414	803	20384
	1 AMC ANTI-SEISMIC + SYLOMER®	1	PURPLE	22	3,191	305	20413
		1	GREEN	22	3,686	405	20377
		1	GREY	22	3,284	540	20378
		1	WHITE	22	3,284	612	20379
		1	RED	22	3,449	803	20380
	2 AMC ANTI-SEISMIC	2	PURPLE	22	4,819	610	20494
		2	GREEN	22	4,919	810	20496
		2	GREY	22	5,011	1080	20497
		2	WHITE	22	5,142	1224	20498
		2	RED	22	5,337	1606	20500
	2 AMC ANTI-SEISMIC + SYLOMER®	2	PURPLE	22	4,869	610	20480
		2	GREEN	22	4,97	810	20487
		2	GREY	22	5,192	1080	20488
		2	WHITE	22	5,06	1224	20489
		2	RED	22	5,386	1606	20490
	4 AMC ANTI-SEISMIC	4	PURPLE	22	10,594	1220	20700
		4	GREEN	22	10,894	1620	20696
		4	GREY	22	11,346	2160	20697
		4	WHITE	22	11,002	2448	20698
		4	RED	22	11,69	3212	20699
	4 AMC ANTI-SEISMIC + SYLOMER®	4	PURPLE	22	10,54	1220	20686
		4	GREEN	22	10,84	1620	20687
		4	GREY	22	11,292	2160	20688
		4	WHITE	22	10,948	2448	20689
		4	RED	22	11,636	3212	20690

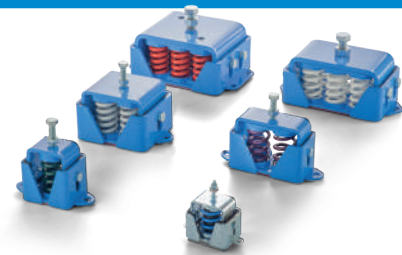

	Type	No. Springs	Spring color	DEFLECTION mm	Weight (kg)	LOAD kg MAX	Code
	6 AMC ANTI-SEISMIC	6	PURPLE	22	14,909	1830	20761
		6	GREEN	22	15,359	2430	20762
		6	GREY	22	16,037	3240	20763
		6	WHITE	22	15,521	3672	20764
		6	RED	22	16,553	4818	20765
	6 AMC ANTI-SEISMIC + SYLOMER®	6	PURPLE	22	14,829	1830	20766
		6	GREEN	22	15,279	2430	20767
		6	GREY	22	15,957	3240	20768
		6	WHITE	22	15,441	3672	20769
		6	RED	22	16,473	4818	20770
	9 AMC ANTI-SEISMIC	9	PURPLE	22	21,598	2745	20961
		9	GREEN	22	22,273	3645	20962
		9	GREY	22	23,29	4860	20963
		9	WHITE	22	22,516	5508	20964
		9	RED	22	24,064	7227	20965
	9 AMC ANTI-SEISMIC + SYLOMER®	9	PURPLE	22	21,483	2745	20992
		9	GREEN	22	22,158	3645	20993
		9	GREY	22	23,175	4860	20994
		9	WHITE	22	22,401	5508	20995
		9	RED	22	23,949	7227	20996
	10 AMC ANTI-SEISMIC	10	PURPLE	22	24,9	3050	20894
		10	GREEN	22	24,9	4050	20895
		10	GREY	22	24,9	5400	20896
		10	WHITE	22	24,9	6120	20897
		10	RED	22	24,9	8030	20898
	10 AMC ANTI-SEISMIC + SYLOMER®	10	PURPLE	22	24,9	3050	20852
		10	GREEN	22	24,9	4050	20853
		10	GREY	22	24,9	5400	20854
		10	WHITE	22	24,9	6120	20855
		10	RED	22	24,9	8030	20856

NEW

NEW

	Type	SUMMARY	Weight (kg)	Code
	SNUBBER 4 ANTI-SEISMIC	Dimensions A, B, C and D could vary according to the selected mount and the characteristics of the frame	-	22000

ANTISEISMIC ELASTICAL PROPERTIES

LOAD VS DEFLECTION DIAGRAM
AMC-MECANOCAUCHO® Antiseismic mini

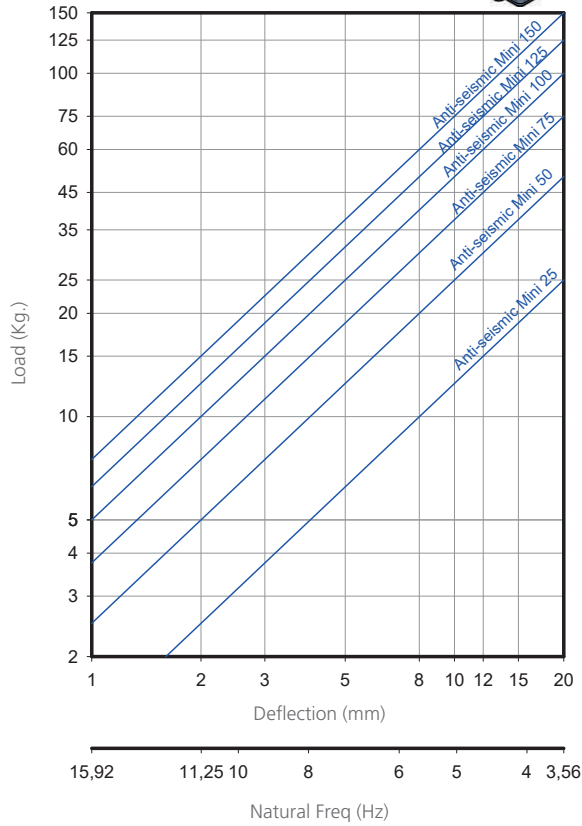

LOAD VS DEFLECTION DIAGRAM
AMC-MECANOCAUCHO® 1 AMC Antiseismic mount

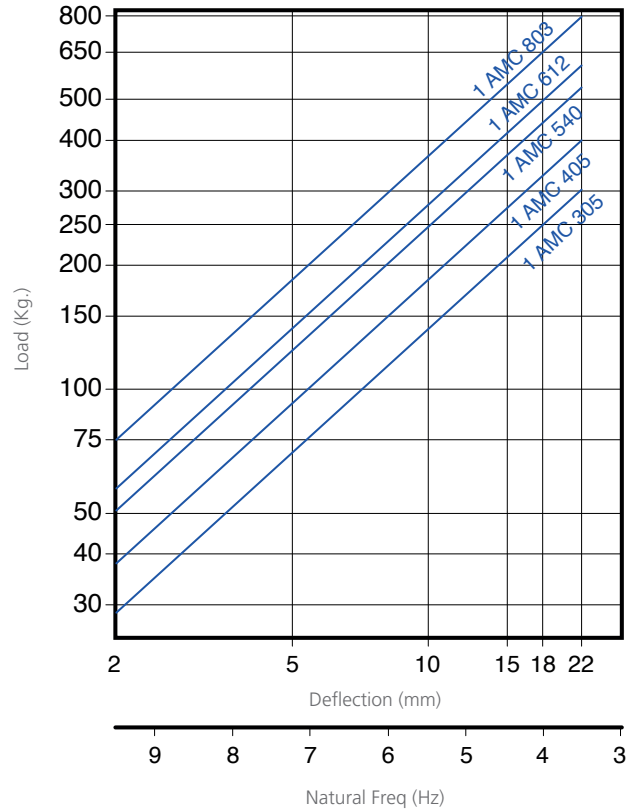

LOAD VS DEFLECTION DIAGRAM
AMC-MECANOCAUCHO® 2 AMC Antiseismic mount

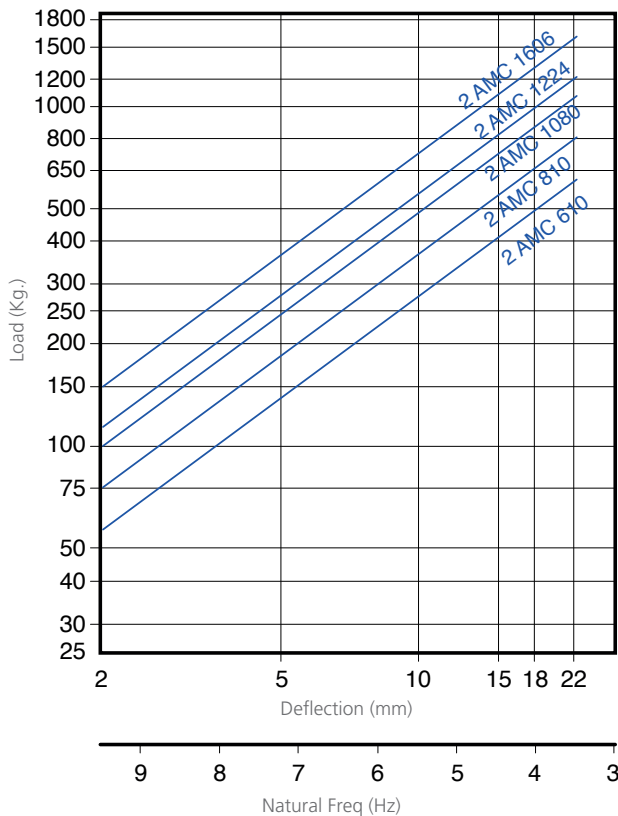
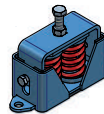

LOAD VS DEFLECTION DIAGRAM
AMC-MECANOCAUCHO® 4 AMC Antiseismic mount

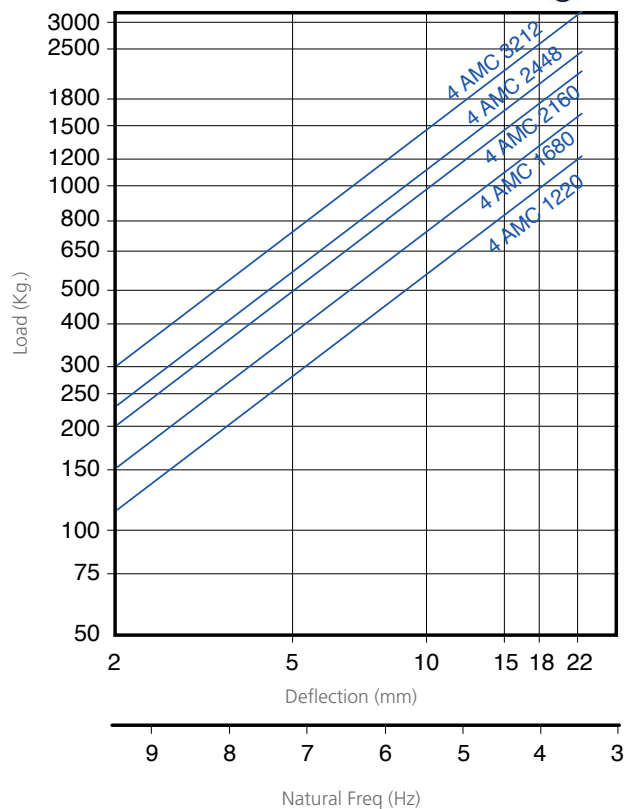
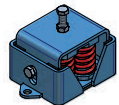

LOAD VS DEFLECTION DIAGRAM
AMC-MECANOCAUCHO® 6 AMC Antiseismic mount

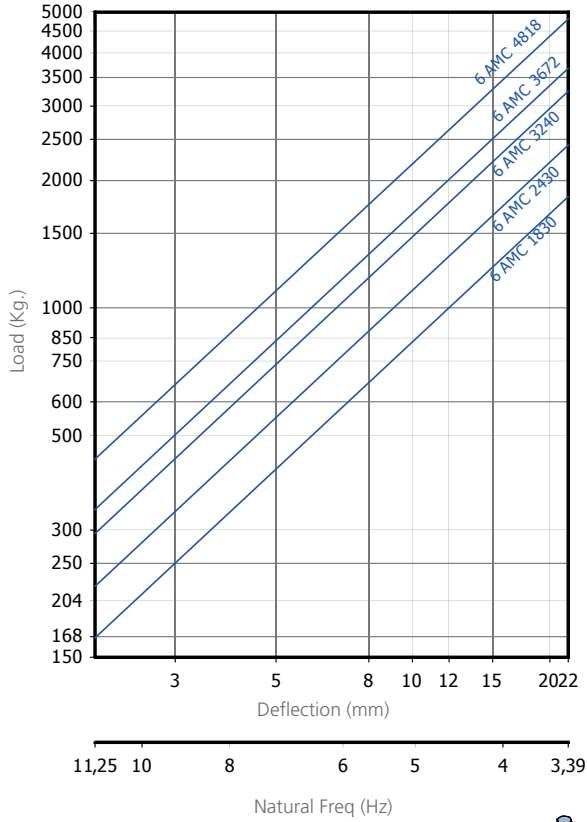
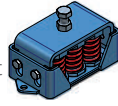

LOAD VS DEFLECTION DIAGRAM
AMC-MECANOCAUCHO® 9 AMC Antiseismic mount

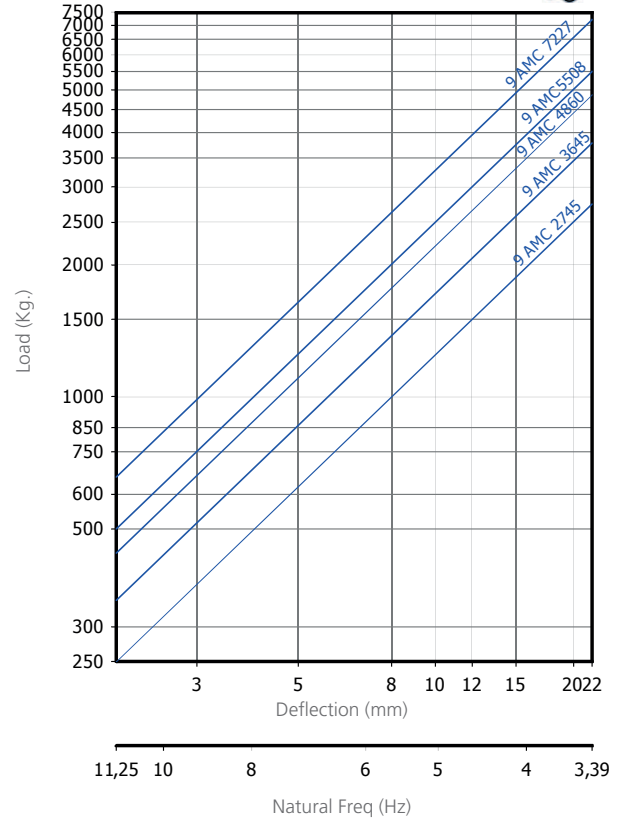
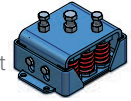

LOAD VS DEFLECTION DIAGRAM
AMC-MECANOCAUCHO® 10 AMC Antiseismic mount

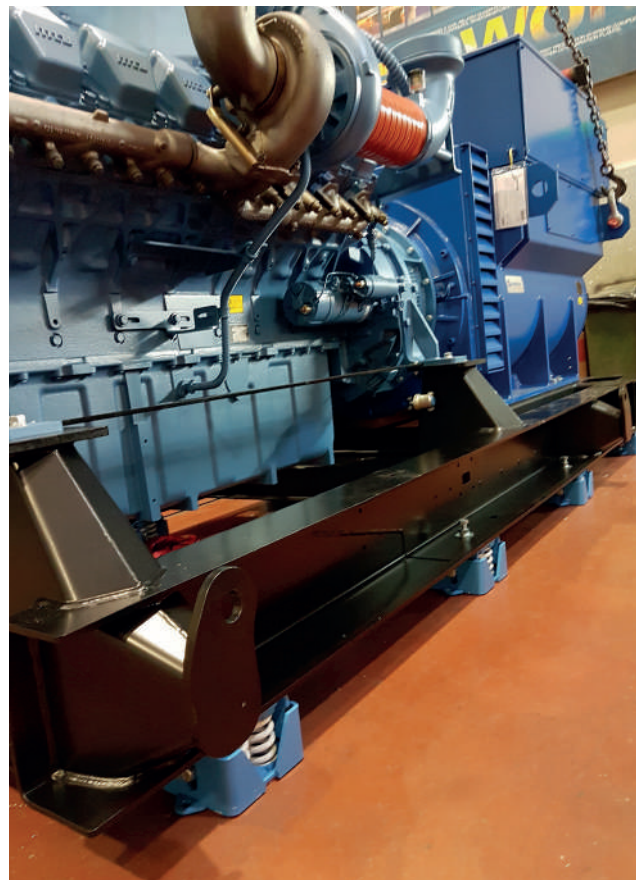
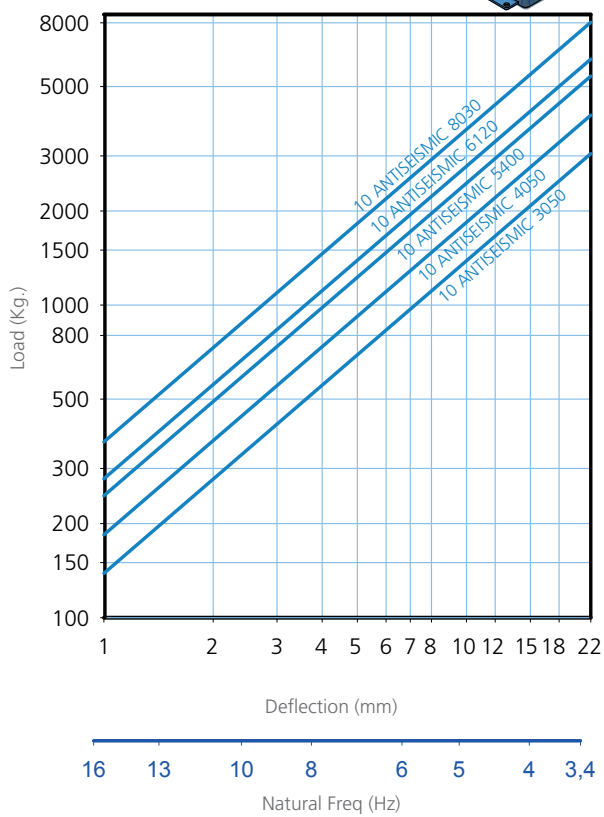
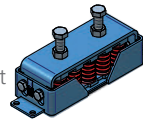

VSH anti-seismic supports

This range of mounts comprises:

- A spring with high elasticity and very low natural frequency
- An incorporated levelling system
- A spare Sylomer to isolate mid and high frequencies comes standard



Natural frequency: 2-5 Hz

	Type	Spring color	Load (kg)	Weight (kg)	Code
	1V-SH-67 ANTI SEISMIC + SYLOMER®	BLUE	67	5,554	20653
	1V-SH-95 ANTI SEISMIC + SYLOMER®	WHITE	95	5,554	20654
	1V-SH-123 ANTI SEISMIC + SYLOMER®	BLACK	123	5,554	20655
	1V-SH-173 ANTI SEISMIC + SYLOMER®	BEIGE	173	5,554	20656
	1V-SH-223 ANTI SEISMIC + SYLOMER®	RED	223	5,554	20657
	1V-SH-335 ANTI SEISMIC + SYLOMER®	GREY	335	5,554	20658
	1V-SH-446 ANTI SEISMIC + SYLOMER®	GREEN	446	5,554	20659
	2V-SH-134 ANTI SEISMIC + SYLOMER®	BLUE	134	10,561	20587
	2V-SH-190 ANTI SEISMIC + SYLOMER®	WHITE	190	10,561	20588
	2V-SH-246 ANTI SEISMIC + SYLOMER®	BLACK	246	10,561	20589
	2V-SH-346 ANTI SEISMIC + SYLOMER®	BEIGE	346	10,561	20590
	2V-SH-446 ANTI SEISMIC + SYLOMER®	RED	446	10,561	20591
	2V-SH-670 ANTI SEISMIC + SYLOMER®	GREY	670	10,561	20592
	2V-SH-892 ANTI SEISMIC + SYLOMER®	GREEN	892	10,561	20593
	4V-SH-268 ANTI SEISMIC + SYLOMER®	BLUE	268	20,883	20752
	4V-SH-380 ANTI SEISMIC + SYLOMER®	WHITE	380	20,883	20753
	4V-SH-492 ANTI SEISMIC + SYLOMER®	BLACK	492	20,883	20754
	4V-SH-692 ANTI SEISMIC + SYLOMER®	BEIGE	692	20,883	20755
	4V-SH-892 ANTI SEISMIC + SYLOMER®	RED	892	20,883	20756
	4V-SH-1340 ANTI SEISMIC + SYLOMER®	GREY	1340	20,883	20757
	4V-SH-1784 ANTI SEISMIC + SYLOMER®	GREEN	1784	20,883	20758
	6V-SH-402 ANTI SEISMIC + SYLOMER®	BLUE	402	30,579	20861
	6V-SH-570 ANTI SEISMIC + SYLOMER®	WHITE	570	30,579	20862
	6V-SH-738 ANTI SEISMIC + SYLOMER®	BLACK	738	30,579	20863
	6V-SH-1038 ANTI SEISMIC + SYLOMER®	BEIGE	1038	30,579	20864
	6V-SH-1338 ANTI SEISMIC + SYLOMER®	RED	1338	30,579	20865
	6V-SH-2010 ANTI SEISMIC + SYLOMER®	GREY	2010	30,579	20866
	6V-SH-2676 ANTI SEISMIC + SYLOMER®	GREEN	2676	30,579	20867
	9V-SH-603 ANTI SEISMIC + SYLOMER®	BLUE	603	51,124	20887
	9V-SH-855 ANTI SEISMIC + SYLOMER®	WHITE	855	51,124	20888
	9V-SH-1107 ANTI SEISMIC + SYLOMER®	BLACK	1107	51,124	20889
	9V-SH-1557 ANTI SEISMIC + SYLOMER®	BEIGE	1557	51,124	20890
	9V-SH-2007 ANTI SEISMIC + SYLOMER®	RED	2007	51,124	20891
	9V-SH-3015 ANTI SEISMIC + SYLOMER®	GREY	3015	51,124	20892
9V-SH-4014 ANTI SEISMIC + SYLOMER®	GREEN	4014	51,124	20893	

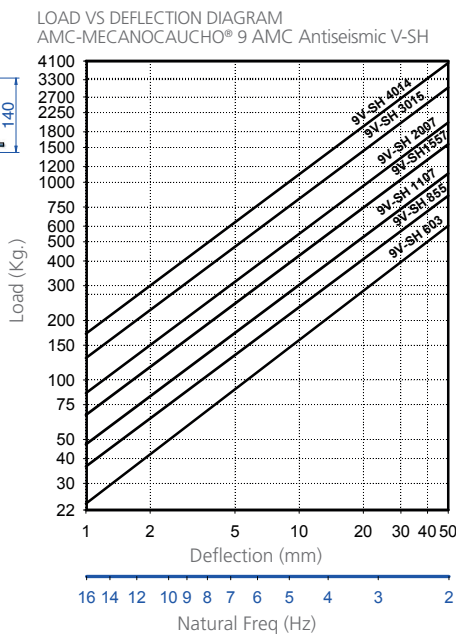
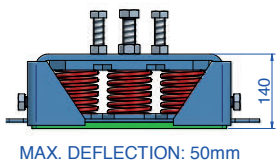
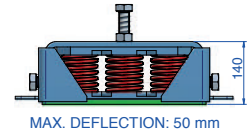
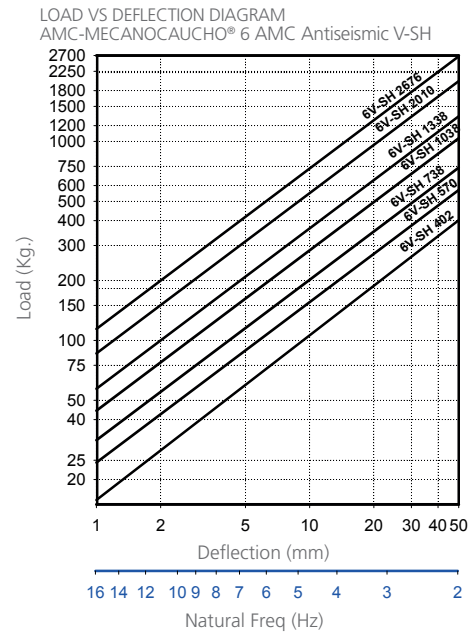
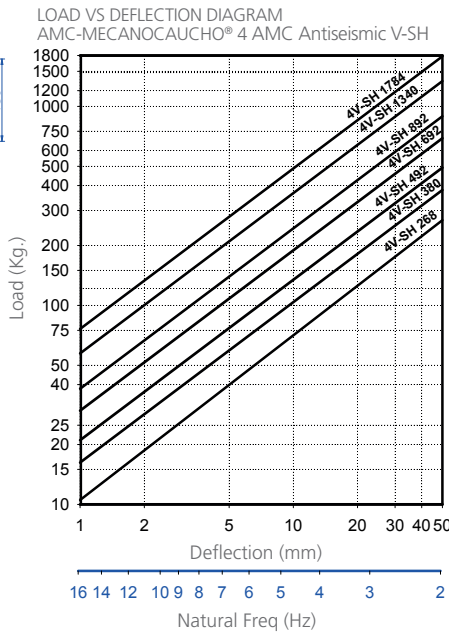
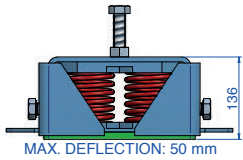
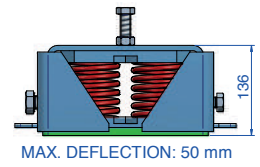
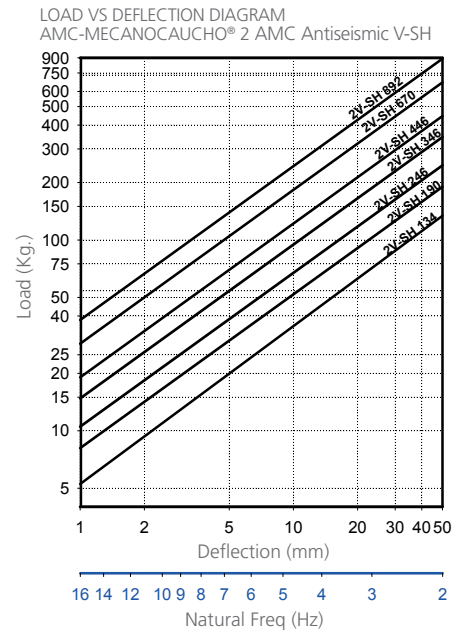
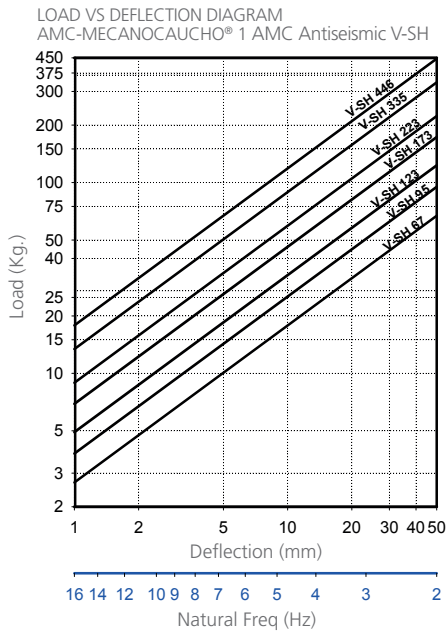
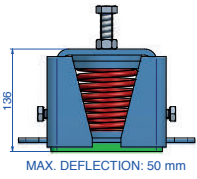

VSR anti-seismic supports

This range of mounts comprises:

- A spring high elasticity and very low natural frequency
- An incorporated levelling system
- A spare Sylomer to isolate mid and high frequencies comes standard



Natural frequency: 3-5 Hz

	Type	Spring color	Load (kg)	Weight (kg)	Code
	V-SR-650 ANTI SEISMIC + SYLOMER®	BLACK	650	6,5	20502
	V-SR-800 ANTI SEISMIC + SYLOMER®	BLACK	800	6,5	20503
	V-SR-1000 ANTI SEISMIC + SYLOMER®	BLACK	1000	6,5	20504
	V-SR-1200 ANTI SEISMIC + SYLOMER®	BLACK	1200	6,5	20505
	2V-SR-1300 ANTI SEISMIC + SYLOMER®	BLACK	1300	12,01	20506
	2V-SR-1600 ANTI SEISMIC + SYLOMER®	BLACK	1600	12,01	20507
	2V-SR-2000 ANTI SEISMIC + SYLOMER®	BLACK	2000	12,01	20508
	2V-SR-2400 ANTI SEISMIC + SYLOMER®	BLACK	2400	12,01	20509
	4V-SR-2600 ANTI SEISMIC + SYLOMER®	BLACK	2600	23,766	21141
	4V-SR-3200 ANTI SEISMIC + SYLOMER®	BLACK	3200	23,766	21142
	4V-SR-4000 ANTI SEISMIC + SYLOMER®	BLACK	4000	23,766	21143
	4V-SR-4800 ANTI SEISMIC + SYLOMER®	BLACK	4800	23,766	21144
	6V-SR-3900 ANTI SEISMIC + SYLOMER®	BLACK	3900	34,831	20877
	6V-SR-4800 ANTI SEISMIC + SYLOMER®	BLACK	4800	34,831	20878
	6V-SR-6000 ANTI SEISMIC + SYLOMER®	BLACK	6000	34,831	20879
	6V-SR-7200 ANTI SEISMIC + SYLOMER®	BLACK	7200	34,831	20880
	9V-SR-5850 ANTI SEISMIC + SYLOMER®	BLACK	5850	51,124	20952
	9V-SR-7200 ANTI SEISMIC + SYLOMER®	BLACK	7200	51,124	20953
	9V-SR-9000 ANTI SEISMIC + SYLOMER®	BLACK	9000	51,124	20954
	9V-SR-10800 ANTI SEISMIC + SYLOMER®	BLACK	10800	51,124	20955

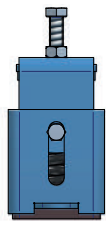

LOAD VS DEFLECTION DIAGRAM
AMC-MECANOCAUCHO® 1 AMC Antiseismic V-SR

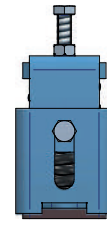
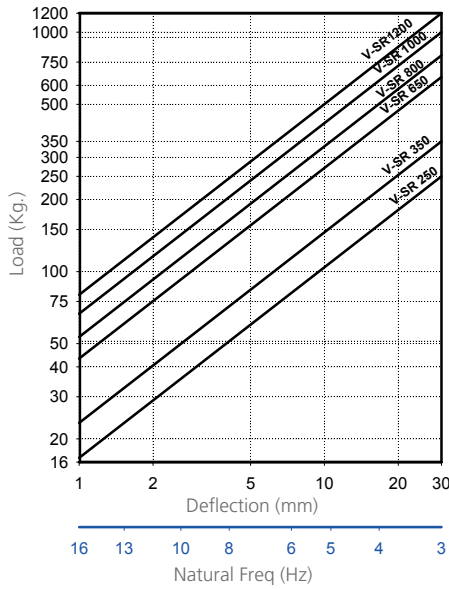

LOAD VS DEFLECTION DIAGRAM
AMC-MECANOCAUCHO® 2 AMC Antiseismic V-SR

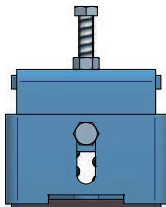
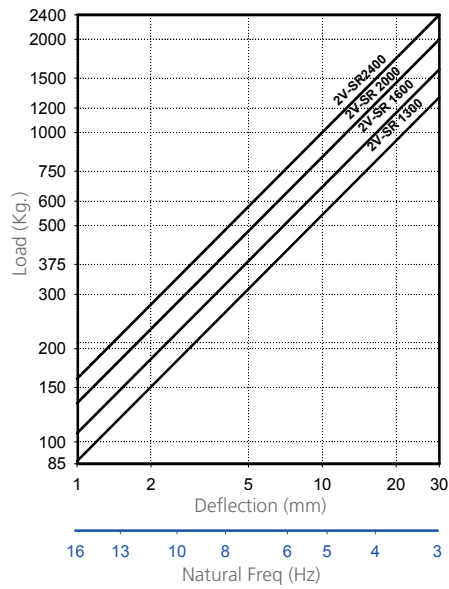

LOAD VS DEFLECTION DIAGRAM
AMC-MECANOCAUCHO® 4 AMC Antiseismic V-SR

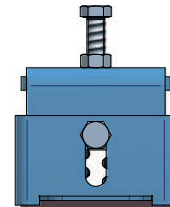
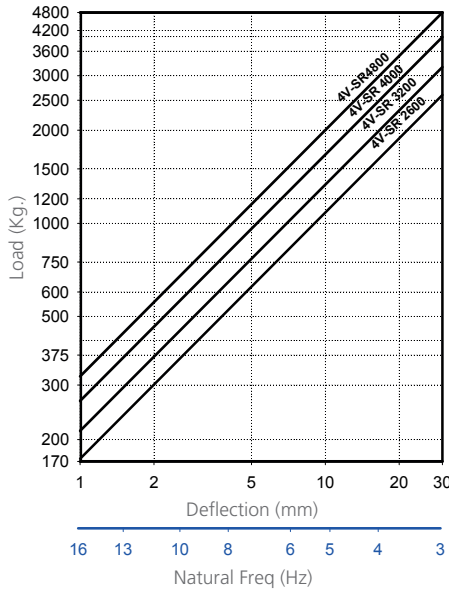

LOAD VS DEFLECTION DIAGRAM
AMC-MECANOCAUCHO® 6 AMC Antiseismic V-SR

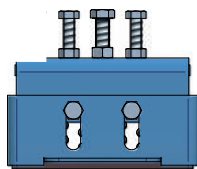
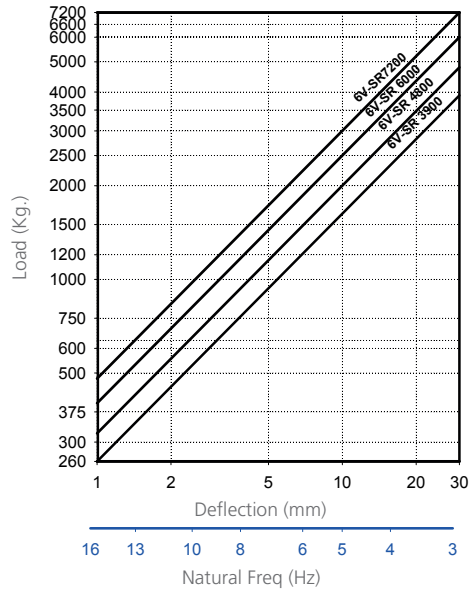

LOAD VS DEFLECTION DIAGRAM
AMC-MECANOCAUCHO® 9 AMC Antiseismic V-SR

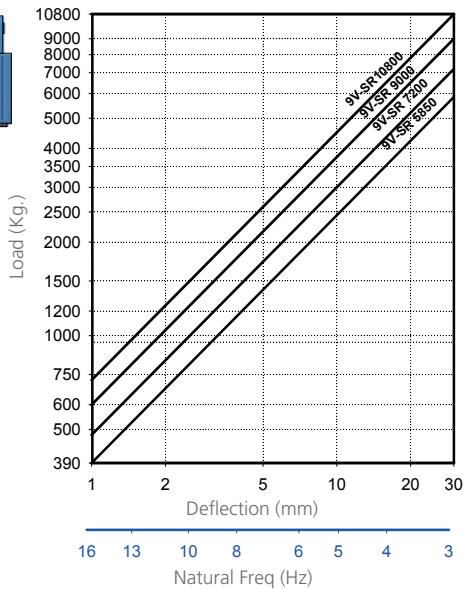

ANTI SEISMIC VISCO

This spring mount is suitable for those applications that require greater vibration isolation and movement control, such as:

- Emergency generator sets on Hospitals, data bank organizations or residential areas.
- Pumps or piston compressors that have high eccentricity where a mass of inertia cannot be installed.
- HVAC equipment on Hospitals or residential areas.
- This mount is suitable for the isolation of static rotating machines which are exposed to axial and radial shocks, dripping oil or diesel or exposure to the weathering.



VIDEO TEST

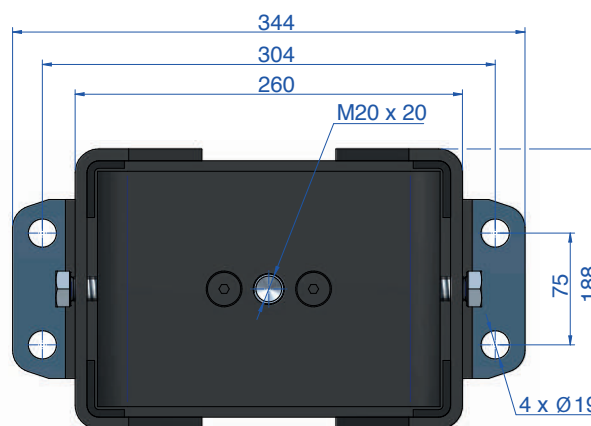
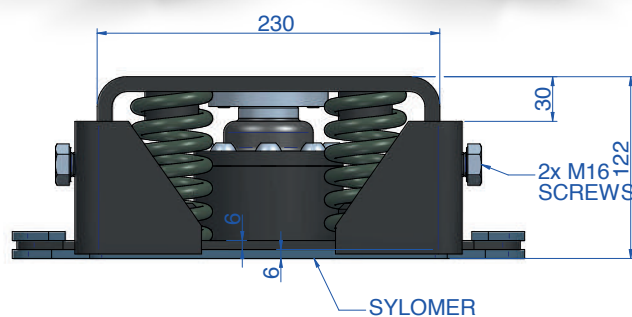
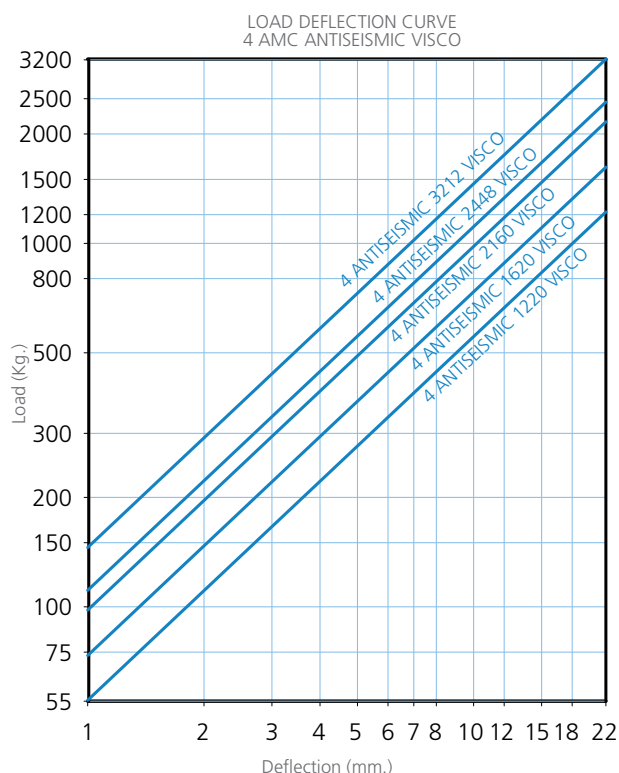
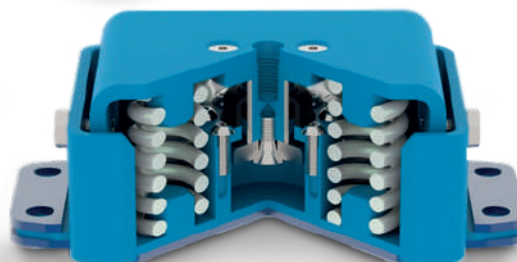

Type	No. Springs	Spring color	DEFLECTION mm	Max. Load (kg)	Code
ANTI SEISMIC VISCO	4	PURPLE	22	1220	21256
	4	GREEN	22	1620	21255
	4	GREY	22	2160	21257
	4	WHITE	22	2448	21258
	4	RED	22	3212	21259

DYNAMIC BEHAVIOUR

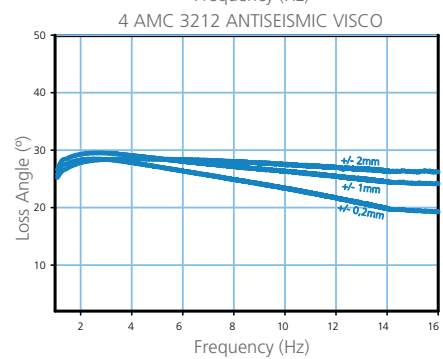
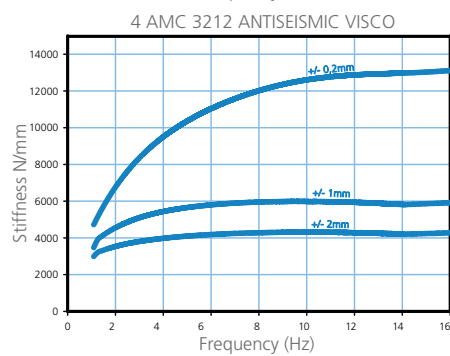
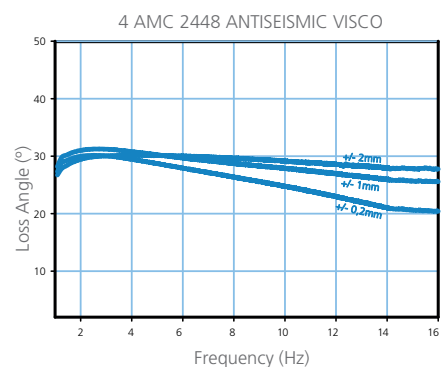
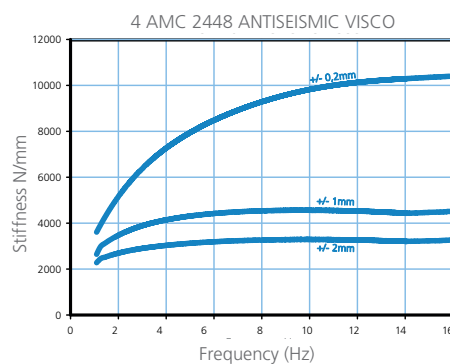
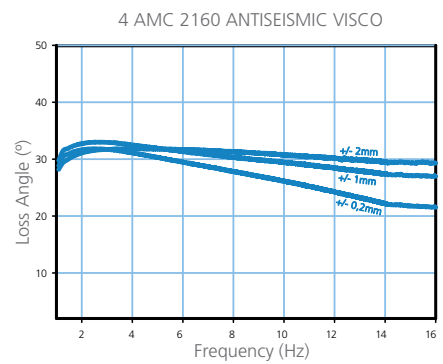
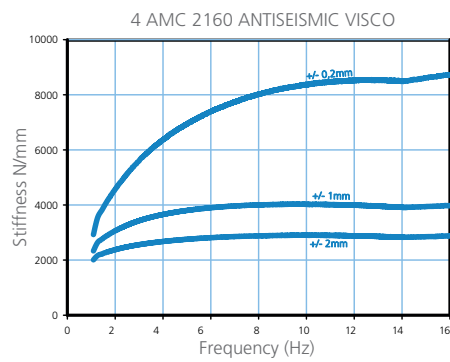
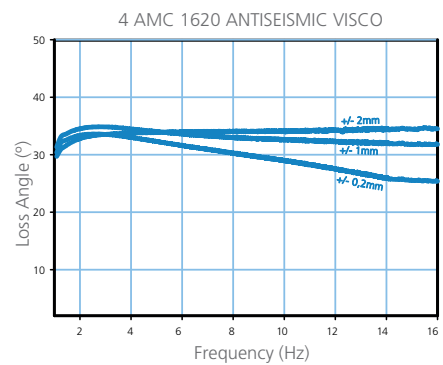
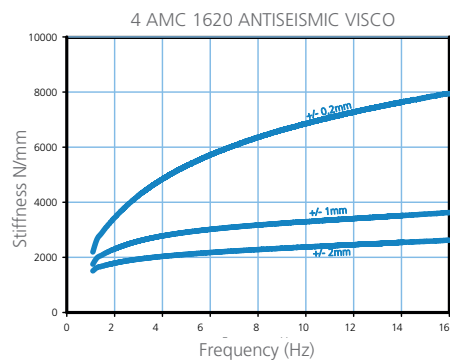
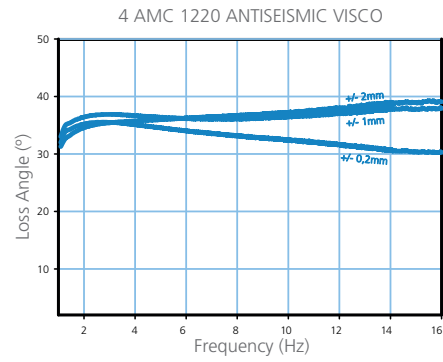
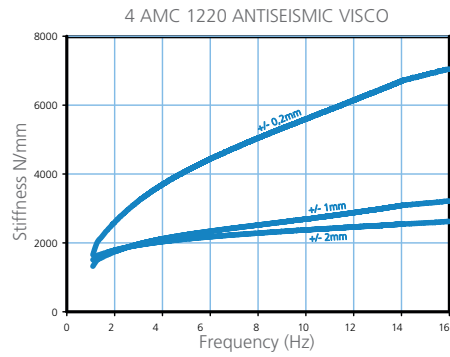

VIBRABSORBER + sylomer[®]

VIBRABSORBER + sylomer[®]

with adjustable damping & vertical displacement end stroke buffer

The Vibrabsorber+Sylomer[®] with adjustable damping system is composed of a damping chamber where the piston can allow more or less viscous fluid transmission. This anti vibration mount has incorporated anti traction buffers of Sylomer[®] to limit the vertical movement of the mount if needed.

The base of the mount includes a layer of Sylomer[®] to reduce the transmission of high frequencies that could go through the coil springs.

The dynamic stiffness and angle loss depends on the amplitude and also on how open the piston orifices are. This can be adjusted by rotating the discs of the piston. This rotation is achieved by turning a central bolt from Minimum to Maximum.

This product is tailored for each application.

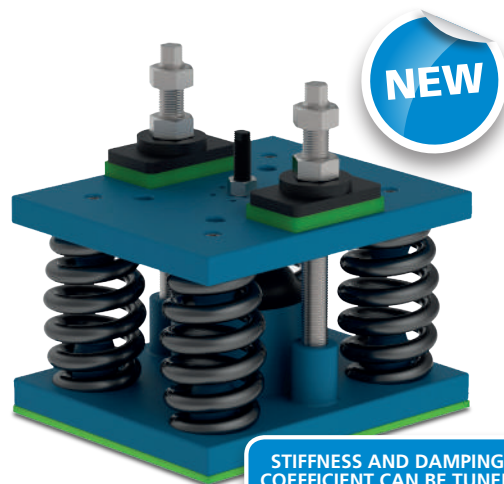

STIFFNESS AND DAMPING COEFFICIENT CAN BE TUNED TO BESPOKE APPLICATIONS.

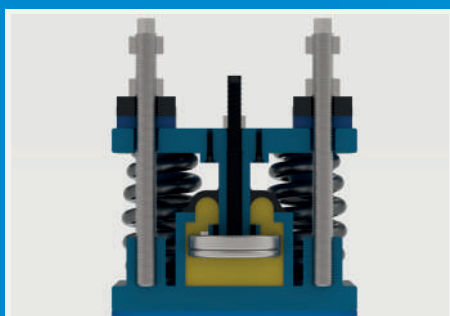

THE DAMPING FLUID IS COMPOSED OF A VISCOUS THERMOSTABLE ELASTOMER. THE RUBBER MEMBRANE IS BONDED TO THE METAL TO AVOID LEAKAGES OF FLUID. THE MEMBRANE ALLOWS TRANSFER OF FLUID FROM CHAMBER TO CHAMBER.

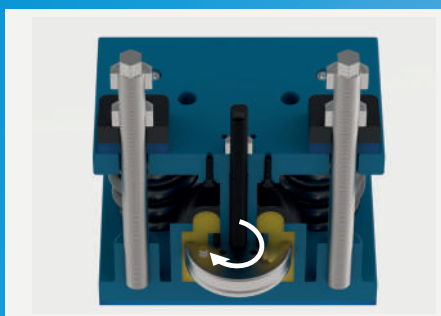

THE DAMPING IS ADJUSTABLE BY A ROTATION OF A CENTRAL BOLT FROM MINIMUM TO MAXIMUM DAMPING.

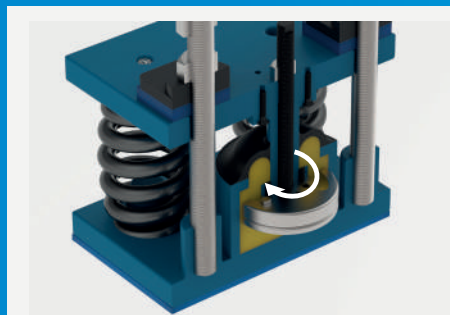

VARIABLE DAMPING IS ACHIEVED BY A ROTATION OF DISCS.



VARIABLE DAMPING IS ACHIEVED BY A ROTATION OF DISCS.





AMPLITUDE DEPENDANT DYNAMIC STIFFNESS
ADJUSTABLE VISCOELASTIC SPRING

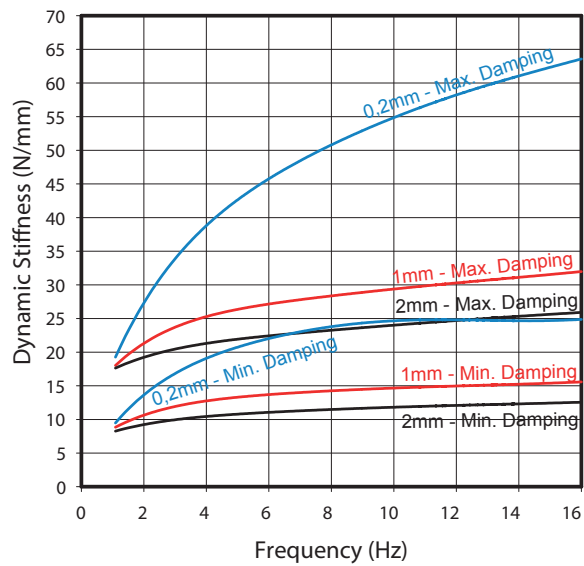

LOAD DEFLECTION CURVE
ADJUSTABLE VISCOELASTIC SPRING

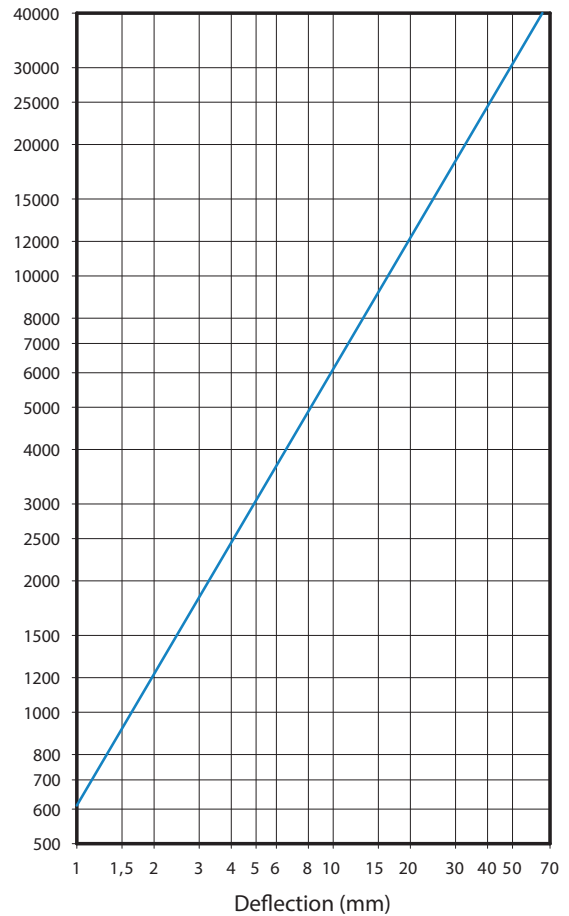

AMPLITUDE DEPENDANT LOSS ANGLE
ADJUSTABLE VISCOELASTIC SPRING

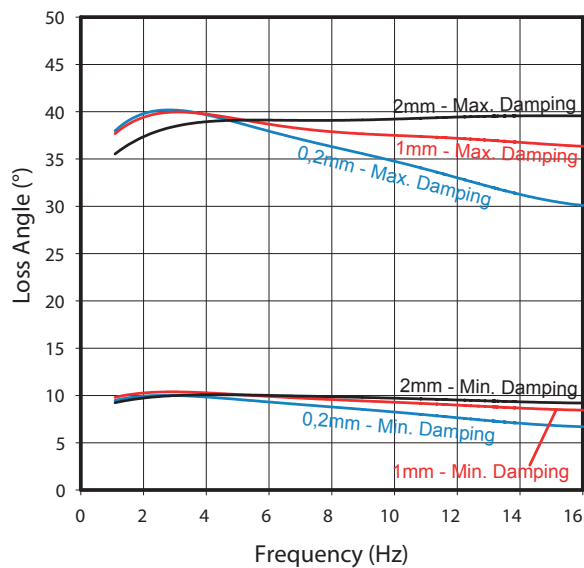

SEQUENCE OF THE ANTISEISMIC MOVEMENT

WATCH THIS MOVEMENT IN VIDEO

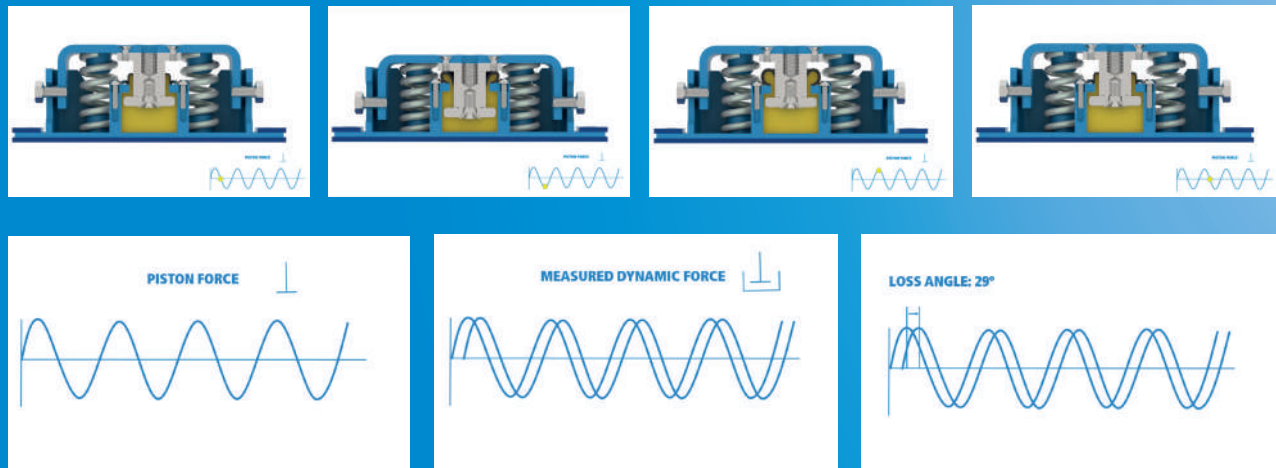

ANTISEISMIC ASSEMBLY INSTRUCTIONS

- Coordinate the location of each mount, depending on the installation drawing or the positions recommended in the theoretical calculations.
- Elevate the equipment and place the mounts under the equipment.
- Lower the equipment and support it on the spring mounts, taking care not to overload any of the spring mounts.
- Turn the leveling screw clockwise on the lowest equipment corner until the equipment is levelled. Do not attempt to place all the weight on any one spring mount, but distribute the load proportionately.
- Continue to turn each leveling screw until the top load plate reaches operating height (see static deflection values of the theoretical calculations).
- Make sure that the M16 Anti-traction screws are correctly installed on both lateral sides of the spring mount. It is not necessary to apply any tighten torque on them.
- When the equipment is completely installed and operating, tighten each M16 nut of the leveling screw.
- Do not attempt to move the isolators laterally with the weight of the equipment on them, in order to avoid any bend or brake of the spring mount housing or slippage of the Sylomer[®] pad and the bottom housing.

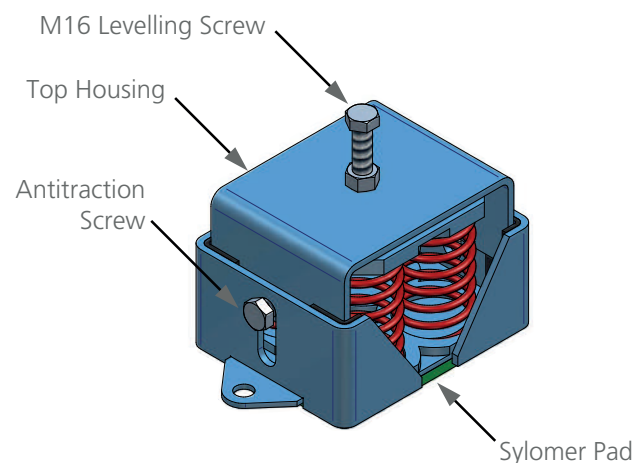
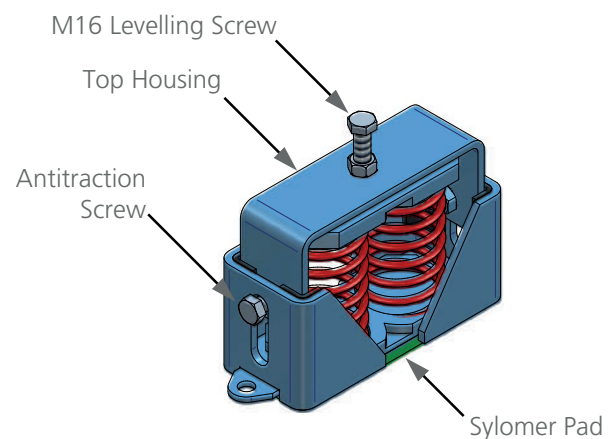

AMC MECANOCAUCHO® ONLINE CALCULATION SOFTWARE

TRAINING WILL BE PROVIDED BY OUR APPLICATION ENGINEERS.

Total Center of Gravity

Xcdg (mm.)	Ycdg (mm.)	Total Mass
860,0000	500,0000	700,00 Kg.

System Loads

Name	x	y	m

AMC MECANOCAUCHO® TECHNICAL SUPPORT								
N°	Code	Description	k (N/mm.)	X (mm.)	Y (mm.)	F (Kg.)	s (mm.)	% MAX.
1	20373	1 AMC 250+Sylomer®	84,60	0,00	0,00	116,67	13,60	46,67
2	20373	1 AMC 250+Sylomer®	84,60	860	0,00	116,67	13,60	46,67
3	20373	1 AMC 250+Sylomer®	84,60	1720,00	0,00	116,67	13,60	46,67
4	20373	1 AMC 250+Sylomer®	84,60	1720,00	1000,00	116,67	13,60	46,67
5	20373	1 AMC 250+Sylomer®	84,60	860	1000,00	116,67	13,60	46,67
6	20373	1 AMC 250+Sylomer®	84,60	00	1000,00	116,67	13,60	46,67

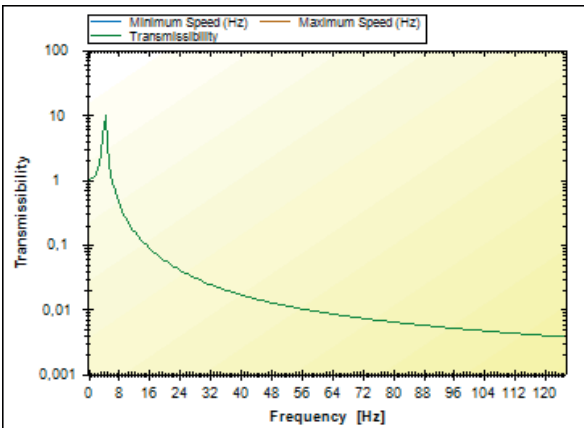
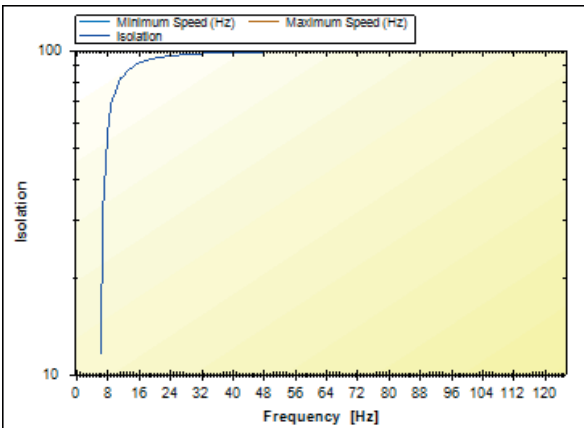

Isolation % for the order 1,00 at 1.500,00 rpm 96,25 %

Do not hesitate to ask us for login details at sales@amcsa.es

	
48 h.	24 h.
72 h.	24 h.

USA DELIVERY

	
4 WEEKS	

San Sebastián
Asteasu



Our stock is at your service.

VIBRATION ISOLATION GRAPH

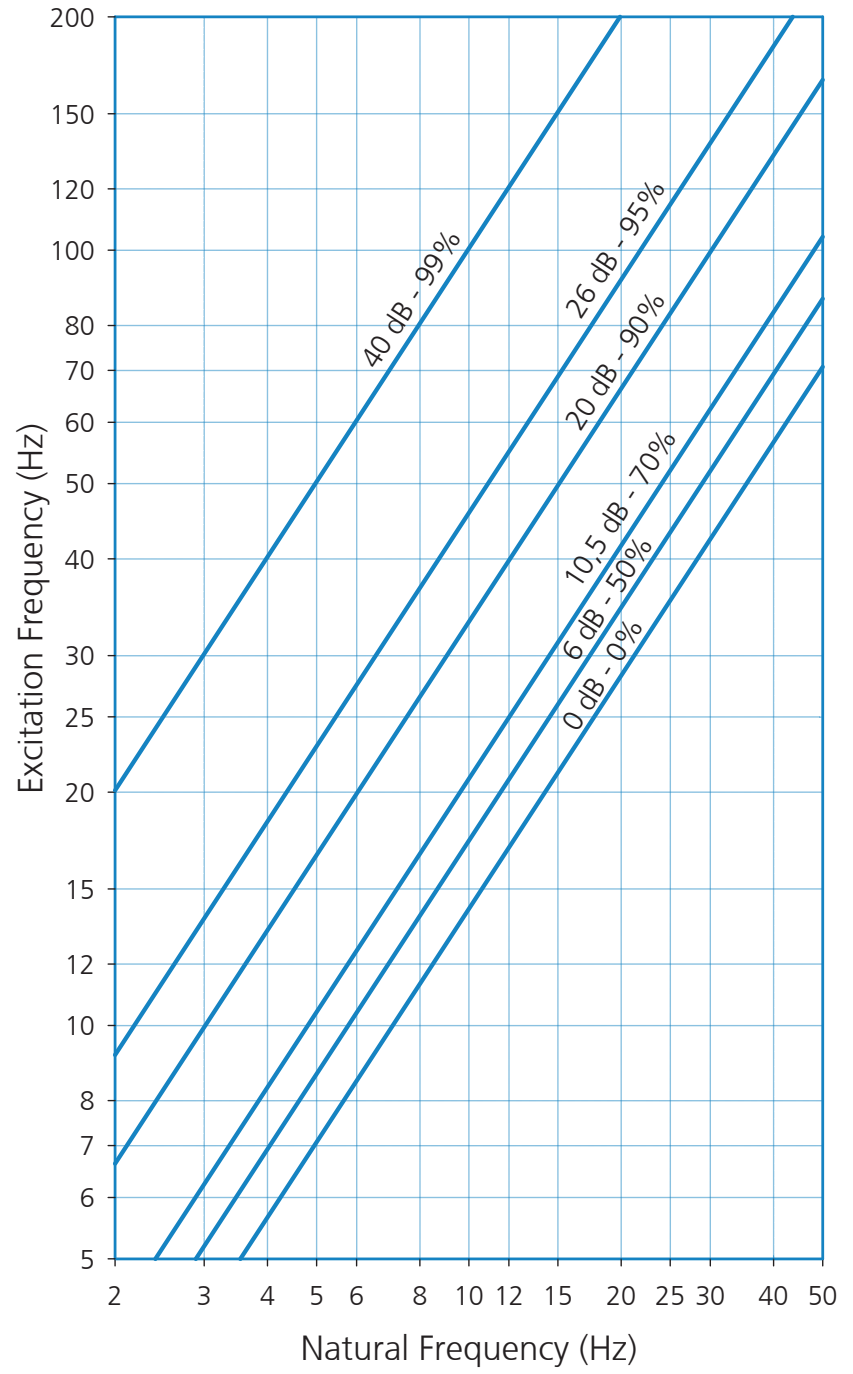

OTHER AMC PRODUCTS



AMC-MECANOCAUCHO® ANTIVIBRATION MOUNTINGS

Rubber to metal mounts for industrial applications.

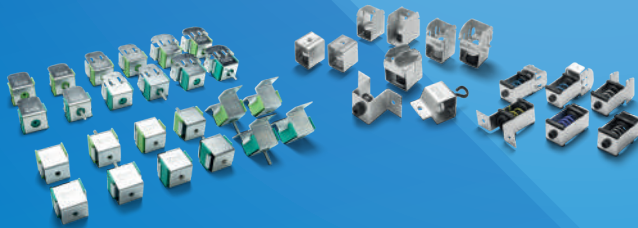

AKUSTIK & AKUSTIK+^{by getzner} **sylomer**®

Optimized acoustic hangers, floor mounts and wall ties for the structure borne noise isolation of buildings and machinery.



^{by getzner} **sylomer**®

Micro-cellular polyurethane material specially conceived for vibration isolation.



Granab® golvregelsystem

Acoustic and technical floor for buildings.

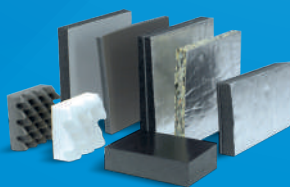

AKUSTIKABSORBER

Soundproofing composites for industrial applications.

DISCOVER OUR **NEW APPLICATIONS**: available at Android and IOS.

VIBRATION ISOLATOR PRO



Let your phone discover **THE MAIN DISTURBING FREQUENCIES** of your application. The integrated accelerometers of your phone are capable of making an FFT measurement where you will be able to see the main frequencies that you need to isolate.



ACOUSTIC HANGER PRO



Discover the app that helps you **FIND THE CORRECT ACOUSTIC HANGER** for your application. Let your phone provide you a full report of isolation, datasheets and installation video. **SIMPLE, EASY & FREE.**



AMC
MECANOCAUCHO

Aplicaciones Mecánicas del Caucho S.A.

Industrialdea Parc 35 A. • E-20.159
ASTEASU (Gipuzkoa) Spain
Tel.: + 34 943 69 61 02 • Fax: + 34 943 69 62 19
e-mail: sales@amcsa.es
www.akustik.com
www.mecanocaucho.com

