

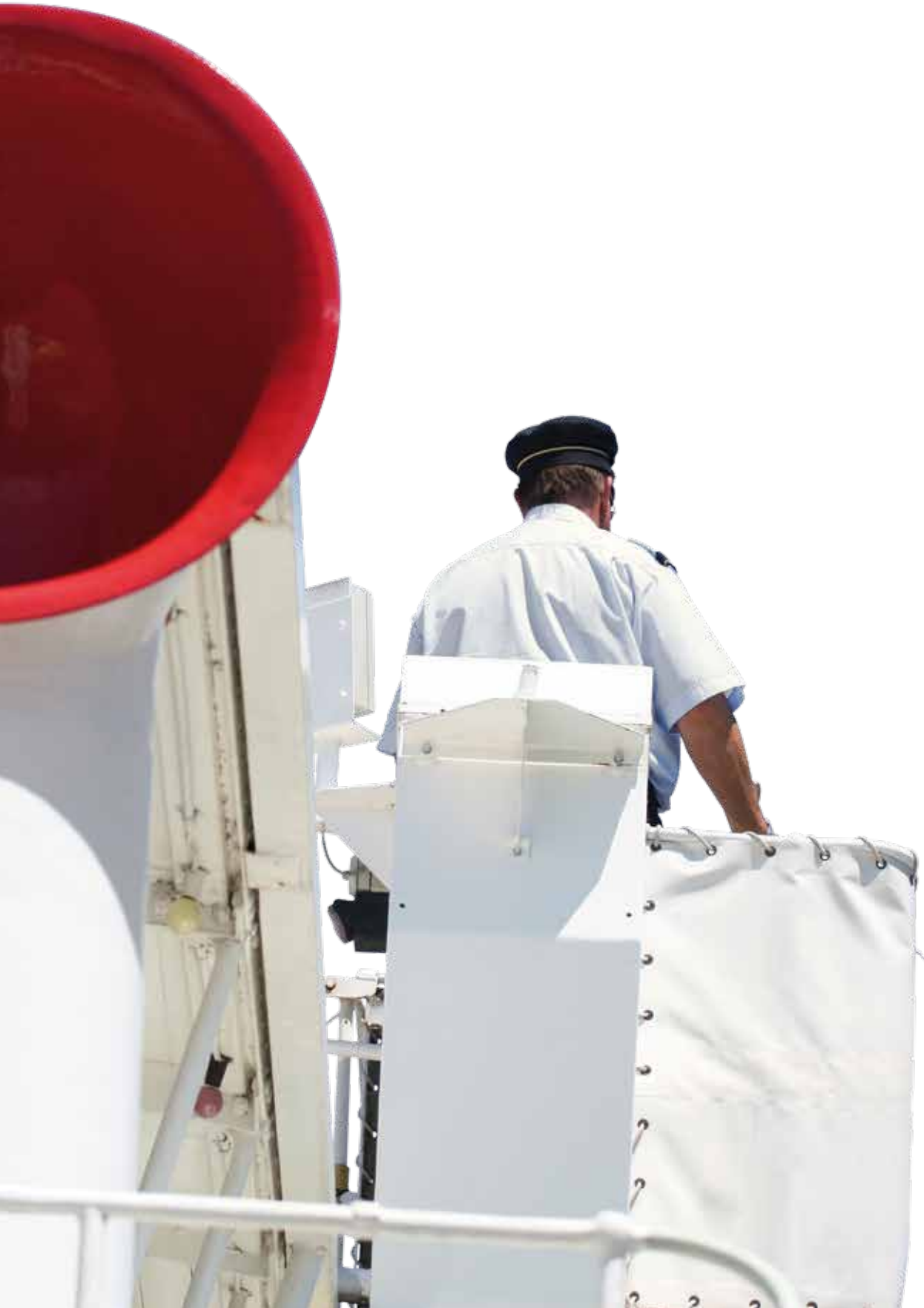

Traffic Engineering

Shipping and Navigation

WAGO[®]



Contents



Innovation from Port to Starboard	4-5
Tough Challenges in Rough Seas	6-7
Commands from the Bridge with the WAGO-I/O-SYSTEM	8-9
Complete Monitoring of a Luxury Yacht - ETHERNET Makes It Possible	10-11
Drive Concept and Energy Management on PlanetSolar	12-13
Ship Monitoring and Control System	14-15
Smart Cabin Automation on Cruise Ships	16-17
Interface Electronic on the High Seas	18-19
Reliable Connections with TOPJOB® S	20-21
Pluggable Safety: X-COM®-SYSTEM and X-COM®S-SYSTEM	22-23
WINSTA® - Pluggable Electrical Installation	24-25
WAGO Product Information	26-27

WAGO – the most dependable partner for shipbuilding technology

Applications in shipbuilding, onshore and offshore industries are particularly demanding of the performance capability and availability of components. Our high-tech components stand up to the most adverse ambient conditions for use at sea. Constant vibrations and impacts, e.g., in the engine room, high humidity and temperatures, salt spray and high demands for electromagnetic compatibility are no problem for these components. They provide fail-safe functioning 24 hours a day for years at a time.



Interface Electronics

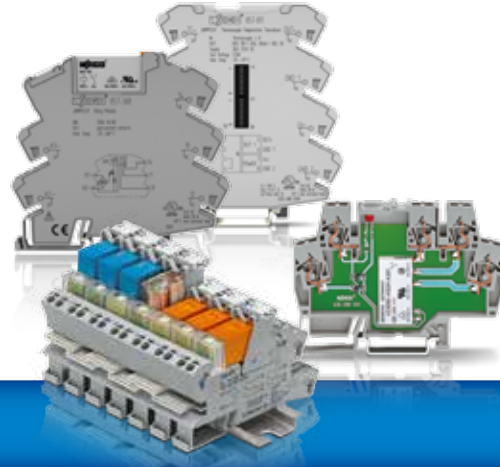

Innovation

from Port to Starboard

From the bridge to the engine room:

Our products for on-board automation systems and offshore applications fulfill all necessary criteria for complex tasks. This has been certified by maritime classification societies such as GL, LR, DNV, ABS, BV, KR, NK, KR, RINA and PRS, and this for the highest environment categories (Cat. D, EMC1). Of special note here is the certification for use on the bridge near the compass – tested and approved by BSH (Federal Maritime and Hydrographic Agency).

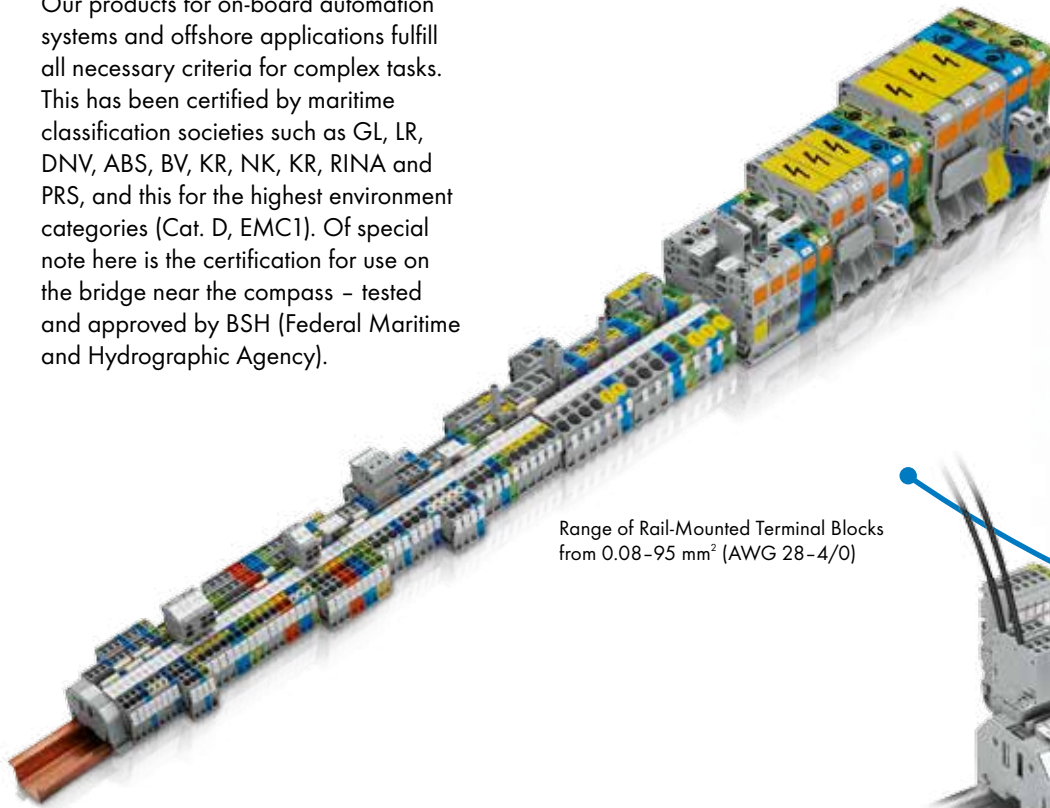

Range of Rail-Mounted Terminal Blocks from 0.08–95 mm² (AWG 28–4/0)

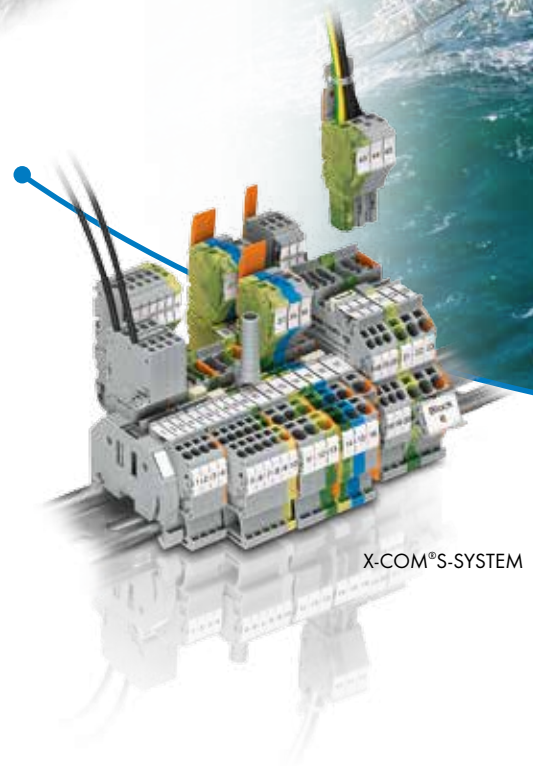

X-COM®S-SYSTEM

WAGO-I/O-SYSTEM

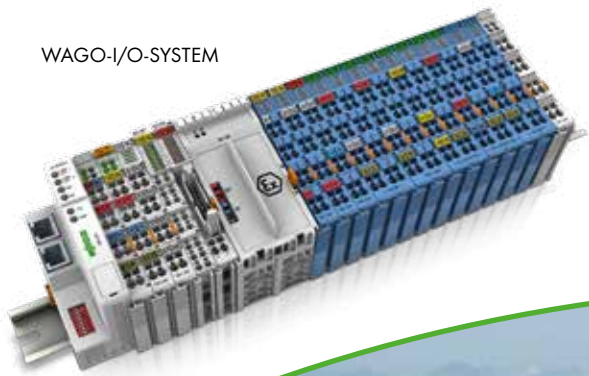

WAGO-I/O-IPC



PERSPECTO® - Panels and Monitors



WINSTA®

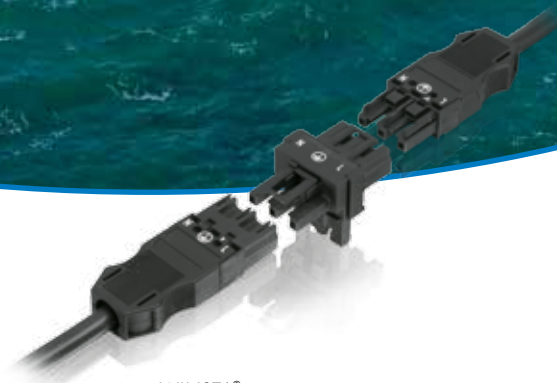

PUSH WIRE® Connectors for Junction Boxes and Lighting Connectors



Quality results from experience and uncompromising attention to detail

As the world market leader and inventor of screwless connection technology, we not only offer the broadest range of rail-mounted terminal blocks with Spring Pressure Connection Technology, covering a wire range between 0.08–95 mm² (AWG 28–4/0), we can also boast that years of experience have proven that our maintenance-free clamping units stay tight, even after 35 years.

WAGO used this as the basis for developing inhouse quality standards that far surpass those required by the pertinent standards.

All WAGO products must pass numerous tests and intense examinations for this. Automation components, for example, are tested in our inhouse EMC lab for their electromagnetic compatibility.

Only when our products have passed numerous tests and examinations and, thus, meet our stringent quality demands, are they good enough for our customers.



EMC tests

Tough Challenges in Rough Seas

Proven quality thanks to certified processes and products

We do not just give you our promise of meeting the highest quality demands, you also get this in black and white in the form of internationally recognized certificates: Beyond the requirements prescribed by DIN ISO 9001:2000, ISO 14001 and IRIS, WAGO also fulfills the requirements set forth by all requisite maritime approvals:

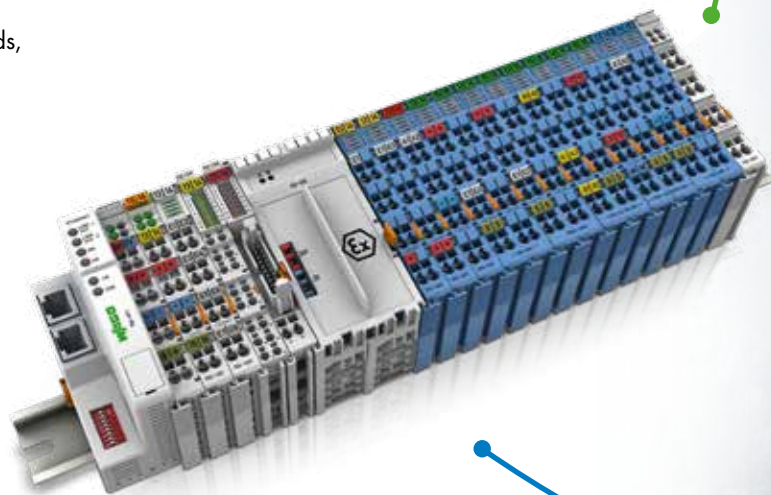

Climatic chamber



Vibration test



Salt spray test



Gastight clamping unit

Commands from the Bridge

with the WAGO-I/O-SYSTEM



Compact industrial PC

Fieldbus-independent
 The system's modularity is also reflected in its support of numerous fieldbus systems. Depending on the application, it is possible to choose between fieldbus couplers and controllers for different protocols.

Automatic connection
 Power jumper contacts automatically provide both internal data transmission and electronics supply in addition to potential distribution.



Fieldbus coupler

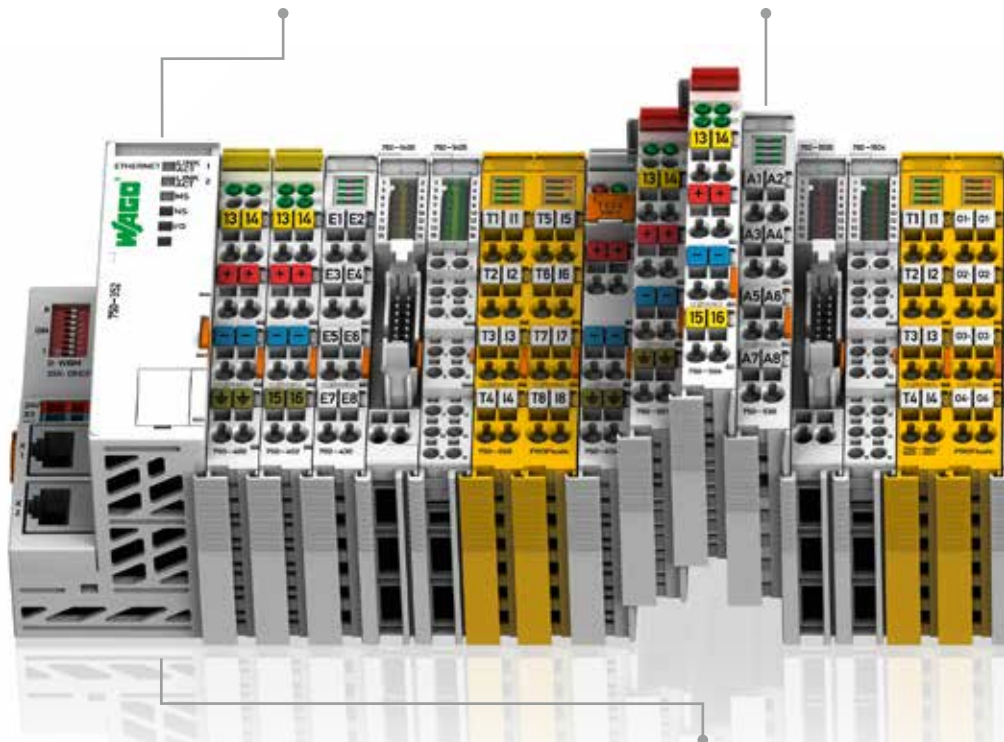

Programmable fieldbus controller

Scalable performance
 Configuration, programming and visualization are performed using the WAGO-I/O-PRO CAA software package based on IEC 61131-3 (CODESYS).

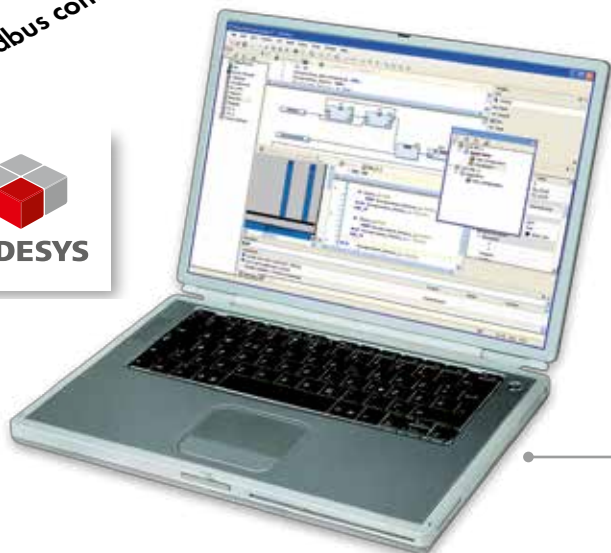
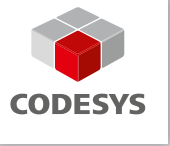

Clear identification

Pullout group markers allow color identification of module functionality. Connector assignment and technical data are located on the side of the module. The WAGO WSB marker system also allows for module- and channel-related identification.

Pluggable connections

For the ultimate in convenience, the 753 Series I/O modules are compatible with the 750 Series I/O modules, which enables the use of 753 Series pluggable connectors. An integrated swing arm acts as a separate wiring plan, which allows an operator to easily replace a module without removing and then rewiring all pre-existing wiring. This virtually eliminates handling errors and saves time - if needed, this can be executed via place holder modules.

Secure and reliable connections

WAGO Spring Pressure Connection Technology guarantees continuous operation, even under extreme environmental conditions, such as thermal cycling, shock, vibration, and electrostatic discharge (ESD). Spring contacts guarantee continuous operation.

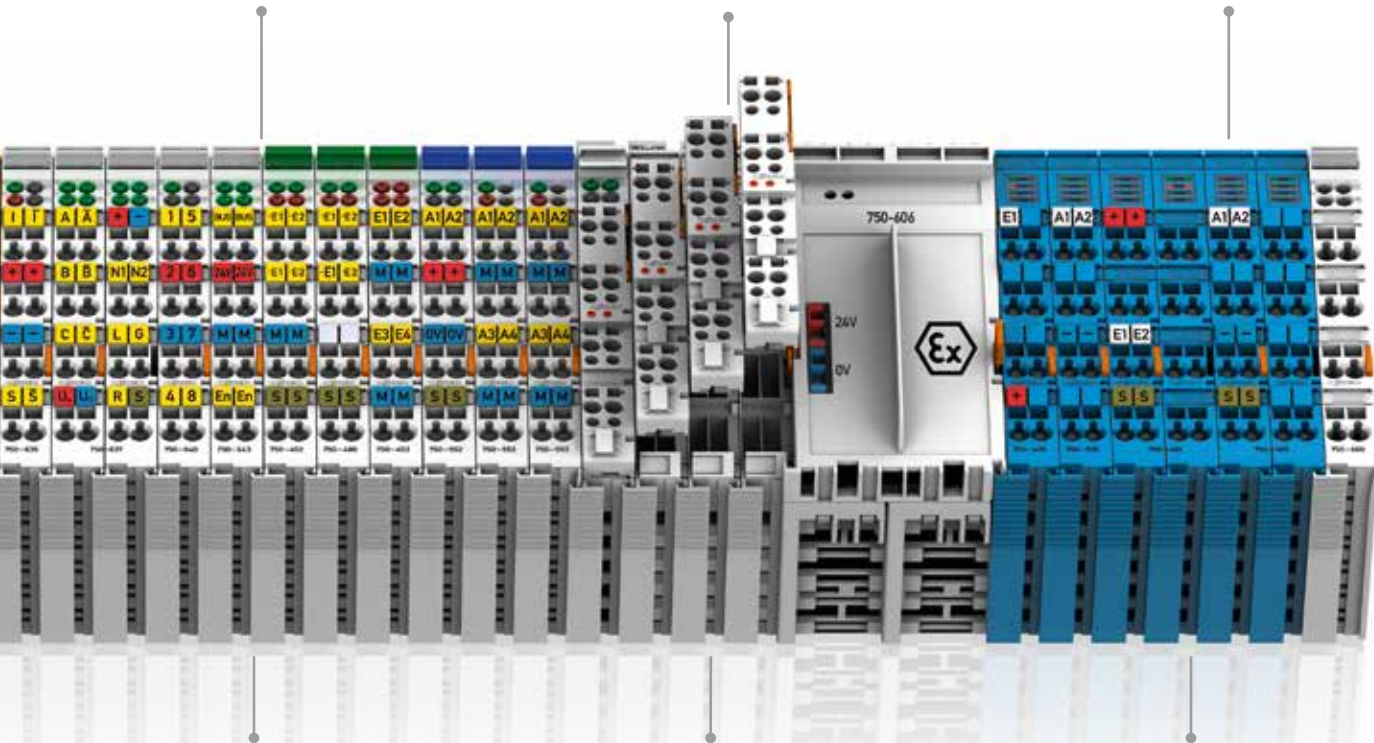

Compact size

Our patented mechanical design allows for extremely compact I/O nodes. I/O modules can accommodate up to 16 channels in a 12 mm (1/2") wide housing.

Simple handling

The DIN-rail-mount and modular design of the components guarantees easy handling, without the need for tools.

Highly flexible

Each node in the WAGO-I/O-SYSTEM can be configured to meet each channel's requirements.

The most compact, modular and fieldbus-independent I/O system for decentralized automation

The WAGO-I/O-SYSTEM has been approved for the toughest tasks from the bridge to the engine room and has also proven its suitability for such uses through years of practical use.

- International approvals: GL, LR, DNV, BV, RINA, KR, NK, BSH
- IEC-60945-compliant
- Environmental category D (GL), EMC 1 (direct operation on combustion engines and compressors)

- Unrestricted use on the bridge "Compass Certificate" (BSH)
- Gateway functions: NMEA, J1939, MODBUS-RTU.

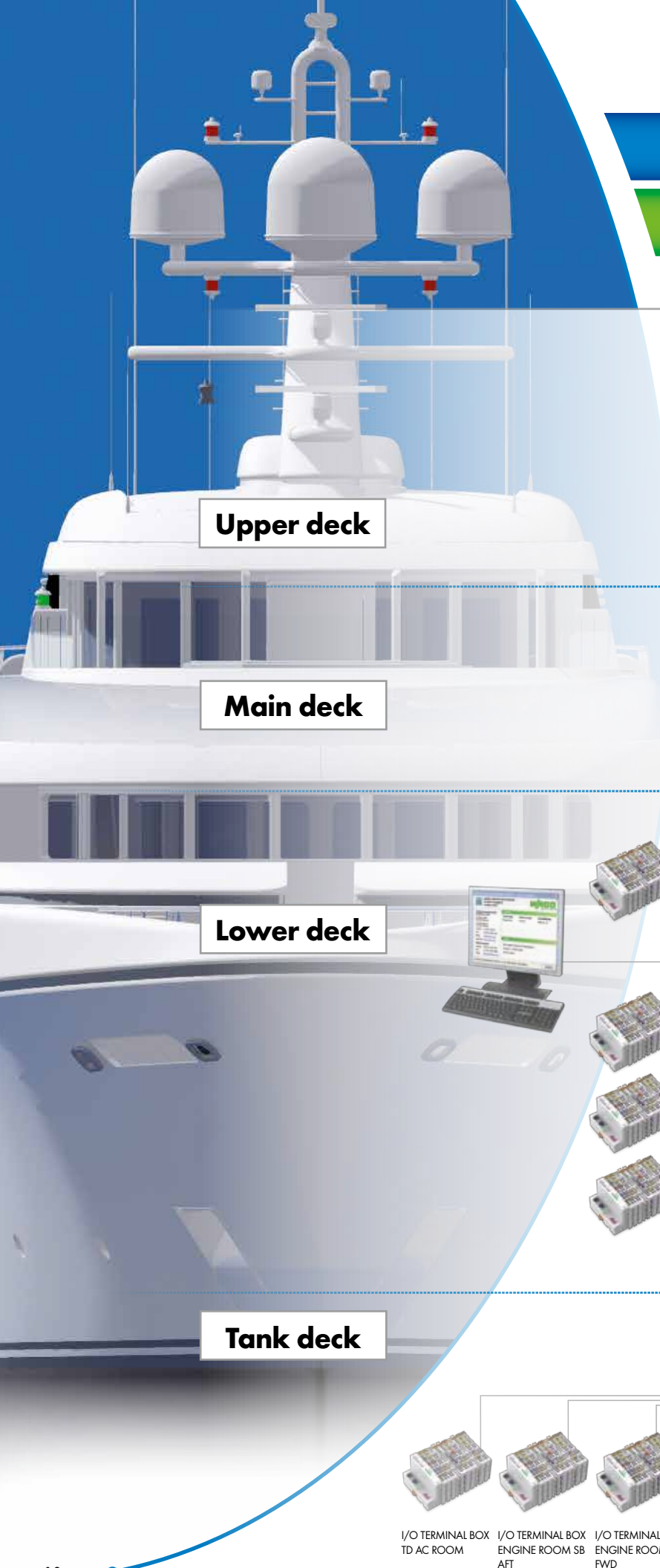

Upper deck

Main deck

Lower deck

Tank deck

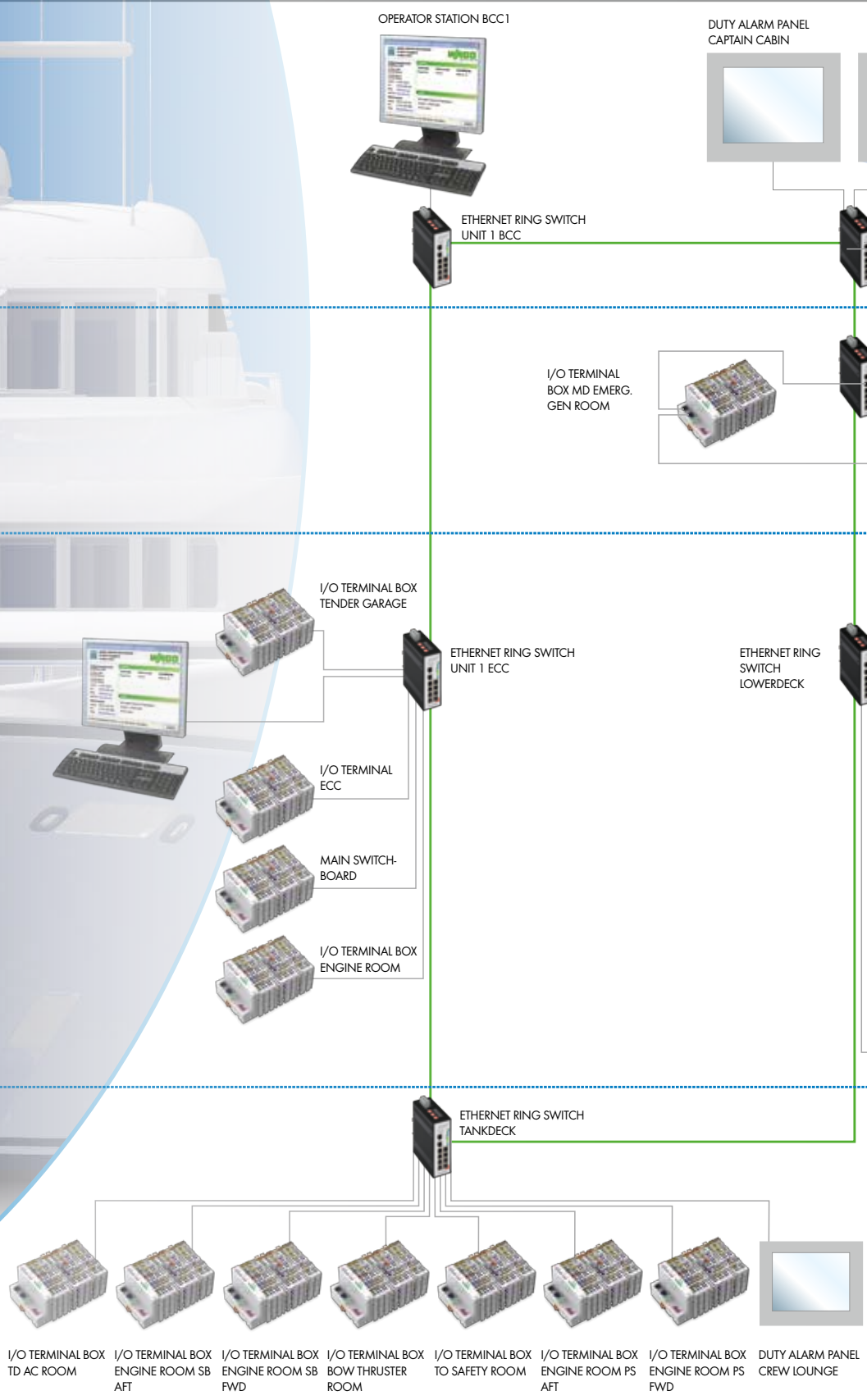

Complete Monitoring of a Luxury Yacht

ETHERNET Makes It Possible

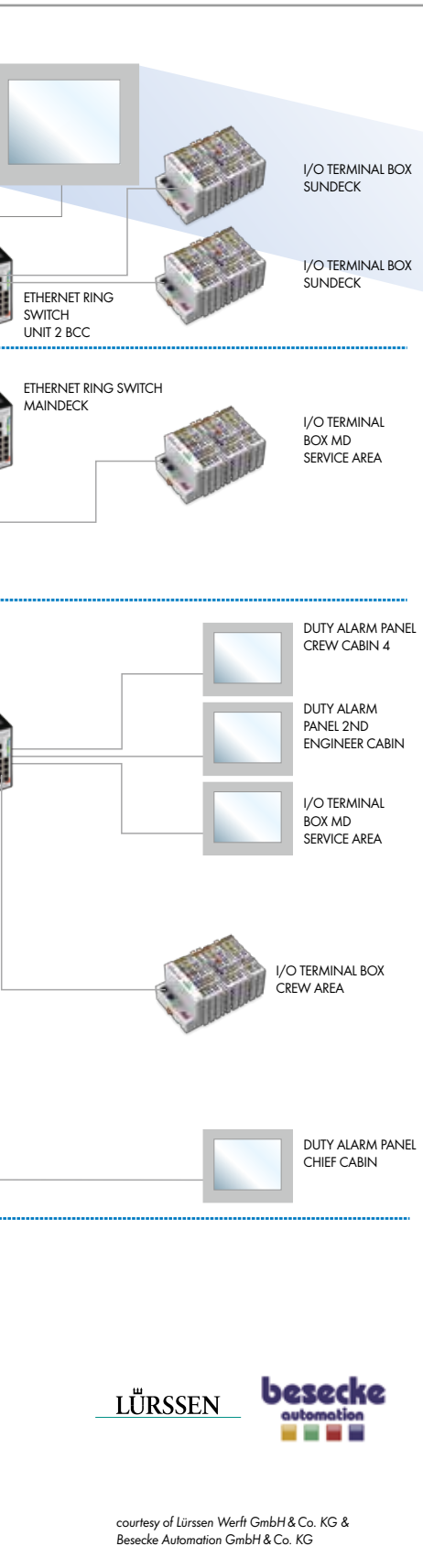

Blazing new trails for on-board automation systems

Open, standardized ETHERNET communication protocols offer the ideal platform for handling of complex control solutions. This provides crucial technical and economic advantages for commissioning, configuration and service (e.g., via standard IP protocols such as HTTP, FTP, SNMP).

The Besecke company plans, develops and, with the aid of the WAGO-I/O-SYSTEM, builds integrated monitoring systems for luxury yachts and employs intelligent, locally installed ETHERNET controllers for this. These controllers monitor and control the power supply, lighting/air conditioning, tank/ballast systems and door/bulkhead systems, and many other systems, via redundant (where required) ETHERNET infrastructures. Various serial sub-bus devices can also be integrated into the system via gateway I/O modules using different protocols, such as NMEA, Modbus RTU.

This concept's modular control architecture enables its scope to be easily scaled for use on yachts of varying sizes and complexity.

The intelligent ETHERNET controllers communicate with one another via Modbus/UDP (P-2-P), and each controller can communicate with the other units as a master and/or as a slave (client or server). Status messages between groups of controllers are also synchronized using CODESYS network variables via a "broadcast" service to create redundancies, which enhance system availability without having the need for additional hardware. The measured data and alarm values are provided for visualization at the monitoring stations via an OPC server interface, meaning that they can be generated automatically and, thus, in a time-saving manner from the project data.

Besides the numerous certificates for use of the WAGO-I/O-SYSTEM (from the bridge down to the engine room), continuous operation on several Lürssen yachts over a number of years attests to the suitability of the components with regard to immunity to electromagnetic interference, emission of interference and mechanical stress under adverse ambient conditions.

Drive Concept and Energy Management on Planet Travelling Around the World with WAGO IPCs and

PlanetSolar – Raising the bar for use of renewable energy sources

On May 4, 2012, the world's largest solar-powered ship arrived in the Monaco harbor after a journey of 60,023 km, completing the first successful solar-powered journey around the globe.

The ship is shaped like a manta ray, with 500 m² of solar panels on its back.

The DRIVETEK and MAR companies placed their trust in WAGO automation and interface technology in the development of the innovating and highly efficient drive and charging system.

WAGO 758 Series IPCs, which function as the masters in a redundant setup for a network of programmable WAGO ETHERNET controllers and CANopen fieldbus couplers, are used both for the innovative charging management system (Maximum Power Point Tracker) with daily peak loads of more than 600 kWh, and for the highly efficient and entirely newly developed drive system. All of the components offer the appropriate type approval for the categories used in this application and impressively proved their suitability and robustness for use under demanding 24/7 conditions.

Some key figures:

Length: 31 m
 Width: 15 m
 Length with flaps: 35 m
 Width with flaps: 23 m
 Height: 7.5 m
 Weight: 85 t

Surface of solar modules: 536.65 m²

PV panel efficiency: 18.8 %

Average speed: 7.5 Kn (14 K/S)

Maximum speed: 14 Kn (26 K/S)

Drive Concept of PlanetSolar

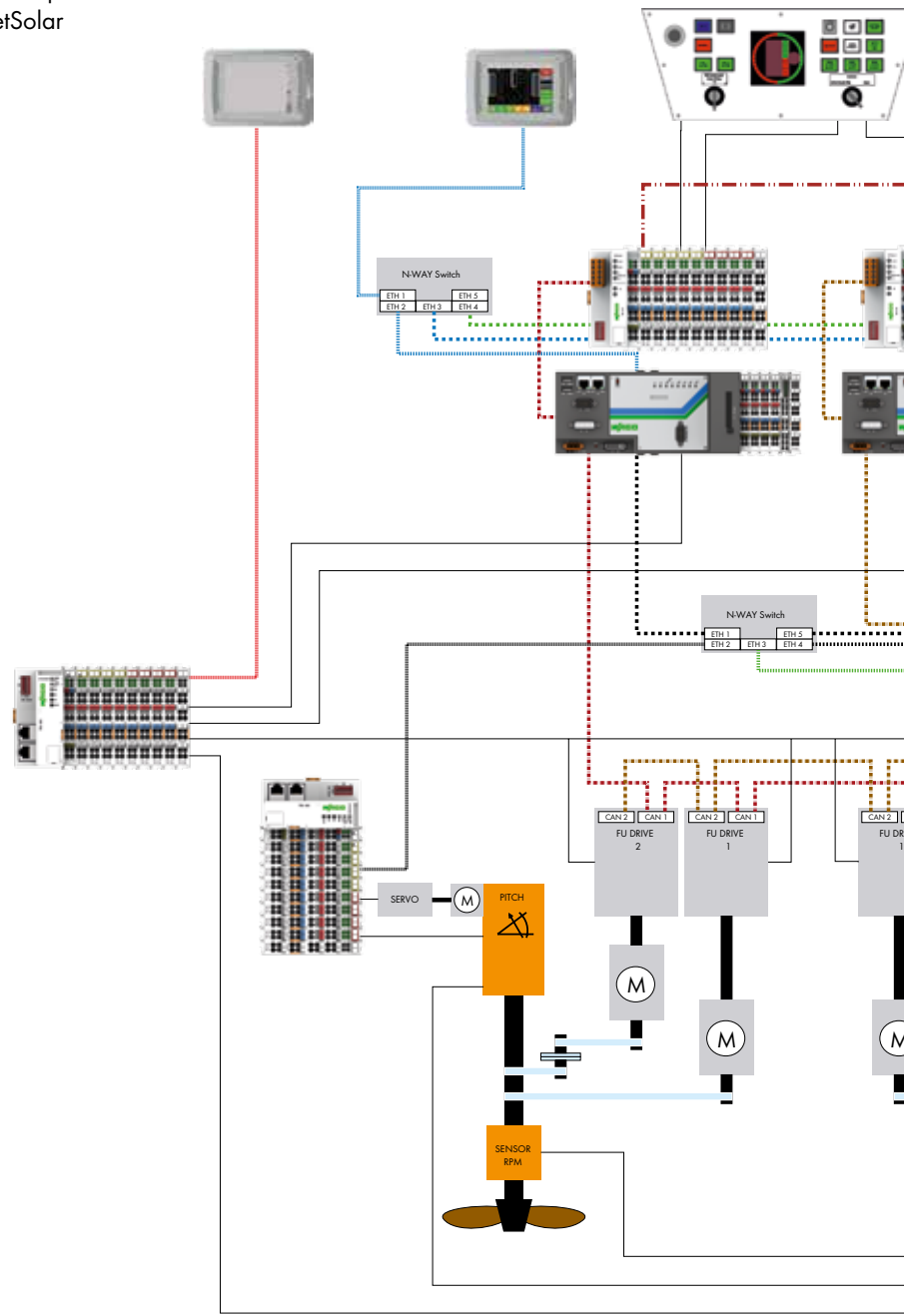

Solar Controllers ...

Crew: 3-4 skippers
 People that can go onboard: 40
 Noise level on board: none
 Emission/pollution: none
 Autonomy: 3 days at 7 Kn without light,
 never-ending solar navigation

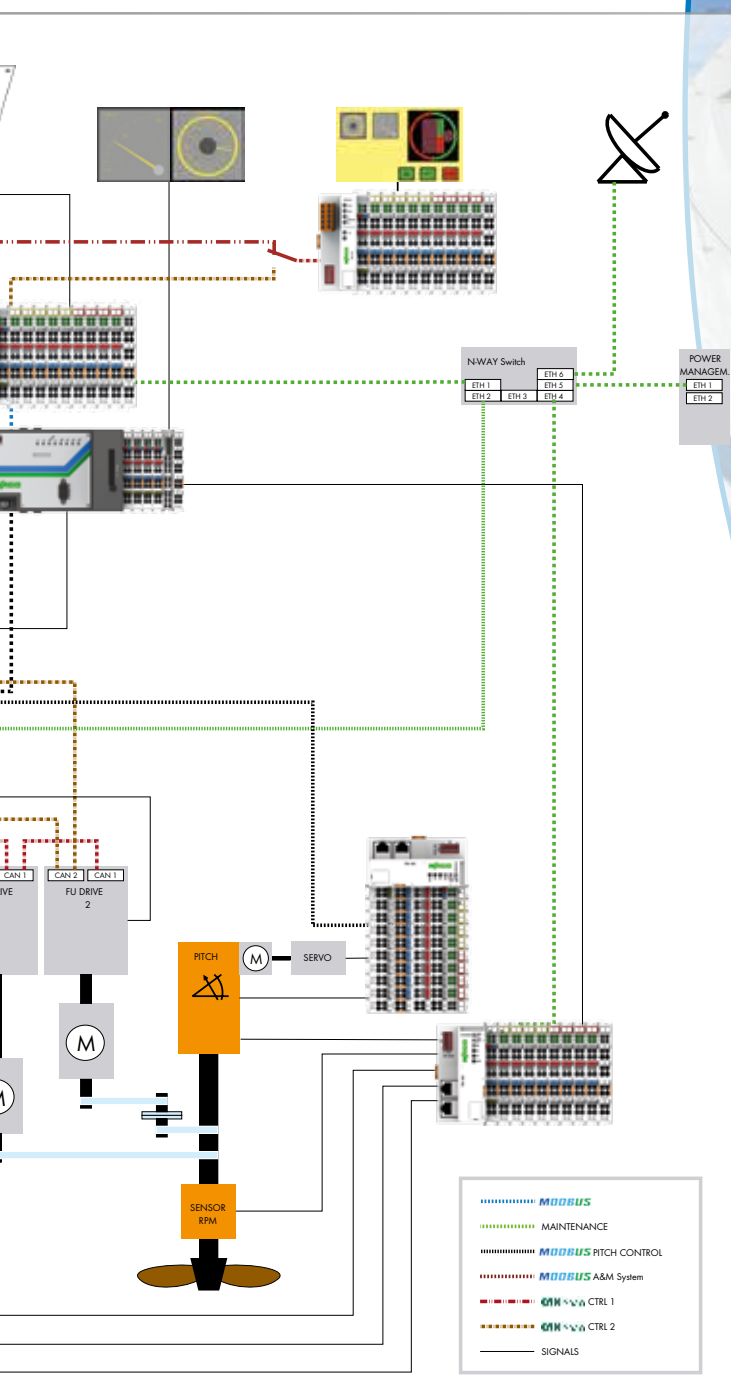

Ship Monitoring and Control System

750-882 ETHERNET Medium Redundancy Controller

Redundant controller networks guarantee high availability of the entire system for on-board ship automation tasks.

The effort required for a redundant controller network on a ship can be reduced when the automation device possesses two independent network ports and when the user program makes redundancy decisions. Meeting these requirements allows both standard components and protocols to be used for the networks.

The WAGO 750-882 ETHERNET MR Controller with redundant LAN ports is particularly well-suited for this type of

use. Redundant process data communication via Modbus/TCP/ UDP and CODESYS network variables is supported.

The controller can act as a master and/or slave (client/server) in this process. This, in turn, enables extremely flexible and customized configuration of the redundancy scenario.

When used as the network master during operation, the controller can switch to the other LAN link (via the application program) in the event of a fault.

As an alternative, master controllers can also read and write simultaneously via both LAN links. The programmable slave controllers can decide in this process ("voting") what data is to be processed via which port.

The Freetechnics company uses the 750-882 Controllers for redundant linking to the automation and navigation software from FT NavVision.

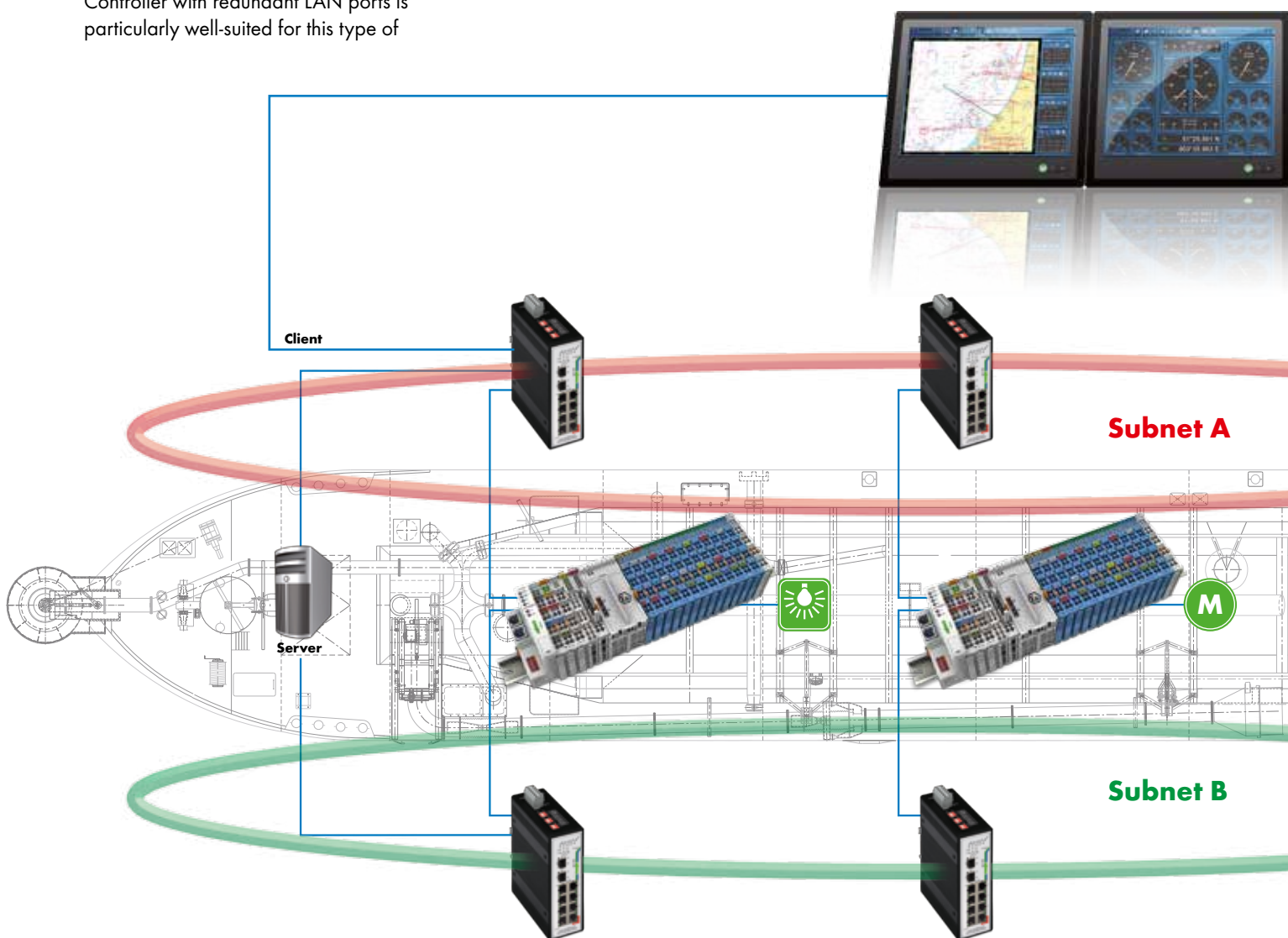



Imtech

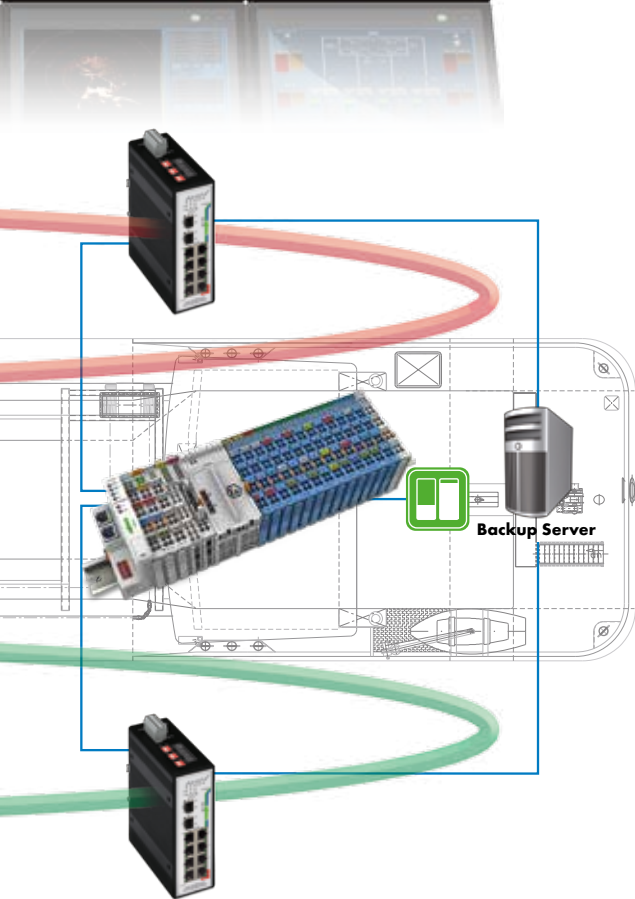
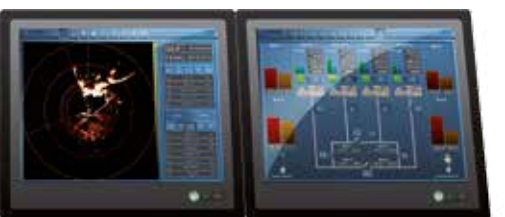

Independent ETHERNET cabin controllers

WAGO ETHERNET controllers are used for automation and networking of the individual cabins on cruise ships from the "Meyer Werft" shipyard, with the independent cabin controllers assuming the tasks of access, air-conditioning and lighting control.

The decision was made to use an ETHERNET-based solution, which, in turn, enabled tried-and-tested and standardized network technology to be employed.

This allows for cost-effective configuration, installation and commissioning of very complicated networks in particular.

This technology can be used to conveniently load updates (from a central location) to the controllers.

Status information is available at all times throughout the system, contributing significantly to the high level of overall availability of the system.

Central functions enable individual or group execution of actions, such as switching of lighting.

Smart Cabin Automation on Cruise Ships

Integration of Distributed WAGO ETHERNET Controllers

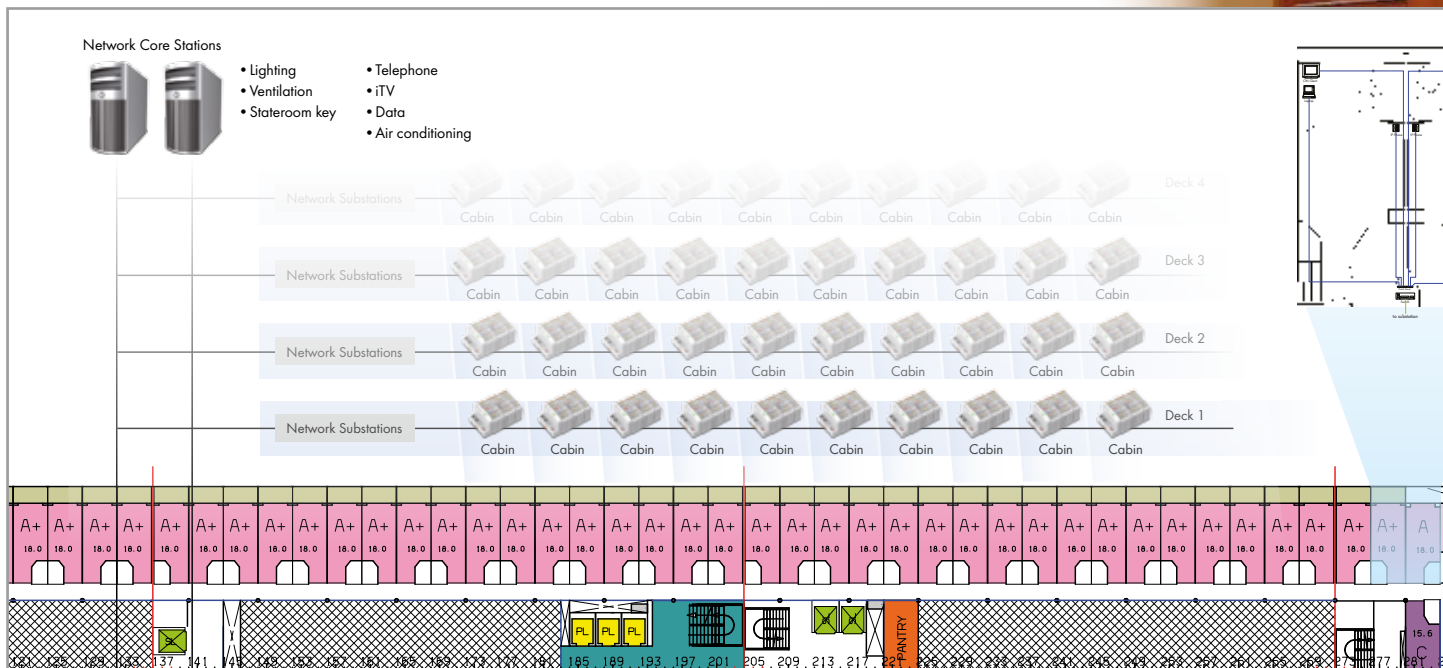
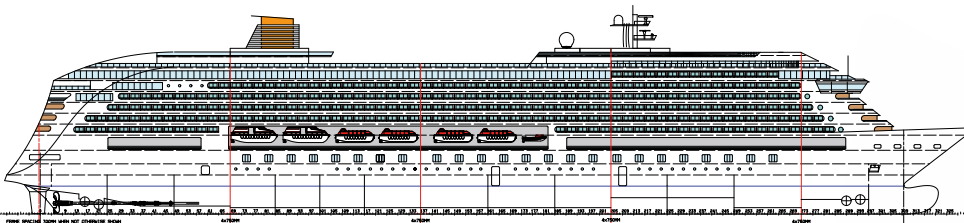

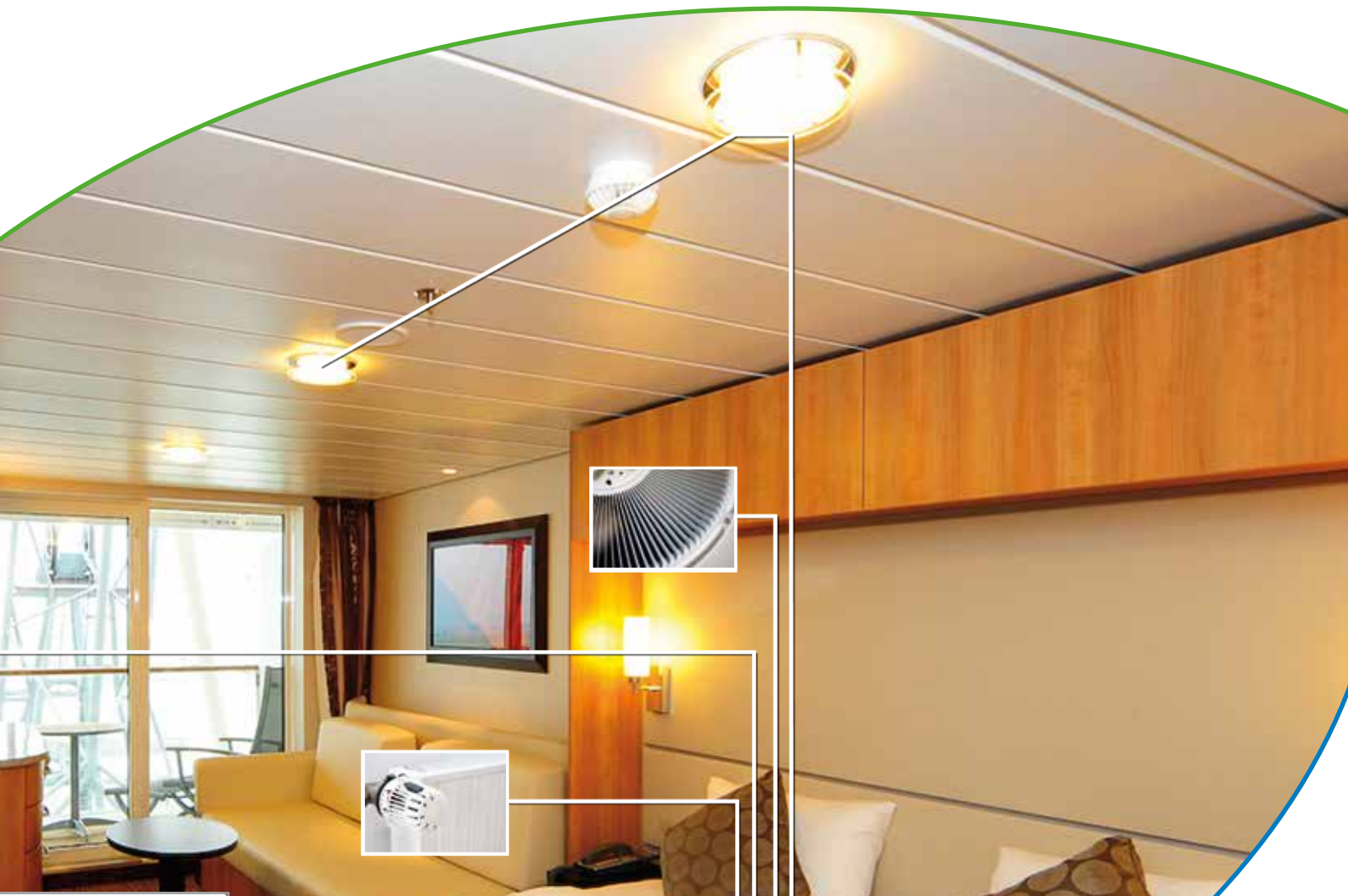

The appropriate interface for every application

Applications in shipbuilding demand that the most varying requirements be taken into account, such as:

- High level of operational reliability and availability
- Easy planning and commissioning
- Ease of use, easy to maintain

Here, WAGO offers a wide variety of useful "Interface Electronic" modules for power supply, measurement, connecting and switching applications. All "Interface Electronic" modules come equipped with fast, reliable and maintenance-free CAGE CLAMP® connection technology.

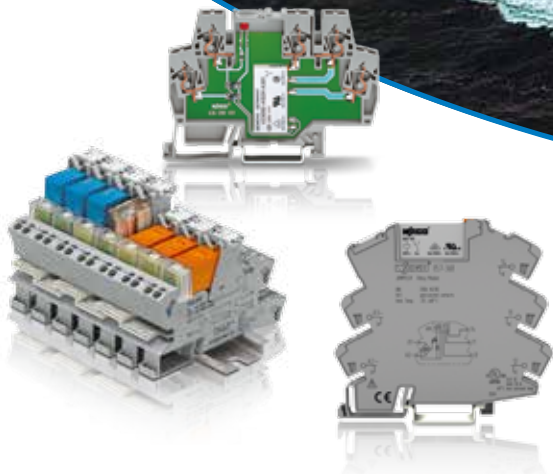

Switching

Relays and optocouplers are used to ensure the break-down into control and load current circuits, to enhance the signal-to-noise ratio and to provide for safe electrical isolation. GL-certified switching modules of WAGO 788, 857 and 859 Series prove their use here.



Measurement

A variety of transducers are in use between the field or sensor level and the control level for adjustment, filtering, gain and electrical isolation tasks. The *JUMPFLEX*® 857-4xx and -8xx GL-approved transducers, with a width of just 6 mm and common profile for push-in jumpers, stand out thanks to their wide power supply and temperature ranges, their calibrated, switchable signals and their consistently outstanding technical data.

Interface Electronic on the High Seas



Power supply

Electric and electronic automation components require reliable power supply with direct current. The *EPSITRON*® COMPACT Power 787-10xx and *EPSITRON*® CLASSIC Power 787-6xx family of power supply units fulfill all GL requirements and provide 12 V, 24 V and 48 V DC power at currents of 1.3 A to 10 A.

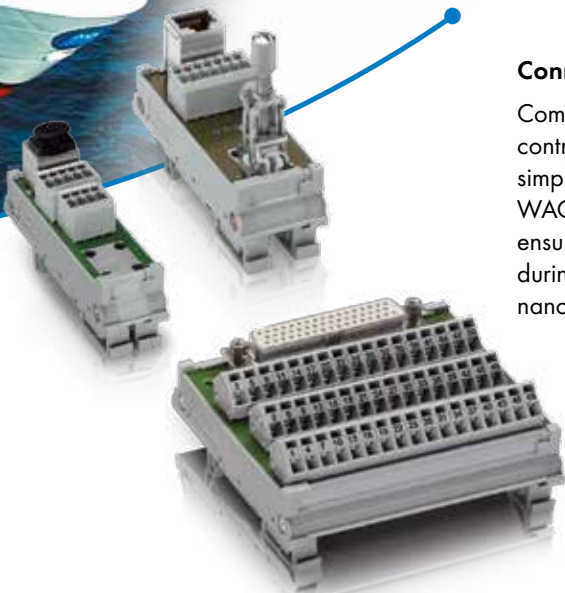

Connecting

Commoning of signals between the field, control and management level must be as simple and as cost-effective as possible. *WAGO 289 Series* interface modules ensure time-saving linking of the levels during installation and safe and maintenance-free connection during operation.

Reliable Connections with TOPJOB® S

The Modern Rail-Mounted Terminal Block System for

On account of the aggressive environmental conditions that often exist on ships (e.g., salt spray), the requirements placed on corrosion resistance, vibration and impact resistance and easy handling of electrical connections are extremely stringent in the shipbuilding industry.

Thanks to CAGE CLAMP® S connection technology, WAGO TOPJOB® S rail-mounted terminal blocks fulfill these requirements. This sophisticated technology makes frequent maintenance and troubleshooting a thing of the past.

TOPJOB® S - The modern rail-mounted terminal block system for shipbuilding.



Thanks to CAGE CLAMP® S technology, TOPJOB® S DIN 35-rail mount terminal blocks are the industry's most compact:

CAGE CLAMP® S connection for all conductor sizes between **0.14–25 mm²** (AWG 24–4)

- Simple, push-in termination of solid and ferruled conductors
- Compact design saves a great deal of space
- Robust and comprehensive jumper system can be loaded with the full nominal current for the module
- Up to three-line marking for even better clarity
- All through and ground conductor terminal blocks are certified for hazardous areas

TOPJOB® S, 2000 Series:
Just 3.5 mm (0.138 in) wide

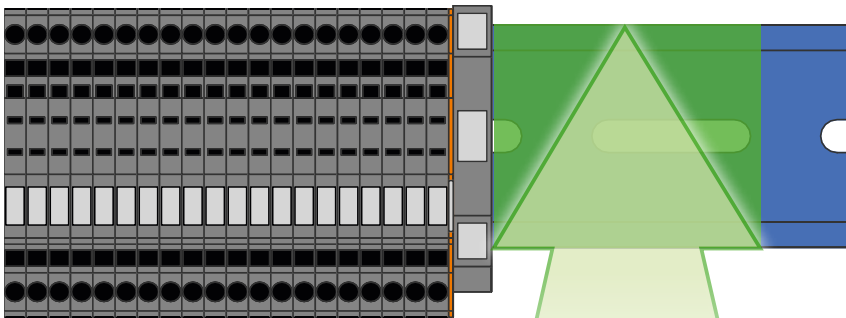

TOPJOB® S, 2002 Series:
Standard width of 5.2 mm (0.205 in)

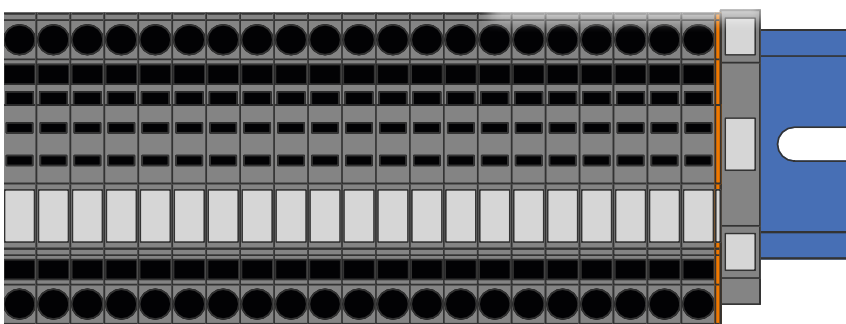

Shipbuilding



- **POWER CAGE CLAMP** - High-current rail-mounted terminal blocks up to **185 mm²** (AWG 4/0)
- 1000 V rated voltage/232 A nominal current



A further advantage of the TOPJOB® S rail-mounted terminal block system:
The fastest and most cost-effective **marking system**

Pluggable Safety: X-COM[®]-SYSTEM and X-COM[®]S-

Preassembly and Mismatching Protection Save Time

Why plug-in connections?

The working space available on board is very limited. On-site wiring in the shipyard is also very expensive. Using connecting systems you can exploit the benefits of preassembly and a number of other advantages:

- During Production
Preassembled part assemblies can be tested before assembly
- During Installation
Preassembly and mismatching protection save time and money
- For Operation and Maintenance
Modules can be exchanged very quickly and without any errors

Reap the benefits of our comprehensive X-COM[®] and X-COM[®] S pluggable connection system and implement your application easily, safely and quickly.



Owing to their identical profile, the pluggable X-COM[®] S and TOPJOB[®] S rail-mounted terminal blocks are compatible with one another.

The X-COM[®]S-SYSTEM, for example, profits from the wide range of accessories for the TOPJOB[®] S rail-mounted terminal block family for commoning and marking. Both of these systems can be individually combined for your specific application.

The X-COM[®] S pluggable rail-mounted terminal block system is available as 1- to 15-pole versions and can be arranged while maintaining the pin spacing.

The system is available with two different terminal block widths:

- 3.5 mm (0.138 in) for conductors up to 1.5 mm² (AWG 16) and
- 5.2 mm (0.205 in) for conductors up to 4 mm² (AWG 12)

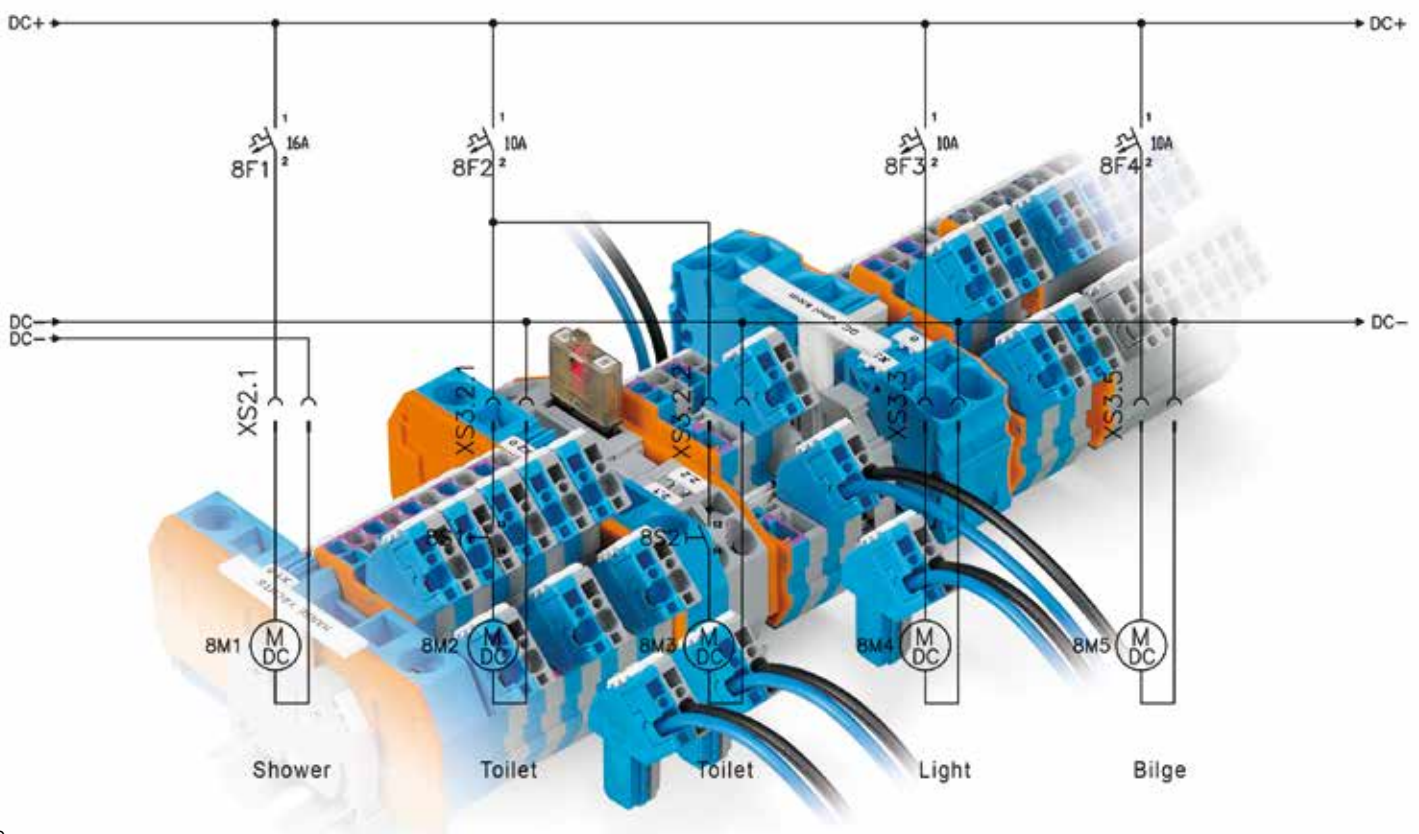

SYSTEM

and Money

Enhanced safety in shipbuilding via:

- Pre-assembly of tested units
- Protection against accidental contact in unmated condition
- Coding provides protection against mismatching
- Allow quick replacement of individual components

3.5 mm (0.138 in) and wider
500 V / 32 A
100 % protected against
mismatching
100 % touch-proof

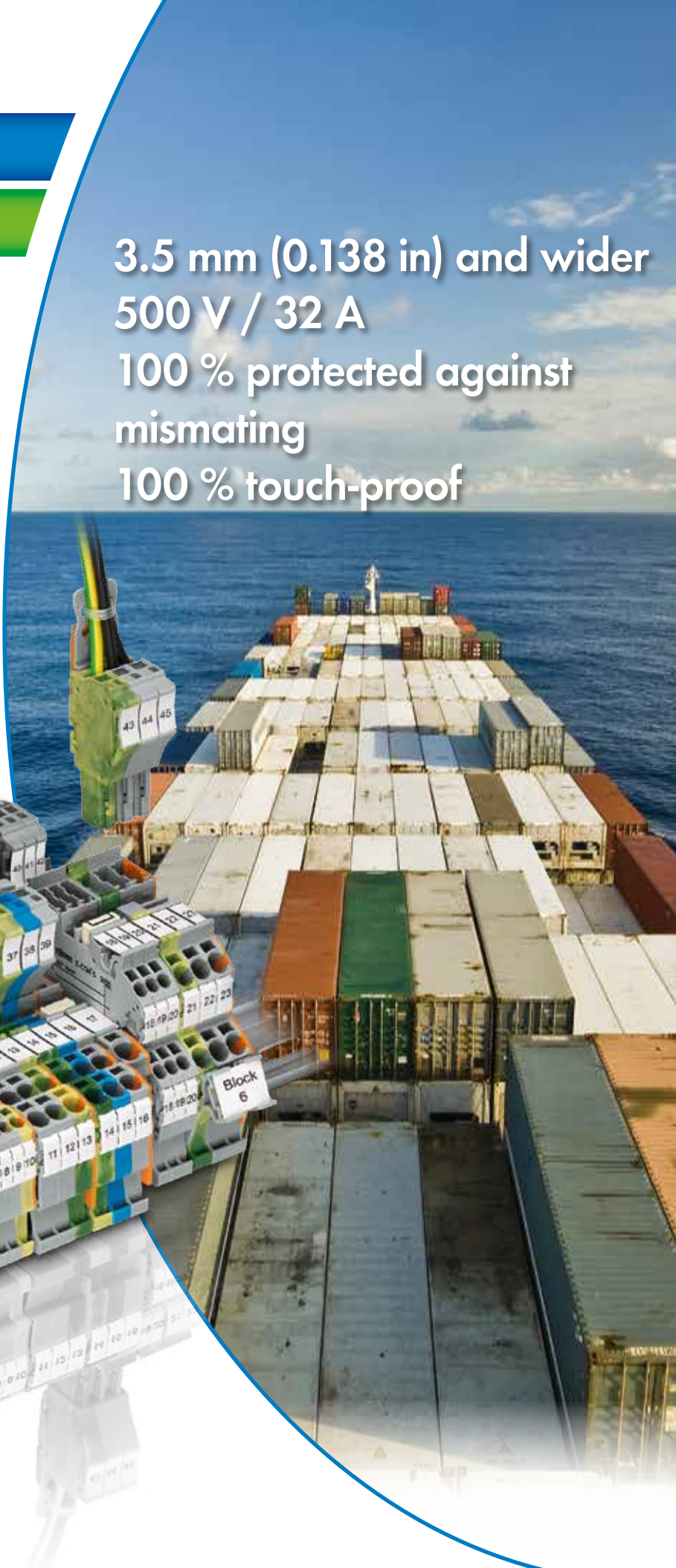
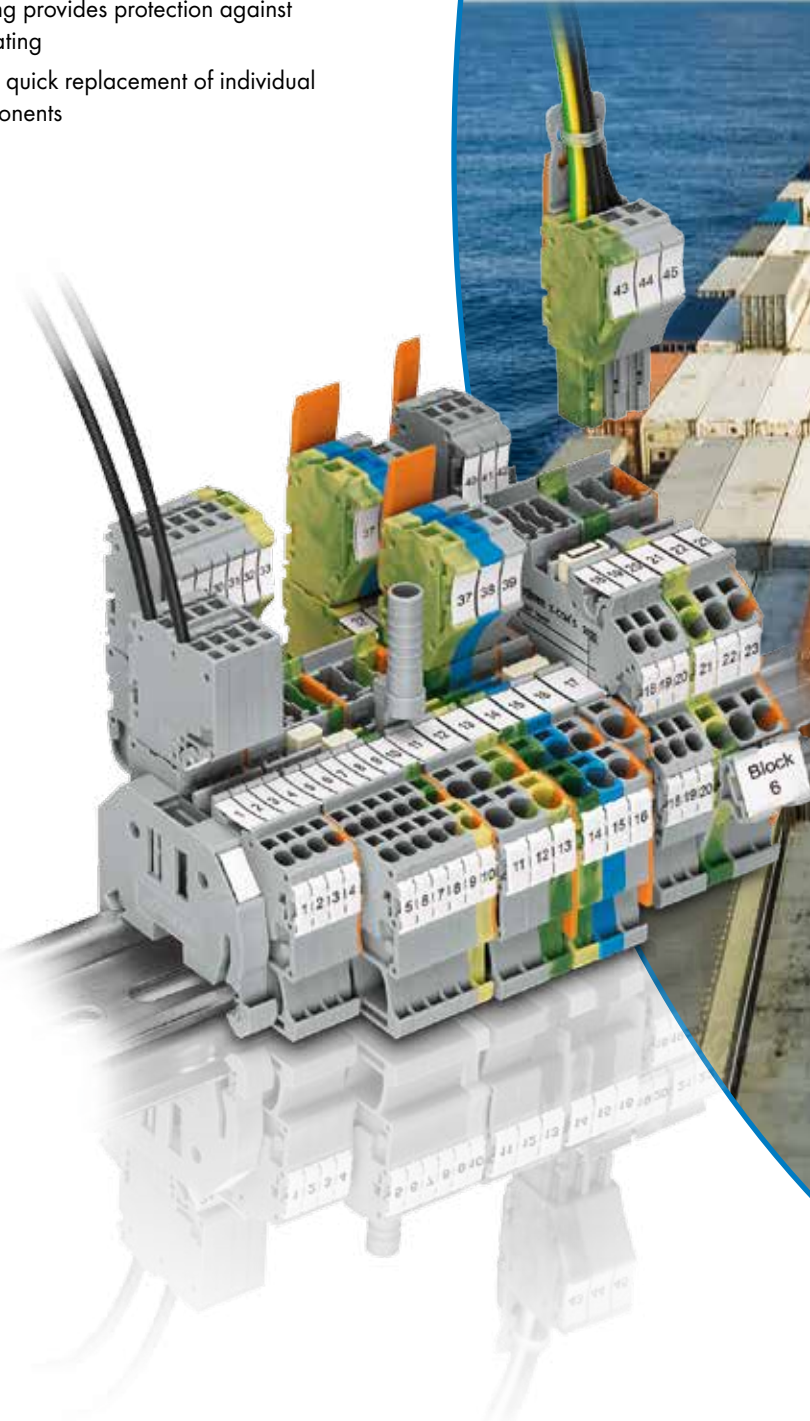



WINSTA® MINI
0.25 to 1.5 mm², 16 A, 400 V

WINSTA® MINI special
0.25 to 1.5 mm², 16 A, 400 V

WINSTA® MIDI
0.5 to 4 mm², 25 A, 400 V

WINSTA® MIDI special
0.5 to 4 mm², 25 A, 400 V

WINSTA® RD
1.5 and 2.5 mm², 16 and 20 A, 250 V

WINSTA® MAXI
0.5 to 6 mm², 35 A, 400 V

WINSTA® IDC
2.5 to 16 mm², 76 A, 400 V

WINSTA® KNX
0.8 mm ø, 3 A, 50 V

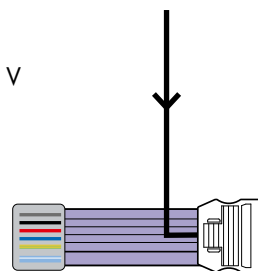

WINSTA® – Pluggable Electrical Installation

for Efficient Series Production

Five Good Reasons to Choose WINSTA®:

- **Quick**
Cable assemblies only have to be plugged in
- **Safety**
Color and physically coded components provide maximum protection against mismatching and help avoid errors
- **Flexible**
Pluggable systems make change of use a snap
- **User-friendly**
Cable assemblies save installers the work of having to connect each separate wire
- **Costs**
Being quicker, safer, more reliable, more flexible and more user-friendly, pluggable electrical systems are the more economical solution



Cabin distribution

WINSTA® – Perfectly Plugged!

WINSTA® is a pluggable connection system that is ideally suited to building system requirements. The system provides the ability to simply plug electrical installations and components together – making install safe, error-free and quick. Using preassembled and quality-tested components (e.g., cable assemblies and distribution boxes), our cutting-edge technology makes installation safer and easier.

Advantages:

- **For planning:**
Modular system for standard applications and custom solutions
- **For installation:**
Minimizing installation times
- **For operation and maintenance:**
Flexible for future changes and expansions

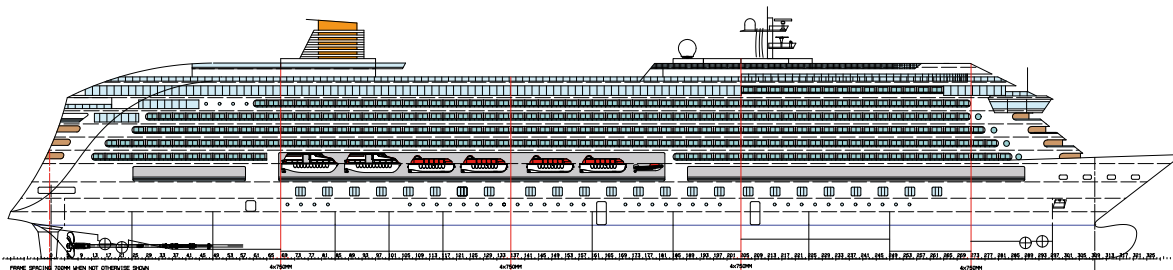

Power supply

Tap-off

Tap-off

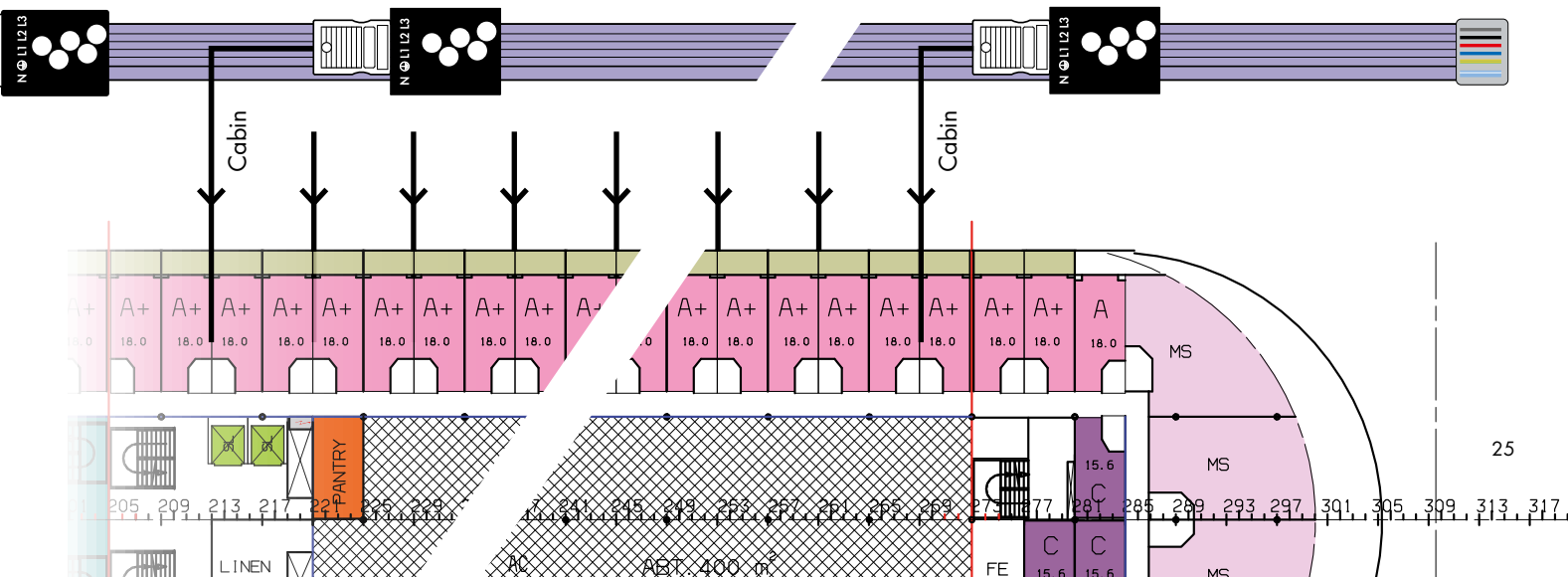

WAGO Product Information

All WAGO products shown in this brochure are available in the following WAGO full line catalogs:

Full Line Catalog, Volume 1 Rail-Mounted Terminal Block Systems

- Rail-Mounted Terminal Blocks
- X-COM®
- Terminal Strips
- Patchboard Systems
- Shield Connecting Systems



Full Line Catalog, Volume 2 PCB Terminal Blocks and Connectors

- PCB Terminal Blocks
- Feedthrough Terminal Blocks
- Pluggable PCB Connectors
- Specialty Connectors



Full Line Catalog, Volume 3 I/O-SYSTEM

- Modular I/O-SYSTEM, IP20/IP67
- Wireless Technology
- AS-Interface - I/O-SYSTEM, IP20/IP67
- Block I/O-SYSTEM, IP67
- Sensor/Actuator Boxes, IP67
- Cables and Connectors, IP67
- Power Supplies



Full Line Catalog, Volume 4 Interface Modules

- Interface Modules, Transmission Modules
- Sensor/Actuator Boxes, IP67
- Wireless Technology
- Overvoltage Protection
- Power Supplies
- Empty Housings and DIN-Rail Mounting Carriers



Full Line Catalog, Volume 5 WINSTA®

- WINSTA® MINI, Pluggable Connectors, Snap-In Connectors
- WINSTA® MIDI, Pluggable Connectors, Snap-In Connectors
- WINSTA® MAXI, Pluggable Connectors
- WINSTA® RD, Cable Assemblies
- WINSTA® KNX, Pluggable Connectors, Snap-In Connectors
- WINSTA® IDC, Supply and Tap-Off Modules for Flat Cables





Marks of approval:

- ABS** (American Bureau of Shipping)
- BV** (Bureau Veritas)
- DNV** (Det Norske Veritas)
- GL** (German Lloyd)

- KR** (Korean Register)
- LR** (Lloyds Register)
- NKK** (Nippon Kaiji Kyokai)
- RINA** (Registro Italiano Navale)
- BSH** (Federal Maritime and Hydrographic Agency)

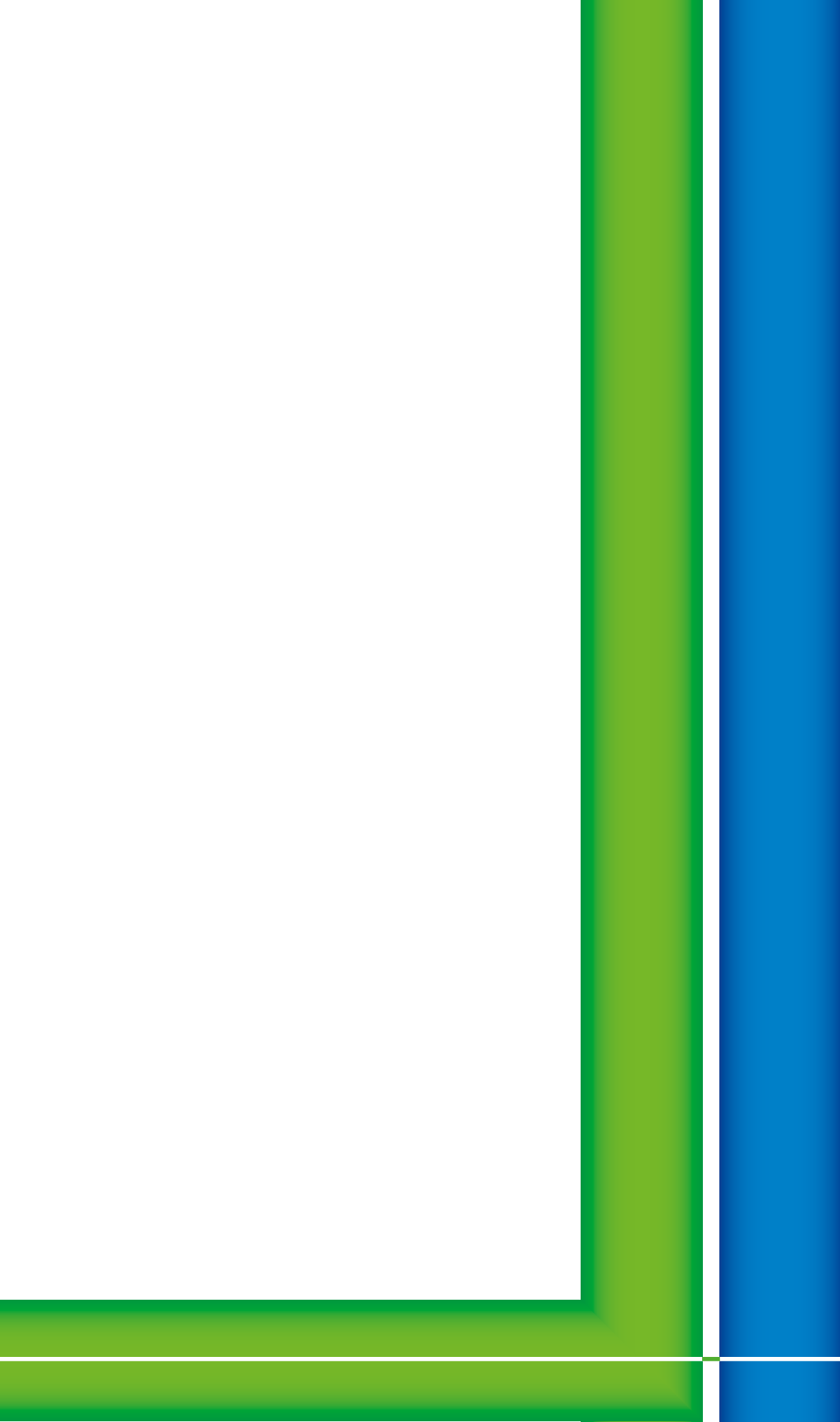

WAGO Kontakttechnik GmbH & Co. KG
Postfach 28 80 · D · 32385 Minden
Hansastraße 27 · D · 32423 Minden
Germany
Phone: +49 571 887-0
Fax: +49 571 887-169
Email: info@wago.com
Online: www.wago.com