



**CONNECT AND PROTECT**

# nVent ERICO Cadweld

Welded Electrical Connections





# Contents

Introduction .....	4	B159VT & B160VT .....	30
Grounding Connection Specification.....	5	B159H & B160H .....	30
The Cadweld Mold Numbering System .....	5	B265 .....	26
<b>CABLE TO CABLE</b>		B321-30 .....	32
PC.....	7	B396 .....	31
PG.....	6, 7, 12, 13	B399AM & B399BM.....	31
PT.....	12	B827A.....	31
SS.....	6	EGRD34.....	31
TA.....	7	EGRD58.....	31
XA.....	10	EST 101.....	34
XB.....	10, 11	EST 201.....	34
<b>CABLE TO GROUND ROD</b>		EST 301.....	34
GR .....	14	ESTREELKIT500.....	34
GT.....	16	G157LT99.....	31
nVent ERICO Cadweld One Shot GR/GT/NT/NX.....	18	L160 & L159.....	30
<b>CABLE TO STEEL SURFACE</b>		Molds.....	24
HA .....	19	Split Crucible Molds.....	29
HS.....	19	T111.....	27
VS.....	20	T304 .....	33
<b>CABLE TO LUG</b>		T305 .....	33
GL.....	21	T306 .....	32
<b>FIELD INFORMATION GUIDE</b> .....	22	T313 .....	26
<b>MATERIALS, TOOLS &amp; ACCESSORIES</b>		T314.....	26
B117A, B, C.....	25	T315A .....	33
B112 .....	25	T319 .....	27
B120 .....	32	T320 .....	32
B133 Series Adapter Sleeves .....	25	T321.....	26
B134 & B135 .....	30	T372A .....	27
B136A .....	28	T328D.....	28
B136B .....	28	T329 .....	33
B137 Series.....	31	T331.....	33
B140A .....	25	T358 .....	27
B141A.....	26	T378L .....	24
B159M.....	31	T393 .....	24
B159V & B160V.....	30	T394 .....	28
		T396 .....	33
		T403 .....	26
		T427.....	25
		Wear Plates.....	29
		Weld Metal.....	24
		XLB974-B2.....	32

# Introduction

This catalog lists the most popular nVent ERICO Cadweld connections using solid or concentric stranded copper conductor, insulated or bare.

If you cannot find the connection you need, contact nVent or your local distributor or agent.

We have designed over 45,000 connections, and "specials" are designed every day.

1. What connection do you want?

We strongly recommend that wherever possible you use molds listed in this catalog or in catalog A1A.

2. Only the most popular nVent ERICO Cadweld connections are listed in this catalog.

For nVent ERICO Cadweld Exolon connections and ordering information, see catalog A1A.

3. What are the conductor sizes?

This catalog covers connections between solid or concentric stranded copper conductors to each other, to lugs, and to ground rods. For sizes not listed, contact your local Cadweld distributor, agent or nVent.

Note: Other publications describe connections to conductors of copper clad, high-voltage copper, aluminum, busbar, lightning protection cable, steel cable, etc.

4. You must have the following to make a weld:

- Mold to fit your conductors
- Weld metal required by your mold
- Handle clamps or frame
- Flint ignitor (included with handle clamps and frames)
- If using nVent ERICO Cadweld Exolon, you need a Relia-Start™ battery instead of a flint ignitor.
- Lugs, sleeves, packing material listed on the page with the mold.

# Grounding Connection Specification

All grounding connections of copper to copper and copper to steel conductors of #8 and larger sized conductors shall be nVent ERICO Cadweld exothermic welded connections. Conductors spliced with a Cadweld exothermic welded connection shall be considered as a continuous conductor, as stated in the notes accompanying NEC 250-50, 250-64, 250-68, 250-70 and IEEE Std 80 – 1986.

All grounding connections to equipment shall use bolted lugs. When the conductor is #8 and larger, the lug shall be joined to the conductor by the Cadweld process, otherwise use listed compression lugs which meet IEEE Std 837 – 1989.

## The Cadweld Mold Numbering System

The Cadweld Mold Part Number gives, in code, the complete information of the mold.

– Type of connection, mold price key, and conductor size(s)

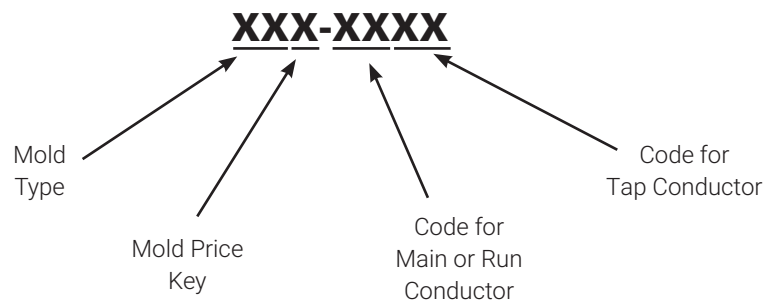

### EXAMPLES

#### **TAD-4L3Q**

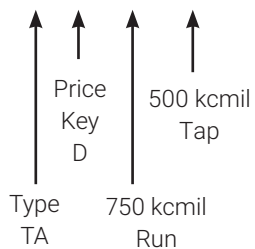

#### **GTC-182V**

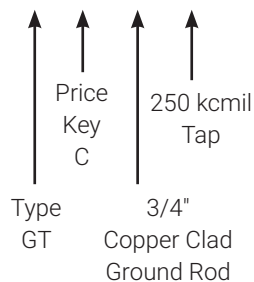

#### **SSC-3D**

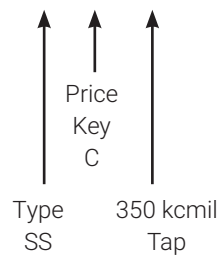

#### **VSC-2C-V3**

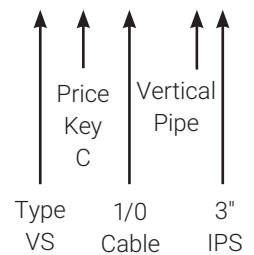

# Horizontal Splice

SS/PG

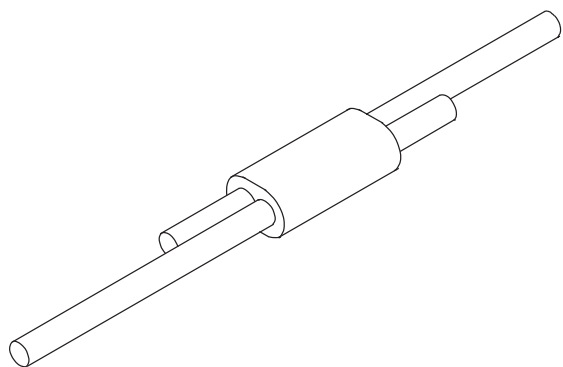
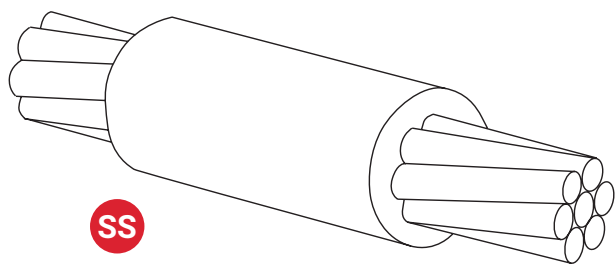

## HORIZONTAL SPLICE

- Splice of horizontal cables.
- Type PG makes a parallel style connection.
- Concentric stranded copper cable unless otherwise noted.
- Solid conductor may be either copper or Copperweld®.
- Also available are splices of different and mixed cable sizes. For Copperweld DSA cables, contact nVent.
- **Bold letter** in mold part number is the price key.

## REQUIRED TOOLS

**Handle Clamps** **L160** for **C** Price Key Molds  
**L159** for **D** Price Key Molds  
 Clamps are included with T Price Key Molds

**Flint Ignitor** **T320** (Included with handle clamp or frame but also available separately)

## SUGGESTED TOOLS

Cable Cleaning Brush	T313 or T314
Slag Removal Spade	B136A or B136B
Mold Cleaning Brush	T394
Cable Clamp	B265
Torch Head	T111

## ACCESSORIES

See Section A

Cable Size	Mold Part No.	Weld Metal
3/0	SSC-2L	90
4/0	SSC-2Q	90
4/0 SOL	SSC-2P	90
250	SSC-2V	115
300	SSC-3A	115
350	SSC-3D	150
500	SSC-3Q	200
750	SSD-4L	2-150
1000	SSD-4Y	2-200

Cable Size	Mold Part No.	Weld Metal
8	PGT-1E1E	15
8 SOL	PGT-1D1D	15
6	PGT-1H1H	25
6 SOL	PGT-1G1G	25
4	SST-1L	25
4 SOL	SST-1K	25
3	SST-1Q	32
2	SST-1V	32
2 SOL	SST-1T	32
1	SST-1Y	32
1 SOL	SST-1X	32
1/0	SSC-2C	45
1/0 SOL	SSC-2B	45
2/0	SSC-2G	65

® Copperweld is a registered trademark of Copperweld Corporation.

# Horizontal Tee

PG/PC/TA

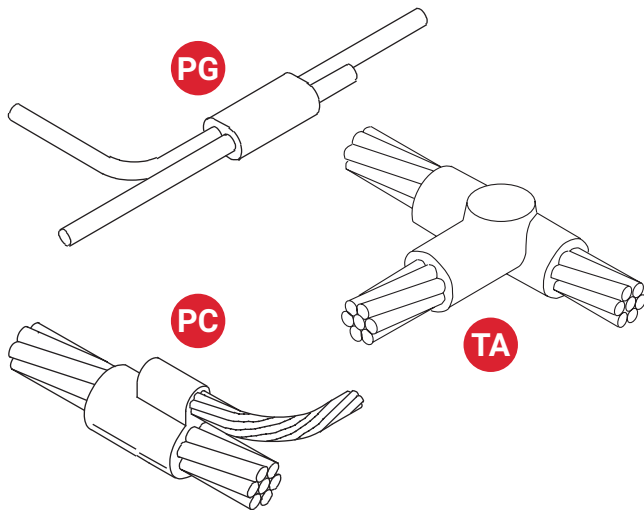

Cable Size		Mold Part No.	Weld Metal	
Run	Tap			
6 SOL	6 SOL	PGT-1G1G	25	
6	6	PGT-1H1H	25	
4	4	TAC-1L1L	32	
	6	PCT-1L1H	32	
	6 SOL	PCT-1L1G	32	
	8	PCT-1L1E	32	
	8 SOL	PCT-1L1D	32	
2 SOL	2	TAC-1T1V	45	
	2 SOL	TAC-1T1T	45	
	4	TAC-1T1L	45	
	6	PCT-1T1H	32	
	6 SOL	PCT-1T1G	32	
	8	PCT-1T1E	32	
	8 SOL	PCT-1T1D	32	
	2	2	TAC-1V1V	45
2 SOL		TAC-1V1T	45	
4		TAC-1V1L	45	
6		PCT-1V1H	32	
6 SOL		PCT-1V1G	32	
8		PCT-1V1E	32	
8 SOL		PCT-1V1D	32	
1		1	TAC-1Y1Y	45
		2	TAC-1Y1V	45
		2 SOL	TAC-1Y1T	45
	4	TAC-1Y1L	45	
	6	PCC-1Y1H	45	
	6 SOL	PCC-1Y1G	45	
	8	PCC-1Y1E	45	
	8 SOL	PCC-1Y1D	45	

## HORIZONTAL TEE CONNECTIONS

- Tee of horizontal run and tap cables.
- PC and PG make parallel style connections which the user can form into a tee.
- Concentric stranded copper cable unless otherwise noted.
- Solid conductor can be either copper or Copperweld®.
- **Bold letter** in mold part number is the price key.

## REQUIRED TOOLS

- Handle Clamps** **L160** for **C** Price Key Molds  
**L159** for **D** Price Key Molds  
 Clamps are included with **T** Price Key Molds
- Flint Ignitor** **T320** (Included with Handle Clamp or frame but also available separately)

## SUGGESTED TOOLS

- Cable Cleaning Brush T313 or T314  
 Slag Removal Spade B136A or B136B  
 Mold Cleaning Brush T394  
 Cable Clamp B265  
 Torch Head T111

## ACCESSORIES

See Section A

Cable Size		Mold Part No.	Weld Metal
Run	Tap		
1/0	1/0	TAC-2C2C	90
	1	TAC-2C1Y	45
	2	TAC-2C1V	45
	2 SOL	TAC-2C1T	45
	4	TAC-2C1L	45
	6	PCC-2C1H	45
	6 SOL	PCC-2C1G	45
	8	PCC-2C1E	45
	8 SOL	PCC-2C1D	45
	2/0	2/0	TAC-2G2G
1/0		TAC-2G2C	90
1		TAC-2G1Y	45
2		TAC-2G1V	45
2 SOL		TAC-2G1T	45
4		TAC-2G1L	45
6		PCC-2G1H	65
6 SOL		PCC-2G1G	65
8		PCC-2G1E	65
8 SOL		PCC-2G1D	65

# Horizontal Tee

## PG/PC/TA

Cable Size	Tap	Mold Part No.	Weld Metal
3/0	3/0	TAC-2L2L	115
	2/0	TAC-2L2G	90
	1/0	TAC-2L2C	90
	1	TAC-2L1Y	45
	2	TAC-2L1V	45
	2 SOL	TAC-2L1T	45
	4	TAC-2L1L	45
	6	PCC-2L1H	90
	6 SOL	PCC-2L1G	90
	8	PCC-2L1E	90
8 SOL	PCC-2L1D	90	
4/0	4/0	TAC-2Q2Q	150
	3/0	TAC-2Q2L	115
	2/0	TAC-2Q2G	90
	1/0	TAC-2Q2C	90
	1	TAC-2Q1Y	90
	2	TAC-2Q1V	90
	2 SOL	TAC-2Q1T	90
	4	TAC-2Q1L	90
	6	PCC-2Q1H	90
	6 SOL	PCC-2Q1G	90
8	PCC-2Q1E	90	
8 SOL	PCC-2Q1D	90	
250	250	TAC-2V2V	150
	4/0	TAC-2V2Q	150
	3/0	TAC-2V2L	150
	2/0	TAC-2V2G	90
	1/0	TAC-2V2C	90
	1	TAC-2V1Y	90
	2	TAC-2V1V	90
	2 SOL	TAC-2V1T	90
	4	TAC-2V1L	90
	300	300	TAC-3A3A
250		TAC-3A2V	150
4/0		TAC-3A2Q	150
3/0		TAC-3A2L	150
2/0		TAC-3A2G	90
1/0		TAC-3A2C	90
1		TAC-3A1Y	90
2		TAC-3A1V	90
2 SOL		TAC-3A1T	90
4		TAC-3A1L	90

Cable Size	Tap	Mold Part No.	Weld Metal
350	350	TAC-3D3D	200
	300	TAC-3D3A	200
	250	TAC-3D2V	200
	4/0	TAC-3D2Q	150
	3/0	TAC-3D2L	150
	2/0	TAC-3D2G	90
	1/0	TAC-3D2C	90
	1	TAC-3D1Y	90
	2	TAC-3D1V	90
	4	TAC-3D1L	90
500	500	TAC-3Q3Q	2-150
	350	TAC-3Q3D	200
	300	TAC-3Q3A	200
	250	TAC-3Q2V	200
	4/0	TAC-3Q2Q	150
	2/0	TAC-3Q2G	90
	1/0	TAC-3Q2C	90
	1	TAC-3Q1Y	90
	2	TAC-3Q1V	90
	4	TAC-3Q1L	90
750	750	TAD-4L4L	500
	500	TAD-4L3Q	2-200
	350	TAC-4L3D	250
	300	TAC-4L3A	200
	250	TAC-4L2V	200
	4/0	TAC-4L2Q	150
	2/0	TAC-4L2G	150
	1/0	TAC-4L2C	150
	1000	TAD-4Y4Y	500
	750	TAD-4Y4L	500
1000	500	TAD-4Y3Q	2-200
	350	TAC-4Y3D	250
	300	TAC-4Y3A	200
	250	TAC-4Y2V	200
	4/0	TAC-4Y2Q	150
	2/0	TAC-4Y2G	150
	1/0	TAC-4Y2C	150



# Horizontal X

## XBQ/XBZ

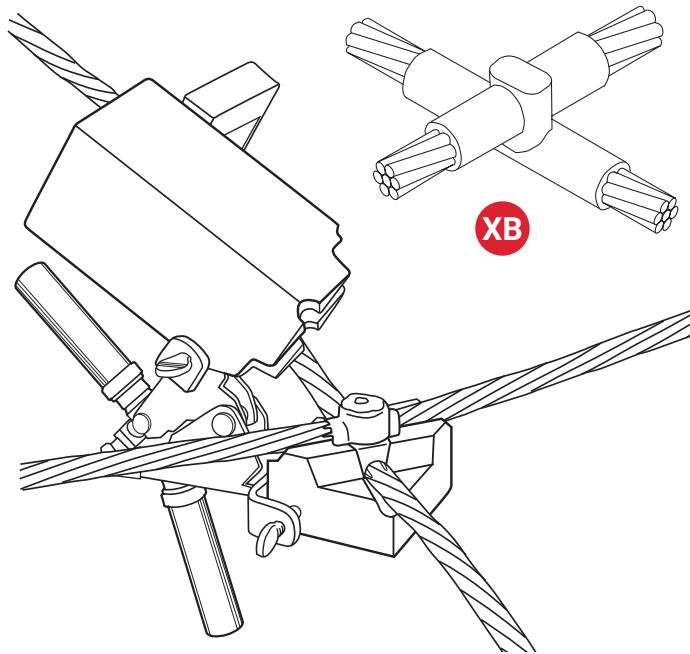

### XBQ/XBZ MOLDS

The Cadweld XB molds are the quickest, most efficient way to make lapped, horizontal x-style connections on solid or concentric stranded cable for a variety of installations.

For cable-to-cable X-style connections at power substations and other commercial and industrial sites, there's never been a faster or easier way to make a reliable Cadweld connection. This two-piece mold lets you make connections in a trench in about half the time it would take with compression connectors or other exothermic products – and at a fraction of the cost.

- Ergonomic two-piece molds use standard L160 and L159 handle clamps...the same clamps you use with other Cadweld molds.
- Saves labor costs. X-style connection can be made by one person in about 1 minute. That's 40 to 70% faster than other methods.
- Costs less. Saves you 1/3 over other models, thanks to innovative design techniques and advanced manufacturing technology.
- Simple to use. Operates just like an XA-style mold, but there's no need to cut the cable!
- Easy cable alignment.
- Also available in "smokeless" Cadweld Exolon.

### NOTES

- Molds not available with wear plates.
- Special cleaning tool supplied with each mold.
- All Q price molds require L160 handle clamp.
- All Z price molds require L159 handle clamp.

### Copper

Cable Size*		Mold	Weld
Run	Tap	Part Number	Metal
1/0 SOL	1/0 SOL	XBQ2B2B	150
1/0 Conc.	1/0 Conc.	XBQ2C2C	150
2/0 SOL	2/0 SOL	XBQ2F2F	200
2/0 Conc.	2/0 Conc.	XBQ2G2G	200
3/0 SOL	3/0 SOL	XBQ2K2K	250
3/0 Conc.	3/0 Conc.	XBQ2L2L	250
4/0 SOL	4/0 SOL	XBQ2P2P	250
4/0 Conc.	4/0 Conc.	XBQ2Q2Q	250
250 SOL	250 SOL	XBQ2T2T	2-150
250 Conc.	250 Conc.	XBQ2V2V	2-150
300 Conc.	300 Conc.	XBZ3A3A	2-200
350 Conc.	350 Conc.	XBZ3D3D	500
400 Conc.	400 Conc.	XBZ3H3H	3-200
500 Conc.	500 Conc.	XBZ3Q3Q	3-250

\* Consult nVent for molds to fit other cable sizes or run/tap combinations.

### COPPERWELD®

Cable Size*		Mold	Weld
Run	Tap	Part Number	Metal
7/#7	7/#7	XBQ9C9C	200
7/#5	7/#5	XBQ9E9E	250
19/#9	19/#9	XBQ9F9F	2-150
19/#8	19/#8	XBZ9G9G	2-200
19/#7	19/#7	XBZ9H9H	500
19/#6	19/#6	XBZ9J9J	3-250

\* Consult nVent for molds to fit other cable sizes or run/tap combinations.

# Horizontal X

## XA/XB

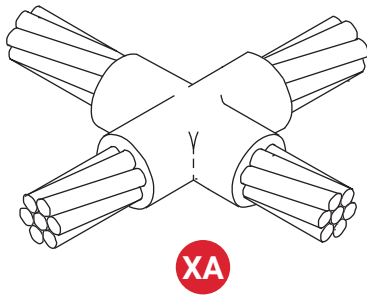

**XA**

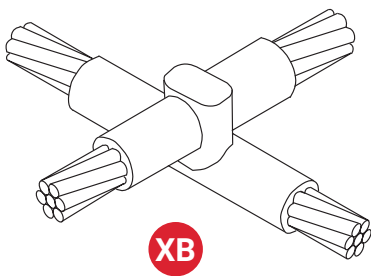

**XB**

### HORIZONTAL X CONNECTIONS

- XA – Cross of horizontal cables, tap cable cut –cables in same plane.
- XB – Cross of horizontal cables, lapped and not cut.
- Concentric stranded copper cable unless otherwise noted.
- Solid conductor may be either copper or Copperweld®.
- **Bold letter** in mold part number is the price key.

### REQUIRED TOOLS

**Handle Clamps** **L160** for **C** and **Q** Price Key Molds  
**L159** for **D** and **Z** Price Key Molds  
 Clamps are included with M, P, and V Price Key Molds

**Flint Ignitor** **T320** (Included with Handle Clamp or frame but also available separately)

### SUGGESTED TOOLS

Cable Cleaning Brush	T313 or T314
Slag Removal Spade	B136A, B136B, or B136C
Mold Cleaning Brush	T394
Cable Clamp	B265
Torch Head	T111

### ACCESSORIES

See Section A

Cable Size		Type XA		Type XB	
Run	Tap	Mold Part No.	Weld Metal	Mold Part No.	Weld Metal
6 SOL	6 SOL	USE XB	–	XBP-1G1G	32
6	6	USE XB	–	XBP-1H1H	45
4	4	XAC-1L1L	45	XBC-1L1L	65
2	2	XAC-1V1V	65	XBC-1V1V	90
	4	XAC-1V1L	65	XBC-1V1L	65
	2 SOL	XAC-1T1T	65	XBC-1T1T	90
1	1	XAC-1Y1Y	65	XBC-1Y1Y	115
	2	XAC-1Y1V	65	XBC-1Y1V	90
	4	XAC-1Y1L	65	XBC-1Y1L	90
	1/0	XAC-2C2C	90	XBM-2C2C	150
1/0	1	XAC-2C1Y	90	XBM-2C1Y	150
	2	XAC-2C1V	90	XBM-2C1V	115
	4	XAC-2C1L	90	XBM-2C1L	115
	2/0	XAC-2G2G	115	XBM-2G2G	200
2/0	1/0	XAC-2G2C	115	XBM-2G2C	200
	1	XAC-2G1Y	115	XBM-2G1Y	150
	2	XAC-2G1V	115	XBM-2G1V	150

# Horizontal X

## XA/XB

Cable Size		Type XA		Type XB	
Run	Tap	Mold Part No.	Weld Metal	Mold Part No.	Weld Metal
3/0	3/0	XAC-2L2L	150	XBM-2L2L	250
	2/0	XAC-2L2G	150	XBM-2L2G	200
	1/0	XAC-2L2C	115	XBM-2L2C	200
	1	XAC-2L1Y	115	XBM-2L1Y	150
	2	XAC-2L1V	115	XBM-2L1V	150
4/0	4/0	XAC-2Q2Q	200	XBM-2Q2Q	250
	3/0	XAC-2Q2L	200	XBM-2Q2L	250
	2/0	XAC-2Q2G	150	XBM-2Q2G	200
	1/0	XAC-2Q2C	150	XBM-2Q2C	200
	1	XAC-2Q1Y	115	XBM-2Q1Y	150
250	2	XAC-2Q1V	115	XBM-2Q1V	150
	250	XAC-2V2V	200	XBM-2V2V	2-150
	4/0	XAC-2V2Q	200	XBM-2V2Q	2-150
	3/0	XAC-2V2L	200	XBM-2V2L	2-150
	2/0	XAC-2V2G	150	XBM-2V2G	250
	1/0	XAC-2V2C	150	XBM-2V2C	250
	1	XAC-2V1Y	115	XBM-2V1Y	200
300	2	XAC-2V1V	115	XBM-2V1V	150
	300	XAC-3A3A	250	XBV-3A3A	2-200
	250	XAC-3A2V	250	XBV-3A2V	2-200
	4/0	XAC-3A2Q	200	XBM-3A2Q	2-150
	3/0	XAC-3A2L	200	XBM-3A2L	2-150
	2/0	XAC-3A2G	150	XBM-3A2G	250
	1/0	XAC-3A2C	150	XBM-3A2C	250
	1	XAC-3A1Y	115	XBM-3A1Y	200
350	2	XAC-3A1V	115	XBM-3A1V	150
	350	XAC-3D3D	250	XBV-3D3D	500
	300	XAC-3D3A	250	XBV-3D3A	500
	250	XAC-3D2V	250	XBV-3D2V	500
	4/0	XAC-3D2Q	200	XBV-3D2Q	2-200
	3/0	XAC-3D2L	200	XBV-3D2L	2-200
	2/0	XAC-3D2G	200	XBM-3D2G	2-150
	1/0	XAC-3D2C	200	XBM-3D2C	250
	1	XAC-3D1Y	150	XBM-3D1Y	200
500	2	XAC-3D1V	150	XBM-3D1V	200
	500	XAD-3Q3Q	500	XBV-3Q3Q	3-250
	350	XAD-3Q3D	2-200	XBV-3Q3D	3-200
	300	XAD-3Q3A	2-200	XBV-3Q3A	3-200
	250	XAD-3Q2V	2-150	XBV-3Q2V	500
	4/0	XAD-3Q2Q	2-150	XBV-3Q2Q	500
	3/0	XAD-3Q2L	2-150	XBV-3Q2L	500
	2/0	XAC-3Q2G	250	XBV-3Q2G	2-200
1/0	XAC-3Q2C	250	XBM-3Q2C	2-150	

# Parallel Horizontal

## PG/PT

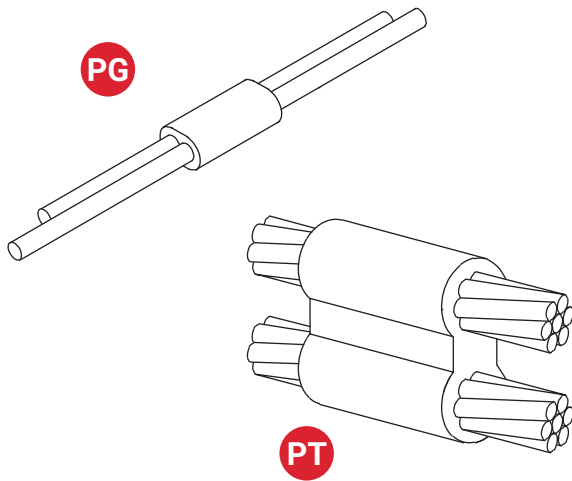

Cable Size Run	Tap	Mold Part No.	Weld Metal
6 SOL	6 SOL	PGT-1G1G	25
6	6	PGT-1H1H	25
	4	PTC-1L1L	32
	6	PTC-1L1H	32
4	6 SOL	PTC-1L1G	32
	8	PTC-1L1E	32
	8 SOL	PTC-1L1D	32
2 SOL	2	PTC-1T1V	65
	2 SOL	PTC-1T1T	65
	4	PTC-1T1L	65
	6	PTC-1T1H	45
	6 SOL	PTC-1T1G	45
	8	PTC-1T1E	45
	8 SOL	PTC-1T1D	45
2	2	PTC-1V1V	65
	4	PTC-1V1L	65
	6	PTC-1V1H	45
	6 SOL	PTC-1V1G	45
2	8	PTC-1V1E	45
	8 SOL	PTC-1V1D	45
	8 SOL	PTC-1V1D	45
1 SOL	1	PTC-1X1Y	65
	2	PTC-1X1V	65
	2 SOL	PTC-1X1T	65
	4	PTC-1X1L	65
	6	PTC-1X1H	65
	6 SOL	PTC-1X1G	65
	8	PTC-1X1E	45
	8 SOL	PTC-1X1D	45

### PARALLEL HORIZONTAL CONDUCTORS

- Parallel through connection of horizontal cables.
- Run conductor is on the bottom of Type PT molds.
- Concentric stranded copper cable unless otherwise noted.
- Solid conductor may be either copper or Copperweld®.
- **Bold letter** in mold part number is the price key.

### REQUIRED TOOLS

- Handle Clamps** **L160** for **C** Price Key Molds  
Clamps are included with **T** Price Key Molds
- Flint Ignitor** **T320** (Included with Handle Clamp or frame but also available separately)

### SUGGESTED TOOLS

- Cable Cleaning Brush T313 or T314  
Slag Removal Spade B136A or B136B  
Mold Cleaning Brush T394  
Cable Clamp B265  
Torch Head T111

### ACCESSORIES

See Section A

Cable Size Run	Tap	Mold Part No.	Weld Metal
1	1	PTC-1Y1Y	65
	1 SOL	PTC-1Y1X	65
	2	PTC-1Y1V	65
	2 SOL	PTC-1Y1T	65
	4	PTC-1Y1L	65
	6	PTC-1Y1H	65
	6 SOL	PTC-1Y1G	65
	8	PTC-1Y1E	45
	8 SOL	PTC-1Y1D	45
	1/0 SOL	1/0	PTC-2B2C
1/0 SOL		PTC-2B2B	90
1		PTC-2B1Y	65
1 SOL		PTC-2B1X	65
2		PTC-2B1V	65
2 SOL		PTC-2B1T	65
4		PTC-2B1L	65
6		PTC-2B1H	65
6 SOL		PTC-2B1G	65
8		PTC-2B1E	65
8 SOL	PTC-2B1D	65	

# Parallel Horizontal

## PG/PT

Cable Size	Mold	Weld	
Run	Tap	Part No.	Metal
1/0	1/0	PTC-2C2C	90
	1/0 SOL	PTC-2C2B	90
	1	PTC-2C1Y	65
	1 SOL	PTC-2C1T	65
	2	PTC-2C1V	65
	2 SOL	PTC-2C1T	65
	4	PTC-2C1L	65
	6	PTC-2C1H	65
	6 SOL	PTC-2C1G	65
	8	PTC-2C1E	65
8 SOL	PTC-2C1D	65	
2/0	2/0	PTC-2G2G	115
	1/0	PTC-2G2C	115
	1/0 SOL	PTC-2G2B	115
	2	PTC-2G1V	90
	1	PTC-2G1Y	90
	1 SOL	PTC-2G1X	90
	4	PTC-2G1L	90
	6	PTC-2G1H	90
	6 SOL	PTC-2G1G	90
	8	PTC-2G1E	65
8 SOL	PTC-2G1D	65	
3/0	3/0	PTC-2L2L	150
	2/0	PTC-2L2G	150
	1/0	PTC-2L2C	115
	1/0 SOL	PTC-2L2B	115
	2	PTC-2L1V	115
	2 SOL	PTC-2L1T	115
	1 SOL	PTC-2L1X	115
	1	PTC-2L1Y	115
	4	PTC-2L1L	115
	6	PTC-2L1H	90
6 SOL	PTC-2L1G	90	
8	PTC-2L1E	90	
8 SOL	PTC-2L1D	90	

Cable Size	Mold	Weld	
Run	Tap	Part No.	Metal
4/0	4/0	PTC-2P2Q	200
	4/0 SOL	PTC-2P2P	200
	3/0	PTC-2P2L	200
	2/0	PTC-2P2G	150
	1/0	PTC-2P2C	150
	1/0 SOL	PTC-2P2B	150
	1	PTC-2P1Y	150
	1 SOL	PTC-2P1X	150
	2	PTC-2P1V	150
	2 SOL	PTC-2P1T	150
4/0	4	PTC-2P1L	150
	6	PTC-2P1H	90
	6 SOL	PTC-2P1G	90
	8	PTC-2P1E	90
	8 SOL	PTC-2P1D	90
	4/0	PTC-2Q2Q	200
	4/0 SOL	PTC-2Q2P	200
	3/0	PTC-2Q2L	200
	2/0	PTC-2Q2G	150
	1/0	PTC-2Q2C	150
1/0 SOL	PTC-2Q2B	150	
4/0	1	PTC-2Q1V	150
	1 SOL	PTC-2Q1X	150
	2	PTC-2Q1V	150
	2 SOL	PTC-2Q1T	150
	4	PTC-2Q1L	150
	6	PTC-2Q1H	90
	6 SOL	PTC-2Q1G	90
	8	PTC-2Q1E	90
	8 SOL	PTC-2Q1D	90



CONDUCTOR SIZE		Cadweld One Shot Part No.
Solid	Stranded	Parallel Tap
3, 4	4, 6	PG11L

The nVent ERICO Cadweld One Shot case is a ceramic disposable body replacing the familiar semi-permanent graphite mold and associated handle clamp. Everything required is included except the flint ignitor.

NEC Compliant, UL Listed

# Cable To Ground Rod

GR

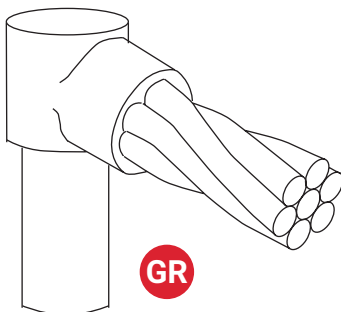

## CABLE TO GROUND ROD

- Parallel t.
- Single cable to top of ground rod. Concentric strand copper cable unless otherwise noted. For copper clad, galvanized, stainless clad or stainless steel ground rods.
- Bold letter in mold part number is the price key.

## REQUIRED TOOLS

**Handle Clamps** **L160** for **C** Price Key Molds  
Clamps are included with T Price Key Molds

**Flint Ignitor** **T320** (Included with Handle Clamp or frame but also available separately)

## SUGGESTED TOOLS

Cable Cle65  
Torch Head T111

## ACCESSORIES

See Section A

Ground Rod Size	Cable Size	Mold Part Number			
		Steel	Copper Clad Plain (Unthreaded)	Copper Clad Sectional (With 9/16" Threads)	Weld Metal
1/2"	6	GRT-14C1H	GRT-14A1H	GRT-14B1H	25
	6 SOL	GRT-14C1G	GRT-14A1G	GRT-14B1G	25
	4	GRT-14C1L	GRT-14A1L	GRT-14B1L	25
	4 SOL	GRT-14C1K	GRT-14A1K	GRT-14B1K	25

Ground Rod Size	Cable Size	Steel Or Copper Clad Sectional (With 9/16" Threads)	Copper Clad Plain (Unthreaded)	Copper Clad Sectional (With 1/2" Threads)	Weld Metal
1/2"	2	GRC-141V	GRC-151V	GRC-131V	65
	1	GRC-141Y	GRC-151Y	GRC-131Y	65
	1/0	GRC-142C	GRC-152C	GRC-132C	90
	1/0 SOL	GRC-142B	GRC-152B	GRC-132B	90
	2/0	GRC-142G	GRC-152G	GRC-132G	90
	3/0	GRC-142L	GRC-152L	GRC-132L	90
	4/0	GRC-142Q	GRC-152Q	GRC-132Q	90
	250	GRC-142V	GRC-152V	GRC-132V	90
	300	GRC-143A	GRC-153A	GRC-133A	90

# Cable To Ground Rod

## GR

Ground Rod Size	Cable Size	Mold Part Number		
		Copper Clad Plain (Unthreaded)	Steel Or Copper Clad Sectional (Threaded)	Weld Metal
5/8"	6	GRT-161H	GRT-311H	32
	6 SOL	GRT-161G	GRT-311G	32
	4	GRT-161L	GRT-311L	32
	4 SOL	GRT-161K	GRT-311K	32

Ground Rod Size	Cable Size	Copper Clad Sectional (threaded) or Plain		
		Copper Clad Sectional (threaded) or Plain	Steel	Weld Metal
5/8"	2	GRC-161V	GRC-311V	65
	1	GRC-161Y	GRC-311Y	65
	1/0	GRC-162C	GRC-312C	90
	1/0 SOL	GRC-162B	GRC-312B	90
	2/0	GRC-162G	GRC-312G	90
	3/0	GRC-162L	GRC-312L	90
	4/0	GRC-162Q	GRC-312Q	90
	250	GRC-162V	GRC-312V	90
	300	GRC-163A	GRC-313A	115
	350	GRC-163D	GRC-313D	115
	500	GRC-163Q	GRC-313Q	150

Ground Rod Size	Cable Size	Copper Clad Plain (unthreaded)		
		Copper Clad Plain (unthreaded)	Steel or Copper Clad Sectional (threaded)	Weld Metal
3/4"	6	GRT-181H	GRT-331H	32
	6SOL	GRT-181G	GRT-331G	32
	4	GRP-181L	GRP-331L	45
	4 SOL	GRP-181K	GRP-331K	45

Ground Rod Size	Cable Size	Copper Clad Sectional (threaded) or Plain		
		Copper Clad Sectional (threaded) or Plain	Steel	Weld Metal
3/4"	2	GRC-181V	GRC-331V	90
	1	GRC-181Y	GRC-331Y	90
	1/0	GRC-182C	GRC-332C	90
	1/0 SOL	GRC-182B	GRC-332B	90
	2/0	GRC-182G	GRC-332G	90
	3/0	GRC-182L	GRC-332L	90
	4/0	GRC-182Q	GRC-332Q	90
	250	GRC-182V	GRC-332V	90
	300	GRC-183A	GRC-333A	115
	350	GRC-183D	GRC-333D	115
	500	GRC-183Q	GRC-333Q	150

1" Contact nVent for ordering information

# Cable To Ground Rod

GT

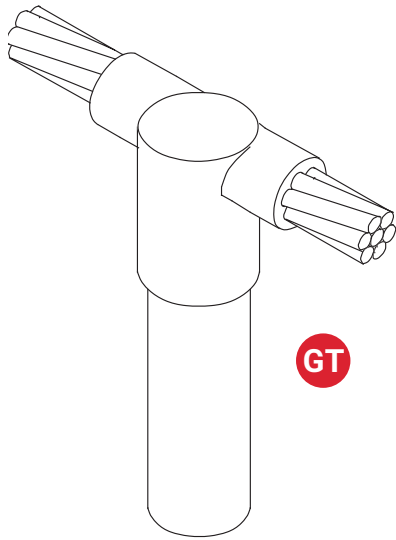

## THROUGH CABLE TO GROUND ROD

- Through cable to top of ground rod. Connections are for concentric strand copper cable unless otherwise noted. For copper clad, galvanized, stainless clad or stainless steel ground rods.
- **Bold letter** in mold part number is the price key.

## REQUIRED TOOLS

- Handle Clamps** **L160** for C Price Key Molds  
Clamps are included with T or P Price Key Molds
- Flint Ignitor** **T320** (Included with Handle Clamp or frame but also available separately)

## SUGGESTED TOOLS

- |                      |                |
|----------------------|----------------|
| Cable Cleaning Brush | T313 or T314   |
| Slag Removal Spade   | B136A or B136B |
| Mold Cleaning Brush  | T394           |
| File                 | T329           |
| Torch Head           | T111           |

## ACCESSORIES

See Section A

Ground Rod Size	Cable Size	Mold Part Number			Weld Metal
		Steel	Copper Clad Plain (Unthreaded)	Copper Clad Sectional (With 9/16" Threads)	
1/2"	6	GTT-14C1H	GTT-14A1H	GTT-14B1H	32
	6 SOL	GTT-14C1G	GTT-14A1G	GTT-14B1G	32
	4	GTT-14C1L	GTT-14A1L	GTT-14B1L	32
	4 SOL	GTT-14C1K	GTT-14A1K	GTT-14B1K	32

Ground Rod Size	Cable Size	Steel or Copper Clad Sectional (with 9/16" threads)	Copper Clad Plain (unthreaded)	Copper Clad Sectional (with 1/2" threads)	Weld Metal
		2	GTC-141V	GTC-151V	
1/2"	1	GTC-141Y	GTC-151Y	GTC-131Y	90
	1/0	GTC-142C	GTC-152C	GTC-132C	90
	1/0 SOL	GTC-142B	GTC-152B	GTC-132B	90
	2/0	GTC-142G	GTC-152G	GTC-132G	90
	3/0	GTC-142L	GTC-152L	GTC-132L	115
	4/0	GTC-142Q	GTC-152Q	GTC-132Q	115
	250	GTC-142V	GTC-152V	GTC-132V	150
	300	GTC-143A	GTC-153A	GTC-133A	200



# Cable To Ground Rod

GT

Ground Rod Size	Cable Size	Mold Part Number		
		Copper Clad Plain (Unthreaded)	Steel Or Copper Clad Sectional (Threaded)	Weld Metal
5/8"	6	GTT-161H	GTT-311H	32
	6 SOL	GTT-161G	GTT-311G	32
	4	GTT-161L	GTT-311L	32
	4 SOL	GTT-161K	GTT-311K	32

		Copper Clad Sectional (threaded) or Plain		
		Copper Clad Sectional (threaded) or Plain	Steel	
5/8"	2	GTC-161V	GTC-311V	90
	1	GTC-161Y	GTC-311Y	90
	1/0	GTC-162C	GTC-312C	90
	1/0 SOL	GTC-162B	GTC-312B	115
	2/0	GTC-162G	GTC-312G	115
	3/0	GTC-162L	GTC-312L	115
	4/0	GTC-162Q	GTC-312Q	115
	250	GTC-162V	GTC-312V	150
	300	GTC-163A	GTC-313A	200
	350	GTC-163D	GTC-313D	200
	500	GTC-163Q	GTC-313Q	250

		Copper Clad Plain (unthreaded)		
		Copper Clad Plain (unthreaded)	Steel or Copper Clad Sectional (threaded)	
3/4"	6	GTP-181H	GTP-331H	45
	6 SOL	GTP-181G	GTP-331G	45
	4	GTP-181L	GTP-331L	65
	4 SOL	GTP-181K	GTP-331K	65

		Copper Clad Sectional (threaded) or Plain		
		Copper Clad Sectional (threaded) or Plain	Steel	
3/4"	2	GTC-181V	GTC-331V	90
	1	GTC-181Y	GTC-331Y	90
	1/0	GTC-182C	GTC-332C	115
	1/0 SOL	GTC-182B	GTC-332B	115
	2/0	GTC-182G	GTC-332G	115
	3/0	GTC-182L	GTC-332L	115
	4/0	GTC-182Q	GTC-332Q	115
	250	GTC-182V	GTC-332V	150
	300	GTC-183A	GTC-333A	200
	350	GTC-183D	GTC-333D	200
	500	GTC-183Q	GTC-333Q	250

1" Contact nVent for ordering information

# Cadweld One Shot Cable To Ground Rod

GR/GT/NT/NX

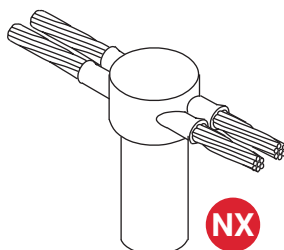
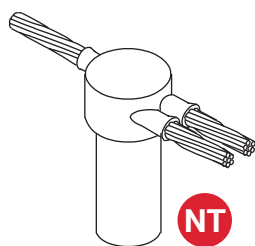
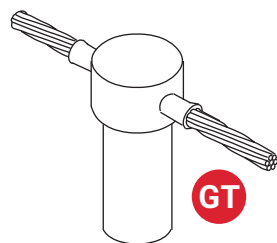
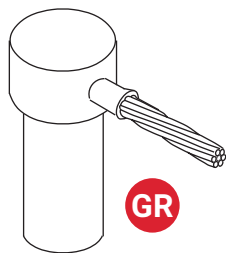

## CABLE TO GROUND ROD USING CADWELD ONE SHOT CONNECTIONS

For plain or threaded copper clad and galvanized steel or stainless steel rods. The Cadweld One Shot case is a ceramic disposable body replacing the familiar semi-permanent graphite mold and associated Handle Clamp. Everything required is included except the flint ignitor.

R.E.A. Accepted

NEC Approved

UL Listed

## REQUIRED TOOLS

Flint Ignitor T320

## SUGGESTED TOOLS

Cable Cleaning Brush T313 or T314  
 File T329  
 Torch Head T111

## ACCESSORIES

See Section A

Cadweld One Shot connections are available in standard packages of 12 each.

Ground Rod Size	Conductor		Connector Part Number			
	Solid	Stranded	Type GR	Type GT	Type NT	Type NX
1/2"	6,8	8	GR1-141G	GT1-141G	NT1-141G	NX1-141G
	3,4	4,6	GR1-141L	GT1-141L	NT1-141L	NX1-141L
	1,2	2,3	GR1-141V	GT1-141V	NT1-141V	—
5/8"	6,8	8	GR1-161G	GT1-161G	NT1-161G	NX1-161G
	3,4	4,6	GR1-161L	GT1-161L	NT1-161L	NX1-161L
	1,2	2,3	GR1-161V	GT1-161V	NT1-161V	NX1-161V
	2/0, 1/0	1/0, 1	GR1-162C	GT1-162C	—	—
		2/0	GR1-162G	GT1-162G	—	—
4/0	GR1-162Q	—	—	—	—	
3/4"	6,8	8	GR1-181G	GT1-181G	NT1-181G	NX1-181G
	3,4	4,6	GR1-181L	GT1-181L	NT1-181L	NX1-181L
	1,2	2,3	GR1-181V	GT1-181V	NT1-181V	NX1-181V
	2/0, 1/0	1/0, 1	GR1-182C	GT1-182C	—	—
		2/0	GR1-182G	GT1-182G	—	—
		4/0	GR1-182Q	—	—	—

# Horizontal Steel Surface

## HA/HS

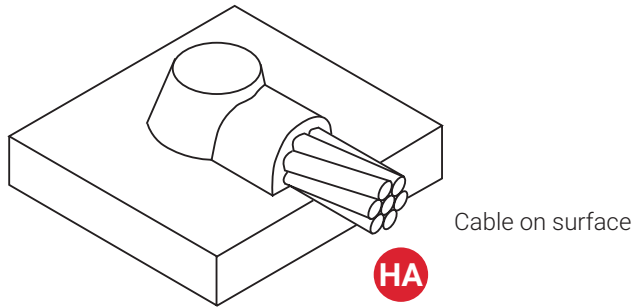

Cable on surface

HA

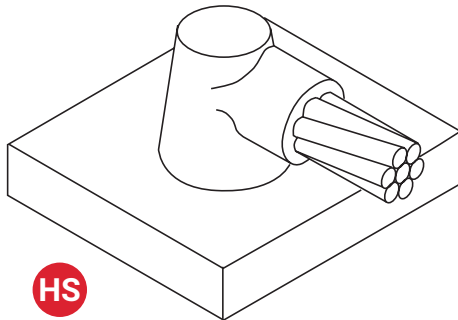

Cable off surface

HS

HA\*\*

Cable Size	Mold Part No.	Weld Metal
6*	HAA-1H	45
4	HAA-1L	45
2	HAA-1V	45
1	HAA-1Y	65

\*\*Mold Sealer T403 (Required for HA type molds)

HS

Cable Size	Mold Part No.	Weld Metal
1/0	HSC-2C	90
2/0	HSC-2G	90
3/0	HSC-2L	115
4/0	HSC-2Q	115
250	HSC-2V	115
300	HSC-3A	150
350	HSC-3D	200
500	HSC-3Q	200
750	HSD-4L	2-150
1000	HSD-4Y	2-200

\*Requires B-112 sleeve (1 per weld)

### THROUGH CABLE TO GROUND ROD

- Horizontal concentric copper conductor to flat steel surface or top of horizontal pipe
- Cadweld also has a complete product line for cathodic protection connections. See Bulletin CA1A.
- **A test weld should be made to check the possibility of burn through on thin sections or thin wall pipe.**
- Concentric stranded copper cable listed.
- **Bold letter** in mold part number is the price key.

### REQUIRED TOOLS

**Handle Clamps** **L160** for **C** Price Key Molds  
**L159** for **D** Price Key Molds  
 Handle is included with **A** Price Key Molds

**Flint Ignitor** **T320** (Included with Handle Clamp or frame but also available separately)

**Mold Sealer\*\*** **T403** (Required for HA type molds)

### SUGGESTED TOOLS

Cable Cleaning Brush T313 or T314  
 Slag Removal Spade B136A or B136B  
 Mold Cleaning Brush T394  
 Cable Clamp B265  
 Torch Head T111

### ACCESSORIES

See Section A

Cable to Steel Pipe (Types **HA** and **HS**) – Use flat surface mold part number with suffix.

Cable	Nominal Pipe Size	Suffix
#1 and smaller	12" and smaller	Nominal Pipe Size
	14" and larger	None
1/0 thru 250	28" and smaller	Nominal Pipe Size
	30" and larger	None"

Example: #1 cable to 3-1/2" pipe, HAA-1Y-3.50

For welds to copper surface, see section 5 of catalog A1A

# Vertical Steel Surface

VS

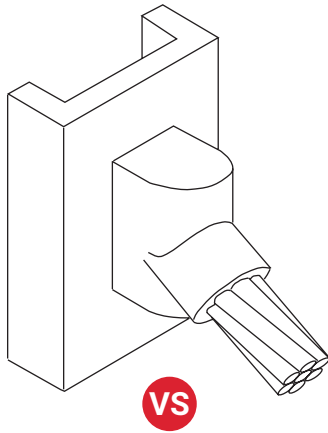

## VERTICAL STEEL SURFACE

- Cable down at 45° to vertical steel surface including pipe.
- Cable to vertical flat steel surface; cable to side of vertical or horizontal steel pipe.
- Cadweld also has a complete product line for cathodic protection connections. See Bulletin CA1A.
- Concentric stranded copper cable listed.
- **A test weld should be made to check the possibility of burn through on thin sections or thin wall pipe.**
- **Bold letter** in mold part number is the price key.

## REQUIRED TOOLS

**Handle Clamps** **L160** for **C** Price Key Molds  
**L159** for **D** Price Key Moldss

**Flint Ignitor** **T320** (Included with Handle Clamp but also available separately)

## SUGGESTED TOOLS

Cable Cleaning Brush	T313 or T314
Slag Removal Spade	B136A or B136B
Mold Cleaning Brush	T394
Cable Clamp	B265
Torch Head	T111

## ACCESSORIES

See Section A

Cable to Vertical Steel Pipe –  
Use flat surface mold part number; add V and suffix.

Cable	Nominal Pipe Size	Suffix
#6 thru 250	30" and smaller	Nominal Pipe Size
	32" and larger	None

Example: 4/0 to 4" pipe, VSC-2Q-V4

Cable to horizontal steel pipe –  
Add **H** and nominal pipe size to flat surface mold number.  
Example: 2/0 to 8" pipe, VSC-2G-H8"

Cable Size	Mold Part No.	Weld Metal
6*	VSC-1H	45
4	VSC-1L	45
2	VSC-1V	45
1	VSC-1Y	65
1/0	VSC-2C	90
2/0	VSC-2G	90
3/0	VSC-2L	115
4/0	VSC-2Q	115
250	VSC-2V	115
300	VSC-3A	150
350	VSC-3D	200
500	VSC-3Q	200
750	VSD-4L	2-150
1000	VSD-4Y	2-200

\*Requires B-112 sleeve (1 per weld)

# Copper Lugs

GL

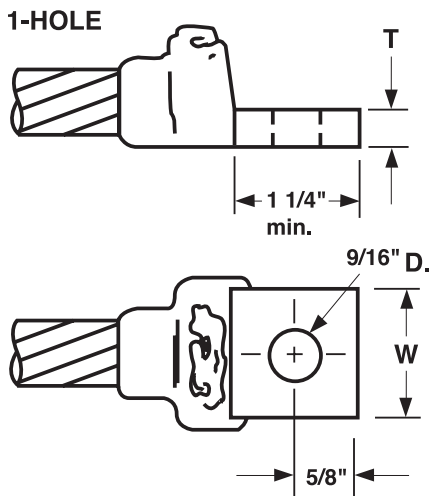
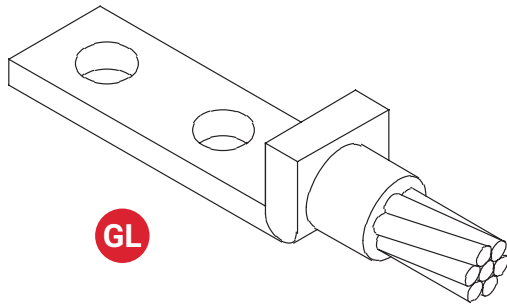

**NEMA Drilled Lugs-B-121 Series**

All lugs are tin-plated copper.  
Pat. No. 4,196,960.

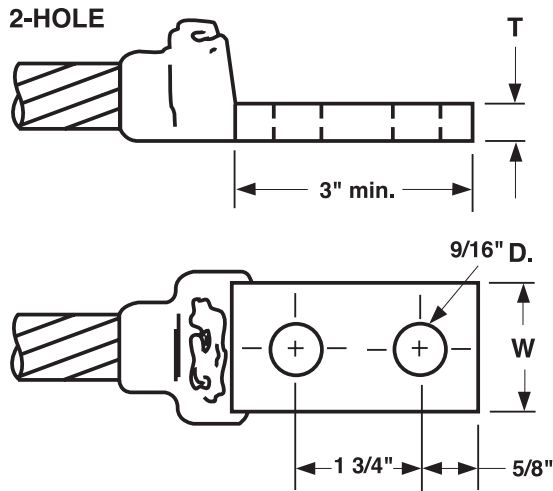

**NEMA Drilled Lugs-B-122 Series**

## COPPER LUGS

- Lugs and connections for equipment and structures. Ideal for power applications.
- Concentric stranded copper cable is listed.
- **Bold letter** in mold part number is the price key.

## REQUIRED TOOLS

**Handle Clamps** **L160** for **C** Price Key Molds

**Flint Ignitor** **T320** (Included with Handle Clamp but also available separately)

## SUGGESTED TOOLS

Cable Cleaning Brush	T313 or T314
Slag Removal Spade	B136A or B136B
Mold Cleaning Brush	T394
Torch Head	T111

## ACCESSORIES

See Section A

Cable Size	Mold Part No.	Weld Metal	Lug Size T X W	GI Lug Number	
				1 Hole	2 Hole
4	GLC-CE1L	32	1/8 x 1	B-121-CE	B-122-CE
2	GLC-CE1V	32	1/8 x 1	B-121-CE	B-122-CE
1	GLC-CE1Y	32	1/8 x 1	B-121-CE	B-122-CE
1/0	GLC-CE2C	45	1/8 x 1	B-121-CE	B-122-CE
2/0	GLC-CE2G	45	1/8 x 1	B-121-CE	B-122-CE
3/0	GLC-CE2L	65	1/8 x 1	B-121-CE	B-122-CE
4/0	GLC-DE2Q	65	3/16 x 1	B-121-DE	B-122-DE
250	GLC-DE2V	65	3/16 x 1	B-121-DE	B-122-DE
300	GLC-EE3A	90	1/4 x 1	B-121-EE	B-122-EE
350	GLC-EE3D	90	1/4 x 1	B-121-EE	B-122-EE
500	GLC-EG3Q	150	1/4 x 1 1/2	B-121-EG	B-122-EG

# Field Information Guide

A. **Problem:** Mold doesn't close tightly

**Check For:**

1. Adjustment of handle clamps.
2. Out-of-round or bent cables.
3. Dirt or slag in mold parting line.

**NOTE:** Use "C" clamp if necessary.

B. **Problem:** Connection covered with excessive slag

**Check For:**

1. Weld material leaking past the disk caused by:
  - (a) Chipped graphite at tap hole.
  - (b) Disk moved when weld material was dumped.
  - (c) Disk not properly seated.
  - (d) Forgot disk.

**NOTE:** A small amount of slag on the surface is not abnormal.

C. **Problem:** Porous connection

**Check For:**

1. Moisture present either in conductor or mold.

Remedy:

- (a) Dry the conductor under wet conditions.
- (b) Heat mold with torch (to above 212°F) or by igniting weld metal in mold without any conductors, taking care to prevent burns from the hot metal running out of the mold. Do not use the second method of heating if the mold has wear plates.

2. Other contaminants (oil, insulation, etc.) present in conductors.

Remedy:

- (a) Wash conductor with a suitable solvent.
  - (b) Remove insulation if present between strands.
3. Cadweld Mold Sealer in weld cavity of mold.

Remedy:

- (a) Always apply Cadweld Mold Sealer material to conductor after mold is closed.

D. **Problem:** Conductors do not weld

**Check For:**

1. Conductors were not properly cleaned and dry.

Remedy:

- (a) Remove oxides with wire brush (T313 or T314). If heavily oxidized, have fresh-cut conductor end and use Cadweld Heavy Duty Molds.
- (b) Dry conductors with torch.

2. Conductors not properly positioned in the mold.

Remedy:

- (a) Check for proper gap or butting as required (see mold tag and positioning instructions packaged with mold).
- (b) Check to be sure gap is centered under tap hole.

E. **Problem:** Weld metal leaks around conductor

Remedy:

1. Use Cadweld Mold Sealer material around mold opening after mold is closed.
2. Use molds with wear plates (which also act as chill plates).
3. Check for proper mold. Mold must be sized for the cable being welded.
4. If mold is excessively worn, replace with new mold.

F. **Problem:** Connection has "Fins" - losing metal

**Check For:**

1. Mold not completely closed.
2. Mold worn beyond useful life and needs replacement.

G. **Problem:** Cables pull out of mold during welding

Remedy:

1. Use clamp (Cadweld B-265) or other means to relieve tension on conductors when welding.

# Field Information Guide

H. **Problem:** Insufficient fill metal to cover conductors

**Check For:**

1. Use of proper weld metal size (see mold tag).
2. Too large a gap between conductors (see positioning instructions).
3. Mold leakage.
4. Conductors moved during welding process.

Remedy:

- (a) See Remedy E.
- (b) See Remedy F.
- (c) See Remedy G.

I. **Problem:** riser too high

**Check For:**

1. Use of proper weld metal size (see mold tag).
2. Moisture in mold or conductor.

Remedy:

- (a) See Remedy C.

J. **Problem:** Short mold life (overall AVERAGE SHOULD BE 50)

Remedy:

1. Hard-drawn copper or DSA Copperweld requires the use of Cadweld B-265 cable clamp.
2. Mold should be cleaned with T-394 or other soft brush, cloth or newspaper.  
DO NOT USE WIRE BRUSH.
3. Care should be used in removing mold from finished connection to prevent chipping of the mold.

K. **Problem:** When welding to steel, weld does not "stick" to the steel

Remedy:

1. Steel must be cleaned with rasp or grinder to bright metal. All mill scale, paint and/or other coating must be removed. Wire brushing will NOT suffice. Grease must be removed with a solvent before cleaning. When grinding, use a vitrified wheel only.
2. Galvanized surfaces normally require cleaning with only a wire brush or emery cloth. However, extra-heavy galvanized steel must be cleaned with a rasp (T321).
3. If steel is moist, heat with a torch (from the back side if possible). Any carbon deposit from the flame must be removed.
4. Conductors not in proper position. Check instruction sheet.

L. **Problem:** Molten metal "spits" out of crucible when making connection

Remedy:

1. See Remedy C.

# Materials, Tools & Accessories

## SECTION A

### SAFETY FIRST

nVent ERICO recommends SAFETY FIRST when making Cadweld connections. We offer safety equipment, including gloves and glasses as shown.

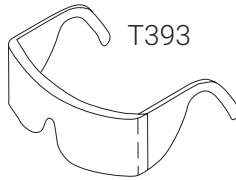

#### Safety Glasses

These glasses may be worn separately or over prescription glasses.

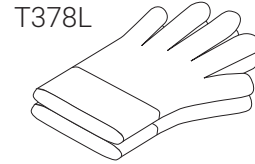

#### Gloves

Heavy canvas gloves with leather palms.

### CADWELD WELD METAL

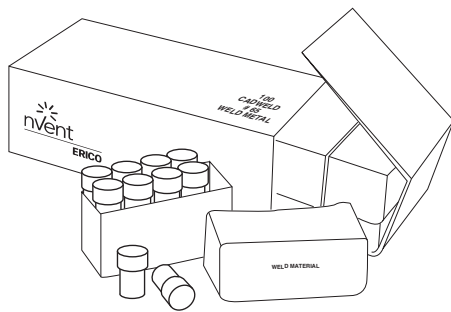

Cadweld Weld Metal is a mixture of copper oxide and aluminum, packaged by size in plastic tubes. Each tube contains the starting material at the bottom of the plastic tube, with the Weld Metal on top. These materials are not explosive and not subject to spontaneous ignition. These containers are packaged in boxes along with metal disks. Each weld uses one disk. Disks are included with the weld metal.

Five types of Cadweld Weld Metal are used for grounding connections:

1. F20 or standard Weld Metal is used for all grounding connections with the exception of those to cast iron or to load bearing rail. The Standard Weld Metal containers have clear (or natural) caps.
2. **XL Weld Metal is used with Cadweld Exolon molds. Cadweld Exolon Weld Metal containers have white caps.**
3. XF-19 Alloy Weld Metal is used for all connections to cast iron such as Type HB and others. XF-19 Weld Metal containers have orange caps.  
For DUCTILE IRON, see Section 3 in Catalog A1A, Cast Iron connections.
4. Cadweld F80 Alloy Weld Metal is used for all connections to load bearing rail such as Type W Bonds. F80 Weld Metal containers have yellow caps.
5. Cathodic connections require different weld metal and molds. Contact nVent for cathodic connection applications.

### CADWELD MOLDS

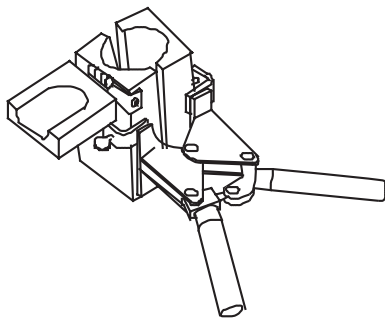

A semi-permanent graphite mold is used for making most Cadweld connections. The mold controls the direction and speed of the molten Cadweld weld metal flow and its final shape. The graphite used in a Cadweld mold is a high temperature type that lasts for an average of 50 or more Cadweld connections under normal usage.



# Materials, Tools & Accessories

## SECTION A

### ADAPTING MOLDS TO FIT CONDUCTORS

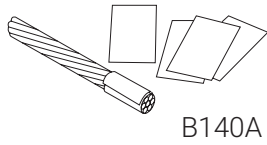

Cables smaller than indicated on mold tag can be welded by using either wrap sleeves or adapter sleeves.

#### Cadweld Wrap Sleeve B140A

Cadweld Wrap Sleeve is wrapped around the cable until the diameter is about the same as the cable opening in the mold.

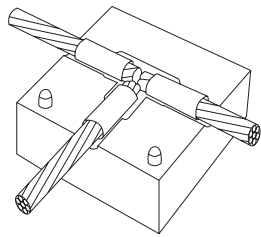

#### Cadweld Adapter Sleeves

Cadweld Adapter Sleeves are used to adapt a limited range of smaller size cables to a larger size Cadweld Mold.

Cable Size		Adapter Sleeve Part No.	Use in Mold for Stranded
<b>Concentric Strand</b>	<b>Solid</b>		
#12,14	#10,12,14	B133-1H	#6
#7,8,10	#6,8	B133-1L	#4
#6	#5	B112	#2
#4,5	#3,4	B133-1V	#2
#3,4	#2	B133-1Y	#1
#2	#1	B133-2C	1/0
#1	1/0	B133-2G	2/0
1/0,1	2/0	B133-2L	3/0
2/0,1/0	3/0	B133-2Q	4/0

### CADWELD SLEEVE KIT (T427)

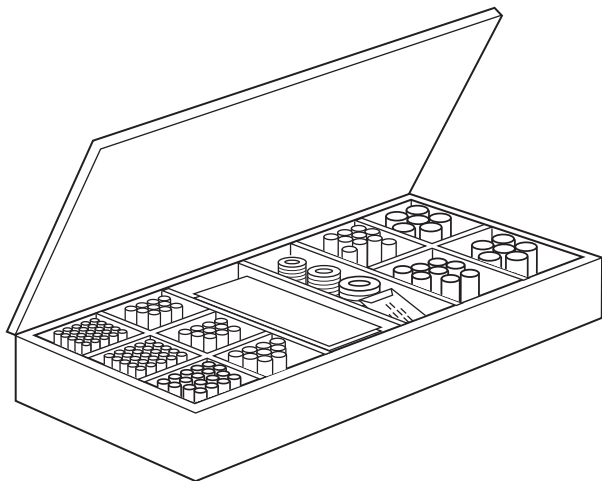

T427 Includes:

Part No.	Quantity
B1331H	25
B1331L	25
B112	18
B1331V	10
B1331Y	10
B1332C	9
B1332G	10
B1332L	8
B1332Q	12
B140A	10
B117A	20
B117B	10
B117C	10
T320A	10

# Materials, Tools & Accessories

## SECTION A

### ADAPTING MOLDS TO FIT CONDUCTORS (CONT.)

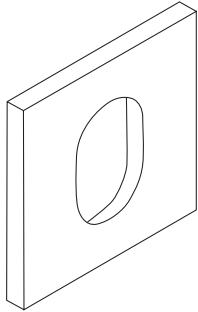

#### Packing

Packing consists of either preformed ceramic packing or sometimes B140A or B141A copper wrap shim. Packing is required on all rebar connections.

#### Cadweld Mold Sealer

T403 Cadweld Mold Sealer is ideal for sealing hot or cold molds to retard leakage from large stranded conductors. It is required on certain molds such as Types HA, HB, HC, VG and VN. It prolongs useful mold life when the cable opening becomes worn.

It is available in a convenient 2 pound package.

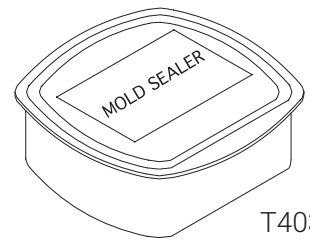

T403

### CABLE AND WORK SURFACE PREPARATION

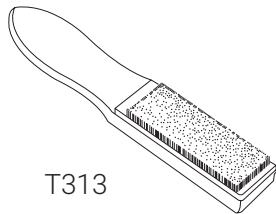

T313

#### Cable Cleaning Brushes

Two types of brushes are available to aid in removing oxides from copper surfaces.

T313 Card Cloth Brush with short stiff bristles is generally preferred for cleaning concentric conductors and busbars, which are not heavily oxidized.

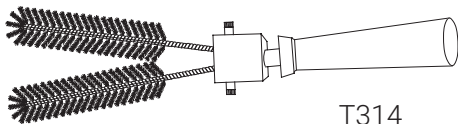

T314

T314 Cable Cleaning Brush cleans any conductor and is especially useful for coarse or very dirty conductors. The brushes can be rotated to provide new cleaning bristles and are replaceable.

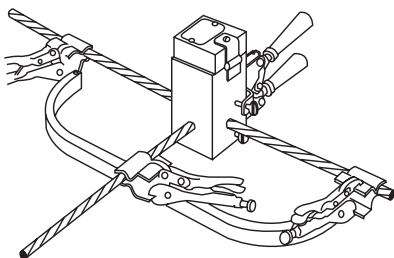

B265

#### Cable Clamp B265

The B265 Cable clamp should be used with hard drawn copper cable, Copperweld DSA® conductor or any cable under tension.

Use of the clamp aids in preventing cable movement and prolongs mold life.

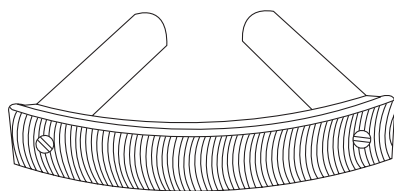

T321

#### Rasp

T321 rasp is used to remove rust from any steel surface or galvanizing from hot dipped galvanized steel to expose the bare steel for welding. The curved blade makes it an efficient tool for flat surfaces.

T321A replacement blades are also available.

# Materials, Tools & Accessories

## SECTION A

### CABLE AND WORK SURFACE PREPARATION (CONT.)

---

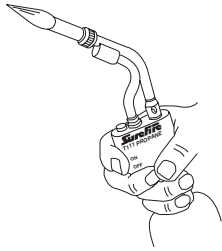

T111

#### Torch Head

T111 self igniting propane torch head. Squeeze the control knob for an instant flame. Release the control knob and the flame extinguishes. No flame adjusting. The burn tip remains cool during normal use. Operates on its side or upside down. Can withstand 60MPH winds without flareout.

Fits all standard 14 and 16 oz. propane cylinders.

SUREFIRE™ is a trademark of IPI

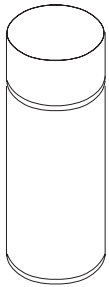

T372A

#### Galvanizing Touch-Up

Easy to use galvanizing paint in a spray can is used to touch up heat affected areas on galvanized steel surfaces after welding. The damage to the galvanizing is often minimal so the repair is often cosmetic. T372A galvanizing compound is available in 12 ounce aerosol can.



T358

T358 Regalv is a 97% zinc rich organic coating which also can be used to repair galvanized surfaces. The brush is attached to the cap.

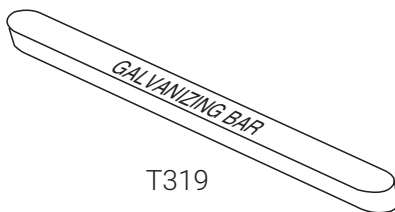

T319

T319 Galvanizing Bar is used to repair a galvanized surface that has been damaged by welding or drilling. This is a low temperature, self-fluxing material. Often there is sufficient heat after making the Cadweld connection to melt the bar or a small torch may be used.

# Materials, Tools & Accessories

## SECTION A

### MOLD CARE AND USE

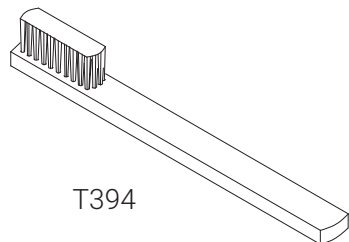

T394

#### Mold Cleaning Brush

Mold cleaning brush T394 should be used to remove slag from molds – especially vertical split molds.

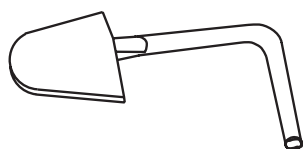

B136A  
B136B

#### Slag Removal Spades

Slag Removal Spades are useful for removing the slag after making a Cadweld connection – especially useful with horizontally split molds.

Slag Spade Part No.	Use With Price Key Mold	Using Weld Metal Size
B136-A	A,C, & R	#65 & Smaller
B136-B	C,D,F & R	#90 & Larger

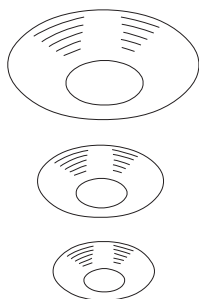

#### Disks

Each time a weld is made, a new disk is required. The disk sits on the bottom of the crucible. Its purpose is to hold the powdered weld metal until the reaction takes place. The slag produced by the reaction rises to the surface and the molten copper settles to the bottom of the crucible where it melts the disk and flows over the conductors to produce a permanent molecular bond.

Disks are available in three sizes:

B117A used in molds using #15 thru #32 weld metal (3/4" diameter).

B117B used in molds using #45 thru #115 weld metal (1" diameter).

B117C used in molds using #150 thru #500 weld metal (1-1/2" diameter).

Disks are included with the Weld Metal.

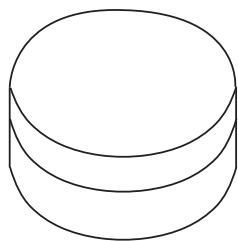

T328D

#### Disk Kit

A disk container (T328) which includes 20 of each of the three sizes of steel disks is available for your convenience. Kit Part No. T328D.

# Materials, Tools & Accessories

## SECTION A

### MOLD CARE AND USE (CONT.)

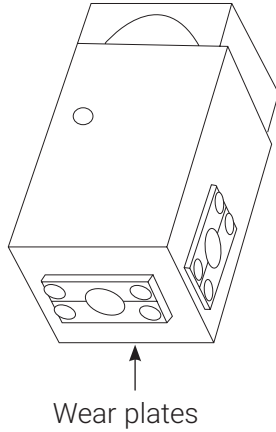

#### Wear Plates

Wear plates reduce mechanical abrasion of molds at cable entry points and help prevent leakage of molten metal (particularly on larger 7 strand conductor). These features prolong mold life.

Most Cadweld Molds are available with factory-mounted wear plates for the following sizes:

- Copper Cable: 1/0 AWG thru 500 Kcmil
- DSA Copperweld: 7/#10 thru 19/#6
- Ground Rods: 1/2" thru 1"

To order WEAR PLATES, specify: Mold Part No. followed by the suffix "-W" i.e., TAC-2Q2Q-W.

Not available with types HA, HB, HC, LJ, certain PTs & PCs, RR, VB, VF, VG, VN, XA, XBQ or XBZ.

Following are the number of wear plates (W.P.) used on the various mold types listed in this catalog.

TYPE	W.P.	TYPE	W.P.	TYPE	W.P.
GB	1	HT	2	RC	2
GB-GR	2	LA	1	RD	2
GB-GT	3	LE	2	SS	2
GL	1	LL	1*	TA	3
GR	2	PC	3**	VS	1
GT	3	PT	4**	VT	2
GY	3	RA	1	VV	1
HS	1	RB	2	XB	4

\* Available only on molds for 2" and narrower bus size.

\*\*Available only on mold for 1/0 (or 7/#10) and larger run and tap.

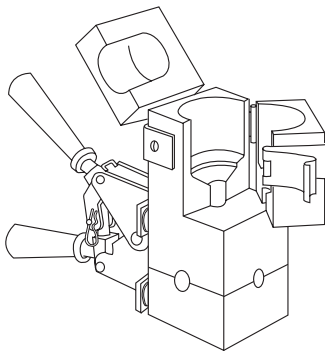

#### Split Crucible Molds

Molds made with a horizontal opening and solid crucible section may be specified as a SPLIT CRUCIBLE TYPE. The advantage of the SPLIT CRUCIBLE MOLD is easier cleaning, but lead times are longer.

To order a SPLIT CRUCIBLE TYPE specify: Mold Part No. followed by the suffix "L" i.e., TAC2Q2QL.

Available in Type TA, XA, XB (C & D mold price only), LE and LJ connections.

# Materials, Tools & Accessories

## SECTION A

### MOLD FASTENING AND MOUNTING

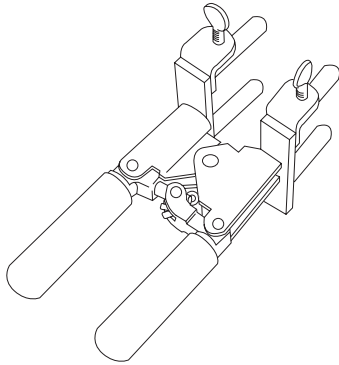

#### Cadweld Handle Clamps

Handle clamps such as the one shown are required for most molds. Specialized frames with handles are used on some molds. Flint ignitors are included with all handle clamps. The following handle clamps are most widely used.

1. L160 for all molds having a "C", "E", "Q" or "R" mold price listing.  
(3" wide molds)
2. L159 for all molds having a "D", "F", "J" or "Z" mold price listing  
(4" wide molds)

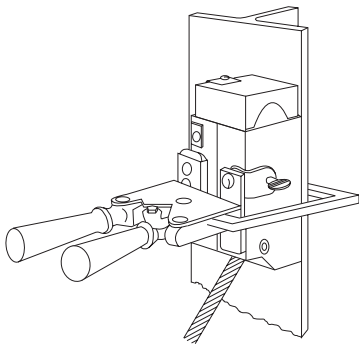

#### Vertical Surface Mold Support

The Cadweld Mold can be securely held to a vertical "H" column or angle by using the Vertical Surface Mold Support. It is easily attached to an existing L159 or L160 Handle Clamp. For use with Types VB, VG, VN, and VS molds, fits steel up to 1" thick, for Type VF mold, 3/4" thick.

B134: For use with L160 E-Z CHANGE Handle Clamp

B135: For use with L159 E-Z CHANGE Handle Clamp

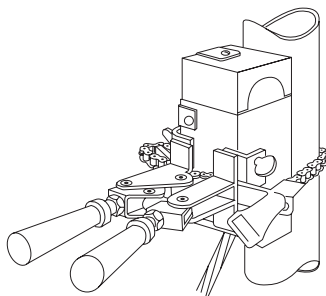

#### Chain Support Handle Clamps

The Cadweld mold can be securely held to a pipe using the clamp assembly consisting of a modified L159 or L160 Handle Clamp with built-in Pipe Attachment.

Clamp Part No.	Fits Mold Price	For Following Connection Types	Pipe
B159V	D & F	VS,VF,VB, & VV	Vertical
B160V	C & R	VS,VF,VB, & VV	Vertical
B159VT	D & F	VT	Vertical
B160VT	C & R	VT	Vertical
B159H	D & F	HA,HS,HC, & HT	Horizontal
B160H	C & R	HA,HS,HC, & HT	Horizontal

The above clamps are equipped with 20" length of chain which will fit up to 4" pipes. Extra 20" length of chain, B158, is available to fit up to 10" pipes.

# Materials, Tools & Accessories

## SECTION A

### MOLD FASTENING AND MOUNTING (CONT.)

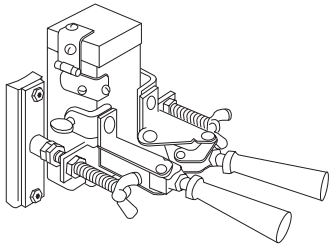

#### Magnetic Handle Clamps

The Cadweld mold can be securely held to a large flat or slightly curved vertical surface using the Handle Clamp with Magnetic Support. Used on vertically split molds.

Clamp Part No.	Fits Mold Price Key	Minimum Width Required*
B396	C & R Price Key	8"
B159M	D & F Price Key	10-1/2"
B399AM	T Price Key	6"
B399BM	P & N Price Key	7"

\*Width will vary slightly depending upon the type of connection being made.

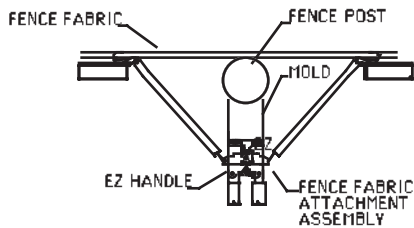

#### Fence Fabric Attachment Assembly

An easy to use, labor saving, Fence Fabric Attachment Assembly fastens to your existing L159 or L160 Handle Clamp to firmly hold your mold to the fence post after the fence fabric has been attached. Ideal for retrofit jobs.

Part No.	Fits Handles
B827A	L160, L159

### GROUND ROD SPECIALTY TOOLS



#### ERICO Ground Rod Drivers

Product No.	Description
EGRD58	5' driver body with insert for up to 5/8" ground rods
EGRD58I*	Replacement insert for 5/8" ground rods
EGRD34	5' driver body with insert for up to 3/4" ground rods
EGRD34I*	Replacement insert for 3/4" ground rods

\*Both 5/8" and 3/4" inserts fit standard body of EGRD58 or EGRD34.

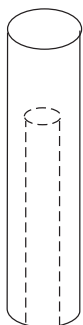

#### Ground Rod Driving Sleeves\*\*

Use a Cadweld ground rod driving sleeve to prevent mushrooming the top of the ground rod.

Ground Rod Size	Part No.
1/2" Copperbonded or Steel Rod	B137-14
5/8" Copperbonded (.563" diameter)	B137-16
5/8" Steel (.625" diameter)	B137-31
3/4" Copperbonded (.682" diameter)	B137-18
3/4" Steel (.750" diameter)	B137-33
1" Copperbonded (.914" diameter)	B137-22
1" Steel (1.00" diameter)	B137-37

\*\* For plain (unthreaded) ground rods only.

# Materials, Tools & Accessories

## SECTION A

### GROUND ROD SPECIALTY TOOLS (CONT.)

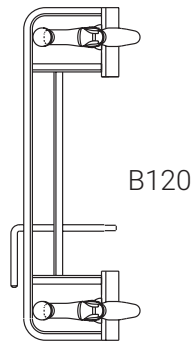

#### Ground Rod Splice Clamp

The B120 Ground Rod Splice Clamp must be used to support the upper rod and provide a method of correctly positioning the rods and mold while splicing the rods. (Type HDGB connection).

### ACCESSORY TOOLS

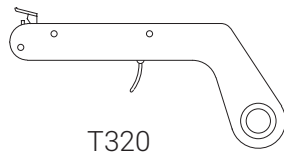

#### Flint Ignitors

T320 Cadweld flint ignitors are used to ignite the starting material when making a Cadweld connection. An ignitor is included with each handle clamp or frame. T320A Replacement Flints are also available.

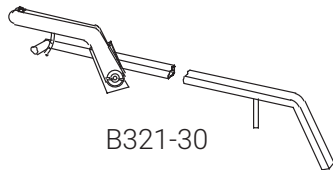

#### Flint Ignitor Extension

B321-30 Flint Ignitor Extension attaches to the T320 Flint Ignitor and allows the installer to be about 30" from the mold. Ideal for such applications as making a mold in a narrow trench while the installer is at ground level.

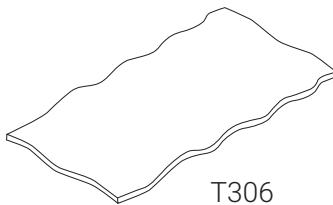

#### Ceramic Blanket

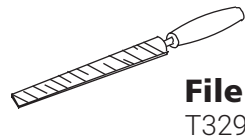

**File**  
T329



**Pliers**  
T304



**Screwdriver**  
T305

The woven Ceramic Blanket (Part T306) can be used to hold a hot mold or keep the work surface free of slag when cleaning the mold.

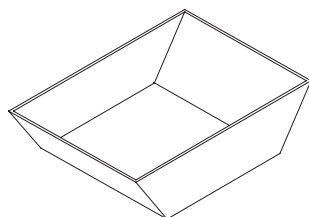

#### Welding Tray

The Welding Tray (Part XLB974-B2) can contain a spill of molten weld metal. It is for personnel safety. Recommended when working overhead or over expensive equipment.

XLB974-B2



# Materials, Tools & Accessories

## SECTION A

### TOOL KITS

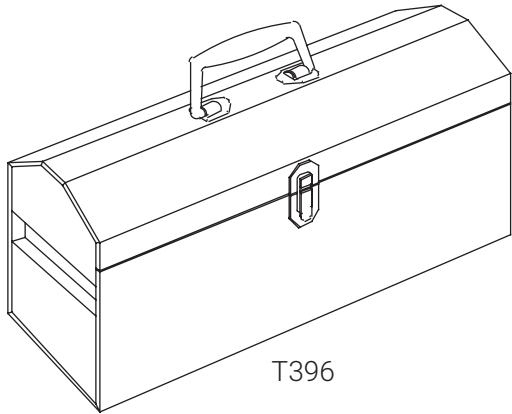

T396

Tool Box T396 is included in Tool Kit T315A

#### Tool Box T396

A tool box is highly recommended to carry tools, molds, weld metal and a propane torch.

#### Tool Kit T315A

Other Tool Kits can be made for your particular requirements.

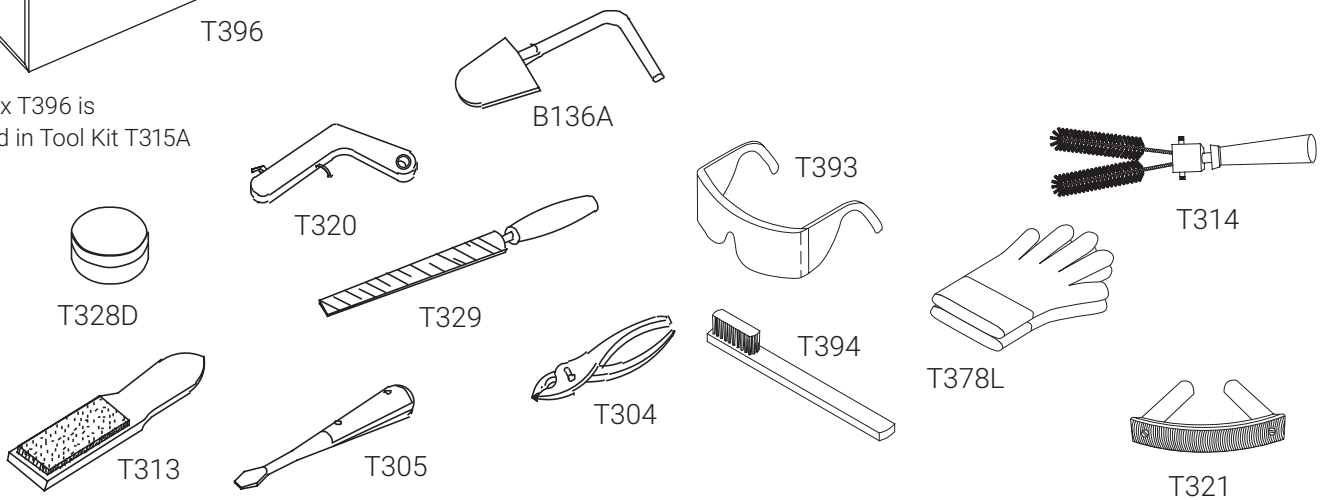

T328D

T320

T329

T313

T305

T304

T394

T378L

T314

T321

### TOOL TRAY

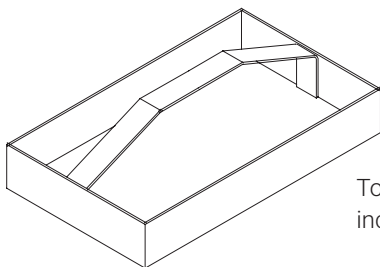

T331

Tool Tray T331 is not included in Tool Kit T315A

#### Tool Tray Only: T331

Ideal for carrying one or two molds, weld metal, propane torch and tools.

### TOOL TRAY

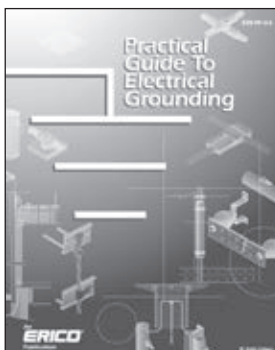

Part No.	Description
G157LT99	Practical Guide to Electrical Grounding

# Materials, Tools & Accessories

## SECTION A

### GROUND SYSTEM TESTERS

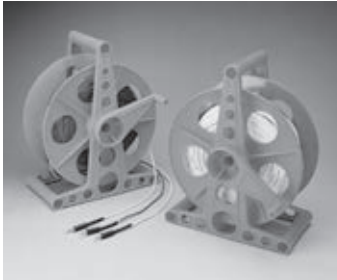

EST Reel Kit 500

#### EST Series

Part No.	Description
EST 101	2 pole resistance, 3 pole ground to earth resistance measurement @128Hz
EST 201	2 pole AC resistance, 3 pole ground to earth resistance measurement, 4 pole soil resistivity measurement
EST 301	2 pole AC resistance, 2 & 3 pole ground to earth resistance measurement, 4 pole soil resistivity, and clamp-on stakeless and selective adapters
ESTREELKIT500	EST Reel Kit 500 feet long (includes two reels)



EST101



EST201



EST301



Our powerful portfolio of brands:

**CADDY   ERICO   HOFFMAN   RAYCHEM   SCHROFF   TRACER**



[nVent.com/ERICO](https://nVent.com/ERICO)