

MINSTER®
SERIES PM3
Piece-Maker III®



BULLETIN 132B

MINSTER®

Series PM3

Piece-Maker III®

**Two Point, Eccentric Shaft
Dynamically Balanced,
Progressive Die,
Straight Side Presses**

Minster Series PM3 presses provide the ultimate in consistent accuracy in automated high speed blanking operations in the 125 to 300 ton range.

The PM3 was designed specifically for lamination work. Therefore, many of the PM3's features help insure that the machine will maintain its fine accuracies throughout years of operation.

Expensive lamination dies last longer in a Minster PM3 because of its unique design. The massive frame, full eccentric shaft with six main bearings, along with the heavy steel connections and wrist pins combine to provide a machine that is more stable at high lamination speeds.

PM3 presses also feature hydrostatic and hydrodynamic slide guiding and main bearing support that accurately guide the punch into the die to increase die life. In addition, an exclusive "hydraulic supported screw thread" system removes the clearances from slide shutheight adjustment parts, enhancing bottom-dead-center repeatability and part consistency.

In-Die Staking

Unique features such as shutheight stabilization, hydraulic supported screw threads, a deep slide with long gib guiding, hydraulic quick lift slide and consistent slide bottom-dead-center repeatability make the PM3 the ideal press for in-die staking operations. Add to these features the adjustable-in-motion (A.I.M.) control and they provide accuracy so critical when staking laminations within the die, while at the same time promote increased die life and die accessibility.

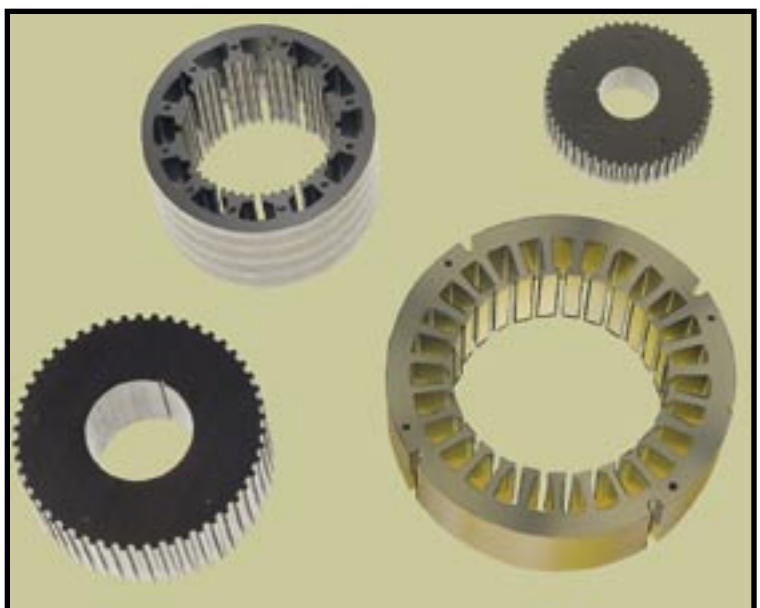
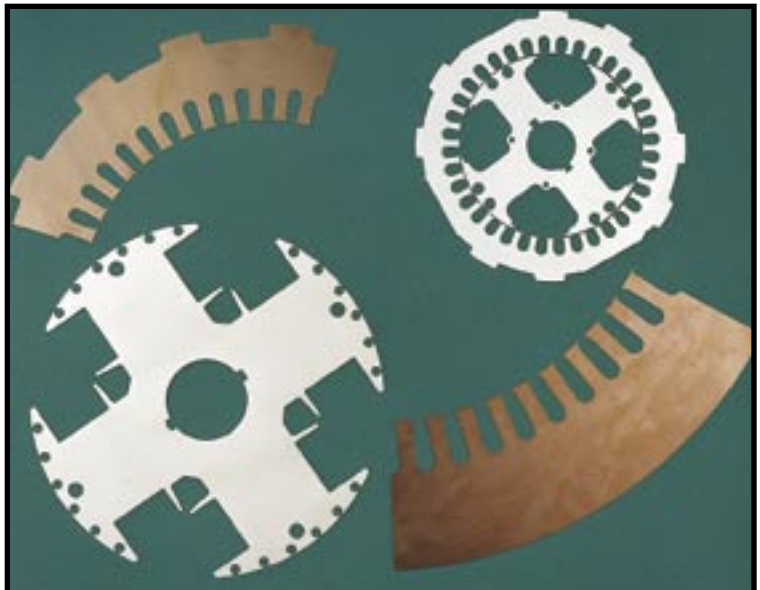

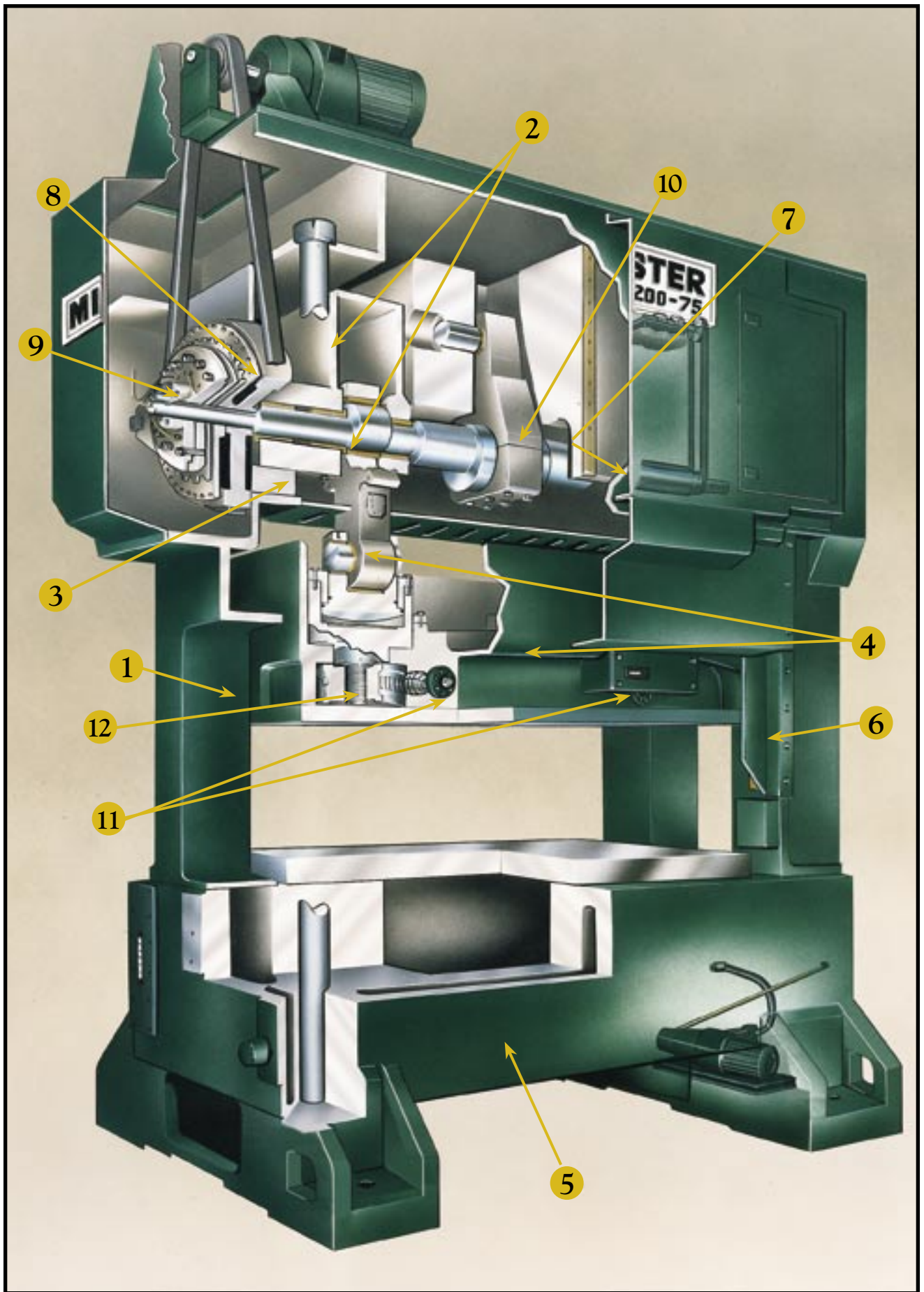



Cast Construction Reduces Vibration. 1

Minster Piece-Maker PM3 Series dynamically-balanced presses feature four-piece tie rod cast construction in the 125 and 200-ton models, while the PM3-300 has a welded crown and bed. Minster's construction provides the compressive strength and vibration dampening so essential in building a precision press for progressive die work. The PM3 gives the user less punch wear, better die life and greater part accuracy because the vibration is held to a minimum.

Crown and Eccentric Shaft Provide Strength and Resist Deflection. 2

The massive crown of the Minster PM3 is engineered to withstand the severe stresses of lamination operation. A deep crown design backs up the eccentric shaft at any angle against forces created by the application, and load carrying members evenly distribute these forces into the crown structure.

In addition, the eccentric shaft provides these benefits:

- Resists deflection.
- Bearings are closer to the connection where the stamping force is exerted.
- Allows for connections to be moved farther apart.
- Resists tipping forces associated with progressive die work.
- It is a full torsional member.

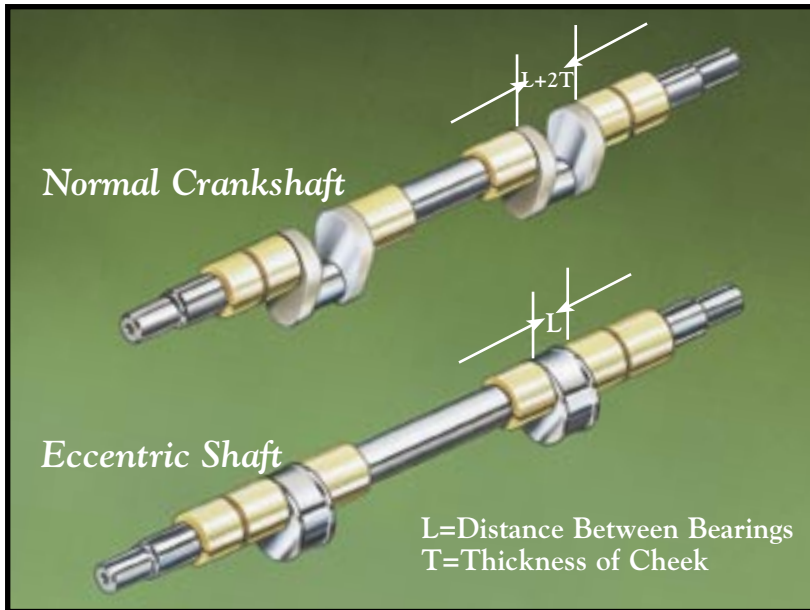

Precision-Fitted Support Block. 3

A precision-fitted support block between the main bearing caps and the top of the uprights helps relieve the stresses placed on bearing cap screws by snap-thru forces and adds to the rigidity of the eccentric shaft.

Rigid Slide and Connections. 4

The PM3 slide is designed to minimize deflection under full loading. The heavy steel connections combined with the large wrist pins are made specifically for high speed blanking. This feature, designed to handle snap-through forces equal to 50% tonnage rating of the press, reduces punch penetration and promotes die life.



Massive Bed for Stability and Precision. 5

The massive bed of the PM3 minimizes deflection, increasing die life and improving part quality. In addition, the bed design incorporates troughs to collect die lubrication. Large bed openings provide access for lamination stacking chutes.

Eight Point Hydrostatic/Hydrodynamic Gibbing for Precision Slide Guiding. 6

The PM3 slide is guided by square gibbing at each corner, incorporating both hydrostatic and hydrodynamic bearing technology. The hydrostatic and hydrodynamic guiding design work in tandem to provide constant centering force throughout the press stroke, resisting the slide tipping movements caused by the high impact loading of lamination stamping. This guiding design promotes better part consistency and longer die life and, with the slide being centered in a static mode, allows for more accurate

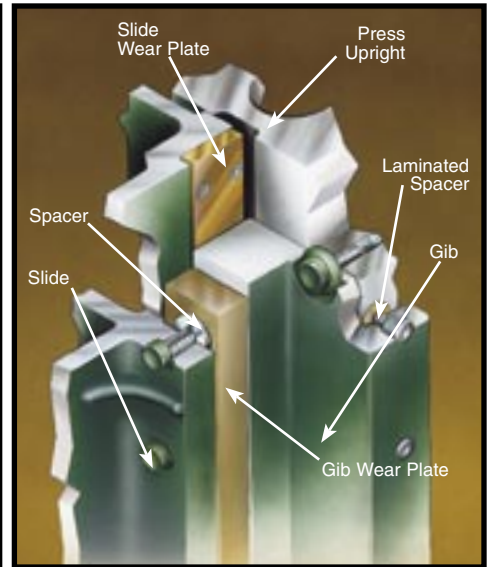

MINSTER® MonitorFlow Continuous, Monitored Press Lubrication. 7

The patented Minster MonitorFlow Pressurized Recirculating Oil Lubrication System supplies a continuous flow of filtered oil under pressure to all bearing surfaces. It also monitors the flow to these points as well as oil level and pressure in the entire system, and protects the bearings by stopping the press operation in the event of a lubrication fault. The **PMC Control Screen** instantly shows which flow switch signalled the fault, helping to pinpoint the problem area.



The Basics of Hydrostatic/Hydrodynamic Technology

Hydrostatic pressure applied from all gib surfaces keeps slide centered when in a static condition and when slide is moving at a slow velocity such as near BDC. Hydrodynamic pressure also aids in centering the slide through the high velocity portion of its stroke. The result is extreme guiding accuracy and resistance to tipping moment at all points of the slide stroke.

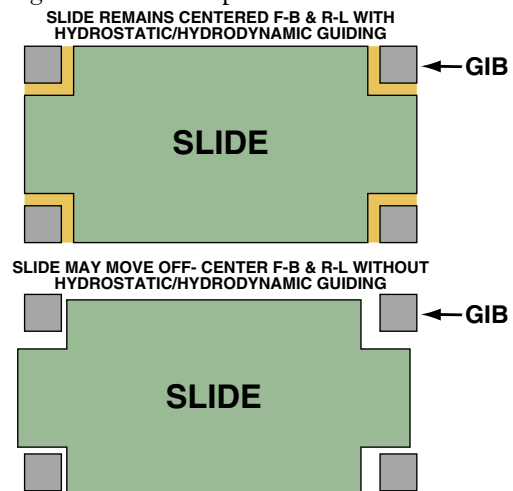

Flywheel Drive Arrangement for Maximum Press Efficiency. 8

The Minster PM3 Series presses are flywheel type presses running at higher speeds for punching, notching, and blanking operations on lamination materials. The clutch and brake unit is mounted on the eccentric shaft and the flywheel rotates on anti-friction bearings. An eddy-current brake supplies quick slowdown of flywheel for responsive operating speed changes.



High Performance, Hydraulic Clutch and Brake Unit. 9

The Minster PM3 delivers the maximum torque possible to provide fast starting and stopping through a hydraulically-actuated friction clutch and synchronized, spring-applied disc brake. The hydraulic pressure applied to engage the clutch also disengages the brake.



Dynamic Balancer System. 10

The Dynamic Balancing System on the PM3 greatly reduces the effect of the slide inertia forces caused by running at high speeds. This reciprocating balancer helps maintain precise slide bottom-dead-center repeatability resulting in less die wear and greater part accuracy. It also allows the press to run at higher speeds and reduces press vibration.

Precise Shutheight Adjustment. 11

Shutheight changes on the PM3 are made through two large connection screws. An electro-hydraulically operated shutheight adjustment mechanism is standard.

Shutheight Indicator. A digital shutheight indicator gives the operator a constant read-out of the dimensional opening between the slide face and the bed or bolster, displaying to a thousandth of an inch. (Metric calibration is also available.)

Hydraulically-Supported Screw Threads 12

PM3 presses incorporate hydraulically-supported screw threads, utilized as part of the Adjustable-In-Motion option. This feature eliminates the effects of vertical clearances by introducing an oil film between the threads, while still allowing rotation of the adjusting nut during stamping operation. The extreme stiffness of the system reduces snap-thru effects, resulting in reduced punch penetration contributing to increased die life.

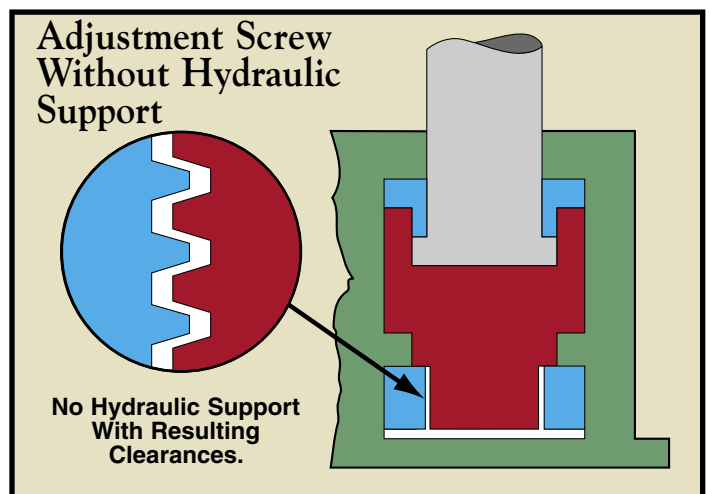
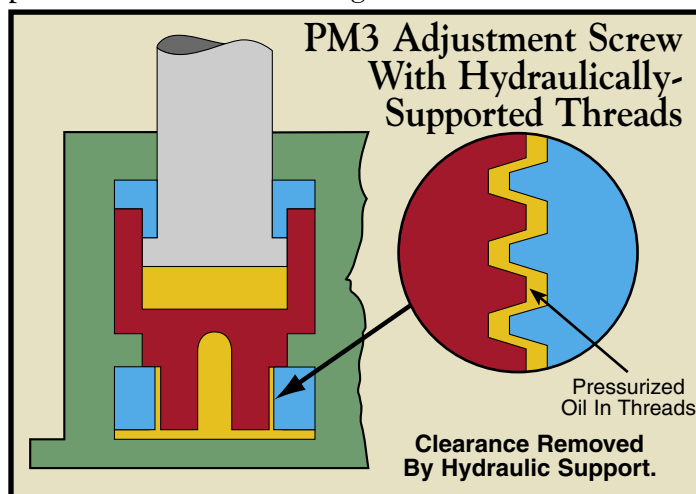

Hydraulic Quick-Lift.

Quick access to dies is provided by a hydraulic system which lifts the slide as much as three inches (76 mm). The hydraulic system returns the slide to the original shutheight position against a mechanical stop, maintaining tool settings. This feature enhances die accessibility and allows fast and easy unsticking from the bottom even with shorter strokes and higher production speeds associated with lamination stamping, thus contributing to greater production efficiency.

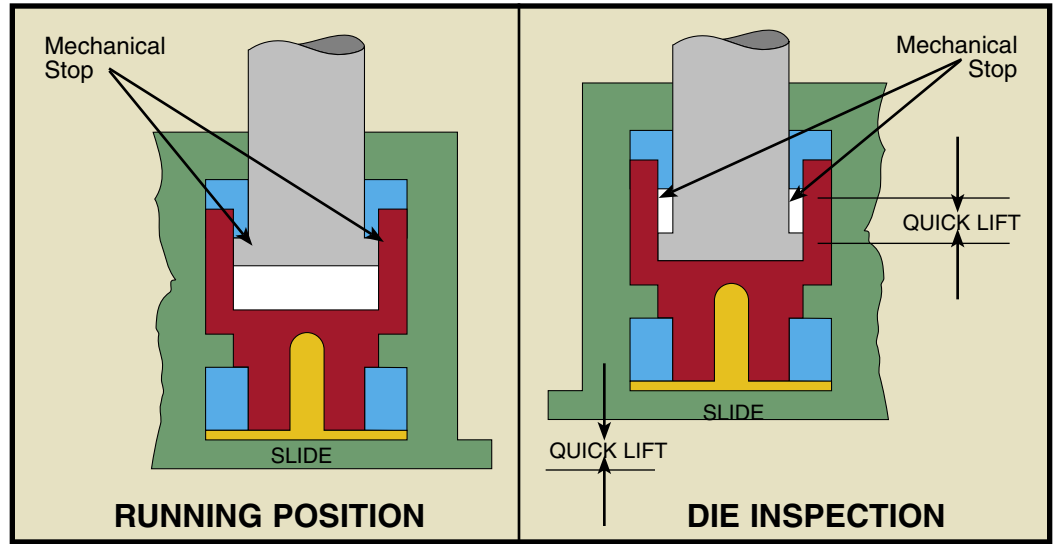

Other Options.

- Adjustment-In-Motion (A.I.M.)
- Die Space Enclosures
- Oil Cooler
- Quick-Die-Change Systems & Rollers
- Feeds
- Stock Lubrication
- Material Handling Systems
- Air Operated Flywheel Brake

Electrical Controls Standard PM3 Electrical Controls:

Minster Production Management Control (PMC) - Ask for Bulletin 146A

- The PM3 control is housed in a NEMA 12 "Style 100" enclosure, minimizing floor space. Control includes a fused disconnect switch, motor starters, control transformer, Allen Bradley PLC, color touch screen and operator buttons to enable inch, setup cycle, and continuous operation.
- Featuring a 10.4" color TFT touch screen display mounted in the enclosure face, the display consolidates operator interaction of Motor controls, Programmable Limit Switch, Production and Maintenance Schedule Counters. This, combined with complete Machine Diagnostics enable clear and precise maintenance and production management. Additional features include Tool Storage, Stopping Time Readout, Brake Monitor, Lubrication Indicators, Speed Control, Motor Load Meters, Stock Lubrication Interface, Blowoff Valve Interface, Production Counters, and Machine History Counters.
- Main Operator/Setup Station includes selector switches, push buttons, and lights on the pedestal enclosure configured to initiate press operation. Pedestal mounted devices include Power Off/On, Supervisory Control Off/On, Setup Cycle, Continuous, Function Enable, Run, Continuous Arm & Ready, Setup Cycle Arm & Ready, Stop & Top Stop.
- Press-mounted Setup Station includes Inch selector and push buttons, Slide Adjustment Up/Down, Slide Quick Lift and Stop Control. Optional Selectors include Die Door Open/Close, Die Lights Off/On, Manual Stock Lube, and Die Protection Connections if provided.

- Press-mounted controls include two barrier guard receptacles, and an additional stop control button on the rear of the press.
- Minster Programmable Limit Switch Control allows for quick adjustment, auto top stop at all press speeds, and includes digital stroke position indicator and stopping time readouts.
- Tandem Clutch Valves — solenoid operated and actively monitored.



PMC Control Options:

- Adjustment-In-Motion (A.I.M.).
- 2 or 4 Channel Tonnage Monitor.
- 16 Point Die Protection.
- Die Space Lighting.

MINSTER®

Series PM3 Specifications & Dimensions

Metric Specifications and Dimensions in "Italics>"

Dimen.	Press Size	PM3-125	PM3-200-60	PM3-200-75	PM3-300
	Tonnage (U.S. Tons)	125 1112 kN	200 1780 kN		300 2669 kN
	Slide Stroke - Maximum Speed (Standard - Boldface)	1.00" - 800 SPM 25mm - 800 SPM 1.25" - 700 SPM 32mm - 700 SPM 1.50" - 650 SPM 38mm - 650 SPM 2.00" - 500 SPM 50mm - 500 SPM 2.50" - 400 SPM 65mm - 400 SPM	1.00" - 600 SPM 25mm - 600 SPM 1.25" - 600 SPM 32mm - 600 SPM 1.50" - 550 SPM 38mm - 550 SPM 2.00" - 500 SPM 50mm - 500 SPM 2.50" - 400 SPM 65mm - 400 SPM	1.00" - 600 SPM 25mm - 600 SPM 1.25" - 550 SPM 32mm - 550 SPM 1.50" - 500 SPM 38mm - 500 SPM 2.00" - 450 SPM 50mm - 450 SPM 2.50" - 400 SPM 65mm - 400 SPM	1.25" - 550 SPM 32mm - 550 SPM 1.50" - 500 SPM 38mm - 500 SPM 2.00" - 400 SPM 50mm - 400 SPM 2.50" - 300 SPM 65mm - 300 SPM
A	Shutheight on Bolster (SDAU), Standard	15.00" 380 mm	14.88" 375 mm		17.00" 430 mm
	Slide Adjustment, Standard	5.0" 127 mm	5.0" 127 mm		5.0" 127 mm
B	Width of Bed, R-L	48" 1220 mm	60" 1525 mm	75" 1905 mm	84" 2134 mm
C x D	Area of Slide, R-L x F-B	48" x 20.5" 1220 x 520 mm	60" x 25" 1525 x 635 mm	75" x 25" 1905 x 635 mm	84" x 32" 2135 x 815 mm
B x E	Area of Bolster, R-L x F-B	48" x 32" 1220 x 815 mm	60" x 39" 1525 x 990 mm	75" x 39" 1905 x 990 mm	84" x 44" 2135 x 1120 mm
F x G	Maximum Opening Bed, R-L x F-B	41" x 13" 1040 x 330 mm	48" x 15" 1220 x 380 mm	63" x 15" 1600 x 380 mm	72" x 15" 1830 x 380 mm
H	Upright Opening, F-B	15" 380 mm	19" 485 mm		24" 610 mm
J	Distance Bottom of Foot to Top of Bolster	43" 1090 mm	55" 1395 mm		60" 1525 mm
K	Distance Bottom of Foot to Bottom of Bed	15" 380 mm	16" 405 mm		16" 405 mm
L	Bolster Thickness, Standard	5" 125 mm	7" 180 mm		8" 205 mm
M	Main Bearing Diameter	5.5" 140 mm	7" 180 mm		9" 230 mm
N	Approximate Overall Height (Standard Stroke & Shutheight)	172" 437 cm	211" 536 cm		214" 544 cm
P	Overall Width	126.0" 320 cm	143.0" 363 cm	158.0" 401 cm	172.0" 437 cm
Q x R	Area of Footprint, R-L x F-B	76.25" x 60" 1935 x 1525 mm	94.25" x 68" 2394 x 1725 mm	109.25" x 68" 2775 x 1725 mm	125" x 72" 3175 x 1830 mm
	Standard Feed Direction	L-R	L-R		L-R
	Upper Die Weight for Dynamic Balance (±50%)	500 Lbs. 227 kg	1,100 Lbs. 499 kg	1,800 Lbs. 816 kg	2,300 Lbs. 1043 kg
	Motor HP (For Maximum Speed)	40 Hp 30 Kw	50 Hp 37 Kw		60 Hp 45 Kw
	Press Weight	53,000 Lbs. 24,040 kg	90,000 Lbs. 40,825 kg	99,000 Lbs. 44,550 kg	117,000 Lbs. 53,070 kg
	Quick Lift Access	3" 76 mm	3" 76 mm		3" 76 mm

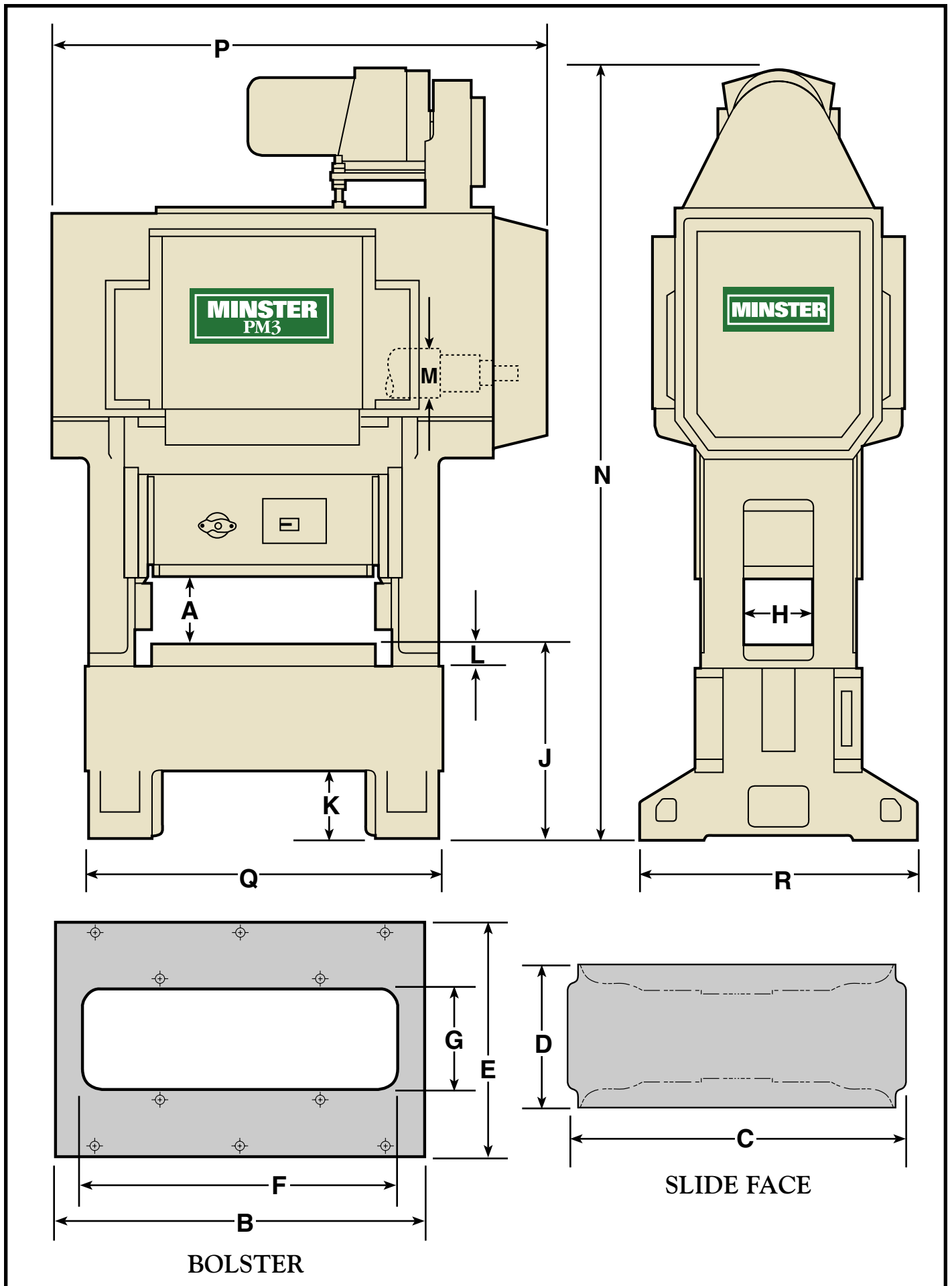



Let Minster supply your turnkey lamination system with such productivity enhancements as: Reels, Straighteners, Coil Cars, Die Carts, Thread Tables, Quick Die Change and Coil Welding. Call your Minster Representative or contact Minster direct.

Minster Keeps Pace With Changing Standards and Regulations

Presses shown, information, and references contained in this brochure, will not, in some cases, reflect latest recommendations of the ANSI B11.1 Standard, or certain Federal requirements as set down by the Occupational Safety and Health Act (OSHA). Illustrations of equipment are the most representative available at the time of publication of this literature. However, they may not depict design, required electrical controls, protective covers, etc., current at time of press shipment.

Press electrical controls, protective covers, etc., supplied on any MINSTER press will, at all times, meet The Minster Machine Company's interpretations of applicable ANSI or Federal Requirements at the time of that Press' shipment to

its original purchaser. Feed equipment covers are supplied by feed vendors to meet their interpretations of applicable ANSI Standards for press-mounted roll feeds.

Complete compliance with the regulations of the Occupational Safety Act, by law, rests with the machine tool purchaser. The Minster Machine Company does not either imply or warrant, under any circumstances, that safeguarding is furnished for the point of operation which the user installs in this press component. It is the user alone who can make proper determination of the safeguarding needed for his use of the equipment at the point of operation and from related hazards to the extent they may exist.



MINSTER®

THE MINSTER MACHINE COMPANY

240 WEST FIFTH STREET • MINSTER, OHIO 45865 U.S.A. • PHONE: (419) 628-2331 • FAX: 419-628-3517

www.minster.com

**Minster Has Sales and Service Offices Located Throughout the World
Contact Minster Direct For The Name of Your Global Representative**