



THE MINSTER MACHINE COMPANY



PM4 PIECEMAKER®

250-600 TONS CAPACITY

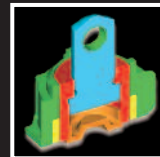

PM Series Presses

TECHNOLOGICALLY ADVANCED TO PROVIDE
GREATER FLEXIBILITY AND INCREASED PRODUCTION

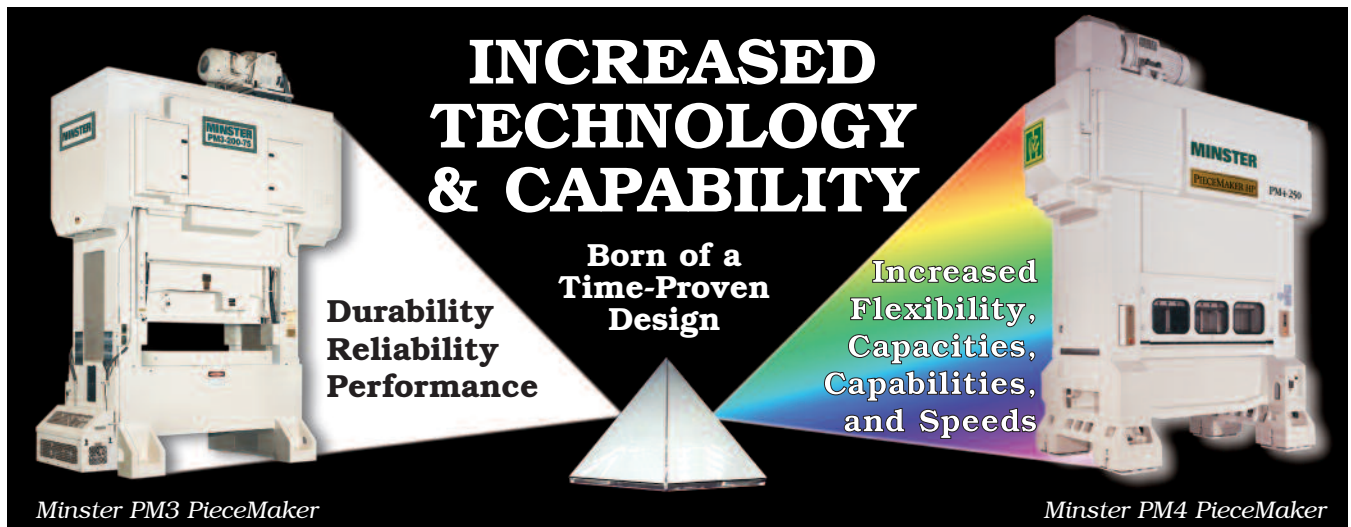

Born of the time-proven design of Minster PM3 Series presses comes the latest evolution in manufacturing and design technology ~ the PM4 Piece-Maker. Designed for today's high-speed lamination production requirements, the PM4 has been configured to provide increased energy while operating at higher speeds with larger upright openings and reduced deflections. The PM4 offers some of the most technologically advanced features in the material forming industry.

Minster Series PM4 presses provide the ultimate in consistent accuracy in automated high speed blanking operations in the 350 to 600 ton range.

Expensive lamination dies last longer in a Minster PM4 because of its unique design. The massive frame, full eccentric shaft with six main bearings, along with the heavy iron connections and massive steel wrist pins combine to provide a machine that is more stable at high lamination speeds with reduced punch penetration.

In-Die Staking

Unique features such as shutheight stabilization, massive wrist pins, a deep slide with long gib guiding, hydraulic quick lift slide and consistent slide bottom-dead-center repeatability make the PM4 the ideal press for in-die staking operations. Add to these features the adjustable-in-motion (A.I.M.) control and they provide accuracy so critical when staking laminations within the die, while at the same time promote increased die life and die accessibility.

Run Both Large and Small Dies on the Same Press

To give the user increased flexibility, the PM4 is designed to handle full tonnage dies that range from 50% to 100% of its die area. Refer to chart on page 4 for details. Dies even smaller than 50% of the die area can be run on the PM4 if they require less than full tonnage.

Run Progressive Dies With High Off-Center Loading

Hydrostatic gibbing is used to maintain the parallelism between the PM4 slide and bolster. When subjected to an off-center load, the pressure in the hydrostatic pads automatically adjusts to resist the off-center force. Refer to page 5.

Blank High Strength Material at Higher Speeds With Greater Uptime and Increased Die Life

A few of the unique features that provide this benefit on the PM4 include:

- A reverse load rating (2 to 4 times that of a standard press).
- Reduced punch penetration as a result of the overall rigidity of the PM4.
- Zero clearance slide adjustment screws as a result of a hydraulic locking mechanism.
- Utilization of high tensile cast iron which has over 3 times the dampening capability of steel to reduce the vibration in the tooling and extend tool life.

Inspect and Trouble-Shoot Dies and Release Jams Faster Without Adjusting Your Shutheight

The quick lift feature on the PM4 provides the operator with an additional 3" (75 mm) to inspect and trouble-shoot the die. In addition, this feature provides a quick method of releasing die jams, eliminating the need for hydraulic tie rod nuts.

002



003

STANDARD FEATURES

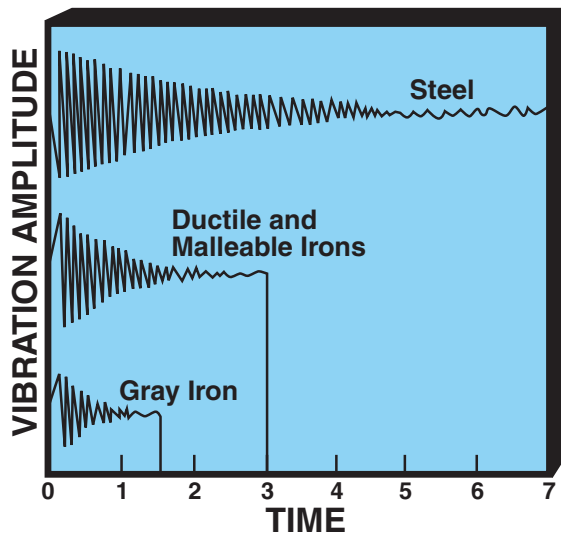
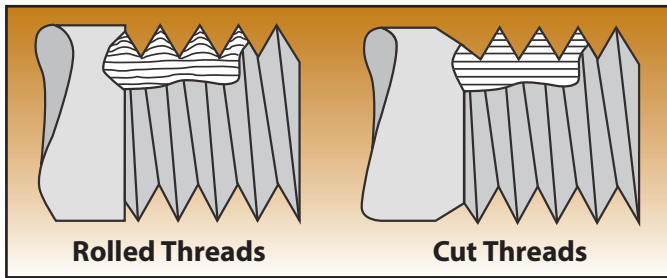

Iron has 2.5 to 4.5 times the dampening capability of steel. Therefore, the PM4 utilizes castings in all of its beds, slides and uprights to dampen vibration and noise created in high vibration and snap-thru applications.

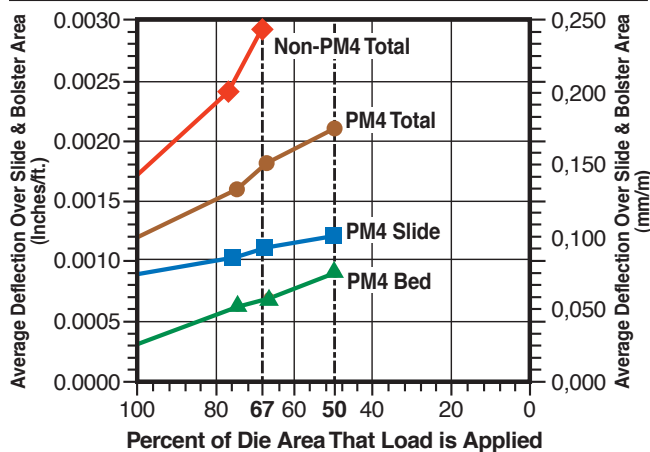
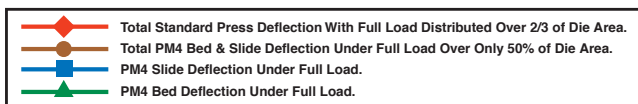

Massive Frame Construction

The PM4 boasts a massive four-piece, pre-loaded frame utilizing high tensile cast iron for the ultimate in vibration and noise dampening. The ultra-low deflection cast bed includes two double walls which reduce front-to-back deflections by 33% over industry standards for general purpose presses. This gives the user the flexibility to run small, full tonnage dies on a large press while maintaining part quality and extending die life.

All PM4 presses have large tie rod nuts with *rolled* threads. Rolled threads are capable of handling up to *three times the load* of standard cut threads. This added capability is essential in the event of an overload situation.

Lower Deflection & Greater Flexibility

Standard presses are designed to have a bed deflection of .0015" to .002" per foot (.125 to .167 mm/m) when full-rated tonnage is distributed over two-thirds of the bed. In addition, the slide deflection of a standard press will be approx. 1.5 times more than the bed deflection. As shown below, the PM4 has been designed with extremely low deflection providing the ability to run tighter punch-to-die clearance, as well as the flexibility to run small, full tonnage dies on a large press while maintaining part quality and die life.

Wide Upright Openings



Large upright openings allow feeding of wide material.

STANDARD FEATURES

Patented Minster Hydraulic Clutch and Brake Unit

Minster's combination hydraulic clutch and brake produces the maximum torque possible providing for faster starting and stopping. A patented segmented drive disc design provides safe and reliable operation, variable clutch torque and easy maintenance.

Segmented friction material allows for easy replacement without removal of the clutch and brake discs. In addition, Minster's clutch and brake unit requires no adjustment, resulting in less downtime and higher production rates.

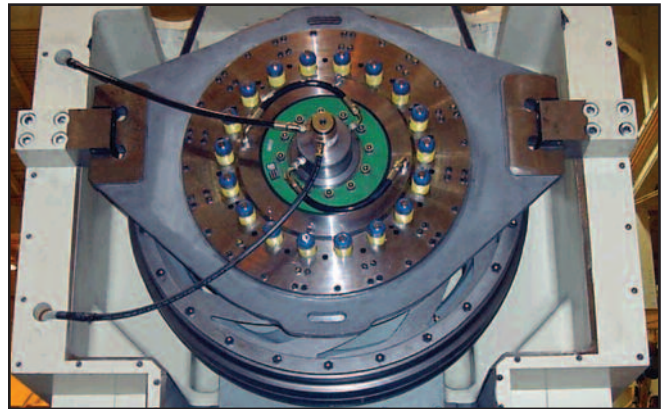

Eight-Point Hydrostatic/Hydrodynamic Gibbing For Precision Slide Guiding.

The PM4 slide guiding system incorporates both hydrostatic and hydrodynamic bearing technology. This combination of technologies provides:

- Greater resistance to off-center loading than either standard oil film or roller bearing guided gibs.
- Extreme overload capacity for shock loading.
- Centering of slide in a static condition.

Hydrostatic Gib Monitoring

This system will top stop the press if the gibs' clearance is closed-in due to a set up problem or other issue. The hydrostatic gib monitoring system is comprised of twelve pressure transducers positioned in the lubrication circuit to sense the gib clearance on both the main and auxiliary gibs.



Stopping Angle vs. SPM ~ PM4-350 With 1.18" (30 mm) Stroke

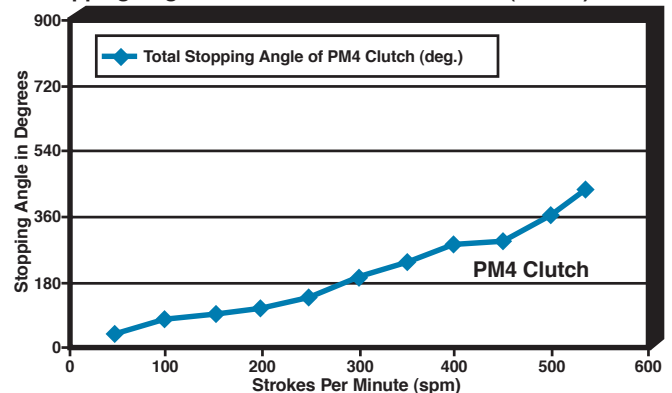

The Minster combination hydraulic clutch and brake provides the ability to single stroke at high rates while simultaneously providing unparalleled stopping time ability that is critical for high speed and in-die sensing applications.

The Basics of Hydrostatic/Hydrodynamic Technology

Twelve, separate, hydrostatic pads are machined into the extra-wide gib surfaces of the PM4. When an off-center force attempts to tip the slide, the oil pressures at these pads change independently to offset the force and maintain exceptional slide parallelism.

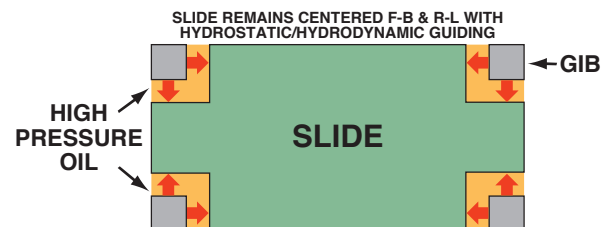

005

STANDARD FEATURES

Full Wrist Pins

Full wrist pins, supplied with high-pressure oil, provide superior snap-thru ratings with reduced wear and deflection. The high tensile stiffness of this design results in improved bottom- dead-center repeatability along with reduced die punch penetration which are critical during high tensile blanking operations. In a snap-thru condition, a wrist pin is subjected to pure shear forces while the connection is only subjected to simple tension forces. Comparatively, when a ball and socket design is subjected to snap-thru, in addition to the shear and tension forces, the ball bushing and retainer are also subjected to bending moments which create a more severe stress situation.

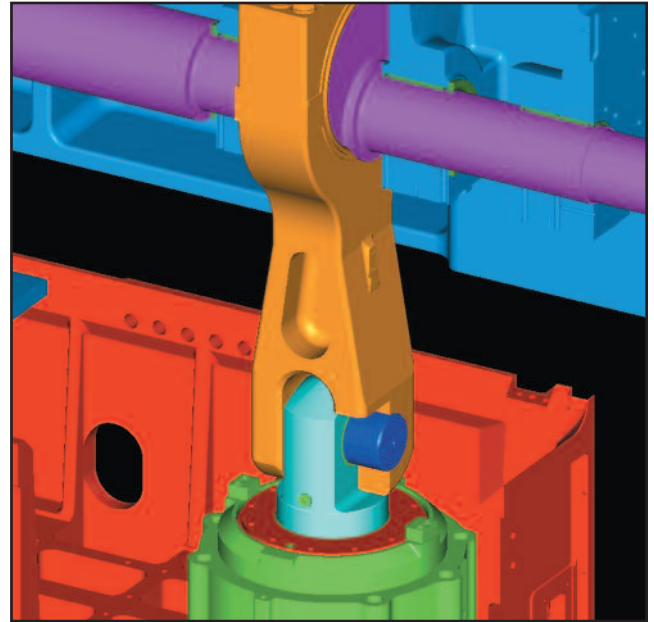

Eccentric Shaft

The throw-to-throw accuracy of Minster's one-piece forged eccentric shaft is within $\pm .0005"$ ($.0127$ mm) to provide superior dynamic parallelism that results in increased die life in close tolerance dies. Eccentric shafts provide more accuracy and higher rigidity than eccentric gears or crank-shafts, and they have approximately 33% more load bearing area and less deflection than a standard crankshaft. This design significantly increases the press's ability to handle snap-thru forces as compared to a crankshaft or eccentric gear design.

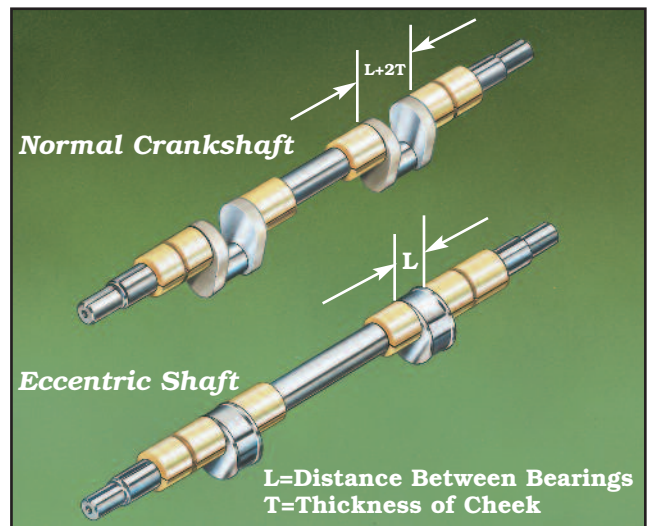

Reverse Load Rating

The combination of the PM4's hydrodynamic drive bearings, forged eccentric shaft, heavy ductile connections, full wrist pins, and slide adjustment screws with hydraulic locked buttress threads, provide the PM4 with a reverse load rating 2 to 4 times that of standard presses. This high rating minimizes punch penetration and provides increased capability for blanking and piercing applications.

Hydrodynamic Drive Bearings

Advantages of Hydrodynamic Bearings:

- Indefinitely long life with full film lubrication.
- High load capacity
- Load capacity and stiffness increase w/speed.
- Extreme overload capacity for shock loading.
- High vibration dampening.
- Replacement involves only limited disassembly.

Roller Bearing Weaknesses:

- Statistically predictable limited life.
- Shock load capacity no greater than static load capacity.
- Severe overloads produce brinelling.
- Replacement involves extreme disassembly.

006

STANDARD FEATURES

Quick Access Feature

The Quick Access feature on Minster PM4 presses enables easy access to the die.

Advantages of this feature include:

- Allows the user to raise the slide 3" (75mm) providing quick and easy access to thread material, inspect the die or release material.
- Eliminates the need for hydraulic tie rod nuts.
- After use, mechanical stops ensure the slide is returned to the exact shutheight

position and parallelism that it maintained prior to use. This is not possible with a screw-type mechanism.

- Allows the user to select a press the minimum stroke length for the application without sacrificing the operator's ability to inspect or change tooling. Utilizing a shorter stroke length minimizes the slide velocity resulting in reduced impact loading, reduced tool vibration, increased tool life and increased production speeds.
- The pressurized quick lift chamber provides a preload exceeding the press tonnage.

Hydraulic Locking

Clearance in the slide adjustment screw and nut mechanism are eliminated by compression of the nut diameter with high pressure oil. This reduces vibrations resulting from snap-thru forces during blanking, improves die life, and eliminates the possibility of the slide adjustment "creeping" under load.

Motorized Slide Adjustment

The slide adjustment on the PM4 is driven by a hydraulic motor connected to hardened worm shafts with zero backlash couplings and is supported on anti-friction bearings. The adjustment mechanism includes a shock mounted electronic resolver to display and adjust shutheight on the press console.

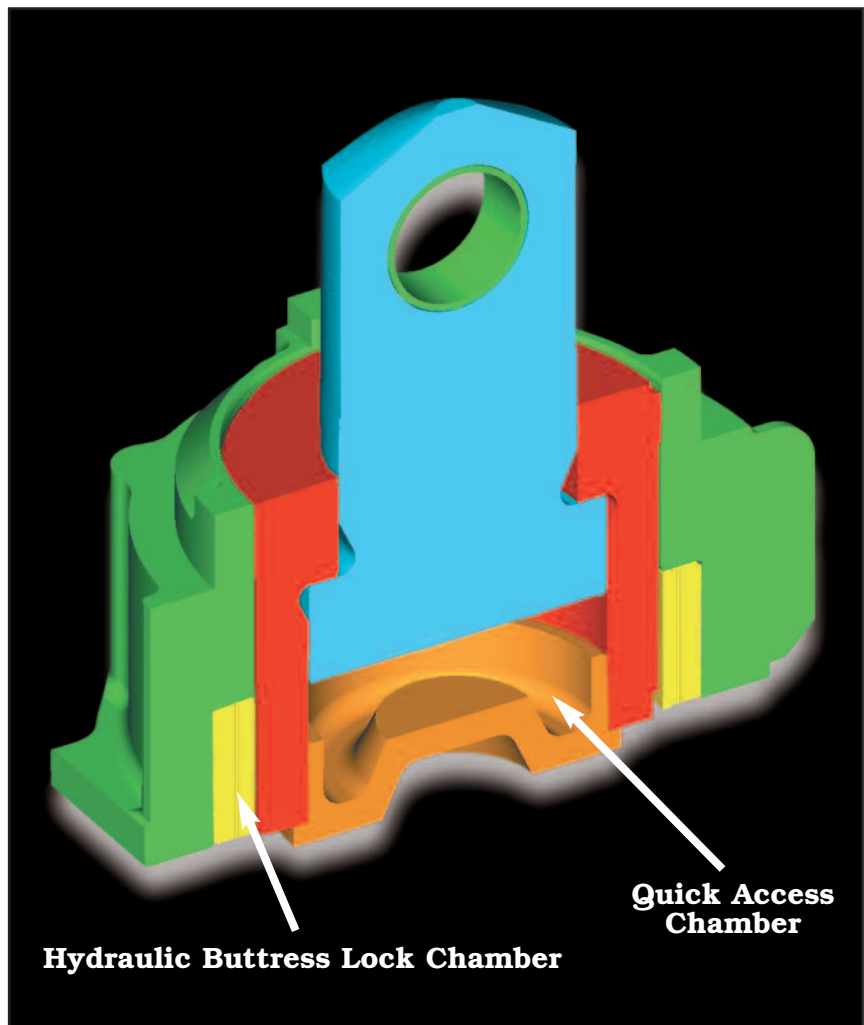

007

STANDARD FEATURES

Flywheel Drive Arrangement For Maximum Efficiency

The Minster PM4 Series presses are **flywheel** type presses running at higher speeds for punching, notching, and blanking operations on lamination materials. The clutch and brake unit is mounted on the eccentric shaft and the flywheel rotates on anti-friction bearings.

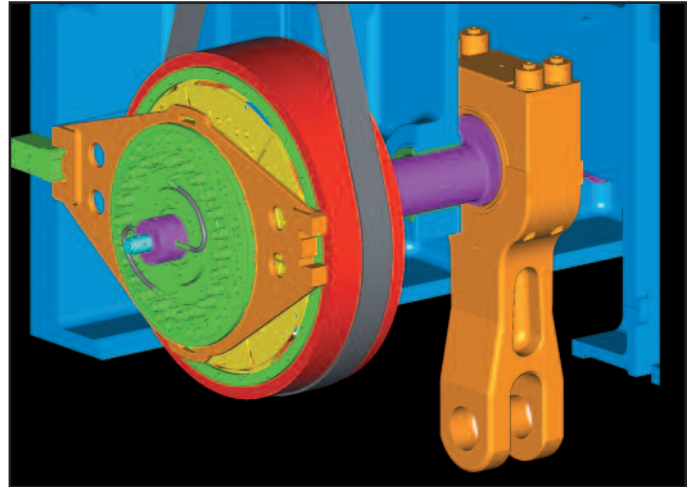

Monitored Lubrication With Variable Frequency Regulation

All main and connection bearings have full film lubrication with pressurized oil supplied to each bearing from within the crankshaft. This system is designed to stop the press in the event of reduced oil pressure thereby preventing damage to the machine. A variable speed lube pump motor with pressure transducer feedback maintains constant oil pressure through plant ambient and press temperature variations. The consistent oil film gives the ultimate dynamic bearing stiffness and longevity resulting in better bottom-dead-center repeatability and longer die life.

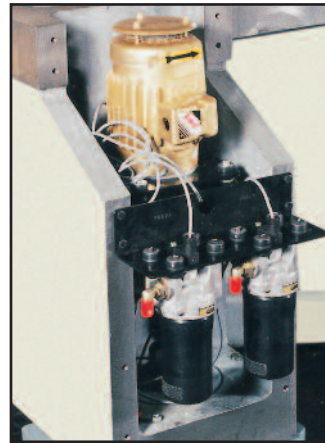

Lube Pump

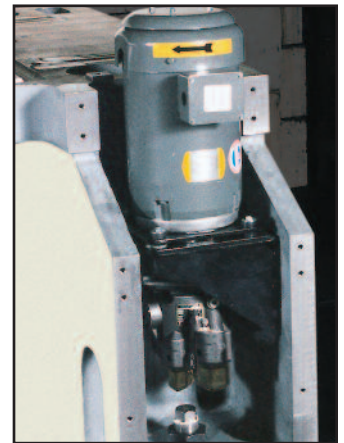

Hydraulic Pump

Drive Motor

The PM4 variable frequency main drive motor is totally enclosed, fan cooled, variable speed and provides proven durability and increased torque response to offer these benefits:

- Simplified control unit for easy troubleshooting.
- Interchangeable controller.
- Belt pull will not affect internal motor bearings.

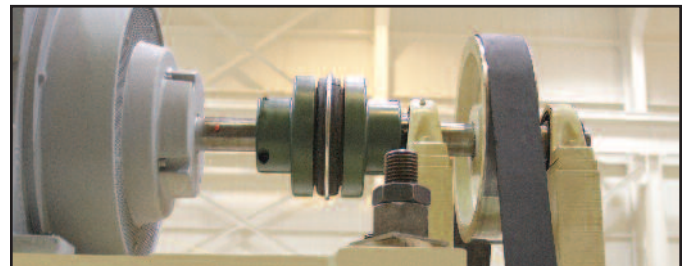

Isolation/spring mounts are included and built in as standard on Minster PM4 presses.



008

STANDARD FEATURES

Flywheel Brake

The flywheel brake design on the Minster PM4 gives the operator the ability to quickly slow the flywheel to a pre-set speed. The combination of an increased brake contact area, reduced surface contact pressure, and increased useable lining thickness provides 7 to 10 times the life of a normal brake lining.

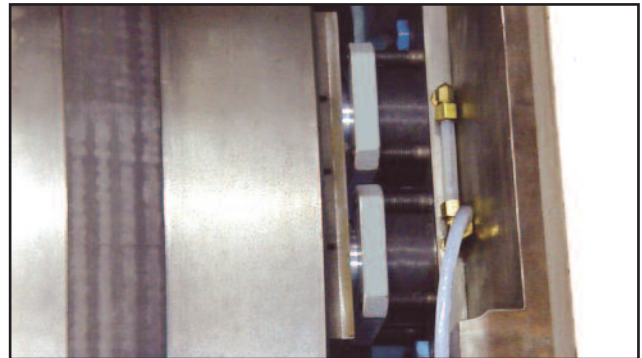

Dynamic Balancing

The Dynamic Balancing System on the PM4 greatly reduces the effect of the slide inertia forces caused by running at high speeds. This reciprocating balancer helps maintain precise slide bottom-dead-center repeatability resulting in less die wear and greater part accuracy. It also allows the press to run at higher speeds and reduces press vibration.

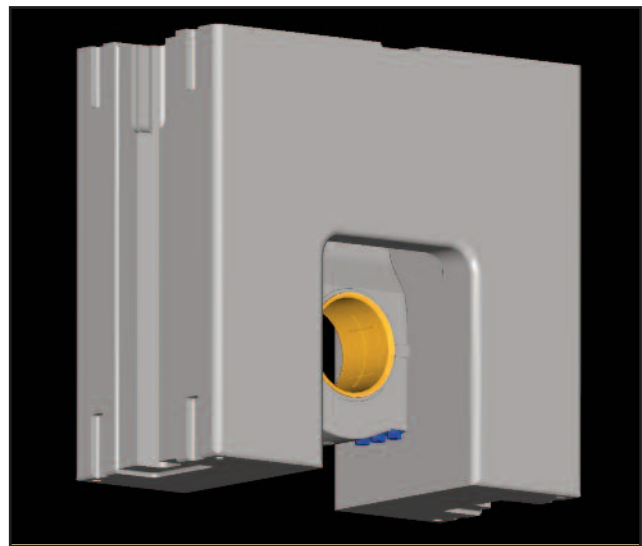

PM4 Dynamic Balancer

Die Guarding



Crankshaft Extension

Minster provides as standard, one crankshaft extension on the opposite drive side of the PM4. This extension is available to drive the user's auxiliary equipment such as feeds, scrap cutters, or mechanical die indexers.

Electrical Standard Features

- Minster PMC Control (See page 10)
- Control Pedestal Located on Feed Side
- Pedestal-Mounted Control Station
- Pedestal-Mounted Run Station
- Press Stop Control Buttons Mounted on Each Upright
- (2) Press Top Stop Control Buttons (One each on front and rear)
- 16-Pole Programmable Limit Switch
- Non-Reversing Drive Motor Starter

ELECTRICAL STANDARD FEATURES

Minster Production Management Control (PMC)

This full featured press control was designed and integrated by Minster and incorporates all press functions including:

- Full machine diagnostics detailing all press and feed line faults.
- Selectable supervisor lockout for each function.
- Clutch/Brake start-stop.
- Motor controls.
- Tool storage.
- Energy saver mode.
- Preventative maintenance monitoring.
- Programmable Limit Switch.
- Counters.
- Stopping time indicator.
- Reason for recent stop.
- Crank position indicator including distance off bottom.

The PMC utilizes open architecture which allows for greater convenience in planning and maintenance. It incorporates a PLC and color touch screen technology; and, all press and feed line functions can be monitored for efficient diagnosis of production line faults.



This option provides detailed monitoring of press room production equipment from remote locations and uses the industry standard network and database infrastructure. With an ethernet-based local area network and available Internet connectivity, the open architecture allows for integration into non-PMC type control systems. The relational database allows for easy migration of data to other systems/applications. Feature views include: press summary; press detail; tool storage; production history; fault history; production efficiency; revenue reports; load history; vibration history; dial-up access and support; HTML help, etc.



Available Popular Options:

- Additional tool storage.
- Die protection with Auto tune technology.
- Load Monitoring
- Automatic shutheight and adjust-in-motion control.



010

OPTIONAL FEATURES

Eddy Current Drives

The PM4 is available with either a variable frequency drive, or an eddy current type speed drive.

Adjust-In-Motion

- Allows micro-adjustment while running.
- Accurate change feedback
- Helps maintain bottom-dead-center repeatability.

Coil Line Interconnects

Additional Part Blow-Off Valve

Automatic Shutheight Adjustment

Will automatically set the shutheight to the predetermined tool storage value, reducing setup time.

Manual shutheight adjustment can still be achieved via the operator's input on the control.



- Rotors
- Stators
- Transformer Laminations

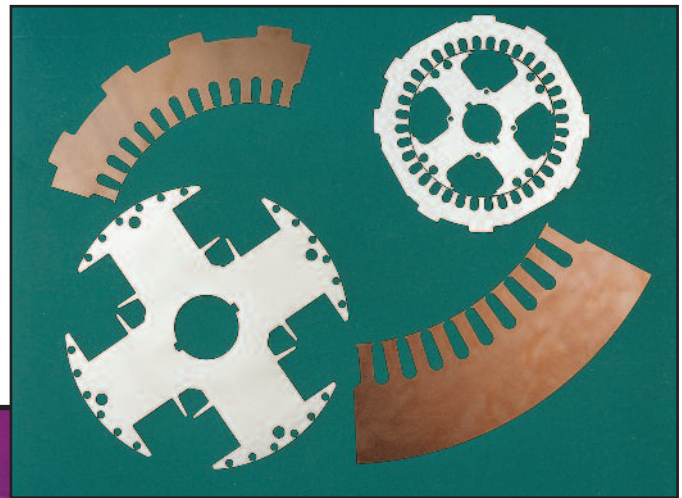

- Segmented Laminations



- Segments, Loose or Staked Laminations

011

SPECIFICATIONS & DIMENSIONS

| | Press Size | PM4-250 | | PM4-350 | | PM4-450 | | PM4-600 | |
|-----|---|--|-----------------|--|-----------------|--|-----------------|--|------------|
| | Drive Type | Flywheel Drive | | Flywheel Drive | | Flywheel Drive | | Flywheel Drive | |
| | Tons Capacity | 250 @ .063 Off Bottom 2225 kN @ 1,6mm Off Bottom | | 350 @ .063 Off Bottom 3100 kN @ 1,6mm Off Bottom | | 450 @ .063 Off Bottom 4000 kN @ 1,6mm Off Bottom | | 600 @ .063 Off Bottom 5400 Kn @ 1,6mm Off Bottom | |
| | Slide Stroke vs. Speed | Stroke | Max. Speed | Stroke | Max. Speed | Stroke | Max. Speed | Stroke | Max. Speed |
| | | 1.18" 30 mm | 100-535 | 1.18" 30 mm | 100-525 | 1.18" 30 mm | 100-450 | 1.18" 30 mm | 90-350 |
| | | 1.38" 35 mm | 100-490 | 1.38" 35 mm | 100-475 | 1.38" 35 mm | 100-400 | 1.38" 35 mm | 90-300 |
| | | 1.57" 40 mm | 100-450 | 1.57" 40 mm | 100-425 | 1.57" 40 mm | 100-375 | 1.57" 40 mm | 90-275 |
| | Quick Access Slide Travel | 2.95" 75 mm | | 2.95" 75 mm | | 2.95" 75 mm | | 2.95" 75 mm | |
| E | Upright Opening | 27.50" 700 mm | | 27.50" 700 mm | | 41.50" 1050 mm | | 47.50" 1200 mm | |
| KxL | Area of Bolster & Slide (R-L x F-B) | 86.6 x 43.3" 2200 x 1100 mm | | 86.6 x 47.5" 2200 x 1205 mm | | 100.5 x 55.1" 2555 x 1400 mm | | 120.0 x 59.0" 3050 x 1500 mm | |
| | | | | 120.0 x 47.5"* 3050 x 1205 mm | | 120.0 x 55.1"* 3050 x 1400 mm | | | |
| MxN | Opening in Bolster (R-L x F-B) | 74.8 x 15.0" 1900 x 380 mm | | 74.8 x 15.0" 1900 x 380 mm | | 86.6 x 18.5" 2250 x 470 mm | | 108.25 x 20.5" 2750 x 520 mm | |
| | | | | 108.2 x 15.0" 2750 x 380 mm | | 106.2 x 18.5" 2700 x 470 mm | | | |
| | Opening in Bed (R-L x F-B) | 77.0 x 15.0" 1850 x 380 mm | | 77.0 x 15.0" 1950 x 380 mm | | 90.6 x 20.5" 2300 x 520 mm | | 110.25 x 22.5" 2800 x 570 mm | |
| | | 110.2 x 15.0" 2800 x 380 mm | | 110.2 x 15.0" 2800 x 380 mm | | 110.2 x 20.5" 2800 x 520 mm | | | |
| | Flywheel Energy | 22 In. Tons @ 100 SPM .063" (1,6mm) Off Bottom | | 22 In. Tons @ 100 SPM .063" (1,6mm) Off Bottom | | 28 In. Tons @ 75 SPM .063" (1,6mm) Off Bottom | | 38 In. Tons @ 65 SPM .063" (1,6mm) Off Bottom | |
| | Max. Upper Die Weight | 2200 Lbs. 1000 kg | | 2200 Lbs. 1000 kg | | 2640 Lbs. 1200 kg | | 4840 Lbs. 2200 kg | |
| | Main Bearing Diameter | 8.5" 215 mm | | 8.5" 215 mm | | 9.5" 240 mm | | 11.0" 280 mm | |
| A | Shutheight Range On Bolster (S.D.A.U.) | 10.83 to 17.72" | 14.76 to 21.65" | 10.83 to 17.72" | 14.76 to 21.65" | 10.83 to 18.70" | 14.76 to 22.64" | 13.0 to 23.23" | |
| | | 275 to 450 mm | 375 to 550 mm | 275 to 450 mm | 375 to 550 mm | 275 to 475 mm | 375 to 575 mm | 330 to 590 mm | |
| B | Shutheight Adjustment | 6.88" 175 mm | | 6.88" 175 mm | | 7.87" 200 mm | | 10.25" 260 mm | |
| C | Bolster Thickness | 7.09" 180 mm | | 7.09" 180 mm | | 7.87" 200 mm | | 9.06" 230 mm | |
| D | Floor to Top of Bed (With Spring Mounts) | 61.0" 1550 mm | | 61.0" 1550 mm | | 77.0" 1955 mm | | 82.0" 2085 mm | |
| J | Bed Clearance to Floor (With Spring Mounts) | 23.0" 585 mm | | 23.0" 585 mm | | 33.0" 840 mm | | 31.0" 785 mm | |
| F | Overall Height (With Spring Mounts) | 235" | 239" | 235" | 239" | 282" | 286" | 307" | |
| | | 5970 mm | 6070 mm | 5970 mm | 6070 mm | 7150 mm | 7250 mm | 7800 | |
| G | Floor Space (R-L) | 138.0" 3505 mm | | 138.0" 3505 mm | | 161.0" 4090 mm | | 181.0" 4595 mm | |
| H | Floor Space (F-B) | 95.0" 2415 mm | | 95.0" 2415 mm | | 108.3" 2750 mm | | 122.0" 3100 mm | |
| | Approximate Weight | 151,000 Lbs. 68,500 kg | | 151,000 Lbs. 68,500 kg | | 265,000 Lbs. 120,200 kg | | 350,000 Lbs. 158,800 kg | |
| | | | | 171,000 Lbs. 78,000 kg | | 295,000 Lbs. 129,500 kg | | | |

* NOTE: Consult Minster For Speed Ranges.

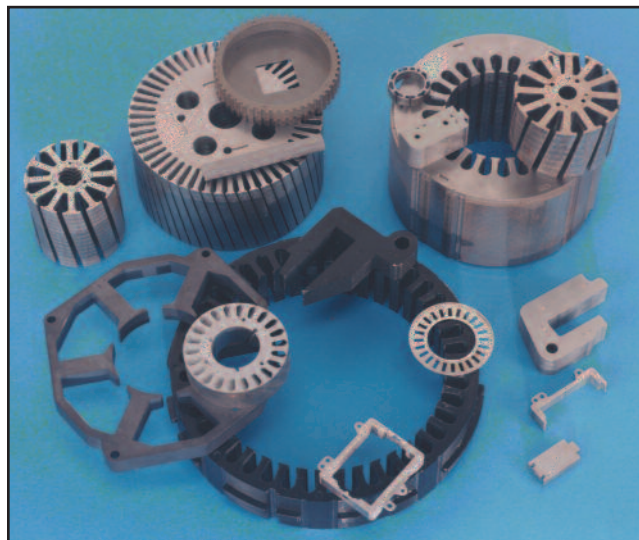
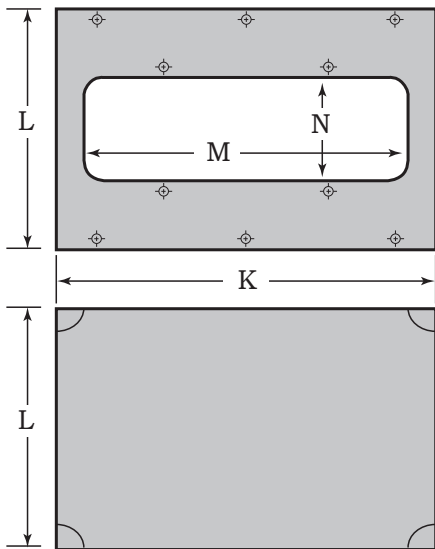
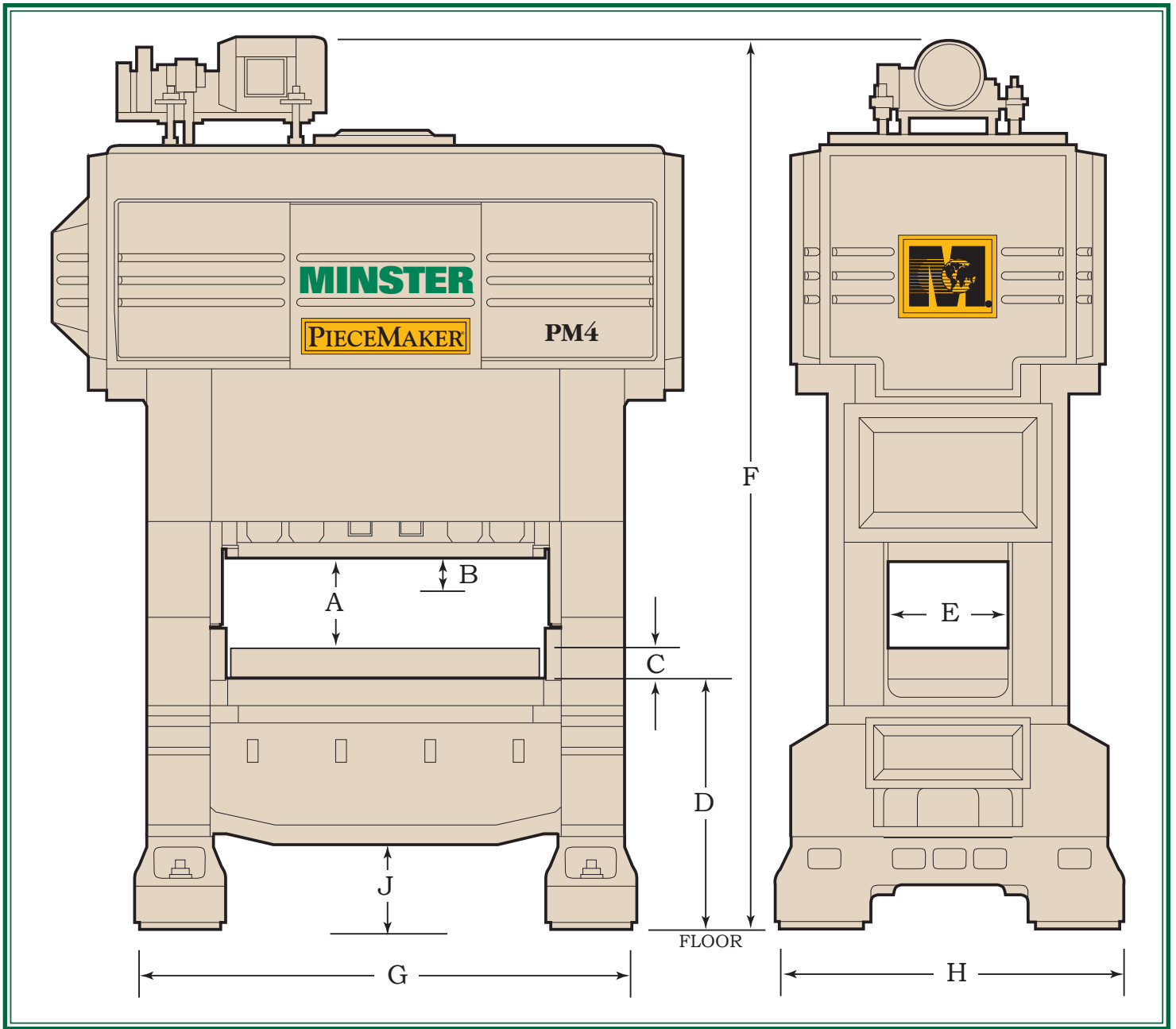

013



The Minster Machine Company, Minster OH



The Minster Machine Company, Beaufort, SC



The Minster Machine Company, Halblech, Germany
Telephone: (49) 8368 9134 0

Before You Invest in New Material Forming Technology, You're Invited to Visit Our Manufacturing, Training, Research, Parts and Service Facilities to See How "Minster Quality" is Built Into All of Our Products and Services.



MINSTER®

THE MINSTER MACHINE COMPANY

A Century of Heritage Pressed Into a Lifetime of Quality

240 WEST FIFTH STREET • MINSTER, OHIO 45865-0120 U.S.A. • PHONE: (419) 628-2331 • FAX: 419-628-3517

www.minster.com

Minster Has Sales and Service Offices Located Throughout the World
Contact Minster Direct For The Name of Your Global Representative