

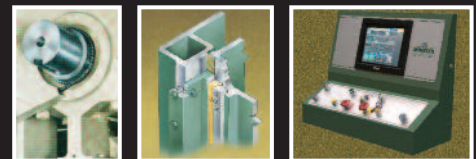

# P2

## PIECE-MAKER

60-200 TONS CAPACITY



### *P2 Series Presses*

HIGH PERFORMANCE COMBINED WITH DURABILITY RELIABILITY  
AND SERVICEABILITY IN STRAIGHT SIDE PRECISION PRESSES

# INTRO

## Automatic Straight Side Presses

*Every operation involved in the building of a Minster Piece-Maker® press, from pouring of castings to final inspection, is based upon the determination to build the finest precision press. Because of this tradition, a Minster Piece-Maker gives superior performance, greater accuracy, higher production and longer die life, even under the most severe operating conditions.*



*Parallelism between bolster and slide face is checked to determine that the precision alignment required on Piece-Maker presses has been maintained throughout all stages of construction. Also, vertical angularity of the slide throughout its entire stroke is checked left to right and front to back. This kind of built-in quality is responsible for precision die alignment so necessary for successful progressive die stamping.*

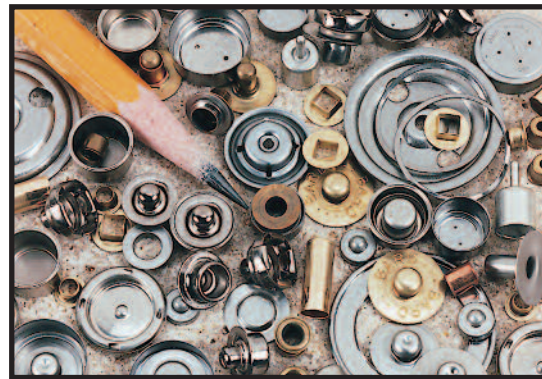

002

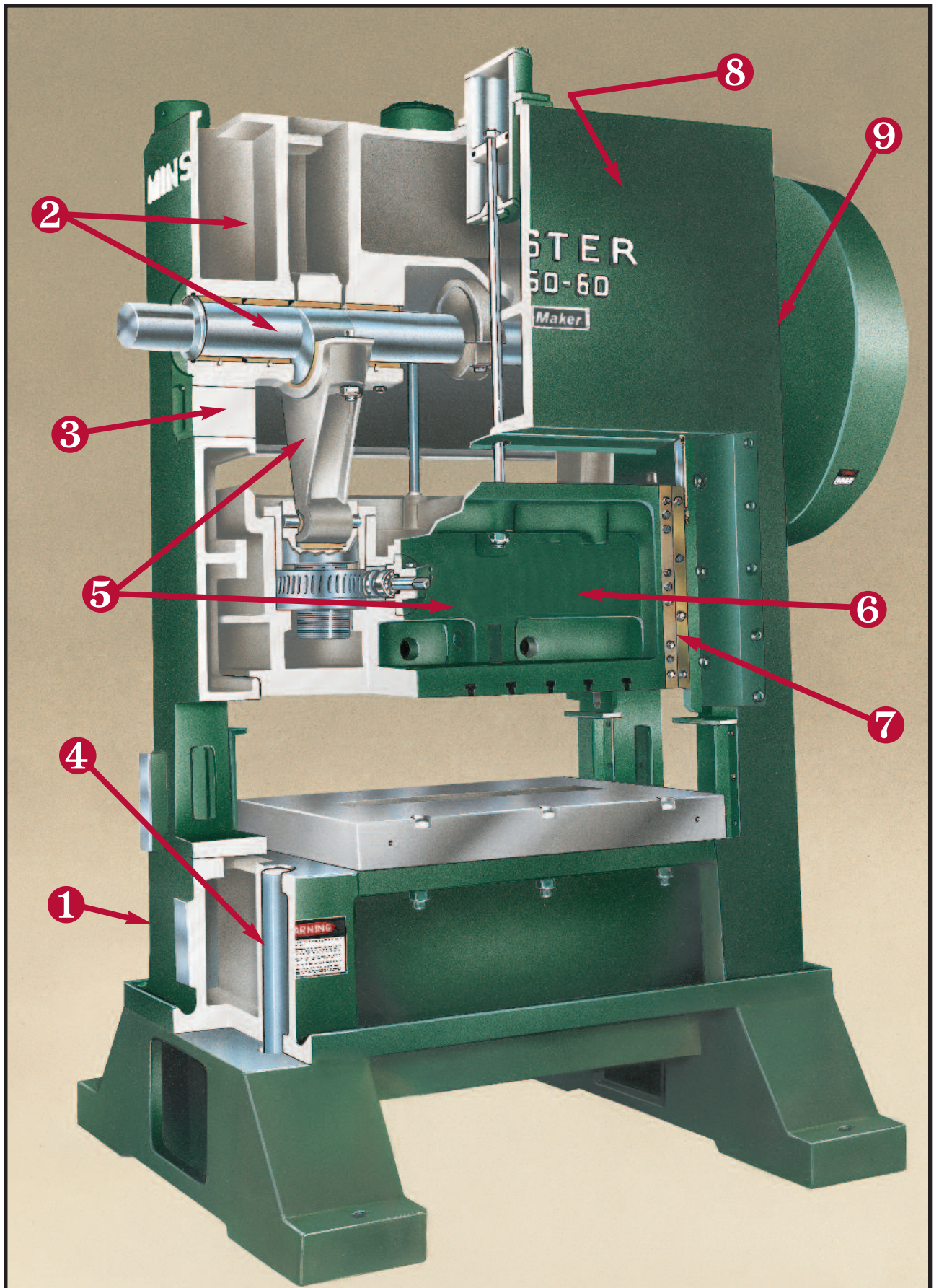

003

# STANDARD FEATURES

## Cast Construction Reduces Vibration. ①

Minster *Piece-Maker* P2 Series automatic production presses are of high tensile cast iron construction. Parts sections are properly proportioned for greatest strength without internal stresses. Various alloys are used for different cast parts depending upon their function. Minster's cast construction is highly efficient in providing the compressive strength and vibration dampening requirements so essential in building a precision press for progressive die work -- particularly on heavy blanking jobs having high fracture loads. You get less punch wear, better die life and more part accuracy because the vibration is held to a minimum in a Minster *Piece-Maker*.

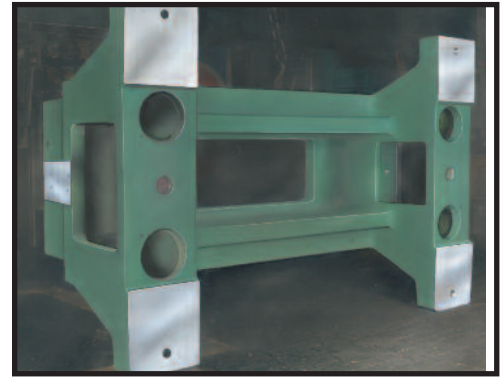

## Massive Bed Has Exceptional Rigidity. ①

The superior design and quality construction of the P2 bed gives it the lowest possible deflection characteristics under constant impact and heavy load conditions to maximize tool life and part quality. Oil troughs help contain die lubricants for recycling.

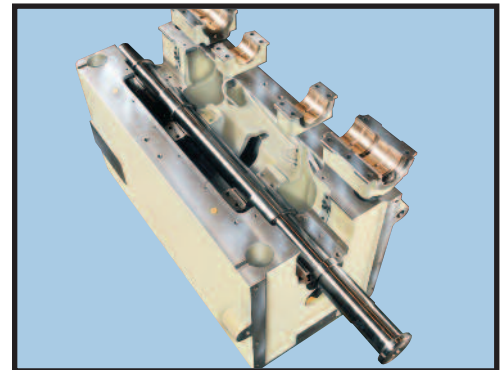

## Crown and Eccentric Shaft Provide Strength and Resist Deflection. ②

The massive crown of the Minster *Piece-Maker* is engineered to maximize die life and part quality. Deep crown design backs up the eccentric shaft at any angle against forces created by the stamping application. Close-coupled load carrying plates evenly distribute these forces into the crown structure.

The forged steel eccentric shaft resists torsional and bending deflection to enhance die parallelism. It is machined to a superb finish for excellent bearing fits and reduced stresses. The eccentric shaft eliminates the unsupported areas between main and connection bearings caused by the cheek thickness of the normal crankshaft. P2's come standard with one extension.

The main bearings of the P2 press give exceptional support to the eccentric shaft. Bearings are line bored for precise alignment. Crankshaft counterweights are standard on all flywheel drive P2's.

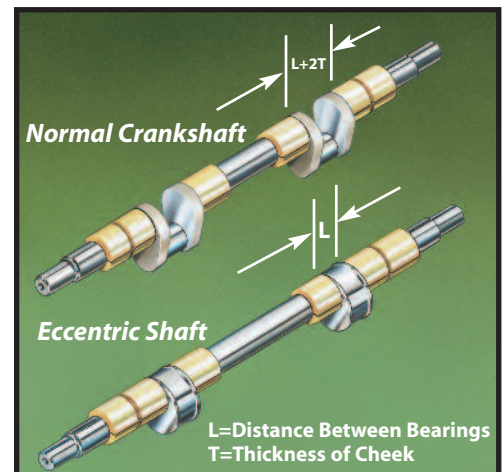

## Main Bearing Support Block. ③

This wedge-type support block is precision fitted between the main bearing caps and the top of the uprights. These supports help relieve the stresses placed on bearing cap screws by snap-thru forces and add to die life by stabilizing punch penetration.

## Tie Rods Aid Rigidity. ④

Four-piece tie rod construction is used in all Minster P2 frames. Massive steel tie rods are pre-stressed to solidly hold the frame against off-center loading from progressive dies.

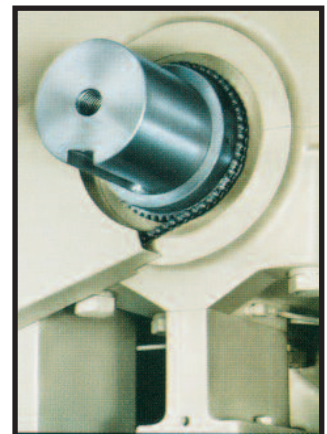
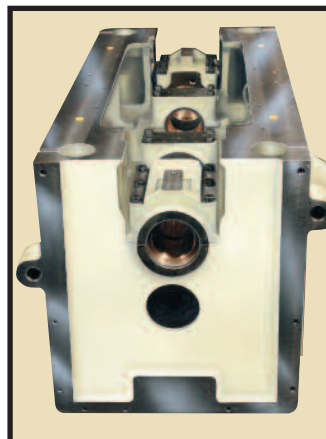

# STANDARD FEATURES

## Heavy Slide and Connections. 5

The P2 slide is of deep, heavily reinforced box-type construction, designed to withstand deflection to promote part quality and provide a large die area within the gibs. The massive upper connections easily transmit pressure through the working stroke. Lower connections have removable bronze saddle bushings. All P2 slides are arranged for one cross bar knockout as standard.

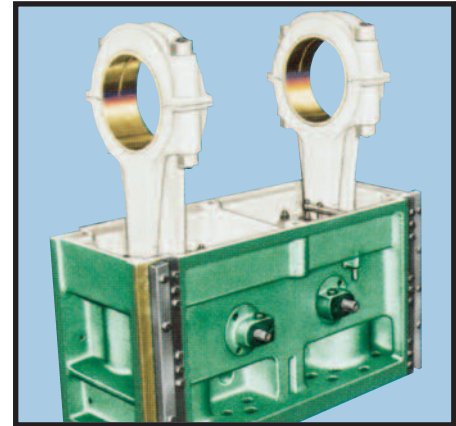

## Shutheight Adjustment & Indication. 6

Included as standard is an electronic encoder mounted on the slide that sends a digital readout to the PMC display. This feature aids the operator in accurate die setting procedures. The P2 offers powered slide adjustment for operator ease.

PRESS SIZE SLIDE ADJUSTMENT METHOD	P2-60	P2-100		P2-150		P2-200	
	Flywheel	Flywheel	Geared	Flywheel	Geared	Flywheel	Geared
Arranged for Detachable Air Wrench	STD.	STD.	STD.	Option	Option	Option	Option
Built-In ELECTRIC Motorized	N/A	Option	Option	STD.	STD.	STD.	STD.
Double Lock-Up w/Manual Adjustment	Option	Option	N/A	Option	N/A	Option	N/A

## 8-Point Gibbing for Precision Slide Guiding. 7

Precision slide guiding is maintained by the close-tolerance 8-point gibbing arrangement. Front and rear gibs are accurately squared with the press bed and set for proper clearance by laminated spacers under each main gib bolt ... thus eliminating trial and error adjustment.

Front to back ways have fixed bronze wear plates, machined square with the slide face. Left to right ways are adjusted and supported their full length by tapered back-up bars. The extra-long gibs guide the slide fully within the gibs throughout the stroke -- even at maximum shutheight adjustments. This assures excellent slide-to-bed parallelism at all times, contributing to clean material fracture, high part accuracy, and increased die life. Slide and bolster are machined with standard T-Slots.

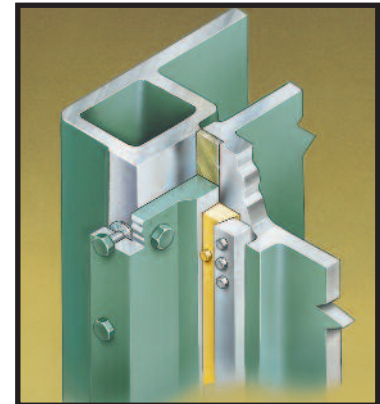

## Drive Arrangements for Maximum Press Efficiency. 8

**Flywheel** type presses run at higher speeds and have shorter strokes for punching, notching, blanking and shallow forming or drawing operations on lighter materials. The Clutch and Brake Unit is mounted on the eccentric shaft within the flywheel. Flywheel rotates on anti-friction bearings. Flywheel brake is electrically interlocked with drive "Stop" circuit to eliminate "coasting."

**Single Geared** P2 presses incorporate helical gears for quiet operation, heavier material blanking, punching and deeper forming or drawing operations. The Clutch and Brake Unit is mounted on the eccentric shaft within the main drive gear which rotates on anti-friction bearings. This arrangement provides a wider than normal speed range for a geared press.

All Minster P2 presses use a variable frequency drive motor for long life and easy operator adjustment.



Geared Drive Motor is on rear as shown.

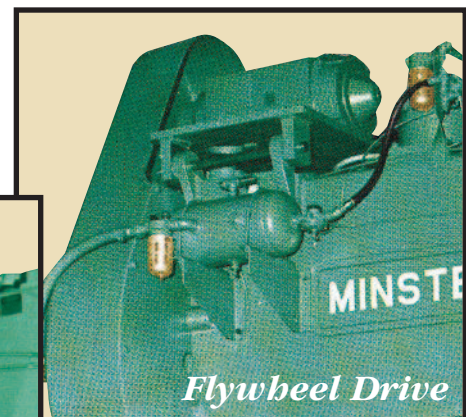

005

## MINSTER® MonitorFlow ... Continuous, Monitored Press Lubrication.

The patented Minster MonitorFlow Pressurized Recirculating Oil Lubrication System supplies a continuous flow of filtered oil under pressure to **all** bearing surfaces ensuring reliable operation. It monitors both the flow to these points as well as oil level and pressure in the entire system. If a fault occurs, it protects the bearings by stopping the press operation before damage happens.

From the **Manifold** in the press crown, oil is channeled to bearings, gibs, gears, and counterbalances. Flow switches here monitor oil flow to main and connection bearings and through sump line to reservoir. This protects against either broken or plugged lines.

In the event of a lubrication fault, the **Global Message Screen** within the control instantly indicates which flow switch (or switches) signalled the fault, helping to pinpoint the problem area.

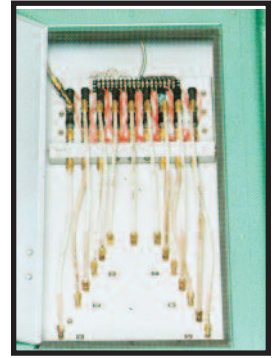

## Minster Combination Air Friction Clutch and Brake Increases Die Life and Parts Production. 9

This **Single Unit, Automatically Synchronized**, combination, multiple disc clutch and brake has one moving member engaging the clutch by air pressure or applying the brake by spring pressure. Movement from full brake to complete engagement is approximately 1/16" assuring quick, controlled stopping at any speed. Engagement on 360° friction surfaces remains constant throughout the stroke eliminating backlash after stamping and on the upstroke.

**Clutch Bumping Arrangement** and **Power Off Flywheel Barring** are standard on flywheel type presses 100 tons and smaller.

### Mechanical Options:

- Bolster Machining and Precision T-Slots.
- Crossbar Knockout Parts.
- Detachable Air Slide Adjustment Wrench.
- Press Mounts.
- Die Cushions.
- Die Safety Block.
- Special Paint.

## Standard Electrical Features

### Production Management Control (PMC)

This full featured press control was designed and integrated by Minster and incorporates all press functions including:

- Full machine diagnostics detailing all press & feed line faults.
- Selectable supervisor lockout for each function.
- Clutch/Brake start-stop.
- Motor controls.
- Tool storage.
- Energy saver mode.
- Preventative maintenance monitoring.
- Programmable Limit Switch.
- Counters.
- Stopping time indicator.
- Reason for recent stop.
- Crank position indicator including distance off bottom.



The PMC utilizes open architecture which allows for greater convenience in planning and maintenance. It incorporates a PLC and color touch screen technology; and, all press and feed line functions can be monitored for efficient diagnosis of production line faults.



### Available popular options include:

- Additional tool storage.
- Die protection with Auto Tune technology.
- Load Monitoring.
- Automatic shutheight and counterbalance control.

# Minster Series P2 Specifications & Dimensions

(All Dimensions in Metric)

Dimen.	PRESS SIZE	P2-60		P2-100		P2-150		P2-200	
		Flywheel Type	Flywheel Type	Single Geared	Flywheel Type	Single Geared	Flywheel Type	Single Geared	
	<b>DIMENSIONS COMMON TO ALL WIDTHS</b>								
	Tons Capacity at Bottom of Stroke	550 kN	910 kN		1350 kN		1800 kN		
	Crankshaft Dia. @ Bearings/Min. Dia. of Eccentrics	100/145	125/170		165/235		180/235		
	Crankshaft Extension (Standard): Length/Diameter	165/85	255/100		255/125		225/125		
	Crankshaft Extension (Standard): Keyway Size	20 x 10	20 x 10		30 x 15		30 x 15		
	Adjustment of Slide: Standard Locking Arrangement	75	100		100		150		
<b>A</b>	Shutheight on Bolster, S.D.A.U. (Standard Stroke 25 mm)	320	370		470		495		
<b>A</b>	Shutheight on Bolster, S.D.A.U. (Standard Stroke 50 mm)	305	405		455		480		
<b>A</b>	Shutheight on Bolster, S.D.A.U. (Standard Stroke 75 mm)	290	395		420		445		
<b>A</b>	Shutheight on Bolster, S.D.A.U. (Standard Stroke 100 mm)	280	380		405	475	510		
<b>A</b>	Shutheight on Bolster, S.D.A.U. (Standard Stroke 125 mm)		355		375	445	495		
<b>A</b>	Shutheight on Bolster, S.D.A.U. (Standard Stroke 150 mm)			380		430	480		
<b>A</b>	Shutheight on Bolster, S.D.A.U. (Standard Stroke 175 mm)							420	
<b>A</b>	Shutheight on Bolster, S.D.A.U. (Standard Stroke 200 mm)							405	
<b>B</b>	Thickness of Bolster Plate	90	125		150		175		
<b>C</b>	Distance Floor to Top of Bed	865	915		1065		1065		
<b>d/D</b>	Opening in Upright (Absolute Maximum) F-B	265/305	355/405		380/455		380/510		
<b>M &amp; N</b>	Opening in Leg (Exit Side) T-B x F-B	355 x 315	355 x 355		380 x 455		380 x 510		
	Overall Height (Approximate)	2870	3405		3990		4115		
	kW and Speed of Variable Speed Motor Drives	11,25/1800	15/1800		18/1200 or 18/1800		22/1200 or 22/1800		
	Sliding Die Cushion -- Capacity	23 kN	87 kN		139 kN		139 kN		
	<b>WIDTH OF PRESS</b>				<b>1220</b>		<b>1525</b>		
<b>I &amp; K</b>	Area of Slide: R-L x F-B				1220 x 585		1525 x 760		
<b>J</b>	Distance Between Gibs				1270		1575		
<b>E &amp; F</b>	Area of Bolster and Bed: R-L x F-B				1220 x 1015		1525 x 1115		
<b>G &amp; H</b>	Opening in Bed: R-L x F-B				965 x 480		1370 x 445		
<b>L</b>	Floor to Bottom of Bed to Clear (Without Mounts)				355		305		
	Floor Space Overall: R-L x F-B				2820x2335	2715x2310	3175x2390	3075x2465	
	Weight (kg)				21.150	22.950	30.150	32.400	
	<b>WIDTH OF PRESS</b>	<b>1220</b>	<b>1220</b>		<b>1525</b>		<b>1830</b>		
<b>I &amp; K</b>	Area of Slide: R-L x F-B	1220 x 380	1220 x 470		1525 x 585		1830 x 760		
<b>J</b>	Distance Between Gibs	1270	1270		1575		1880		
<b>E &amp; F</b>	Area of Bolster and Bed: R-L x F-B	1220 x 635	1220 x 785		1525 x 1015		1830 x 1115		
<b>G &amp; H</b>	Opening in Bed: R-L x F-B	1065 x 230	1040 x 380		1270 x 455		1525 x 455		
<b>L</b>	Floor to Bottom of Bed to Clear (Without Mounts)	340	305		355		305		
	Floor Space Overall: R-L x F-B	2185x1370	2665x1525	2490x1830	3125x2335	3020x2310	3480x2385	3380x2465	
	Weight (kg)	8.910	12.690	13.770	23.400	25.650	30.600	32.400	
	<b>WIDTH OF PRESS</b>		<b>1525</b>						
<b>I &amp; K</b>	Area of Slide: R-L x F-B		1525 x 470						
<b>J</b>	Distance Between Gibs		1575						
<b>E &amp; F</b>	Area of Bolster and Bed: R-L x F-B		1525 x 785						
<b>G &amp; H</b>	Opening in Bed: R-L x F-B		1345 x 380						
<b>L</b>	Floor to Bottom of Bed to Clear (Without Mounts)		305						
	Floor Space Overall: R-L x F-B		2970x1525	2795x1830					
	Weight (kg)		13.950	14.940					

**See Page 9 For Stroke/Speed Combinations.**

For a complete list of optional sizes and features such as die cushions and double lock-up for lamination machines, please talk with your Minster representative or contact Minster direct.

# Minster Series P2 Specifications & Dimensions

(All Dimensions in Inches)

Dimen.	PRESS SIZE	P2-60		P2-100		P2-150		P2-200	
		Flywheel Type	Flywheel Type	Single Geared	Flywheel Type	Single Geared	Flywheel Type	Single Geared	
	<b>DIMENSIONS COMMON TO ALL WIDTHS</b>								
	Tons Capacity at Bottom of Stroke (U.S. Tons)	60	100		150		200		
	Crankshaft Dia. @ Bearings/Min. Dia. of Eccentrics	4/5.75	5/6.75		6.5/9.25		7/9.25		
	Crankshaft Extension (Standard): Length/Diameter	6/3.375	10/3.875		10/5.0		10/5.0		
	Crankshaft Extension (Standard): Keyway Size	.75 x .375	.75 x .375		1.25 x .62		1.25 x .62		
	Adjustment of Slide: Standard Locking Arrangement	3.0	4.0		4.0		6.0		
<b>A</b>	Shutheight on Bolster, S.D.A.U. (Standard Stroke 1.0")	12.5	14.5		18.5		19.5		
<b>A</b>	Shutheight on Bolster, S.D.A.U. (Standard Stroke 2.0")	12.0	16.0		18.0		19.0		
<b>A</b>	Shutheight on Bolster, S.D.A.U. (Standard Stroke 3.0")	11.5	15.5		16.5		17.5		
<b>A</b>	Shutheight on Bolster, S.D.A.U. (Standard Stroke 4.0")	11.0	15.0		16.0	18.75	20.0		
<b>A</b>	Shutheight on Bolster, S.D.A.U. (Standard Stroke 5.0")		14.0		14.75	17.5	19.5		
<b>A</b>	Shutheight on Bolster, S.D.A.U. (Standard Stroke 6.0")			15.0		17.0	19.0		
<b>A</b>	Shutheight on Bolster, S.D.A.U. (Standard Stroke 7.0")							16.5	
<b>A</b>	Shutheight on Bolster, S.D.A.U. (Standard Stroke 8.0")							16.0	
<b>B</b>	Thickness of Bolster Plate	3.5	5.0		6.0		7.0		
<b>C</b>	Distance Floor to Top of Bed	34	36		42		42		
<b>d/D</b>	Opening in Upright (Absolute Maximum) F-B	10.5/12.0	14.5/16.0		19.0/20.0		21.0/22.0		
<b>M &amp; N</b>	Opening in Leg (Exit Side) T-B x F-B	14 x 12.5	14 x 14		15 x 18		15 x 20		
	Overall Height (Approximate)	129	147		163		173		
	HP and Speed of Variable Speed Motor Drives	15/1800	20/1800		25/1200 or 25/1800		30/1200 or 30/1800		
	Sliding Die Cushion -- Capacity	2.5 Tons	9.6 Tons		15.3 Tons		15.3 Tons		
	<b>WIDTH OF PRESS</b>				<b>48</b>		<b>60</b>		
<b>I &amp; K</b>	Area of Slide: R-L x F-B				48 x 23		60 x 30		
<b>J</b>	Distance Between Gibs				50		62		
<b>E &amp; F</b>	Area of Bolster and Bed: R-L x F-B				48 x 40		60 x 44		
<b>G &amp; H</b>	Opening in Bed: R-L x F-B				38 x 19		54 x 18		
<b>L</b>	Floor to Bottom of Bed to Clear (Without Mounts)				14		12		
	Floor Space Overall: R-L x F-B				111 x 92	107 x 91	125 x 94	121 x 97	
	Weight (Lbs.)				47,000	51,000	67,000	72,000	
	<b>WIDTH OF PRESS</b>	<b>48</b>	<b>48</b>		<b>60</b>		<b>72</b>		
<b>I &amp; K</b>	Area of Slide: R-L x F-B	48 x 15	48 x 18.5		60 x 23		72 x 30		
<b>J</b>	Distance Between Gibs	50	50		62		74		
<b>E &amp; F</b>	Area of Bolster and Bed: R-L x F-B	48 x 25	48 x 31		60 x 40		72 x 44		
<b>G &amp; H</b>	Opening in Bed: R-L x F-B	42 x 9	41 x 15		50 x 19		60 x 18		
<b>L</b>	Floor to Bottom of Bed to Clear (Without Mounts)	13.5	12		14		12		
	Floor Space Overall: R-L x F-B	86 x 54	105 x 60	98 x 72	123 x 92	119 x 91	137 x 94	133 x 97	
	Weight (Lbs.)	19,800	28,200	30,600	52,000	57,000	68,000	72,000	
	<b>WIDTH OF PRESS</b>		<b>60</b>						
<b>I &amp; K</b>	Area of Slide: R-L x F-B		60 x 18.5						
<b>J</b>	Distance Between Gibs		62						
<b>E &amp; F</b>	Area of Bolster and Bed: R-L x F-B		60 x 31						
<b>G &amp; H</b>	Opening in Bed: R-L x F-B		53 x 15						
<b>L</b>	Floor to Bottom of Bed to Clear (Without Mounts)		12						
	Floor Space Overall: R-L x F-B		117 x 60	110 x 72					
	Weight (Lbs.)		31,000	33,200					

**See Page 9 For Stroke/Speed Combinations.**

For a complete list of optional sizes and features such as die cushions and double lock-up for lamination machines, please talk with your Minster representative or contact Minster direct.



# Speed/Stroke Combinations

Standard

PRESS	P2-60 Flywheel		P2-100 Flywheel		P2-150 Flywheel		P2-200 Flywheel		P2-100 Geared		P2-150 Geared		P2-200 Geared	
	Std. Speed	Max. Speed	Std. Speed	Max. Speed	Std. Speed	Max. Speed	Std. Speed	Max. Speed	Std. Speed	Max. Speed	Std. Speed	Max. Speed	Std. Speed	Max. Speed
1.0" (25 mm)	450	600	350	500	300	450	300	400						
1.5" (38 mm)	400	500	300	450	300	400	300	350						
2.0" (50 mm)	375	400	300	400	250	350	250	300						
2.5" (64 mm)	350	375	250	350	220	300	220	275						
3.0" (75 mm)	300	350	250	300	200*	250	200*	250						
4.0" (100 mm)	200	300	160	250	150*	225	150*	225	120	150	120	150	120	150
5.0" (125 mm)			160	200	150*	200*	150*	200*	100	150	100	150	100	150
6.0" (150 mm)							150*	180*	90	120	90	120	90	120
7.0" (175 mm)													90	120
8.0" (205 mm)													90	120

\* Requires 1200 RPM Drive Motor.

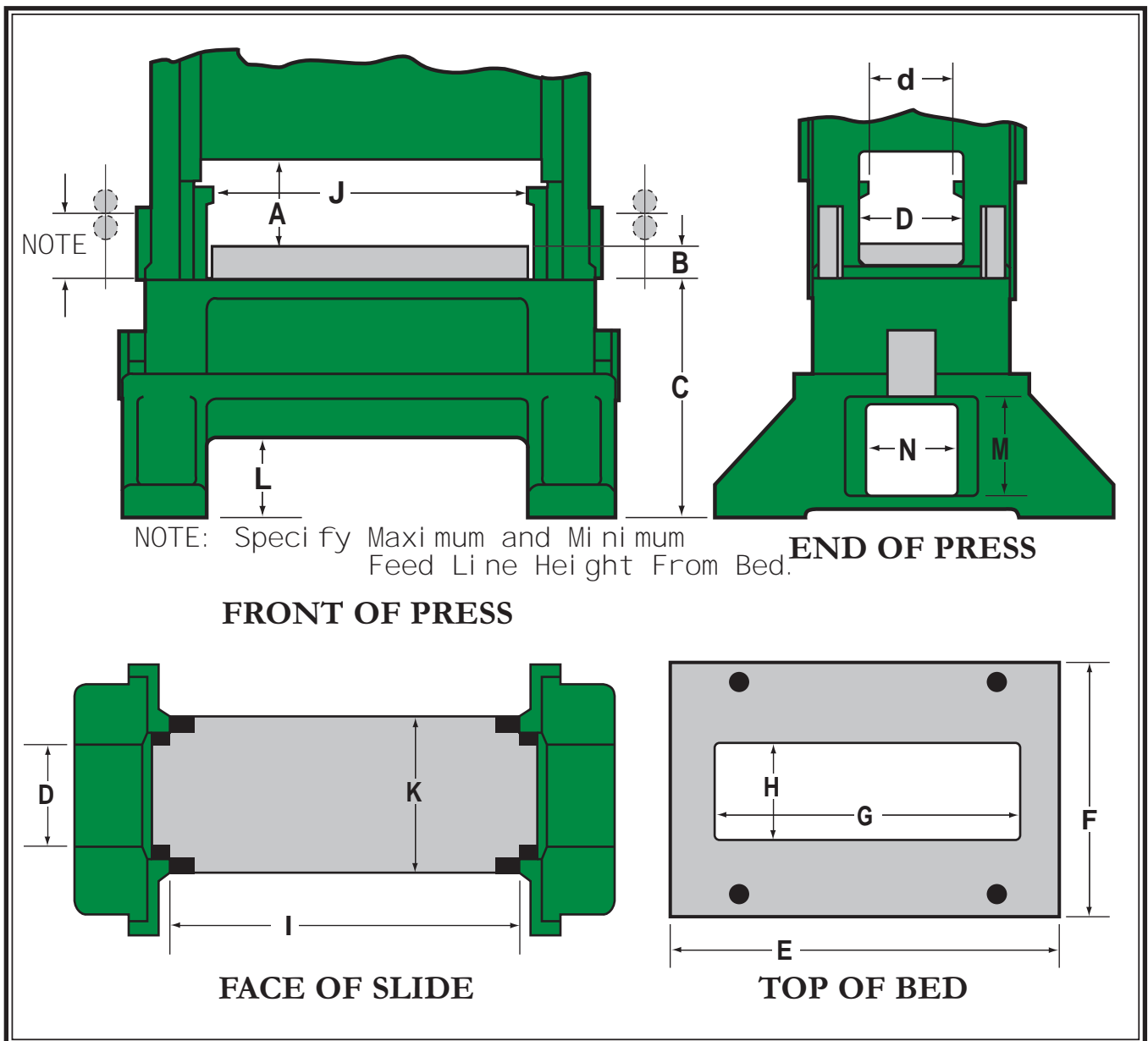



Minster GmbH,  
Halblech, Germany,  
Telephone: (49) 8368 9134 0



Nidec Shimpo, Kyoto, Japan  
Telephone: +81-75-958-3606



Nidec Minster S. de R. L.  
Querétaro, Mexico  
Telephone: (52) 442-253-1671

Minster China, Ningbo, China  
Telephone: +86 574 8630-8020



*Before You Invest in New Material Forming Technology, You're Invited to Visit Our Manufacturing, Training, Research, Parts and Service Facilities to See How "Minster Quality" is Built Into All of Our Products and Services.*



*A Century of Heritage Pressed Into a Lifetime of Quality*

240 WEST FIFTH STREET • MINSTER, OHIO 45865-0120 U.S.A. • PHONE: (419) 628-2331 • FAX: 419-628-3517

[www.minster.com](http://www.minster.com)

**Minster Has Sales and Service Offices Located Throughout the World  
Contact Minster Direct For The Name of Your Global Representative**