

KRONES ModulCheck
Autonomous inspection units



Compact lone fighters

KRONES ModulCheck

Quality checks are indispensable during bottling of beverages. However, one inspection system alone is not always the best choice.

ModulCheck is the optimal solution if you have only little space available or if you need only single inspection units. It is made up of cost-efficient single modules which altogether cover the entire range of empty and full bottle inspections. The compact modules are mounted directly to the conveyor and can be integrated or retrofitted at any spot of the bottling line. Just decide for yourself which module to use and where!



Method of operation

The containers pass through the inspection unit being close to each other. This is where they are inspected by a camera. In the case of a fault, they are immediately rejected and collected on a conveyor or a collecting bin.

Application

Inspection of empty or full glass or PET containers

Design features

- Installation directly on the existing conveyor
- Inspection via camera technology or sensor system
- Output: 72,000 containers per hour

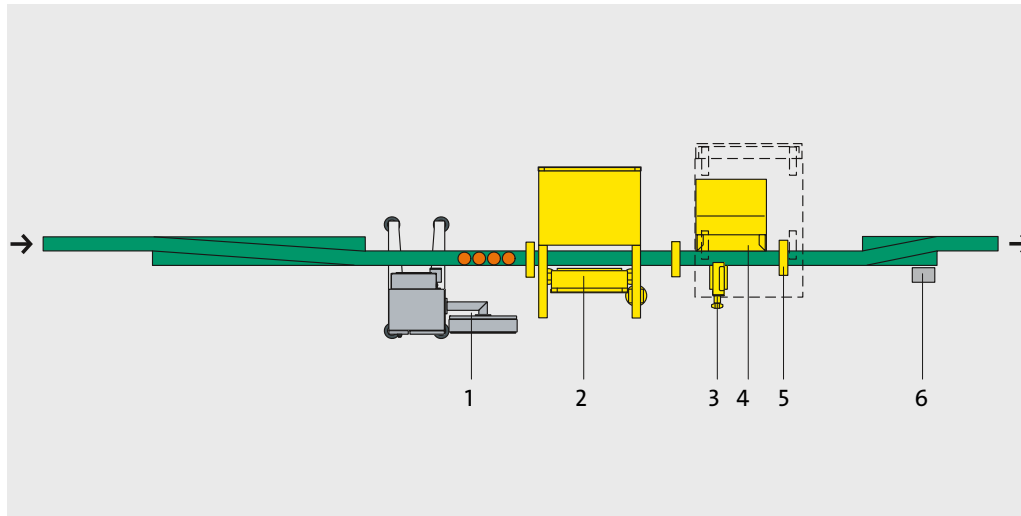

Example:

Suspended matter detection

- 1 Touch-screen with housing for electronic analysis unit
- 2 Suspended matter detection unit
- 3 Ecopush
- 4 Collector and container
- 5 Rejection monitoring
- 6 Encoder

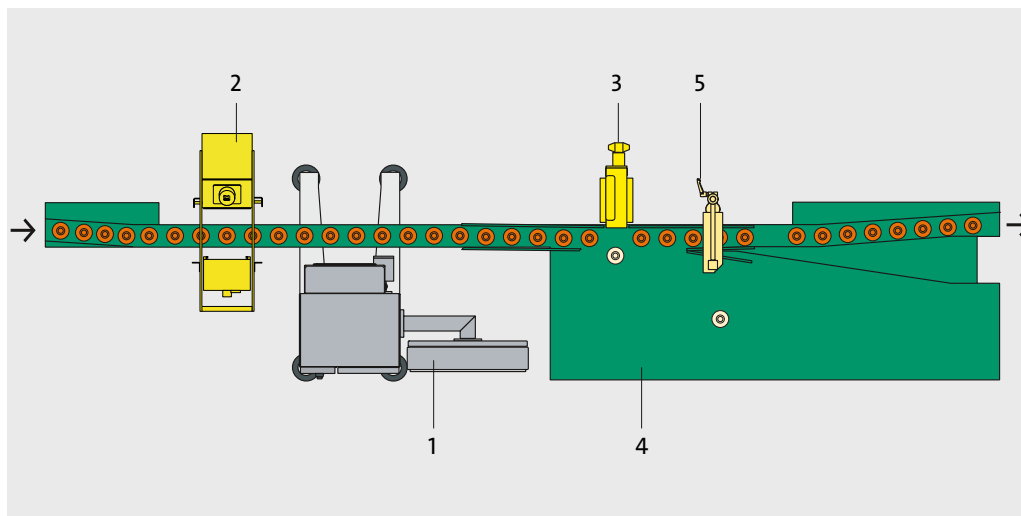

Example: *Contour detection*

- 1 Touch-screen with housing for electronic analysis unit
- 2 Contour detection unit
- 3 Pusher
- 4 Rejection table
- 5 Rejection monitoring

Custom-fit blocks

You can select freely which modules you wish to use. Select the units which are the right ones for your line layout and inspection need. Our product specialists will gladly consult you about the numerous possibilities the modular component system has to offer. Here are just a few examples of which inspection units can be realised with the ModulCheck:

- Foreign bottle inspection unit
- Sealing surface inspection unit
- Rubber seal inspection
- Sidewall inspection incl. scuffing
- ACL sorting
- Optimised scuffing inspection with PET containers
- Detection of suspended matters



*Sealing surface
inspection unit*

■ Small size

The compact modules require only little space and are mounted directly to the conveyor. They can easily be retrofitted in existing lines.

■ Maximum flexibility

The variable components can be integrated at any spot in the line. You can select freely which modules you wish to use where.

■ Quick start-up

Is there a short-term additional need for inspection? No problem: The ModulCheck systems are quickly available and ready for operation within shortest times.

■ State-of-the-art technology for an efficient price

ModulCheck grades up existing inspectors quickly and cost-efficiently. In stead of changing the entire machine, single components are simply replaced or added. Then, your inspector is still the same; it will merely have been brought to state-of-the-art technology.

*Contour
detection*



We do more.

 **KONPLAN**

 **SYSKRON**

 **KIC KRONES**

 **KOSME**

 **HST**
KRONES GROUP

 **EVOGUARD**

KRONES AG
Böhmerwaldstraße 5
93073 Neutraubling
Germany
Phone +49 9401 70-0
Fax +49 9401 70-2488
E-mail info@krones.com
Internet www.krones.com

KOSME s.r.l. unipersonale
Via dell' Artigianato, 5
46048 Roverbella (Mantova)
Italy
Phone +39 0376 751011
Fax +39 0376 751012
E-mail kosme@kosme.it
Internet www.kosme.com

EVOGUARD GMBH
Dr.-Hermann-Kronseder-Straße 1
93149 Nittenau
Germany
Phone +49 9436 307 700
Fax +49 9401 70 94 3700
E-mail info@evoguard.com
Internet www.evoguard.com

KIC KRONES
Internationale Cooperationsgesellschaft mbH
Böhmerwaldstraße 5
93073 Neutraubling
Germany
Phone +49 9401 70-3020
Fax +49 9401 70-3696
E-mail kic@kic-krones.com
Internet www.kic-krones.com

KONPLAN s.r.o.
Poděbradova 2842/1
301 00 Plzeň
Czech Republic
Phone +420 377 918 109
Fax +420 377 918 139
E-mail pilsen@konplan.cz
Internet www.konplan.cz

HST MASCHINENBAU GMBH
Gewerbstraße 19
23942 Dassow
Germany
Phone +49 38826 8878-0
Fax +49 38826 8878-1
E-mail info@hst-gmbh.com
Internet www.hst-maschinenbau-gmbh.de

SYSKRON GMBH
Oskar-von-Miller-Straße 6b
92442 Wackersdorf
Germany
Phone +49 9431 79857-0
Fax +49 9431 79857-11
E-mail info@syskron.com
Internet www.syskron.com

 **KRONES**