

lifgo® & lean SL® 5.0 – 5.3

Mechanical arrest system

Assembly instructions

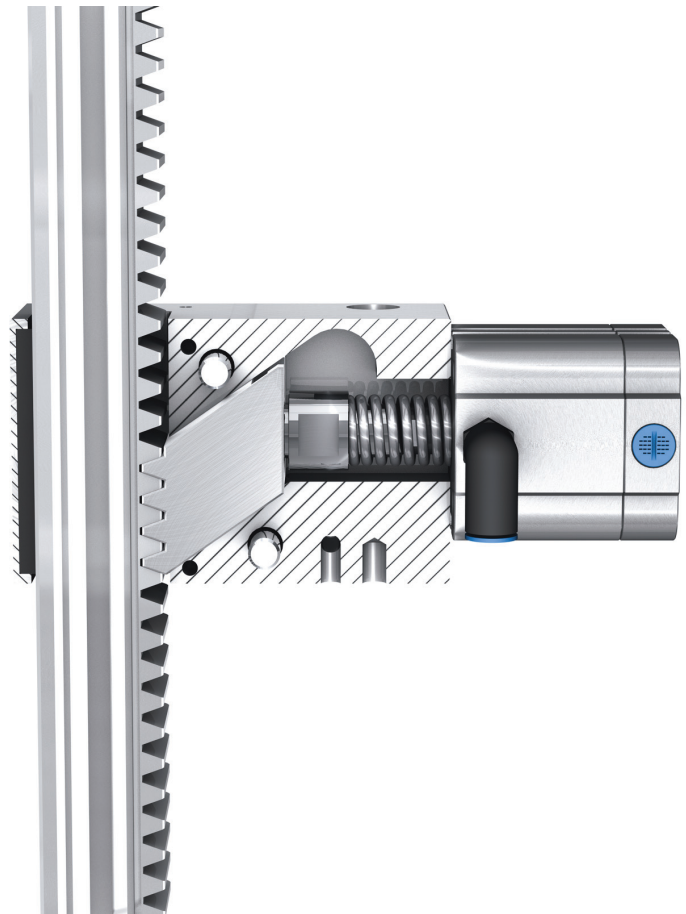

LEANTECHNIK AG

Year of manufacture: 2012 / Datum: 17.12.2012 / Version: 00
CE coordinator: Lukas Piofczyk / Editor: Martin Siemann

www.leantechnik.com

Index

1 Rules

1.1	Introduction	4
1.2	Machine designation	4
1.3	Contact address	5
1.4	Warranty	5
1.5	Product responsibility	5
1.6	Risk assessment	5
1.7	Declaration of incorporation	5
1.8	Scope of delivery	7
1.9	Symbols used	7

2 Product information

2.1	Intended use	8
2.2	Inappropriate use	8

3 Technical data (data sheet)

3.1	Dimension sheet	9
3.2	Weights and dimensions	10
3.3	Load capability	10
3.4	Adjusting drive	10

4 Safety instructions

4.1	General information on component operation	11
4.2	Choice of personnel and qualifications	13
4.3	Transporting the mechanical arrest system	13
4.4	Storing the mechanical arrest system	14
4.5	Installing the mechanical arrest system	14
4.6	Starting the component	14
4.7	Maintenance and repair	15
4.8	End-of-life, decommissioning, disposal	15
4.9	Resale of the component	16
4.10	Other provisions	16

5 Transport and lifting instructions

5.1	General	17
5.2	Adjacent machine parts	17

6	Function description	
6.1	Operating process	18
6.2	Installation positions	19
6.2.1	Gear rack moves the lift load	19
6.2.2	Gearbox moves the lift load	19
6.3	Gearbox	20
6.4	Unlocking	20
6.5	Locking	20
6.6	Required procedure	20
6.7	Proximity switches	20
7	Maintenance	
7.1	Screw connections	21
7.2	Rust protection	21
7.3	Lubrication	21
7.4	Lubrication and maintenance points	21
8	Spare parts	22
9	Standard parts	22
10	List of documents and drawings	22
11	Troubleshooting and fault correction	
11.1	General	23
11.2	Table	23

1 Rules

1.1 Introduction

These instructions describe the installation, operation and maintenance of the mechanical arrest system for lifgo®, lifgo® linear and lean SL® units of sizes 5.0, 5.1 and 5.3.

The mechanical arrest system is a mechanism designed to prevent the uncontrolled descent of components, elements in components or heavy weights and also to prevent the unwanted application of forces.

These instructions contain important details relating to the mechanical arrest system. To ensure the long-term, trouble-free operation of the system, it is essential that the instructions set out here are adhered to during all phases of the component lifecycle.

Read the current instructions carefully!

In the event of any doubt, contact LEANTECHNIK AG.

The manufacturer of the component is not liable for any environmental harm, damage to property or personal injury arising out of modifications or operations that do not conform to the present manual.

© Copyright

The reproduction of texts, images or drawings, either in whole or in part, is prohibited without LEANTECHNIK AG's written approval!

This also applies to the production of copies, translations, microfilming and storage in electronic systems.

1.2 Machine designation

The component is manufactured and marketed under the name 'Mechanical arrest system for lifgo®, lifgo® linear and lean SL®, sizes 5.0, 5.1 and 5.3' (see type plate).

This designation should be used in communications and any requests for information. In the remainder of this manual, the mechanical arrest system will be referred to as 'ASS', 'component' or 'system'.

LEANTECHNIK AG is the manufacturer of the mechanical arrest system.

1.3 Contact address

LEANTECHNIK AG

Im Lipperfeld 7c
46047 Oberhausen
Germany

Telefon ..49 (0) 208 · 495 25 - 0
Telefax ..49 (0) 208 · 495 25 -18

E-Mail info@leantechnik.com

www.leantechnik.com

CE coordinator: Lukas Piofczyk

1.4 Warranty

As an exception to the General Terms and Conditions (GTC), the manufacturer's warranty issued by the company LEANTECHNIK AG runs for 2 years.

⇒ see separate documentation: 'GTC'

The warranty for spare parts runs for 12 months following first usage of the parts and for a maximum of 24 months following delivery.

When replacing parts or performing repairs, only use original LEANTECHNIK AG spare parts since no guarantee can be given of the perfect material quality, correct dimensioning and correct machining of parts from other sources.

Any modifications or conversions made without the manufacturer's express written approval will result in the loss of any entitlement to warranty claims!

1.5 Product responsibility

LEANTECHNIK AG, as manufacturer of the component, and the operator are responsible for the component and the individual components it comprises.

The responsibility of the operator relates primarily to operating safety and maintenance of the component.

The manufacturer will accept no liability for damage or injury arising from the incorrect use of the product.

1.6 Risk assessment

LEANTECHNIK AG, as the manufacturer of the component, possesses a detailed risk assessment.



Danger!

When activating the mechanical arrest system, there is a danger of hair, clothing or body parts being pulled in!

If the mechanical arrest system is installed incorrectly, correct operation is not guaranteed!

On disassembly, the mechanical arrest system must not be active and no load may be applied!

1.7 Declaration of incorporation

The following declaration applies to machines that are not ready for use, i.e. which cannot function on their own and which are incomplete in terms of safety provisions (submachines).

The mechanical arrest system for lifgo®, lifgo® linear and lean SL®, sizes 5.0, 5.1 and 5.3 belongs to this category.

LEANTECHNIK AG

Im Lipperfeld 7c · D - 46047 Oberhausen
Telefon ..49 (0) 208 · 495 25 - 0
Telefax ..49 (0) 208 · 495 25 -18
E-Mail info@leantechnik.com

www.leantechnik.com

Declaration of incorporation

In accordance with the EU Machinery Directive 2006/42/EC, Annex II B:

Name of manufacturer **LEANTECHNIK AG**
Adress **Im Lipperfeld 7c**
46047 Oberhausen
Germany

We declare herewith that the partly completed machine designated below complies with the EU Machinery Directive 2004/42/EC and subsequent amendments through to its interfaces:

Designation / type: **Mechanical arrest system (ASS) for**
lifgo[®], lifgo[®] linear, lean SL[®]
sizes 5.0, 5.1 and 5.3

Order number: _____ Article: _____ Date of manufacture: _____

The following harmonized standards apply:

EN 12100 Safety of Machinery, Basic Concepts Parts 1 and 2
EN ISO 14121-1 Safety of Machinery, Risk Assessment

The designated partly complete machine is intended for installation in a machine or for assembly with other machines.

We declare that commissioning is prohibited until the machine or component in which this partly complete machine is installed or of which this partly complete machine forms a component complies in its entirety with the provisions of the Machinery Directive 2006/42/EC and the Declaration of Conformity as set out in Annex II A is available.

The present declaration shall cease to be valid in the event of any modification not agreed upon with us.

Authorised representative for the compilation of technical documentation:
Lukas Piofczyk (CE coordinator)

Oberhausen,

Date: _____ **Signature (Managing Director):** _____

1.8 Scope of delivery



The LEANTECHNIK AG scope of delivery comprises the following items:

- Mechanical arrest system
- Pneumatic system
- Proximity cylinder
- Assembly drawing
- Operating instructions in English
- Assembly and acceptance at LEANTECHNIK AG

The scope of delivery does not include:

- Electrical controller
- Operator controls
- Safety-relevant connections / overall concept
- Final installation
- Test run
- Commissioning
- Lubricating oils and greases
- Preparation and provision of pneumatic and electrical supplies

1.9 Symbols used

1. Caution sign		Caution! or Danger!
2. Information sign		Important installation, safety, and functional notes

2 Product information

2.1 Intended use

The mechanical arrest system is a mechanism design to prevent the uncontrolled descent of systems, system components or heavy weights and also to prevent the unwanted application of forces and is attached to / installed in gear racks.

It may only be used to protect systems / machines / equipment against falling or sudden collapse during inspections or in the event of repair work.

The mechanical arrest system may only be used together with lifgo®, lifgo® linear or lean SL®.

All other uses and functions are prohibited!



Caution! Divergent uses, even if only in part, of individual components of the mechanical arrest system are also prohibited!!

2.2 Inappropriate use

All functions and procedures that have not been explicitly approved for the mechanical arrest system are prohibited.

The mechanical arrest system must not be used as a brake / emergency brake!

This also applies to any departures from the provisions of sections 2.1 and 3!

3 Technical data (data sheet)

3.1 Dimension sheet

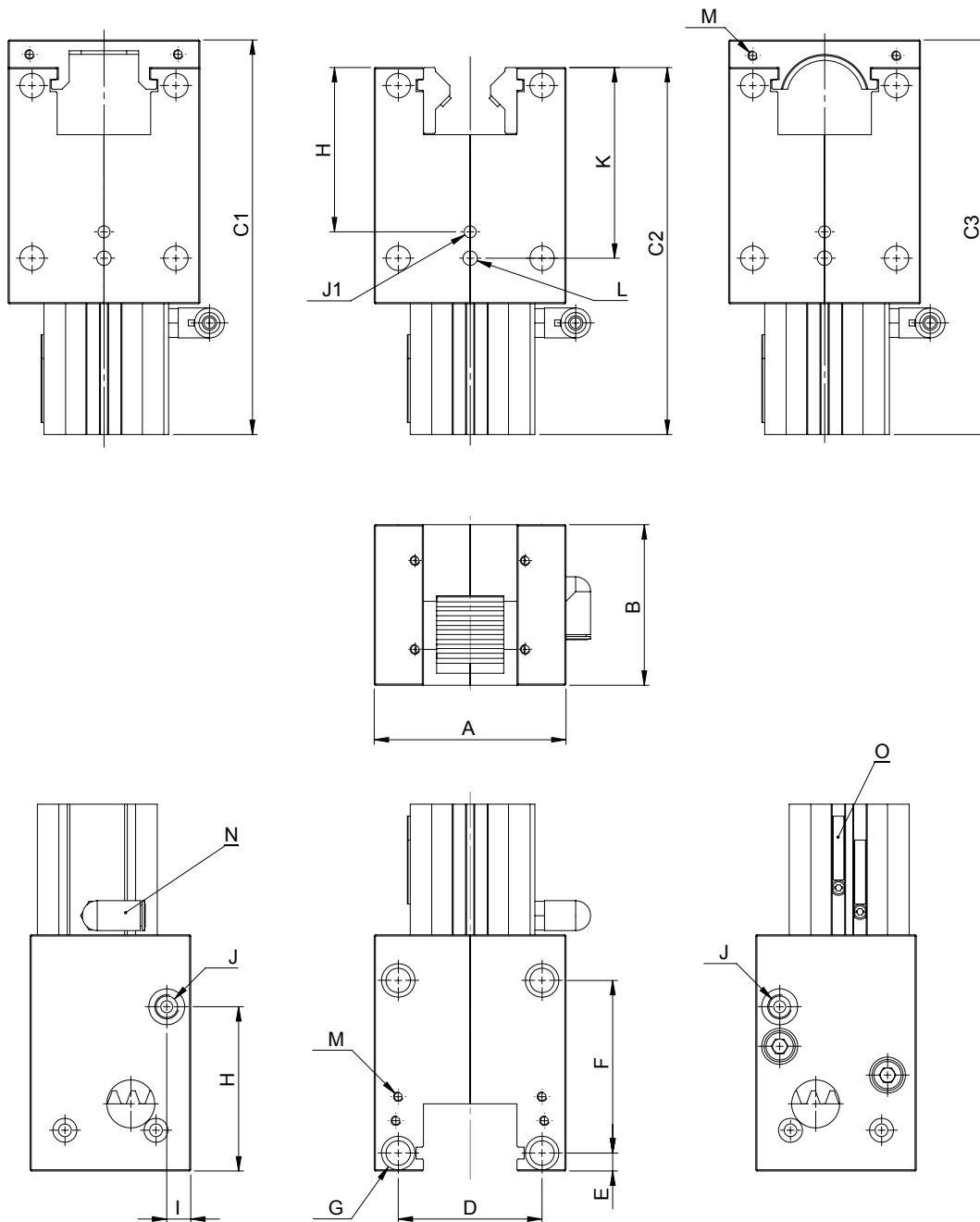

3.2 Weights and dimensions

Mechanical arrest system (ASS) for lifgo®	Unit	5.0	5.1	5.3
A	mm	70	80	130
B	mm	55	67	90
C1	mm	124,5	164,5	216,5
C2	mm	116	153	197,5
C3	mm	124,5	164,5	216,5
D	mm	55	60	105
E	mm	6,5	7,5	11
F	mm	50	72	120
G	mm	∅ 8,2 through └┬∅12 ↓ 8,6	∅ 10,2 through └┬∅14 ↓ 10,6	∅ 13 through └┬∅20 ↓ 12,6
H	mm	45,5	68,5	106
I	mm	10	10	10
Lube hole for pinion/gear rack	J	mm	M6 ↓ 6	M10x1 ↓ 10
	J1	mm	∅ 5	∅ 5
	K	mm	56,5	79,5
Dowel hole	L	mm	∅ 6F7 ↓ 10	∅ 6F7 ↓ 10
For gear rack protection	M	mm	M4	M4
Plug-in connector for air hose	N	mm	∅ 6	∅ 6
Proximity switch	O		SME-8F-DS-24V-KO,3-M8 LZ Festo	
Weight lifgo®	kg	1,9	3,3	10,5
Weight lifgo® linear	kg	1,8	3,5	11,4

3.3 Load capability

Load-bearing capacity: at least 5 times the safety provided by gears

3.4 Adjusting drive

	Locking	Note
Number of motors	1x pneumatic cylinder	
Pressure	Min. 5 bar	
Auxiliary voltage	24 V DC	

4 Safety instructions

4.1 General information on component operation

The safety instructions apply to all component lifecycle phases. These include transportation, installation, commissioning, service life, maintenance, troubleshooting and decommissioning.

All specialist personnel responsible for the component must read the operating and maintenance manual. The manual must be available at all times. The personnel must read and understand the manual.

The operating and maintenance manual must be kept in good condition. Damaged, lost or illegible pages must be replaced immediately.

All sequences and specifications relating to the correct operation of the component must be observed.

Some details:

- Only use the component in accordance with specifications set out in sections 2.1 and 3!
- Do not adjust or turn any proximity switches!



Caution! The safety mechanisms and rules must be harmonized with the safety concept of the overall system (feed-in and removal mechanisms, drives, controller)!

The component may only be operated by authorized personnel during all lifecycle phases, including the elimination of problems (troubleshooting).

In addition to the points mentioned throughout the manual, the following points must be observed when operating the component:

- These safety instructions should be considered as a guideline and extension to applicable national legislation.
- All persons who work with the component must be familiar with the relevant component technology.
- Repairs must be performed by qualified specialists who are familiar with the product and the associated technology.
- Transportation and repair work, as well as installation, must be performed with extreme care and attention to avoid any damage to the component.
- All persons who work with the component must observe the instructions and regulations set out in the present manual.
- A completely up-to-date version of these instructions must always be present in the vicinity of the component and be accessible to operators.
- All changes at the component that deviate from the original layout must be recorded in these instructions.
- If any malfunction occurs then the cause must be eliminated immediately. If the cause of the malfunction cannot be identified and/or eliminated, then help must be obtained immediately from a specialist or from the company LEANTECHNIK AG.

- The use of spare parts not supplied by LEANTACHNIK AG is not permitted since we have not inspected these parts and they may therefore have a negative influence on the reliability of the product.
- The use of spare parts not supplied by LEANTECHNIK AG invalidates the component warranty since we do not accept any liability for such spare parts.
- Lubricant oils, detergents, preservatives and acids must be collected and disposed of in accordance with the applicable legislation.
- Keep clothing, hands and other parts of the body away from moving parts, e.g. rollers, drums, belts, levers etc.! You should preferably wear closely fitting clothes and tie long hair back.
- Before moving or transporting anything, make sure that there is no-one in the risk area.
- Before any maintenance work, the power supply must be disconnected and the mechanical locking devices provided for this purpose must be activated!
- Observe the safety notes and signs on the component.
- Take all possible preventive measures to avoid injury or damage of any type. Make sure that the component can be operated and repaired safely under all circumstances.

Potential sources of danger at the component are all identified in the hazard examination and risk analysis.

⇒ see section 1.6 Risk assessment



Danger!

Never bypass any safety mechanisms!

Never deactivate any safety mechanisms!

All specialist personnel who operate and maintain the drive must read the operating and maintenance manual.

- The manual must be available to operators at all times.
- The operators must read and understand the manual.



In the event of any doubt or uncertainty, it is essential to contact the manufacturer of the component!

The operating and maintenance manual must be kept in good condition. Damaged, lost or illegible pages must be replaced immediately.

The safety regulations set out in the following documents must be strictly adhered to:

- Operating and maintenance manual
- Legally applicable accident prevention regulations
- The company's internal safety, operating and working instructions

The machine and component manufacturer cannot be held liable for damage to property or personal injury in the following cases:

- If the component has been modified compared to its original design
- If the component has been used or maintained in ways contrary to those set out in these instructions.
- If the component has been operated or maintained by untrained or unauthorized personnel.

4.2 Choice of personnel and qualifications

Activity (lifecycle phase)	Persons	Specially trained personnel	Instructed operating personnel	Instructed personnel with specialist training (mechanics / electrical engineering)
Transport		X	–	–
Installation		X	–	–
Commissioning		X	–	–
Setup		X	–	X
Normal operation		X	X	–
Cleaning		X	X	–
Maintenance		X	–	X
Troubleshooting and correction of faults		X	–	X
Disassembly		X	–	–
Disposal / recycling		X	–	–

Key: X = Permitted / – = Not permitted

Internal instructions must define, on the basis of the employees' qualifications, who is responsible for what tasks and is then authorized to perform them.

The minimum legal age of personnel must be observed.

4.3 Transporting the mechanical arrest system

The mechanical arrest system is transported in its assembled state.

⇒ see the documentation for lifgo®, lifgo® linear and lean SL®

⇒ see section 5 Transport and lifting instructions

4.4 Storing the mechanical arrest system

The component is treated with a preserving agent ex-works. The parts are therefore protected against for a maximum of 6 months if stored in a dry environment.

The corrosion protection at all unpainted areas (sliding areas, gear racks) must be inspected before admission into storage and renewed if necessary. Prior to a trial run, the corrosion protection must be removed and replaced by the lubricant specified in the maintenance instructions.

The component must never be stored outdoors.



Caution! No other parts may be stored on the mechanical arrest system!

4.5 Installing the mechanical arrest system

The component must be installed in accordance with the supplied general drawing.

⇒ see drawing for article number

Before starting installation, make sure that all the parts have been supplied and are available. All the parts must be installed correctly.

The electrical and pneumatic connections must be established.

We cannot accept liability for errors or damage of any type.

4.6 Starting the component

Before start-up, the mechanical arrest system must be integrated in the overall safety concept.

The personnel must be trained and qualified.

All measurement and alarm displays (safety components) must be installed and checked for error-free functioning before the component is activated. If one of the displays indicates a malfunction, do not activate the mechanical arrest system. If the malfunction occurs after the component has been activated for the first time, check the functioning of the mechanical arrest system and the safety system again.

Make sure that the required lubricant has been applied at all lubrication points.

⇒ see lubrication and maintenance schedule in section 8.7.



Caution! Check whether the proximity switches are activated correctly.

4.7 Maintenance and repair



Caution!

The safety notes in section 4 apply!

The mechanical arrest system must not be repaired.

If damage occurs, the complete mechanical arrest system must be replaced!

The mechanical arrest system must be installed and removed by specialist personnel.

Maintenance must be performed under the best possible conditions.

In the event of an accident, a doctor must always be called.

The fixing bolts must be tightened correctly and with the correct torque (see section 8.4) and secured against unintentional release.

For further information on maintenance, see the maintenance schedule in section 8 of these instructions.



Danger! When cleaning parts with compressed air, protective goggles must always be worn.



4.8 End-of-life, decommissioning, disposal

When the component is decommissioning, ensure that the environmental protection regulations are observed. This means that different materials must be separated prior to disposal (different metals isolated, plastic, rubber, electronics, etc.).

Mechanical parts must be separated from electrical, pneumatic and hydraulic parts, i.e. remove cable harnesses, dismount motors, remove hoses, collect fluids etc.

All parts must be free of oil and grease. Oil and grease must be removed and disposed of in accordance with regulations.

All parts that were lubricated during the product's service life must be cleaned.



Regulations and legislation relating to the disposal of oil and grease must be complied with. Companies that dispose of these materials must present the necessary authorizations.

4.9 Resale of the component

If the component is resold, all the regulations regarding decommissioning described in section 4.8 must be observed.

The purchaser must also be supplied with the documentation in perfect condition.

4.10 Other provisions

In general, the following also applies:

- Do not depart from the technical specifications as set out in sections 2.1 and 3!
- Do not adjust or turn any proximity switches!
- All national (legislation, accident prevention regulations etc.) and, if applicable, international safety regulations must be observed during maintenance, cleaning, repair, installation and troubleshooting operations!
- The safety instructions and provisions set out in the maintenance manuals for the individual machines such as the lifgo[®], lifgo[®] linear and lean SL[®] must also be observed!
- Smoking is prohibited in the proximity of flammable materials.



Caution! In the event of any questions regarding functions which you are unable to answer or problems to which you are unable to identify a solution, it is essential to contact the component manufacturer!



If you are in any doubt, it is also essential to contact the component manufacturer!

5 Transport and lifting instructions

5.1 General

The mechanical arrest system must be lifted and moved by hand.

⇒ see the documentation for lifgo®, lifgo® linear and lean SL®

If lifting cables or slings are used then it is important to make sure that these do not touch the proximity switches and hoses on the cylinder since this could deform or destroy parts and the component may then be unable to perform its function.

When lifting and putting down the component, avoid any jolts or impacts.

 Any load-lifting equipment such as eye bolts, straps or cables must be designed to support the weight to be lifted. The weight of an individual mechanical arrest system is indicated in the data sheets.

5.2 Adjacent machine parts

Adjacent parts must first be dismantled.

Hose, tube and cable connections must be disconnected from the machine that is to be transported and stowed in a way that is suitable for transportation.

6 Function description



Caution! The mechanical arrest system is not an emergency brake!

6.1 Operating process

The LEANTECHNIK AG mechanical arrest system (short name: ASS) is a mechanism designed to prevent the uncontrolled descent of systems, system components or heavy weights and also to prevent the unwanted application of forces and is attached to / installed in gear racks in combination with a lifgo[®], lifgo[®] linear or lean SL[®].

It is used to protect systems / machines / equipment etc. against falling or sudden collapse during inspections or in the event of repair work.

When used in combination with a lifgo[®] or lean SL[®] gearbox, the ASS can also be used as a positioning unit for a given value. Please consult us for further information!

The secured force is 5 times greater than the nominal force of the associated lifgo[®] or lean SL[®] gearbox. It is not permitted to exceed these forces at any time.

The force is secured in only one direction of movement (see drawing on the next page) which is opposite to the load or lifting direction and only provided that an electronic drive containing a service brake is used.

This protective device has a simple, robust method of operation. In normal operation, an air cylinder keeps the ASS open against a mechanical spring pressure. This is the "free-moving position". When it is necessary to apply the protective device, the system / machine / equipment is first stopped.

The air is drained from the ASS air cylinder and the spring pressure forces the toothed bar towards the gear rack. The inductive switch at the air cylinder indicates that the mechanism has left its "free-moving" position. The system is now descended at low speed until the spring pressure fully engages the toothed bar in the gear rack. When this "locked position" has been reached, a second inductive switch indicates this to the control unit. The downward movement is stopped immediately. The system / machine / equipment is now mechanically held in place by the interlocking components.

If the system has to be unlocked again then the air cylinder must be pressurized again. The system / machine / equipment is then lifted at low speed. The toothed bar is released and pressed back by the pressure from the cylinder. The inductive switch first indicates that the locked position has been exited and then that the free-moving position has been reached. The system / machine / equipment can resume normal operation again.

In case there is a power supply failure, the system's service brake must first be engaged. Shortly afterwards, the air cylinder is depressurized. The toothed bar moves towards the gear rack to just in front of the closest tooth. If the system / machine / equipment does not descend any further, nothing else happens! If, for whatever reason, the system / machine / equipment continues to descend, the spring pressure forces the toothed bar into the next possible tooth space and the mechanical interlock halts the system / machine / equipment.

In accordance with VDE and EU guidelines, all the functions must be wired in a suitable control unit as per DIN 60204.

6.2 Installation positions

6.2.1 Gear rack moves the lift load

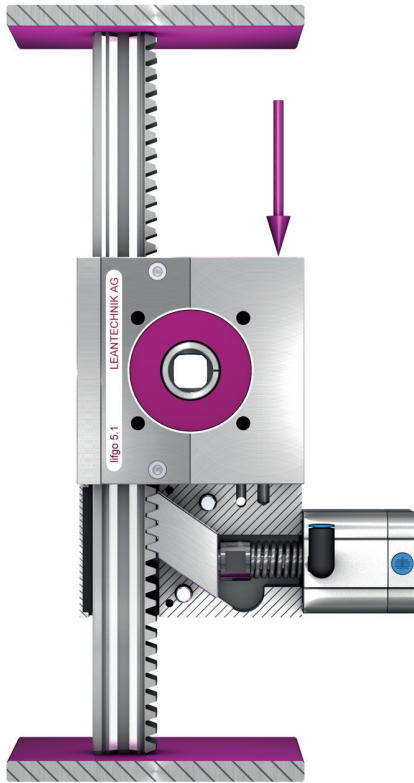

6.2.2 Gearbox moves the lift load

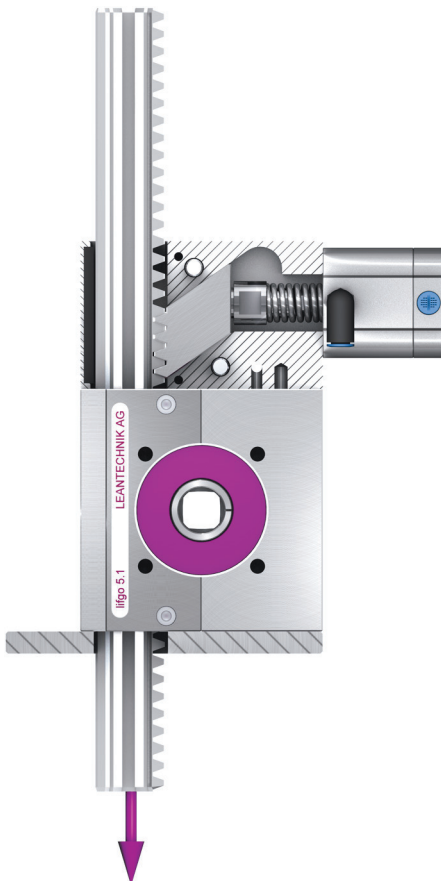

6.3 Gearbox

⇒ see the documentation for lifgo®, lifgo® linear and lean SL®

The dimensions at the contact points with the gearbox can be found in the assembly drawings.

6.4 Unlocking

The attached air cylinder disengages a release bar from the gear rack and is held in this position as long as pressure is still present in the cylinder. The mechanical arrest system is now unlocked.

6.5 Locking

When the air pressure is removed, a spring pushes the release bar forwards until it engages between the teeth of the gear rack. The mechanical arrest system is now locked. To increase locking reliability, the air cylinder can also be moved in the direction of the spring. However, this is not necessary for operation and is not provided for as standard.

6.6 Required procedure

Before a system is locked, it must be moved to the required height. The locking mechanism is then activated by depressurizing the mechanical arrest system's lifting cylinder. Complete locking is only ensured once the system has slowly descended by a maximum of 8 mm after activation so that the teeth in the gear rack and release bar engage with one another.

The angle of entry of the release bar into the gear rack guarantees that the mechanical arrest system cannot become unlocked by itself.

In order to unlock the mechanical arrest system, the system must be raised approximately 5 mm.

6.7 Proximity switches

Two Festo proximity switches (type SME-8F-DS-24V-KO, 3-M8 LZ) are affixed to each air cylinder in order to check the strokes. These query the position or state (locked or unlocked) of the mechanical arrest system. The locking or unlocking operation is not completed until all 4 cylinders are inserted or retracted and have emitted a signal.

Air is supplied via quick-fit connectors for 6 mm hoses.

7 Maintenance

7.1 Screw connections

⇒ see the documentation for lifgo®, lifgo® linear and lean SL®

7.2 Rust protection

To ensure their antifriction properties, the smooth metal surfaces of the ASS have film of oil or grease. However, this film also helps protect the parts against rust.

7.3 Lubrication

The bar on the mechanical arrest system is lubricated for life.

7.4 Lubrication and maintenance points

To ensure the long-term, maintenance-free operation of the component and reduce technical problems to a minimum it is necessary to observe the instructions set out in this section.

Maintenance work	Daily	Monthly	After 500 hours (or every 6 months)	After 1000 hours (or annually)
lifgo®, lifgo® linear, lean SL®	See separate documentation for lean SL®			
Check screw and pin connections				X
Check mechanical arrest system (stroke, sensors and release bar)		X		

8 Spare parts

There are no spare parts for the mechanical arrest system. Defective mechanical arrest systems must be replaced in their entirety.

The manufacturer's ordering address can be found in section 1.3.

9 Standard parts

LEANTECHNIK AG's suppliers are listed below:

Name	Supplier
Electrical components	Festo
Pneumatic components	Festo

10 List of documents and drawings

Further individual documents and drawings are as follows:

Drawing	Name
For article	Data sheet Documentation for lifgo®, lifgo® linear, lean SL® Supplier documentation in accordance with section 10.

11 Troubleshooting and fault correction

11.1 General

This section contains troubleshooting information. It is intended to simplify the task of identifying the sources of faults.

But, here again, the general rule applies: If the source of a fault cannot be unambiguously identified then, if in doubt, contact the manufacturer of the component.



If you are in any doubt, it is essential to contact the component manufacturer!

11.2 Table

Fault	Possible cause	Solution
Mechanical arrest system does not lock	Release bar not engaged in tooth space	Repeat procedure in accordance with section 6.7
	Release bar is broken	Replace the mechanical arrest system
	Sensors dirty or defective	Clean or replace the sensors
Mechanical arrest system does not unlock	Release bar is stuck	Repeat procedure in accordance with section 6.7
	Sensors dirty or defective	Clean or replace the sensors