

# KB48 Programmable Membrane Keyboards

## Every picture tells a story....

- Designed to replace standard PC keyboards in industrial environments.
- RS232 or PS/2 versions
- Panel-Mount or Desk-Top Models
- Up to 48 keys
- User definable key codes
- Small size – 204mm x 88mm
- IP66 when panel mounted



Desk-Top Model

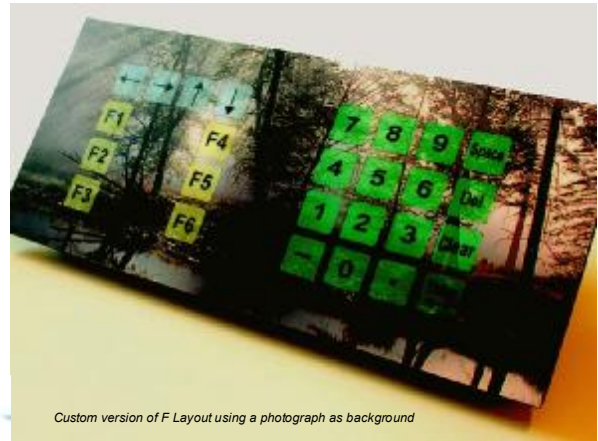

Custom version of F Layout using a photograph as background

Programmable keyboards integrate directly with the operator and the system, simplifying and clarifying the purpose and functionality of the human interface.

Underneath the keytop are true tactile push-switches in a layout of 4 rows x 12 keys, more than enough for a full alpha-numeric entry but which can be configured for any number of keys from 1 to 48.



Panel Mount Version

## Custom Graphics

The membrane graphics are completely at the control of the customer. On our website ([www.industrialdataproducs.co.uk](http://www.industrialdataproducs.co.uk)) we provide a 48 key template with sample key legends, which can be easily changed by the customer using a standard graphic package (such as CorelDraw). Logos, clipart, and photographic images can all be incorporated in full colour and high resolution. The design is emailed to us for printing directly onto the polyester membrane using our digital print technology. In this way there are no artwork or setting up costs.

Our keyboard configuration tools can assign ASCII codes (RS232 version) or PC codes (PS/2 version) to any key.

## Construction

Manufactured from tough, black-anodised aluminium, the keyboards are available in desk-top or panel-mount format.

## Standard Keyboards

For customers not wishing a fully custom layout there are 3 standard layouts also available

**A layout** – 48 keys in ABC format with separate numeric pad

**Q layout** – 48 keys in QWERTY format (there are separate versions for RS232 and PS2)

**F layout** – 26 keys function and arrow keys + numeric pad



A Standard Layout



Q WERTY (RS232 version)

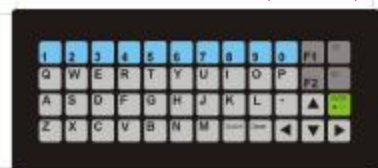

Q WERTY (PS2 Version)

## Programming Tools (To configure the key code assignments).

Each key can be assigned a keycode. There are separate tools for the RS232 and PS/2 models. The tools run in a PC/Windows environment and the KB48 keyboard is connected to the PC comport for programming. The tools can be downloaded free of charge from our website at [www.industrialdataproducs.co.uk](http://www.industrialdataproducs.co.uk).



### RS232 Programming Tool

Each key is assigned an ASCII code using a graphic depiction of the 48 key layout (see illustration on left) Normal, Shifted and Control values can be included if required but it is also possible to configure a simple keyboard without these attributes. Optional Key Repeat. Keyboard configurations can be saved and reloaded using the supplied cable.



### PS/2 Programming Tool

Allows each of the 48 keys on the KB48 keyboard to be assigned with any key on a standard PC keyboard. A "learning" feature combines with a graphical representation of the standard PC layout to let the programmer simply click on the PC key to assign it to the KB48. A series of programmable keys that can store multiple code sequences, ensures that all key codes can be used. Keyboard configurations can be saved and reloaded (Download cable required)

### Panel mount fixing details

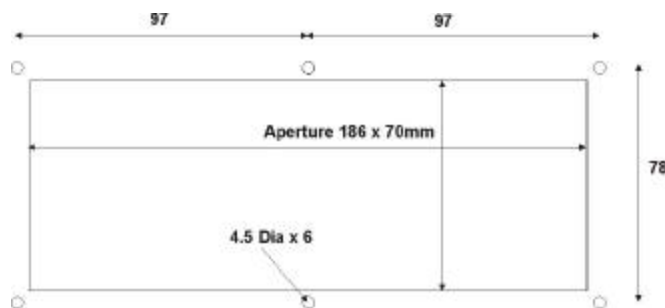

### Connections

The PS/2 versions include a PS/2 type mini-din connector on 2m of cable.

RS232 models have a 2m cable with the end free for termination by the customer. The connections are:

- |                  |                                       |
|------------------|---------------------------------------|
| Black and shield | 0v                                    |
| Red              | +5v                                   |
| Blue             | RS232 Txd from the KB48 to host       |
| Green            | RS232 Rxd (only used for programming) |

## Order Codes :

**KB48 - C - 232 - DT**

- DT = Desk-Top
- PM = Panel-Mount
- 232 = RS232 Version
- PS2 = PS/2 Version
- C = Custom model
- A = ABC layout
- Q = QWERTY layout
- F = Function key layout
- Product Name (Always KB48)



### Industrial Data Products Ltd.

The Studio, Oldbury Business Centre,  
Cwmbran, Gwent, UK NP44 3JU

Tel. +44 (0)1633 838411

Fax. +44 (0)1633 860689

Email : [sales@idp.uk.com](mailto:sales@idp.uk.com)

Website: [www.industrialdataproducs.co.uk](http://www.industrialdataproducs.co.uk)