

# LANCASTER PRODUCTS

World Leaders in Material Processing Equipment



## Lancaster® Rotary Table Feeder

**LANCASTER®  
PRODUCTS**

Manufactured by Kercher Industries, Inc.

1.800.447.7351

outside of U.S. phone: 717.273.2111 fax: 717.273.2967

email: [info@lancasterproducts.com](mailto:info@lancasterproducts.com) [www.lancasterproducts.com](http://www.lancasterproducts.com)

The Lancaster Products Line of Material Processing Equipment

High Shear K-Series Mixers

Low Shear L-Series Mixers

K-Lab Mixers

Pug Mills

Roll Crushers

Table Feeders

Automated Material Handling and Batching Systems

AutoBrik Molded Brick Making Machines

# Lancaster® Rotary Table Feeder

Lancaster Rotary Table Feeders are particularly helpful in moving sticky or hard to feed materials. They are also very useful in converting an intermittent batch process into a continuous material feeding process.

The Lancaster Rotary Table Feeder consists primarily of a transition cone, a rotating table, a discharge plow, a drive mechanism, and a support structure. The table feeder uses a large flat rotating table to continually bring material from the cone to the discharge plow. The table has vertical pins attached inside the cone area. There is also a cone scraper blade attached to the table. As the table turns, the blade and pins agitate the material and keep it evenly flowing to the discharge plow. An adjustable seal band rides on the outer surface of the table to prevent material from exiting the table feeder outside the discharge area. The discharge plow is used to bring the material to a fixed point as it leaves the table.

The rotating pins and the inner rotating plow provide a constant feed of even the most difficult materials. The amount of material leaving the table feeder can be controlled by changing the angle of the discharge plow via a hand wheel. The feed rate can also be changed by using a variable speed drive with the table drive motor.

For bin discharging applications, the Lancaster Table Feeder attaches directly to the bin walls forming the bottom of the bin. Some of the most difficult flowing materials can then be evenly fed from the bin.

The table feeder can also convert a batching process into a continuous process. The cone over the table is then used as a surge hopper to temporarily store the material batch while the table feeder continuously discharges the material.

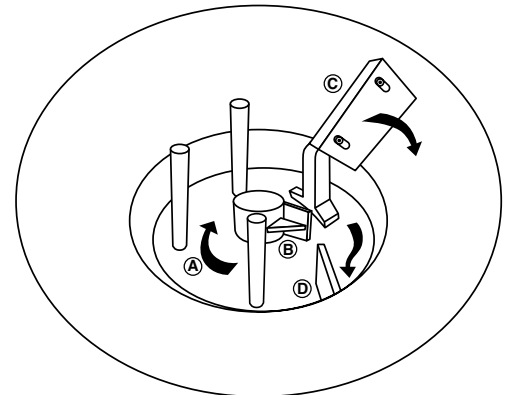
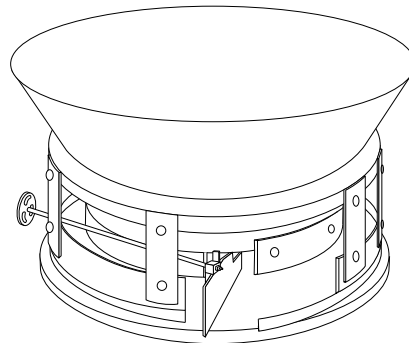

- A - Direction of Rotating table
- B - Stationary plow to clean inner area of table
- C - Rotating scraper blade
- D - Adjustable plow directing material flow out of table feeder

Please inquire about our free testing.

Visit our website at: [www.lancasterproducts.com](http://www.lancasterproducts.com)

All information is subject to change without notice.  
Parts and assembly made in the U.S.A.

Pub. 700/10

**LANCASTER®  
PRODUCTS**

Mfd. by Kercher Industries, Inc.

**1.800.447.7351**  
outside U.S. **717.273.2111**

Fax: 717.273.2967

email: [info@lancasterproducts.com](mailto:info@lancasterproducts.com)  
[www.lancasterproducts.com](http://www.lancasterproducts.com)