

Hudson

BEARINGS

Air Cargo Ball Transfers



HudsonBearings.com



THE HUDSON BEARINGS

Load Capacity Advantage

850 lbs | 385 kg

Load Capacity Per Unit

Proprietary Inner Race Geometry

Our proprietary Inner Race geometry provides unparalleled load capacity.

Not Just a Screen

Our inner race is a cup, covering the majority of the housing's interior while still allowing dirt and debris expulsion.

Stainless Steel Inner Race

Our stamped inner race has a smooth rolling, high-RMS Factor surface.



Large Stock. Always.

Our 25,000 square ft. state-of-the-art facility allows for in-house CNC turning and milling, screw machining, and stamping for high-volume production.

Equally Distributed Load

Our inner race geometry allows the support balls to be evenly distributed when under load.



*Inner Race after
3,800 lbs / 1,700 kg rolling load
test. No damage to Weep Holes.*

No Ganging at Bottom While Under Load

Support balls will not gang when under load to allow for continuous smooth rolling.

Multiple Weep Holes

Multiple weep holes in Hudson Bearings' Ball Transfers do not impact load capacity or structural integrity.



EXTREME LOAD TESTING

Putting the inner race to the test.

STATIC LOAD TEST

15,000 lbs | 6,800 kg
Without Failure

Our Air Cargo Inner Race product withstood over 15,000 lbs / 6,800 kg of static load without failure.



ROLLING LOAD TEST

3,800 lbs | 1,700 kg
Without Failure

Our Air Cargo Inner Race product withstood over 3,800 lbs. / 1,700 kg of rolling load without failure.



*Inner Race after
15,000 lbs / 6,800 kg
static load test.*

Test Video and Additional Documentation available upon request.
info@hudsonbearings.com

Trusted



UPS WORLDPORT

Following a no-cost robust Holiday-season in-service testing program, Hudson Bearings became the preferred supplier for UPS Worldport and other locations via the Ariba Network.



Hudson Bearings Air Cargo Ball Transfers are trusted by end users and integrators worldwide.

INCLUDING:



CARBON FREIGHT



U.S. AIR FORCE



SANKI



IAUS
INTERNATIONAL AUTOMATED SYSTEMS



GSP AIRPORT



QANTAS



CARBON FREIGHT

We worked hand-in-hand with Carbon Freight to develop a new kind of forklift-able slave pallet that enhances moving ULDs. In service now with United Airlines.

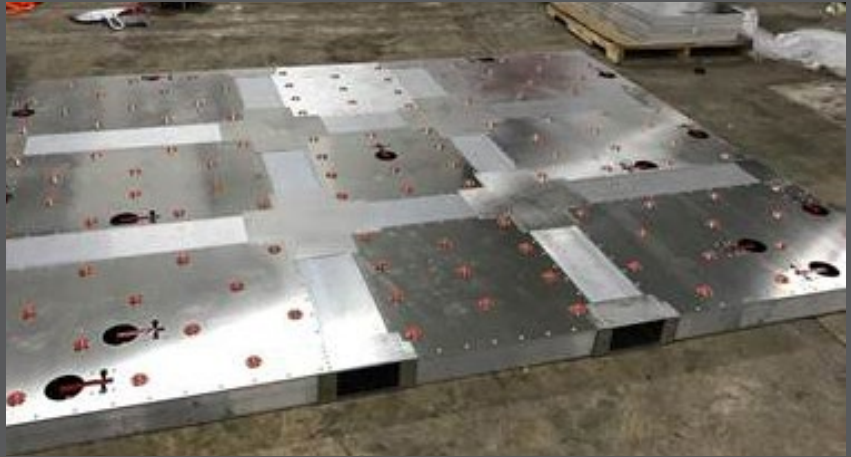

U.S. AIR FORCE

We are proud to be an approved USAF supplier with ball transfers deployed at multiple Air Force locations worldwide, including cold storage at Travis Air Force base.

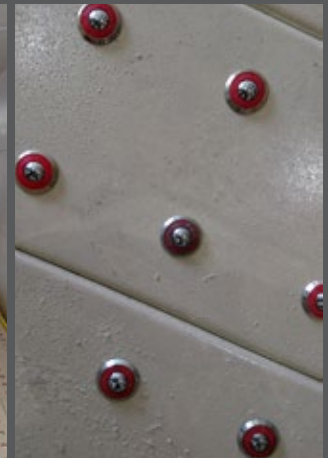

Custom Configurations and Private Labeling

Hudson Bearings developed an all stainless steel grooved housing with clip for a Quantus Airlines dolly.

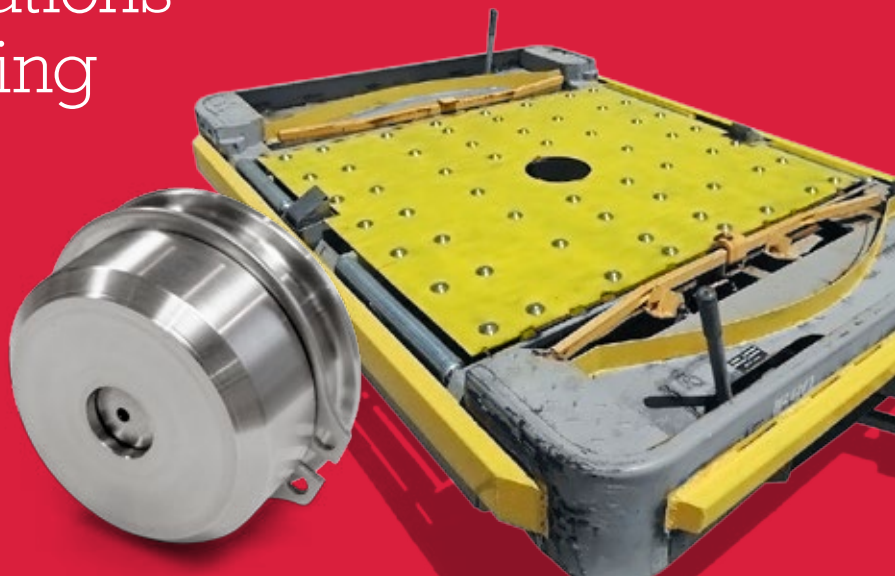

INTERCHANGEABLE

Flying Saucer Ball Transfers

Our interchangeable Air Cargo Flying saucers are great for empty ULDs, air cargo dollies, or lighter loads.



275 lbs | 125 kg
FSBT 1-1/4 SS MW



120 lbs | 55 kg
FSBT 1 SS MW



Multiple Weep Holes
Come Standard

OUR NEW LINE OF Air Casters

Contact us for more details.
info@hudsonbearings.com

550 lbs | 250 kg
Load Capacity



HB-ACD-58



HB-ACDT-58







HB-ACR-58



HB-ACRT-58

Product Specs. & Dimensions

| Product / Code | Load Capacity | Housing | Housing Finish | Cap | Main & Support Ball | Max Temp. Rating | Stainless Steel Inner Race | Multiple Weep Holes |
|---|-------------------|----------------------------|----------------------------|-----------------------------|----------------------------|------------------|----------------------------|---------------------|
|  Heavy Duty Carbon Steel Ball Transfer HDBT 1-3/16 CS/SS YZ IR MW | 850 lbs 385 kg | Carbon Steel | Yellow Zinc | Polypropylene | 400 Series Stainless Steel | 250° F | ✓ | ✓ |
|  Heavy Duty Carbon Steel Ball Transfer w/ Metal Cap HDBTM 1-3/16 CS/SS YZ IR MW | 850 lbs 385 kg | Carbon Steel | Yellow Zinc | Carbon Steel w/ Zinc Finish | 400 Series Stainless Steel | 400° F | ✓ | ✓ |
|  Heavy Duty Stainless Steel Ball Transfer w/ Metal Cap HDBTM 1-3/16 SS IR/MW | 850 lbs 385 kg | 400 Series Stainless Steel | 400 Series Stainless Steel | 400 Series Stainless Steel | 400 Series Stainless Steel | 400° F | ✓ | ✓ |

| Product Code | Load Capacity | Housing | Housing Finish | Mounting Holes | Main & Support Balls | Max Temp. Rating | Felt Seal | Multiple Weep Holes |
|---|-------------------|--------------|----------------|------------------|----------------------------|------------------|-----------|---------------------|
|  1" Stainless Steel Flying Saucer Ball Transfer FSBT 1 SS MW | 120 lbs 55 kg | Carbon Steel | Yellow Zinc | 2 Mounting Holes | 400 Series Stainless Steel | 400° F | Optional | ✓ |
|  1.25" Stainless Steel Flying Saucer Ball Transfer FSBT 1-1/4 SS MW | 275 lbs 125 kg | Carbon Steel | Yellow Zinc | 3 Mounting Holes | 400 Series Stainless Steel | 400° F | Optional | ✓ |

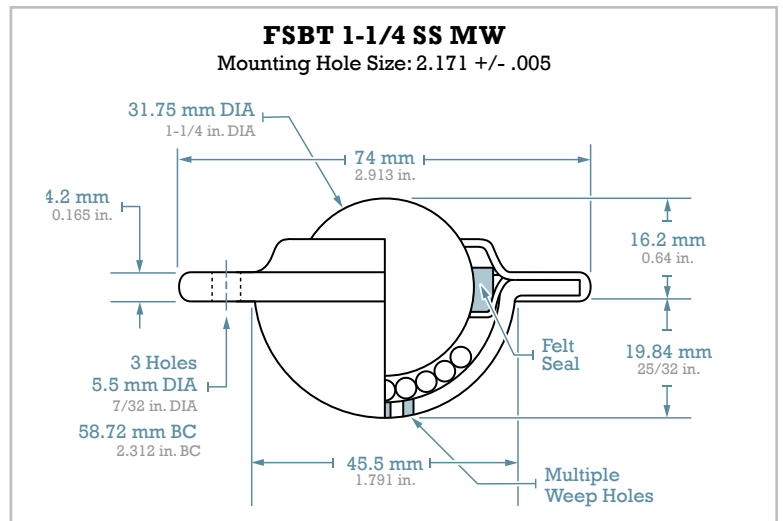
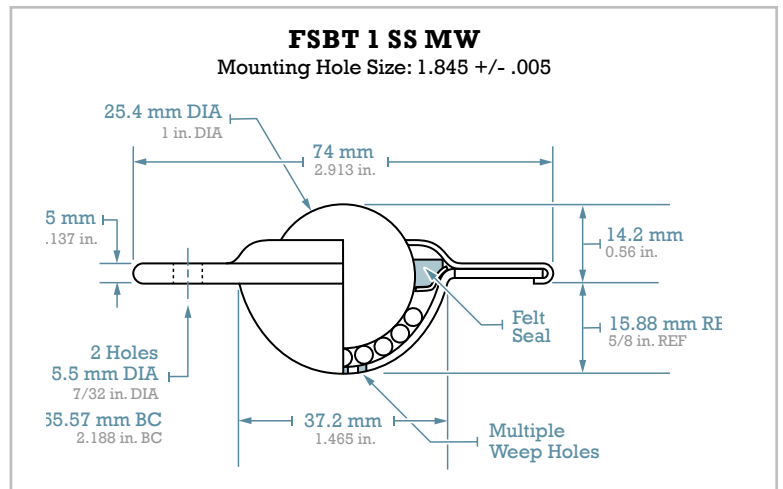
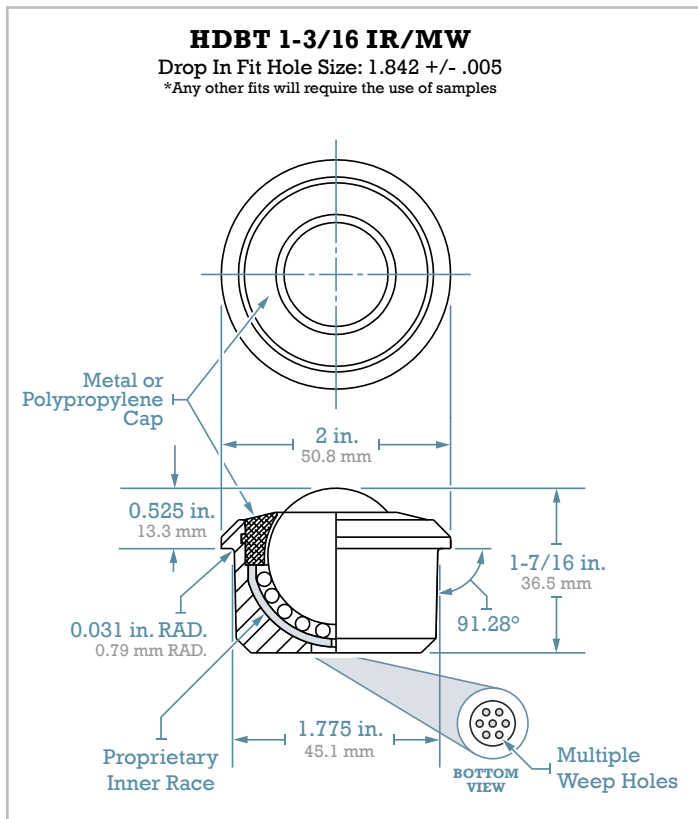

Individual Product Dimension files are available online.
CAD Drawings available upon request.

info@hudsonbearings.com

All product designs subject to change, please verify accuracy of dimensions before fabrication.

ABOUT HUDSON BEARINGS

Hudson Bearings is a manufacturer based in the United States. Since 1969, we have been pioneer in the ball transfer industry.

Hudson's product line includes an industry leading array of ball transfer products including an air cargo specific product line that can be customized and sold worldwide.

In 2016 Hudson acquired TurboSocket, original damaged fastener removal tool, further enhancing our product line.



INDEPENDENT & MULTICHANNEL DISTRIBUTORS



OEM & SYSTEM INTEGRATORS



Hudson BEARINGS

HudsonBearings.com

Phone: 614-846-2090

Fax: 888-447-0505

7060 Huntley Road,
Columbus, OH 43229
United States

