

Technical Specification Sheet

**MT10 Single Circuit** [VSL28]  
[680kg]

Avoid the strain of lifting dense stone with this powerful MT10 stone slab vacuum lifter.

Offering 680kg of lifting power, the MT10 vacuum lifter is a below-the-hook machine highly suited to stone yards, stone wholesalers, masonry workshops and more.

Stone slabs can be quickly lifted onto a cutting table thanks to the manual tilting function which can safely shift stone from an upright to flat position.

The MT10 features a constant running vacuum pump designed to lift both porous and non-porous stone including marble, granite, slate, limestone, sandstone and more.



**Features**

- 680kg lifting capacity
- Single vacuum circuit
- Lifts different stone finishes: flame-cut, sawn, honed, polished and more
- Manual tilting from upright to horizontal
- Vacuum pump is remotely mounted
- Each pad can be isolated for lifting irregular shapes
- Mains powered
- 240v AC constant running pump
- Weight of lifter: 54kg
- 10 x 280mm Ø foam lipped suction pads
- Low pressure audio-visual alarm
- Ref: VSL28

**Dimensions**

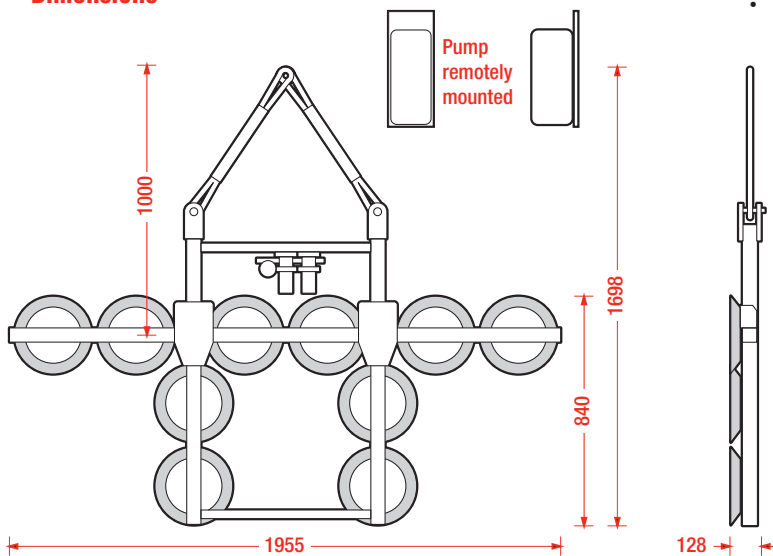

**HIRE OR PURCHASE TODAY - CALL OUR SPECIALIST TEAM ON:**

North: +44 (0)161 683 2580 - South: +44 (0)1844 202 071 - Scotland: +44 (0)1698 824444

[www.ggrgroup.com](http://www.ggrgroup.com)