



Technical Specification Sheet

PT4 Single Circuit (VSL31)

[270kg]

Effortlessly lift and tilt polished and rough-cut stone slabs with the specialist PT4 Aero vacuum lifter. Boasting 90 degree air-powered tilting, the PT4 makes light work of heavy stone lifting, helping to reduce the strain from manual handling.

Delivering 270kg of lifting power, the PT4 vacuum lifter is a great way to lift and shift porous and smooth stone around a busy masonry workshop or stone yard. The sliding pad mounts can be adjusted and isolated to suit different shaped stone slabs.

This versatile lifter has a single circuit, air-powered Venturi system and soft rubber vacuum cups, designed to lift both porous and non-porous stone types.

Compressed air supply is required.

Features

- 270kg lifting capacity
- Air powered tilting from vertical to horizontal
- Sliding pad mounts can be individually isolated
- Weight of lifter: 68kg
- 4 x 280mm Ø foam lipped suction pads
- Audio-visual low pressure alarm
- Ref: VSL31

Dimensions

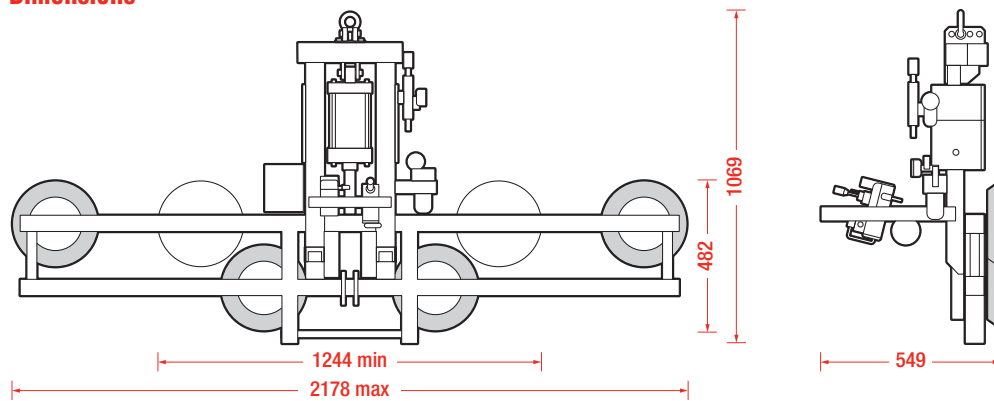

HIRE OR PURCHASE TODAY - CALL OUR SPECIALIST TEAM ON:

North: +44 (0)161 683 2580 - South: +44 (0)1844 202 071 - Scotland: +44 (0)1698 824444

www.ggrgroup.com