

## Technical Specification Sheet

# GL-UMC 1000 Glazing Manipulator Head

[1000kg]

The innovative GL-UMC1000 has been developed to handle both flat and curved glass for ultimate flexibility. Combined with our URW-706 UNIC spider crane, this robotic attachment allows for easy glazing at height and is capable of lifting and manipulating large glass units of up to 1000kg.

Depending on the application, the GL-UMC1000 can be configured to lift flat or convex and concave curved glass. The attachment is battery powered and its radio remote controlled electric actuators allow for 95° rotation, 40° head slew left and right and 60° up and down tilt for precise glass moving.

The GL-UMC1000's capacity and versatility makes it suitable for a wide range of projects. Additionally, its independent power system and safety features including audio-visual low vacuum warnings, make it one of the most advanced products in its category.

Compatible with GGR's URW-706 and exclusively available to hire or purchase from GGR Group Ltd.

## Features

- Capacity: 1000kg (flat), 800kg (curved)
- Dual circuit vacuum system with vacuum gauge, reserve tank and non-return valve for each circuit
- Compatible with UNIC models: URW-706
- Innovative head design allows unit to be manipulated with ease through:
  - 40° left and right from centre
  - 60° up and down from centre
  - 95° rotation
- Audio-visual low vacuum warning
- Extension arms for lifting larger flat loads
- Power supply: 24V rechargeable battery
- Weight: 230kg (12 pads), 222kg (10 pads)
- Not suitable for use in the rain
- Ref: VGL 105



**HIRE OR PURCHASE TODAY - CALL OUR SPECIALIST TEAM ON:**

North: +44 (0)161 683 2580 - South: +44 (0)1844 202 071 - Scotland: +44 (0)1698 824 444

[www.ggrgroup.com](http://www.ggrgroup.com)

## Technical Information

<b>Safe working load</b> (smooth, clean surface at 60% vacuum)	capacity:	1000kg	600kg	800kg
<b>Number of suction cups</b>	cups:	10 (flat with extension arms)	6 (flat)	12 (curved)
<b>Suction cup</b>	description:	black rubber, not abrasion resistant, heat resistant up to 100°F		
<b>Suction cup diameter</b>	diameter:	300mm		
<b>Suitable for lifting</b>	material properties:	gastight / non-porous		
	surface:	smooth		
	example:	glass, plastic boards, ceramic plates, sheet metals, coated boards		
<b>Length of lifter</b>	approx:	2280mm (flat)	1500mm (curved)	
<b>Weight of lifter</b>	approx:	222kg (10 flat)	230kg (curved)	
<b>Powered Head Tilt</b>	tilt:	60° up and down		
<b>Powered Head Slew</b>	slew:	40° left & right		
<b>Powered Pad Frame Rotation</b>	rotation:	95°		
<b>Vacuum system</b>	dual circuit:	2 pumps, 2 vacuum reserve tanks		
<b>Power Requirements</b>	head & vacuum:	On-board battery pack powers both robotic head and vacuum system operation. Rechargeable by 110/240v charger		
<b>Standard accessories</b>	standard:	Radio remote control, four extension arms with four pads, battery gauge, green "safe to lift" light		
<b>Optional accessories</b>	optional:	External battery pack and charger for radio remote control		

## Dimensions

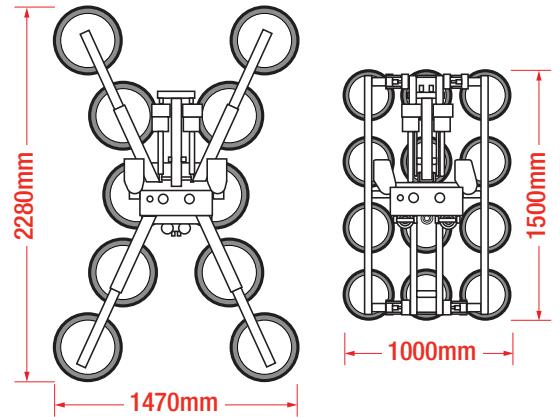

**HIRE OR PURCHASE TODAY - CALL OUR SPECIALIST TEAM ON:**

North: +44 (0)161 683 2580 - South: +44 (0)1844 202 071 - Scotland: +44 (0)1698 824 444