

Technical Specification Sheet

Frame Extensions For Woods Powr-Grip Vacuum Lifters (WGGR151)

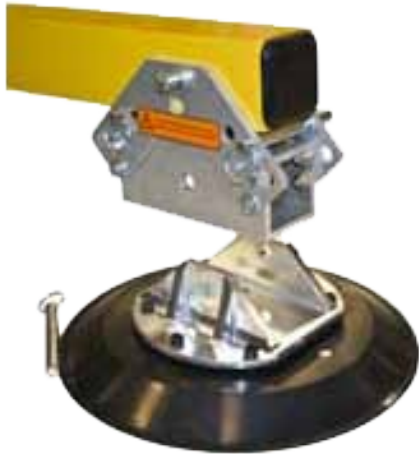

Window mullions and other obstructions are no longer a problem thanks to these clever frame extensions with moveable pad mounts.

Designed to complement our MRT4 and MRTA6 vacuum lifters, the frame extensions help overcome obstructions on the contact surface. The extensions are fast and simple to install using hitch pins, and each mount extension is adjustable to match the specific application.

The frame extensions are designed for frames with a tube width of 51mm or 63mm. Different sized extension tubes can also be purchased if you are looking to extend the moveable pad mounts to different distances from the pad frame.

Please note the frame extensions will alter the lifting capacity of the machine; please contact our team for further advice.

Model	Safe working load with minimum extension (65mm)	Safe working load with maximum extension (65mm)
MRT4	167kg	147kg
MRTA6	440kg	421kg

Technical Specifications

Pad Frame Tube Width	(A) 51mm	(B) 51mm	(C) 63mm	(D) 63mm
Extension Tube Dimensions	51 x 51mm	51 x 76mm	63 x 63mm	63 x 89mm
Minimum-Maximum Extension Distance	52 - 71mm	78 - 97mm	65 - 84mm	90 - 110mm

Dimensions

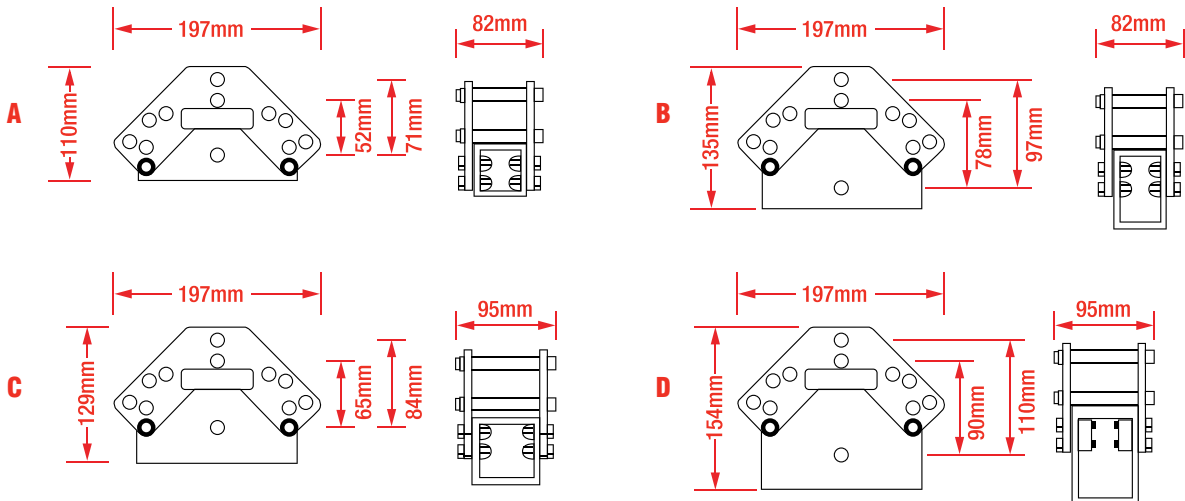

HIRE OR PURCHASE TODAY - CALL OUR SPECIALIST TEAM ON:

North: +44 (0)161 683 2580 - South: +44 (0)1844 202 071 - Scotland: +44 (0)1698 824444

www.ggrgroup.com