

GGB HI-EX[®]

Metal-Polymer Superior Performance Bearing Solutions
for Lubricated Applications

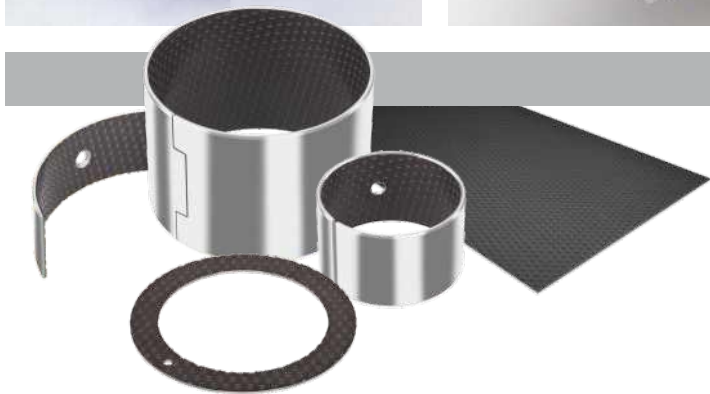

The Global Leader
in High Performance Bearing Solutions



an EnPro Industries company

GGB World Class

All the products described in this handbook are manufactured under DIN EN ISO 9001, ISO/TS 16949, OHSAS 18001 and ISO 14001 approved management systems.

All Certificates can be downloaded as PDF files from our website www.ggbearings.com.

In addition GGB North America has been certified AS9100 revision B complying with the requirements of aerospace industry's quality management system for the manufacture of metal-backed bearings and filament wound bearings and washers.

AMERICA



FRANCE



GERMANY

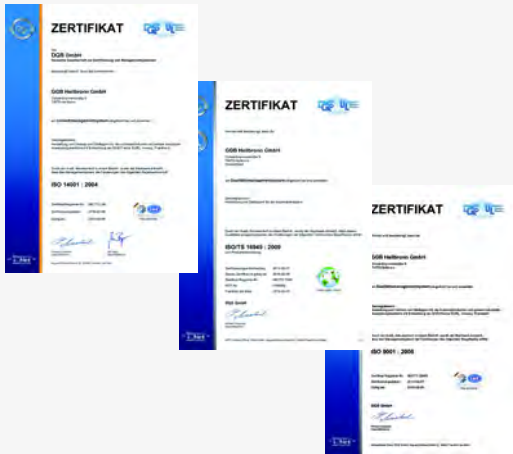

BRAZIL

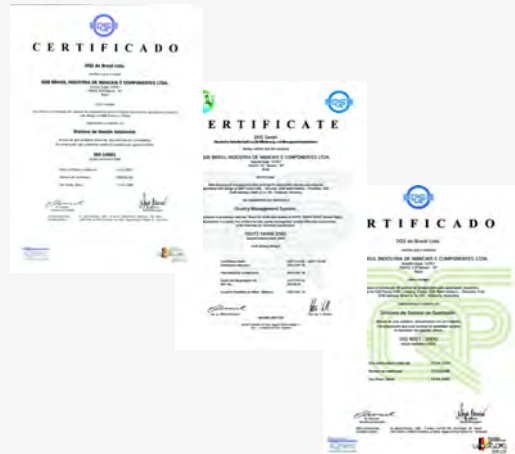

SLOVAKIA



CHINA



Content

GGB World Class	2	6 Bearing Assembly	21
1 Introduction	4	6.1 Dimensions and Tolerances ..	21
1.1 Characteristics and Advantages	4	6.2 Tolerances for minimum clearance	21
2 Structure	4	Grease lubrication	21
2.1 Basic Forms	5	Fluid Lubrication	23
3 Properties	6	Allowance for Thermal Expansion	23
3.1 Physical Properties	6	6.3 Counterface Design	24
3.2 Chemical Properties	6	6.4 Installation	25
4 Lubrication and Friction .	7	Fitting of Bushes	25
4.1 Dry operation	7	Insertion Forces	25
4.2 Choice of Lubricant	7	Alignment	26
Grease	7	Sealing	26
Oil	7	Axial Location	26
Non lubricating fluids	7	Fitting of Thrust Washers	26
4.3 Friction	9	Slideways	27
4.4 Lubricated Environments	9	7 Machining	28
Lubrication	9	7.1 Machining Practice	28
4.5 Characteristics of Fluid Lubricated HI-EX Bearings ...	10	7.2 Boring	28
4.6 Design Guidance for Fluid Lubricated Applications	10	7.3 Reaming	29
4.7 Wear Rate and Re-lubrication Intervals with Grease lubrication	12	7.4 Broaching	29
Fretting Wear	12	7.5 Vibrobroaching	30
5 Design Factors	13	7.6 Modification of components ..	30
5.1 Specific Load	13	7.7 Drilling Oil Holes	30
Specific Load Limit	13	7.8 Cutting Strip Material	30
5.2 Sliding Speed	14	8 Electroplating	31
Continuous Rotation	14	HI-EX Components	31
Oscillating Movement	14	Mating Surfaces	31
5.3 pv Factor	15	9 Standard Products	32
5.4 Load	15	9.1 PM-HI-EX cylindrical bushes ..	32
Type of Load	15	9.2 MB-HI-EX cylindrical bushes .	39
5.5 Temperature	17	9.3 HI-EX Thrust Washers	44
5.6 Mating Surface	17	9.4 HI-EX Strip	44
5.7 Bearing Size	18	10 Test Methods	45
5.8 Estimation of Bearing Service Life with Grease Lubrication	18	10.1 Measurement of Wrapped Bushes	45
Calculation Parameters	18	Test A of ISO 3547 Part 2	45
Estimate Re-greasing Interval ..	19	Test B (alternatively to Test A) ..	45
Oscillating Motion and Dynamic Loads	19	Test C	45
5.9 Worked Examples	20	Test D	45
		11 Data Sheet for bearing design	46
		Formula Symbols and Designations	47

1 Introduction

The purpose of this handbook is to provide comprehensive technical information on the characteristics of HI-EX™ bearings. The information given, permits designers to establish the correct size of bearing required and the expected life and performance. GGB Research and Development services are available to assist with unusual design problems.

Complete information on the range of HI-EX standard products is given together with details of other HI-EX products.

GGB is continually refining and extending its experimental and theoretical knowledge and, therefore, when using this brochure it is always worthwhile to contact the Company should additional information be required.

Customers are advised to carry out prototype testing wherever possible.

1.1 Characteristics and Advantages

- HI-EX provides maintenance free operation
- HI-EX has a high pv capability
- HI-EX exhibits low wear rate
- Seizure resistant
- Suitable for temperatures from -150 °C to +250 °C
- High static and dynamic load capacity
- HI-EX polymer bearing lining has good chemical resistance
- No water absorption and therefore dimensionally stable
- Compact and light
- Suitable for rotating, oscillating, reciprocating and sliding movements
- HI-EX bearings are prefinished and require no machining after assembly
- Suitable for use with low viscosity and low lubricant fluids.

2 Structure

HI-EX is a composite bearing material developed specifically to operate with marginal lubrication and consists of three bonded layers: a steel backing strip and a sintered porous bronze matrix, impregnated and overlaid with a PEEK (polyether ether ketone) polymer bearing material, containing fillers including PTFE (polytetrafluorethylene).

The steel backing provides mechanical strength and the bronze interlayer provides a strong mechanical bond for the lining. This construction promotes dimensional stability and improves thermal conductivity, thus reducing the temperature at the bearing surface.

For grease lubricated applications HI-EX is manufactured with a polymer overlay thickness above the bronze sinter layer of 0.30 mm nominal, and the bearing surface is provided with a uniform pattern of indents. These serve as a reservoir for the grease

and are designed to provide the optimum distribution of the lubricant over the bearing surface (e.g. PM2020HX).

For fluid lubricated applications where the bearing surface may be required to be machined subsequent to assembly, HI-EX is manufactured with a polymer overlay thickness above the bronze sinter layer of 0.30 mm nominal, and the indent pattern omitted from the bearing surface (e.g. PM2020HXU).

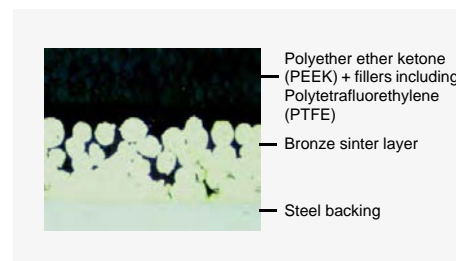

Fig. 1: HI-EX-microsection

2.1 Basic Forms

HI-EX is **not** available from stock and is manufactured only to order as follows:

Standard Components

These products are manufactured to International, National or GGB standard designs:

- Cylindrical Bushes
 - **PM** pre finished **metric** range, not machinable in situ, for use with standard journals finished to h6-h8 limits.
 - **MB** machinable **metric** range, with an allowance for machining in situ.
- Thrust Washers
- Strip Material



Fig. 2: Standard components

Non Standard Components

These products are manufactured to customers' requirements with or without GGB recommendations, and include for example:

- Modified Standard Components
- Half Bearings
- Flat Components
- Pressings
- Stampings



Fig. 3: Non standard components

3 Properties

3.1 Physical Properties

	Characteristic	Symbol	Value HI-EX	Unit	Comments
Physical Properties	Thermal Conductivity	λ	52	W/mK	
	Coefficient of linear thermal expansion :				
	parallel to surface	α_1	11	10^{-6} K	
	normal to surface	α_2	29	10^{-6} K	
	Maximum Operating Temperature	T_{\max}	250	$^{\circ}\text{C}$	
	Minimum Operating Temperature	T_{\min}	-150	$^{\circ}\text{C}$	
Mechanical Properties	Compressive Yield Strength	σ_c	380	MPa	measured on disc 5 mm diameter x 2.45 mm thick.
	Maximum Load				
	Static	$\rho_{\text{dyn,max}}$	70	MPa	
	Dynamic	ρ_D	$>10^9$	Ωcm	
Electrical Properties	Volume resistivity of PEEK lining	λ	52	W/mK	

Table 1: Physical, mechanical and electrical properties of HI-EX

3.2 Chemical Properties

The following table provides an indication of the resistance of HI-EX to various chemical media. It is recommended that the chemical resistance is confirmed by testing if possible.

+	Satisfactory: Corrosion damage is unlikely to occur.
o	Acceptable: Some corrosion damage may occur but this will not be sufficient to impair either the structural integrity or the tribological performance of the material.
-	Unsatisfactory: Corrosion damage will occur and is likely to affect either the structural integrity and/or the tribological performance of the material.

	Chemical	%	$^{\circ}\text{C}$	Rating
Strong Acids	Hydrochloric Acid	5	20	-
	Nitric Acid	5	20	-
	Sulphuric Acid	5	20	-
Weak Acids	Acetic Acid	5	20	-
	Formic Acid	5	20	-
Bases	Ammonia	10	20	o
	Sodium Hydroxide	5	20	o
Solvents	Acetone		20	+
	Carbon Tetrachloride		20	+
Lubricants and fuels	Paraffin		20	+
	Gasolene		20	+
	Kerosene		20	+
	Diesel fuel		20	+
	Mineral Oil		70	+
	HFA-ISO46 High Water fluid		70	+
	HFC-Water-Glycol		70	+
	HFD-Phosphate Ester		70	+
	Water		20	o
	Sea Water		20	-

Table 2: Chemical resistance of HI-EX

4 Lubrication and Friction

4.1 Dry operation

HI-EX will operate satisfactorily without lubrication under light duty running conditions at pv factors below 0.01 MPa x m/s

and sliding speeds below 2.5 m/s. The wear performance should be confirmed by testing if possible.

4.2 Choice of Lubricant

HI-EX will generally be lubricated, the choice of lubricant depending upon:

- pv and sliding speed
- the stability of the lubricant under the operating conditions.

Grease

The performance ratings of different types of grease are indicated in Table 3. Greases containing EP additives or significant additions of graphite or MoS₂ are not generally recommended for use with HI-EX.

HI-EX is able to withstand environmental temperatures beyond those generally suitable for grease lubrication and the performance is therefore likely to be limited by

the lubricant and not by the bearing material. For environmental temperatures above 80 °C suitability of the grease should be established by test and a silicone oil base or high temperature grease is recommended. For applications above 150 °C pv values should be limited to below 1.0 N/mm² x m/s and re-lubrication intervals should not exceed 500 hours.

Oil

HI-EX is recommended for use with oil lubrication. HI-EX is compatible with mineral oils up to 150 °C and is resistant to the oxidation products which may occur with mineral oils at temperatures above 115 °C.

Degradation of oils is likely to occur following extended exposure to high temperatures and synthetic lubricants are recommended under these circumstances.

Non lubricating fluids

HI-EX has been found to perform satisfactorily with low viscosity and non lubricating fluids such as polyethylene glycol and polyglycol lubricants, water-oil emulsion, shock-absorber oils, kerosene and water.

In general, the fluid will be acceptable if it does not chemically attack the PEEK lining or the porous bronze interlayer. Chemical resistance data are given in Table 2.

Where there is doubt about the suitability of a fluid, a simple test is to submerge a

sample of HI-EX material in the fluid for two to three weeks at 15-20 °C above the operating temperature. The following will usually indicate that the fluid is not suitable for use with HI-EX.

- A significant change in the thickness of the HI-EX material,
- A visible change in the bearing surface from polished to matt.
- A visible change in the microstructure of the bronze interlayer

4 Lubrication and Friction

+	Recommended
o	Satisfactory
-	Not recommended
NA	Data not available

Manufacturer	Grade	Type		Rating
		Oil	Thickener	
BP	Energrease LS2	Mineral	Lithium Soap	+
	Energrease LT2	Mineral	Lithium Soap	+
	Energrease FGL	Mineral	Non Soap	o
	Energrease GSF	Synthetic	NA	o
Century	Lacerta ASD	Mineral	Lithium/Polymer	o
	Lacerta CL2X	Mineral	Calcium	-
Dow Corning	Molykote 55M	Silicone	Lithium Soap	o
	Molykote PG65	PAO	Lithium Soap	+
	Molykote PG75	Synthetic/Mineral	Lithium Soap	o
	Molykote PG602	Mineral	Lithium Soap	o
Elf	Rolexa.1	Mineral	Lithium Soap	+
	Rolexa.2	Mineral	Lithium Soap	o
	Epexelf.2	Mineral	Lithium/Calcium Soap	-
Esso	Andok C	Mineral	Sodium Soap	o
	Andok 260	Mineral	Sodium Soap	o
	Cazar K	Mineral	Calcium Soap	-
Mobil	Mobilplex 47	Mineral	Calcium Soap	-
	Mobiltemp 1	Mineral	Non Soap	o
Rocol	BG622	White Mineral	Calcium Soap	o
	Sapphire	Mineral	Lithium Complex	-
	White Food Grease	White Oil	Clay	-
Shell	Albida R2	Mineral	Lithium Complex	+
	Axinus S2	Mineral	Lithium	o
	Darina R2	Mineral	Inorganic Non Soap	+
	Stamina U2	Mineral	Polyurea	-
	Tivela A	Synthetic	NA	o
Total	Aerogrease	Synthetic	NA	+
	Multis EP2	NA	Lithium	+

Table 3: Performance of greases

4.3 Friction

The coefficient of friction of lubricated HI-EX depends upon the actual operating conditions as indicated in section 4.4.

Where frictional characteristics are critical to a design they should be established by prototype testing.

4.4 Lubricated Environments

The following sections describe the basics of lubrication and provide guidance on the

application of HI-EX in such environments.

Lubrication

There are three modes of lubricated bearing operation which relate to the thickness of the developed lubricant film between the bearing and the mating surface.

These three modes of operation depend upon:

- Bearing dimensions
- Clearance
- Load and Speed
- Lubricant Viscosity and Flow

Hydrodynamic lubrication

Characterised by:

- Complete separation of the shaft from the bearing by the lubricant film
- Very low friction and no wear of the bearing or shaft since there is no contact
- Coefficients of friction of 0.001 to 0.01

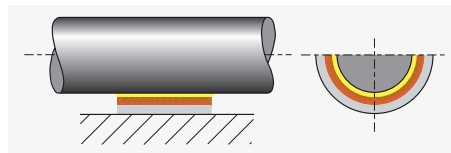

Fig. 4: Hydrodynamic lubrication

Hydrodynamic conditions occur when

$$(4.4.1) \quad p \leq \frac{v \cdot \eta}{7.5} \cdot \frac{B}{D_i} \quad [\text{MPa}]$$

Mixed film lubrication

Characterised by:

- Combination of hydrodynamic and boundary lubrication.
- Part of the load is carried by localised areas of self pressurised lubricant and the remainder supported by boundary lubrication.
- Friction and wear depend upon the degree of hydrodynamic support developed.
- HI-EX provides low friction and high wear resistance to support the boundary lubricated element of the load.

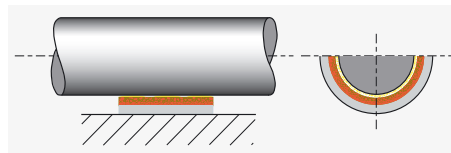

Fig. 5: Mixed film lubrication

Boundary lubrication

Characterised by:

- Rubbing of the shaft against the bearing with virtually no lubricant separating the two surfaces.
- Bearing material selection is critical to performance.
- Shaft wear is likely due to contact between bearing and shaft.
- The excellent properties of HI-EX material minimises wear under these conditions.
- The dynamic coefficient of friction with HI-EX is typically 0.02 to 0.15 under boundary lubrication conditions.

- The static coefficient of friction with HI-EX is typically 0.05 to 0.20 under boundary lubrication conditions.

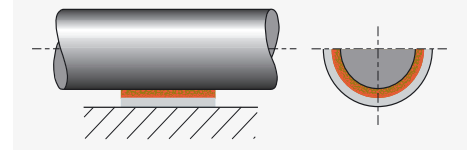

Fig. 6: Boundary lubrication

4.5 Characteristics of Fluid Lubricated HI-EX Bearings

HI-EX is particularly effective in the most demanding of lubricated applications

where full hydrodynamic operation cannot be maintained, for example:

• High load conditions

In highly loaded applications operating under boundary or mixed film conditions HI-EX shows excellent wear resistance.

• Start up and shut down under load

With insufficient speed to generate a hydrodynamic film the bearing will operate under boundary or mixed film conditions.

- HI-EX minimises wear

• Sparse lubrication

Many applications require the bearing to operate with less than the ideal lubricant supply, typically with splash or mist lubrication only.

The PEEK lining of HI-EX has low thermal conductivity relative to conventional metallic bearings, and therefore depending upon the operating conditions may require a greater lubricant supply to remove the generated heat in the bearing.

- HI-EX shows greater wear resistance than conventional metallic bearings.

4.6 Design Guidance for Fluid Lubricated Applications

Fig. 7, Page 11 shows the three lubrication regimes discussed above plotted on a

graph of sliding speed vs the ratio of specific load to lubricant viscosity.

In order to use Fig. 7

- Using the formulae in Section 5
 - Calculate the specific load p
 - Calculate the shaft surface speed v

- Using the viscosity temperature relationships presented in Table 4.
 - Determine the viscosity in centipoise of the lubricant.

Note:

Viscosity is a function of operating temperature. If the operating temperature of the

fluid is unknown, a provisional temperature of 25 °C above ambient can be used.

Area 1 of Fig. 7

The bearing will operate with boundary lubrication.

The pv factor will be the major determinant of bearing life.

If $epv/\eta \leq 0.2$ then

$$(4.6.1) \quad L_H = \frac{2250}{\left(\frac{epv}{\eta}\right)^{0.5}} \cdot a_Q \cdot a_T \cdot a_S \quad [h]$$

If $0.2 < epv/\eta \leq 1.0$ then

$$(4.6.2) \quad L_H = \frac{1000}{\left(\frac{epv}{\eta}\right)} \cdot a_Q \cdot a_T \cdot a_S \quad [h]$$

Area 2 of Fig. 7

The bearing will operate with mixed film lubrication.

pv factor is no longer a significant parameter in determining the bearing life.

Area 3 of Fig. 7

The bearing will operate with hydrodynamic lubrication. Bearing wear will be determined only by the cleanliness of the

Area 4 of Fig. 7

- These are the most demanding operating conditions.
- The bearing is operated under either high speed or high bearing load to viscosity ratio, or a combination of both.
- These conditions may cause

HI-EX bearing performance can be estimated from the following:

Calculate Effective pv Factor from Section 5.8.

If $epv/\eta > 1.0$ then

$$(4.6.3) \quad L_H = \frac{1000}{\left(\frac{epv}{\eta}\right)^2} \cdot a_Q \cdot a_T \cdot a_S \quad [h]$$

epv see (5.8.2), Page 19

HI-EX bearing performance will depend upon the nature of the fluid and the actual service conditions.

lubricant and the frequency of start up and shut down.

- excessive operating temperature
- and/or high wear rate.
- Bearing performance may be improved:
 - by use of unindented HI-EX lining
 - by the addition of one or more grooves to the bearing
 - by shaft surface finish $< 0.05 [\mu m R_a]$.

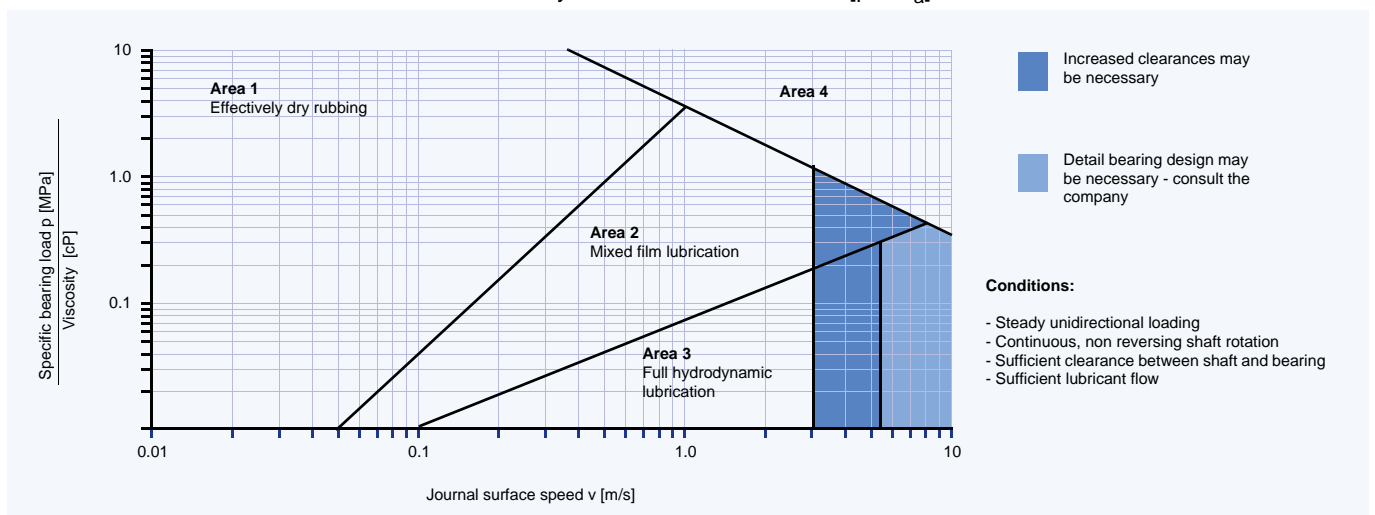

Fig. 7: Design guide for lubricated application

4 Lubrication and Friction

Temperature [°C]	Viscosity [cP]														
	0	10	20	30	40	50	60	70	80	90	100	110	120	130	140
ISO VG 32	310	146	77	44	27	18	13	9.3	7.0	5.5	4.4	3.6	3.0	2.5	2.2
ISO VG 46	570	247	121	67	40	25	17	12	9.0	6.9	5.4	4.4	3.6	3.0	2.6
ISO VG 68	940	395	190	102	59	37	24	17	12	9.3	7.2	5.8	4.7	3.9	3.3
ISO VG 100	2110	780	335	164	89	52	33	22	15	11.3	8.6	6.7	5.3	4.3	3.6
ISO VG 150	3600	1290	540	255	134	77	48	31	21	15	11	8.8	7.0	5.6	4.6
Diesel oil	4.6	4.0	3.4	3.0	2.6	2.3	2.0	1.7	1.4	1.1	0.95				
Petrol	0.6	0.56	0.52	0.48	0.44	0.40	0.36	0.33	0.31						
Kerosene	2.0	1.7	1.5	1.3	1.1	0.95	0.85	0.75	0.65	0.60	0.55				
Water	1.79	1.30	1.0	0.84	0.69	0.55	0.48	0.41	0.34	0.32	0.28				

Table 4: Viscosity data

4.7 Wear Rate and Re-lubrication Intervals with Grease lubrication

At specific bearing loads below 100 MPa a grease lubricated HI-EX bearing shows only small bedding-in wear of about 0.0025 mm. This is followed by little wear during the early part of the bearing life until the lubricant becomes exhausted and the wear rate increases. If the bearing is regreased before the rate of wear starts to increase rapidly the material will continue to function satisfactorily with little wear. Fig. 8 shows the typical wear pattern.

Under specific loads above 100 MPa the initial bedding-in wear is greater, typically about 0.025 mm, followed by a decreasing wear rate until the bearing exhibits a similar wear/life relationship to that shown in Fig. 8.

The useful life of the bearing is limited by wear in the loaded area. If this wear exceeds 0.15mm the grease capacity of the indents is reduced and more frequent regreasing of the bearing will be required.

Fretting Wear

Oscillating movements of less than the dimensions of the indent pattern may cause localised wear of the mating surface after prolonged usage. This will result in the indent pattern becoming transferred

onto the mating surface in contact with the HI-EX bearing and may also give rise to fretting corrosion damage. In this situation DS™ material should be considered as an alternative to HI-EX.

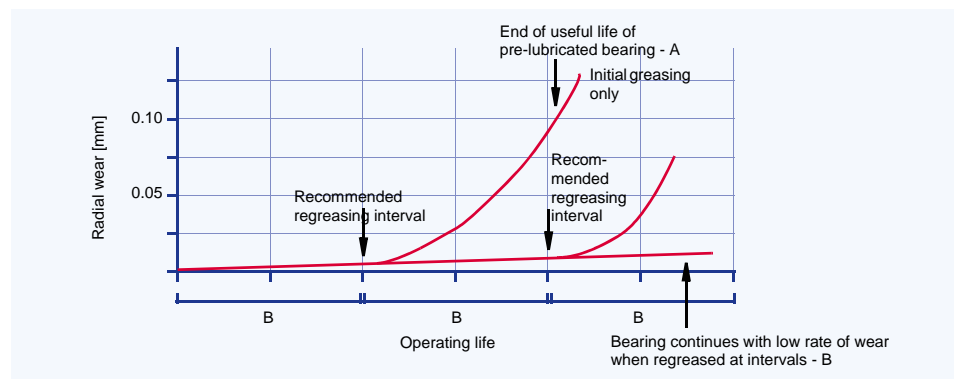

Fig. 8: Typical wear of HI-EX

5 Design Factors

The main parameters when determining the size or calculating the service life for a HI-EX bearing are:

- Specific Load Limit p_{lim} [MPa]
- pv Factor [MPa x m/s]
- Mating surface roughness R_a [μm]
- Mating surface material
- Temperature T [$^{\circ}\text{C}$]
- Other environmental factors eg. housing design, dirt, lubrication.

5.1 Specific Load

The specific load p is defined as the working load divided by the projected area of

the bearing and is expressed in MPa.

Bushes

$$(5.1.1) \quad p = \frac{F}{D_i \cdot B} \quad [\text{MPa}]$$

Slide Plates

$$(5.1.3) \quad p = \frac{F}{L \cdot W} \quad [\text{MPa}]$$

Thrust Washers

$$(5.1.2) \quad p = \frac{4F}{\pi \cdot (D_o^2 - D_i^2)} \quad [\text{MPa}]$$

Specific Load Limit

The maximum load which can be applied to a HI-EX bearing can be expressed in terms of the Specific Load Limit, which depends on the type of the loading and lubrication. It is highest under steady loads. Conditions of dynamic load or oscillating movement which produce fatigue stress in the bearing result in a reduction in the specific load limit. The values of Specific Load Limit specified in Table 5 assume good alignment between the bearing and mating surface.

The Specific Load Limit for HI-EX reduces for bearing operating temperatures in excess of 70 $^{\circ}\text{C}$, falling to about half the values given in Table 5 for temperatures above 150 $^{\circ}\text{C}$.

Conditions of dynamic load or oscillating movement which produce fatigue stress in the bearing result in a reduction in the permissible Specific Load Limit (Fig. 9, Page 14).

Load	Operating condition	Lubrication	p_{lim}
Steady	Intermittent or very slow (below 0.01 m/s) continuous rotation or oscillating motion	Grease or oil	140
Steady	Continuous rotation or oscillating motion	Grease or oil (boundary lubrication)	90
Steady or dynamic	Continuous rotation or oscillating motion	Oil (hydrodynamic lubrication)	60

Table 5: Specific load limit \bar{p}_{lim} for HI-EX

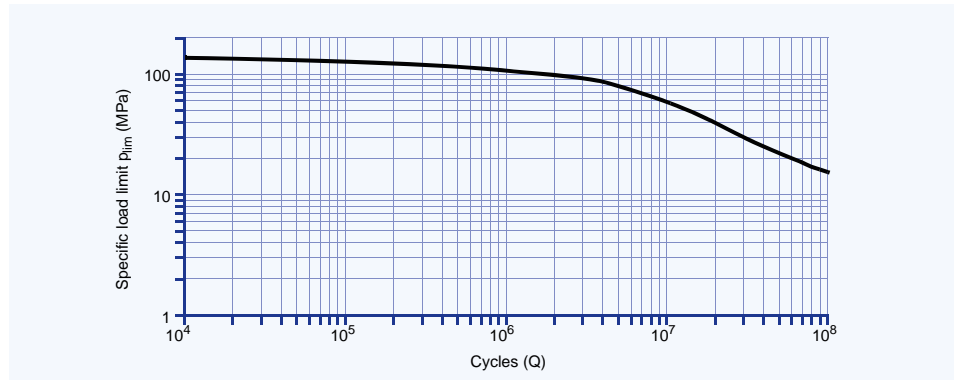

Fig. 9: HI-EX specific load limits p_{lim} under dynamic loads or oscillating conditions

5.2 Sliding Speed

The sliding speed v [m/s] is calculated as follows:

Continuous Rotation

Bushes

$$(5.2.1) \quad v = \frac{D_i \cdot \pi \cdot n}{60 \cdot 10^3} \quad [\text{m/s}]$$

Thrust Washers

$$(5.2.2) \quad v = \frac{D_o + D_i}{2} \cdot \pi \cdot n \quad [\text{m/s}]$$

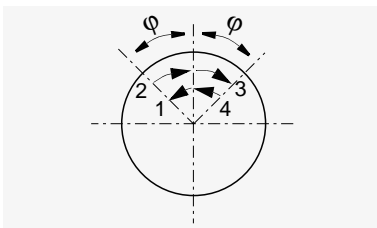

Fig. 10: Oscillating cycle φ

Oscillating Movement

Bushes

$$(5.2.3) \quad v = \frac{D_i \cdot \pi}{60 \cdot 10^3} \cdot \frac{4\varphi \cdot n_{osc}}{360} \quad [\text{m/s}]$$

Thrust Washers

$$(5.2.4) \quad U = \frac{D_o + D_i}{2} \cdot \pi \cdot \frac{4\varphi \cdot n_{osc}}{360} \quad [\text{m/s}]$$

The maximum permissible effective pv factor (epv factor) for grease lubricated HI-EX bearings is dependent upon the sliding

speed as shown in Fig. 11. For sliding speeds in excess of 2.5 m/s continuous oil lubrication is recommended.

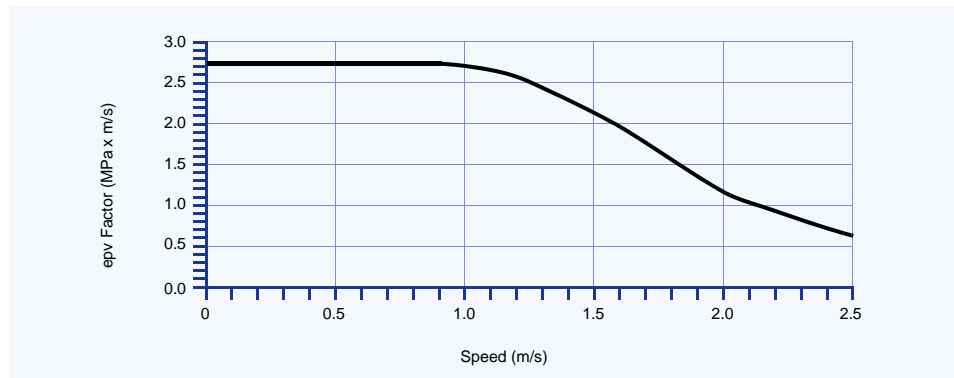

Fig. 11: Maximum epv factor for grease lubrication

5.3 pv Factor

The useful operating life of a HI-EX bearing is governed by the pv factor, which is calculated as follows:

$$(5.3.1) \quad [MPa \times m/s]$$

$$pv = p \cdot v$$

5.4 Load

In addition to its contribution to the pv factor the type and direction of the applied load also affects the performance of a HI-EX bearing. This is accommodated in the

calculation of the bearing service life by the speed/load application factor a_Q shown in Figs. 12-15.

Type of Load

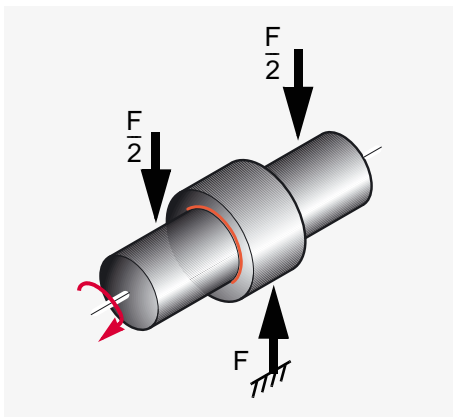

Fig. 12: Steady load, vertically downwards, bush stationary, shaft rotating. Lubricant drains to loaded area

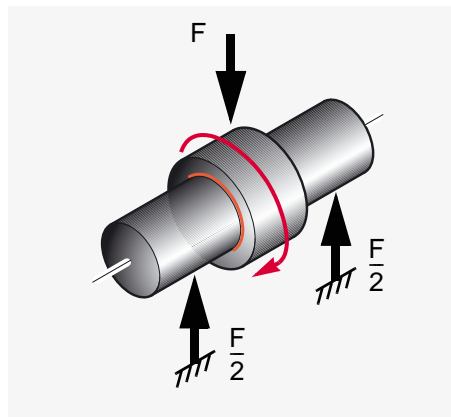

Fig. 14: Rotating load, shaft stationary, bush rotating

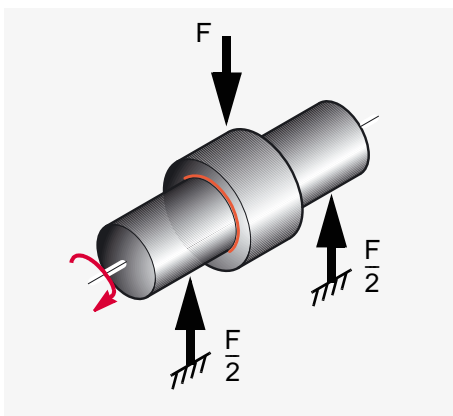

Fig. 13: Steady load, vertically upwards, bush stationary, shaft rotating. Lubricant drains away from loaded area

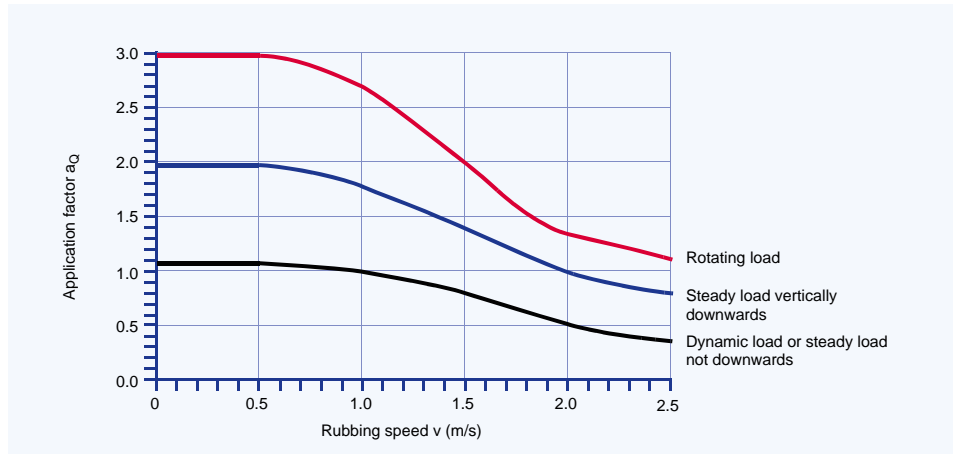

Fig. 15: Application factor a_Q for MB range bushes - unmachined

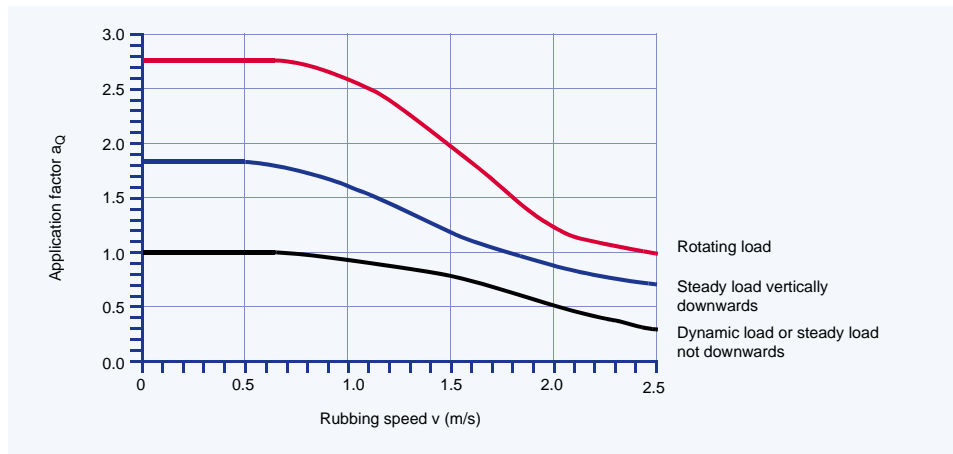

Fig. 16: Application factor a_Q for PM range and MB range bushes - machined

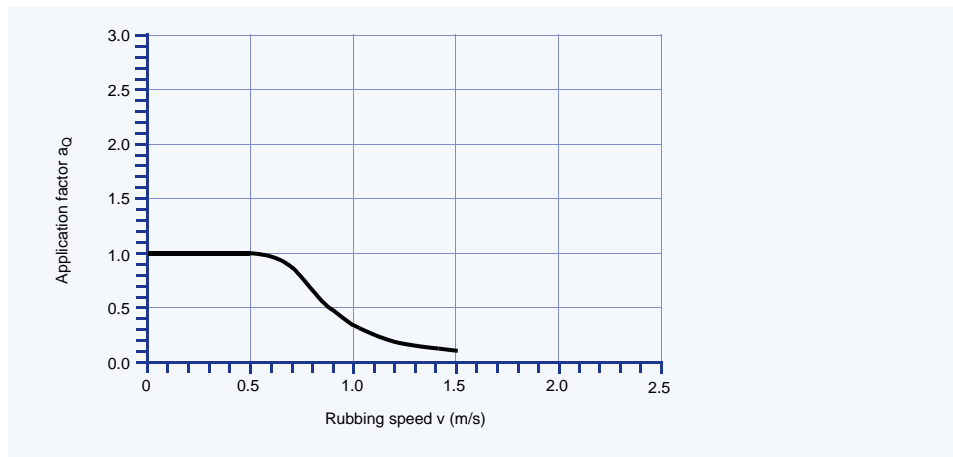

Fig. 17: Application factor a_Q for thrust washers

Note: $a_Q = 1$ for slideways

5.5 Temperature

The useful life of a HI-EX bearing depends upon the operating temperature. The performance of grease lubricated HI-EX decreases at bearing temperatures above 40 °C. This loss of performance is related to both material and lubricant effects.

For a given pv Factor the operating temperature of the bearing depends upon the

temperature of the surrounding environment and the heat dissipation properties of the housing.

In calculating the service life of HI-EX these effects are accommodated by the application factor a_T shown in Fig. 18

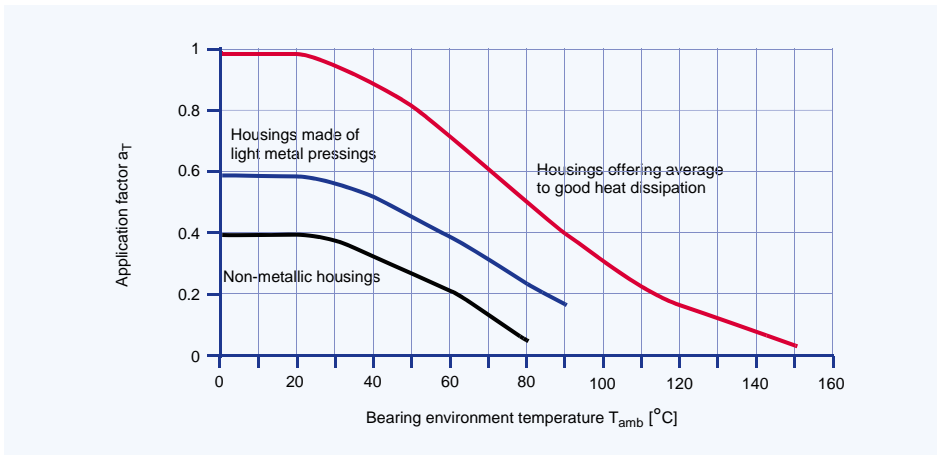

Fig. 18: HI-EX application factor a_T

5.6 Mating Surface

The wear rate of HI-EX is strongly dependent upon the roughness of the mating counterface. For optimum bearing performance the mating surface should be

ground to better than $0.4 \mu m R_a$. This effect is accommodated by the mating surface finish application factor a_S shown in Fig. 19.

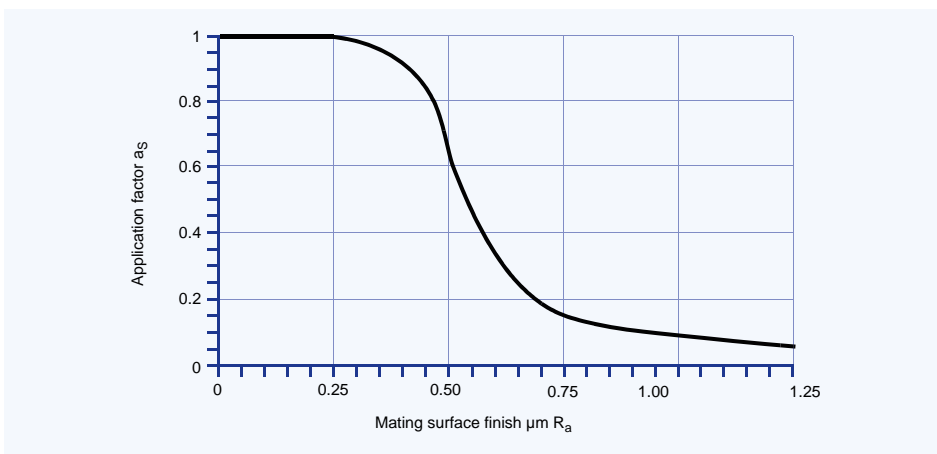

Fig. 19: HI-EX application factor a_S

5.7 Bearing Size

Frictional heat generated at the bearing surface and dissipated through the shaft and housing depends both on the operating conditions (i.e. pv factor) and the bearing size.

For a give pv condition a large bearing will run hotter than a smaller bearing. The bearing size factor a_B shown in Fig. 20 takes account of this effect.

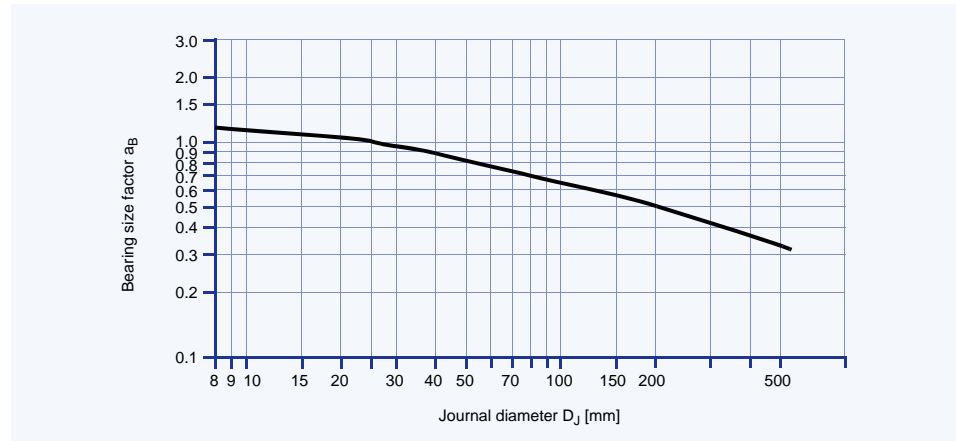

Fig. 20: Bearing size factor a_B

Note: $a_B = 1$ for slideways

5.8 Estimation of Bearing Service Life with Grease Lubrication

Calculation Parameters

Bushes		Thrust Washers		Slide Plates		Unit
Bearing diameter	D_i	Bearing outside diameter	D_o	Bearing Length	L	[mm]
Bearing width	B	Bearing inside diameter	D_i	Bearing Width	W	[mm]

Operating Conditions

Load	F	[N]
Rotational Speed (Continuous)	n	[1/min]
Oscillating Frequency	n_{osc}	[1/min]
Angular movement about mean position	φ	[°]
Specific Load Limit	see Table 5, Page 13	[MPa]
Application Factor a_Q	see Fig. 15-17, Page 16	[-]
Application Factor a_T	see Fig. 18, Page 17	[-]
Application Factor a_S	see Fig. 19, Page 17	[-]
Bearing Size Factor a_B	see Fig. 20, Page 18	[-]

Calculate p from the equations in 5.1 on Page 13.

Calculate v from the equations in 5.2 on Page 14.

Calculate pv from the equation in 5.3 on Page 15.

Calculate High Load Factor a_E

$$(5.8.1) \quad a_E = \frac{p_{lim}}{p_{lim} - p} \quad [-]$$

p_{lim} see Table 5, Page 13

Note:

If $a_E > 10000$, or $a_E < 0$, the bearing is overloaded.

Calculate Effective pv Factor epv

$$(5.8.2) \quad epv = \frac{a_E \cdot pv}{a_B} \quad [-]$$

Note:

Check that epv is less than limit set in Fig. 11 for the sliding speed U . If NOT, increase the bearing length or use continuous lubrication.

Estimate Bearing Life

If $epv < 1.0$ then

$$(5.8.3) \quad L_H = \frac{3000}{epv} \cdot a_Q \cdot a_T \cdot a_S \quad [h]$$

If $epv > 1.0$ then

$$(5.8.4) \quad L_H = \frac{3000}{(epv)^{2.4}} \cdot a_Q \cdot a_T \cdot a_S \quad [h]$$

Estimate Re-greasing Interval

$$(5.8.5) \quad L_{RG} = \frac{L_H}{2} \quad [h]$$

Oscillating Motion and Dynamic Loads

Oscillating Motion

Calculate number of cycles

$$(5.8.6) \quad Z_T = L_{RG} \cdot n_{osc} \cdot 60 \cdot (R + 2) \quad [-]$$

Dynamic Loads

Calculate number of cycles

$$(5.8.7) \quad C_T = L_{RG} \cdot C \cdot 60 \cdot (R + 2) \quad [-]$$

where R = Number of times bearing is regreased during total life required.

Check that Z_T (or C_T) is less than the total number of cycles Q given in Fig. 9 for actual bearing specific load p .

If Z_T (or C_T) $> Q$ then life will be limited by fatigue after Q cycles.

If Z_T (or C_T) $< Q$ then life will be limited by wear after Z_T cycles.

If the estimated life or total cycles are insufficient or the regreasing intervals are

too frequent, increase the bearing length or diameter, or consider drip feed or continuous oil lubrication, the quantity to be established by test.

5.9 Worked Examples

PM cylindrical Bush

Given:			
Load Details	Steady Load	Inside Diameter D_i	40 mm
	Direction: down	Width B	30 mm
Shaft	Steel, $R_a = 0.4 \mu\text{m}$	Bearing Load F	20000 N
	Temperature 85 °C	Rotational Speed n	30 1/min
Housing	Light metal - poor heat dissipation		

Calculation Constants and Application Factors			
Specific Load Limit p_{lim} at 85 °C	81.5 MPa	(Table 5, Page 13)	
Application Factor a_T	0.2	(Fig. 18, Page 17)	
Mating Surface Application Factor a_S	0.85	(Fig. 19, Page 17)	
Bearing Size Factor a_B for ϕ 40	0.95	(Fig. 20, Page 18)	
Application Factor for PM bush a_Q	1.8	(Fig. 16, Page 16)	

Calculation	Ref	Value
Specific Load p [MPa]	(5.1.1), Page 13	$p = \frac{F}{D_i \cdot B} = \frac{20000}{40 \cdot 30} = 16.67$
Sliding Speed v [m/s]	(5.2.1), Page 14	$v = \frac{D_i \cdot \pi \cdot n}{60 \cdot 10^3} = \frac{40 \cdot \pi \cdot 30}{60000} = 0.063$
High Load Factor a_E [-] (must be >0)	(5.8.1), Page 19	$a_E = \frac{p_{lim}}{p_{lim} - p} = \frac{81.5}{81.5 - 16.67} = 1.25$
epv Factor [-]	(5.8.2), Page 19	$epv = \frac{a_E \cdot p \cdot v}{a_B} = \frac{1.25 \cdot 16.67 \cdot 0.063}{0.95} = 1.382$
Life L_H [h] for $epv > 1$	(5.8.5), Page 19	$L_H = \frac{3000}{epv^{2.4}} \cdot a_Q \cdot a_T \cdot a_S = \frac{3000}{1.382^{2.4}} \cdot 1.8 \cdot 0.2 \cdot 0.85 = 434$
L_{RG} [h]	(5.8.5), Page 19	$L_{RG} = \frac{L_H}{2} = \frac{434}{2} = 217$

MB cylindrical bush

Given:			
Load Details	Steady Load, oscillating	Inside Diameter D_i	80 mm
	Direction: down	Width B	40 mm
Shaft	Steel, $R_a = 0.3 \mu\text{m}$	Bearing Load F	200000 N
	ambient Temperature	Frequency n_{osc}	1.11 1/min
Housing	Light metal - poor heat dissipation	Angle φ	20°

Calculation Constants and Application Factors			
Specific Load Limit p_{lim}	140 MPa	(Table 5, Page 13)	
Application Factor a_T	0.60	(Fig. 18, Page 17)	
Mating Surface Application Factor a_S	1.00	(Fig. 19, Page 17)	
Bearing Size Factor a_B for ϕ 80	0.75	(Fig. 20, Page 18)	
Application Factor for MB bush a_Q	1.80	(Fig. 16, Page 16)	

Calculation	Ref	Value
Specific Load p [MPa]	(5.1.1), Page 13	$p = \frac{F}{D_i \cdot B} = \frac{200000}{80 \cdot 40} = 62.50$
Sliding Speed v [m/s]	(5.2.3), Page 14	$v = \frac{D_i \cdot \pi \cdot 4\varphi \cdot n_{osc}}{60 \cdot 10^3 \cdot 360} = \frac{80 \cdot \pi \cdot 4 \cdot 20 \cdot 1.11}{60000 \cdot 360} = 0.001$
High Load Factor a_E [-] (must be >0)	(5.8.1), Page 19	$a_E = \frac{p_{lim}}{p_{lim} - p} = \frac{140}{140 - 62.50} = 1.806$
epv Factor [-]	(5.8.2), Page 19	$epv = \frac{a_E \cdot p \cdot v}{a_B} = \frac{1.806 \cdot 62.50 \cdot 0.001}{0.75} = 0.151$
Life L_H [h] for $epv < 1$	(5.8.5), Page 19	$L_H = \frac{3000}{epv} \cdot a_Q \cdot a_T \cdot a_S = \frac{3000}{0.151} \cdot 1.8 \cdot 0.6 \cdot 1.0 = 21456$
L_{RG} [h]	(5.8.5), Page 19	$L_{RG} = \frac{L_H}{2} = \frac{21456}{2} = 10728$
Z_T [-]	(5.8.5), Page 19	$Z_T = L_{RG} \cdot N_{osz} \cdot 60 \cdot (R+2) = 10728 \cdot 1.11 \cdot 60 \cdot 2 = 1.43 \cdot 10^6$ Q for $p = 62.50 = 1.43 \times 10^6$; $Z_T > Q$ Therefore bearing fails by fatigue after 1.43×10^6 cycles

PM cylindrical Bush

Given:			
Load Details	Steady Load	Inside Diameter D_i	100 mm
	Direction: up	Width B	60 mm
Shaft	Steel, $R_a = 0.3 \mu\text{m}$	Bearing Load F	45000 N
	Temperature 80 °C	Rotational Speed n	35 1/min
Housing	good heat dissipation		

Calculation Constants and Application Factors			
Specific Load Limit p_{lim} at 40 °C	90 MPa	(Table 5, Page 13)	
Application Factor a_T	0.50	(Fig. 18, Page 17)	
Mating Surface Application Factor a_S	1.00	(Fig. 19, Page 17)	
Bearing Size Factor a_B for ϕ 100	0.65	(Fig. 20, Page 18)	
Application Factor for PM bush a_Q	1.0	(Fig. 16, Page 16)	

Calculation	Ref	Value
Specific Load p [MPa]	(5.1.1), Page 13	$p = \frac{F}{D_i \cdot B} = \frac{45000}{100 \cdot 60} = 7.50$
Sliding Speed v [m/s]	(5.2.1), Page 14	$v = \frac{D_i \cdot \pi \cdot n}{60 \cdot 10^3} = \frac{100 \cdot \pi \cdot 35}{60000} = 0.183$
High Load Factor a_E [-] (must be >0)	(5.8.1), Page 19	$a_E = \frac{p_{lim}}{p_{lim} - p} = \frac{90}{90 - 7.50} = 1.091$
epv Factor [-]	(5.8.2), Page 19	$epv = \frac{a_E \cdot p \cdot v}{a_B} = \frac{1.091 \cdot 7.50 \cdot 0.183}{0.65} = 2.307$
Life L_H [h] for $epv > 1$	(5.8.5), Page 19	$L_H = \frac{3000}{(epv)^{2.4}} \cdot a_Q \cdot a_T \cdot a_S = \frac{3000}{2.307^{2.4}} \cdot 1.0 \cdot 1.0 \cdot 0.5 = 202$
L_{RG} [h]	(5.8.5), Page 19	$L_{RG} = \frac{L_H}{2} = \frac{202}{2} = 101$

Thrust washer

Given:			
Load Details	Steady Load	Inside Diameter D_i	40 mm
	Direction: down	Outside Diameter D_o	78 mm
Counterface	Steel, $R_a = 0.2 \mu\text{m}$	Bearing Load F	50000 N
	Temperature 50 °C	Rotational Speed n	25 1/min
Housing	Light metal - poor heat dissipation		

Calculation Constants and Application Factors			
Specific Load Limit p_{lim}	90 MPa	(Table 5, Page 13)	
Application Factor a_T for 50 °C	0.50	(Fig. 18, Page 17)	
Mating Surface Application Factor a_S	1.00	(Fig. 19, Page 17)	
Bearing Size Factor a_B for ϕ 40	0.95	(Fig. 20, Page 18)	
Application Factor for Thrust washers a_Q	1.00	(Fig. 17, Page 16)	

Calculation	Ref	Value
Specific Load p [MPa]	(5.1.1), Page 13	$p = \frac{4 \cdot F}{\pi \cdot (D_o^2 - D_i^2)} = \frac{4 \cdot 50000}{\pi \cdot (78^2 - 40^2)} = 14.20$
Sliding Speed v [m/s]	(5.2.2), Page 14	$v = \frac{D_o + D_i}{2} \cdot \pi \cdot n = \frac{78 + 40}{2} \cdot \pi \cdot 25 = \frac{2 \cdot 60 \cdot 10^3}{60 \cdot 10^3} = 0.0772$
High Load Factor a_E [-] (must be >0)	(5.8.1), Page 19	$a_E = \frac{p_{lim}}{p_{lim} - p} = \frac{90}{90 - 14.20} = 1.187$
epv Factor [-]	(5.8.2), Page 19	$epv = \frac{a_E \cdot p \cdot v}{a_B} = \frac{1.187 \cdot 14.20 \cdot 0.0772}{0.95} = 1.370$
Life L_H [h] for $epv > 1$	(5.8.5), Page 19	$L_H = \frac{3000}{(epv)^{2.4}} \cdot a_Q \cdot a_T \cdot a_S = \frac{3000}{1.370^{2.4}} \cdot 1.0 \cdot 0.5 \cdot 1.0 = 704$
L_{RG} [h]	(5.8.5), Page 19	$L_{RG} = \frac{L_H}{2} = \frac{704}{2} = 352$

6 Bearing Assembly

6.1 Dimensions and Tolerances

For optimum performance it is essential that the correct running clearance is used and that both the diameter of the shaft and the bore of the housing are finished to the limits given in the tables.

If the bearing housing is unusually flexible the bush will not close in by the calculated

amount and the running clearance will be more than the optimum. In these circumstances the housing should be bored slightly undersize or the journal diameter increased, the correct size being determined by experiment.

6.2 Tolerances for minimum clearance

Grease lubrication

The minimum clearance required for satisfactory performance of HI-EX depends upon the pv factor, the sliding speed and the environmental temperature, any one or combination of which may reduce the diametral clearance in operation due to inward thermal expansion of the HI-EX polymer lining. It is therefore necessary to compensate for this.

Fig. 21 shows the minimum diametral clearance plotted stepped against journal diameter at an ambient 20 °C. Where the stepped lines show a change of clearance for a given journal diameter, the lower value is used.

The superimposed straight lines indicate the minimum permissible diametral clear-

ance for various values of pvu (Fig. 21), where pv is calculated as in 5.3 on Page 15, and u is a sliding speed factor for speeds in excess of 0.5 m/s given in Fig. 22.

If the clearance indicated for a pvu factor lies below the stepped lines the recommended standard shaft may be used. If above, the shaft size must be reduced to obtain the clearance indicated on the vertical axis of the relevant figure.

Under slow speed and high load conditions it may be possible to achieve satisfactory performance with diametral clearances less than those indicated. But adequate prototype testing is recommended in such cases.

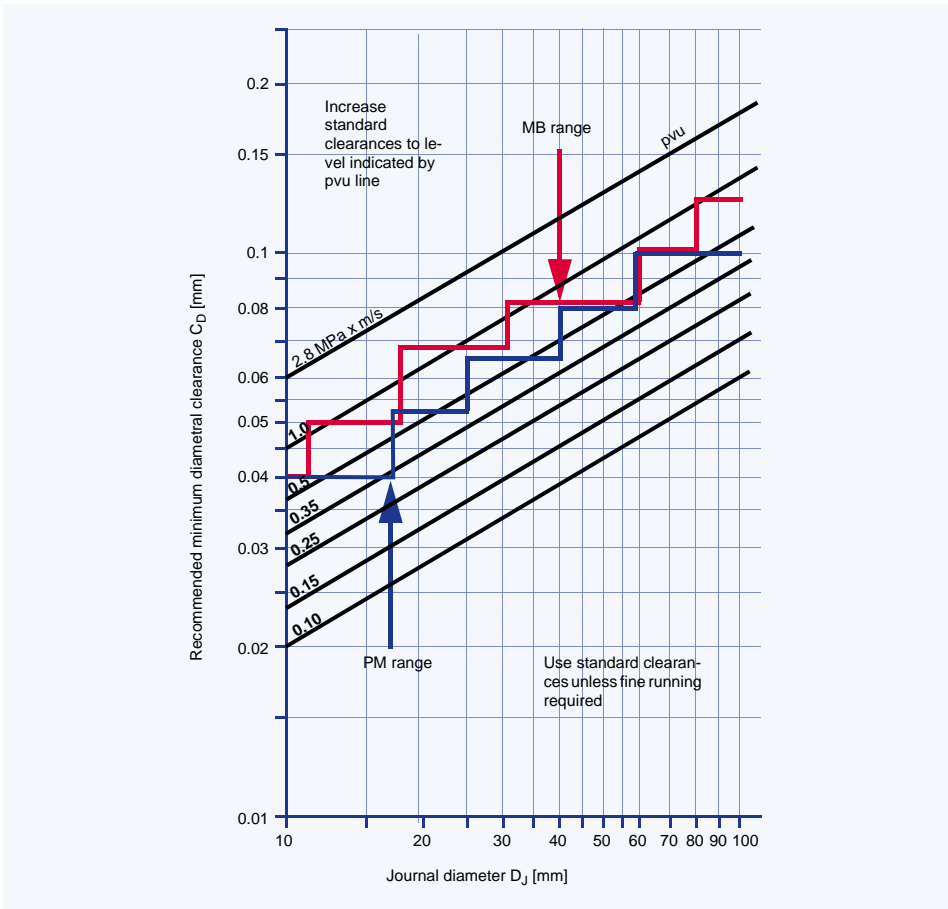

Fig. 21: Minimum clearance for PM prefinished and MB machinable range machined to H7 bore

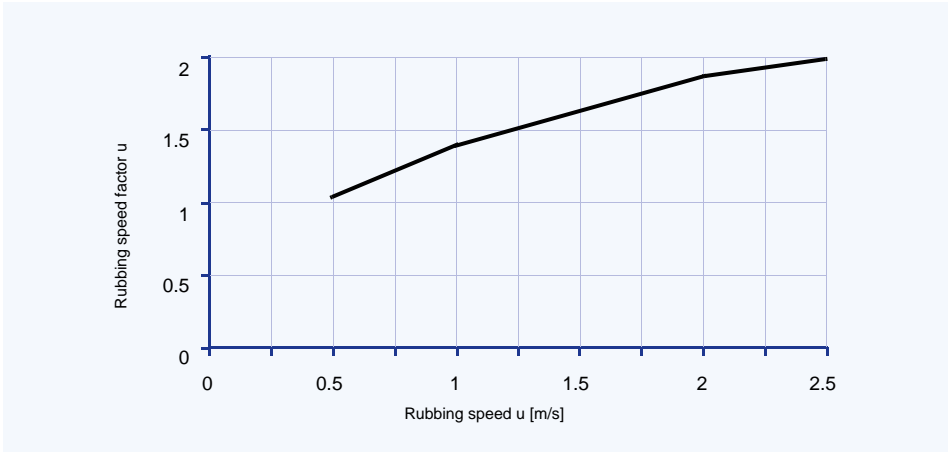

Fig. 22: Rubbing speed factor u

Fluid Lubrication

The minimum clearance required for journal bearings operating under hydrodynamic or mixed film conditions for a range of shaft rotational speeds and diameters is

shown in Fig. 23. It is recommended that the bearing performance under minimum clearance conditions be confirmed by testing if possible.

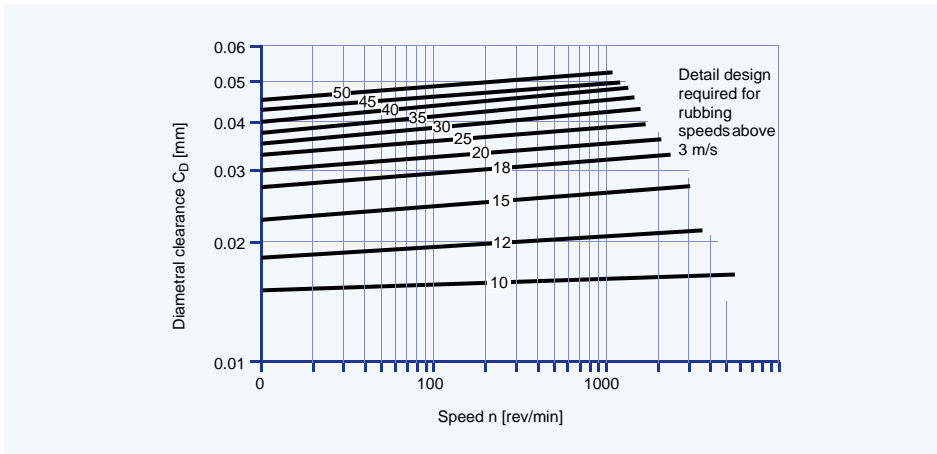

Fig. 23: HI-EX minimum clearances - bush diameters D_i 10-50 mm

Allowance for Thermal Expansion

For operation in high temperature environments the clearance should be increased by the amounts indicated by Fig. 24 to

compensate for the inward thermal expansion of the bearing lining.

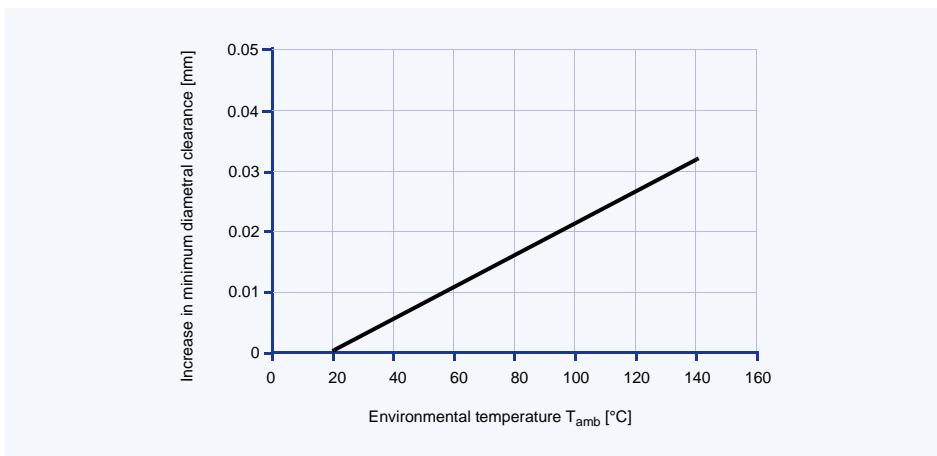

Fig. 24: Recommended increase in diametral clearance

If the housing is non-ferrous then the bore should be reduced by the amounts given in Table 5, in order to give an increased inter-

ference fit to the bush, with a similar reduction in the journal diameter additional to that indicated by Fig. 24.

Housing material	Reduction in housing diameter per 100 °C rise	Reduction in shaft diameter per 100 °C rise
Aluminium alloys	0.1%	0.1% + values from Fig. 24
Copper base alloys	0.05%	0.05% + values from Fig. 24
Steel and cast iron	Nil	values from Fig. 24
Zinc base alloys	0.15%	0.15% + values from Fig. 24

Table 6: Allowance for high temperature

6.3 Counterface Design

HI-EX bearings may be used with all conventional mating surface materials. Hardening of steel journals is not required unless abrasive dirt is present or if the projected bearing life is in excess of 2000 hours, in which cases a minimum shaft hardness of 350HB is recommended.

A ground surface finish of better than $0.4 \mu\text{m } R_a$ is recommended. The final direction of machining of the mating surface should preferably be the same as the direction of motion relative to the bearing in service.

HI-EX is normally used in conjunction with ferrous journals and thrust faces, but in damp or corrosive surroundings stainless steel, hard chromium plated mild steel, or

alternatively WH shaft sleeves are recommended. When plated mating surfaces are specified the plating should possess adequate strength and adhesion, particularly if the bearing is to operate with high fluctuating loads.

The shaft or thrust collar used in conjunction with the HI-EX bush or thrust washer must extend beyond the bearing surface in order to avoid cutting into it. The mating surface must also be free from grooves or flats, the end of the shaft should be given a lead-in chamfer and all sharp edges or projections which may damage the soft polymer lining of the HI-EX must be removed.

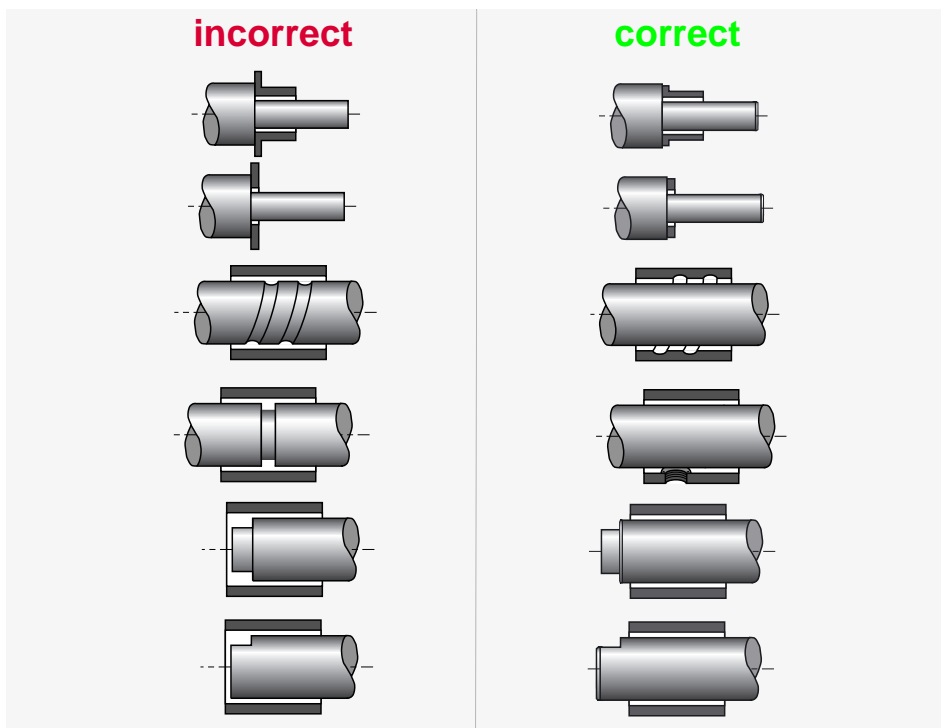

Fig. 25: Counterface design

6.4 Installation

Important Note

Care must be taken to ensure that the HI-EX lining material is not damaged during the installation.

Fitting of Bushes

The bush is inserted into its housing with the aid of a stepped mandrel, preferably made from case hardened mild steel, as shown in Fig. 26. The following should be noted to avoid damage to the bearing:

- Housing diameter is as recommended
- 15-20 deg lead-in chamfer on housing
- The bush must be square to the housing
- Light smear of oil on bush OD

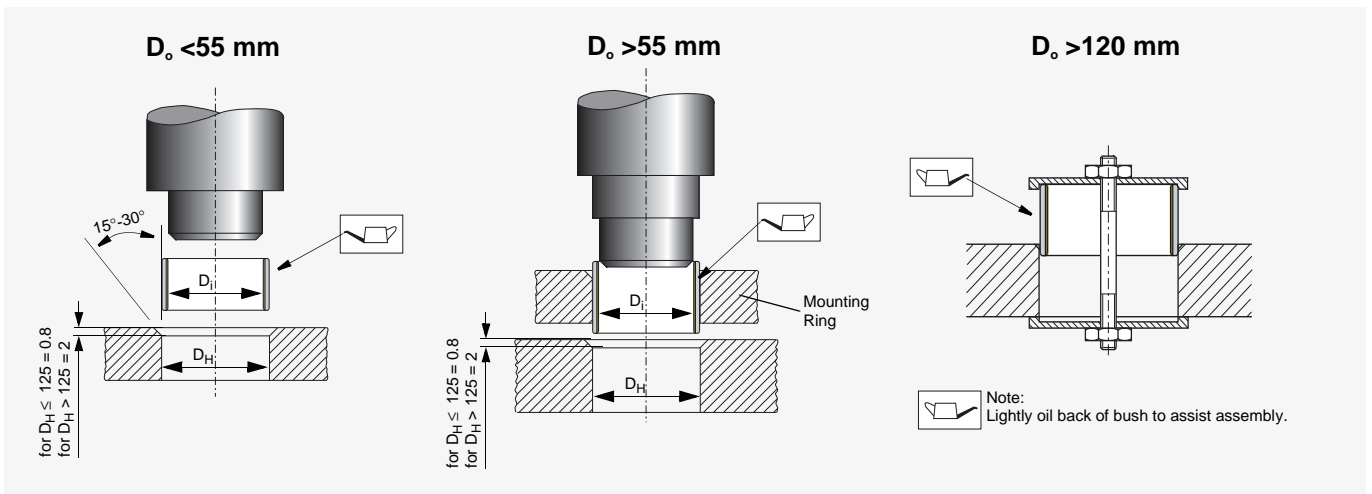

Fig. 26: Fitting of bushes

Insertion Forces

Fig. 27 gives an indication of the maximum insertion force required to correctly install standard HI-EX bushes.

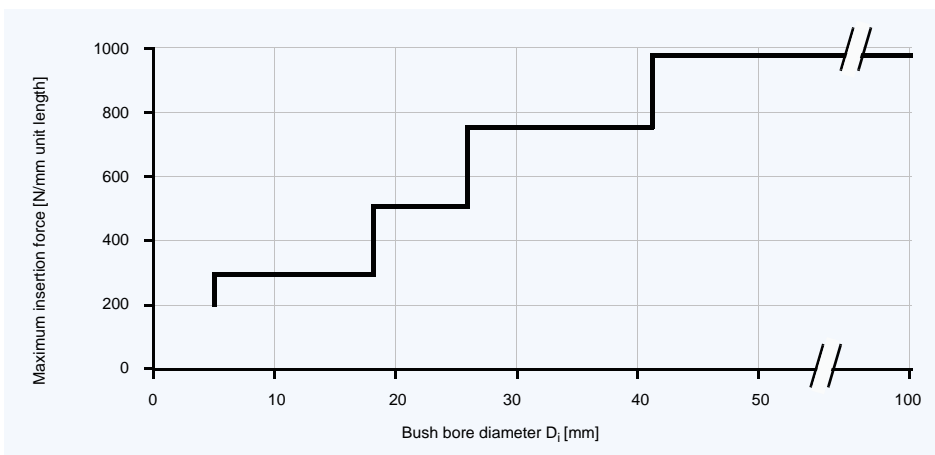

Fig. 27: Maximum insertion force F_i

Alignment

Accurate alignment is an important consideration for all bearing assemblies. With HI-EX bearings misalignment over the length

of a bush (or pair of bushes), or over the diameter of a thrust washer should not exceed 0.020 mm as illustrated in Fig. 28.

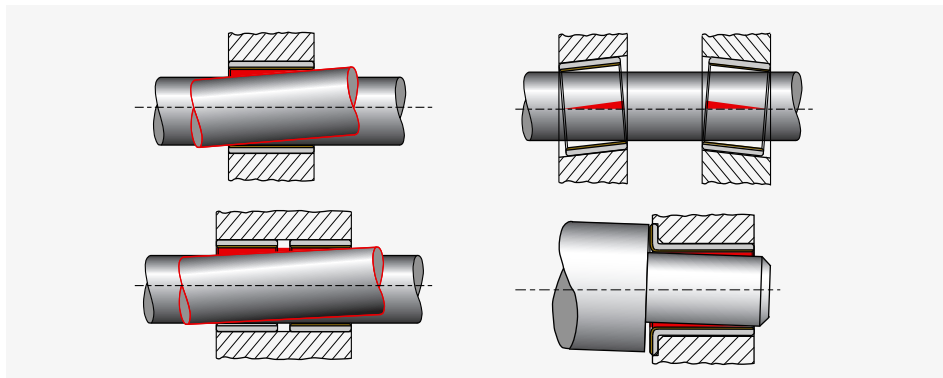

Fig. 28: Alignment

Sealing

While HI-EX can tolerate the ingress of some contaminant materials into the bearing without loss of performance, where there is the possibility of highly abrasive

material entering the bearing, a suitable sealing arrangement, as illustrated in Fig. 29 should be provided.

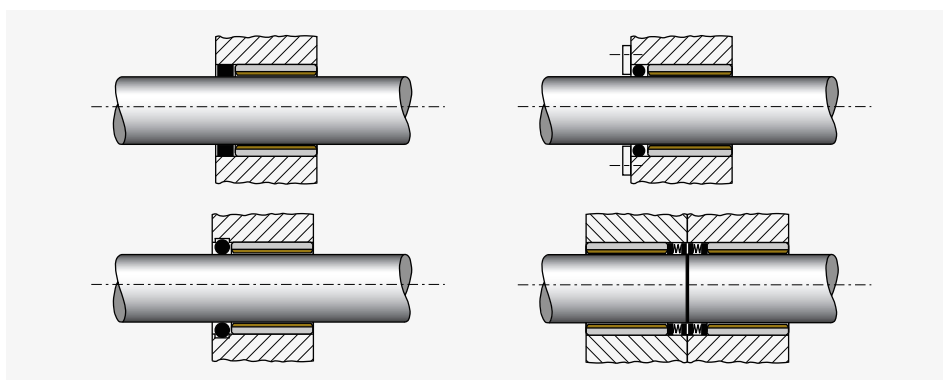

Fig. 29: Recommended sealing arrangements

Axial Location

Where axial location is necessary, it is generally advisable to fit HI-EX thrust washers in conjunction with HI-EX bushes, even when the axial loads are low. Experience

has shown that fretting debris from unsatisfactory locating surfaces can enter an adjacent HI-EX bush and adversely affect the bearing life and performance.

Fitting of Thrust Washers

HI-EX thrust washers should be located on the outside diameter in a recess as shown in Fig. 30. The inside diameter must be clear of the shaft in order to prevent contact with the steel backing of the HI-EX material. The recess diameter should be 0.125 mm larger than the washer diameter and the depth as given in the product tables.

If there is no recess for the thrust washer one of the following methods of fixing may be used:

- two dowel pins
- two screws
- adhesive

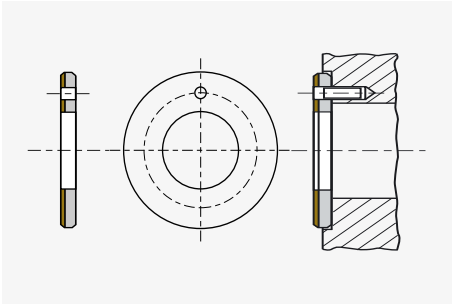

Fig. 30: Installation of Thrust-Washer

Important Note

- Dowel pins should be recessed 0.25 mm below the bearing surface
- Screws should be countersunk 0.25 mm below the bearing surface
- HI-EX must not be heated above 250 °C
- Contact adhesive manufacturers for guidance on the selection of suitable adhesives
- Protect the bearing surface to prevent contact with adhesive
- Ensure the washer ID does not touch the shaft after assembly
- Ensure that the washer is mounted with the steel backing to the housing

Slideways

HI-EX strip material for use as slideway bearings should be installed using one of the following methods:

- countersunk screws
- adhesives
- mechanical location

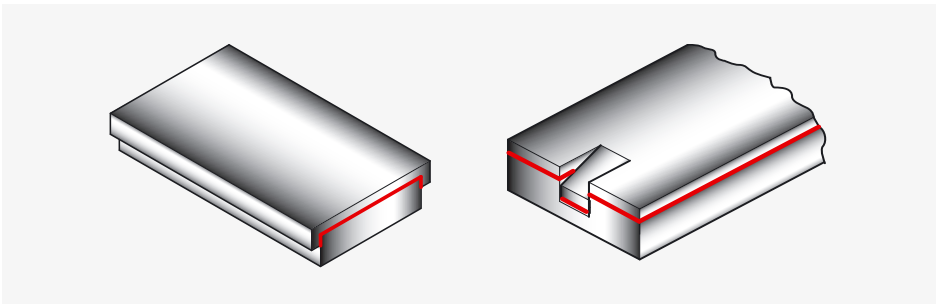

Fig. 31: Mechanical location of HI-EX slideways

7 Machining

7.1 Machining Practice

The PEEK polymer lining of HI-EX has good machining characteristics and can be treated as a free cutting brass in most respects. The indents in the bearing surface may lead to the formation of burrs or whiskers due to the resilience of the lining material, but this can be avoided by using machining methods which remove the lining as a ribbon, rather than a narrow thread.

When machining HI-EX it is recommended that not more than 0.125 mm is removed-

from the lining thickness in order to ensure that the lubricant capacity of the indents remaining after machining is not significantly reduced.

Boring, reaming and broaching are all suitable machining methods for use with HI-EX. The recommended tool material is high speed steel or tungsten carbide, respectively diamonds for long tool service times.

7.2 Boring

Fig. 32 illustrates a recommended boring tool which should be mounted with its axis at right angles to the direction of feed.

The essential characteristic required in the boring tool is a tip radius greater than 1.5 mm, which combined with a side rake of 30° will produce the ribbon effect required.

Cutting speeds should be high, the optimum between 2.0 and 4.5 m/s. The feed should be low, in the range 0.05/0.025 mm for cuts of 0.125 mm, the lower feeds being used with the higher cutting speeds.

Satisfactory finishes can usually be obtained machining dry and an air blast may facilitate swarf removal. The use of coolant is not detrimental.

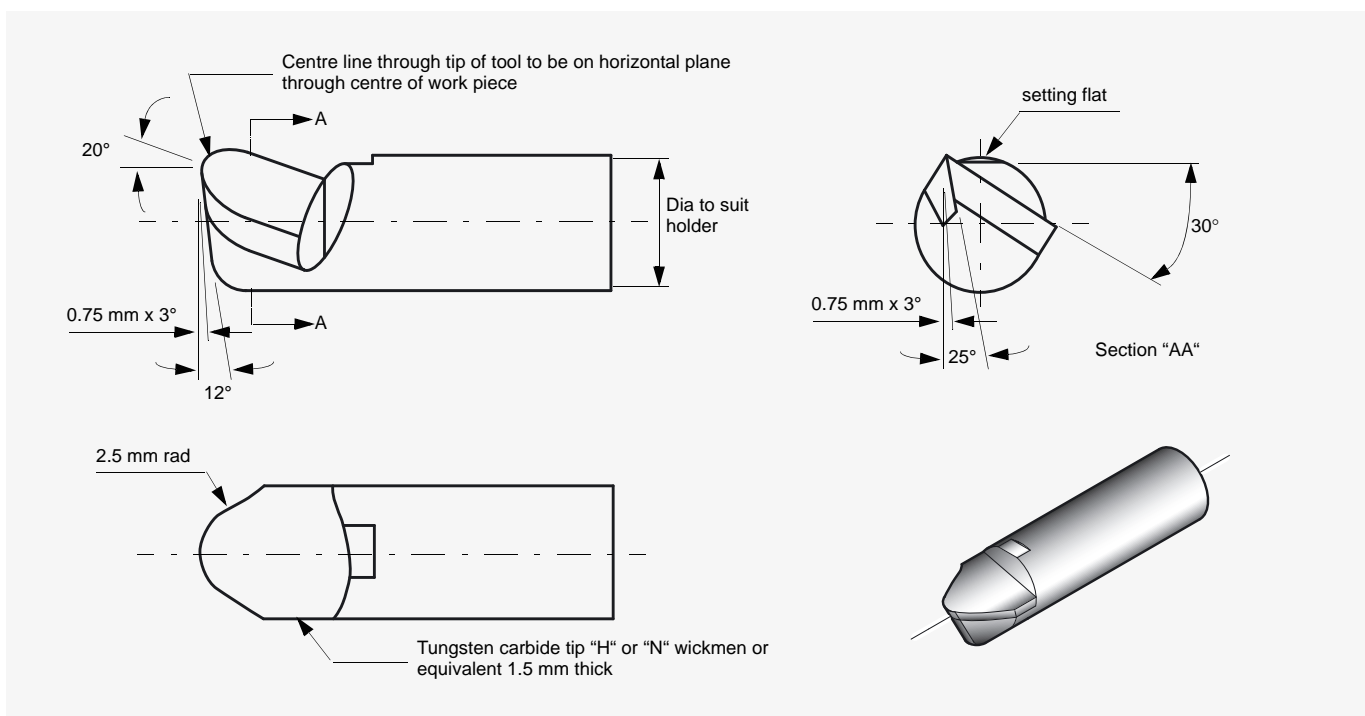

Fig. 32: Boring tool for HI-EX

7.3 Reaming

HI-EX can be reamed satisfactorily by hand with a straight-fluted expanding reamer. For best results the reamer should be sharp, the cut 0.025-0.050 mm and the

feed slow. Where hand reaming is not desired machining speeds of about 0.05 m/s are recommended with the cuts and feeds as for boring.

7.4 Broaching

Fig. 33 shows broaches suitable for finishing bushes up to 65 mm diameter. The

broach should be used dry, at a speed of 0.1-0.5 m/s.

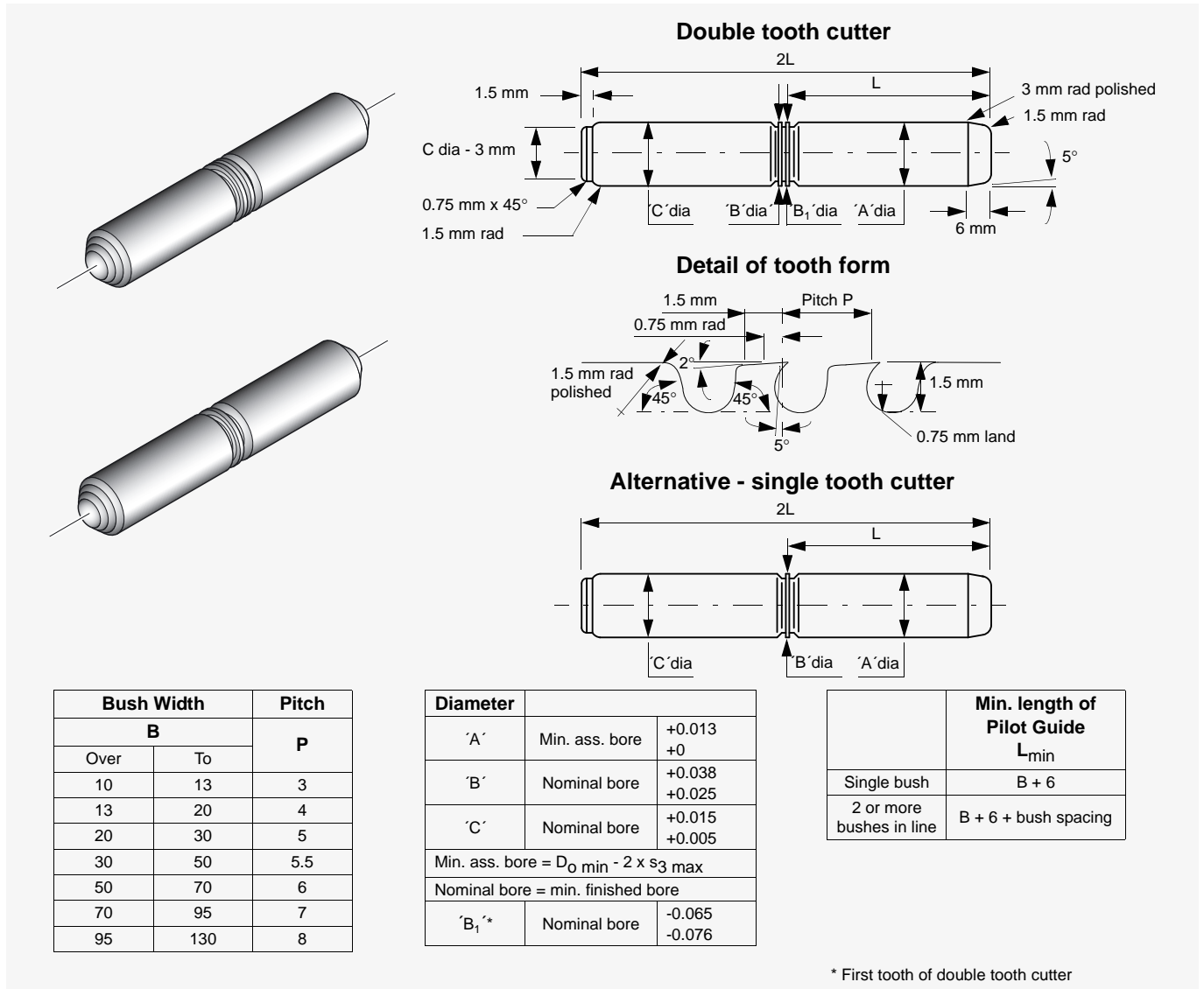

Fig. 33: Suitable broaches for HI-EX

Use the single tooth version where the bush is less than 25 mm long, and the double tooth broach for longer bushes or for two or more bushes together.

If it is necessary to make up a special form of broach the following points should be noted:

- Adequate provision should be made for locating the bush by providing a pilot to suit the bore of the bush when pressed home. A rear support shoulder should locate in the broached bore of the bush after cutting. Alternatively, special guides may be provided external to the workpiece.

- If two bushes are to be broached in line, then the pilot guide and rear support should be longer than the distance between the two bushes.
- For large bushes it may be necessary to provide axial relief along the length of the pilot guide and rear support, in order to reduce the broaching forces.
- Unless a guided broach is used, the tool will follow the initial bore alignment of the bush, broaching cannot improve concentricity and parallelism unless external guides are used.

In general owing to the variation in wall thickness of large diameter bushes, broaching is not suitable for finishing bores of more than 60 mm diameter unless external guides are used.

7.5 Vibrobroaching

This technique may also be used. A single cutter is propelled with progressive reciprocating motion with a vibration frequency of typically 50 Hz. The cutter should have a primary rake of 1.5° for 0.5 mm. A cut of

0.25 mm on diameter may be made at an average cutting speed of 0.15 m/s to give a surface finish of better than $0.8 \mu\text{m } R_a$, which is acceptable.

7.6 Modification of components

The modification of HI-EX bearing components requires no special procedures. In general it is more satisfactory to perform machining or drilling operations from the polymer lining side in order to avoid burrs. When cutting is done from the steel side,

the minimum cutting pressure should be used and care taken to ensure that any steel or bronze particles protruding into the remaining bearing material, and all burrs, are removed.

7.7 Drilling Oil Holes

Bushes should be adequately supported during the drilling operation to ensure that

no distortion is caused by the drilling pressure.

7.8 Cutting Strip Material

HI-EX strip material may be cut to size by any one of the following methods. Care must be taken to protect the bearing surface from damage and to ensure that no deformation of the strip occurs.

- Using side and face cutter, or slitting saw, with the strip held flat and securely on a horizontal milling machine.
- Cropping
- Guillotine
(For widths less than 90 mm only)
- Water-jet cutting, Laser cutting

8 Electroplating

HI-EX Components

To provide corrosion protection the mild steel backing of HI-EX may be electroplated with most of the conventional electroplating metals including the following:

- zinc ISO 2081-2
- nickel ISO 1456-8
- hard chromium ISO 1456-8

For the harder materials if the specified plating thickness exceeds approximately

5 μm then the housing diameter should be increased by twice the plating thickness in order to maintain the correct assembled bearing bore size.

Where electrolytic attack is possible tests should be conducted to ensure that all the materials in the bearing environment are mutually compatible.

Mating Surfaces

HI-EX can be used against hard chrome plated materials and care should be taken to ensure that the recommended shaft

sizes and surface finish are achieved after the plating process.

Note:

The parts shown in the following tables are not available from stock.

9 Standard Products

9.1 PM-HI-EX cylindrical bushes

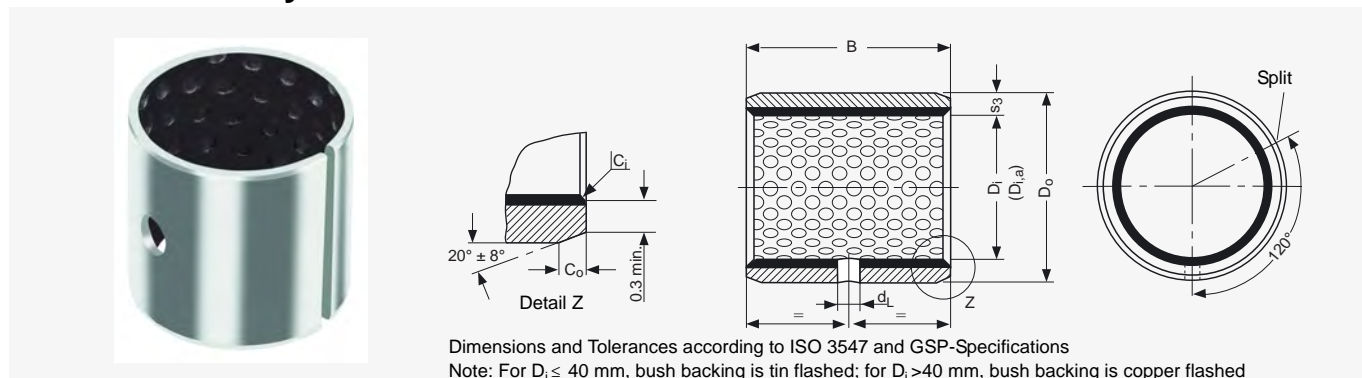

All dimensions in mm

Outside C_o and Inside C_i chamfers

Wall thickness s_3	C_o (a)		C_i (b)
	machined	rolled	
1	0.6 ± 0.4	0.6 ± 0.4	-0.1 to -0.5
1.5	0.6 ± 0.4	0.6 ± 0.4	-0.1 to -0.7

Wall thickness s_3	C_o (a)		C_i (b)
	machined	rolled	
2	1.2 ± 0.4	1.0 ± 0.4	-0.1 to -0.7
2.5	1.8 ± 0.6	1.2 ± 0.4	-0.2 to -1.0

a = Chamfer C_o machined or rolled at the option of the manufacturer

b = C_i can be a radius or a chamfer in accordance with ISO 13715

Part No.	Nominal Diameter		Wall thickness s_3	Width B	Shaft- \varnothing D_J [h8]		Housing- \varnothing D_H [H7]		Bush- \varnothing $D_{i,a}$ Ass. in H7 housing	Clearance C_D	Oil hole- \varnothing d_L							
	D_i	D_o			max. min.	max. min.	max. min.	max. min.				max. min.						
PM0808HX	8	10	0.980 0.955	8.25	h8	8.000	10.015	8.105	0.127 0.040	No hole								
PM0810HX				7.75							7.978	8.040						
PM0812HX				10.25							10.000	10.108						
PM1010HX	10	12		11.75		10.000	9.978	12.018		10.108	0.130 0.040							
PM1012HX				12.25								12.000	10.040					
PM1015HX				11.75								12.000	10.040					
PM1020HX				14.75								14.000	12.040					
PM1210HX				12								14	20.25	h8	11.973	14.018	12.108	0.135 0.040
PM1212HX													19.75					
PM1215HX	25.25	14.000				12.040												
PM1220HX	24.75	14.000				12.040												
PM1225HX	15.25	14.000				12.040												
PM1415HX	14	16		14.75		h8	14.000	16.018		14.108	0.135 0.040							
PM1420HX				19.75								14.000	14.040					
PM1425HX				24.75								14.000	14.040					
PM1508HX	15	17	8.25	h8	15.000	17.018	15.108	0.135 0.040										
PM1510HX			7.75						14.973	15.040								
PM1510HX			10.25						14.973	15.040								

Part No.	Nominal Diameter		Wall thickness s_3	Width B	Shaft- \varnothing D_j [h8]	Housing- \varnothing D_H [H7]	Bush- \varnothing $D_{i,a}$ Ass. in H7 housing	Clearance C_D	Oil hole- \varnothing d_L	
	D_i	D_o								max. min.
PM1512HX	15	17	0.980 0.955	12.25	15.000	17.018	15.108	0.135 0.040	4	
PM1515HX				11.75						
PM1520HX				15.25						
PM1525HX				14.75						
PM1615HX	16	18		20.25	16.000	18.018	16.108			
PM1620HX				19.75						
PM1625HX				25.25						
PM1815HX	18	20		24.75	18.000	20.021	18.111			
PM1820HX				15.25						
PM1825HX				14.75						
PM2010HX				20.25						
PM2015HX	20	23		19.75	20.000	23.021	20.131			
PM2020HX			9.75							
PM2025HX			14.75							
PM2030HX			20.25							
PM2215HX	22	25	19.75	22.000	25.021	22.131				
PM2220HX			14.75							
PM2225HX			20.25							
PM2230HX			19.75							
PM2415HX	24	27	24.75	24.000	27.021	24.131				
PM2420HX			15.25							
PM2425HX			14.75							
PM2430HX			20.25							
PM2515HX	25	28	29.75	25.000	28.021	25.131				
PM2520HX			15.25							
PM2525HX			14.75							
PM2530HX			20.25							
PM283130HX	28	31	30.25	28.000	31.025	28.135	0.168 0.050			
PM2820HX		29.75	28.000		32.025	28.050				
PM2825HX		32						20.25		28.155
PM2830HX		19.75						24.75		
PM3020HX	30	34		24.75			30.000	34.025		
PM3025HX			30.25	29.967	30.060					
PM3030HX			29.75							
PM3040HX			40.25							
			39.75							

9 Standard Products

Part No.	Nominal Diameter		Wall thickness s_3 max. min.	Width B max. min.	Shaft- \varnothing D_J [h8] max. min.	Housing- \varnothing D_H [H7] max. min.	Bush- \varnothing $D_{L,a}$ Ass. in H7 housing max. min.	Clearance C_D max. min.	Oil hole- \varnothing d_L
	D_i	D_o							
PM3220HX	32	36	1.970 1.935	20.25	32.000 31.961	36.025 36.000	32.155 32.060	0.194 0.060	6
PM3230HX				19.75					
PM3235HX				30.25					
PM3240HX				29.75					
PM3520HX	35	39		35.25	35.000 34.961	39.025 39.000	35.155 35.060		
PM3530HX				34.75					
PM3535HX				40.25					
PM3540HX				39.75					
PM3550HX	36	40		50.25	36.000 35.961	40.025 40.000	36.155 36.060		
PM3635HX				49.75					
PM3720HX				35.25					
PM3720HX				34.75					
PM4020HX	37	41	20.25	37.000 36.961	41.025 41.000	37.155 37.060			
PM4020HX			19.75						
PM4030HX			30.25						
PM4030HX			29.75						
PM4040HX	40	44	40.25	40.000 39.961	44.025 44.000	40.155 40.060			
PM4040HX			39.75						
PM4050HX			50.25						
PM4050HX			49.75						
PM4520HX	45	50	20.25	45.000 44.961	50.025 50.000	45.195 45.080			
PM4520HX			19.75						
PM4525HX			25.25						
PM4525HX			24.75						
PM4530HX	45	50	30.25	45.000 44.961	50.025 50.000	45.195 45.080			
PM4530HX			29.75						
PM4540HX			40.25						
PM4540HX			39.75						
PM4545HX	45	50	45.25	45.000 44.961	55.030 55.000	50.200 50.080			
PM4545HX			44.75						
PM4550HX			50.25						
PM4550HX			49.75						
PM5030HX	50	55	20.25	50.000 49.961	55.030 55.000	50.200 50.080			
PM5030HX			19.75						
PM5040HX			40.25						
PM5040HX			39.75						
PM5045HX	50	55	45.25	50.000 49.961	55.030 55.000	50.200 50.080			
PM5045HX			44.75						
PM5050HX			50.25						
PM5050HX			49.75						
PM5060HX	50	55	60.25	50.000 49.961	55.030 55.000	50.200 50.080			
PM5060HX			59.75						
PM5520HX			20.25						
PM5520HX			19.75						
PM5525HX	55	60	25.25	55.000 54.954	60.030 60.000	55.200 55.080			
PM5525HX			24.75						
PM5530HX			30.25						
PM5530HX			29.75						
PM5540HX	55	60	40.25	55.000 54.954	60.030 60.000	55.200 55.080			
PM5540HX			39.75						
PM5550HX			50.25						
PM5550HX			49.75						
PM5560HX	55	60	60.25	55.000 54.954	60.030 60.000	55.200 55.080			
PM5560HX			59.75						

Part No.	Nominal Diameter		Wall thickness s_3	Width B	Shaft- \varnothing D_j [h8]	Housing- \varnothing D_H [H7]	Bush- \varnothing $D_{i,a}$ Ass. in H7 housing	Clearance C_D	Oil hole- \varnothing d_L
	D_i	D_o							
PM6030HX	60	65	2.460 2.415	30.25	60.000 59.954	65.030 65.000	60.200 60.080	0.246 0.080	8
PM6040HX				29.75					
PM6050HX				40.25					
PM6060HX				39.75					
PM6070HX				50.25					
PM6530HX	65	70	2.450 2.384	49.75	65.000 64.954	70.030 70.000	65.262 65.100	0.308 0.100	
PM6540HX				60.25					
PM6550HX				59.75					
PM6560HX				70.25					
PM6570HX				69.75					
PM7030HX	70	75	2.450 2.384	30.25	70.000 69.954	75.030 75.000	70.262 70.100	0.313 0.100	
PM7040HX				29.75					
PM7045HX				40.25					
PM7050HX				39.75					
PM7060HX				45.25					
PM7065HX	44.75								
PM7070HX	75	80	2.450 2.384	50.25	75.000 74.954	80.030 80.000	80.267 80.100	0.321 0.100	
PM7080HX				49.75					
PM7540HX				60.25					
PM7560HX				59.75					
PM7580HX				80.25					
PM8040HX	80	85	2.450 2.384	79.75	80.000 79.954	85.035 85.000	85.267 85.100	0.321 0.100	
PM8050HX				40.25					
PM8060HX				39.75					
PM8080HX				60.25					
PM80100HX				59.75					
PM8530HX	85	90	2.450 2.384	80.50	85.000 84.946	90.035 90.000	85.267 85.100	0.321 0.100	
PM8540HX				79.50					
PM8560HX				100.50					
PM8580HX				99.50					
PM85100HX				30.50					

9 Standard Products

Part No.	Nominal Diameter		Wall thickness s_3	Width B	Shaft- \varnothing D_J [h8]		Housing- \varnothing D_H [H7]		Bush- \varnothing $D_{L,a}$ Ass. in H7 housing		Clearance C_D	Oil hole- \varnothing d_L				
	D_i	D_o			max. min.	max. min.	max. min.	max. min.	max. min.	max. min.						
PM9040HX	90	95	2.450 2.384	40.50	90.000 89.946	95.035 95.000	90.267 90.100	0.321 0.100	9.5							
PM9060HX				39.50												
PM9080HX				60.50												
PM9090HX				59.50												
PM90100HX				80.50												
PM9560HX	79.50															
PM95100HX	90.50															
PM10040HX	89.50															
PM10050HX	100.50															
PM10060HX	99.50															
PM10080HX	60.50															
PM10095HX	59.50															
PM100115HX	100.50															
PM10560HX	99.50															
PM10565HX	40.50	105		110						60.50	105.000 104.946	110.035 110.000	105.267 105.100	0.321 0.100	9.5	
PM105110HX	59.50															
PM105115HX	50.50															
PM11050HX	49.50															
PM11060HX	60.50															
PM110100HX	59.50	110	115	100.50	110.000 109.946	115.035 115.000	110.267 105.100	0.321 0.100	9.5							
PM110110HX	99.50															
PM110115HX	110.50															
PM11550HX	109.50															
PM11570HX	115.50															
PM12060HX	114.50	115	120	50.50	115.000 114.946	120.035 120.000	115.267 115.100	0.321 0.100	9.5							
PM120100HX	49.50															
PM120110HX	60.50															
PM12560HX	59.50															
PM125100HX	100.50			125						130	99.50	125.000 124.937	130.040 130.000	125.280 125.130	0.334 0.130	9.5
PM125110HX	110.50															
PM13050HX	109.50															
PM13060HX	60.50	130	135		49.50	130.000 129.937	135.040 135.000	130.280 130.130	0.343 0.130		No hole					
PM13080HX	60.50															
PM130100HX	59.50															
	80.50															
	79.50															
	100.50			99.50												

Part No.	Nominal Diameter		Wall thickness s_3	Width B	Shaft- \varnothing D_j [h8]	Housing- \varnothing D_H [H7]	Bush- \varnothing $D_{i,a}$ Ass. in H7 housing	Clearance C_D	Oil hole- \varnothing d_L									
	D_i	D_o								max. min.	max. min.	max. min.	max. min.	max. min.				
PM13560HX	135	140	2.435 2.380	60.50	h8	H7		0.343 0.130	No hole									
PM13580HX				59.50						135.000	140.040	135.280						
PM14050HX	140	145		80.50						140.000	145.040	140.280						
PM14060HX				79.50									139.937	140.130				
PM14080HX				50.50									150.000	155.040	150.280			
PM140100HX				49.50														
PM15050HX				60.50												150.000	155.040	150.130
PM15060HX				59.50														
PM15080HX	80.50																	
PM150100HX	79.50																	
PM16050HX	160	165		100.50						160.000	165.040	160.280						
PM16060HX				99.50									165.000	160.130				
PM16080HX				50.50														
PM160100HX				49.50														
PM17050HX	170	175		60.50						170.000	175.040	170.280						
PM17060HX				59.50									175.000	170.130				
PM17080HX				80.50														
PM170100HX				79.50														
PM18050HX	180	185		100.50						180.000	185.046	180.286						
PM18060HX				99.50									185.000	180.130				
PM18080HX				50.50														
PM180100HX				49.50														
PM19050HX	190	195		60.50						190.000	195.046	190.286						
PM19060HX				59.50									195.000	190.130				
PM19080HX			80.50															
PM190100HX			79.50															
PM190120HX			100.50	200.000	205.046	200.286												
PM20050HX			99.50				199.928	200.130										
PM20060HX	120.50																	
PM20080HX	119.50																	
PM200100HX	50.50																	
PM200120HX	49.50																	

9 Standard Products

Part No.	Nominal Diameter		Wall thickness s_3	Width B	Shaft- \varnothing D_J [h8]		Housing- \varnothing D_H [H7]		Bush- \varnothing $D_{L,a}$ Ass. in H7 housing		Clearance C_D	Oil hole- \varnothing d_L
	D_i	D_o			max. min.	max. min.	max. min.	max. min.	max. min.	max. min.		
PM22050HX	220	225	2.435 2.380	50.50	h8	220.000 219.928	H7	225.046 225.000	220.286 220.130	0.358 0.130	No hole	
PM22060HX				49.50								60.50
PM22080HX				59.50								80.50
PM220100HX				79.50								100.50
PM220120HX				99.50								120.50
PM24050HX	240	245		50.50		240.000 239.928		245.046 245.000	240.286 240.130			
PM24060HX				49.50								60.50
PM24080HX				59.50								80.50
PM240100HX				79.50								100.50
PM240120HX				99.50								120.50
PM25050HX	250	255		50.50		250.000 249.928		255.052 255.000	250.292 250.130	0.364 0.130		
PM25060HX				49.50								60.50
PM25080HX				59.50								80.50
PM250100HX				79.50								100.50
PM250120HX				99.50								120.50
PM26050HX	260	265		50.50		260.000 259.919		265.052 265.000	260.292 260.130			
PM26060HX				49.50								60.50
PM26080HX				59.50								80.50
PM260100HX				79.50								100.50
PM260120HX				99.50								120.50
PM28050HX	280	285	50.50	280.000 279.919	285.052 285.000	280.292 280.130	0.373 0.130					
PM28060HX			49.50					60.50				
PM28080HX			59.50					80.50				
PM280100HX			79.50					100.50				
PM280120HX			99.50					120.50				
PM30050HX	300	305	50.50	300.000 299.919	305.052 305.000	300.292 300.130						
PM30060HX			49.50					60.50				
PM30080HX			59.50					80.50				
PM300100HX			79.50					100.50				
PM300120HX			99.50					120.50				

9.2 MB-HI-EX cylindrical bushes

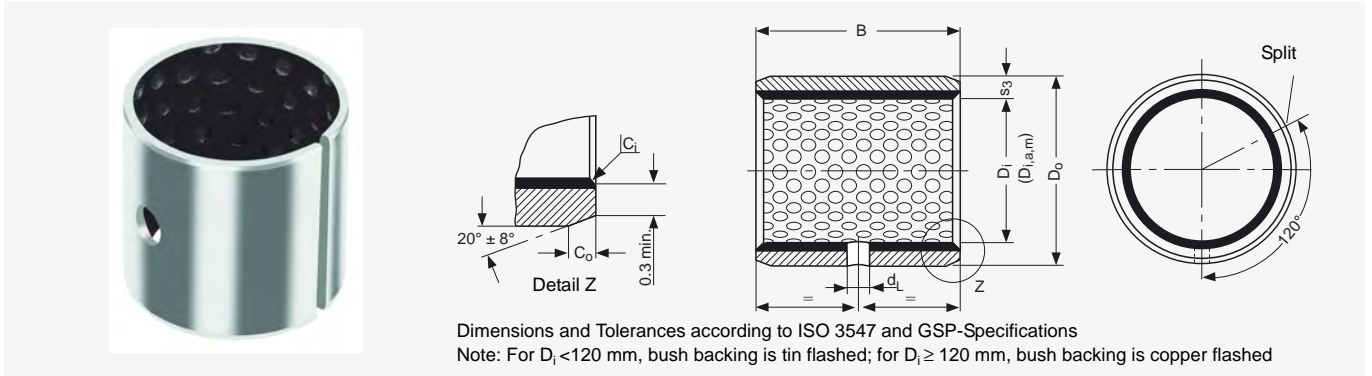

All dimensions in mm

Outside C_o and Inside C_i chamfers

Wall thickness s_3	C_o (a)		C_i (b)	Wall thickness s_3	C_o (a)		C_i (b)
	machined	rolled			machined	rolled	
1	0.6 ± 0.4	0.6 ± 0.4	-0.1 to -0.5	2	1.2 ± 0.4	1.0 ± 0.4	-0.1 to -0.7
1.5	0.6 ± 0.4	0.6 ± 0.4	-0.1 to -0.7	2.5	1.8 ± 0.6	1.2 ± 0.4	-0.2 to -1.0

a = Chamfer C_o machined or rolled at the option of the manufacturer

b = C_i can be a radius or a chamfer in accordance with ISO 13715

Part No.	Nominal Diameter		Wall thickness s_3	Width B	Shaft- \varnothing D_{jm} [d8]	Housing- \varnothing D_H [H7]		Bush- \varnothing $D_{i,a,m}$ Ass. in H7 housing	Clearance C_{Dm}	Oil hole- \varnothing d_L							
	D_i	D_o				max. min.	max. min.				max. min.	max. min.					
MB0808HX	8	10	1.108 1.082	8.25	d8	H7	10.015 10.000	8.015 8.000	0.077 0.040	No hole							
MB0810HX				10.25							7.960						
MB0812HX				12.25							7.938						
MB1010HX	10	12		11.75			9.960	12.018	10.018		0.080	3					
MB1012HX				15.25			9.938	12.000	10.000		0.040	4					
MB1015HX				14.75													
MB1020HX				20.25													
MB1210HX	12	14		19.75			d8	H7	14.018 14.000		12.018 12.000	0.095 0.050	3				
MB1212HX				10.25										11.950			
MB1215HX				9.75										11.923			
MB1220HX	12.25																
MB1225HX	11.75																
MB1415HX	14	16		15.25					d8		H7	16.018 16.000		14.018 14.000	0.095 0.050	4	
MB1420HX				14.75													13.950
MB1425HX				20.25													13.923
MB1510HX	15	17	19.75	d8	H7	17.018 17.000				15.018 15.000		3					
MB1512HX			25.25											14.950			
MB1515HX			24.75											14.923			
MB1525HX	10.25																
	9.75																
	12.25																
	11.75																
	15.25																
	14.75																
	25.25																
	24.75																

9 Standard Products

Part No.	Nominal Diameter		Wall thickness s_3	Width B	Shaft- \varnothing D_{Jm} [d8]		Housing- \varnothing D_H [H7]		Bush- \varnothing $D_{i.d.m}$ Ass. in H7 housing		Clearance C_{Dm}	Oil hole- \varnothing d_L
	D_i	D_o			max. min.	max. min.	max. min.	max. min.	max. min.	max. min.		
MB1615HX	16	18	1.108 1.082	15.25	15.950 15.923	18.018 18.000	16.018 16.000	0.095 0.050	4			
MB1620HX				14.75								
MB1625HX				20.25								
MB1815HX	19.75											
MB1820HX	25.25											
MB1825HX	24.75											
MB2010HX	20	23	1.608 1.576	10.25	19.935 19.902	23.021 23.000	20.021 20.000	0.119 0.065	6			
MB2015HX				9.75								
MB2020HX				15.25								
MB2025HX				14.75								
MB2030HX				20.25								
MB2215HX	19.75											
MB2220HX	25.25											
MB2225HX	24.75											
MB2230HX	30.25											
MB2415HX	29.75											
MB2420HX	15.25											
MB2425HX	14.75											
MB2430HX	20.25											
MB2515HX	25	28	2.108 2.072	19.75	24.935 24.902	28.021 28.000	25.021 25.000	0.119 0.065	6			
MB2520HX				20.25								
MB2525HX				15.25								
MB2530HX				14.75								
MB2820HX	28	32		20.25	27.935 27.902	32.025 32.000	28.021 28.000					
MB2825HX				19.75								
MB2830HX				25.25								
MB3020HX	30	34		30.25	30.000 29.967	34.025 34.000	30.021 30.000					
MB3030HX				29.75								
MB3040HX				40.25 39.75								

Part No.	Nominal Diameter		Wall thickness s_3 max. min.	Width B max. min.	Shaft- \varnothing D_{Jm} [d8] max. min.	Housing- \varnothing D_H [H7] max. min.	Bush- \varnothing $D_{i,a,m}$ Ass. in H7 housing max. min.	Clearance C_{Dm} max. min.	Oil hole- \varnothing d_L				
	D_i	D_o											
MB3220HX	32	36	2.108 2.072	20.25	d8	H7	32.025 32.000	0.144 0.080	6				
MB3230HX				19.75						31.920	36.025		
MB3235HX				30.25						31.881	36.000		
MB3240HX				29.75									
MB3520HX	35	39		20.25			34.920 34.881			39.025 39.000	35.025 35.000		
MB3530HX				19.75									
MB3550HX				30.25									
MB3720HX	37	41		20.25			36.920			41.025	37.025		
MB4020HX	40	44		19.75			39.920 39.881			44.025 44.000	40.025 40.000		
MB4030HX				30.25									
MB4040HX				29.75									
MB4050HX				40.25									
MB4520HX			39.75										
MB4520HX	45	50	20.25	44.920 44.881	50.025 50.000	45.025 45.000							
MB4530HX			19.75										
MB4540HX			30.25										
MB4545HX			29.75										
MB4550HX			40.25										
MB5040HX	50	55	39.75	49.920 49.881	55.030 55.000	50.025 50.000							
MB5060HX			60.25										
MB5520HX			59.75										
MB5520HX	55	60	20.25	54.900 54.854	60.030 60.000	55.030 55.000							
MB5525HX			19.75										
MB5530HX			25.25										
MB5540HX			24.75										
MB5550HX			30.25										
MB5560HX			29.75										
MB6030HX			40.25										
MB6040HX	60	65	39.75	59.900 59.854	65.030 65.000	60.030 60.000							
MB6060HX			60.25										
MB6070HX			59.75										
			70.25										
			69.75										
			2.634 2.588				0.176 0.100						

9 Standard Products

Part No.	Nominal Diameter		Wall thickness s_3	Width B	Shaft- \varnothing D_{Jm} [d8]		Housing- \varnothing D_H [H7]		Bush- \varnothing $D_{i.d.m}$ Ass. in H7 housing		Clearance C_{Dm}	Oil hole- \varnothing d_L
	D_i	D_o			max. min.	max. min.	max. min.	max. min.	max. min.	max. min.		
MB6540HX	65	70	2.634 2.568	40.25	d8	64.900 64.854	70.030 70.000	65.030 65.000	0.176 0.100	8		
MB6550HX				39.75								
MB6560HX				50.25								
MB6570HX				49.75								
MB7040HX	70	75		60.25		69.900 69.854	75.030 75.000	70.030 70.000				
MB7050HX				59.75								
MB7065HX				70.25								
MB7070HX				69.75								
MB7080HX	80.25											
MB7540HX	75	80		79.75		74.900 74.854	80.030 80.000	75.030 75.000				
MB7560HX				40.25								
MB7580HX				39.75								
MB8040HX				60.25								
MB8060HX	80	85		59.75		79.900 79.854	85.035 85.000	80.030 80.000				
MB8080HX				80.25								
MB80100HX				79.50								
MB8530HX				100.50								
MB8540HX	85	90		99.50		84.880 84.826	90.035 90.000	85.035 85.000				
MB8560HX				30.50								
MB8580HX				29.50								
MB85100HX			40.50									
MB9040HX	90	95	39.50	89.880 89.826	95.035 95.000	90.035 90.000						
MB9060HX			60.50									
MB9090HX			59.50									
MB90100HX			90.50									
MB9560HX	95	100	89.50	94.880 94.826	100.035 100.000	95.035 95.000						
MB95100HX			100.50									
MB10050HX			99.50									
MB10060HX			50.50									
MB10080HX	100	105	49.50	99.880 99.826	105.035 105.000	100.035 100.000						
MB10095HX			60.50									
MB100115HX			59.50									
			80.50									
			79.50									
			95.50									
			94.50									
			115.50									
			114.50									

Part No.	Nominal Diameter		Wall thickness s_3	Width B	Shaft- \varnothing D_{Jm} [d8]	Housing- \varnothing D_H [H7]	Bush- \varnothing $D_{i,a,m}$ Ass. in H7 housing	Clearance C_{Dm}	Oil hole- \varnothing d_L				
	D_i	D_o								max. min.	max. min.	max. min.	max. min.
MB10560HX	105	110	2.634 2.568	60.50	d8	H7	110.035 110.000	105.035 105.000	0.209 0.120	9.5			
MB105110HX				59.50							104.880	115.035	
MB105115HX				110.50							104.826	115.000	
MB11060HX	110	115		60.50							109.880	115.035	110.035
MB110115HX	59.50	109.826		115.000							110.000		
MB11550HX	115	120		115.50							114.880	120.035	115.035
MB11570HX	114.50	114.826	120.000	115.000									
MB12060HX	120	125	60.50	d8	H7	125.040 125.000	120.035 120.000	0.248 0.145	No hole				
MB120100HX			59.50							119.880	130.040		
MB125100HX	125	130	100.50			124.855	135.040			125.040			
MB13050HX	130	135	99.50			124.792	130.000			125.000			
MB13060HX			50.50			129.855	135.040			130.040			
MB130100HX			49.50			129.792	135.000			130.000			
MB13560HX	135	140	100.50	d8	H7	140.040 140.000	135.040 135.000	0.248 0.145	No hole				
MB13580HX			99.50							134.855	145.040		
MB14060HX			60.50							134.792	145.000	140.040	
MB140100HX	140	145	59.50			139.855	145.040			140.040			
MB15060HX	150	155	100.50			d8	H7			155.040 155.000	150.040 150.000	0.248 0.145	No hole
MB15080HX			60.50										
MB150100HX			59.50	149.792	155.000								
			80.50										
	79.50												
	100.50												
	99.50												

9.3 HI-EX Thrust Washers

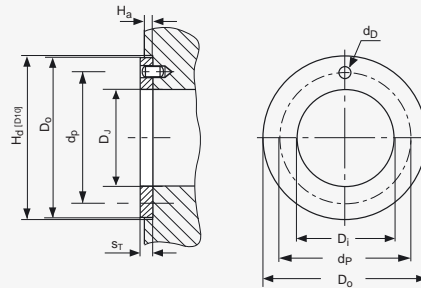

All dimensions in mm

Part No.	Inside- \varnothing D_i	Outside- \varnothing D_o	Thickness s_T	Dowel Hole		Recess Depth H_a
				$\varnothing d_D$	PCD- $\varnothing d_p$	
	max. min.	max. min.	max. min.	max. min.	max. min.	max. min.
WC08HX	10.25 10.00	20.00 19.75	1.58 1.49	No hole	No hole	1.20 0.95
WC10HX	12.25 12.00	24.00 23.75		1.875 1.625	18.12 17.88	
WC12HX	14.25 14.00	26.00 25.75		2.375 2.125	20.12 19.88	
WC14HX	16.25 16.00	30.00 29.75			22.12 21.88	
WC16HX	18.25 18.00	32.00 31.75		25.12 24.88		
WC18HX	20.25 20.00	36.00 35.75		3.375 3.125	28.12 27.88	
WC20HX	22.25 22.00	38.00 37.75			30.12 29.88	
WC22HX	24.25 24.00	42.00 41.75		4.375 4.125	33.12 32.88	
WC24HX	26.25 26.00	44.00 43.75			35.12 34.88	
WC25HX	28.25 28.00	48.00 47.75		61.12 60.88	38.12 37.88	
WC30HX	32.25 32.00	54.00 53.75			43.12 42.88	
WC35HX	38.25 38.00	62.00 61.75		65.12 64.88	50.12 49.88	
WC40HX	42.25 42.00	66.00 65.75			54.12 53.88	
WC45HX	48.25 48.00	74.00 73.75		76.12 75.88	61.12 60.88	
WC50HX	52.25 52.00	78.00 77.75	65.12 64.88			
WC60HX	62.25 62.00	90.00 89.75	2.60 2.51	1.70 1.45		

9.4 HI-EX Strip

HI-EX Strip sizes are available as Non-Standard products, on request.

10 Test Methods

10.1 Measurement of Wrapped Bushes

It is not possible to accurately measure the external and internal diameters of a wrapped bush in the free condition. In its free state a wrapped bush will not be perfectly cylindrical and the butt joint may be open. When correctly installed in a housing the butt joint will be tightly closed and the bush will conform to the housing.

For this reason the external diameter and internal diameter of a wrapped bush can only be checked with special gauges and test equipment.

The checking methods are defined in ISO 3547 Parts 1 to 7.

Test A of ISO 3547 Part 2

Checking the external diameter in a test machine with checking blocks and adjusting mandrel.

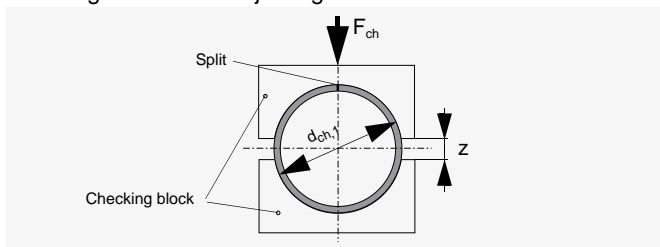

Fig. 34: Test A, presentation of data on drawing

Test A example for part no. PM2015HX	
Checking block and setting mandrel $d_{ch,1}$	23.062 mm
Test force F_{ch}	3500 N
Limits for Δz	0 and -0.065 mm
Bush Outside diameter D_o	23.035 to 23.075 mm

Table 7: Test A details calculated in accordance with ISO 3547-2

Test B (alternatively to Test A)

Check external diameter with GO and NOGO ring gauges.

Test C

Checking the internal diameter of a bush pressed into a ring gauge, which nominal diameter corresponds to the dimension specified in ISO 3547 Part 2 (Example: Prefinished standard wrapped bush with a D_i of 20 mm).

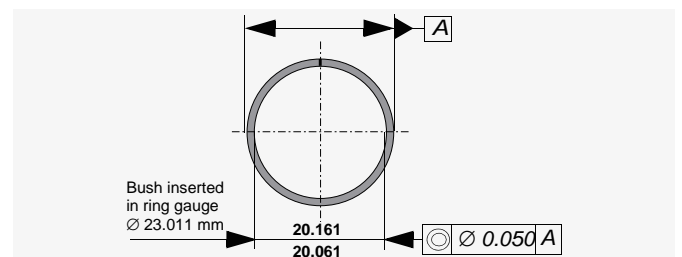

Fig. 35: Test C, presentation of data on drawing. Details shown are for a PM 20 series standard wrapped bush

Test D

Check external diameter by precision measuring tape.

11 Data Sheet for bearing design

Company:

Project:

Application:

Date:

Existing Design

New Design

Quantity

Annual

Contact name:

Tel.:

Fax:

Email:

Drawing attached

YES

NO

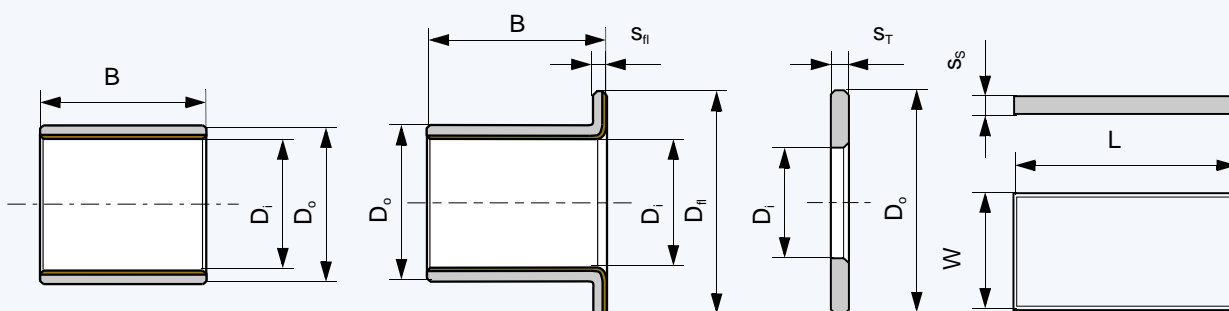

Cylindrical Bush

Flanged Bush

Thrust Washer

Slideplate

Special (Sketch)

Steady load

Rotating load

Rotational movement

Oscillating movement

Linear movement

Dimensions in mm

Inside Diameter D_i

Outside Diameter D_o

Length B

Flange Diameter D_{fl}

Flange Thickness s_{fl}

Length of slideplate L

Width of slideplate W

Thickness of slideplate s_s

Load

Radial load F [N]

Axial load F [N]

Movement

Rotational speed n [1/min]

Speed v [m/s]

Length of Stroke L_s [mm]

Frequency of Stroke [1/min]

Angular displacement ϕ [°]

Oscillating frequency n_{osc} [1/min]

Service hours per day

Continuous operation [h]

Intermittent operation [h]

Fits and Tolerances

Housing (\emptyset , tolerance) D_H

Shaft (\emptyset , tolerance) D_J

Mating surface

Material

Hardness HB/HRC

Surface roughness R_a [μ m]

Operating Environment

Temperature - ambient T_{amb}

Temperature - min/max T_{min}/T_{max}

Housing material

Assembly with good heat transfer properties

Assembly with poor heat transfer properties

Dry operation With lubricant

If grease, type with technical datasheet

If oil, type with technical datasheet

- Oil splash

- Oil bath

- Oil circulation

Service life

Required service life L_H [h]

Formula Symbols and Designations

Formula Symbol	Unit	Designation
a_B	-	Bearing size factor
a_E	-	High load factor
a_Q	-	Speed/Load factor
a_S	-	Surface finish factor
a_T	-	Temperature application factor
B	mm	Nominal bush width
C	1/min	Dynamic load frequency
C_D	mm	Installed diametral clearance
C_{Dm}	mm	Diametral clearance machined
C_i	mm	Total number of dynamic load cycles
C_o	mm	ID chamfer length
C_T	-	OD chamfer length
D_H	mm	Housing Diameter
D_i	mm	Nominal bush/thrust washer ID
$D_{i,a}$	mm	Bush ID when assembled in housing
$D_{i,a,m}$	mm	Bush ID assembled and machined
D_j	mm	Shaft diameter
D_{Jm}	mm	Shaft diameter for machined bushes
D_o	mm	Nominal bush/thrust washer OD
d_D	mm	Dowel hole diameter
d_L	mm	Oil hole diameter
d_P	mm	Pitch circle diameter for dowel hole
F	N	Bearing load
F_i	N	Insertion force
f	-	Friction
H_a	mm	Depth of Housing Recess (e.g. for thrust washers)
H_d	mm	Diameter of Housing Recess (thrust washers)
L	mm	Strip length
L_H	h	Bearing service life
L_{RG}	h	Relubrication interval

Formula Symbol	Unit	Designation
n	1/min	Rotational speed
n_{osc}	1/min	Oscillating movement frequency
p	MPa	Specific load
p_{lim}	MPa	Specific load limit
$p_{sta,max}$	MPa	Maximum static load
$p_{dyn,max}$	MPa	Maximum dynamic load
Q	-	Total number of cycles
R	-	Number of lubrication intervals
R_a	µm	Surface roughness (DIN 4768, ISO/DIN 4287/1)
s_3	mm	Bush wall thickness
s_s	mm	Strip thickness
s_T	mm	Thrust washer thickness
T	°C	Temperature
T_{amb}	°C	Ambient temperature
T_{max}	°C	Maximum temperature
T_{min}	°C	Minimum temperature
v	-	Sliding speed
u	m/s	speed factor
W	mm	Strip width
$W_{u min}$	mm	Minimum usable strip width
Z_T	-	Total number of oscillating movements
α_1	1/10⁶K	Coefficient of linear thermal expansion parallel to surface
α_2	1/10⁶K	Coefficient of linear thermal expansion normal to surface
σ_c	MPa	Compressive Yield strength
λ	W/mK	Thermal conductivity
φ	°	Angular displacement
η	Ns/mm²	Dynamic Viscosity

11 Data Sheet for bearing design

Your notes



11 Data Sheet for bearing design

Your notes



Product Information

GGB gives an assurance that the products described in this document have no manufacturing errors or material deficiencies.

The details set out in this document are registered to assist in assessing the material's suitability for the intended use. They have been developed from our own investigations as well as from generally accessible publications. They do not represent any assurance for the properties themselves.

Unless expressly declared in writing, GGB gives no warranty that the products described are suited to any particular purpose or specific operating circumstances. GGB accepts no liability for any losses, damages or costs however they may arise through direct or indirect use of these products.

GGB's sales and delivery terms and conditions, included as an integral part of quotations, stock and price lists, apply absolutely to all business conducted by GGB. Copies can be made available on request.

Products are subject to continual development. GGB retains the right to make specification amendments or improvements to the technical data without prior announcement.

Edition 2012 (This edition replaces earlier editions which hereby lose their validity).

Declaration on lead contents of GGB products/compliance with EU law

Since July 1, 2006 it has been prohibited under Directive 2002/95/EC (restriction of the use of certain hazardous substances in electrical and electronic equipment; ROHS Directive) to put products on the market that contain lead, mercury, cadmium, hexavalent chromium, polybrominated biphenyls (PBB) or polybrominated diphenyl ethers (PBDE).

Certain applications listed in the annex to the ROHS Directive are exempted. A maximum concentration value of 0.01% by weight and per homogeneous material, for cadmium and of 0.1% by weight and per homogeneous material, for lead, mercury, hexavalent chromium, PBB and PBDE shall be tolerated.

According to Directive 2000/53/EC on end-of life vehicles, since July 1, 2003 it has been prohibited to put on the market materials and components that contain lead, mercury, cadmium or hexavalent chromium. Due to an exceptional provision, lead-containing bearing shells and bushes could still be put on the market up until July 1, 2008. This general exception expired on July 1, 2008. A maximum concentration value of up to 0.1% by weight and per homogeneous material, for lead, hexavalent chromium and mercury shall be tolerated.

All products of GGB, with the exception of DU, DU-B, DB, SY and SP satisfy these requirements of Directives 2002/95/EC (ROHS Directive) and 2000/53/EC (End-of-life Vehicle Directive).

All products manufactured by GGB are also compliant with REACH Regulation (EC) No. 1 907/2006 of December 18, 2006.

HI-EX® and DS™ are trademarks of GGB.

Visit us on the internet:
www.ggbearings.com





an EnPro Industries company

The Global Leader in High Performance Bearing Solutions

GGB Heilbronn GmbH

Postfach 18 62 • D-74008 Heilbronn
Ochsenbrunnenstraße 9 • D-74078 Heilbronn
Industriegebiet Böllinger Höfe
Tel. +49 7131 269 0 • Fax +49 7131 269 500
eMail: germany@ggbearings.com • www.ggbearings.de



HB109ENG11-15HN