

<b>Engine</b>	Cummins 6CTAA8.3
<b>Rated Power</b>	160 kW (215 hp) @ 2,200 rpm
<b>Net Power</b>	144 kW (193 hp) @ 2,200 rpm
<b>Blade Width</b>	4,270 mm
<b>Maximum Speed</b>	42 km/h
<b>Draw Bar Pull</b>	90 kN
<b>Operating Weight</b>	16,500 kg

# 4215 MOTOR GRADER



TOUGH WORLD. TOUGH EQUIPMENT.

# 4215 SPECIFICATIONS >>>

## ENGINE

Emission Regulation	Tier 2 / Stage II
Make	Dongfeng Cummins
Model	6CTAA8.3
Rate Power	160 kW (215 hp) @ 2,200 rpm
Net Power	144 kW (193 hp) @ 2,200 rpm
Peak Torque	980 N . m @ 1,500 rpm
Torque Rise %	41 %
Number of Cylinders	6
Aspiration	turbo air-to-air aftercooled

## TRANSMISSION

Transmission Type	power shift
Transmission Configuration	6f / 3r
Torque Converter	three - member single turbine
Maximum Travel Speed, fwd	42 km/h
Maximum Travel Speed, rev	26 km/h
Number of Speeds, fwd	6
Number of Speeds, rev	3

## AXLES

Differential Type	limited slip standard
Final Drive Type	chain drive
Axle Oscillation	15°
Front Axle Type	all welded steel frame
Front Axle, Wheel Lean Angle	left / right 17°

## STEERING

Steering Relief Pressure	15-17 MPa
Minimum Turning Radius	7,800 mm
Steering Angle	±45°
Frame Articulation Angle	±20°

## BRAKES

Service Brake Type	shoe
--------------------	------

## TIRES

Tire Size	17.5-25 L3
-----------	------------

## HYDRAULIC SYSTEM

Main Pump Type	gear
Main Relief Pressure	18±0.5 MPa
Pilot Pump Flow	118 L/min

## TANDEM DRIVE PERFORMANCE

Height	600 mm
Width	210 mm
Center Distance	1,538 mm
Oscillating Angle	±15°

## MOLDBOARD PERFORMANCE

Bank Cut Angle	40-70°
Moldboard Lift Above Ground	450 mm
Moldboard Side Shift, right / left	725 / 675 mm
Maximum Sloping Angle	90°

Moldboard Standard Length	4,270 mm
Cutting Depth	555 mm
Circle Rotation	360°
Circle Diameter	1,455 mm

## WORKING CAPACITIES

Maximum Draw Pull	90 kN
Cutting Pressure	7,800 kg

## DIMENSIONS

Wheelbase	6,230 mm
Overall Length	9,385 mm
Overall Height with Cab	3,580 mm
Clearance under Front Axle	580 mm

## OPERATING WEIGHTS

Operating Weight	16,500 kg
On Front Wheels	4,950 kg
On Rear Wheels	11,550 kg

## SERVICE CAPACITIES

Fuel Tank	270 L
Engine Oil	22 L
Cooling System	45 L
Hydraulic Reservoir	186 L
Transmission And Torque Converter	45 L
Tandems, Each	28 L

## OPTIONAL EQUIPMENT

- Rear Ripper
- Front Dozer
- Ultrasonic Automatic Leveling System
- Rotary Beacon
- ROPS/FOPS
- Frictional flake worm box
- G2 tyre & Radial & Tubeless tyre

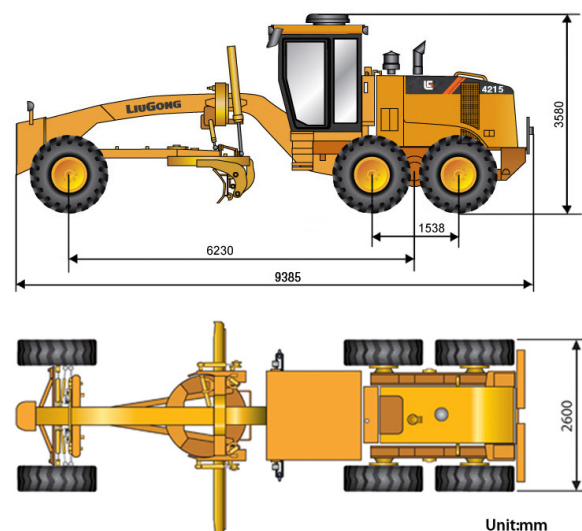

Unit:mm

## Guangxi Liugong Machinery Co., Ltd.

No. 1 Liutai Road, Liuzhou, Guangxi 545007, PR China  
 T: +86 772 3886124 E: overseas@liugong.com  
 www.liugong.com

Specifications and designs are subject to change without notice. Machines shown may include optional equipment.

06/2014 Designed by Liugong