

□ 60

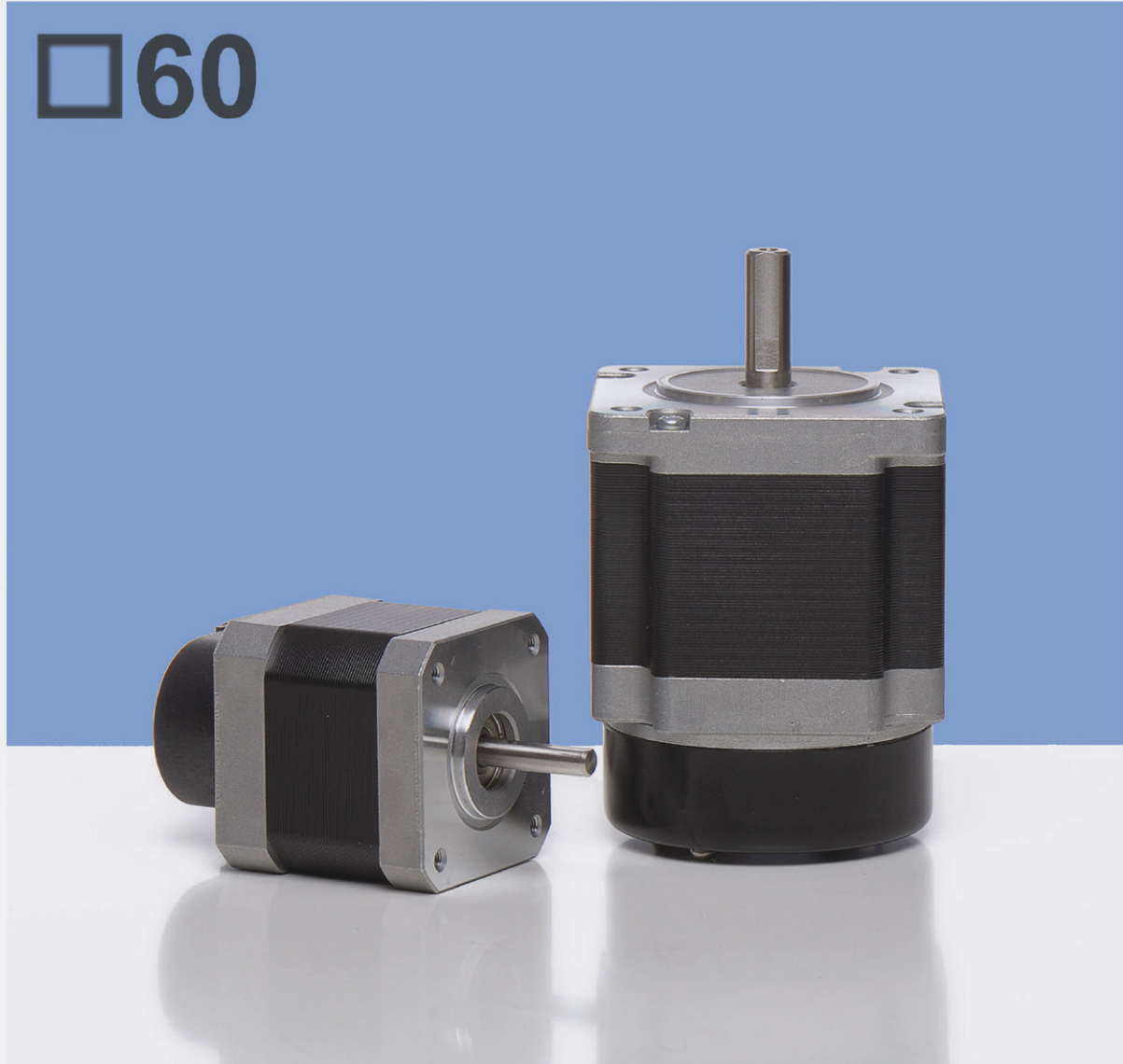

## STEPPING MOTORS

2-Phase Step Motor | Flange 60mm | 1.15 - 3.30 Nm  
with Encoder

## SCHRITTMOTOREN

2-Phasen Schrittmotoren | Flansch 60mm | 1,15 - 3,30 Nm  
mit Encoder



## HECM26... Series

2-Phase Step Motor with Encoder  
[1.8° High-Torque-Version]

Model P = Line Drive 200 Counts/Turn	● Bipolar Parallel				● Bipolar Seriell				● Unipolar				Speed Torque
	Holding Torque [Nm]	Current / Phase [A]	Resistance / Phase [Ohm]	Inductance / Phase [mH]	Holding Torque [Nm]	Current / Phase [A]	Resistance / Phase [Ohm]	Inductance / Phase [mH]	Holding Torque [Nm]	Current / Phase [A]	Resistance / Phase [Ohm]	Inductance / Phase [mH]	
HECM264-E2.0P2200	1.15	2.8	0.73	2.1	1.15	1.4	2.9	8.4	0.85	2.0	1.45	2.1	A1
HECM266-E2.0P2200	1.82	2.8	1.0	3.8	1.82	1.4	4.0	15.2	1.35	2.0	2.0	3.8	B1
HECM266-E3.0P2200	1.82	4.2	0.43	1.6	1.82	2.1	1.7	6.4	1.35	3.0	0.85	1.6	B2
HECM267-E2.4P2200	2.35	3.5	0.75	3.1	2.35	1.75	3.0	12.4	1.75	2.45	1.5	3.1	C1
HECM267-E3.0P2200	2.35	4.2	0.5	2.0	2.35	2.1	2.0	8.0	1.75	3.0	1.0	2.0	C2
HECM269-E2.4P2200	3.30	3.5	1.0	5.0	3.30	1.75	4.0	20.0	2.45	2.45	2.0	5.0	D1
HECM269-E3.0P2200	3.30	4.2	0.65	3.2	3.30	2.1	2.6	12.8	2.45	3.0	1.3	3.2	D2

Model	Number of Leads	Weight of Motor & Encoder	Size Length	Rotor Inertia
HECM264	8	0.70 kg	66.7 mm	$280 \times 10^{-7} \text{ kgm}^2$
HECM266	8	0.95 kg	77.2 mm	$450 \times 10^{-7} \text{ kgm}^2$
HECM267	8	1.20 kg	88.2 mm	$570 \times 10^{-7} \text{ kgm}^2$
HECM269	8	1.55 kg	108,2 mm	$900 \times 10^{-7} \text{ kgm}^2$

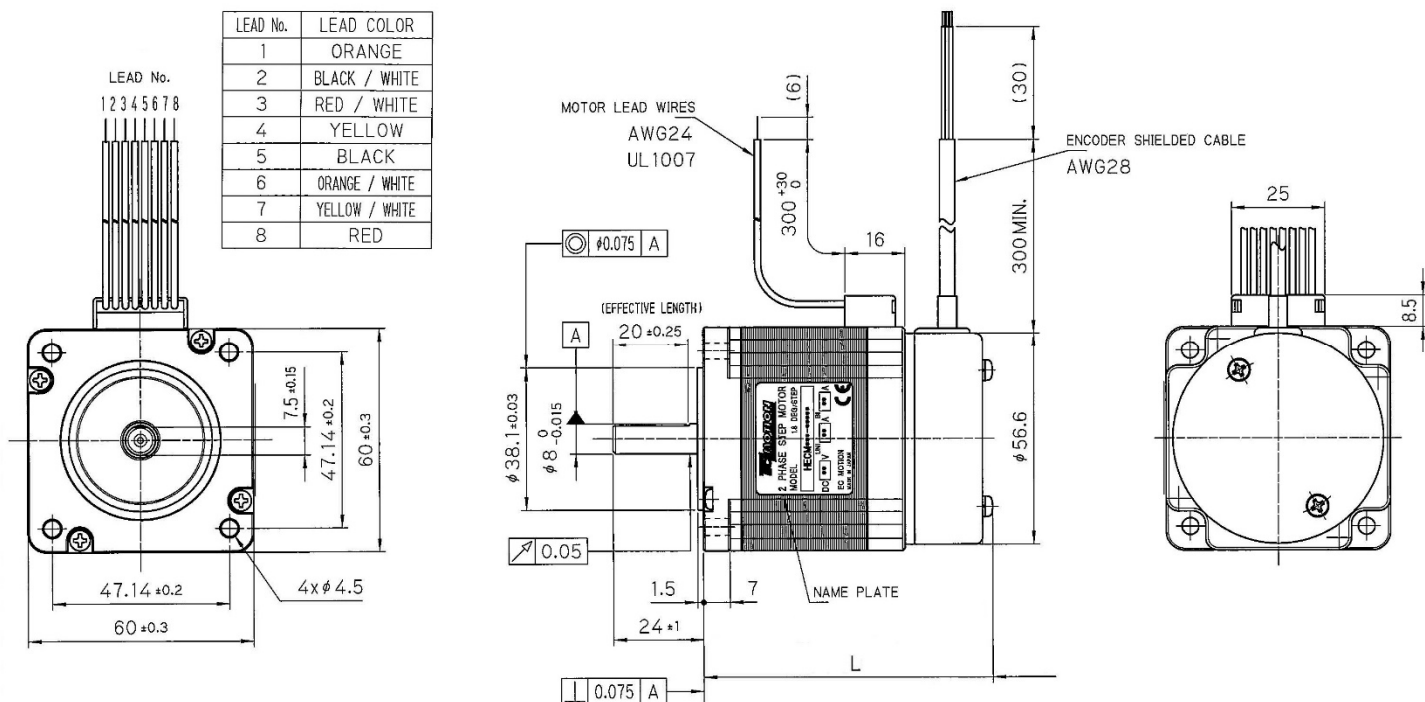

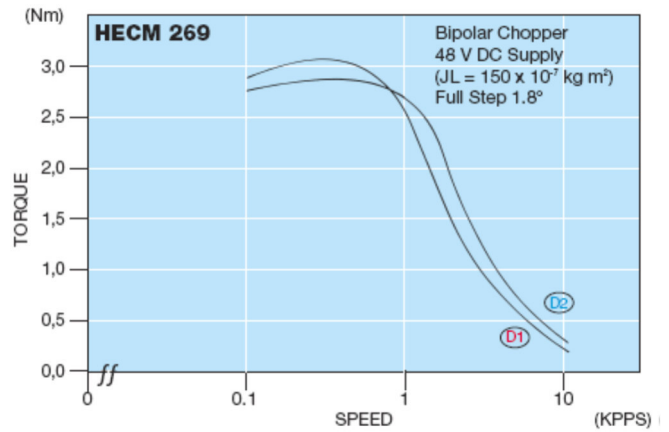
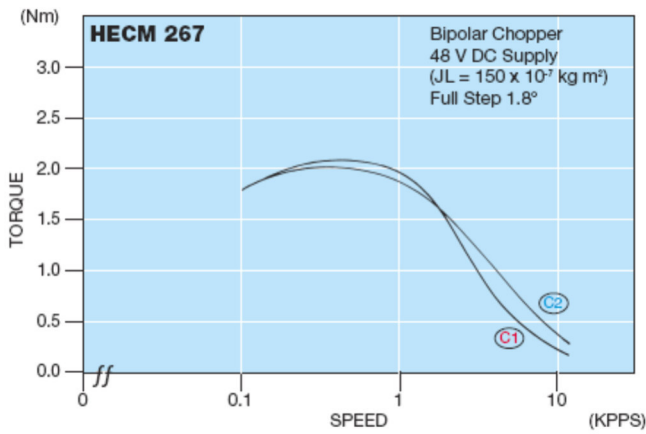
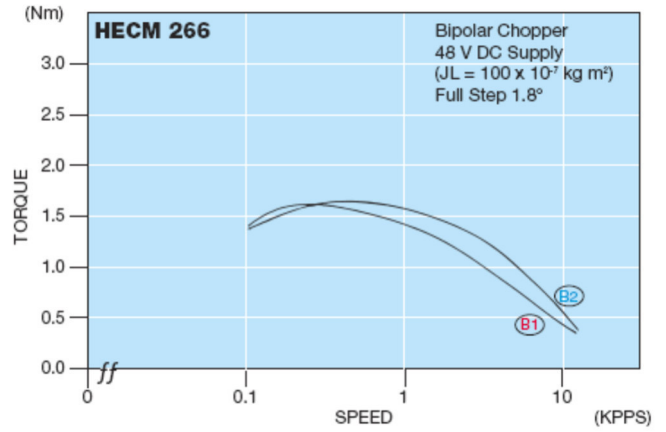
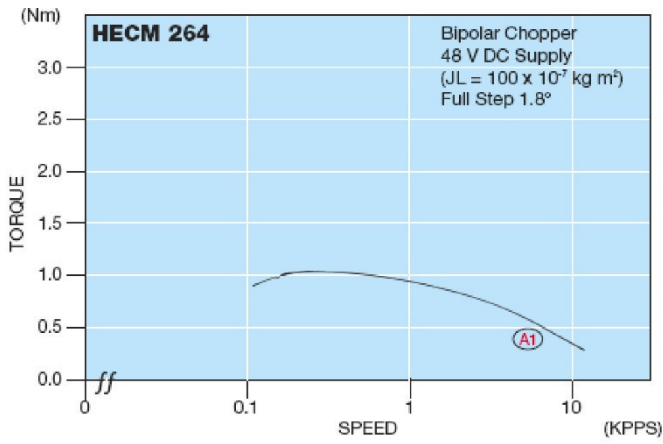

## Step Motor - Color of lead wires (Encoder see page 3/3)

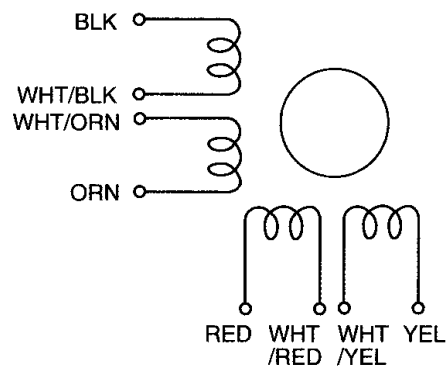

Planetary Gears are optionally available



## Encoder Performance

Operating Temp.range : 0°C – 85°C  
 Supply : DC 5V ± 5% , 100mA max  
 Resolution : 200 Counts / Turn  
 Frequency Response : 100K Hz max.  
 A phase difference : 1/4 P ± 1/8 P  
 Code : Incremental A.B (2Ch.)

Output Signal : when output is high : DC 2.4V min  
 Output Signal : when output is low : DC 0.4V max  
 Sinking & Output Current : typical ± 20mA max  
 Rise & Fall Times : 1 µsec max  
 Moment of inertia : 5 g-cm<sup>2</sup> max Encoder only  
 Output Circuit : Line Driver AM26C3IIB

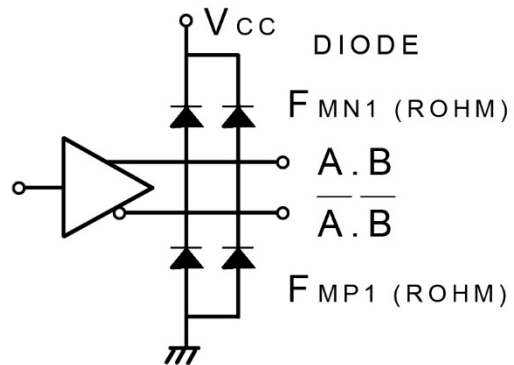
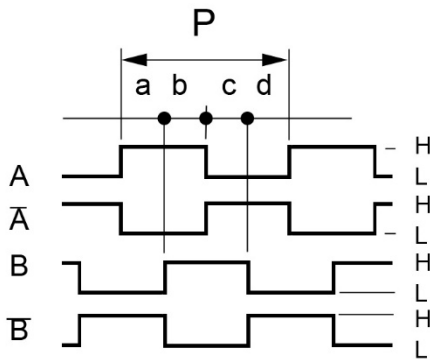

CW Rotation viewed from mounting end. Encoder signal A and B position is “H” at Motor 2Phase on.

### Color of Leadwires and Funktion :

DC 5V = red	A phase = brown	$\bar{A}$ phase = orange
GND = blue	B phase = yellow	$\bar{B}$ phase = gray

(Old-Version)

A phase = brown	$\bar{A}$ phase = orange
B phase = yellow	$\bar{B}$ phase = white
DC 5V = red	GND = black