



STEPPING MOTORS

2-Phase Hybrid Type

1.8° and 0.9° Full Step Angle

SCHRITTMOTOREN

2-Phasen Hybrid-Schrittmotoren

1,8° and 0,9° Vollschrittwinkel

STEPPING MOTORS

SPECIFICATIONS

Full Step Series	Model	● Bipolar Parallel				● Bipolar Serial				● Unipolar				Length [mm]	Page
		Holding Torque [Nm]	Current/Phase [A]	Resistance/Phase [Ohm]	Inductance/Phase [mH]	Holding Torque [Nm]	Current/Phase [A]	Resistance/Phase [Ohm]	Inductance/Phase [mH]	Holding Torque [Nm]	Current/Phase [A]	Resistance/Phase [Ohm]	Inductance/Phase [mH]		
1.8° HECM □ 60	HECM264-E2.0 (A/B)	1.15	2.8	0.73	2.1	1.15	1.4	2.9	8.4	0.85	2.0	1.45	2.1	43.5	4 / 5
	HECM264-E3.0 (A/B)	1.15	4.2	0.33	1.0	1.15	2.1	1.3	4.0	0.85	3.0	0.65	1.0	43.5	
	HECM266-E2.0 (A/B)	1.82	2.8	1.0	3.8	1.82	1.4	4.0	15.2	1.35	2.0	2.0	3.8	54	
	HECM266-E3.0 (A/B)	1.82	4.2	0.43	1.6	1.82	2.1	1.7	6.4	1.35	3.0	0.85	1.6	54	
	HECM267-E2.4 (A/B)	2.35	3.5	0.75	3.1	2.35	1.75	3.0	12.4	1.75	2.45	1.5	3.1	65	
	HECM267-E3.0 (A/B)	2.35	4.2	0.5	2.0	2.35	2.1	2.0	8.0	1.75	3.0	1.0	2.0	65	
	HECM269-E2.4 (A/B)	3.30	3.5	1.0	5.0	3.30	1.75	4.0	20.0	2.45	2.45	2.0	5.0	85	
	HECM269-E3.0 (A/B)	3.30	4.2	0.65	3.2	3.30	2.1	2.6	12.8	2.45	3.0	1.3	3.2	85	
1.8° SECM □ 56.4	SECM264-E1.0 (A/B)	0.50	1.4	2.6	5.4	0.50	0.7	10.4	21.6	0.39	1.0	5.2	5.4	39	6 / 7
	SECM264-E2.0 (A/B)	0.50	2.8	0.7	1.4	0.50	1.4	2.8	5.6	0.39	2.0	1.4	1.4	39	
	SECM264-E3.0 (A/B)	0.50	4.2	0.3	0.5	0.50	2.1	1.2	2.0	0.39	3.0	0.6	0.5	39	
	SECM266-E1.0 (A/B)	1.17	1.4	3.6	11.0	1.17	0.7	14.4	44.0	0.90	1.0	7.2	11.0	54	
	SECM266-E2.0 (A/B)	1.17	2.8	0.9	2.5	1.17	1.4	3.6	10.0	0.90	2.0	1.8	2.5	54	
	SECM266-E3.0 (A/B)	1.17	4.2	0.4	1.2	1.17	2.1	1.6	4.8	0.90	3.0	0.8	1.2	54	
	SECM268-E1.0 (A/B)	1.75	1.4	4.1	14.0	1.75	0.7	16.4	56.0	1.35	1.0	8.2	14.0	76	
	SECM268-E2.0 (A/B)	1.75	2.8	1.2	3.6	1.75	1.4	4.6	14.4	1.35	2.0	2.3	3.6	76	
	SECM268-E2.3 (A/B)	1.75	3.3	0.9	2.8	1.75	1.65	3.4	11.2	1.35	2.3	1.7	2.8	76	
SECM268-E3.0 (A/B)	1.75	4.2	0.5	1.6	1.75	2.1	2.0	6.4	1.35	3.0	1.0	1.6	76		
1.8° SECM □ 86	SECM296-E4.5 (AE/BE)	3.70	6.4	0.2	1.6	3.70	3.2	0.8	6.4	2.75	4.5	0.4	1.6	79	8 / 9
	SECM299-E4.5 (AE/BE)	7.30	6.4	0.3	3.1	7.30	3.2	1.2	12.4	5.40	4.5	0.6	3.1	117,5	
	SECM299-E6.4 (AE/BE)	6.90	9.0	0.16	1.1	6.90	4.5	0.64	4.4	5.00	6.4	0.32	1.1	117,5	
	SECM2913-E4.0 (AE/BE)	10.20	5.7	0.43	4.6	10.20	2.8	1.7	18.4	7.40	4.0	0.85	4.6	156	
	SECM2913-E6.4 (AE/BE)	9.80	9.0	0.19	1.7	9.80	4.5	0.76	6.8	7.20	6.4	0.38	1.7	156	
	SECM296-E4.5AE-T	3.70	6.4	0.2	1.6	3.70	3.2	0.8	6.4	2.75	4.5	0.4	1.6	112.5	
	SECM299-E4.5AE-T	7.30	6.4	0.3	3.1	7.30	3.2	1.2	12.4	5.40	4.5	0.6	3.1	151	
	SECM299-E6.4AE-T	6.90	9.0	0.16	1.1	6.90	4.5	0.64	4.4	5.00	6.4	0.32	1.1	151	
	SECM2913-E4.0AE-T	10.20	5.7	0.43	4.6	10.20	2.8	1.7	18.4	7.40	4.0	0.85	4.6	189.5	
SECM2913-E6.4AE-T	9.80	9.0	0.19	1.7	9.80	4.5	0.76	6.8	7.20	6.4	0.38	1.7	189.5		
0.9° SECM □ 56.4	SECM264M-E1.0 (A/B)	0.55	1.4	2.8	8.4	0.55	0.7	11.2	33.6	0.44	1.0	5.6	8.4	39	12 / 13
	SECM264M-E2.0 (A/B)	0.55	2.8	0.7	2.2	0.55	1.4	2.8	8.8	0.44	2.0	1.4	2.2	39	
	SECM264M-E3.0 (A/B)	0.55	4.2	0.3	0.9	0.55	2.1	1.2	3.6	0.44	3.0	0.6	0.9	39	
	SECM266M-E1.0 (A/B)	1.25	1.4	3.6	23.1	1.25	0.7	14.4	92.4	0.95	1.0	7.2	23.1	54	
	SECM266M-E2.0 (A/B)	1.25	2.8	0.9	5.9	1.25	1.4	3.6	23.6	0.95	2.0	1.8	5.9	54	
	SECM266M-E3.0 (A/B)	1.25	4.2	0.4	2.6	1.25	2.1	1.6	10.4	0.95	3.0	0.8	2.6	54	
	SECM268M-E2.0 (A/B)	1.95	2.8	1.15	7.8	1.95	1.4	4.6	31.2	1.45	2.0	2.3	7.8	76	
	SECM268M-E2.4 (A/B)	1.95	3.5	0.75	5.0	1.95	1.75	3.0	20.0	1.45	2.45	1.5	5.0	76	
SECM268M-E3.0 (A/B)	1.95	4.2	0.5	3.5	1.95	2.1	2.0	14.0	1.45	3.0	1.0	3.5	76		
1.8° ECM □ 56.4	ECM264-E1.5 (A/B)	0.40	2.1	0.75	1.8	0.40	1.05	3.0	7.2	0.29	1.5	1.5	1.8	38	14 / 15
	ECM265-E1.0 (A/B)	0.70	1.4	2.5	9.0	0.70	0.7	10.0	36.0	0.50	1.0	5.0	9.0	51	
	ECM265-E2.6 (A/B)	0.60	3.7	0.36	0.9	0.60	1.85	1.44	3.6	0.45	2.6	0.72	0.9	51	
	ECM266-E1.2 (A/B)	0.80	1.7	2.5	9.0	0.80	0.85	10.0	36.0	0.60	1.2	5.0	9.0	51	
	ECM268-E1.6 (A/B)	1.25	2.3	1.6	5.5	1.25	1.15	6.4	22.0	0.95	1.6	3.2	5.5	76	
	ECM268-E2.3 (A/B)	1.25	3.3	0.85	3.5	1.25	1.65	3.4	14.0	0.95	2.3	1.7	3.5	76	
	ECM2610-E2.9 (A/B)	1.65	4.1	0.6	2.2	1.65	2.05	2.4	8.8	1.25	2.9	1.2	2.2	102	
Stepping Motor with Encoder															
1.8° SECM □ 56.4	SECM264-E2.0P2200	0.50	2.8	0.7	1.4	0.50	1.4	2.8	5.6	0.39	2.0	1.4	1.4	60	16
	SECM266-E2.0P2200	1.17	2.8	0.9	2.5	1.17	1.4	3.6	10.0	0.90	2.0	1.8	2.5	75	
	SECM268-E2.3P2200	1.75	3.3	0.9	2.8	1.75	1.65	3.4	11.2	1.35	2.3	1.7	2.8	97	
1.8° ECM □ 56.4	ECM264-E1.5P2200	0.40	2.1	0.75	1.8	0.40	1.05	3.0	7.2	0.29	1.5	1.5	1.8	62	16
	ECM265-E1.0P2200	0.70	1.4	2.5	9.0	0.70	0.7	10.0	36.0	0.50	1.0	5.0	9.0	74	
	ECM265-E2.6P2200	0.60	3.7	0.36	0.9	0.60	1.85	1.44	3.6	0.45	2.6	0.72	0.9	74	
	ECM266-E1.2P2200	0.80	1.7	2.5	9.0	0.80	0.85	10.0	36.0	0.60	1.2	5.0	9.0	74	
	ECM268-E2.3P2200	1.25	3.3	0.85	3.5	1.25	1.65	3.4	14.0	0.95	2.3	1.7	3.5	99	
	ECM2610-E2.9P2200	1.65	4.1	0.6	2.2	1.65	2.05	2.4	8.8	1.25	2.9	1.2	2.2	125	

(A/B) or (AE/BE) → A and AE = Single Shaft, B and BE = Double Shaft
(A/B) oder (AE/BE) → A und AE = Einzelwelle, B und BE = Doppelwelle

Planetary Gear see Page 17 - 21
Planetengetriebe siehe Seite 17 - 21

Driver Electronics see Page 22
Treiber Elektronik siehe Seite 22

PRODUCT NUMBER CODE

S E C M 2 6 5 M - E 1.0 A - T

- T = Terminal Box
Anschlußkasten
- Shaft Type: A/AE = Single Shaft Welle: A/AE = Einzelwelle
 B/BE = Double Shaft B/BE = Doppelwelle
 P = Encoder P = Drehgeber
- Current per phase (Unipolar)
Strom pro Phase bei unipolarem Betrieb
- 8 Leadwires
8 Anschlußdrähte
- Full Step Angle: No Letter = 1.8°, M = 0.9°
Vollschrittwinkel: Ohne Buchstabe = 1,8°, M = 0,9°
- Code of Motor Length: ex. 5 = approx. 5 cm
Motorlängenkodierung: z. B. 5 = ca. 5 cm
- Mounting Size: 6 = 56 x 56 mm, or 60 x 60 mm, 9 = 86 x 86 mm
Flanschmaß: 6 = 56 x 56 mm, oder 60 x 60 mm, 9 = 86 x 86 mm
- Number of phase: 2 = 2 phase motor
Anzahl der Phasen: 2 = 2 Phasenmotor
- EC Motion Stepping Motor**
- S or H = High Torque Series
S oder H = Drehmomentverstärkte Serie
- No Letter = Standard Series
Ohne Buchstabe = Standardserie

Stepping Motors are motors which can be directly controlled by digital signals and rotate at constant angles according to a pulse signal. These motors specified by EC Motion have been used in various application to control angle, speed and position. A full line of various models is available with superior features, excellent torque characteristics and high reliability in order to meet the requirements of your specific application.

Schrittmotoren haben den Vorteil, dass sie sich direkt durch digitale Signale steuern lassen und um einen konstanten Winkel drehen. EC Motion Schrittmotoren werden zu Geschwindigkeits- und Positionskontrolle in den unterschiedlichsten Anwendungen eingesetzt. Eine große Palette verschiedener Modelle mit hervorragenden Eigenschaften z. B. hohes Drehmoment, lange Lebensdauer, hohe Zuverlässigkeit stehen Ihnen zur Realisierung Ihrer speziellen Antriebsanforderungen zur Verfügung.

OPERATION

Operation of 2 phase Stepping Motors

Stepping Motors operate on Phase-Switched DC Power. The motor shaft advances 200 steps per revolution with 1.8° motor when a Full-Step mode is used, and 400 steps per revolution with 0.9° motor. When a Half-Step mode is used, 400 steps per revolution with 1.8° motor, 800 steps with 0.9° motor.

Arbeitsweise der 2-Phasen Schrittmotoren

Schrittmotoren benötigen zum Betrieb eine geschaltete Gleichspannung. Die Motorwelle eines 1,8° Schrittmotors führt bei Vollschrittbetrieb 200 Schritte, die eines 0,9° Motors 400 Schritte pro Umdrehung aus. Bei Halbschrittbetrieb verdoppeln sich die oben genannten Schritte auf 400 Schritte bei einem 1,8° Motor und auf 800 Schritte bei einem 0,9° Motor.

CONSTRUCTIONS

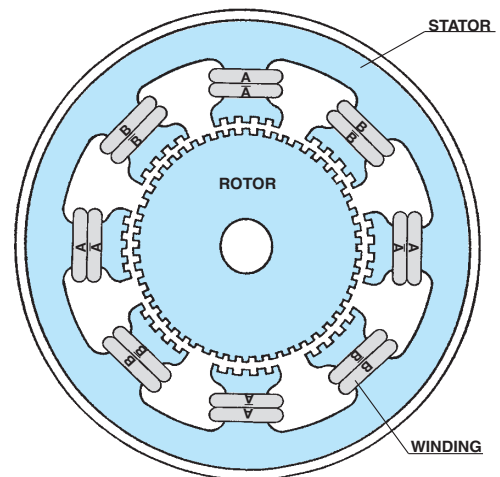

UNI-POLAR DRIVE CIRCUIT

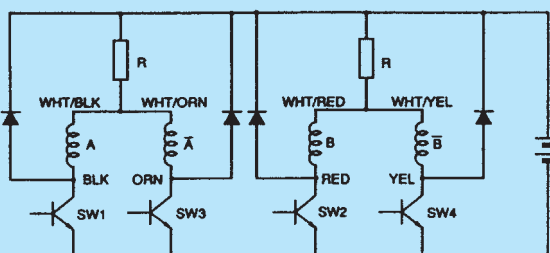

BI-POLAR (PARALLEL) DRIVE CIRCUIT

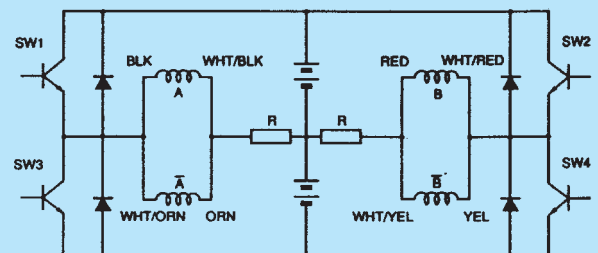

STEPPING MOTORS

□ 60 mm HECM-SPECIFICATIONS

1.8° HIGH-TORQUE 2 PHASE STEPPING MOTOR

Model A = Single Shaft B = Double Shaft	● Bipolar Parallel				● Bipolar Serial				● Unipolar				Torque Speed- curve
	Holding Torque [Nm]	Current/ Phase [A]	Resistance/ Phase [Ohm]	Inductance/ Phase [mH]	Holding Torque [Nm]	Current/ Phase [A]	Resistance/ Phase [Ohm]	Inductance/ Phase [mH]	Holding Torque [Nm]	Current/ Phase [A]	Resistance/ Phase [Ohm]	Inductance/ Phase [mH]	
HECM264-E2.0 (A/B)	1.15	2.8	0.73	2.1	1.15	1.4	2.9	8.4	0.85	2.0	1.45	2.1	(A1)
HECM264-E3.0 (A/B)	1.15	4.2	0.33*	1.0	1.15	2.1	1.3*	4.0	0.85	3.0	0.65*	1.0	(A2)

Number of Leads	Weight of Motor	Size Length	Rotor Inertia
8	0.6 kg	60 x 60 x 43,5 mm	280 x 10 ⁻⁷ kgm ²

Resistance / Phase (Ω) = ± 10%, (* ± 15%), Inductance / Phase (mH) = ± 20%

Model A = Single Shaft B = Double Shaft	● Bipolar Parallel				● Bipolar Serial				● Unipolar				Torque Speed- curve
	Holding Torque [Nm]	Current/ Phase [A]	Resistance/ Phase [Ohm]	Inductance/ Phase [mH]	Holding Torque [Nm]	Current/ Phase [A]	Resistance/ Phase [Ohm]	Inductance/ Phase [mH]	Holding Torque [Nm]	Current/ Phase [A]	Resistance/ Phase [Ohm]	Inductance/ Phase [mH]	
HECM266-E2.0 (A/B)	1.82	2.8	1.0	3.8	1.82	1.4	4.0	15.2	1.35	2.0	2.0	3.8	(B1)
HECM266-E3.0 (A/B)	1.82	4.2	0.43*	1.6	1.82	2.1	1.7*	6.4	1.35	3.0	0.85*	1.6	(B2)

Number of Leads	Weight of Motor	Size Length	Rotor Inertia
8	0.85 kg	60 x 60 x 54 mm	450 x 10 ⁻⁷ kgm ²

Resistance / Phase (Ω) = ± 10%, (* ± 15%), Inductance / Phase (mH) = ± 20%

Model A = Single Shaft B = Double Shaft	● Bipolar Parallel				● Bipolar Serial				● Unipolar				Torque Speed- curve
	Holding Torque [Nm]	Current/ Phase [A]	Resistance/ Phase [Ohm]	Inductance/ Phase [mH]	Holding Torque [Nm]	Current/ Phase [A]	Resistance/ Phase [Ohm]	Inductance/ Phase [mH]	Holding Torque [Nm]	Current/ Phase [A]	Resistance/ Phase [Ohm]	Inductance/ Phase [mH]	
HECM267-E2.4 (A/B)	2.35	3.5	0.75	3.1	2.35	1.75	3.0	12.4	1.75	2.45	1.5	3.1	(C1)
HECM267-E3.0 (A/B)	2.35	4.2	0.5*	2.0	2.35	2.1	2.0*	8.0	1.75	3.0	1.0*	2.0	(C2)

Number of Leads	Weight of Motor	Size Length	Rotor Inertia
8	1.1 kg	60 x 60 x 65 mm	570 x 10 ⁻⁷ kgm ²

Resistance / Phase (Ω) = ± 10%, (* ± 15%), Inductance / Phase (mH) = ± 20%

Model A = Single Shaft B = Double Shaft	● Bipolar Parallel				● Bipolar Serial				● Unipolar				Torque Speed- curve
	Holding Torque [Nm]	Current/ Phase [A]	Resistance/ Phase [Ohm]	Inductance/ Phase [mH]	Holding Torque [Nm]	Current/ Phase [A]	Resistance/ Phase [Ohm]	Inductance/ Phase [mH]	Holding Torque [Nm]	Current/ Phase [A]	Resistance/ Phase [Ohm]	Inductance/ Phase [mH]	
HECM269-E2.4 (A/B)	3.30	3.5	1.0	5.0	3.30	1.75	4.0	20.0	2.45	2.45	2.0	5.0	(D1)
HECM269-E3.0 (A/B)	3.30	4.2	0.65*	3.2	3.30	2.1	2.6*	12.8	2.45	3.0	1.3*	3.2	(D2)

Number of Leads	Weight of Motor	Size Length	Rotor Inertia
8	1.45 kg	60 x 60 x 85 mm	900 x 10 ⁻⁷ kgm ²

Resistance / Phase (Ω) = ± 10%, (* ± 15%), Inductance / Phase (mH) = ± 20%

TORQUE VS. SPEED CHARACTERISTIC

Nm/KPPS (1000 PULSE/SECOND)

DIMENSIONS

UNIT = mm

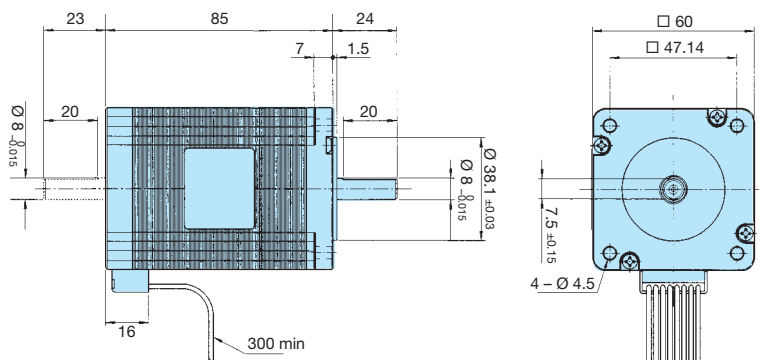
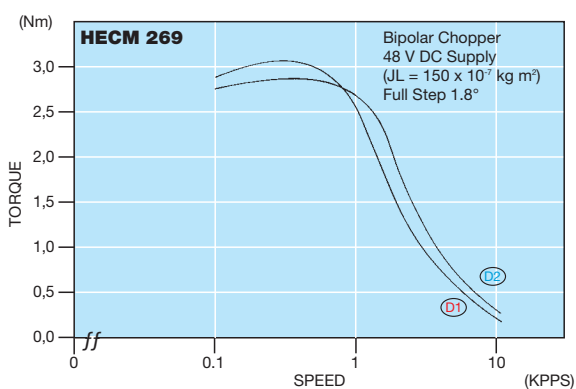
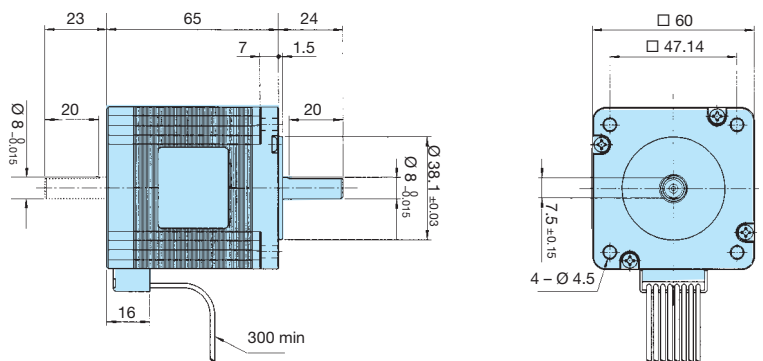
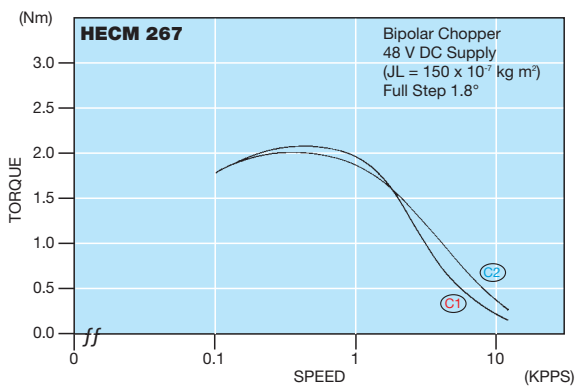
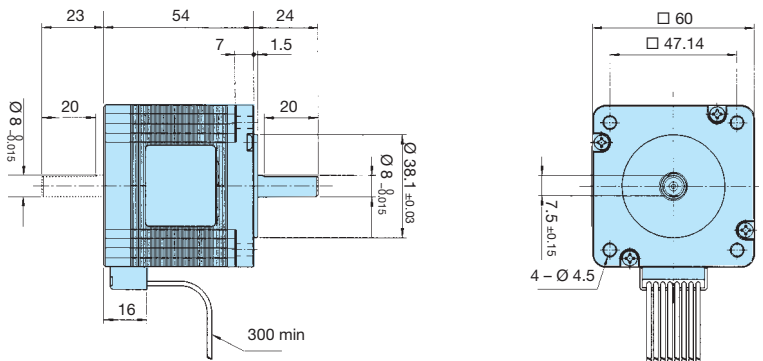
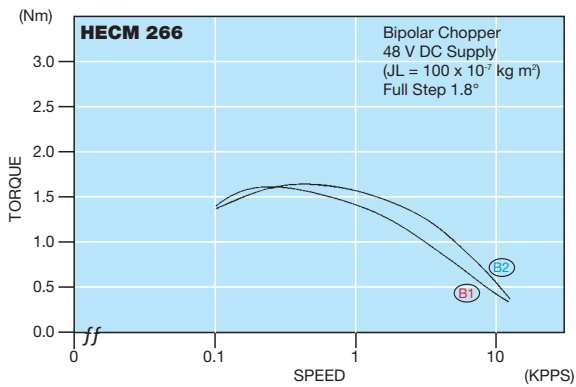
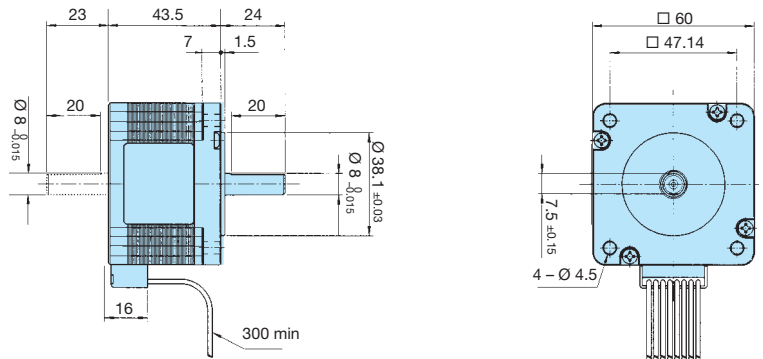
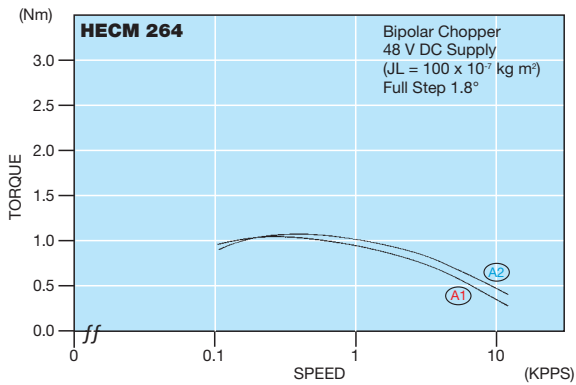

STEPPING MOTORS

□ 56.4 mm SECM-SPECIFICATIONS

1.8° HIGH-TORQUE 2 PHASE STEPPING MOTOR

Model A = Single Shaft B = Double Shaft	● Bipolar Parallel				● Bipolar Serial				● Unipolar				Torque Speed-curve
	Holding Torque [Nm]	Current/Phase [A]	Resistance/Phase [Ohm]	Inductance/Phase [mH]	Holding Torque [Nm]	Current/Phase [A]	Resistance/Phase [Ohm]	Inductance/Phase [mH]	Holding Torque [Nm]	Current/Phase [A]	Resistance/Phase [Ohm]	Inductance/Phase [mH]	
SECM264-E1.0 (A/B)	0.50	1.4	2.6	5.4	0.50	0.7	10.4	21.6	0.39	1.0	5.2	5.4	E1
SECM264-E2.0 (A/B)	0.50	2.8	0.7	1.4	0.50	1.4	2.8	5.6	0.39	2.0	1.4	1.4	E2
SECM264-E3.0 (A/B)	0.50	4.2	0.3*	0.5	0.50	2.1	1.2*	2.0	0.39	3.0	0.6*	0.5	E2

Number of Leads	Weight of Motor	Size Length	Rotor Inertia
8	0.45 kg	56.4 x 56.4 x 39 mm	120 x 10 ⁻⁷ kgm ²

Resistance / Phase (Ω) = ± 10%, (* ± 15%), Inductance / Phase (mH) = ± 20%

Model A = Single Shaft B = Double Shaft	● Bipolar Parallel				● Bipolar Serial				● Unipolar				Torque Speed-curve
	Holding Torque [Nm]	Current/Phase [A]	Resistance/Phase [Ohm]	Inductance/Phase [mH]	Holding Torque [Nm]	Current/Phase [A]	Resistance/Phase [Ohm]	Inductance/Phase [mH]	Holding Torque [Nm]	Current/Phase [A]	Resistance/Phase [Ohm]	Inductance/Phase [mH]	
SECM266-E1.0 (A/B)	1.17	1.4	3.6	11.0	1.17	0.7	14.4	44.0	0.90	1.0	7.2	11.0	F1
SECM266-E2.0 (A/B)	1.17	2.8	0.9	2.5	1.17	1.4	3.6	10.0	0.90	2.0	1.8	2.5	F2
SECM266-E3.0 (A/B)	1.17	4.2	0.4*	1.2	1.17	2.1	1.6*	4.8	0.90	3.0	0.8*	1.2	F3

Number of Leads	Weight of Motor	Size Length	Rotor Inertia
8	0.7 kg	56.4 x 56.4 x 54 mm	260 x 10 ⁻⁷ kgm ²

Resistance / Phase (Ω) = ± 10%, (* ± 15%), Inductance / Phase (mH) = ± 20%

Model A = Single Shaft B = Double Shaft	● Bipolar Parallel				● Bipolar Serial				● Unipolar				Torque Speed-curve
	Holding Torque [Nm]	Current/Phase [A]	Resistance/Phase [Ohm]	Inductance/Phase [mH]	Holding Torque [Nm]	Current/Phase [A]	Resistance/Phase [Ohm]	Inductance/Phase [mH]	Holding Torque [Nm]	Current/Phase [A]	Resistance/Phase [Ohm]	Inductance/Phase [mH]	
SECM268-E1.0 (A/B)	1.75	1.4	4.1	14.0	1.75	0.7	16.4	56.0	1.35	1.0	8.2	14.0	G1
SECM268-E2.0 (A/B)	1.75	2.8	1.2	3.6	1.75	1.4	4.6	14.4	1.35	2.0	2.3	3.6	G2
SECM268-E2.3 (A/B)	1.75	3.3	0.9	2.8	1.75	1.65	3.4	11.2	1.35	2.3	1.7	2.8	G3
SECM268-E3.0 (A/B)	1.75	4.2	0.5*	1.6	1.75	2.1	2.0*	6.4	1.35	3.0	1.0*	1.6	G4

Number of Leads	Weight of Motor	Size Length	Rotor Inertia
8	1.0 kg	56.4 x 56.4 x 76 mm	430 x 10 ⁻⁷ kgm ²

Resistance / Phase (Ω) = ± 10%, (* ± 15%), Inductance / Phase (mH) = ± 20%

HECM / SECM - Series

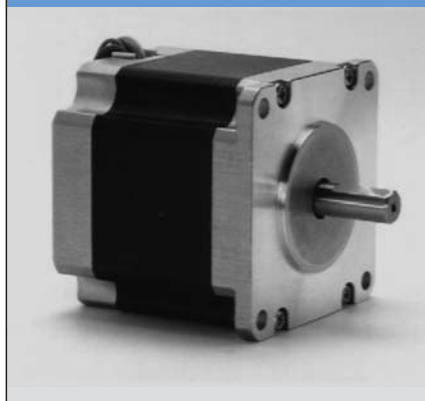

GENERAL SPECIFICATIONS

Items	Specifications
Shaft Runout	0.05 mm Max. T.I.R.
Shaft Radial Play	0.025 mm Max. (0.5 kg)
Shaft Axial Play	0.075 mm Max. (1 kg)
Insulation Resistance	100 M Ω (DC 500 V)
Dielectric Strength	500 V AC (1 Minute)
Insulation Class	CLASS B (130°)
Temperature Rise	80° C MAX. (2 PHASE ON)
Working Temperature	-20° C ~ + 50° C

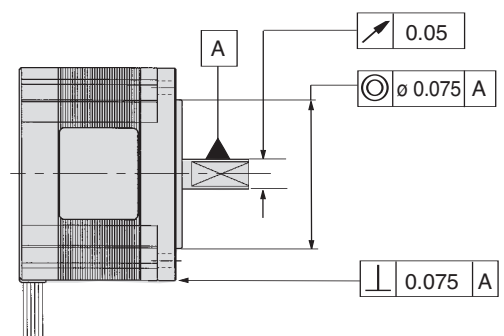

TORQUE VS. SPEED CHARACTERISTIC

Nm/KPPS (1000 PULSE/SECOND)

DIMENSIONS

UNIT = mm

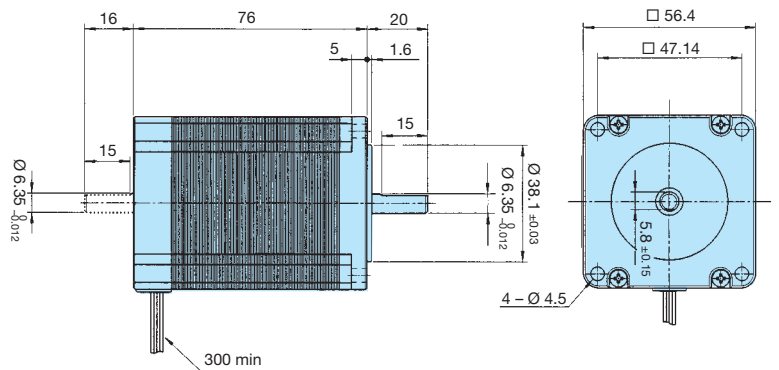
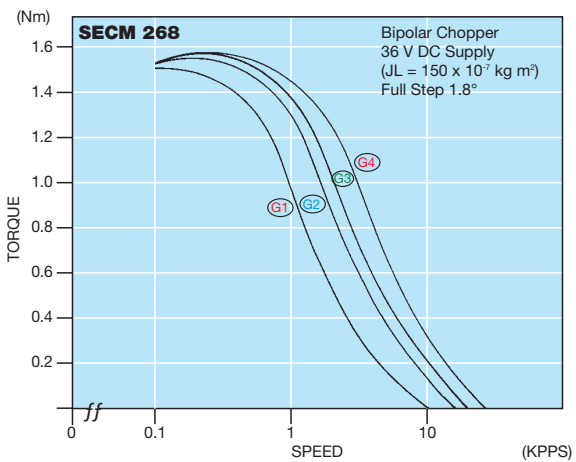
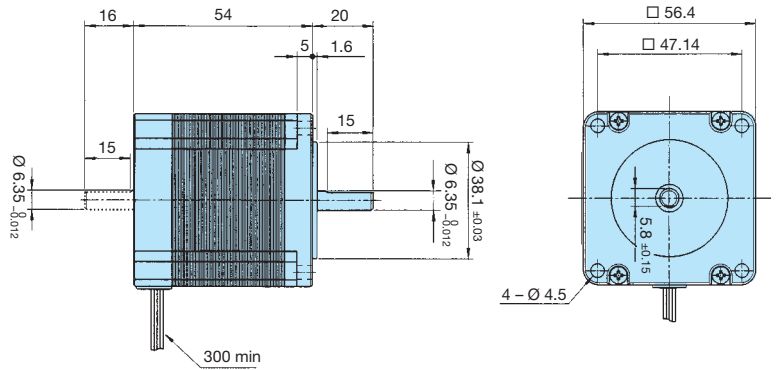
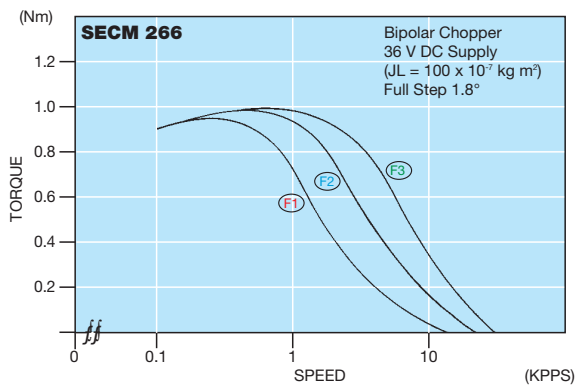
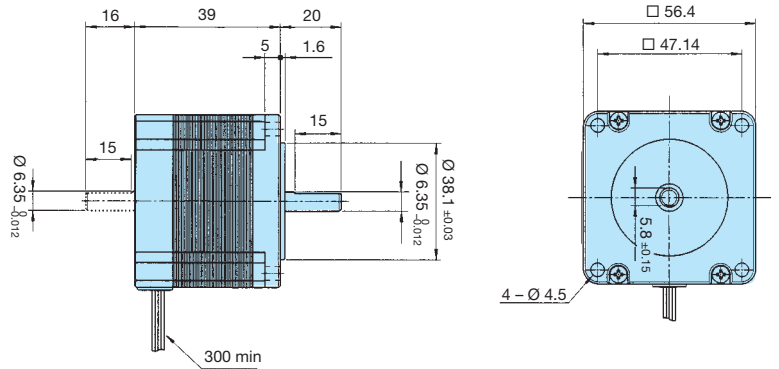
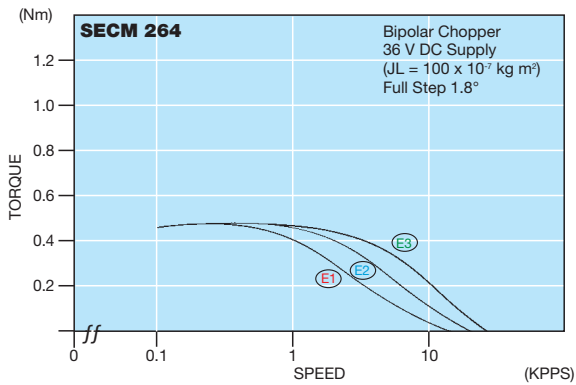

COLOR OF LEAD WIRES

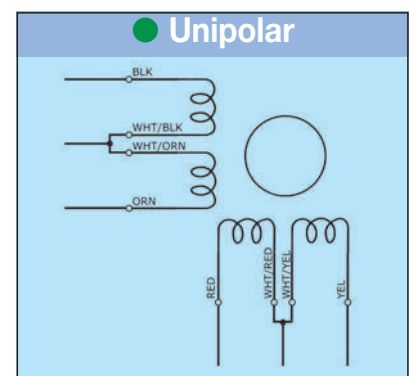
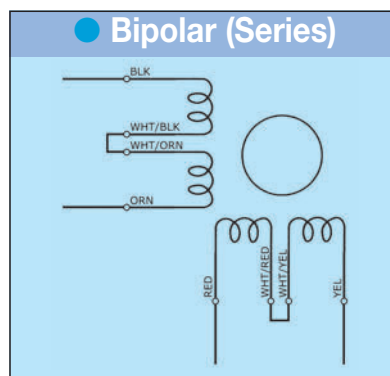
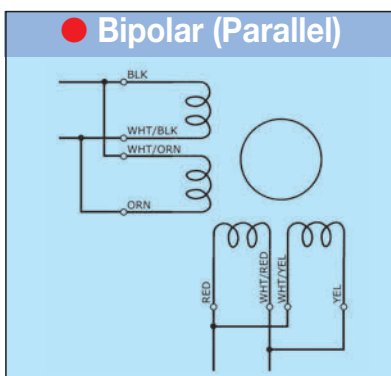

STEPPING MOTORS

□ 86 mm SECM-SPECIFICATIONS

1.8° HIGH-TORQUE 2 PHASE STEPPING MOTOR

Model AE = Single Shaft BE = Double Shaft	● Bipolar Parallel				● Bipolar Serial				● Unipolar				Torque Speed- curve
	Holding Torque [Nm]	Current/ Phase [A]	Resistance/ Phase [Ohm]	Inductance/ Phase [mH]	Holding Torque [Nm]	Current/ Phase [A]	Resistance/ Phase [Ohm]	Inductance/ Phase [mH]	Holding Torque [Nm]	Current/ Phase [A]	Resistance/ Phase [Ohm]	Inductance/ Phase [mH]	
SECM296-E4.5 (AE/BE)	3.70	6.4	0.2	1.6	3.70	3.2	0.8	6.4	2.75	4.5	0.4	1.6	(H1)

Number of Leads	Weight of Motor	Size Length	Rotor Inertia
8	2.1 kg	86 x 86 x 79 mm	1600 x 10 ⁻⁷ kgm ²

Resistance / Phase (Ω) = ± 15%, Inductance / Phase (mH) = ± 20%

Model AE = Single Shaft BE = Double Shaft	● Bipolar Parallel				● Bipolar Serial				● Unipolar				Torque Speed- curve
	Holding Torque [Nm]	Current/ Phase [A]	Resistance/ Phase [Ohm]	Inductance/ Phase [mH]	Holding Torque [Nm]	Current/ Phase [A]	Resistance/ Phase [Ohm]	Inductance/ Phase [mH]	Holding Torque [Nm]	Current/ Phase [A]	Resistance/ Phase [Ohm]	Inductance/ Phase [mH]	
SECM299-E4.5 (AE/BE)	7.30	6.4	0.3	3.1	7.30	3.2	1.2	12.4	5.40	4.5	0.6	3.1	(I1)
SECM299-E6.4 (AE/BE)	6.90	9.0	0.16*	1.1	6.90	4.5	0.64*	4.4	5.00	6.4	0.32*	1.1	(I2)

Number of Leads	Weight of Motor	Size Length	Rotor Inertia
8	3.5 kg	86 x 86 x 117.5 mm	3200 x 10 ⁻⁷ kgm ²

Resistance / Phase (Ω) = ± 15%, (* ± 20%), Inductance / Phase (mH) = ± 20%

Model AE = Single Shaft BE = Double Shaft	● Bipolar Parallel				● Bipolar Serial				● Unipolar				Torque Speed- curve
	Holding Torque [Nm]	Current/ Phase [A]	Resistance/ Phase [Ohm]	Inductance/ Phase [mH]	Holding Torque [Nm]	Current/ Phase [A]	Resistance/ Phase [Ohm]	Inductance/ Phase [mH]	Holding Torque [Nm]	Current/ Phase [A]	Resistance/ Phase [Ohm]	Inductance/ Phase [mH]	
SECM2913-E4.0 (AE/BE)	10.20	5.7	0.43	4.6	10.20	2.8	1.7	18.4	7.40	4.0	0.85	4.6	(J1)
SECM2913-E6.4 (AE/BE)	9.80	9.0	0.19*	1.7	9.80	4.5	0.76*	6.8	7.20	6.4	0.38*	1.7	(J2)

Number of Leads	Weight of Motor	Size Length	Rotor Inertia
8	5.0 kg	86 x 86 x 156 mm	4800 x 10 ⁻⁷ kgm ²

Resistance / Phase (Ω) = ± 15%, (* ± 20%), Inductance / Phase (mH) = ± 20%

SECM29... - Series



GENERAL SPECIFICATIONS

Items	Specifications
Shaft Runout	0.05 mm Max. T.I.R.
Shaft Radial Play	0.025 mm Max. (0.5 kg)
Shaft Axial Play	0.075 mm Max. (1 kg)
Insulation Resistance	100 M Ω (DC 500 V)
Dielectric Strength	500 V AC (1 Minute)
Insulation Class	CLASS B (130°)
Temperature Rise	80° C MAX. (2 PHASE ON)
Working Temperature	-20° C ~ +50° C

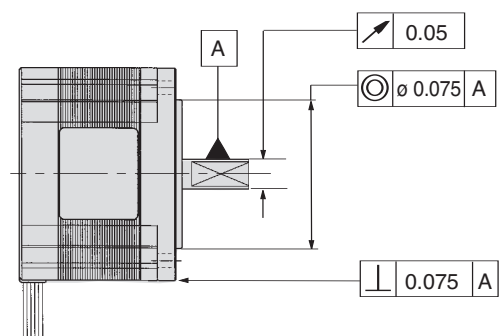

TORQUE VS. SPEED CHARACTERISTIC

Nm/KPPS (1000 PULSE/SECOND)

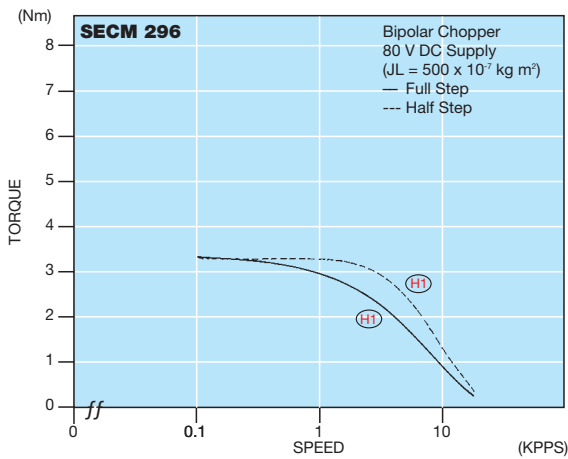

DIMENSIONS

UNIT = mm

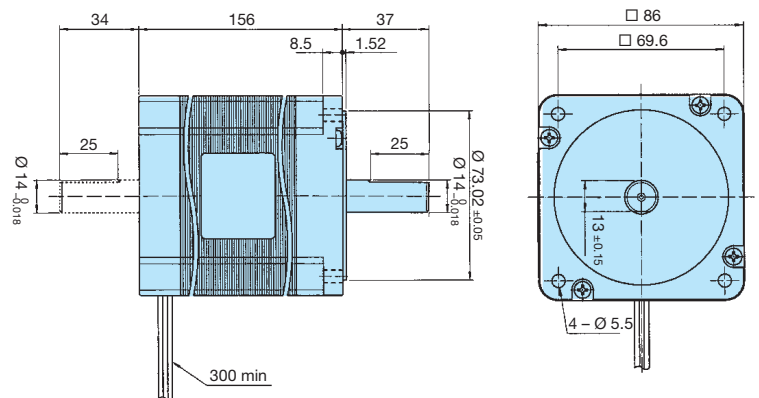
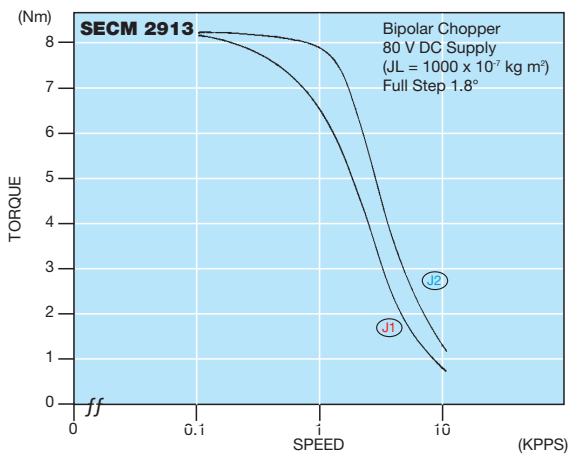
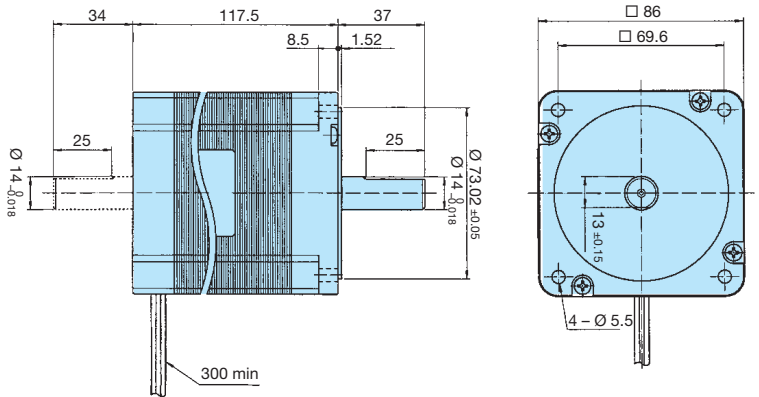
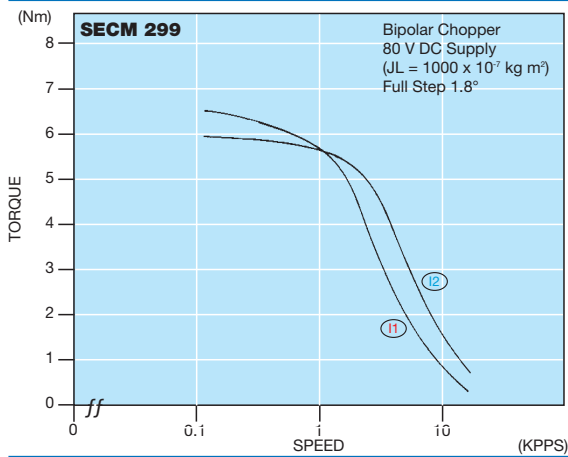
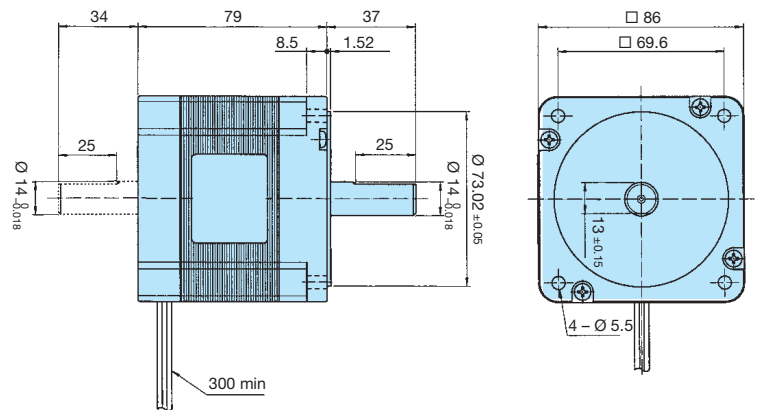

COLOR OF LEAD WIRES

● Bipolar (Parallel)

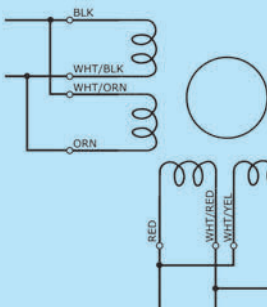

● Bipolar (Series)

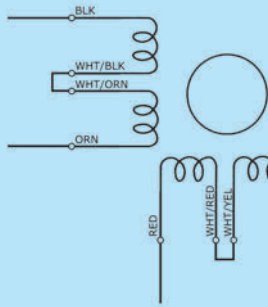

● Unipolar

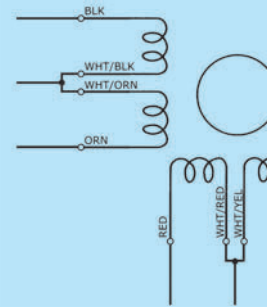

STEPPING MOTORS

□ 86 mm SECM-SPECIFICATIONS

1.8° HIGH-TORQUE 2 PHASE STEPPING MOTOR WITH TERMINAL BOX

Model AE = Single Shaft T = Terminal Box	● Bipolar Parallel				● Bipolar Serial				● Unipolar				Torque Speed-curve
	Holding Torque [Nm]	Current/Phase [A]	Resistance/Phase [Ohm]	Inductance/Phase [mH]	Holding Torque [Nm]	Current/Phase [A]	Resistance/Phase [Ohm]	Inductance/Phase [mH]	Holding Torque [Nm]	Current/Phase [A]	Resistance/Phase [Ohm]	Inductance/Phase [mH]	
SECM296-E4.5AE-T	3.70	6.4	0.2	1.6	3.70	3.2	0.8	6.4	2.75	4.5	0.4	1.6	(K1)

Number of Leads (Terminal Box)	Weight of Motor	Size Length	Rotor Inertia
8	2.5 kg	86 x 86 x 112.5 mm	1600 x 10 ⁻⁷ kgm ²

Resistance / Phase (Ω) = ± 15%, Inductance / Phase (mH) = ± 20%

Model AE = Single Shaft T = Terminal Box	● Bipolar Parallel				● Bipolar Serial				● Unipolar				Torque Speed-curve
	Holding Torque [Nm]	Current/Phase [A]	Resistance/Phase [Ohm]	Inductance/Phase [mH]	Holding Torque [Nm]	Current/Phase [A]	Resistance/Phase [Ohm]	Inductance/Phase [mH]	Holding Torque [Nm]	Current/Phase [A]	Resistance/Phase [Ohm]	Inductance/Phase [mH]	
SECM299-E4.5AE-T	7.30	6.4	0.3	3.1	7.30	3.2	1.2	12.4	5.40	4.5	0.6	3.1	(L1)
SECM299-E6.4AE-T	6.90	9.0	0.16*	1.1	6.90	4.5	0.64*	4.4	5.00	6.4	0.32*	1.1	(L2)

Number of Leads (Terminal Box)	Weight of Motor	Size Length	Rotor Inertia
8	3.9 kg	86 x 86 x 151 mm	3200 x 10 ⁻⁷ kgm ²

Resistance / Phase (Ω) = ± 15%, (* ± 20%), Inductance / Phase (mH) = ± 20%

Model AE = Single Shaft T = Terminal Box	● Bipolar Parallel				● Bipolar Serial				● Unipolar				Torque Speed-curve
	Holding Torque [Nm]	Current/Phase [A]	Resistance/Phase [Ohm]	Inductance/Phase [mH]	Holding Torque [Nm]	Current/Phase [A]	Resistance/Phase [Ohm]	Inductance/Phase [mH]	Holding Torque [Nm]	Current/Phase [A]	Resistance/Phase [Ohm]	Inductance/Phase [mH]	
SECM2913-E4.0AE-T	10.20	5.7	0.43	4.6	10.20	2.8	1.7	18.4	7.40	4.0	0.85	4.6	(M1)
SECM2913-E6.4AE-T	9.80	9.0	0.19*	1.7	9.80	4.5	0.76*	6.8	7.20	6.4	0.38*	1.7	(M2)

Number of Leads (Terminal Box)	Weight of Motor	Size Length	Rotor Inertia
8	5.4 kg	86 x 86 x 189.5 mm	4800 x 10 ⁻⁷ kgm ²

Resistance / Phase (Ω) = ± 15%, (* ± 20%), Inductance / Phase (mH) = ± 20%

SECM29... - Terminal Box

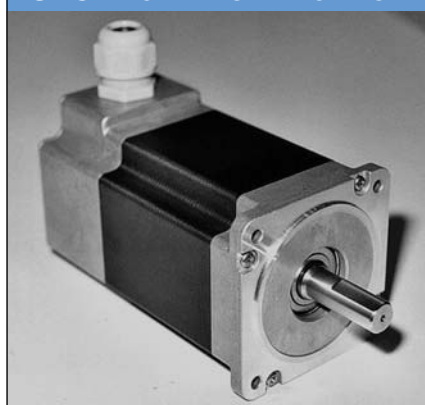

Terminal Box - Motor Connection (figure = Bipolar Parallel)

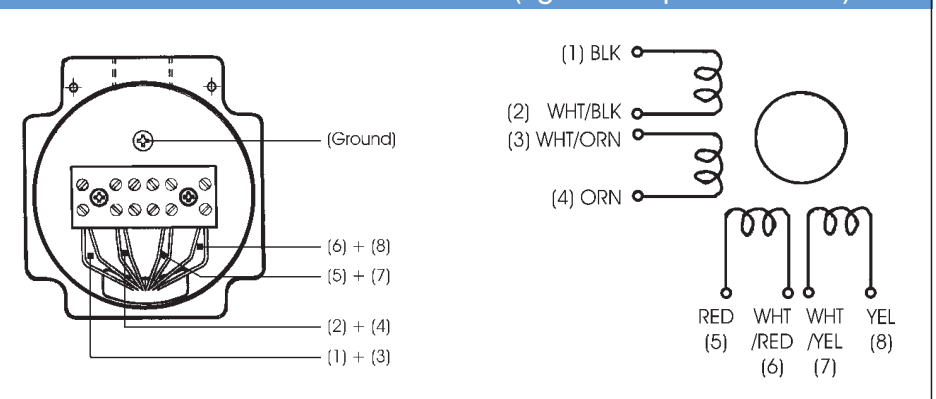

TORQUE VS. SPEED CHARACTERISTIC

Nm/KPPS (1000 PULSE/SECOND)

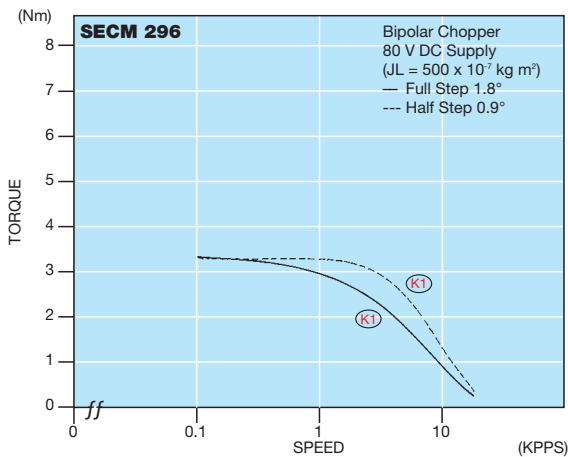

DIMENSIONS

UNIT = mm

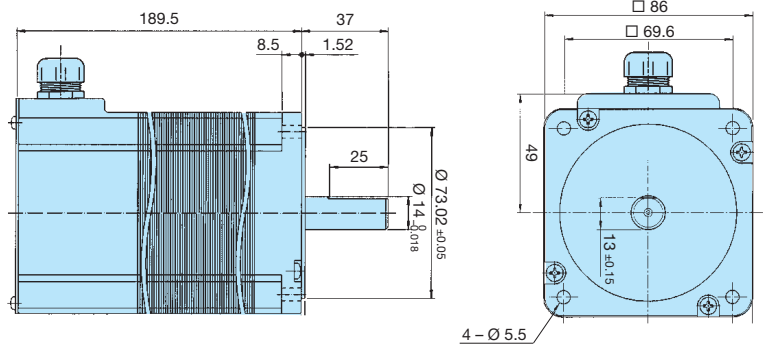
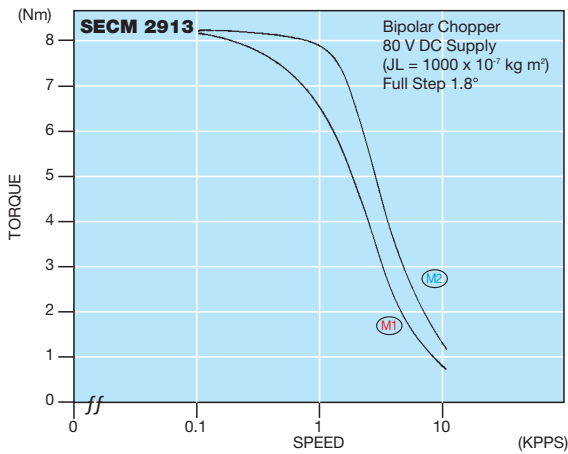
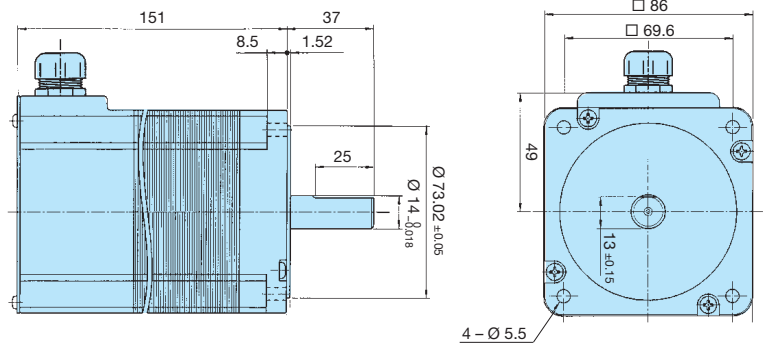
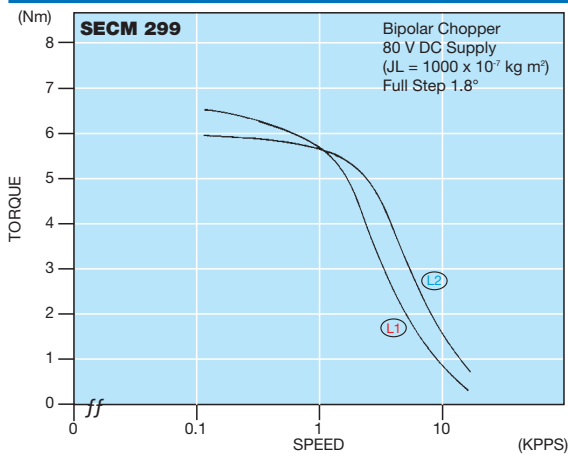
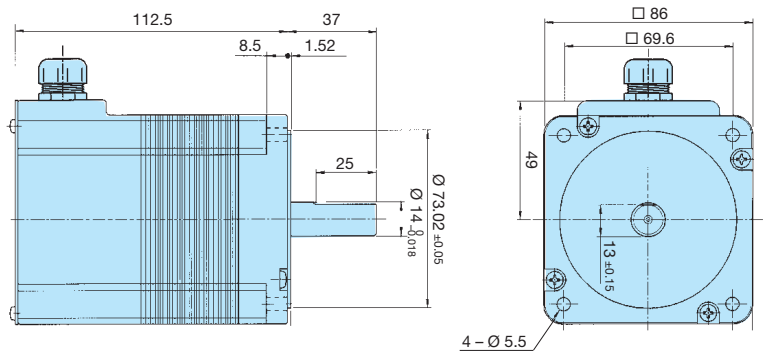

COLOR OF LEAD WIRES

● Bipolar (Parallel)

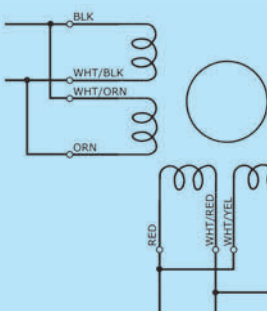

● Bipolar (Series)

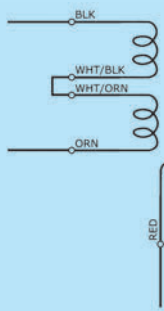

● Unipolar

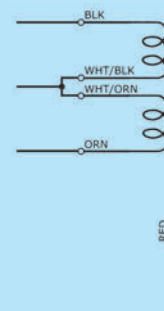

STEPPING MOTORS

□ 56.4 mm SECM-SPECIFICATIONS

0.9° HIGH-TORQUE 2 PHASE STEPPING MOTOR

Model A = Single Shaft B = Double Shaft	● Bipolar Parallel				● Bipolar Serial				● Unipolar				Torque Speed-curve
	Holding Torque [Nm]	Current/Phase [A]	Resistance/Phase [Ohm]	Inductance/Phase [mH]	Holding Torque [Nm]	Current/Phase [A]	Resistance/Phase [Ohm]	Inductance/Phase [mH]	Holding Torque [Nm]	Current/Phase [A]	Resistance/Phase [Ohm]	Inductance/Phase [mH]	
SECM264M-E1.0 (A/B)	0.55	1.4	2.8	8.4	0.55	0.7	11.2	33.6	0.44	1.0	5.6	8.4	(N1)
SECM264M-E2.0 (A/B)	0.55	2.8	0.7	2.2	0.55	1.4	2.8	8.8	0.44	2.0	1.4	2.2	(N2)
SECM264M-E3.0 (A/B)	0.55	4.2	0.3*	0.9	0.55	2.1	1.2*	3.6	0.44	3.0	0.6*	0.9	(N3)

Number of Leads	Weight of Motor	Size Length	Rotor Inertia
8	0.45 kg	56.4 x 56.4 x 39 mm	145 x 10 ⁻⁷ kgm ²

Resistance / Phase (Ω) = ± 10%, (* ± 15%), Inductance / Phase (mH) = ± 20%

Model A = Single Shaft B = Double Shaft	● Bipolar Parallel				● Bipolar Serial				● Unipolar				Torque Speed-curve
	Holding Torque [Nm]	Current/Phase [A]	Resistance/Phase [Ohm]	Inductance/Phase [mH]	Holding Torque [Nm]	Current/Phase [A]	Resistance/Phase [Ohm]	Inductance/Phase [mH]	Holding Torque [Nm]	Current/Phase [A]	Resistance/Phase [Ohm]	Inductance/Phase [mH]	
SECM266M-E1.0 (A/B)	1.25	1.4	3.6	23.1	1.25	0.7	14.4	92.4	0.95	1.0	7.2	23.1	(O1)
SECM266M-E2.0 (A/B)	1.25	2.8	0.9	5.9	1.25	1.4	3.6	23.6	0.95	2.0	1.8	5.9	(O2)
SECM266M-E3.0 (A/B)	1.25	4.2	0.4*	2.6	1.25	2.1	1.6*	10.4	0.95	3.0	0.8*	2.6	(O3)

Number of Leads	Weight of Motor	Size Length	Rotor Inertia
8	0.7 kg	56.4 x 56.4 x 54 mm	310 x 10 ⁻⁷ kgm ²

Resistance / Phase (Ω) = ± 10%, (* ± 15%), Inductance / Phase (mH) = ± 20%

Model A = Single Shaft B = Double Shaft	● Bipolar Parallel				● Bipolar Serial				● Unipolar				Torque Speed-curve
	Holding Torque [Nm]	Current/Phase [A]	Resistance/Phase [Ohm]	Inductance/Phase [mH]	Holding Torque [Nm]	Current/Phase [A]	Resistance/Phase [Ohm]	Inductance/Phase [mH]	Holding Torque [Nm]	Current/Phase [A]	Resistance/Phase [Ohm]	Inductance/Phase [mH]	
SECM268M-E2.0 (A/B)	1.95	2.8	1.15	7.8	1.95	1.4	4.6	31.2	1.45	2.0	2.3	7.8	(P1)
SECM268M-E2.4 (A/B)	1.95	3.5	0.75	5.0	1.95	1.75	3.0	20.0	1.45	2.45	1.5	5.0	(P2)
SECM268M-E3.0 (A/B)	1.95	4.2	0.5*	3.5	1.95	2.1	2.0*	14.0	1.45	3.0	1.0*	3.5	(P3)

Number of Leads	Weight of Motor	Size Length	Rotor Inertia
8	1.0 kg	56.4 x 56.4 x 76 mm	520 x 10 ⁻⁷ kgm ²

Resistance / Phase (Ω) = ± 10%, (* ± 15%), Inductance / Phase (mH) = ± 20%

SECM 26... Series 0.9°

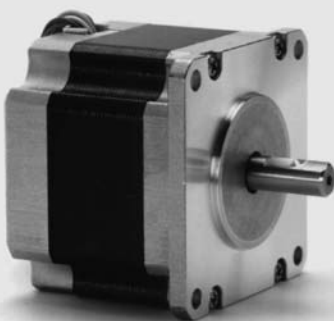

GENERAL SPECIFICATIONS

Items	Specifications
Shaft Runout	0.05 mm Max. T.I.R.
Shaft Radial Play	0.025 mm Max. (0.5 kg)
Shaft Axial Play	0.075 mm Max. (1 kg)
Insulation Resistance	100 M Ω (DC 500 V)
Dielectric Strength	500 V AC (1 Minute)
Insulation Class	CLASS B (130°)
Temperature Rise	80° C MAX. (2 PHASE ON)
Working Temperature	-20° C ~ + 50° C

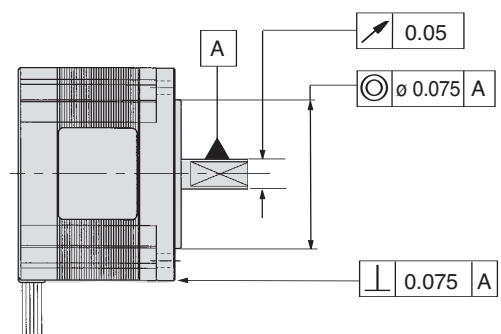

TORQUE VS. SPEED CHARACTERISTIC

Nm/KPPS (1000 PULSE/SECOND)

DIMENSIONS

UNIT = mm

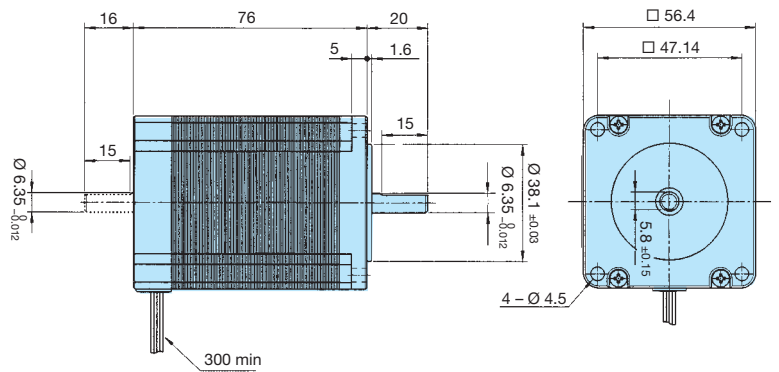
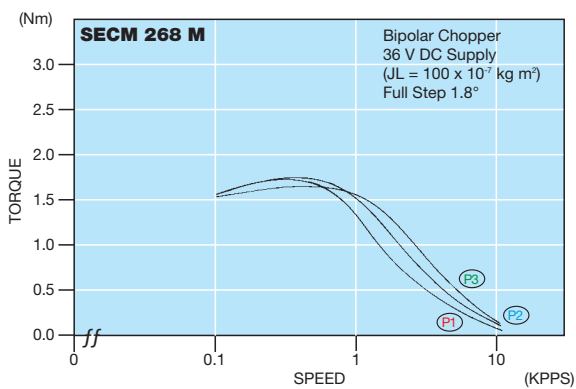
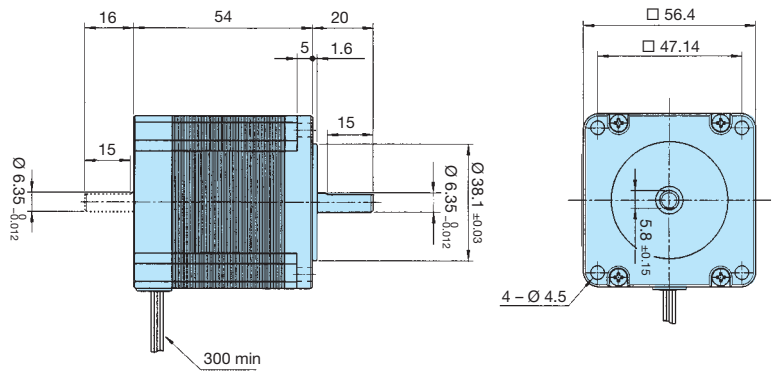
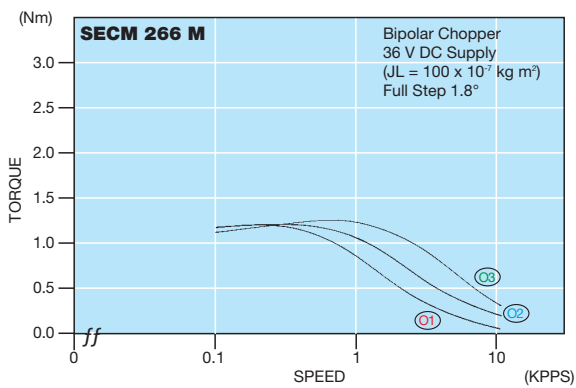
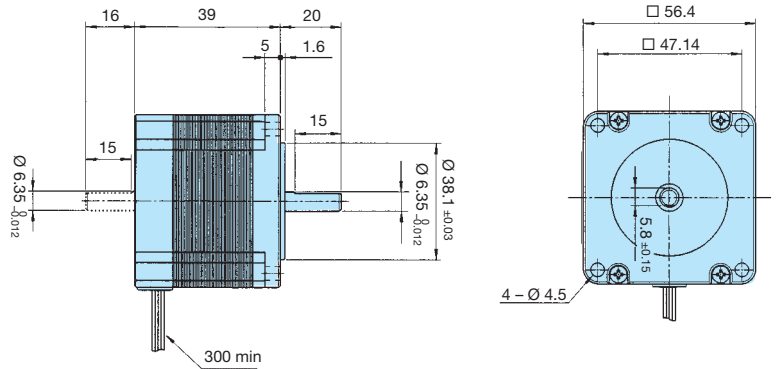
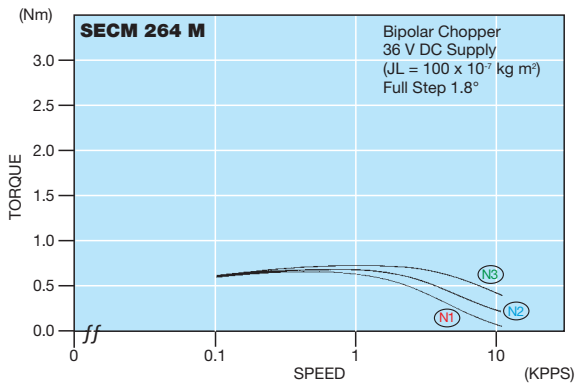

COLOR OF LEAD WIRES

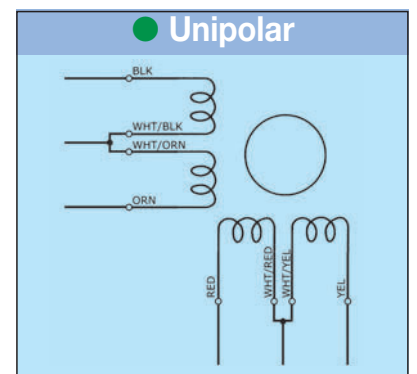
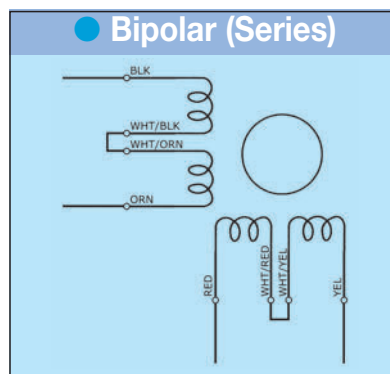
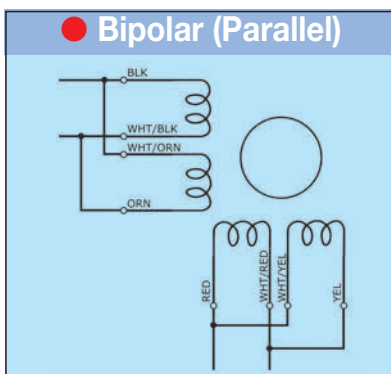

STEPPING MOTORS

□ 56.4 mm ECM-SPECIFICATIONS

1.8° 2 PHASE STEPPING MOTOR

Model A = Single Shaft B = Double Shaft	● Bipolar Parallel				● Bipolar Serial				● Unipolar				Torque Speed-curve
	Holding Torque [Nm]	Current/Phase [A]	Resistance/Phase [Ohm]	Inductance/Phase [mH]	Holding Torque [Nm]	Current/Phase [A]	Resistance/Phase [Ohm]	Inductance/Phase [mH]	Holding Torque [Nm]	Current/Phase [A]	Resistance/Phase [Ohm]	Inductance/Phase [mH]	
ECM264-E1.5 (A/B)	0.40	2.1	0.75	1.8	0.40	1.05	3.0	7.2	0.29	1.5	1.5	1.8	Q1
ECM265-E1.0 (A/B)	0.70	1.4	2.5	9.0	0.70	0.7	10.0	36.0	0.50	1.0	5.0	9.0	Q2
ECM265-E2.6 (A/B)	0.60	3.7	0.36	0.9	0.60	1.85	1.44	3.6	0.45	2.6	0.72	0.9	Q3
ECM266-E1.2 (A/B)	0.80	1.7	2.5	9.0	0.80	0.85	10.0	36.0	0.60	1.2	5.0	9.0	Q4

Number of Leads	Weight of Motor	Size Length	Rotor Inertia
8	0.4 kg	ECM264... 56.4 x 56.4 x 38 mm	57 x 10 ⁻⁷ kgm ²
8	0.55 kg	ECM265... 56.4 x 56.4 x 51 mm	100 x 10 ⁻⁷ kgm ²
8	0.6 kg	ECM266... 56.4 x 56.4 x 51 mm	100 x 10 ⁻⁷ kgm ²

Resistance / Phase (Ω) = ± 10%, Inductance / Phase (mH) = ± 20%

Model A = Single Shaft B = Double Shaft	● Bipolar Parallel				● Bipolar Serial				● Unipolar				Torque Speed-curve
	Holding Torque [Nm]	Current/Phase [A]	Resistance/Phase [Ohm]	Inductance/Phase [mH]	Holding Torque [Nm]	Current/Phase [A]	Resistance/Phase [Ohm]	Inductance/Phase [mH]	Holding Torque [Nm]	Current/Phase [A]	Resistance/Phase [Ohm]	Inductance/Phase [mH]	
ECM268-E1.6 (A/B)	1.25	2.3	1.6	5.5	1.25	1.15	6.4	22.0	0.95	1.6	3.2	5.5	R1
ECM268-E2.3 (A/B)	1.25	3.3	0.85	3.5	1.25	1.65	3.4	14.0	0.95	2.3	1.7	3.5	R2

Number of Leads	Weight of Motor	Size Length	Rotor Inertia
8	1.0 kg	56.4 x 56.4 x 76 mm	234 x 10 ⁻⁷ kgm ²

Resistance / Phase (Ω) = ± 10%, Inductance / Phase (mH) = ± 20%

Model A = Single Shaft B = Double Shaft	● Bipolar Parallel				● Bipolar Serial				● Unipolar				Torque Speed-curve
	Holding Torque [Nm]	Current/Phase [A]	Resistance/Phase [Ohm]	Inductance/Phase [mH]	Holding Torque [Nm]	Current/Phase [A]	Resistance/Phase [Ohm]	Inductance/Phase [mH]	Holding Torque [Nm]	Current/Phase [A]	Resistance/Phase [Ohm]	Inductance/Phase [mH]	
ECM2610-E2.9 (A/B)	1.65	4.1	0.6	2.2	1.65	2.05	2.4	8.8	1.25	2.9	1.2	2.2	S1

Number of Leads	Weight of Motor	Size Length	Rotor Inertia
8	1.2 kg	56.4 x 56.4 x 101.6 mm	322 x 10 ⁻⁷ kgm ²

Resistance / Phase (Ω) = ± 10%, Inductance / Phase (mH) = ± 20%

ECM 26... Series



GENERAL SPECIFICATIONS

Items	Specifications
Shaft Runout	0.05 mm Max. T.I.R.
Shaft Radial Play	0.03 mm Max. (0.45 kg)
Shaft Axial Play	0.13 mm Max. (0.45 kg)
Insulation Resistance	100 M Ω (DC 500 V)
Dielectric Strength	500 V AC (1 Minute)
Insulation Class	CLASS B (130°)
Temperature Rise	80° C MAX. (2 PHASE ON)
Working Temperature	-20° C ~ + 50° C

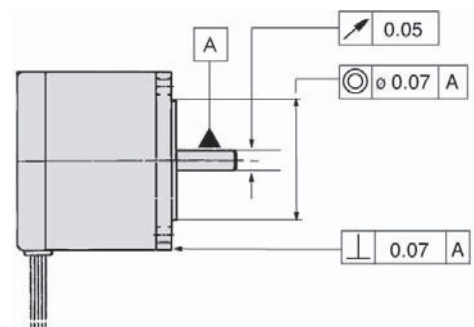

TORQUE VS. SPEED CHARACTERISTIC

Nm/KPPS (1000 PULSE/SECOND)

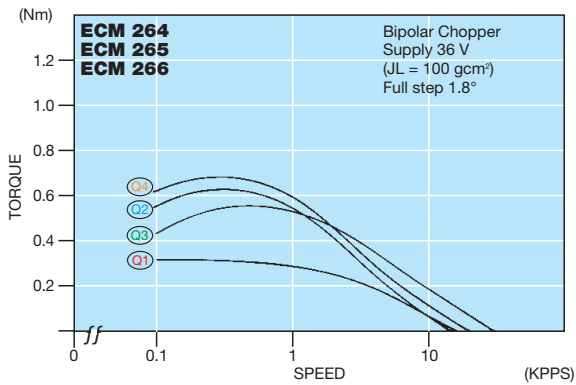

DIMENSIONS

UNIT = mm

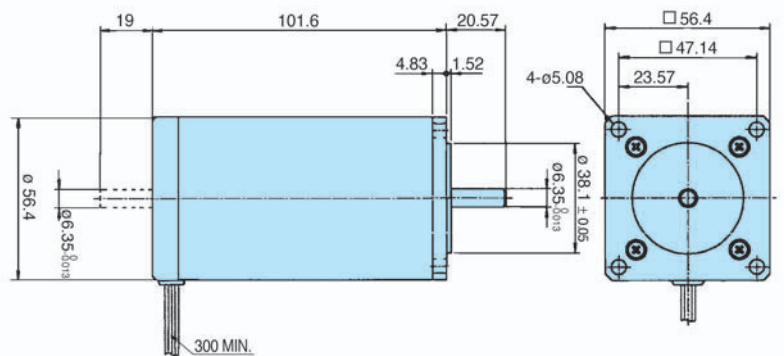
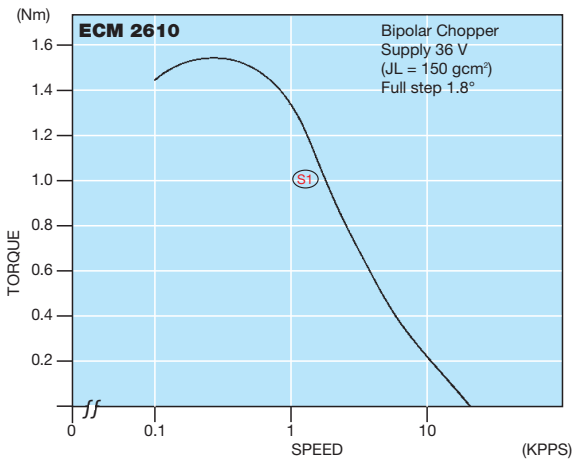
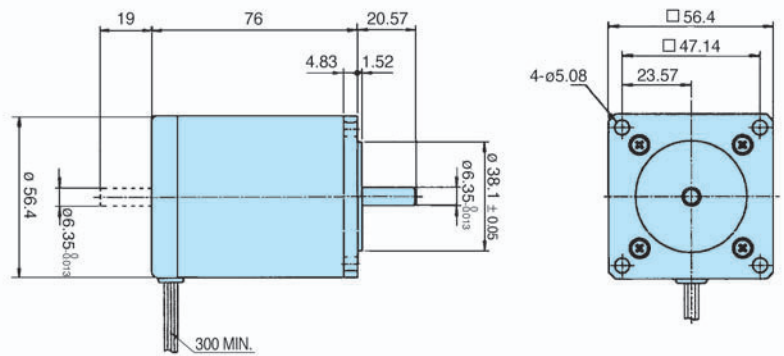
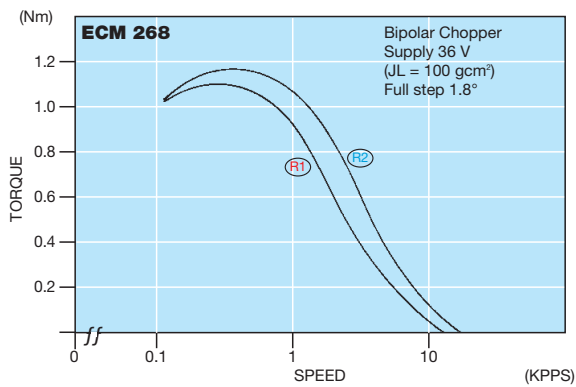
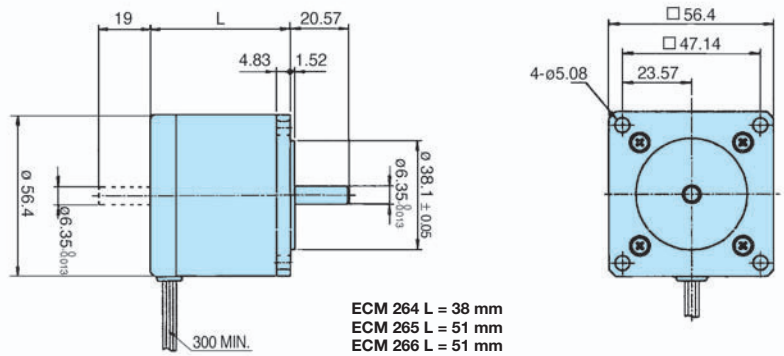

COLOR OF LEAD WIRES

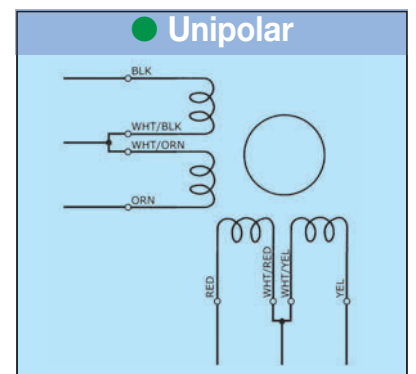
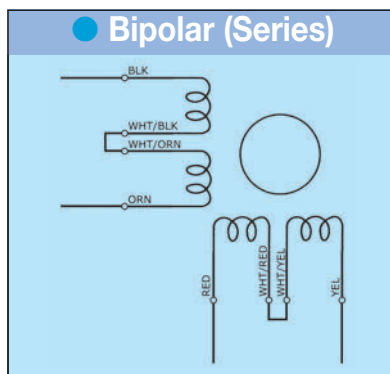
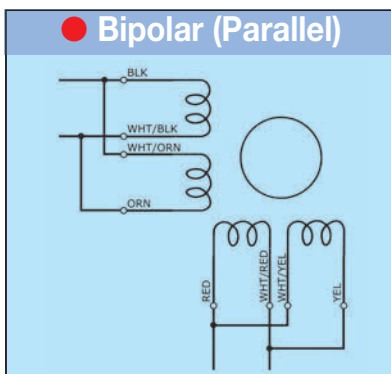

STEPPING MOTORS

□ 56.4 mm ENCODER-SPECIFICATIONS

1.8° 2 PHASE STEPPING MOTOR

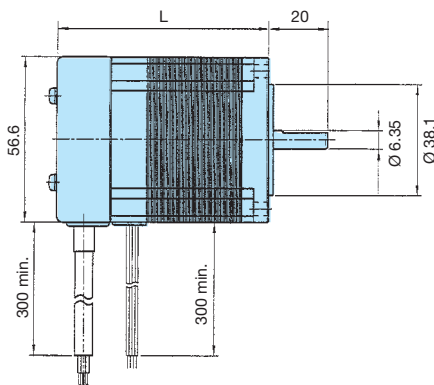

SECM264-E2.0P2200	L = 60 mm	Line Driver Output 200 CPR
SECM266-E2.0P2200	L = 75 mm	Line Driver Output 200 CPR
SECM268-E2.3P2200	L = 97 mm	Line Driver Output 200 CPR

For Motor Specification and Torque-Curve see following Pages:

SECM264-E2.0P2200 see spec. of SECM264-E2.0B → Page 6 and Page 7

SECM266-E2.0P2200 see spec. of SECM266-E2.0B → Page 6 and Page 7

SECM268-E2.3P2200 see spec. of SECM268-E2.3B → Page 6 and Page 7

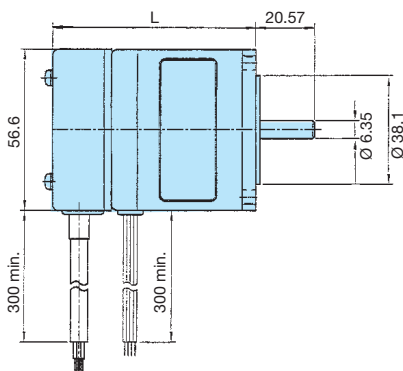

ECM264-E1.5P2200	L = 62 mm	Line Driver Output 200 CPR
ECM265-E1.0P2200	L = 74 mm	Line Driver Output 200 CPR
ECM265-E2.6P2200	L = 74 mm	Line Driver Output 200 CPR
ECM266-E1.2P2200	L = 74 mm	Line Driver Output 200 CPR
ECM268-E2.3P2200	L = 99 mm	Line Driver Output 200 CPR
ECM2610-E2.9P2200	L = 125 mm	Line Driver Output 200 CPR

For Motor Specification and Torque-Curve see following Pages:

ECM264-E1.5P2200 see spec. of ECM264-E1.5B → Page 14 and Page 15

ECM265-E1.0P2200 see spec. of ECM265-E1.0B → Page 14 and Page 15

ECM265-E2.6P2200 see spec. of ECM265-E2.6B → Page 14 and Page 15

ECM266-E1.2P2200 see spec. of ECM266-E1.2B → Page 14 and Page 15

ECM268-E2.3P2200 see spec. of ECM268-E2.3B → Page 14 and Page 15

ECM2610-E2.9P2200 see spec. of ECM2610-E2.9B → Page 14 and Page 15

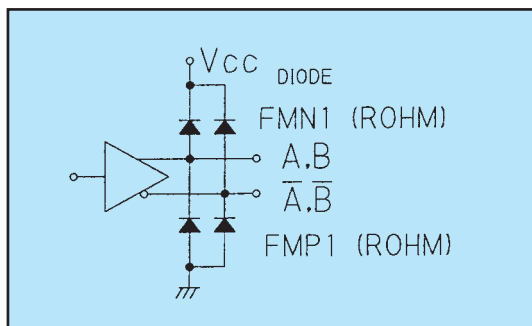

Encoder Performance (Line Driver Output):

Operating Temperature Range:	0°C up to 85°C
Supply:	DC 5V ± 5%, 100mA max.
Resolution:	200 Counts / Turn [CPR]
Frequency Response:	100KHz max.
A Phase Difference:	1/4 P ± 1/8 P
Code:	Incremental A. B. (2 CH.)
Output Signal when output is high:	DC 2.4V min.
Output Signal when output is low:	DC 0.4V max.
Sinking & Output Current:	Typical ± 20 mA max.
Rise & Fall Times:	1 µsec max.
Moment of Inertia:	5 g-cm² max. Encoder only
Output Circuit:	Line Driver AM26C3IIB

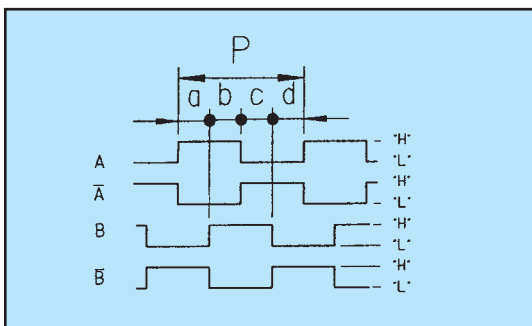

Encoder Connection Type A		Encoder Connection Type B	
Function	Color	Function	Color
DC 5 V	Red	DC 5 V	Red
GND	Blue	GND	Black
A Phase	Brown	A Phase	Brown
A-bar Phase	Orange	A-bar Phase	Orange
B Phase	Yellow	B Phase	Yellow
B-bar Phase	Gray	B-bar Phase	White

PLANETARY-GEAR PRODUCT

OVERVIEW

Model	Stages	Ratio (i)		max. Torque	for Step Motor	Size Page
		from	to			
● PLI40	1-stage / 1-stufig	3	7	3 Nm	HECM264...269	18 / 19
	2-stage / 2-stufig	14	46	7.5 Nm	SECM264...268	
	3-stage / 3-stufig	51	308	15 Nm	ECM264...2610	
● PLI50	1-stage / 1-stufig	3	7	4 Nm	HECM264...269	
	2-stage / 2-stufig	14	46	12 Nm	SECM264...268	
	3-stage / 3-stufig	51	308	25 Nm	ECM264...2610	
● PLI60	1-stage / 1-stufig	3	7	8 Nm	HECM264...269	
	2-stage / 2-stufig	14	46	25 Nm	SECM264...268	
	3-stage / 3-stufig	51	308	50 Nm	ECM264...2610	
● PLI80	1-stage / 1-stufig	3	7	20 Nm	SECM296...2913	
	2-stage / 2-stufig	14	46	60 Nm		
	3-stage / 3-stufig	51	308	120 Nm		
● PLD40	1-stage / 1-stufig	3	10	4.5 Nm	HECM264...269	20
	2-stage / 2-stufig	16	100	5 Nm	SECM264...268	
	3-stage / 3-stufig	120	1000	5 Nm	ECM264...2610	
● PLD60	1-stage / 1-stufig	3	10	16 Nm	HECM264...269	/ 21
	2-stage / 2-stufig	16	100	21 Nm	SECM264...268	
	3-stage / 3-stufig	120	1000	21 Nm	ECM264...2610	
● PLD80	1-stage / 1-stufig	3	10	45 Nm	SECM296...2913	
	2-stage / 2-stufig	16	100	58 Nm		
	3-stage / 3-stufig	120	1000	58 Nm		

PLANETARY GEAR PRODUCT NUMBER CODE:

PLI 40 3 26

for suitable Step Motor-Series: = HECM264-269 / SECM264-268, SECM296-2913 / ECM264-2610
für folgende Schrittmotorserien: = HECM264-269 / SECM264-268, SECM296-2913 / ECM264-2610

Number of Gear Ratio: = from $i = 3$ up to 1.000 *Untersetzung:* = von $i = 3$ bis 1.000

Gear-Size: = PLI 40 Ø approx. 4cm *Getriebe-* PLI 40 Ø ca. 4 cm
PLI 50 Ø approx. 5cm *durchmesser:* PLI 50 Ø ca. 5 cm
PLI 60 Ø approx. 6cm PLI 60 Ø ca. 6 cm
PLI 80 Ø approx. 8cm PLI 80 Ø ca. 8 cm
PLD40 Ø approx. 4cm PLD40 Ø ca. 4 cm
PLD60 Ø approx. 6cm PLD60 Ø ca. 6 cm
PLD80 Ø approx. 8cm PLD80 Ø ca. 8 cm

Planetary Gear Type: = PLI = non integer Gear Ratio PLD = integer Gear Ratio
Planetengetriebetyp: = PLI = kein ganzzahliges PLD = ganzzahliges
Untersetzungsverhältnis *Untersetzungsverhältnis*



PLANETARY GEARS

SPECIFICATIONS

Size / Baugröße		● PLI40	● PLI50	● PLI60	● PLI80	i	i ⁽¹⁾	z ⁽²⁾	Size Page
Nominal Output Torque T2N Abtriebs-Drehmoment T2N	[Nm]	3.0	4.0	8.0	20	(3.70)	3	1	19
		3.0	4.0	8.0	20	(4.28)	4		
		3.0	4.0	8.0	20	(5.18)	5		
		3.0	4.0	8.0	20	(6.75)	7		
		7.5	12	25	60	(13.73)	14	2	
		7.5	12	25	60	(15.88)	16		
		7.5	12	25	60	(18.36)	18		
		7.5	12	25	60	(19.20)	19		
		7.5	12	25	60	(22.20)	22		
		7.5	12	25	60	(25.01)	25		
		7.5	12	25	60	(26.85)	27		
		7.5	12	25	60	(28.93)	29		
		7.5	12	25	60	(34.97)	35	3	
		7.5	12	25	60	(45.56)	46		
		15	25	50	120	(50.89)	51		
		15	25	50	120	(58.85)	59		
		15	25	50	120	(68.06)	68		
		15	25	50	120	(71.16)	71		
		15	25	50	120	(78.71)	79		
		15	25	50	120	(92.70)	93		
		15	25	50	120	(95.17)	95		
		15	25	50	120	(99.50)	100		
		15	25	50	120	(107.20)	107		
		15	25	50	120	(115.07)	115		
		15	25	50	120	(123.97)	124		
		15	25	50	120	(129.62)	130		
		15	25	50	120	(139.13)	139		
		15	25	50	120	(149.90)	150		
		15	25	50	120	(168.84)	169		
		15	25	50	120	(181.24)	181		
		15	25	50	120	(195.26)	195		
		15	25	50	120	(236.09)	236		
		15	25	50	120	(307.54)	308		

Size / Baugröße		● PLI40	● PLI50	● PLI60	● PLI80	
efficiency / Wirkungsgrad		0.80	0.80	0.80	0.80	1-stage / 1-stufig
		0.75	0.75	0.75	0.75	2-stage / 2-stufig
		0.70	0.70	0.70	0.70	3-stage / 3-stufig
weight / Gewicht	[kg]	0.4	0.7	0.8	1.8	1-stage / 1-stufig
		0.5	0.9	1.2	2.5	2-stage / 2-stufig
		0.6	1.1	1.6	3.2	3-stage / 3-stufig
max. radial load / max. Radialkraft	[N]	160	200	240	400	1-stage / 1-stufig
max. axial load / max. Axialkraft	[N]	50	60	70	80	
max. radial load / max. Radialkraft	[N]	230	320	360	600	2-stage / 2-stufig
max. axial load / max. Axialkraft	[N]	80	100	100	120	
max. radial load / max. Radialkraft	[N]	300	450	520	1000	3-stage / 3-stufig
max. axial load / max. Axialkraft	[N]	110	150	150	200	
backlash / Verdrehspiel	[deg]	0.90°	0.70°	0.65°	0.50°	1-stage / 1-stufig
		0.95°	0.75°	0.70°	0.55°	2-stage / 2-stufig
		1.00°	0.80°	0.75°	0.60°	3-stage / 3-stufig
initial speed / Eingangsdrehzahl		3000 min ⁻¹				
operating temp. / Betriebstemp.	[°C]	-30 up to +140 / -30 bis +140				
lubrication / Schmierung		life time grease lubrication / Lebensdauer-Fettschmierung				

(1) = Ratios Rounded (1) = Übersetzungen gerundet

(2) = Number of Stages (2) = Anzahl der Getriebestufen

DIMENSIONS

UNIT = mm

● PLI 40 (for HECM26.../SECM26.../ECM26...)

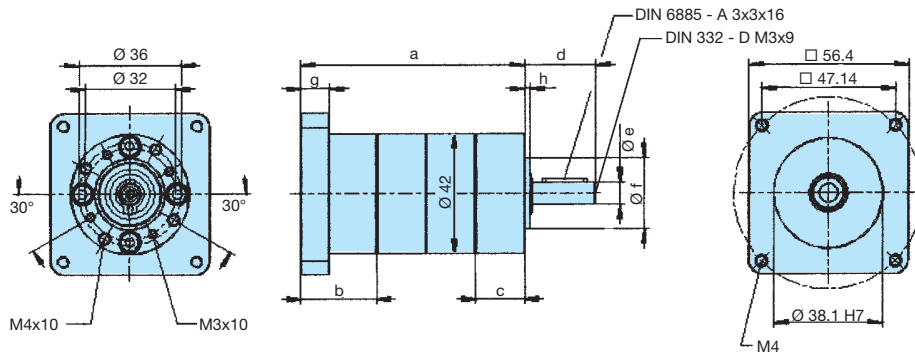

for SECM and ECM Stepping Motor

a = 65.5 mm (1-stage / 1-stufig)
 a = 78.5 mm (2-stage / 2-stufig)
 a = 91.5 mm (3-stage / 3-stufig)
 b = 26.5 mm e = 8 h 7
 c = 17.1 mm f = 25 h 9
 d = 25.0 mm h = 2 mm, g = 10 mm

for HECM Stepping Motor

a = 69.5 mm (1-stage / 1-stufig)
 a = 82.5 mm (2-stage / 2-stufig)
 a = 95.5 mm (3-stage / 3-stufig)
 b = 30.5 mm e = 8 h 7
 c = 17.1 mm f = 25 h 9
 d = 25.0 mm h = 2 mm, g = 10 mm

● PLI 50 (for HECM26.../SECM26.../ECM26...)

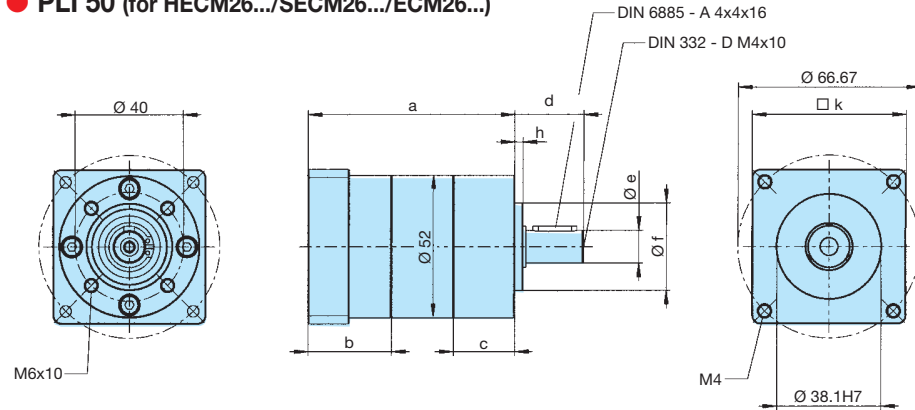

for SECM and ECM Stepping Motor

a = 75.5 mm (1-stage / 1-stufig)
 a = 89.5 mm (2-stage / 2-stufig)
 a = 103.6 mm (3-stage / 3-stufig)
 b = 30.3 mm e = 12 h 7
 c = 22.3 mm f = 32 h 8
 d = 25.0 mm h = 3 mm
 k = □ 56.4 mm

for HECM Stepping Motor

a = 77.6 mm (1-stage / 1-stufig)
 a = 91.7 mm (2-stage / 2-stufig)
 a = 105.8 mm (3-stage / 3-stufig)
 b = 32.5 mm e = 12 h 7
 c = 22.3 mm f = 32 h 8
 d = 25.0 mm h = 3 mm
 k = □ 60 mm

● PLI 60 (for HECM26.../SECM26.../ECM26...)

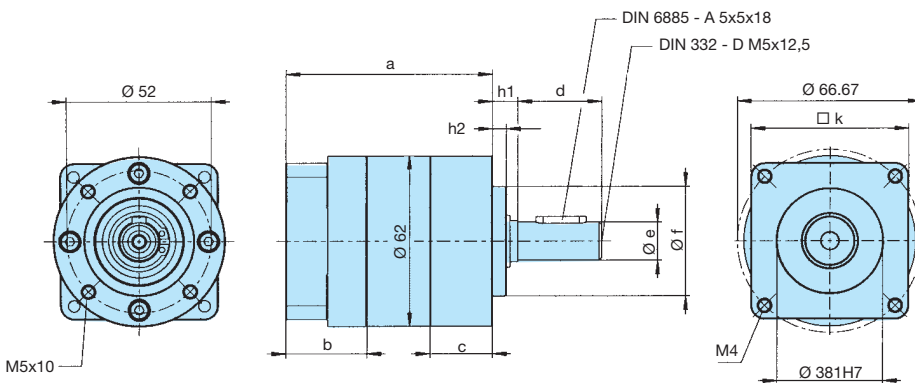

for SECM and ECM Stepping Motor

a = 74.2 mm (1-stage / 1-stufig)
 a = 90.0 mm (2-stage / 2-stufig)
 a = 105.9 mm (3-stage / 3-stufig)
 b = 29.1 mm e = 14 h 7
 c = 22.3 mm f = 40 j 7
 d = 30.0 mm h1 = 9 mm, h2 = 5 mm
 k = □ 57 mm

for HECM Stepping Motor

a = 78.2 mm (1-stage / 1-stufig)
 a = 94.0 mm (2-stage / 2-stufig)
 a = 109.9 mm (3-stage / 3-stufig)
 b = 33.1 mm e = 14 h 7
 c = 23.3 mm f = 40 j 7
 d = 30.0 mm h1 = 9 mm, h2 = 5 mm
 k = □ 60 mm

● PLI 80 (for SECM29...)

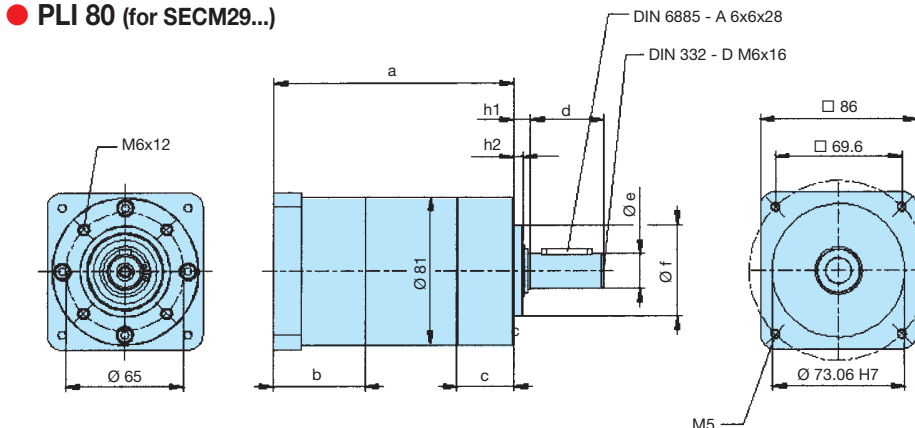

for SECM Stepping Motor

a = 109.6 mm (1-stage / 1-stufig)
 a = 131.3 mm (2-stage / 2-stufig)
 a = 152.9 mm (3-stage / 3-stufig)
 b = 50.0 mm e = 19 h 7
 c = 31.0 mm f = 50 j 7
 d = 40.0 mm h1 = 9 mm, h2 = 5 mm

for HECM Stepping Motor

please ask for detail drawing
 a = 96.6 mm (1-stage / 1-stufig)
 a = 118.3 mm (2-stage / 2-stufig)
 a = 139.9 mm (3-stage / 3-stufig)
 b = 37.0 mm e = 19 h 7
 c = 31.0 mm f = 50 j 7
 d = 40.0 mm h1 = 9 mm, h2 = 5 mm

SPECIFICATIONS

Size / Baugröße		● PLD40	● PLD60	● PLD80	i	z ⁽²⁾	Size Page
Nominal Output Torque T _{2N} Abtriebs-Drehmoment T _{2N}	[Nm]	x	13	35	3	1	21
		4	14	45	4		
		4.5	16	45	5		
		4.5	15	43	7		
		4	x	x	9		
		x	14	35	10		
		5	19	55	16	2	
		5	19	55	20		
		5	21	58	25		
		5	21	55	28		
		5	21	58	35		
		x	21	55	40		
		5	x	x	49	3	
		x	21	58	50		
		x	17	50	70		
		x	16	35	100		
		5	x	x	64		
		5	x	x	80		
		5	x	x	100		
		x	21	55	120		
		5	x	x	140		
		x	21	55	160		
		5	x	x	175		
		x	21	58	200		
		5	x	x	245		
		x	21	58	250		
		5	x	x	343		
		x	21	58	350		
x	21	58	500				
x	19	50	700				
5	x	x	729				
x	18	35	1000				

Size / Baugröße		● PLD40	● PLD60	● PLD80	
efficiency / Wirkungsgrad		0.96	0.97	0.96	1-stage / 1-stufig
		0.94	0.94	0.94	2-stage / 2-stufig
		0.90	0.90	0.90	3-stage / 3-stufig
weight / Gewicht	[kg]	0.3	1.3	2.6	1-stage / 1-stufig
		0.4	1.7	3.5	2-stage / 2-stufig
		0.5	2.0	4.0	3-stage / 3-stufig
max. radial load / max. Radialkraft	[N]	220	930	1.770	1-stage / 1-stufig
max. axial load / max. Axialkraft	[N]	330	1.080	2.180	
max. radial load / max. Radialkraft	[N]	220	930	1.770	2-stage / 2-stufig
max. axial load / max. Axialkraft	[N]	330	1.080	2.180	
max. radial load / max. Radialkraft	[N]	220	930	1.770	3-stage / 3-stufig
max. axial load / max. Axialkraft	[N]	330	1.080	2.180	
backlash / Verdrehspiel	[arcmin]	20	12	10	1-stage / 1-stufig
		25	15	15	2-stage / 2-stufig
		30	20	20	3-stage / 3-stufig
initial speed / Eingangsdrehzahl		3000 min ⁻¹			
operating temp. / Betriebstemp.	[°C]	-25 up to +90 shortly +120 / -25 bis +90 kurzfristig +120			
lubrication / Schmierung		life time grease lubrication / Lebensdauer-Fettschmierung			

x → Gear Ratio not Standard Program / nicht im Standardprogramm

Reduction ratios **printed in bold** → Standard Series / **Fett gedruckte** Untersetzungen → Vorzugsreihe

(2) Number of Stages (2) = Anzahl der Getriebestufen

DIMENSIONS

UNIT = mm

● PLD 40 (for HECM26.../SECM26.../ECM26...)

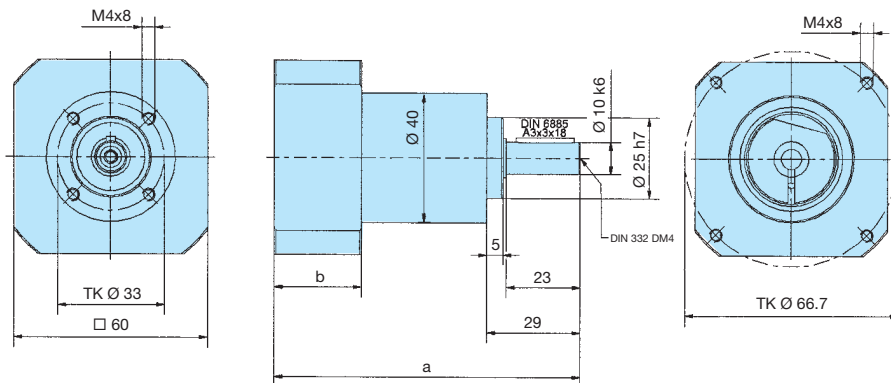

for SECM and ECM Stepping Motor

- a = 95 mm (1-stage / 1-stufig)
- a = 111 mm (2-stage / 2-stufig)
- a = 122 mm (3-stage / 3-stufig)
- b = 27 mm (1+2-stage / 1+2-stufig)
- b = 22 mm (3-stage / 3-stufig)

for HECM Stepping Motor

- a = 95 mm (1-stage / 1-stufig)
- a = 111 mm (2-stage / 2-stufig)
- a = 122 mm (3-stage / 3-stufig)
- b = 27 mm (1+2-stage / 1+2-stufig)
- b = 25 mm (3-stage / 3-stufig)

● PLD 60 (for HECM26.../SECM26.../ECM26...)

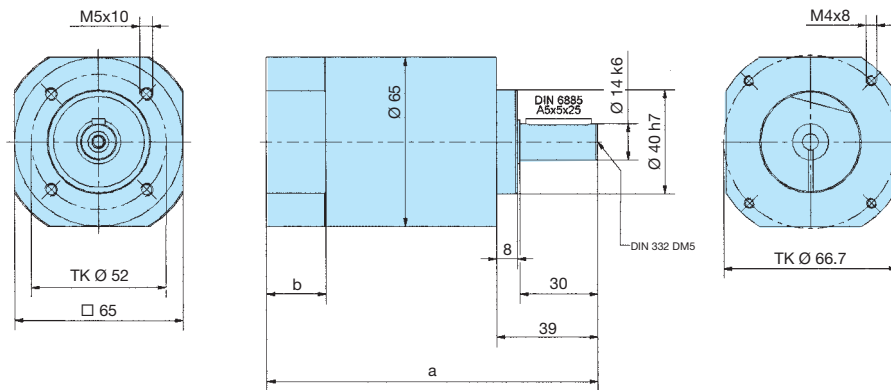

for SECM and ECM Stepping Motor

- a = 127.5 mm (1-stage / 1-stufig)
- a = 152 mm (2-stage / 2-stufig)
- a = 171 mm (3-stage / 3-stufig)
- b = 23 mm (1+2-stage / 1+2-stufig)
- b = 20 mm (3-stage / 3-stufig)

for HECM Stepping Motor

- a = 127.5 mm (1-stage / 1-stufig)
- a = 152 mm (2-stage / 2-stufig)
- a = 171 mm (3-stage / 3-stufig)
- b = 23 mm (1+2-stage / 1+2-stufig)
- b = 20 mm (3-stage / 3-stufig)

● PLD 80 (for HECM26...)

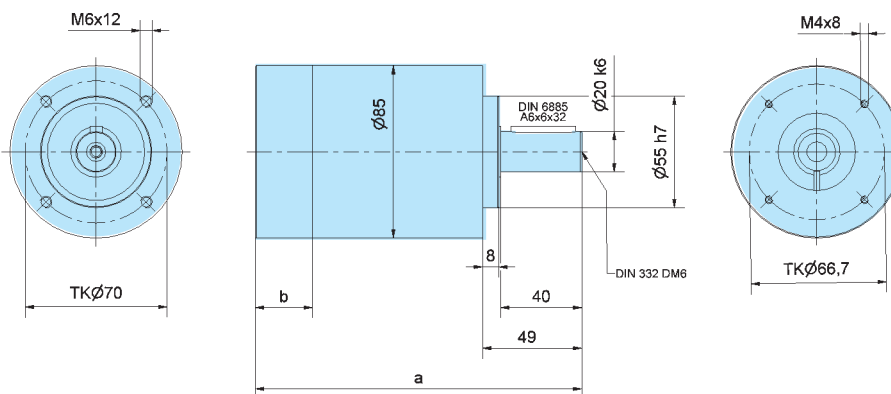

for HECM Stepping Motor

- a = 161 mm (1-stage / 1-stufig)
- a = 192 mm (2-stage / 2-stufig)
- a = 213 mm (3-stage / 3-stufig)
- b = 28 mm (1+2-stage / 1+2-stufig)
- b = 26 mm (3-stage / 3-stufig)

● PLD 80 (for SECM29...)

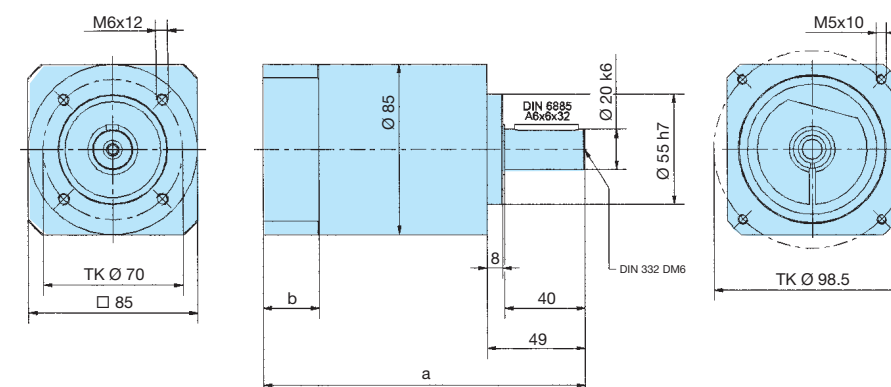

for SECM Stepping Motor

- a = 161 mm (1-stage / 1-stufig)
- a = 192 mm (2-stage / 2-stufig)
- a = 220 mm (3-stage / 3-stufig)
- b = 28 mm (1+2-stage / 1+2-stufig)
- b = 33 mm (3-stage / 3-stufig)

ECMD 2-PHASE-DRIVER

ECMD241... 0.5 - 1.25 A | 24 - 40 VDC



Steps/Revolution / Schritte/Umdrehung	1/1 - 1/2 - 1/4 - 1/16 Step
Supply Voltage / Eingangsspannung	from 24 VDC up to 40 VDC
Phase Current / Phasenstrom	from 0.5 A / Phase up to 1.25 A / Phase
Input Signal / Eingangssignale	from 3.5 VDC up to 24 VDC
Inputs / Eingänge	Puls, Direction, Gate, Reset
Dimensions / Abmessungen	L: / W: / H: 72mm / 72mm / 10mm
Features e.g. / Eigenschaften z.B.	automatic current down function
for following Stepmotor-Series / für folgende Schrittmotorserien	HECM21... HECM22... HECM24... SECM24...

ECMD242... 1.0 - 2.5 A | 24 - 40 VDC



Steps/Revolution / Schritte/Umdrehung	1/1 - 1/2 - 1/4 - 1/16 Step
Supply Voltage / Eingangsspannung	from 24 VDC up to 40 VDC
Phase Current / Phasenstrom	from 1.0 A / Phase up to 2.5 A / Phase
Input Signal / Eingangssignale	from 3.5 VDC up to 24 VDC
Inputs / Eingänge	Puls, Direction, Gate, Reset
Dimensions / Abmessungen	L: / W: / H: 72mm / 72mm / 10mm
Features e.g. / Eigenschaften z.B.	automatic current down function
for following Stepmotor-Series / für folgende Schrittmotorserien	HECM21... HECM22... HECM24... SECM24...

ECMD288... 1.5 - 8.0 A | 24 - 80 VDC



Steps/Revolution / Schritte/Umdrehung	1/1 - 1/2 - 2/5 - 1/5 - 1/10 - 1/12.5 - 1/25 - 1/50 Step
Supply Voltage / Eingangsspannung	from 24 VDC up to 80 VDC
Phase Current / Phasenstrom	from 1.25 A / Phase up to 8.0 A / Phase
Input Signal / Eingangssignale	from 3.5 VDC up to 24 VDC
Inputs / Eingänge	Puls, Direction, IN1 [Off, Reset, Gate]
Dimensions / Abmessungen	L: / W: / H: 112mm / 20mm / 79mm
Features e.g. / Eigenschaften z.B.	autom. current down function, active ballast circuit over-temp., -voltage, -current, undervoltage
for following Stepmotor-Series / für folgende Schrittmotorserien	HECM264 - HECM269 / SECM264 - SECM268 SECM264M - SECM268M / SECM296 - SECM2913

ECMD298... 4.0 - 10 A | 24 - 130 VDC



Steps/Revolution / Schritte/Umdrehung	1/1 - 1/2 - 2/5 - 1/5 - 1/10 - 1/12.5 - 1/25 - 1/50 Step
Supply Voltage / Eingangsspannung	from 24 VDC up to 80 VDC [max. 130 VDC]
Phase Current / Phasenstrom	from 4.0 A/Phase up to 10 A/Phase
Input Signal / Eingangssignale	from 3.5 VDC up to 24 VDC
Inputs / Eingänge	Puls, Direction, IN1 [Off, Reset, Gate]
Dimensions / Abmessungen	L: / W: / H: 157mm / 29mm / 79mm
Features e.g. / Eigenschaften z.B.	autom. current down function, active ballast circuit over-temp., -voltage, -current, undervoltage
for following Stepmotor-Series / für folgende Schrittmotorserien	HECM264 - HECM269 / SECM264 - SECM268 SECM264M - SECM268M / SECM296 - SECM2913

Zertifikat

Prüfungsnorm **ISO 9001:2015**
Zertifikat-Registrier-Nr. 01 100 026005

Unternehmen:



EC Motion Vertrieb und Entwicklung
für Antriebstechnik GmbH
Auf den Steinen 20
41812 Erkelenz
Deutschland

Geltungsbereich: Vertrieb von Antriebstechnikkomponenten

Durch ein Audit wurde der Nachweis erbracht, dass die
Forderungen der ISO 9001:2015 erfüllt sind.

Gültigkeit: Dieses Zertifikat ist gültig vom 01.08.2020 bis 31.05.2023.
Erstzertifizierung 2002

04.05.2020

TÜV Rheinland Cert GmbH
Am Grauen Stein - 51105 Köln

www.tuv.com TÜVRheinland®
Genau. Richtig.

© TÜV Rheinland TÜV und angrenzende Marken. Bildrechte sind Eigentum der jeweiligen Rechteinhaber.

Our Quality Control System, proof as has been furnished that
the requirements according to
TÜV Cert. DIN EN ISO 9001:2015.

Unser Qualitätssystem wurde hinsichtlich des Bereiches Ver-
trieb von Antriebskomponenten überprüft und offiziell mit dem
TÜV Zertifikat **DIN EN ISO 9001:2015**
ausgezeichnet.



On our homepage, which can now also be operated via mobile
devices, you will find our complete product range. Using the
Search functions or the Menu, you can quickly access the data
of the desired product. Give it a try!

*Auf unserer, jetzt auch über mobile Geräte bedienbaren
Homepage finden Sie unser komplettes Produktprogramm. Über
die Suchfunktionen oder dem Menue gelangen Sie schnell zu
den Daten des gewünschten Produktes. Probieren Sie es doch
einmal aus!*



EC Motion

Vertrieb und Entwicklung für Antriebstechnik GmbH
Glockensprung(neu) 8 - 41812 Erkelenz-Germany
Tel.: +49(0)2431-94206-0 - info@ec-motion.de