



INTRODUCTION & SELECTION GUIDE .. 73

PXL-10 74

PXL-20 76

PXU-20 78

PXT-10/11 80

PXT-20 82

PXR-10..... 84

PXF-10 86

PXF-20 88

PXC-10..... 90

SIGNAL CONVERTERS & ISOLATORS



INTRODUCTION

Process control and monitoring systems often utilise a large number of standard process signals; Voltage levels, current loops, temperature and pulsed signals to name but a few. When designing a system from scratch it may be possible to exactly match each type of sensor to a controller, but even then it is not always cost effective to do so.

PLCs and other controllers tend to be built in modular form, so to purchase a block of 8 analogue inputs just to cope with 1 analogue signal can be a very expensive exercise. When it comes to modifying existing systems, the problem becomes even worse. A substantial rebuild of the system is often necessary just to provide the facility of 1 or 2 extra inputs. Fortunately, a simple, cost effective solution is at hand - the PX range of threshold and signal converters.

With Brodersen PX Process Signal Conditioners, signals can be converted from one standard to another and even an analogue signal can be effectively fed into a digital input. The PX Signal Conditioner is a high quality product which has been designed and tested to the latest requirements for EMC immunity/emission and the low voltage directive (CE marked).

The PX Signal Conditioner also provides a galvanic isolation of 3.75kV. The PX relay is of a new design, supplied in a standardised industrial housing, 22.5mm wide, for mounting on 35mm symmetrical DIN-rail with touch-proof, combi notch-screw terminals. A snap-on cover on the front of the relay conceals the adjustment potentiometers.



	Input	Output	Adjust-ment	Galvanic Isolation	Description	Type	Page
	0-5, 0-10, -10-10 VDC 0-20, 4-20 mADC -125mV-1200mV Temp.Sensor PT 100 Temp.Sensor PT 1000 Frequency NPN/PNP/NAMUR 0-5, 0-1kOhm 0-500, 0-5000Ohm 0-1, 0-5A AC	Output Relay SPDT Solid State Output 0/4-20mA, 0/2-10V DC 0/4-20mA, 0-10V DC Frequency 0-10kHz 4-20mA	Setpoint/Hysteresis Offset/Gain ± 5%	Input/Output/Supply 3.75kV AC. Input/Output to supply 3.75kV AC.			
Threshold Relays	• •	•	•	•	Threshold Relay	PXL-10	74
	• •	•	•	•	Threshold Relay	PXL-20	76
Signal Conv./ Amplifiers	• •	•	•	•	Process Signal Conv.	PXU-20	78
	• •	•	•	•	Temp. Conv.	PXT-10	80
	• •	•	•	•	Temp. Conv.	PXT-11	80
	• •	•	•	•	Temp. Conv.	PXT-20	82
Signal Conv.	• •	•	•	•	Process Signal Conv.	PXR-10	84
	• •	•	•	•	Process Signal Conv.	PXC-10	90
Frequency Converters	• •	•	•	•	Analoque to Freq. Conv.	PXF-10	86
	• •	•	•	•	Frequency Conv.	PXF-20	88



DESCRIPTION

A threshold relay for the monitoring or control of common types of process signals. The process signal to be monitored is selected on the front panel and the threshold value is also adjusted via a setpoint potentiometer on the front of the relay. As the input signal attains the threshold plus the hysteresis the output relay energises. When the input signal drops and passes the threshold, minus hysteresis, the relay de-energises. The hysteresis is adjustable on the front, $\pm 0,5 - 20\%$.

By strapping 2 terminals, the relay can be inverted.

A red LED indicates if the relay is energised.

There is also a latch function where the relay after energising will remain energised, regardless of input, until the latch jumper or the operating voltage is disconnected. Typically used in safety circuits.

Features

- Input 0 - 5V/0-10V/-10-+10VDC/0-20/4-20mA in one version.
- Adjustable setpoint.
- Hysteresis adjustable $\pm 0,5-20\%$.
- Automatic locking (Latch).
- Inversion of relay function.
- Output SPDT.
- Operating voltage 24VDC, 24/115VAC or 24/230VAC.

VERSIONS/ORDERING CODES

Type:
Threshold relay

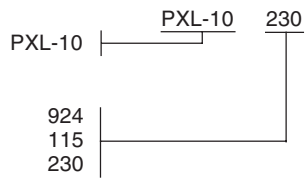

Supply voltage

- 24V DC
- 115V / 24V AC
- 230V AC / 24V AC

OPERATION

Output signal

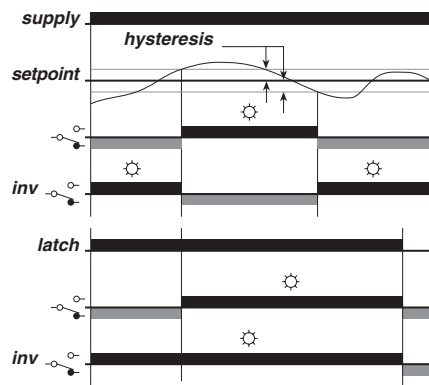

MECHANICAL DIMENSIONS

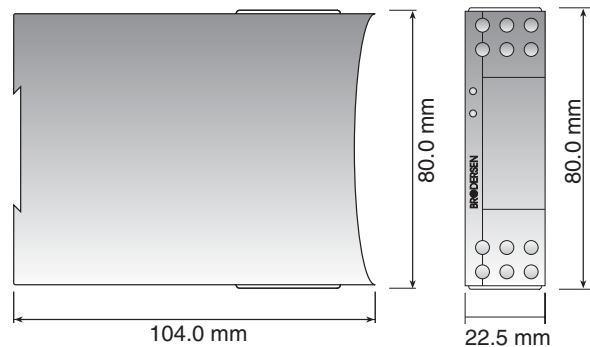

TECHNICAL DATA

Input:

Input signal	Impedance	$U_{max} = 50Vp-p$
0-5V DC	>100kOhm	
0-10V DC	>100kOhm	$I_{MAX} = 50mA$
-10-+10V DC	>100kOhm	
0-20mA DC	50 Ohm	
4-20mA DC	50 Ohm	

Selected via switches on the front panel.

Hysteresis: $\pm 0,5-20\%$ of range, adjustable.
Response time: Time constant ($\tau = \text{approx. } 0,3s$, worst case of response time max. $5xt$).

Upper critical frequency 30 Hz.

Output:

SPDT relay:	Contact material, AgNi 0,15 with hardened gold plating Au.
Max load AC:	8A/240V AC ($\cos \varphi=1$) Max. breaking capacity 2000VA. Inductive load. See fig. 1.
Max load DC:	8A/24V DC. Max. breaking capacity 50-270W. See fig. 2.
Max. in rush current:	15A (max. 4s/duty cycle less than 10%)
Min. in rush current:	10mA, 24V DC.
Frequency :	Max. 1000 operations pr. hour.
Life span:	Mech. Min. 3×10^7 operations. Elect. Min. 1×10^9 operations with full load.
Delay:	<20ms.

Supply voltage:

Versions:	924 = 24V DC (20,4-27,6)V DC 115 = 24/115V AC (20,4-27,6/98-132)V AC 230 = 24/230V AC (20,4-27,6/196-264)V
-----------	--

AC

Net frequency:	45-65Hz
Consumption:	AC; 3VA DC; 2W

General data:

Ambient temperature: -20 to 55°C.
Storage temperature: -40 to 80°C.
Mounting: 35mm DIN-rail (EN50022).
Terminals: Screw terminals with dual compartment.
Terminal screws are combined crosshead/slotted.
Up to 2 x 2,5mm² wire (2 x 1,5mm² inc. ferrule).
Recommended torque, 0,5Nm., max. 0,7 Nm. (VDE0609-1).
Terminal identification in accordance with DIN46199/EN50005.

Indicators:	Green LED = operating voltage. Red LED = relay switched on.
Protection:	IP20.
Electric isolation:	3,75kVAC (1 min.) between input, supply and relay output (EN60950).
Housing:	Noryl (GE), UL94V1.
Terminal block:	Noryl (GE), UL94V0.
Weight:	180 g.

WIRING DIAGRAM

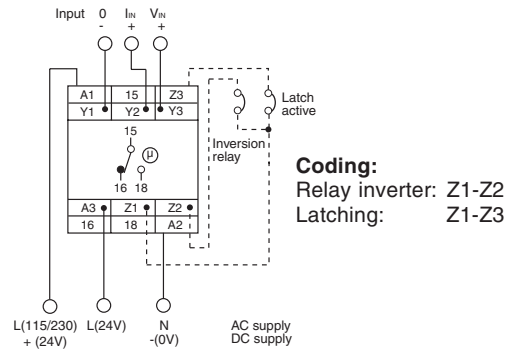

SPECIFICATIONS:

PXL-10 is designed and developed with regard to relevant specifications:

- EN60204-1 / VDE0113 electrical material on machines.
- VDE0110 / IEC664 Isolation specifications/creepage and clearance distances.
- Electrical safety in accordance with EN61010.
- IEC414 Safety regulations for control and monitoring equipment.
- EMC: Emission EN50081-1
Immunity EN50082-2
- Humidity in accordance with IEC68-2-3; RH=95%, 40°C.
- Vibration in accordance with IEC68-2-6:
- Shock when mounted, in accordance with IEC68-2-27.

PXL-10 is CE-marked in accordance with EMC-and the Low Voltage Directive.

OUTPUT LOAD DIAGRAMS

Fig. 1

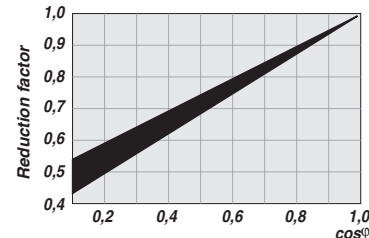
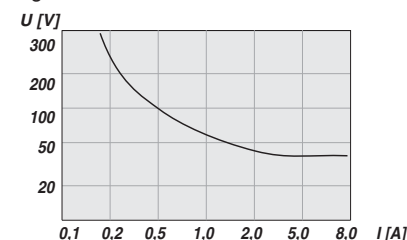

Fig. 2





DESCRIPTION

A threshold relay for the monitoring or control of common types of process signals. The process signal to be monitored is selected on the front panel and the threshold value is also adjusted via a setpoint potentiometer on the front of the relay. As the input signal attains the threshold plus the hysteresis the output relay energises. When the input signal drops and passes the threshold, minus hysteresis, the relay de-energises. The hysteresis is adjustable on the front, $\pm 0,5 - 20\%$.

By strapping 2 terminals, the relay can be inverted.

A red LED indicates if the relay is energised.

There is also a latch function where the relay after energising will remain energised, regardless of input, until the latch jumper or the operating voltage is disconnected. Typically used in safety circuits.

Features

- Input 0 - 5V/0-10V/-10-+10VDC/0-20/4-20mA in one version.
- Adjustable setpoint.
- Hysteresis adjustable $\pm 0,5-20\%$.
- Automatic locking (Latch).
- Inversion of relay function.
- Output Solid State no/nc.
- Operating voltage 24VDC, 24/115VAC or 24/230VAC.

VERSIONS/ORDERING CODES

Type:
Threshold relay

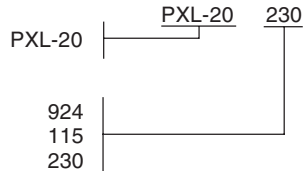

Supply voltage

- 24V DC
- 115V / 24V AC
- 230V AC / 24V AC

OPERATION

Output signal

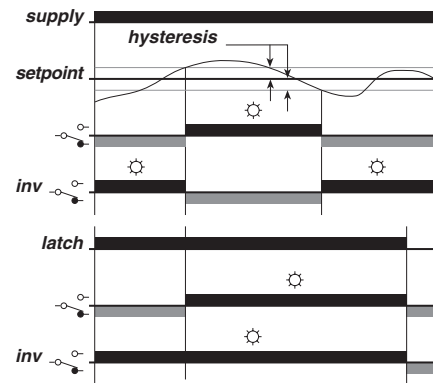

MECHANICAL DIMENSIONS

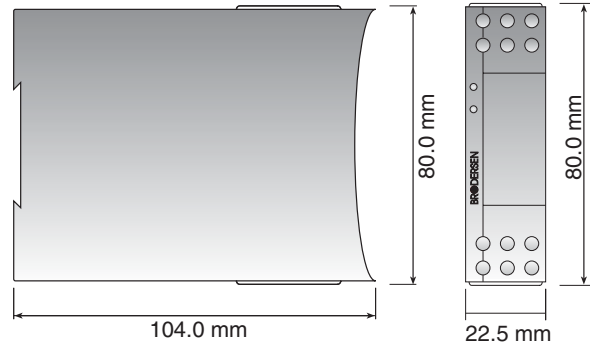

BLOCK DIAGRAM - SSR OUTPUT

Fig. 1

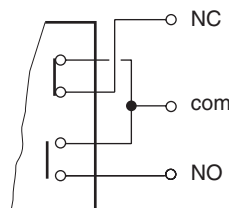

TECHNICAL DATA

Input:

Input signal	Impedance	$U_{MAX} = 50Vp-p$
0-5V DC	>100kOhm	
0-10V DC	>100kOhm	
-10-+10V DC	>100kOhm	$I_{MAX} = 50mA$
0-20mA DC	50 Ohm	
4-20mA DC	50 Ohm	

Selected via switch on the front panel.

Hysteresis: $\pm 0,5-20\%$ of range, adjustable.
Response time: Time constant ($\tau = \text{approx. } 0,1s$,
worst case of response time max. 5xt).

Upper critical frequency 30 Hz.

Output:

Solid state (NO/NC)
 $U_{MAX} = \pm 35V \text{ DC}/24VAC$
 $I_{MAX} = 100mA$
On resistor min. 15 ohm, max. 35 ohm.
Off state leak = max. 1 μA .
See fig. 1.

Supply voltage:

Versions: 924 = 24V DC (20,4-27,6)V DC
115 = 24/115V AC (20,4-27,6/98-132)V AC
230 = 24/230V AC (20,4-27,6/196-264)V

AC

Net frequency: 45-65Hz.

Consumption: AC; 3VA.
DC; 2W.

General data:

Ambient temperature:-20 to 55°C.
Storage temperature:-40 to 80°C.
Mounting: 35mm DIN-rail (EN50022).
Terminals: Screw terminals with dual compartment.
Terminal screws are combined crosshead/
slotted. Up to 2 x 2,5mm² wire
(2 x 1,5mm² inc. ferrule).
Recommended torque, 0,5Nm, Max. 0,7 Nm
(VDE0609-1).
Terminal identification in accordance with
DIN46199/EN50005.
Indicators: Green LED = operating voltage.
Red LED = relay switched on.
Protection: IP20.
Electric isolation: 3,75kVAC (1 min.) between input,
supply and relay output (EN60950).
Housing: Noryl (GE), UL94V1.
Terminal block: Noryl (GE), UL94V0.
Weight: 180 g.

WIRING DIAGRAM

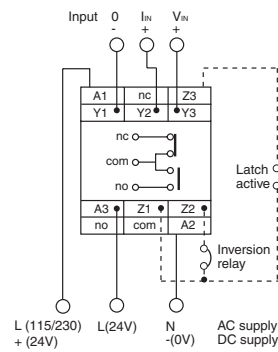

Coding:
Relay inverter: Z1-Z2
Latching: Z1-Z3

SPECIFICATIONS:

PXL-20 is designed and developed with regard to relevant specifications:

- EN60204-1 / VDE0113 electrical material on machines.
- VDE0110 / IEC664 Isolation specifications/creepage and clearance distances.
- Electrical safety in accordance with EN61010.
- IEC414 Safety regulations for control and monitoring equipment.
- EMC: Emission EN50081-1
Immunity EN50082-2
- Humidity in accordance with IEC68-2-3; RH=95%, 40°C.
- Vibration in accordance with IEC68-2-6.
- Shock when mounted, in accordance with IEC68-2-27.

PXL-20 is CE-marked in accordance with EMC and the Low Voltage Directive.

Signal Converters & Isolators

Process Signal Converter PXU-20



DESCRIPTION

Signal converter for the conversion of an analogue process signal to another type and /or to provide galvanic isolation. A typical application would be to convert a signal from a probe, not directly compatible with an analogue input of a PLC and/or provide galvanic isolation between input and output. Input, output and operating voltage are isolated to 3,75kV AC and are therefore suitable for applications suffering from potential differences/ground loops, high load resistor by long probe cables.

Input is selected via switches and output is selected via choice of terminals - See wiring diagram.

Features:

- Input 0-5V/0-10V/2-10V/-10+10VDC/0-20/4-20mA in one version.
- Output 0-10VDC/2-10VDC/0-20/4-20mA - selected via terminals.
- Output offset and gain adjustable $\pm 5\%$.
- LED indication of input less than 5% / i.e. indication of probe failure.
- Galvanically isolation supply/input/output is 3,75kV AC 1 min.
- Operating voltage 24V DC, 24V AC, 110 - 230V AC.

VERSIONS/ORDERING CODES

Type:	Process signal converter	PXU-20	PXU-20	230
Supply voltage	24V DC	924		
	24V AC	024		
	110-230V AC	230		

BLOCK DIAGRAM

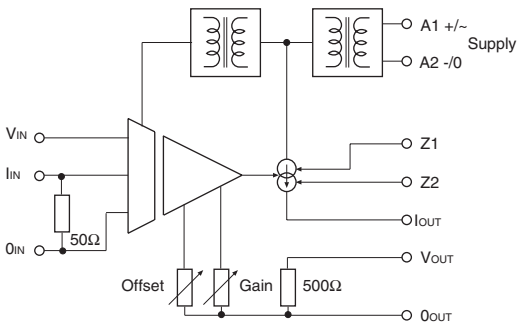

WIRING DIAGRAM

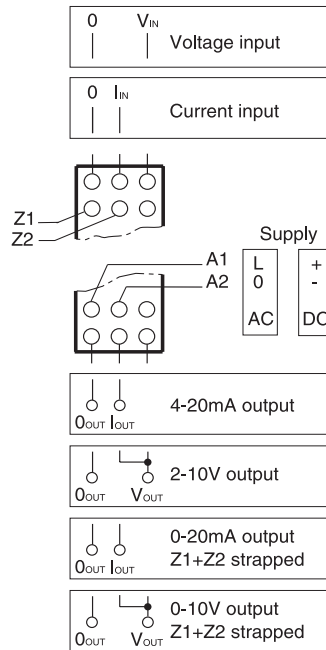

ADJUSTMENT

PXU-20 is delivered adjusted to offset = 0% and gain = 100%. To compensate for any loss in cables, etc. it is possible to adjust the output signal.

Remove the front cover. The offset (zero) and gain (span) on the output signal can be adjusted $\pm 5\%$ of max. signal. Put the cover back on to avoid any accidental adjustment of the relay. See fig. 1.

Fig. 1

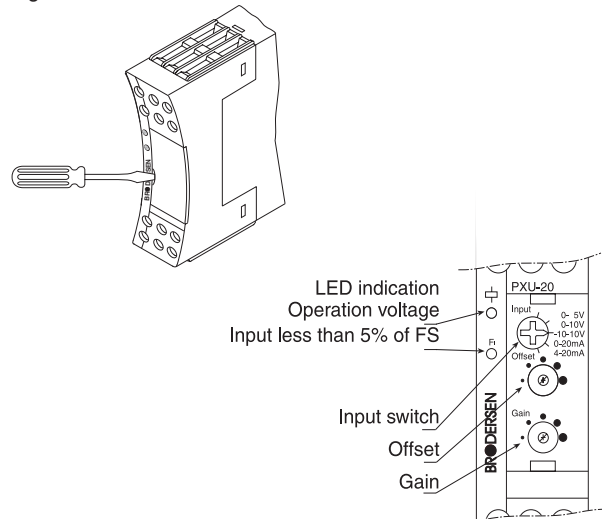

TECHNICAL DATA

Input signal

Input signal	Impedance	$U_{MAX} = 50V_{p-p}$
0-5V DC	100kOhm	
0-10V DC	100kOhm	$I_{MAX} = 50mA$
-10-+10V DC	100kOhm	
0-20mA DC	50 Ohm	
4-20mA DC	50 Ohm	

Selected via switches on the front panel.

Upper critical frequency 30 Hz.

Output:

Output signal	R_{MAX}
4-20mA DC	500 Ohm
0-20mA DC	500 Ohm
0-10V DC	via intern 500 Ohm shunt

Selected via terminals.

Offset(zero) and gain(span) are adjustable $\pm 5\%$. See. fig. 1.

Accuracy:	<1%, without adjustment.
Linearity:	<0,05% of full scale.
Temp. coefficient	0,02%/°C.
Ripple (RMS):	<0,1%.

Supply voltage:

Supply voltage	Consumption
24V DC (20,4-27,6)V DC	2W
24V AC (20,4-27,6)V AC	<3W.
110-230V AC (95-265)V AC	<3W.

All galvanically isolated 3,75kV AC 1 min. to input and output.

General data:

Ambient temperature:	-20 to 55°C.
Storage temperature:	-40 to 80°C.
Mounting:	35mm DIN-rail (EN50022).
Terminals:	Screw terminals with dual compartment. Terminal screws are combined crosshead/ slotted. Up to 2 x 2,5mm ² wire. (2 x 1,5mm ² inc. ferrule). Recommended torque, 0,5 Nm,max. 0,7Nm. (VDE0609-1).
Indicators:	Green LED = operating voltage. Yellow LED = input less than 5% of FS. (indication of cable failure).
Protection:	IP20.
Electric isolation:	3,75kVAC (1 min.) between input output and supply.
Housing:	Noryl (GE), UL94V1.
Terminal block:	Noryl (GE), UL94V0.
Weight:	170 g.

SPECIFICATIONS:

PXU-20 is designed and developed with regard to relevant specifications:

- EN60204-1 / VDE0113 electrical material on machines.
- VDE0110 / IEC664 Isolation specifications/creepage and clearance distances.
- Electrical safety in accordance with EN61010.
- IEC414 Safety regulations for control and monitoring equipment.
- EMC: Emission EN50081-1
Immunity EN50082-2
- Humidity in accordance with IEC68-2-3; RH=95%, 40°C.
- Vibration in accordance with IEC68-2-6.
- Shock when mounted, in accordance with IEC68-2-27.

PXU-20 is CE-marked in accordance with EMC-and the Low Voltage Directive.

MECHANICAL DIMENSIONS

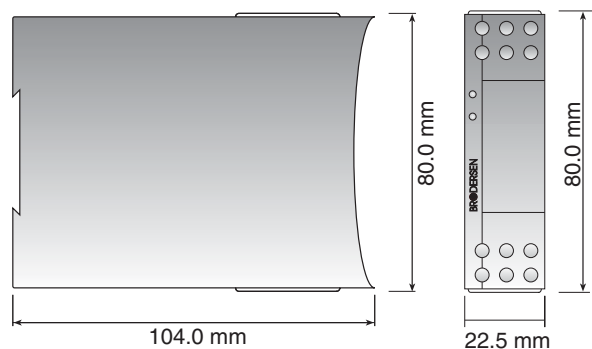



DESCRIPTION

Temperature converter for converting a temperature to an analogue process signal. The temperature converter has an Pt100/Pt1000 input in two ranges -50-300°C and -50-100°C. A typical application is where temperature measurement is required and when a PLC/Controller only has analogue inputs. The temperature range for input and type of analogue output are selected via choice of terminal - see connection diagram.

Features

- Pt100/Pt1000 probe input with/without compensation for cable resistance in two ranges -50 to 300°C and -50-100°C .
- Output 0-10VDC/2-10VDC/0-20/4-20mA - selected via terminals.
- Output offset and gain adjustable $\pm 5\%$.
- LED indication of input less than 5%.
- Galvanically isolated supply/output is 3,75kV AC 1 min.
- Operating voltage 24VDC, 24VAC, 115VAC or 230VAC.

VERSIONS/ORDERING CODES

Type:		PXT-10	924
Temperature converter Pt100	PXT-10		
Temperature converter Pt1000	PXT-11		
Supply Voltage			
24V DC		924	
24V AC		024	
115V AC		115	
230V AC		230	

BLOCK DIAGRAM

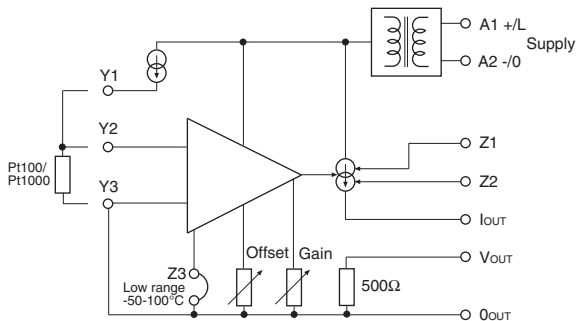

WIRING DIAGRAM

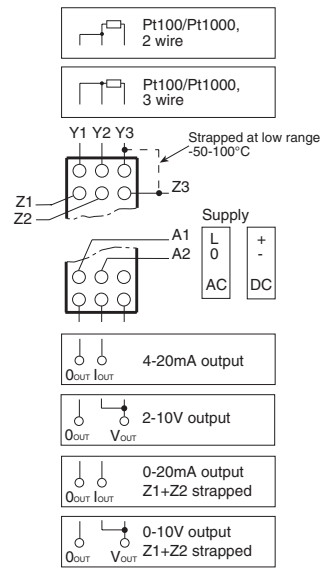

ADJUSTMENT

PXT-10/11 is delivered adjusted to offset = 0% and gain = 100%. To compensate for any loss in cables, etc. it is possible to adjust the output signal.

Remove the front cover. The offset (zero) and gain (span) on the output signal can be adjusted $\pm 5\%$ of max. signal. Put the cover back on to avoid any accidental adjustment of the relay. See fig. 1.

Fig. 1

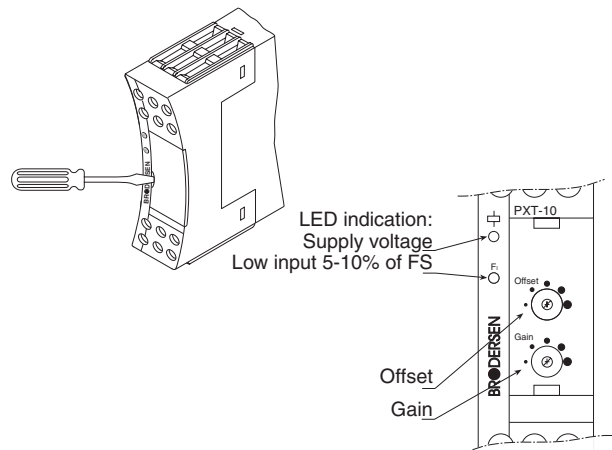

TECHNICAL DATA

Input signal

Pt100/Pt1000 probe (DIN43760/IEC751), 2 or 3 wire with compensation for cable resistance.

Temperature range.

-50-300°C
-50-100°C

Output:

Output signal	R_{MAX}
4-20mA DC	500 Ohm
0-20mA DC	500 Ohm
0-10V DC	via intern 500 Ohm shunt.

Selected via terminals.

Offset (zero) and gain (span) are adjustable $\pm 5\%$. See. fig. 1.

Accuracy:	<1%, without adjustment.
Linearity:	<0,05% of full scale.
Temp. coefficient	0,02%/°C.
Ripple (RMS):	<0,1%.

Supply voltage:

Supply voltage	Consumption
24V DC (20,4-27,6)V DC	2W
24V AC (20,4-27,6)V AC	3VA
115V AC (98-132)V AC	3VA
230V AC (196-264)V AC	3VA

All galvanically isolated 3,75kV AC 1 min. to output.

General data:

Ambient temperature:-20 to 55°C.
Storage temperature:-40 to 80°C.
Mounting: 35mm DIN-rail (EN50022).
Terminals: Screw terminals with dual compartment.
Terminal screws are combined crosshead/slotted. Up to 2 x 2,5mm² wire (2 x 1,5mm² inc. ferrule).
Recommended torque, 0,5Nm., max. 0,7 Nm. (VDE0609-1).
Indicators: Green LED = operating voltage.
Yellow LED = input less than 5% of FS.
Protection: IP20.
Electric isolation: 3,75kVAC (1 min.) between supply and input/output (EN60950).
Note:No galvanic isolation between sensor input and analogue output.
Housing: Noryl (GE), UL94V1.
Terminal block: Noryl (GE), UL94V0.
Weight: 170 g.

SPECIFICATIONS:

PXT-10/11 is designed and developed with regard to relevant specifications:

- EN60204-1 / VDE0113 electrical material on machines.
- VDE0110 / IEC664 Isolation specifications/creepage and clearance distances.
- Electrical safety in accordance with EN61010.
IEC414 Safety regulations for control and monitoring equipment.
- EMC: Emission EN50081-1
Immunity EN50082-2
- Humidity in accordance with IEC68-2-3; RH=95%, 40°C.
- Vibration in accordance with IEC68-2-6.
- Shock when mounted, in accordance with IEC68-2-27.

PXT-10/11 is CE-marked in accordance with EMC and the Low Voltage Directive.

MECHANICAL DIMENSIONS

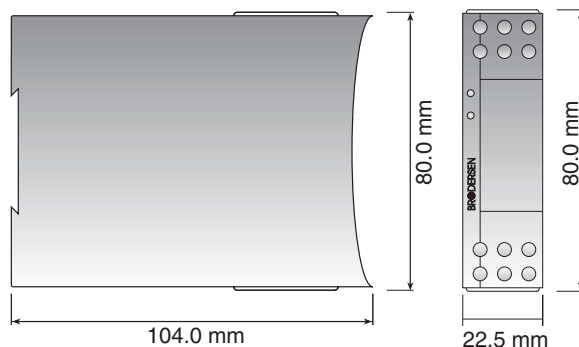



DESCRIPTION

Temperature converter for converting a temperature to an analogue process signal. The temperature converter has an Pt100 input in two ranges -50-300°C and -50-100°C. A typical application is where temperature measurement is required and when a PLC/Controller only has analogue inputs. The temperature range for input and type of analogue output are selected via choice of terminal - see connection diagram.

Features

- Pt100 probe input with/without compensation for cable resistance in two ranges -50 to 300°C and -50-100°C .
- Output 0-10VDC/2-10VDC/0-20/4-20mA - selected via terminals.
- Output offset and gain adjustable ±5%.
- LED indication of input less than 5%.
- Galvanic isolation supply/input/output of 3,75kV AC 1 min.
- Operating voltage 12-48VAC/DC, 115-230VAC.

VERSIONS/ORDERING CODES

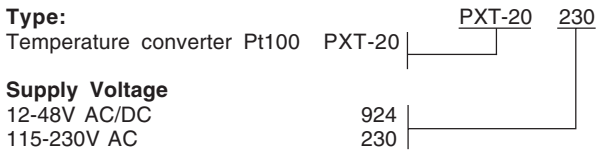

BLOCK DIAGRAM

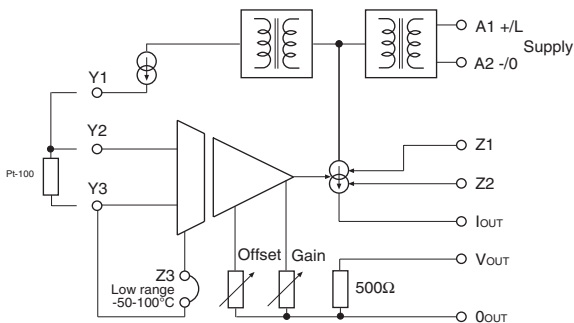

WIRING DIAGRAM

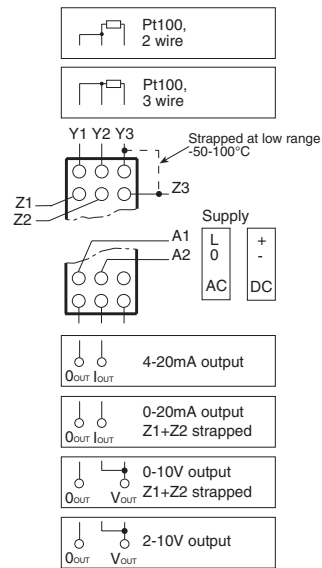

ADJUSTMENT

PXT-20 is delivered adjusted to offset = 0% and gain = 100%. To compensate for any loss in cables, etc. it is possible to adjust the output signal.

Remove the front cover. The offset (zero) and gain (span) on the output signal can be adjusted +/- 5% of max. signal. Put the cover back on to avoid any accidental adjustment of the relay. See fig. 1.

Fig. 1

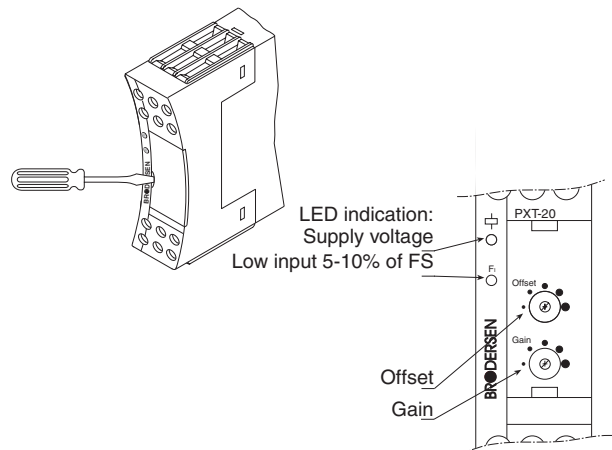

TECHNICAL DATA

Input signal

Pt100 probe (DIN43760/IEC751), 2 or 3 wire with compensation for cable resistance.

Temperature range.

-50-300°C
-50-100°C

Output:

Output signal	R_{MAX}
4-20mA DC	500 Ohm
0-20mA DC	500 Ohm
2-10V DC	via intern 500 Ohm shunt
0-10V DC	via intern 500 Ohm shunt

Selected via terminals.

Offset (zero) and gain (span) are adjustable $\pm 5\%$. See. fig. 1.

Accuracy:	<1%, without adjustment.
Linearity:	<0,15% of full scale.
Temp. coefficient	0,02%/°C.
Ripple (RMS):	<0,1%.

Supply voltage:

Supply voltage	Consumption
12-48V AC/DC (10,5-60)V AC/DC	<1,5W.
115-230V AC (60-264)V AC	<1W.

All galvanically isolated 3,75kV AC 1 min. to output.

General data:

Ambient temperature:	-20 to 55°C.
Storage temperature:	-40 to 80°C.
Mounting:	35mm DIN-rail (EN50022).
Terminals:	Screw terminals with dual compartment. Terminal screws are combined crosshead/slotted. Up to 2 x 2,5mm ² wire (2 x 1,5mm ² inc. ferrule). Recommended torque, 0,5Nm., max. 0,7 Nm. (VDE0609-1).
Indicators:	Green LED = operating voltage. Yellow LED = input less than 5% of FS.
Protection:	IP20.
Electric isolation:	3,75kVAC (1 min.) supply, input and output (EN60950).
Housing:	Noryl (GE), UL94V1.
Terminal block:	Noryl (GE), UL94V0.
Weight:	170 g.

SPECIFICATIONS:

PXT-20 is designed and developed with regard to relevant specifications:

- EN60204-1 / VDE0113 electrical material on machines.
- VDE0110 / IEC664 Isolation specifications/creepage and clearance distances.
- Electrical safety in accordance with EN61010.
IEC414 Safety regulations for control and monitoring equipment.
- EMC: Emission EN50081-1
Immunity EN50082-2
- Humidity in accordance with IEC68-2-3; RH=95%, 40°C.
- Vibration in accordance with IEC68-2-6.
- Shock when mounted, in accordance with IEC68-2-27.

PXT-20 is CE-marked in accordance with EMC and the Low Voltage Directive.

MECHANICAL DIMENSIONS

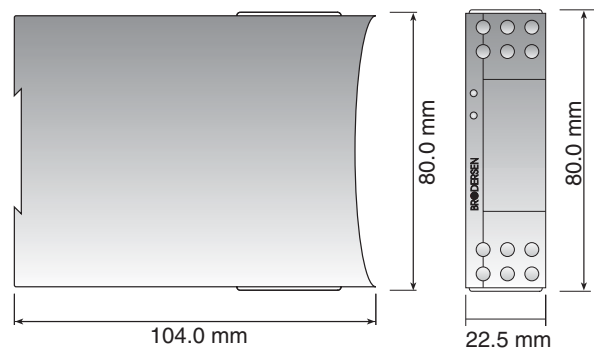



DESCRIPTION

Resistance to analogue converter for the conversion of a resistance to an analogue process signal with galvanic isolation. A typical application would be to convert a resistor probe to an analogue input of a PLC and provide galvanic isolation between input and output. Input, output and operating voltage are isolated to 3,75kV AC and are therefore suitable for applications suffering from potential differences.

The resistor input range and range and type of analogue output is selected via choice of terminals - See wiring diagram.

Features:

- Input 0 - 1kΩ and 0 - 5kΩ in one version.
- Output 0-10VDC/2-10VDC/0-20/4-20mA - selected via terminals.
- Output offset and gain adjustable ±5%.
- LED indication of input less than 5% / i.e. indication of probe failure.
- Galvanically isolation supply/input/output is 3,75kV AC 1 min.
- Operating voltage 12-48VAC/DC, 115-230VAC.

VERSIONS/ORDERING CODES

Type:
Converter

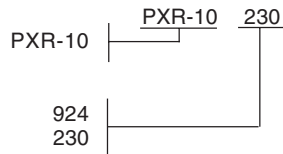

Supply voltage
12-48V AC/DC
115-230V AC

BLOCK DIAGRAM

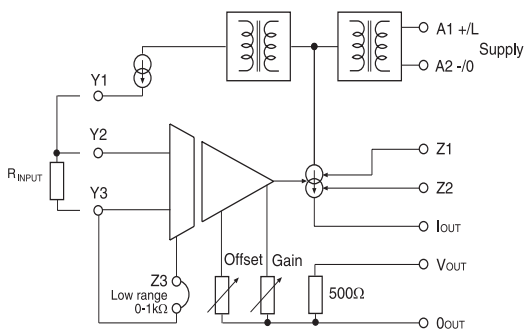

WIRING DIAGRAM

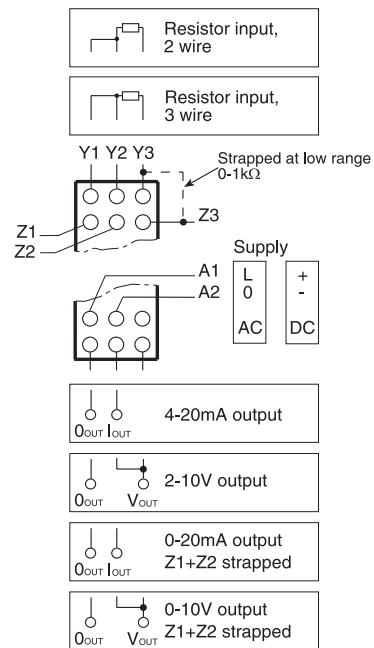

ADJUSTMENT

PXR-10 is delivered adjusted to offset = 0% and gain = 100%. To compensate for any loss in cables, etc. it is possible to adjust the output signal.

Remove the front cover. The offset (zero) and gain (span) on the output signal can be adjusted +/- 5% of max. signal. Put the cover back on to avoid any accidental adjustment of the relay. See fig. 1.

Fig. 1

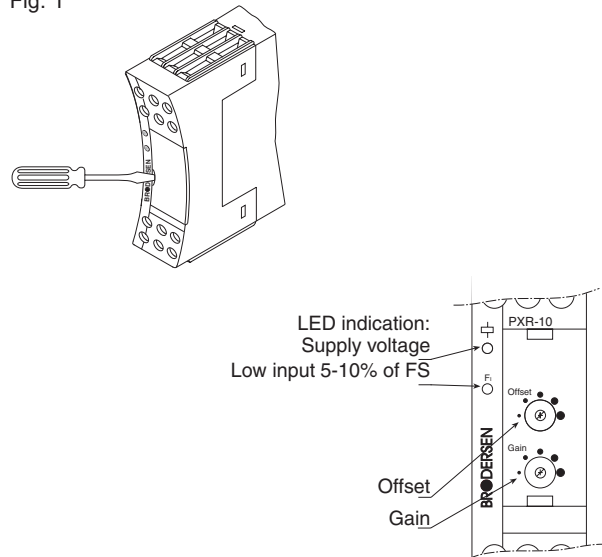

TECHNICAL DATA

Input signal

Resistor Input range
0-5kOhm
0-1kOhm

Range selected via coding Y3-Z3.

Output:

Output signal	R_{MAX}
4-20mA DC	500 Ohm
0-20mA DC	500 Ohm
2-10V DC	via intern 500 Ohm shunt
0-10V DC	via intern 500 Ohm shunt

Selected via terminals.

Offset(zero) and gain(span) are adjustable $\pm 5\%$. See. fig. 1.

Accuracy:	<1%, without adjustment.
Linearity:	<0,05% of full scale.
Temp. coefficient	0,02%/°C.
Ripple (RMS):	<0,1%.

Supply voltage:

Supply voltage	Consumption
12-48V AC/DC (10,5-60)V AC/DC	<1,5W.
115-230V AC (60-264)V AC	<1W.

All galvanically isolated 3,75kV AC 1 min. to input and output.

General data:

Ambient temperature:	-20 to 55°C.
Storage temperature:	-40 to 80°C.
Mounting:	35mm DIN-rail (EN50022).
Terminals:	Screw terminals with dual compartment. Terminal screws are combined crosshead/ slotted. Up to 2 x 2,5mm ² wire. (2 x 1,5mm ² inc. ferrule). Recommended torque, 0,5 Nm,max. 0,7Nm. (VDE0609-1).
Indicators:	Green LED = operating voltage. Yellow LED = input less than 5% of FS. (indication of cable failure).
Protection:	IP20.
Electric isolation:	3,75kVAC (1 min.) between input, output and supply.
Housing:	Noryl (GE), UL94V1.
Terminal block:	Noryl (GE), UL94V0.
Weight:	170 g.

SPECIFICATIONS:

PXR-10 is designed and developed with regard to relevant specifications:

- EN60204-1 / VDE0113 electrical material on machines.
- VDE0110 / IEC664 Isolation specifications/creepage and clearance distances.
- Electrical safety in accordance with EN61010.
- IEC414 Safety regulations for control and monitoring equipment.
- EMC: Emission EN50081-1
Immunity EN50082-2
- Humidity in accordance with IEC68-2-3; RH=95%, 40°C.
- Vibration in accordance with IEC68-2-6.
- Shock when mounted, in accordance with IEC68-2-27.

PXR-10 is CE-marked in accordance with EMC-and the Low Voltage Directive.

MECHANICAL DIMENSIONS

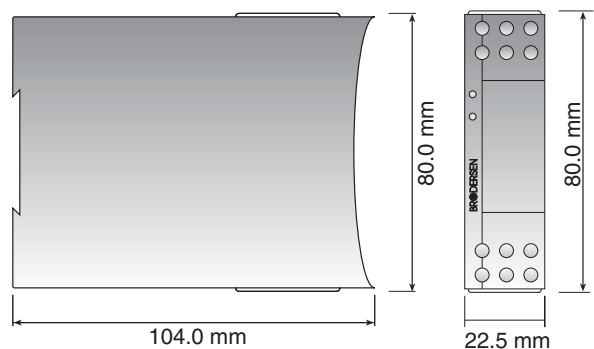

Signal Converters & Isolators

Process Signal To Frequency Converter PXF-10



DESCRIPTION

Signal converter for the conversion of an analogue process signal to a pulsating (50% duty cycle) transistor output. A typical application would be to convert an analogue signal from a probe to a pulsating output for input at a digital input of a PLC. Input, output and operating voltage are internally galvanically isolated (3,75kV). Input is selected via switches and output is selected via choice of terminals. See connecting diagram.

Features

- Input 0 - 5V/0 - 10V/-10-+10VDC/0 - 20/4 - 20mA in one version.
- 2 standard output versions;
 - Output 0-50Hz/0-5kHz/0-10kHz - selected via terminals.
 - Output 0-40Hz/0-4kHz/0-8kHz - selected via terminals.
- Output offset and gain adjustable $\pm 5\%$.
- LED indication of input less than 5% / indication on probe failure.
- Operating voltage 24VDC, 24VAC, 115VAC, 230VAC.

VERSIONS/ORDERING CODES

Type:
Process signal converter

Supply voltage

- 24V DC
- 24V AC
- 115V AC
- 230V AC

Output range

- 0-50Hz/0-5kHz/0-10kHz
- 0-40Hz/0-4kHz/0-8kHz

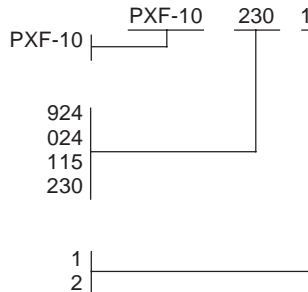

BLOCK DIAGRAM

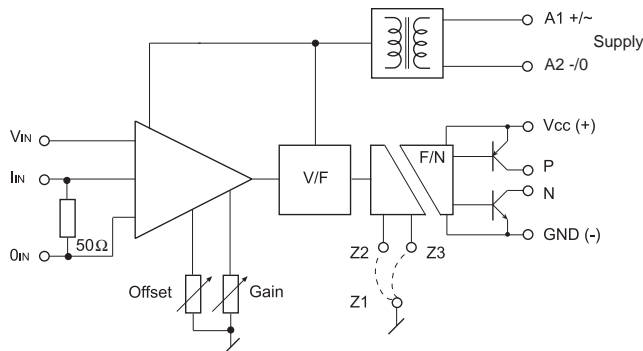

WIRING DIAGRAM

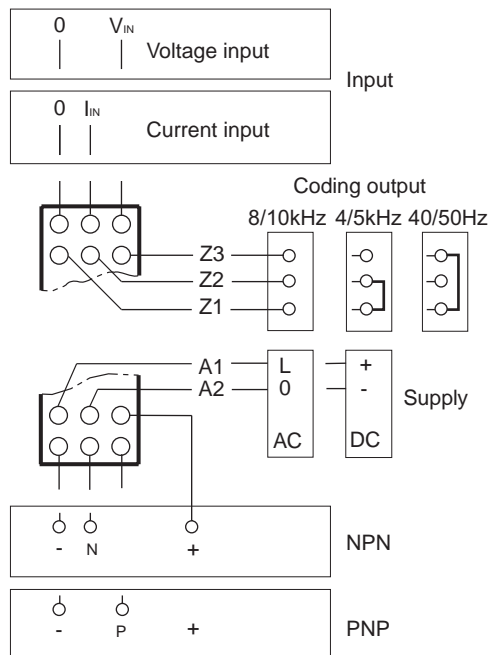

ADJUSTMENT

PXF-10 is delivered adjusted to offset = 0% and gain = 100%. To compensate for any loss in cables, etc. it is possible to adjust the output signal.

Remove the front cover. The offset (zero) and gain (span) on the output signal can be adjusted $\pm 5\%$ of max. signal. Put the cover back on to avoid any accidental adjustment on the relay. See fig. 1.

Fig. 1

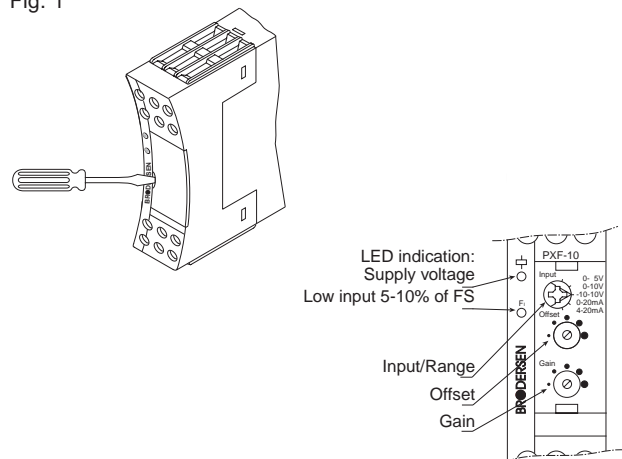

TECHNICAL DATA

Input signal

Input signal	Impedance	$U_{MAX} = 50Vp-p$
0-5V DC	1 MOhm	
0-10V DC	1 MOhm	
-10-+10V DC	1 MOhm	$I_{MAX} = 50mA$
0-20mA DC	50 Ohm	
4-20mA DC	50 Ohm	

Selected via switches on the front panel.

Output:

PNP/NPN transistor output 10-30V DC

Output ranges	V_{MAX}	I_{MAX}
0 - 8/0 - 10kHz	35V	100mA
0 - 4/0 - 5kHz	35V	100mA
0 - 40/0 - 50Hz	35V	100mA

Selected via terminals.

Offset (zero) and gain (span) are adjustable $\pm 5\%$. See. fig. 1.

Duty cycles:	50% (40-60%)
Accuracy:	<1%, without adjustment
Linearity:	<0,02% of full scale
Temp. coefficient	0,02%/°C

Supply voltage: Consumption

supply voltage	
24V DC (20,4-27,6)V DC	2W.
24V AC (20,4-27,6)V AC	3VA.
115V AC (98-132)V AC	3VA.
230V AC (196-264)V AC	3VA.

All galvanically isolated 3,75kV AC 1 min. to input and output.

General data:

Ambient temperature:	-20 to 55°C
Storage temperature:	-40 to 80°C
Mounting:	35mm DIN-rail (EN50022).
Terminals:	Screw terminals with dual compartment. Terminal screws are combined crosshead/slotted. Up to 2*2,5mm ² (2 x 1,5mm ² inc. ferrule). Recommended torque, 0,5Nm., max. 0,7Nm. (VDE0609-1).
Indicators:	Green LED = operating voltage. Yellow LED = input less than 5-10% of FS
Protection:	IP20.
Electric isolation:	3,75kVAC (1 min.) between input, output and supply (EN60950).
Housing:	Noryl (GE), UL94V1.
Terminal block:	Noryl (GE), UL94V0.
Weight:	170 g.

SPECIFICATIONS:

PXF-10 is designed and developed with regard to relevant specifications:

- EN60204-1 / VDE0113 electrical material on machines.
- VDE0110 / IEC664 Isolation specifications/creepage and clearance distances.
- Electrical safety in accordance with EN61010.
- IEC414 Safety regulations for control and monitoring equipment.
- EMC: Emission EN50081-1.
Immunity EN50082-2.
- Humidity in accordance with IEC68-2-3; RH=95%, 40°C.
- Vibration in accordance with IEC68-2-6.
- Shock when mounted, in accordance with IEC68-2-27.

PXF-10 is CE-marked in accordance with EMC and the Low Voltage Directive.

APPLICATIONS/WIRING

NPN

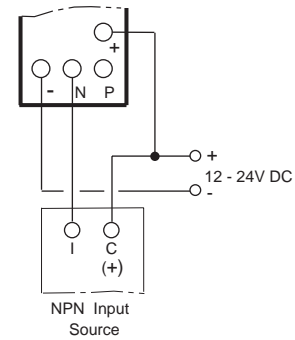

PNP

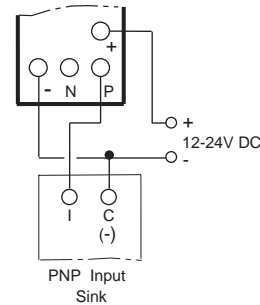

MECHANICAL DIMENSIONS

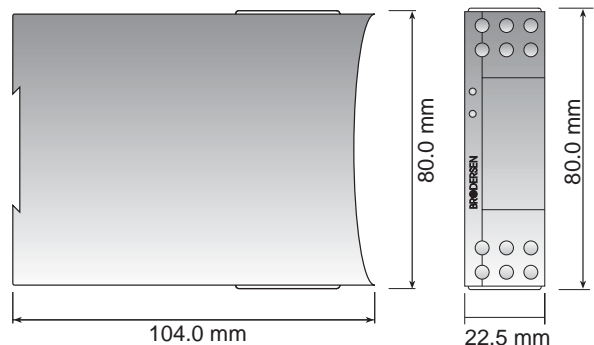



DESCRIPTION

Frequency converter for converting frequency to an analogue process signal. The frequency converter has NPN/PNP/NAMUR input in 5 ranges from 0-5kHz. The frequency range for input are selected by a rotary switch and type of analogue output are selected via choice of terminal - see connection diagram.

Features

- NPN/PNP/namur input in 5 ranges.
- Output 0-10VDC/2-10VDC/0-20/4-20mA - selected via terminals.
- Output offset and gain adjustable $\pm 5\%$.
- Yellow LED indication of input less than 5%.
- Galvanically isolated supply/output.
- Internal sensor supply 12,6V to 14V @ 0-20mA.
- Operating voltage 24-48V AC/DC, 115-230V AC.

VERSIONS/ORDERING CODES

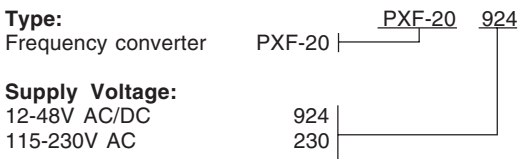

BLOCK DIAGRAM

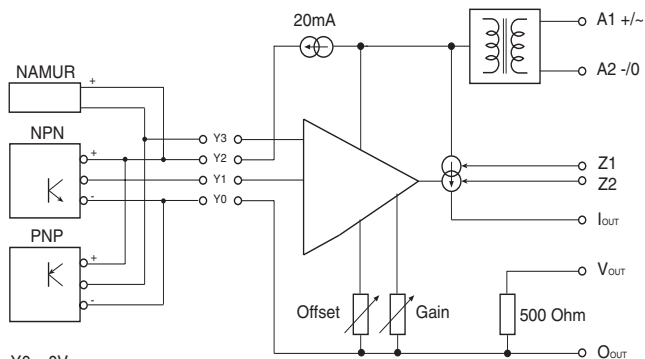

Y0: 0V
 Y1: Input NPN
 Y2: 12,6-14V @ 0-20mA
 Y3: Input PNP/NAMUR

WIRING DIAGRAM

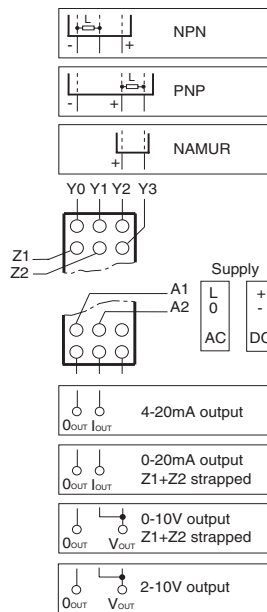

ADJUSTMENT

PXF-20 is delivered adjusted to offset = 0% and gain = 100%. To compensate for any loss in cables, etc. is it possible to adjust the output signal.

Remove the front cover. The offset (zero) and gain (span) on the output signal can be adjusted $\pm 5\%$ of max. signal. Put the cover back on to avoid any accidental adjustment of the relay. See fig. 1.

Fig. 1

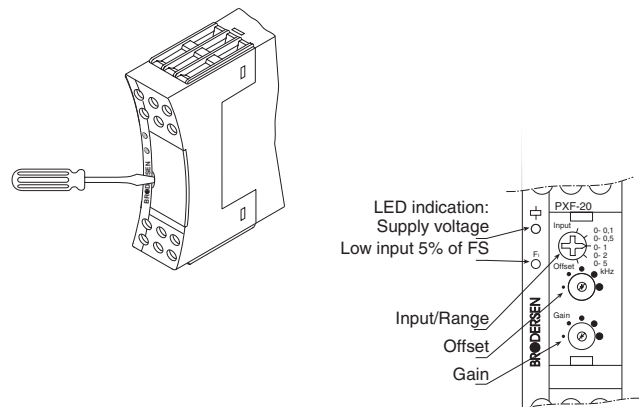

TECHNICAL DATA

Input signal:

NPN/PNP/NAMUR frequency input
Frequency ranges/selected by rotary switch.
0-100Hz
0-500Hz
0-1000Hz
0-2000Hz
0-5000Hz
Internal supply for sensor max. 20mA. Sensors with higher current consumption require external supply.

Input voltage levels:

PNP/NAMUR:	High > 5V	Low < 2,5V
NPN	High > 7,5V	Low < 5V
Max. voltage level:	35V DC.	

Min. pulse/pause time: 10µs

Output:

Output signal	R_{MAX}
4-20mA DC	500 Ohm
0-20mA DC	500 Ohm
0-10V DC	via internal 500 Ohm shunt.
2-10V DC	via internal 500 Ohm shunt.

Selected via terminals.

Offset (zero) and gain (span) are adjustable $\pm 5\%$. see. fig. 1.

Accuracy:	<1%, without adjustment.
Linearity:	<0,05% of full scale.
Temp. coefficient	0,02%/°C.
Ripple (RMS):	<0,1% at range >1kHz. <1% at range <1kHz.

Supply voltage:

Supply voltage	Consumption
12-48V AC/DC (10,5-60)V AC/DC	2W
115-230V AC (90-264)V AC	2W

All galvanically isolated 3,75kV AC 1 min. to input and output.

General data:

Ambient temperature:-20 to 55°C.
Storage temperature:-40 to 80°C.
Mounting: 35mm DIN-rail (EN50022).
Terminals: Screw terminals with dual compartment.
Terminal screws are combined crosshead/slotted. Up to 2 x 2,5mm² wire (2 x 1,5mm² inc. ferrule).
Recommended torque, 0,5Nm., Max. 0,7 Nm. (VDE0609-2)
Housing: Noryl (GE), UL94V1.
Terminal block: Noryl (GE), UL94V0.
Weight: 170 g.
Indicators: Green LED = operating voltage.
Yellow LED = input less than 5-10% of FS.
Protection: IP20.
Electric isolation: 3,75kVAC (1 min.) between supply, INPUT and supply (EN60950).
Note: No galvanic isolation between input and analogue output.

SPECIFICATIONS:

PXF-20 is designed and developed with regard to relevant specifications:

- EN60204-1 / VDE0113 electrical material on machines.
- VDE0110 / IEC664 Isolation specifications/creepage and clearance distances.
- Electrical safety in accordance with EN61010.
- IEC414 Safety regulations for control and monitoring equipment.
- EMC: Emission EN50081-1
Immunity EN50082-2
- Humidity in accordance with IEC68-2-3; RH=95%, 40°C.
- Vibration in accordance with IEC68-2-6.
- Shock when mounted, in accordance with IEC68-2-27.

PXF-20 is CE-marked in accordance with EMC and the Low Voltage Directive.

MECHANICAL DIMENSIONS

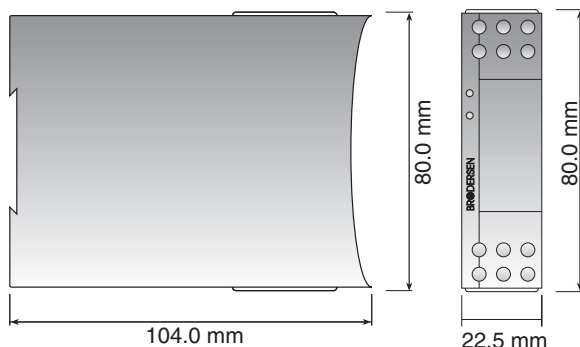

Signal Converters & Isolators

AC Current to Process Signal Converter PXC-10



DESCRIPTION

Signal converter for the conversion of an AC current signal to an analogue process signal. A typical application would be to convert a signal from a Current Transformer measuring high current to an analogue input of a PLC. Input, output and operating voltage are isolated to 3,75kV AC.

Input range and output type and range are selected via choice of terminals - See wiring diagram.

Features:

- 0-1A AC and 0-5A AC input in one version.
- Output 0-10VDC/2-10VDC/0-20/4-20mA - selected via terminals.
- Output offset and gain adjustable $\pm 5\%$.
- LED indication of input less than 5% / i.e. indication of probe failure.
- Galvanically isolation supply/input/output is 3,75kV AC 1 min.
- Operating voltage 12-48V AC/DC, 115-230VAC.

VERSIONS/ORDERING CODES

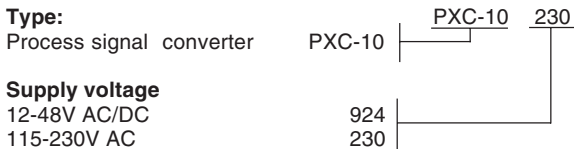

BLOCK DIAGRAM

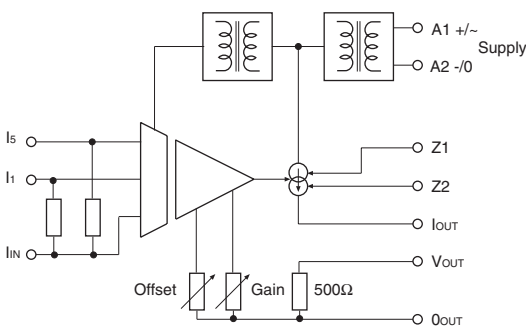

WIRING DIAGRAM

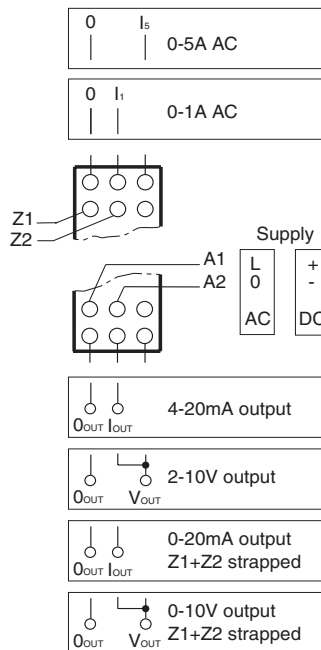

ADJUSTMENT

PXC-10 is delivered adjusted to offset = 0% and gain = 100%. To compensate for any loss in cables, etc. it is possible to adjust the output signal.

Remove the front cover. The offset (zero) and gain (span) on the output signal can be adjusted $\pm 5\%$ of max. signal. Put the cover back on to avoid any accidental adjustment of the relay. See fig. 1.

Fig. 1

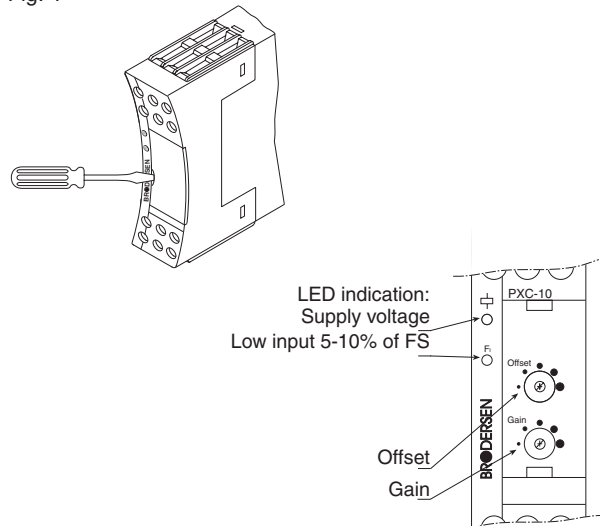

TECHNICAL DATA

Input:

Input signal	Impedance	I _{max}
0-1A AC	0,1Ohm	3A
0-5A AC	0,033Ohm	8A
Selected via choice of terminals.		
Frequency at		
AC-input:	45-65 Hz.	
Voltage drop:	Range:	1A:0,1V@FS 5A:0,17V@FS

Output:

Output signal	R _{MAX}
4-20mA DC	500 Ohm
0-20mA DC	500 Ohm
0-10V DC	via intern 500 Ohm shunt
Selected via terminals.	

Offset(zero) and gain(span) are adjustable ±5%. See. fig. 1.

Accuracy:	<2%, without adjustment.
Linearity:	<0,2% of full scale.
Temp. coefficient	<0,02%/°C.
Ripple (RMS):	<0,1%.

Supply voltage:

Supply voltage	Consumption
12-48V AC/DC (10,5-60)V AC/DC	<1W.
115-230V AC (60-264)V AC	<1W.

All galvanically isolated 3,75kV AC 1 min. to input and output.

General data:

Ambient temperature:	-20 to 55°C.
Storage temperature:	-40 to 80°C.
Mounting:	35mm DIN-rail (EN50022).
Terminals:	Screw terminals with dual compartment. Terminal screws are combined crosshead/ slotted. Up to 2 x 2,5mm ² wire. (2 x 1,5mm ² inc. ferrule). Recommended torque, 0,5 Nm,max. 0,7Nm. (VDE0609-1).
Indicators:	Green LED = operating voltage. Yellow LED = input less than 5% of FS. (indication of cable failure).
Protection:	IP20.
Electric isolation:	3,75kVAC (1 min.) between input output and supply.
Housing:	Noryl (GE), UL94V1.
Terminal block:	Noryl (GE), UL94V0.
Weight:	170 g.

SPECIFICATIONS:

PXC-10 is designed and developed with regard to relevant specifications:

- EN60204-1 / VDE0113 electrical material on machines.
- VDE0110 / IEC664 Isolation specifications/creepage and clearance distances.
- Electrical safety in accordance with EN61010.
- IEC414 Safety regulations for control and monitoring equipment.
- EMC: Emission EN50081-1
Immunity EN50082-2
- Humidity in accordance with IEC68-2-3; RH=95%, 40°C.
- Vibration in accordance with IEC68-2-6.
- Shock when mounted, in accordance with IEC68-2-27.

PXC-10 is CE-marked in accordance with EMC-and the Low Voltage Directive.

MECHANICAL DIMENSIONS

