



LENGTH GAUGE V00



GAUGE



APPLICATIONS

The gauge V00 is used to measure a part length within the machine cycle.

MAIN FEATURES

- Delivered with a mounting bracket for Tornos multispindles AS14 + SAS16.

TECHNICAL CHARACTERISTICS

- Precision	$\pm 5 \mu\text{m}$
- Environment	Oil, soluble

AMPLIFIER



MAIN FEATURES

Possibility to connect 1 sensor (single channel version) or 2 sensors (dual channel version).

ACCESSORIES

- Protective enclosure
> REF : **PC10**
- Cable extension cord SUB-D15
> REF : **PC04R015**

TECHNICAL CHARACTERISTICS

- Technology	Digital
- Amplifier power supply	110VAC/DC or 220VAC/DC
- Output relay power supply	48VAC/DC maxi
- Output voltage	Make + break relay: 1A maxi Static relay: 100mA maxi
- Operating temperature	0°C to + 50°C
- External dimensions	L 135mm, h 67,5mm, d 145mm
- Front panel dimensions	L 144mm, h 76mm, th 3mm
- Protection	IP65
- Unit of measure	mm or Inch
- Data output	Via RS232, ASCII format
- Language	English, German, Italian, Spanish, French
- Measurement mode	Peak / peak controlled / stabilized

SENSOR



MAIN FEATURES

-Axial sensor
-2 versions: standard (PC02A or PC02A15) or reinforced (PC02APR)

ACCESSORIES

- Sensor extension cord 1,5m..... > REF : **PC08015**
- Sensor extension cord 5m..... > REF : **PC0805**
- Sensor extension cord 10m..... > REF : **PC0810**

TECHNICAL CHARACTERISTICS

- Technology	LVDT
- Stroke	2 mm
- Cable diameter	8mm
- Cable length	4 m (PC02A + PC02APR) 1.5 m (PC02A15)

DIMENSIONS

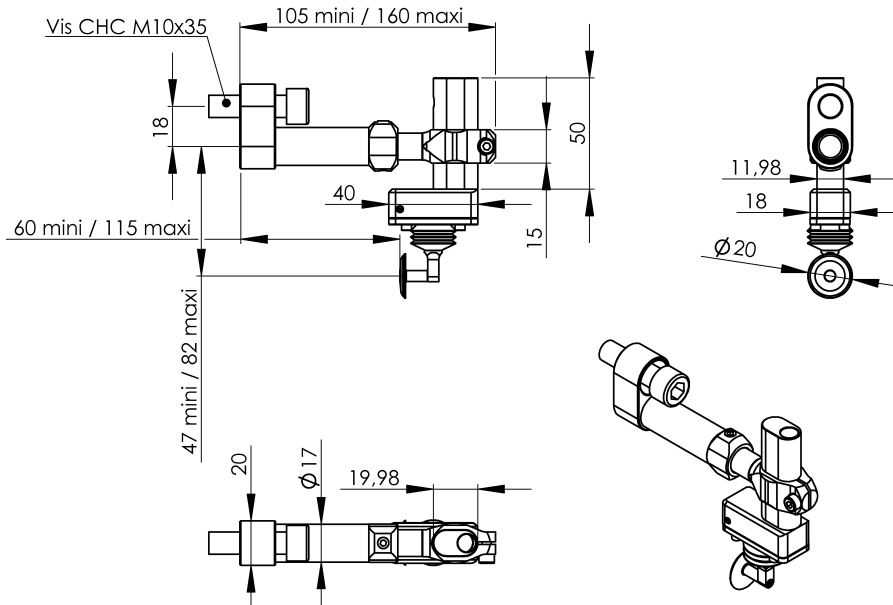

APPLICATIONS

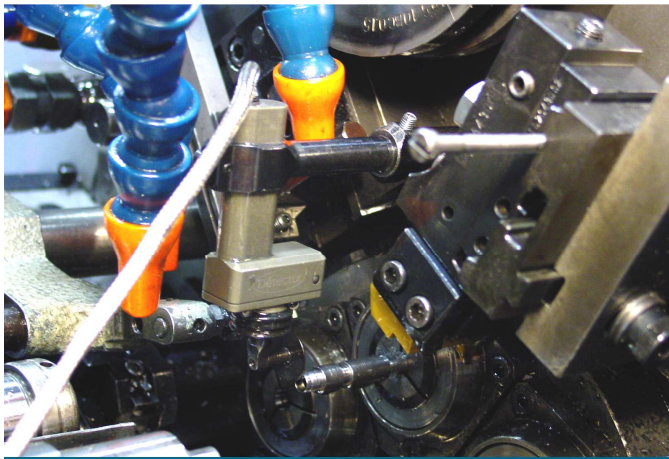

V00 - Tornos AS14

V00 - Tornos R12

