

SPIDER 15.75



PLATFORM[®]
BASKET
MAKE YOUR
JOB
EASIER

www.platformbasket.com

SPIDER 15.75



PRESTAZIONI SUPER SUPERIOR PERFORMANCES SUPER PERFORMANCES

Sbracci elevati in funzione del carico in navicella con una estensione massima di mt. 8,50 bordo navicella con 80 Kg.

Big working envelope providing a maximum outreach of up to 8,50 m. to edge of cage at 80 kg. load.

Grandes extensions en fonction de la charge dans le panier avec une extension max de 8,50 m du bord panier avec 80 kg.

COMANDI IDRAULICI HYDRAULIC CONTROLS COMMANDES HYDRAULIQUES

Permettono l'utilizzo della piattaforma semplificando quelle che sono le problematiche legate ai comandi elettro-idraulici.

Simply hydraulic operating system.

Ils permettent l'emploi de l'éleveur en simplifiant les problèmes liés aux commandes électro-hydrauliques.



VERSATILITA' VERSATILITY VERSATILITE

Permette, a cingoli chiusi grazie agli ingombri minimi, di accedere a spazi angusti o attraverso porte, mentre a cingoli allargati di accedere in luoghi impervi con la possibilità di superare pendenze fino al 24°.

Thanks to the compact dimensions with narrow track setting, it can pass through a doorway. With extended tracks it offers excellent terrainability, offering 24° gradeability.

Permet, grace aux dimensions réduites, avec chenilles rentrées, l'accès à espaces étroites ou travers des portes, et avec chenilles élargies, l'accès à espaces étroites avec la possibilité de dépasser pentes jusqu'au 24°.



TRASPORTO TRANSPORT TRANSPORT

Facilità di carico su mezzi con ausilio di rampe.

Easily transportable.

Facilité de charge avec des rampes.

CARATTERISTICHE TECNICHE

TECNICAL FEATURES

CARACTERISTIQUES TECHNIQUES

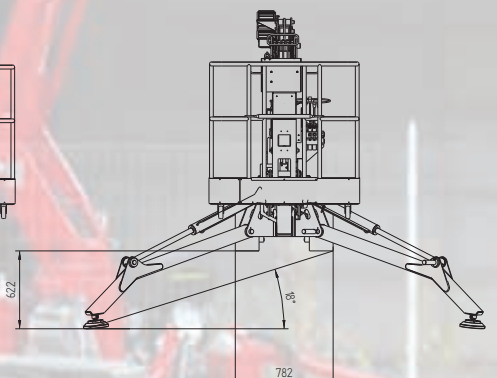
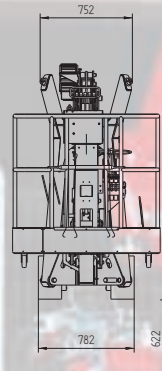
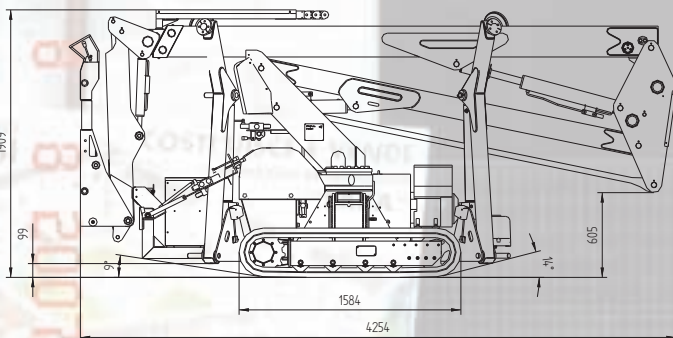
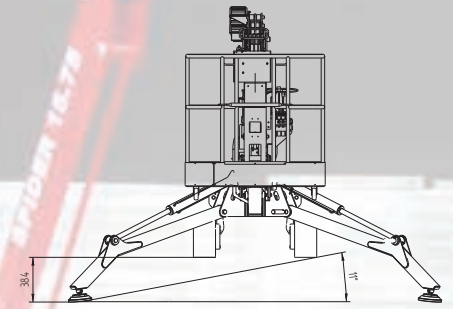
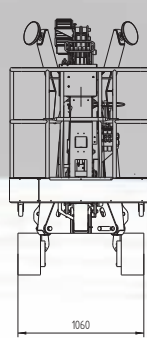
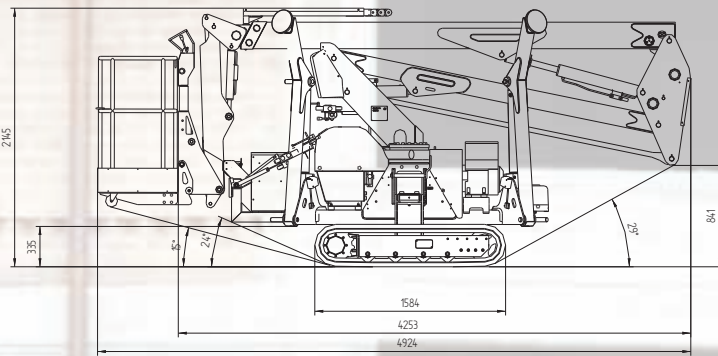
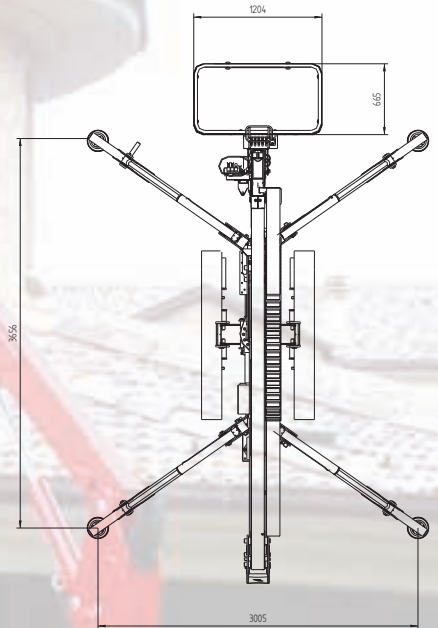
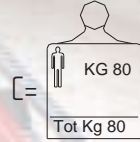
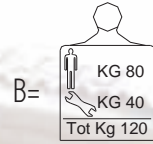
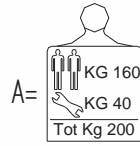
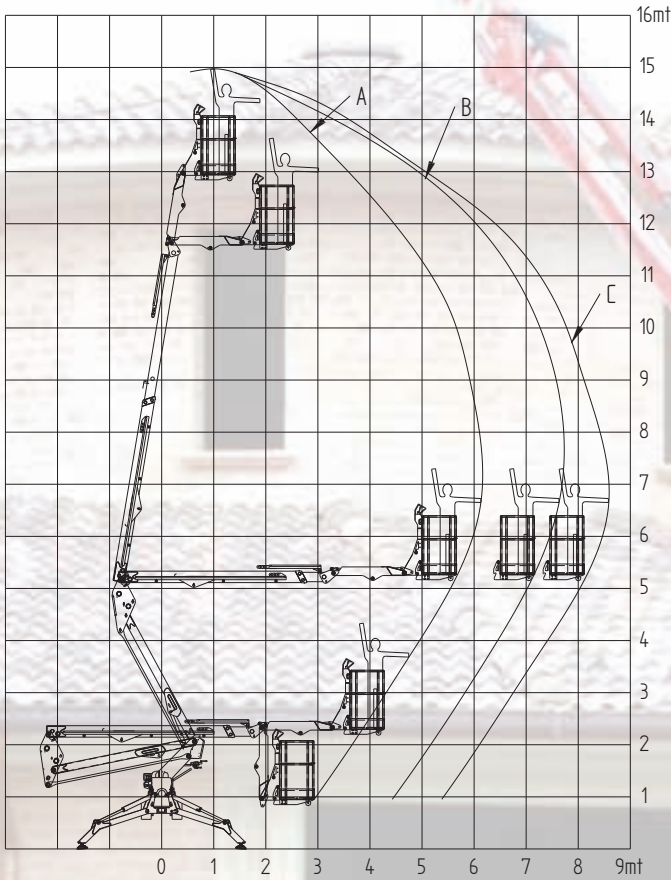

Dati dimensioni caratteristiche sono forniti a titolo indicativo e non impegnativo la PLATFORM BASKET si riserva il diritto di effettuare qualsiasi modifica senza alcun preavviso. Tutti i diritti sono di proprietà della PLATFORM BASKET ogni abuso verrà perseguito a norma di legge.

Data dimensions and features are indicative and not binding. Platform Basket reserves the right to do any changes without notice. All the rights belong to PLATFORM BASKET. Any abuse will be pursued following the rule of law.

Les données les dimensions les caractéristiques sont données a titre indicatif et n'engagé pas le maison. PLATFORM BASKET se réserve le droit d'effectuer toutes les modifications sans preavis. Tous les droits sont de propriété de PLATFORM BASKET et chaque abus sera poursuivi aux termes de la loi.

CARATTERISTICHE STANDARD
STANDARD FEATURES
 CARACTERISTIQUES STANDARD

CARATTERISTICHE TECNICHE
TECHNICAL FEATURES
 CARACTERISTIQUES TECHNIQUES

Pompa a mano d'emergenza Emergency hand pump Pompe manuelle d'urgence	Altezza di lavoro Working height Hauteur de travail	15.00 m.
Valvole di blocco su tutti gli attuatori Lock valves on all the actuators Valves de blocage sur les actuateur	Altezza di calpestio Working height to the basket floor Hauteur de travail au plancher	13.00 m.
Contaore Hour meter Computer-horaires	Sbraccio laterale Side outreach Deport laterale	8.50 m./ 80 Kg. 7.80 m./120 Kg. 6.00 m/ 200 Kg.
Interblocco bracci/stabilizzatori Stabilisers/booms interblock Interblocage stabilisateurs/bras	Rotazione torretta Turret rotation Rotation tourelle	359° 359° 359°
Limitatore di momento Limiting device system Limiteur de deport	Dimensioni navicella Cage dimensions Dimensions panier	1.20x0.66x1.10 m.
Cingoli in gomma nero Black rubber tracks Chenille en caoutchuc noir	Lunghezza massima Length Longueur	4.25/4.92 m.
Cingoli allargabili meccanicamente Mechanical Extensible tracks Extensible Chenilles mecanique	Larghezza Width Largeur	Min. 0.78 m./Max 1.06 m.
OPTIONALS/OPTIONALS/OPTIONS	Altezza a riposo Height in stowed position Hauteur a machine repliee	Min 1.91 m./Max 2.15 m.
Elettropompa 110/220/380 V 110/220V/380V Motor pump Electropompe 110/ 220/380V	Ingombro macchina stabilizzata Overall dimensions with stabilised machine Encombrement machine stabilisee	3.00x3.65 m.
Elettropompa d'emergenza 12V Emergency motor pump 12V Electropompe d'urgence 12V	Velocità traslazione Driving speed Vitesse de deplacement	0-2.0 Km./h
Pres a aria acqua in navicella Air water outlet in the cage Prise air eau dans le panier	Pendenza massima Gradeability Pente max	24°
Pres a corrente 220V in navicella 220V outlet in the cage Prise electrique dans le panier	Portata massima Max capacity Max capacite	200 Kg.
Cingoli antitraccia No marking tracks Chenilles pas marquants	Motore benzina Petrol engine Moteur a essence	9 Kw.
Colori personalizzati Personal colours Couleur personnalisee	Motore Diesel Diesel engine Diesel moteur	6.8 Kw.
Kit anticollisione Anti-collision kit	Peso totale macchina base Total weight of the machine Poids total de la machine	1850 Kg.