

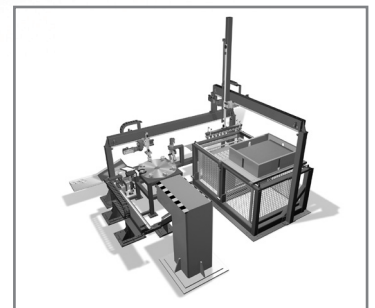

lifgo® | lean SL® | leantranspo®

Gear rack gearboxes and systems

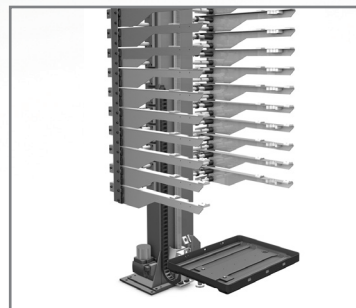
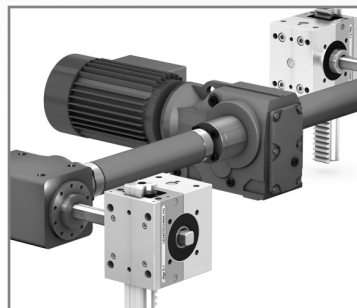
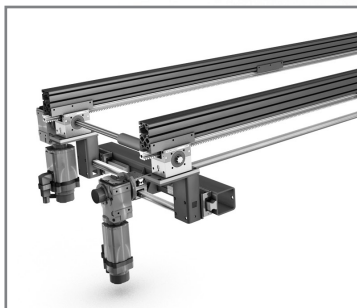
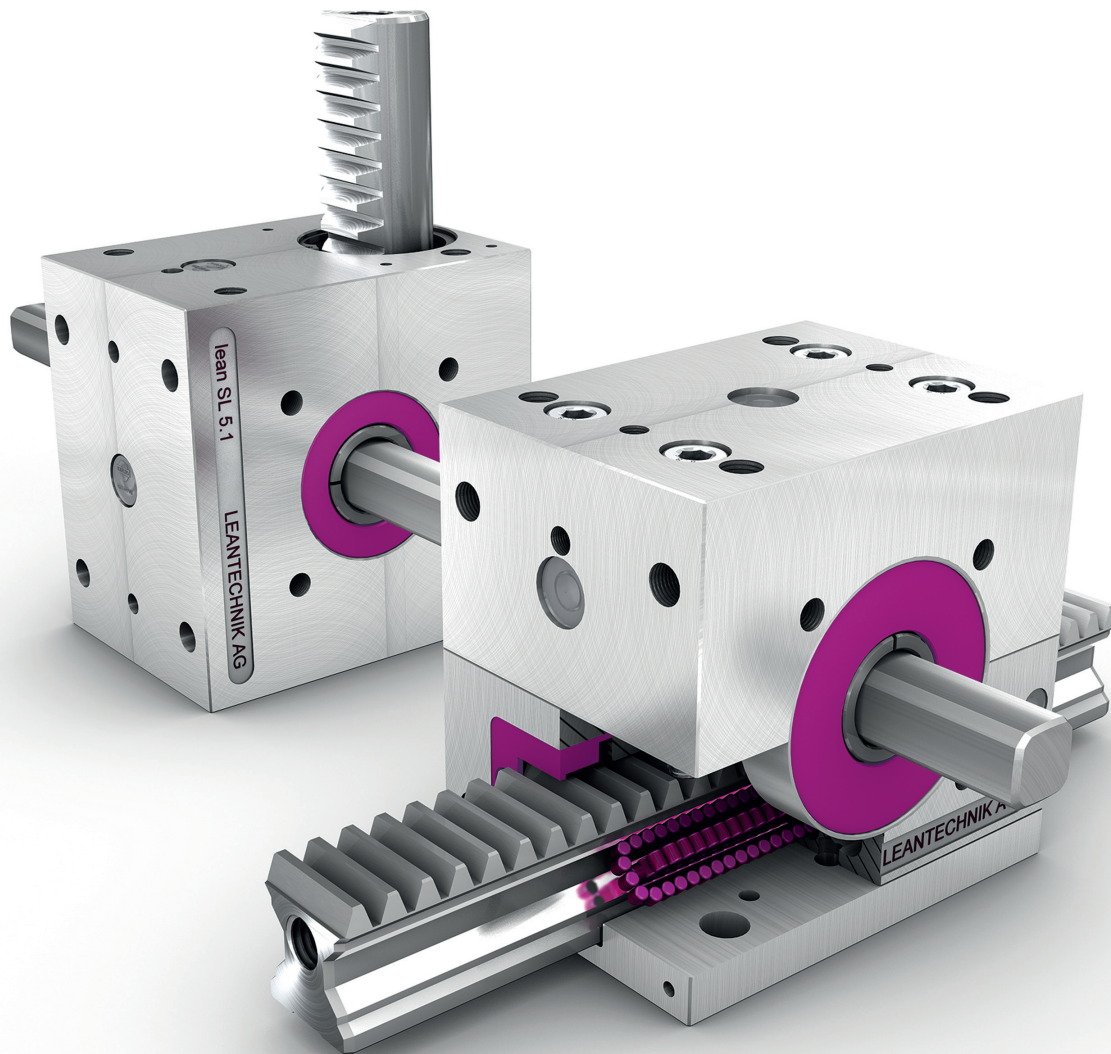

LEANTECHNIK AG

www.leantechnik.com



LEANTECHNIK AG gear rack gearboxes

lifgo® & lean SL® 5 are two series of gear rack gearboxes that can be combined with one another. As parts of an innovative, modular system, they complement one another perfectly in the design of installations capable of synchronous lifting and transfer movements. A special feature of the modular system is the unique level of compatibility provided by the two systems.

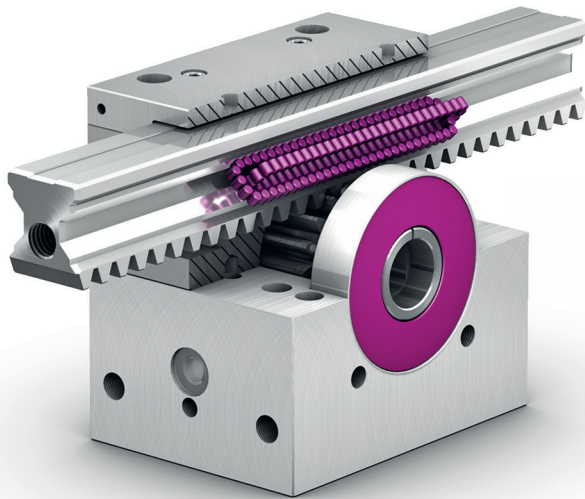

lifgo® with linear gear rack guides for fast, precise, synchronous installations that meet demanding requirements

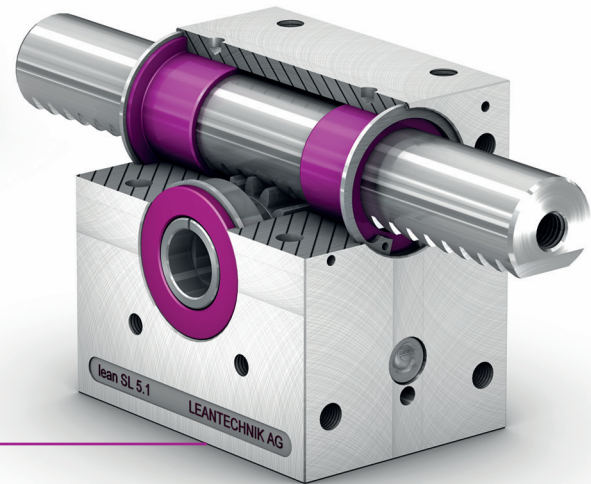

lean SL® with round gear rack guides for simple, synchronous lifting tasks

A logical modular approach has been adopted in order to develop a set of compatible components that offer design engineers the flexibility needed to cover a wide range of applications using only a small number of accessories. From a simple lift table to a complex transfer and shuttle system, the modular components mean anything is possible, with the proven quality of **LEANTECHNIK AG**.

The combination of two series of gearboxes with complementary properties permits the economical development of extremely varied systems and installations.

Operating principle

Both series convert linear movements into rotary movements and vice versa. Thanks to this underlying principle, it is possible to meet a wide range of challenges from simple through to highly demanding lifting tasks.



lifgo®

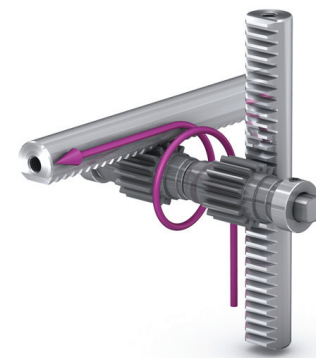

lean SL®



The key facts...

- **lifgo® & lean SL® can be combined with one another**
- **numerous options for flexible mounting**
- **long service life for durable use**
- **simple installation with few accessories**
- **4 pinion shaft ends per size for all connection types**
- **effective gear rack protection – simple and flexible**

lifgo®

- high-precision, 4-way roller guides
- high positioning accuracy
- high lifting speed
- high transverse force bearing capacity
- 4 model variants available in three sizes

lean SL®

- simple, robust sliding guide bearing
- simplified positioning accuracy
- medium lifting speed
- low transverse force bearing capacity
- 2 model variants available in three sizes

Modular principle

Identical sizes, connection dimensions and pinion shaft ends mean that the two gearbox types can be combined as elements in an easy-to-use modular system. The system is rounded off by the „double“ variants of lifgo® and lean SL® as well as the lifgo® linear and lifgo® linear double models for horizontal travel paths. Together, the modules provide the greatest possible level of versatility during the task of plant construction.

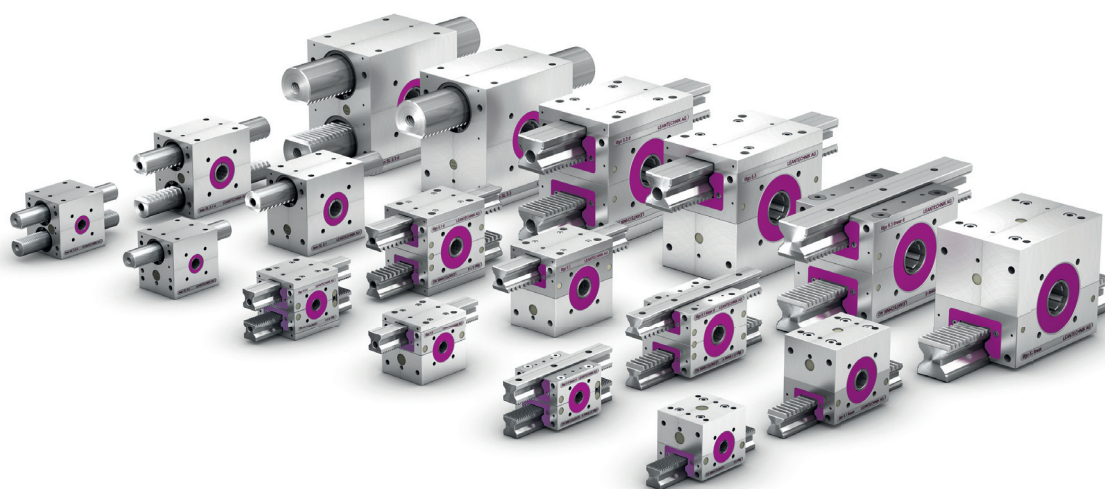

From drive accessories through to gear rack protection mechanisms, our accessory components – some of which can be used in different series – complete the modular system and simplify design and assembly work.





lifgo® & lean SL® 5

Positioning, mounting and combining the gearboxes

The lifgo® and lean SL® gear rack gearboxes can be bolted in place in all positions from either above or below. Gearboxes of the same size are mutually interchangeable.

lifgo®

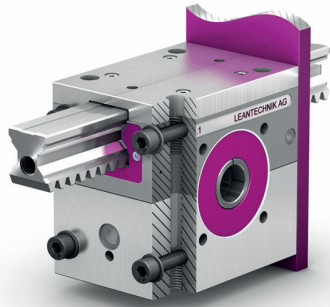

lean SL®

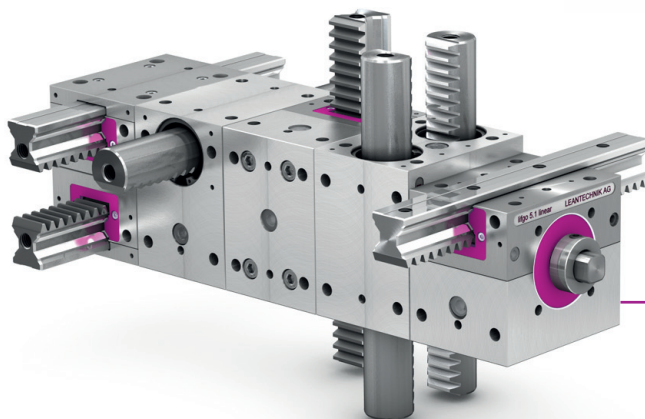
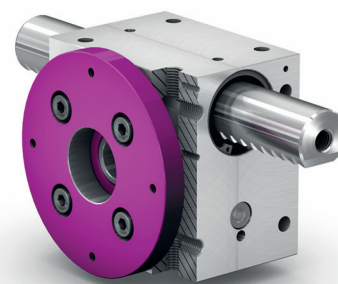
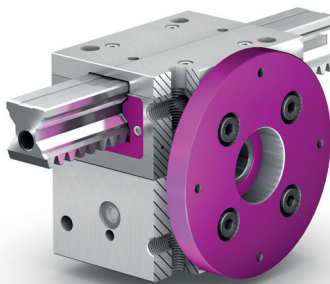
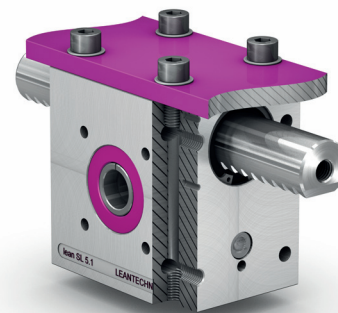
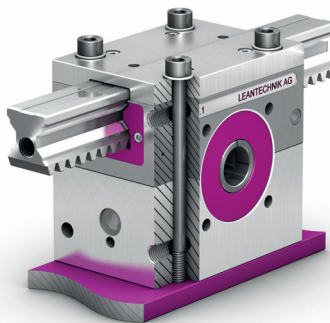
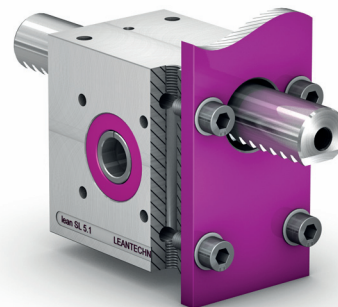

Thanks to their compatibility, the gearboxes from both series can be connected in all conceivable combinations, including at angles of $\pm 90^\circ$.





Gearbox variants

lifgo® & lean SL® double

lifgo® double and lean SL® double can be used to perform centring movements and/or gripping movements, for example in shuttle installations. The gearboxes are equipped with two gear racks that run in parallel but in opposite directions.

lifgo® double

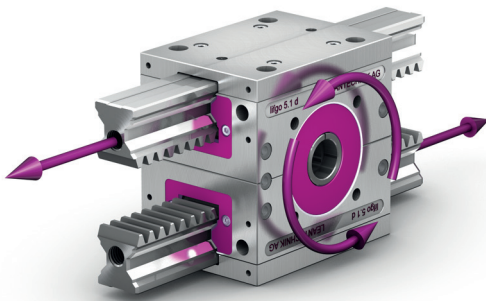

lean SL® double

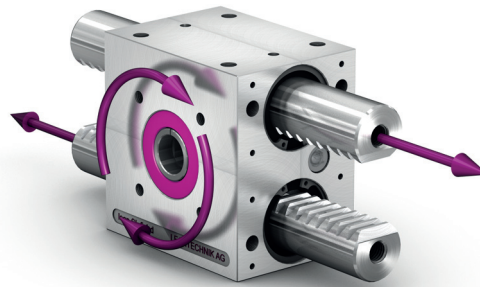

lifgo® linear

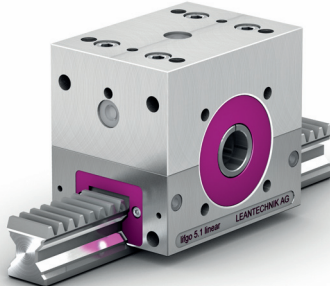

lifgo® linear for long stroke lengths

lifgo® linear is the solution when long stroke lengths are required. To achieve this, the gear racks are arranged **behind one another** like rails. lifgo® linear can be mounted either vertically or horizontally and is also available in an eccentric variant.

lifgo® eccentric with adjustable tooth flank clearance

In the lifgo® "eccentric" version, the tooth flank clearance can be precisely adjusted. As a result, you can determine the required positioning accuracy yourself.

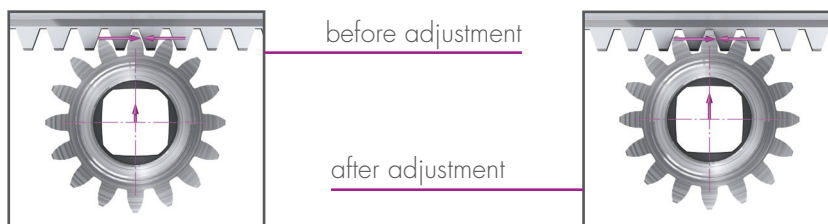

lifgo® linear is also available in an „eccentric“ design.



Rotationally rigid connection with profile shaft

A rotationally rigid, interlocked and synchronous connection between the gearboxes can be achieved, for example, through the insertion of a profile shaft. Identically aligned tooth positions are ensured even at a relative angle of 90° to one another.

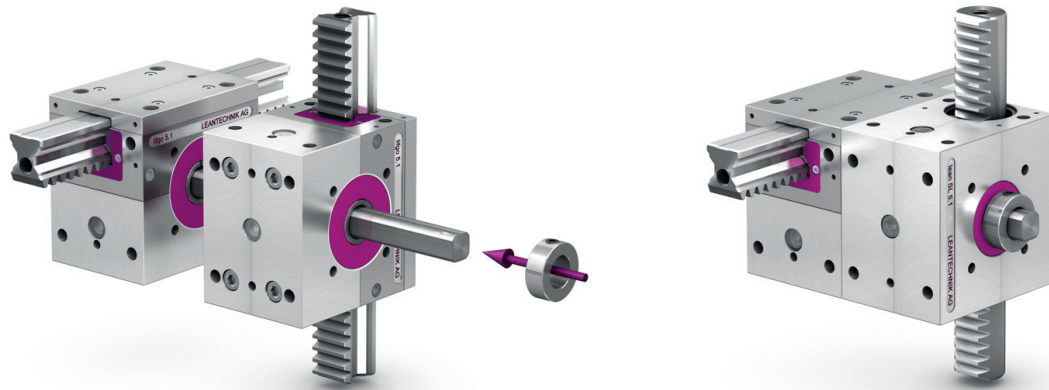

Flexibility thanks to four pinion shaft designs

All our gearboxes are available with four pinion shaft designs. Alongside the standard profile shaft variant (PW), we can also supply versions with one pin (ZA 1), two pins (ZA 2) or with a keyway (PFN). Their dimensions differ depending on the size of the corresponding model.

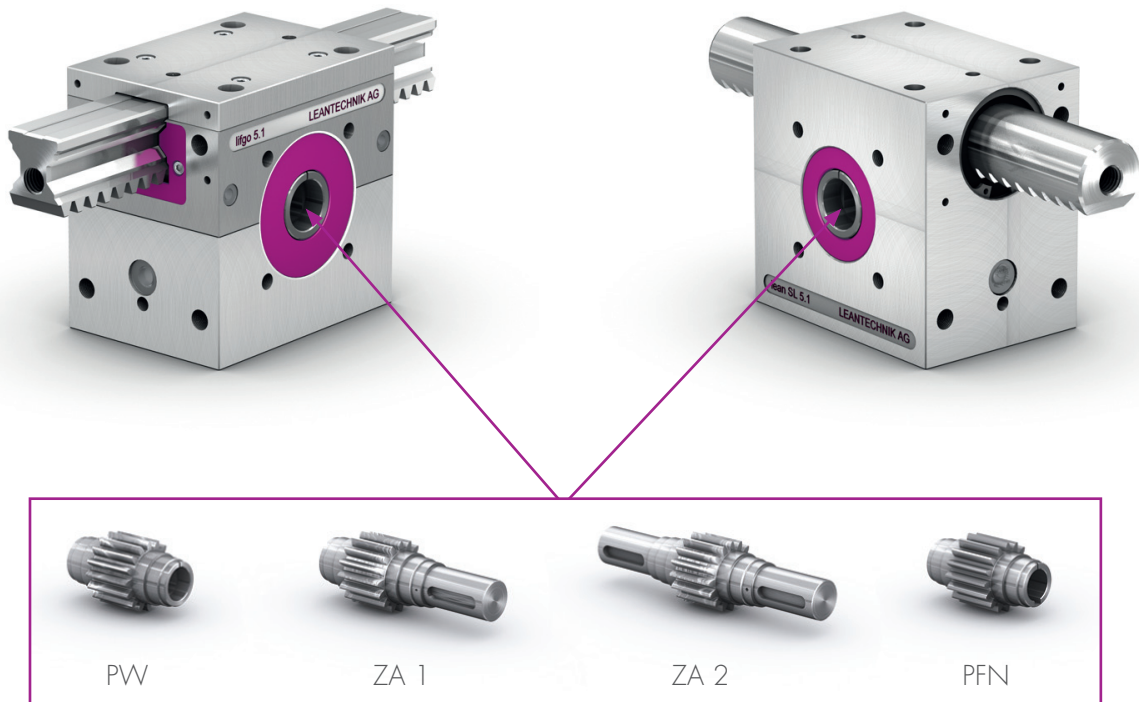

Accessories

The systematic modular construction of our lifgo® and lean SL® series means that only a small number of accessories are needed. The entire range of accessories has been further simplified in the 5th generation of components. All the parts are perfectly harmonized for interoperation and therefore help cut your project costs.

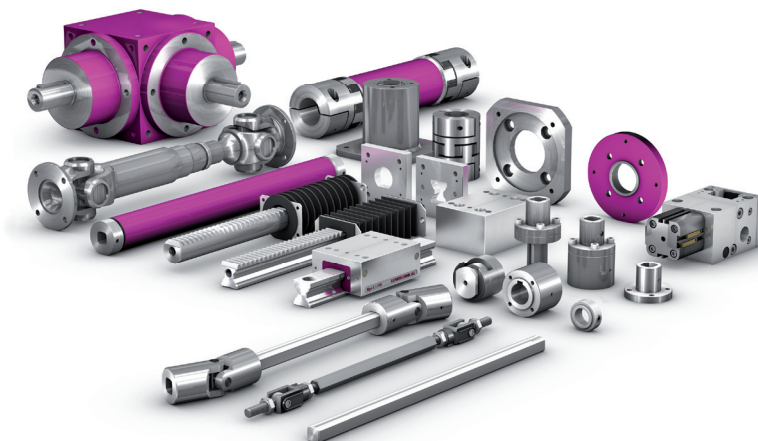

Mechanical arrest system (ASS)

The mechanical arrest system (ASS) is a device that can be mounted on the gearboxes to prevent the uncontrolled descent of installations, installation components or heavy items and counter the effect of applied forces.

It makes it possible to ensure that systems, machines or equipment do not descend suddenly or collapse during inspections or repair work. The secured force is 5 times greater than the nominal force of the associated lifgo® or lean SL® gearbox.

When used in combination with lifgo® or lean SL® gearboxes, the ASS can also be used as a positioning unit for a given value.

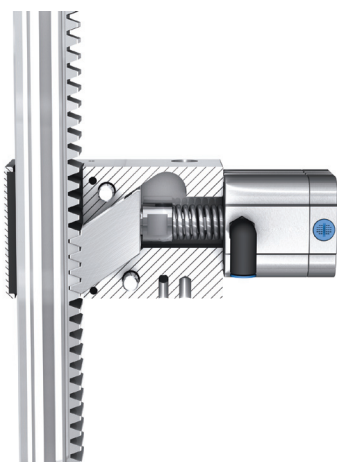

Mechanical arrest system locked

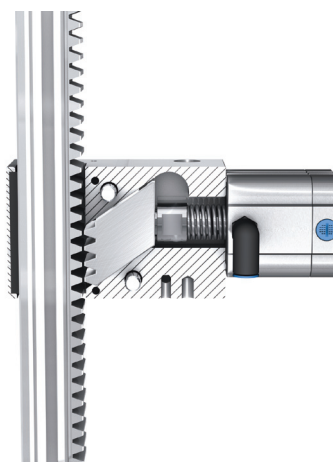

Mechanical arrest system unlocked

Lifting systems

By way of example, we indicate some of the applications that are possible using our lifgo® & lean SL® series of gearboxes below.

lifgo®-lifting system 1 | An electrical drive is used for synchronous vertical and horizontal lifting motions.



lifgo®-lifting system 2 | The distributor gearbox ensures that the gearboxes are synchronized with one another. The electrical gearbox motor can be seen in the middle.

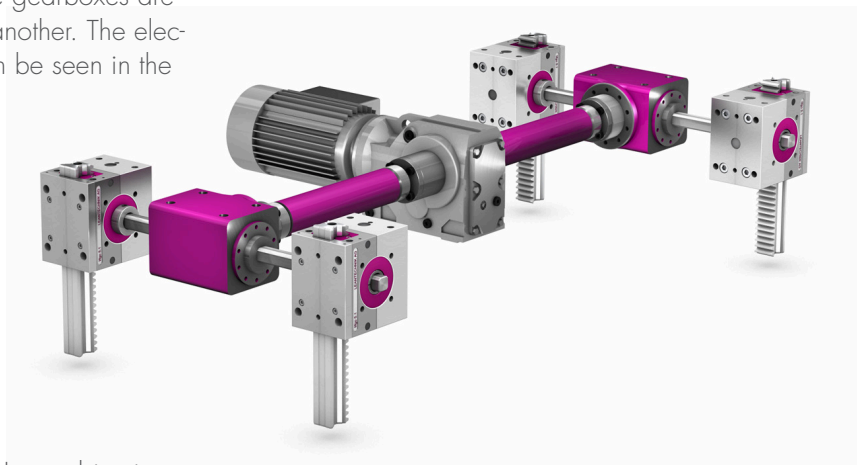

lifgo®-lifting system 3 | In combination with the electrical gearbox motor, the external distributor gearbox ensures that the gearboxes are synchronized with one another. The assembly space in the centre remains available.

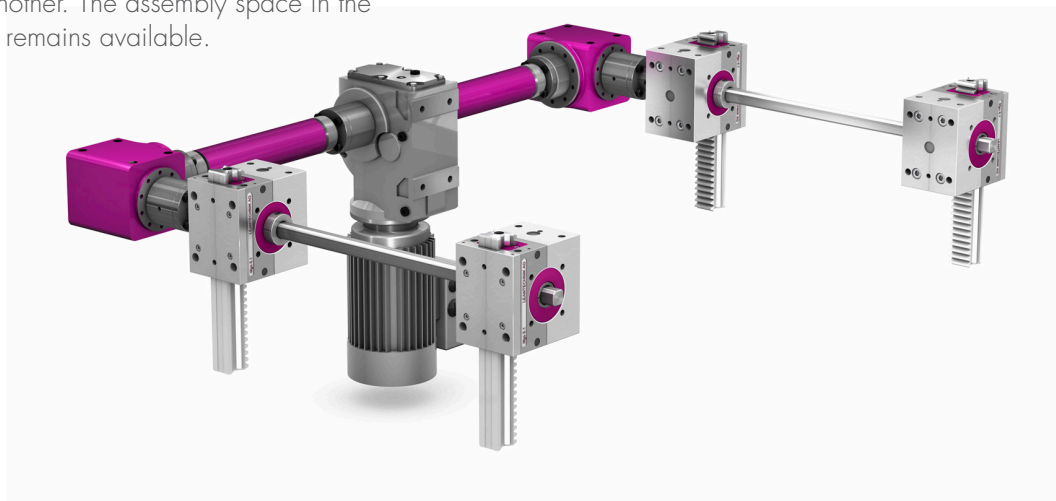

leantranspo® – partial and complete functional systems

We market our partial and complete functional systems under the name leantranspo®. Below you will find some example systems. There are so many individually designed systems based on components from the lifgo® and/or lean SL® series that we can only present a small selection here. You will find many other possible combinations in our full catalog or on the Internet at www.leantechnik.com.

„Pick and place“-system | The system operates extremely quickly and accurately and is mounted on a longitudinal beam. Here, both the long, horizontal and short, vertical stroke are performed using the lifgo® linear.

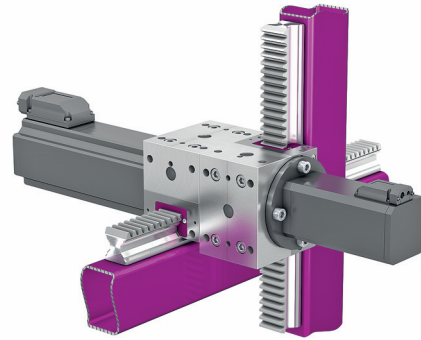

3-axis positioning system (DAP) | Flexible spatial movement thanks to lifgo® gear-box controlling 3 axes. Components are picked up and clamped at the top end of the Z-axis. The system is able to support transverse forces and process forces. It is suitable for use, for example, in production lines in the automotive industry. The DAP makes it possible to manufacture chassis frames of different sizes and shapes on one and the same production line. To do this, the distances between the pick-up points are adapted automatically for each chassis frame.

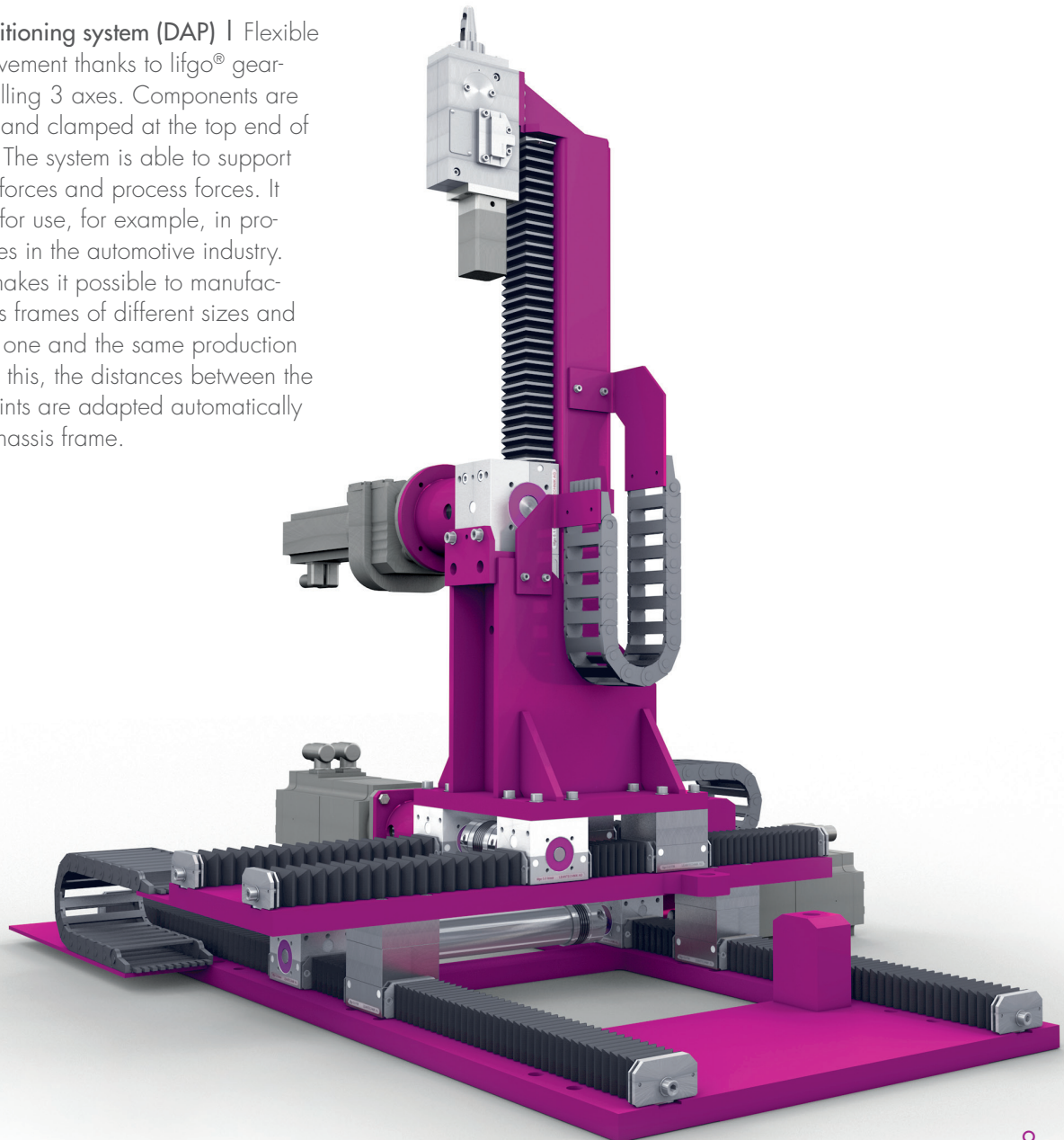



leantranspo® | Plant construction

leantranspo®-lift columns

Both variants operate quickly, precisely and with a high level of repeat accuracy. All the parameters can be selected individually.



Lifting column 1 | System for large loads with two lifting gear racks operating in parallel.

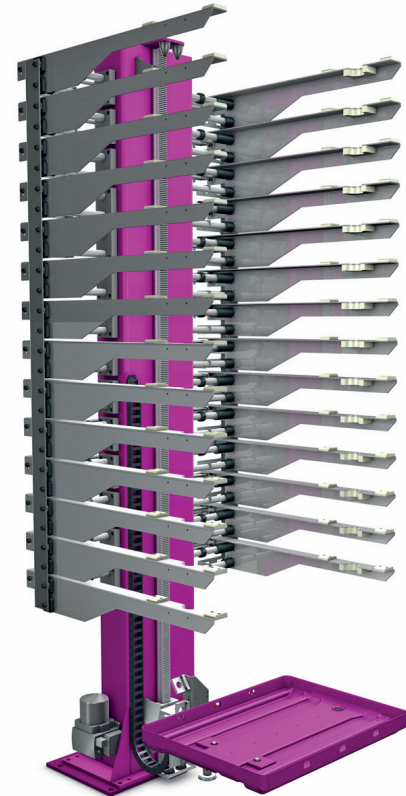

Lifting column 2 | System for intermediate stacking with additional features such as central lubrication and auxiliary guides.

leantranspo®-lifting systems

lifgo®-lift table | Lift table with 2 identical lifting columns, driven by 2 electrical motors, master/slave synchronization. In this example, the lift table is illustrated with a roller conveyor. However, other pick-up capabilities can also be used. The system makes it possible both to pick up heavy items and operate at high speeds.

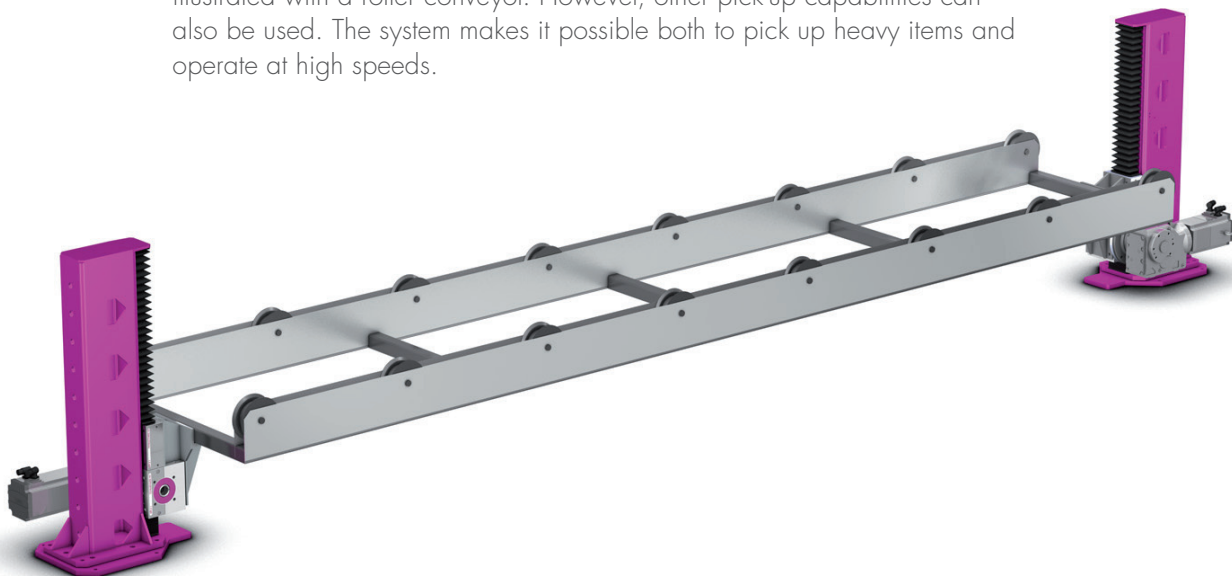

leantranspo®-large-scale system

On request, we can supply large-scale systems based on our lifigo® and/or lean SL® series ready-for-operation and including controller and assembly. When configuring customized complete systems, we may sometimes also use production components sourced from other manufacturers.

lifigo®-gantry system | This system uses lifigo®, lifigo® linear and lifigo® double in a complex combination consisting of a palletizer and feed mechanism with 3-axis gripper arm and 2-axis palletizer. The movements of the two arms are synchronized with one another. The 3-axis gripper arm takes the blanks from the left-hand stack, places them on the conveyor and returns a finished part to the blister pack. The 2-axis palletizer moves the blister pack to the three different positions.

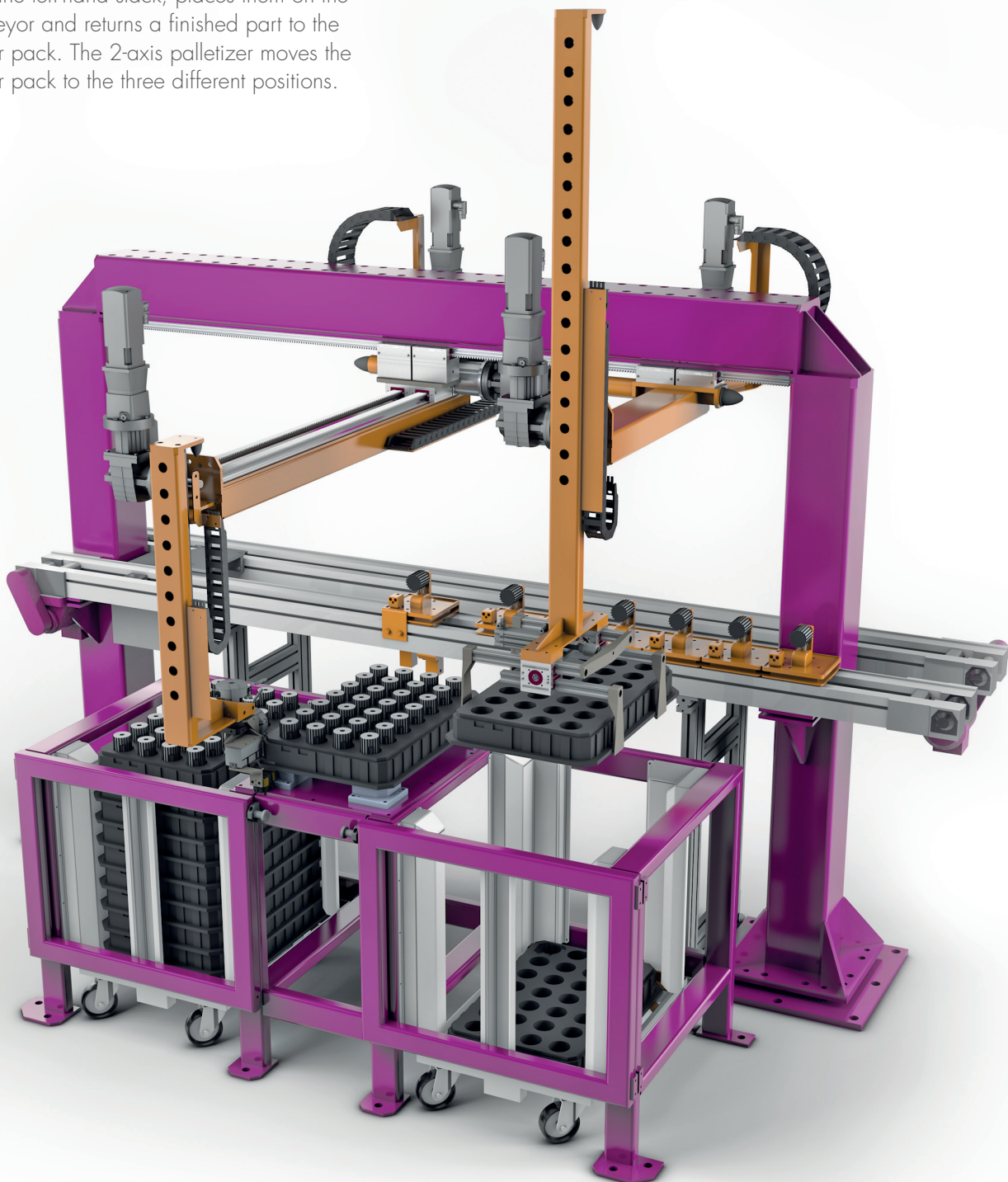

lifgo® & lean SL® | Technical data

lifgo®			5.0	5.1	5.3
Lifting force	F_{max}	N	2000	3800	15900
Lifting speed	v_{max}	m/s	3	3	3
Acceleration	a_{max}	m/s^2	50	50	50
Torque	M_{max}	Nm	20	76	477
Efficiency	η		0,92	0,92	0,92

lean SL®			SL 5.0	SL 5.1	SL 5.3
Lifting force	F_{max}	N	800	2000	8000
Lifting speed	v_{max}	m/s	0,6	0,6	0,6
Acceleration	a_{max}	m/s^2	30	30	30
Torque	M_{max}	Nm	8	40	240
Efficiency	η		0,8	0,8	0,8

The complete technical data for the overall system can be found in our full catalog. We will be delighted to send this to you on request.

At www.leantechnik.com, you will find extensive additional information as well as a large range of **videos**. The Download section contains our catalog together with 2D/3D data in various CAD formats.

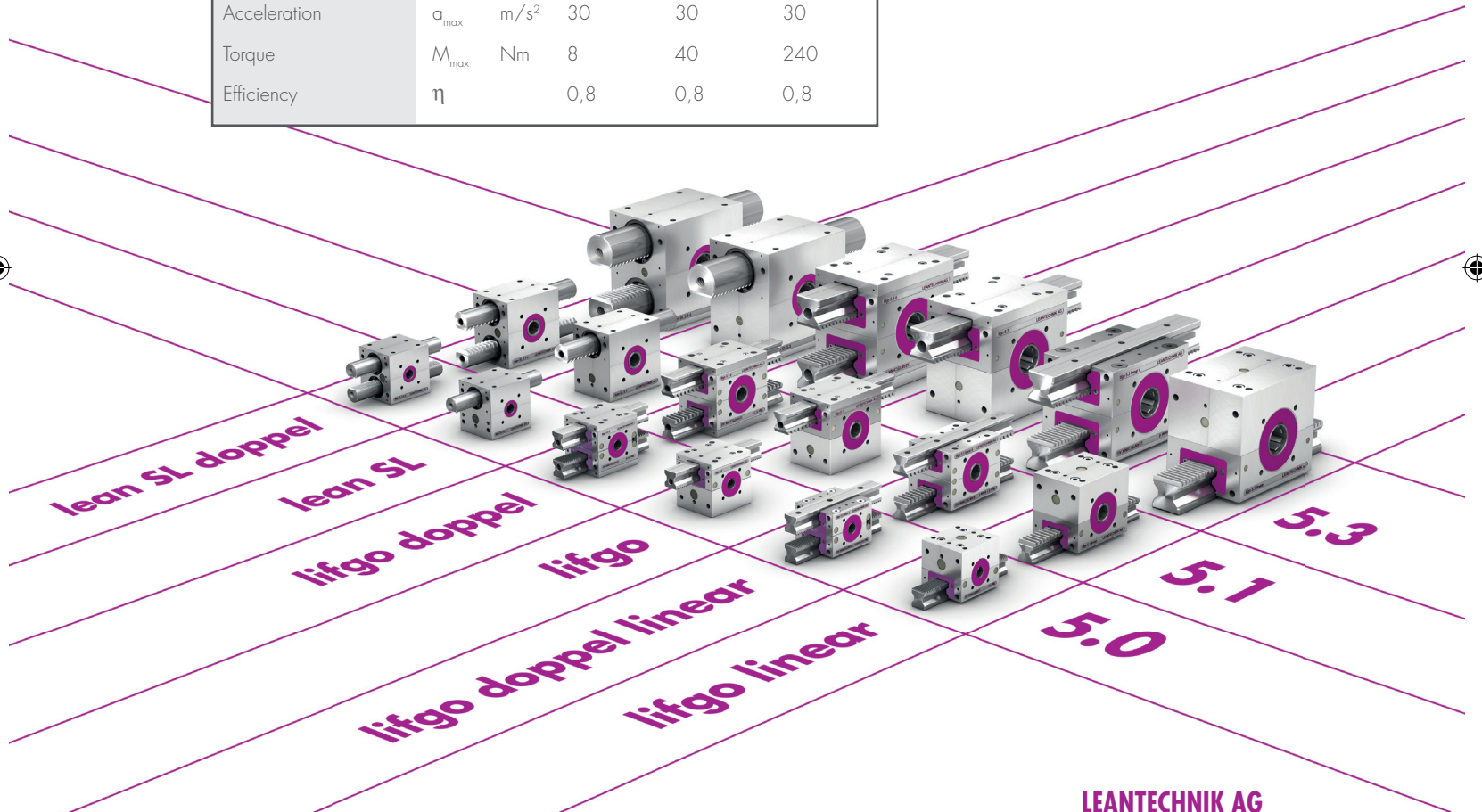

LEANTECHNIK AG

Im Lipperfeld 7c
46047 Oberhausen
Germany

Phone ..49 (0) 208 · 495 25 - 0
Fax ..49 (0) 208 · 495 25 -18

E-mail info@leantechnik.com

www.leantechnik.com

Quality Management Certification in accordance with DIN EN ISO 9001
Registration no. 254883 QM ff