

## User Manual

# Ethernet to Wireless Client Adaptor, PC-W



***BrainChild***

Brainchild Electronic Co., Ltd.

UMPCWA, 06/2009

## **Important Announcement**

The information contained in this document is the property of Brainchild Electronic and is supplied for the sole purpose of operation and maintenance of products of Brainchild Electronic. No part of this publication is to be used for any other purposes, and it is not to be reproduced, copied, disclosed, transmitted, stored in a retrieval system, or translated into any human or computer language, in any form, by any means, in whole or in part, without the prior explicit written consent of Brainchild Electronic

### **Brainchild Electronic Co. Ltd**

**6F, No.209, Chung Yang Rd, Nankang Dist**

**Taipei, Taiwan, R.O.C**

**Tel: 886-2-27861299, Fax: 886-2-27861395**

**Email: [sales@brainchild.com.tw](mailto:sales@brainchild.com.tw)**

**Website: <http://www.brainchild.com.tw>**

Copyright © 2009 Brainchild Electronic. All rights reserved

All other product names referenced herein are registered trademarks of their respective companies.

# FCC WARNING

## Class A for this product

This product has been tested and found to comply with the limits for a Class A digital device, pursuant to Part 15 of the FCC Rules. These limits are designed to provide reasonable protection against harmful interference in a residential installation. This equipment generates uses and can radiate radio frequency energy and, if not installed and used in accordance with the instructions, may cause harmful interference to radio communications. However, there is no guarantee that interference will not occur in a particular installation. If this equipment does cause harmful interference to radio or television reception, which can be determined by turning the equipment off and on, the user is encouraged to try to correct the interference by one of the following measures:

- Reorient or relocate the receiving antenna.
- Increase the separation between the equipment and receiver.
- Connect the equipment into an outlet on a circuit different from that to which the receiver is connected.
- Consult the dealer or an experienced radio/TV technician for help.

This product complies with Part 15 of the FCC Rules. Operation is subject to the following two conditions: (1) This device may not cause harmful interference, and (2) this device must accept any interference received, including interference that may cause undesired operation.

**FCC Caution: Any changes or modifications not expressly approved by the party responsible for compliance could void the user's authority to operate this equipment.**

## IMPORTANT NOTE:

### FCC Radiation Exposure Statement:

This product complies with FCC radiation exposure limits set forth for an uncontrolled environment. This model should be installed and operated with minimum distance 20cm between the radiator & your body.

This transmitter must not be co-located or operating in conjunction with any other antenna or transmitter. IEEE 802.11b/g operation of this product in the U.S.A. is firmware-limited to channels 1 through 11.

### UL Notice for Power supplier

All the series of PC-W products are intended to be supplied by a Listed Power Unit marked with "LPS", "Limited Power Source" or "Class 2" and output rate 9~48VDC, 1.0A minimum. Or, use the recommended power supply in "Optional Accessories".

# Contents

<b>1. INTRODUCTION .....</b>	<b>6</b>
1.1. OVERVIEW .....	6
1.2. FEATURES .....	6
<b>2. GETTING STARTED .....</b>	<b>7</b>
2.1. PACKAGING INCLUDE .....	7
2.2. ORDERING INFORMATION .....	7
2.3. INTERFACES .....	7
2.4. INSTALLATION PROCEDURES .....	8
<b>3. SOFTWARE SETUP .....</b>	<b>8</b>
3.1. DEFAULT SETTINGS .....	8
3.2. IP ASSIGNMENT .....	9
3.2.1. <i>Configure IP by Serial Manager Utility</i> .....	9
3.2.2. <i>Configure IP address using ARP commands</i> .....	9
3.2.3. <i>Configure IP Using Web Interface</i> .....	10
3.2.4. <i>Automatic IP address assignment using DHCP</i> .....	10
3.3. TCP/IP PORT NUMBER .....	10
<b>4. APPLICATION CONNECTIVITY .....</b>	<b>11</b>
4.1. TCP & UDP PROTOCOLS .....	11
4.1.1. <i>Transmission Control Protocol (TCP)</i> .....	11
4.1.2. <i>User Datagram Protocol (UDP)</i> .....	11
4.2. CONNECTIVITY TOPOLOGY .....	11
4.3. ETHERNET TO WLAN BRIDGE FUNCTION .....	12
4.4. VIRTUAL COM MODE .....	12
4.4.1. <i>TCP Server in Virtual COM Mode</i> .....	12
4.4.2. <i>TCP Client in Virtual COM Mode</i> .....	12
4.5. TUNNELING MODE .....	13
4.6. UDP MODE .....	14
<b>5. CONFIGURE PC-W BY WEB INTERFACE.....</b>	<b>16</b>
5.1. LOGIN TO SYSTEM .....	16
5.2. GENERAL INFORMATION .....	16
5.2.1. <i>Device Information</i> .....	18
5.2.2. <i>Wireless Client Adaptor Information</i> .....	18
5.2.3. <i>Serial Information</i> .....	19
5.3. NETWORK CONFIGURATIONS .....	19
5.3.1. <i>Wireless Client Adaptor Settings</i> .....	20
5.3.2. <i>DNS Settings</i> .....	21
5.3.3. <i>SNMP Settings</i> .....	21
5.4. WIRELESS CONFIGURATION .....	22
5.4.1. <i>Wireless Settings</i> .....	23
5.4.2. <i>Sample Wireless Application Cases</i> .....	23
5.5. COM PORT CONFIGURATION .....	25
5.5.1. <i>TCP Server Mode</i> .....	25

5.5.2.	<i>TCP Client Mode</i> .....	25
5.5.3.	<i>UDP Mode</i> .....	27
5.5.4.	<i>Serial Settings</i> .....	27
5.5.5.	<i>Packet delimiter</i> .....	28
5.6.	CONFIGURE SYSTEM .....	28
5.6.1.	<i>Configure Time by NTP Service</i> .....	28
5.6.2.	<i>WLAN Region</i> .....	29
5.6.3.	<i>Security (Password Change)</i> .....	29
5.6.4.	<i>Restoring Factory Default Configurations</i> .....	30
5.6.5.	<i>Restart System</i> .....	30
5.7.	APPLICATIONS .....	31
5.7.1.	<i>Paperless Recorder VR18 (Ethernet port) to Wireless Ethernet</i> .....	31
5.7.2.	<i>Paperless Recorder VR18 (Serial port) to Wireless Ethernet</i> .....	37
5.7.3.	<i>Paperless Recorder VR18 to PC via Wireless Ethernet (Using 2 PC-W devices)</i> .....	46
<b>APPENDIX A.</b>	<b>USING VIRTUAL COM</b> .....	<b>48</b>
A.1.	PRE-INSTALLATION REQUIREMENTS .....	48
A.2.	LIMITATION AND INSTALLATION .....	48
A.3.	VIRTUAL COM COMMUNICATION .....	49
<b>APPENDIX B.</b>	<b>CONFIGURATION UTILITY</b> .....	<b>52</b>
B.1.	SERIAL MANAGER UTILITY INTRODUCTION .....	52
B.2.	INTERFACE .....	52
B.3.	FUNCTIONS .....	52
B.3.1.	<i>Device Search</i> .....	52
B.3.2.	<i>Firmware</i> .....	54
B.3.3.	<i>Configuration</i> .....	56
B.3.4.	<i>Security</i> .....	57
B.3.5.	<i>View</i> .....	58
B.3.6.	<i>About</i> .....	58
<b>APPENDIX C.</b>	<b>UPGRADING SYSTEM SOFTWARE</b> .....	<b>58</b>
<b>APPENDIX D.</b>	<b>SPECIFICATIONS</b> .....	<b>59</b>
D.1.	HARDWARE SPECIFICATIONS .....	59
D.2.	SOFTWARE SPECIFICATIONS .....	60
D.3.	PIN ASSIGNMENTS .....	60
D.3.1.	<i>DB9 male connector pin assignments for Serial port</i> .....	60
D.4.	BEEP & LED STATUS .....	60
D.4.1.	<i>Startup status</i> .....	60
D.4.2.	<i>Wireless Signal Strength status</i> .....	61
D.4.3.	<i>WLAN LED Message</i> .....	61
D.4.4.	<i>COM Port LED Message</i> .....	61
D.4.5.	<i>RUN LED Message</i> .....	61

# 1. Introduction

## 1.1. Overview

PC-W Wireless Client Adaptor is a bridge between RS-232, RS422, RS-485, Ethernet based devices and wireless LAN. It allows almost any Ethernet and serial devices to be connected to a new or existing wireless network. The information transmitted by Wireless Client Adaptor is transparent to both host computers (IP network over wireless LAN) and devices (Ethernet/RS-232/RS-422/ RS-485). Data from the wireless LAN is transmitted to the designated Ethernet/ RS-232/ RS-422/ RS-485 port and data from Ethernet/ RS-232/ RS-422/ RS-485 port is transmitted to the Wireless (TCP/IP) transparently.

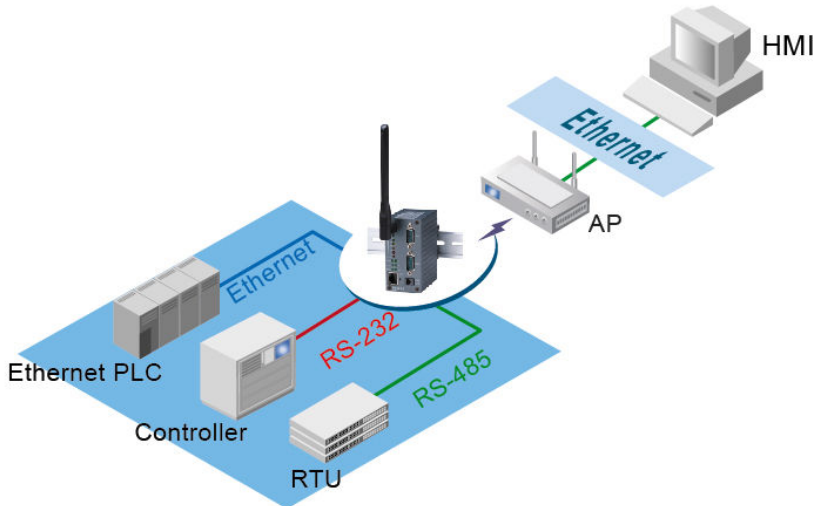

In the computer integration manufacturing or industrial automation area, Wireless Client Adaptor is used for field devices to direct connect to network.

Many control devices provide the ability to communicate with hosts through Ethernet/RS-232/RS-485 however RS-232/RS-485 serial communication has its limitations. For instance, it is hard to transfer data through Wireless or long distance. With PC-W, it is possible to communicate with a remote device in the Intranet environment and thus, increases the communication distance dramatically.

Flexible configuration options enable this unit to be setup remotely over IP network by Web browser, or Window utility. Packed in a rugged DIN Rail mountable case and 9~48V DC power input range, PC-W is ideal for almost any industrial and manufacturing automation.

## 1.2. Features

### Features

- 2 Nos. serial ports
- Selectable RS-232/RS-485/RS-422 serial mode by software
- Transparent between Ethernet to Wireless networking
- Support UDP, TCP server and client protocols for Virtual COM mode and pair connection
- Configurable via built-in web server and Windows-based utilities
- Metal housing and IP50 standard with DIN-Rail mounting.
- 15KV ESD protection for serial ports
- IEEE 802.11g 54Mbps wireless network connectivity
- Standard 2.4GHz High-gain antenna

## 2. Getting Started

### 2.1. Packaging Include

- PC-W Wireless Client Adaptor x 1
- 4 dBi Antenna x 1
- Wall mount kits x 2
- PC-W Wireless Client Adaptor quick start guide x 1
- Product CD containing configuration utility x 1

**NOTE: Notify your sales representative if any of the above items is missing or damaged.**

### 2.2. Ordering information

The PC-W can be ordered using the following codes.

<b>PC-W</b>	Wireless Client Adaptor plus 2-ports with D-Sub 9pin serial connector
-------------	---

Optional Accessories and their ordering codes

<b>AH1812-B</b>	AC100~240V US plug / DC12V DC – Jack, Power adapter
<b>AH1812-E</b>	AC100~240V EU plug / DC12V DC- Jack, Power adapter
<b>1GP-2409</b>	9.0 dBi Omni directional antenna, N female connector (Max. line of sight distance: 800 mtr)
<b>1PG-24001</b>	9.0 dBi directional panel antenna
<b>1CB-0025</b>	External RF Cable, RG58 SMA to N Male 3 m to be used with antenna

### 2.3. Interfaces

The interfaces of PC-W on the front panel are shown in Fig. 1.

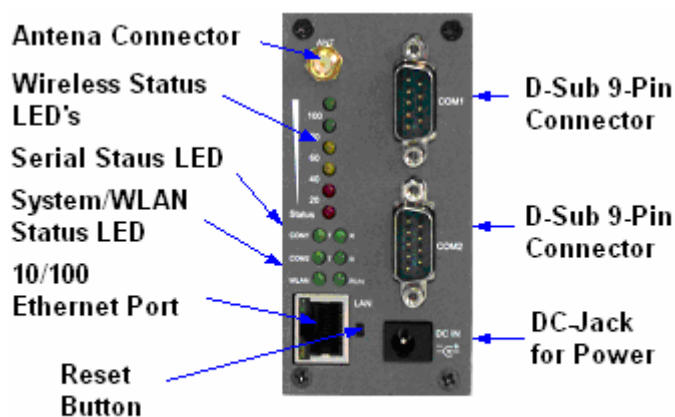

DB Model (9 pin D-Sub Connectors)

**Fig. 1. PC-W Front Panel and Interfaces**

## 2.4. Installation Procedures

- Prepare necessary cables, DC power adaptor and RS-232/RS-485 connector.
- Install Serial Manager software in your PC from Product CD
- Place PC-W under the access point signal coverage area. Connect PC-W to your PC via Ethernet using RJ45 connector.
- If you wish to connect serial device to PC-W, connect it. Please make sure the connector and wiring of RS-232 or RS422 or RS-485 is correct. If you just wish to connect Ethernet device to PC-W, then first complete checking of PC-W status from Computer, then connect Ethernet device to PC-W
- Plug in PC-W to DC-9-48V power source (with DC-jack), buzzer will beep and the RUN LED will blink if PC-W functions normally. For LED Status see Appendix D.4

Use **Serial Manager**, configuration utility to check the status of PC-W. If it starts up successfully, users shall find the IP and MAC addresses of PC-W. Users can also change IP address, gateway IP address and subnet mask networking parameters of PC-W according to user networking configurations.

## 3. Software Setup

Now the PC-W hardware is installed and the power is on, network IP configuration will be set in this section.

### 3.1. Default Settings

The PC-W has two IP addresses one for Ethernet interface and another one for wireless network interface. These default settings are shown below

Property	Default Value
<b>Wireless Client Adaptor IP</b>	
IP Address	10.0.50.100
Gateway	10.0.0.254
Subnet Mask	255.255.0.0
<b>Security</b>	
User Name	Admin
Password	Null (Leave it blank)
<b>Serial</b>	
COM	9600/None/ 8/1, No flow control, packet delimiter disabled
Link Mode	TCP Server, Listen port 4660/4661, No Filter, Virtual COM disabled
<b>SNMP</b>	
SysName of SNMP	Name
SysLocation of SNMP	Location
SysContact of SNMP	Contact

**Table 1. Factory default settings of the PC-W**

**Reset procedure:** Push Reset button for 5 seconds and then release to restart PC-W with the factory default settings.

**Warning:** Please avoid setting LAN and WLAN IP addresses in the same subnet. This may create unexpected networking problems.



## 3.2. IP Assignment

### 3.2.1. Configure IP by Serial Manager Utility

Use **Serial Manager**, configuration utility that comes with Product CD-ROM to configure the network parameters. For more details, please refer to Appendix B1.

Find a new device and IP assignment

- Use **Serial Manager Utility** to find the new device IP address or to get the device's current IP address as shown in Fig. 2.
- If needed, use **Serial Manager Utility** to re-assign a new IP address, Network Mask and Gateway address to the new device.
- Users can also configure User ID, Password and Host Name using **Serial Manager Utility**.

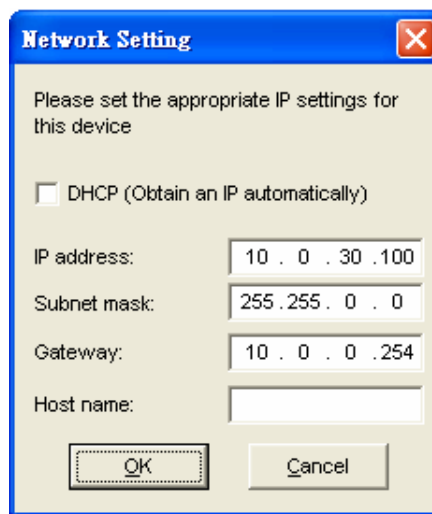

Fig. 2. IP Settings using Serial Manager Utility software

Note: All settings will NOT be changed if User ID or Password was incorrect.

If there is more than one device using the same IP address in the same subnet, users need to correct the mapping between MAC address and IP address using ARP commands as explained in the next section.

### 3.2.2. Configure IP address using ARP commands

ARP (Address Resolution Protocol) commands can be used to assign a static IP address on PC-W using its hardware MAC (Media Access Control) address. The MAC address "0060E9-xxxxxx" is printed on the rear side of PC-W. The following procedure show how to use ARP commands on MS-DOS Command Prompt Window

**Example:** Set the IP address 10.0.50.101 to the MAC address 00-60-E9-00-79-F8

```
C:\> arp -s 10.0.50.101 00-60-E9-00-79-F8
```

**arp -a** command shows the current mapping IP and MAC addresses

**arp -s** "IP address" "MAC address" maps the IP address to a specific MAC address

**Note:** ARP commands can only be used to set a static IP address of PC-W

```

C:\WINDOWS\system32\command.com
C:\DOCUMENTS\ADMINI~1>arp -s 10.0.50.101 00-60-E9-00-79-F8
C:\DOCUMENTS\ADMINI~1>arp -a

Interface: 0.0.0.0 --- 0x4
Internet Address      Physical Address      Type
10.0.50.101           00-60-e9-00-79-f8    static

Interface: 192.168.25.71 --- 0x5
Internet Address      Physical Address      Type
192.168.25.40         00-19-66-0b-6e-89    dynamic
192.168.25.186        00-60-e9-01-8c-bb    dynamic
192.168.25.254        00-19-66-0b-6a-dc    dynamic

C:\DOCUMENTS\ADMINI~1>_

```

Fig. 3. Mapping IP address to MAC address using ARP Command

### 3.2.3. Configure IP Using Web Interface

Use common web browsers, e.g. Microsoft Internet Explorer or Mozilla Firefox, to configure the network parameters of PC-W.

- Open a Web browser, type in the **IP address** (default IP: 10.0.50.100) of the PC-W to be configured. The default user name is **admin** and the default password is **null** (leave it blank).
- From the Web **Network links page**, please configure IP address, subnet mask, and gateway address, and then click “**Save Configuration**” to save all settings.
- Click **Restart** button to reboot the device to make the changes effective.

Please refer to contents of Web Configuration section for more details of the settings.

### 3.2.4. Automatic IP address assignment using DHCP

DHCP server can automatically supply an IP address, gateway address, and subnet mask to PC-W device if its DHCP client function is enabled. By default, the DHCP client function is disabled, users can activate the DHCP function by following these steps

- Execute **Serial Manager Utility**
- Click on the **IP address** of PC-W (This can be the default IP address if it was never set before).
- Click **Config** to pop-up the static IP Dialog Window.
- Check on **Auto IP**
- Click **Config Now**. (The PC-W will restart and obtain an IP from DHCP server automatically)

**Note: You need to have a DHCP Server running in your subnet to automatically supply an IP address. Please consult your network administrator if you are not sure.**

### 3.3. TCP/IP Port Number

Default TCP Port numbers of PC-W are **4660** (1st port) and **4661** (2nd Port) that are associated with the Serial port **COM1** and **COM2**, respectively. After the application program connects to the TCP port 4660 (or 4661) on the PC-W, data of user’s application program are transparently transmitted to Serial port COM1 (or COM2) of PC-W.

## 4. Application Connectivity

The PC-W is designed to transmit data between one or more Ethernet/serial devices to/from one or more TCP/IP devices through wireless Ethernet interface. PC-W can enhance the accessibility of the serial device through TCP/IP based Ethernet as well as Wireless Ethernet. The connection distance limit is overcome by PC-W. Examples of these devices are PLC controllers, card readers, display signs, security controls, CNC controller, etc.

### 4.1. TCP & UDP Protocols

PC-W can operate in two most common transportation protocols, TCP and UDP.

#### 4.1.1. Transmission Control Protocol (TCP)

TCP provides a connection and a byte oriented data stream with control parameters such as flow control, multiple ports option, and order delivery notification. Once the connection is established, data can be transmitted in both directions. TCP guarantees data is transmitted from one node to the other node(s) in orderly. The protocol also distinguishes the transmitted data for different applications (such as a Web server or an Email server) on the same computer.

For redundant or dual-network connectivity purposes, PC-W offers two TCP operation modes so users may choose for their specific application, TCP Server Mode and TCP Client Mode.

#### 4.1.2. User Datagram Protocol (UDP)

UDP is a faster datagram delivery protocol. User can configure PC-W to work in the UDP mode. UDP is connectionless protocol and can transmit multicast data to/from a serial device to one/multiple host computer. Because UDP is the connectionless protocol, UDP does not guarantee the reliability and orderly data streams like TCP protocol. Datagram may arrive out of order or lose without notice. But the advantage of UDP is the speed. UDP is faster and hence more attractive in time-sensitive applications.

## 4.2. Connectivity Topology

PC-W is also equipped with Tunneling and Virtual COM operation modes. It is designed to transmit data to/from multiple serial devices and from/to multiple TCP/IP devices on Ethernet, so it can enhance the accessibility of the serial devices immensely. The example of PC-W connection topology is shown in Fig. 4.

**Note: Please do not connect more than one device on Ethernet port**

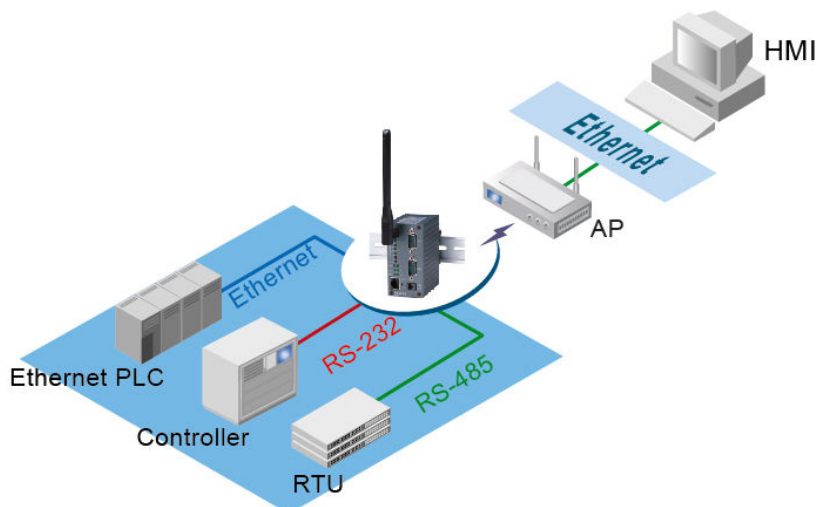

Fig. 4. Typical Topology of PC-W Connection

### 4.3. Ethernet to WLAN Bridge Function

The PC-W can also work as a network bridge between Ethernet to WLAN. Packets from WLAN to Ethernet or from Ethernet to WLAN are transferred transparently. This will let the Ethernet devices can be accessed from wireless networks over the wireless interface.

### 4.4. Virtual COM Mode

The **Virtual COM** software emulates a serial port in LAN topology. In the Virtual COM Mode, COM port data is encapsulated with Ethernet data format. By creating a virtual COM port on a PC, the Virtual COM driver redirects communications from the virtual COM port to the destination IP address (and the designated port number) by encapsulating COM data into IP packet format. **Fig. 5** illustrates a Virtual COM connection diagram.

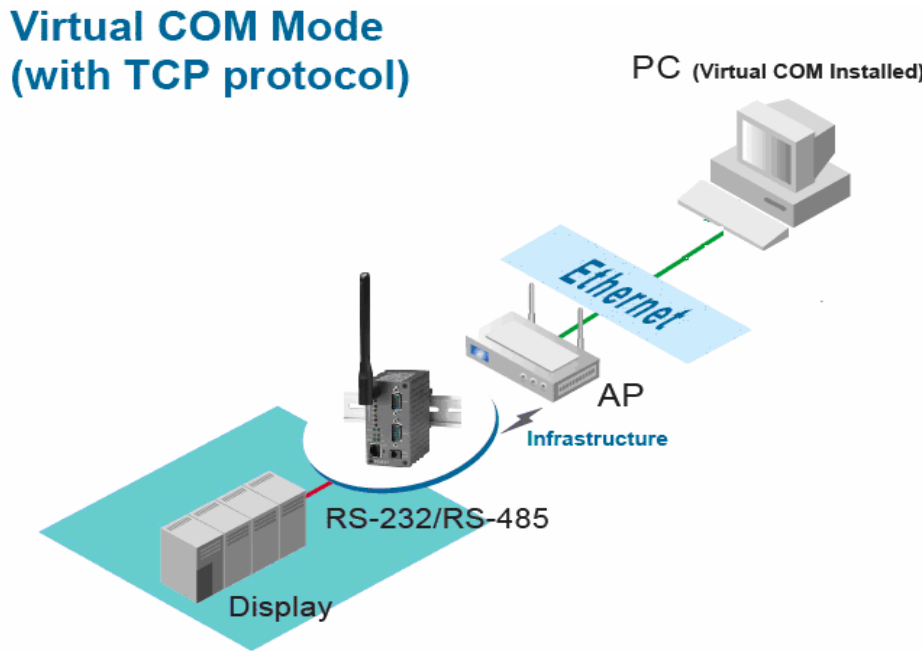

**Fig. 5. TCP Connection in Virtual COM Mode**

#### 4.4.1. TCP Server in Virtual COM Mode

PC-W can be configured in the TCP server mode (PC acts as a client) with a unique IP and Port number, and PC-W waits passively for the PC to establish a connection. After the connection is established, PC can communicate to serial devices through PC-W.

#### Configure PC-W to be TCP server

Using one of the two configuration methods, by Web-based and by Windows-based **Serial Manager** utility, Users can configure PC-W to be a TCP Server as follows.

- Disabled the IP filter (default)
- Set the port number (default port is 4660 for COM1, 4661 for COM2).
- If IP filter is enabled, only the assigned source IP is allowed to be connected to PC-W.

#### 4.4.2. TCP Client in Virtual COM Mode

PC-W can also be configured in TCP Client mode (PC as a server) to establish a TCP connection to an application server on PC, or the Remote Control Host. Once the connection is established, PC or Remote Control Host can exchange data with several serial devices at the same time through PC-W as shown in Fig. 6.

## Configuring PC-W to be TCP client

User can configure PC-W to be as a TCP client, for example, from Fig. 7, PC, as a server, has IP address 10.0.0.100 and listening on port 1000. Each PC-W, connected with serial device, configured as TCP client mode with destination IP address 10.0.0.100 and the destination port 1000, and the IP filter is disabled (by default).

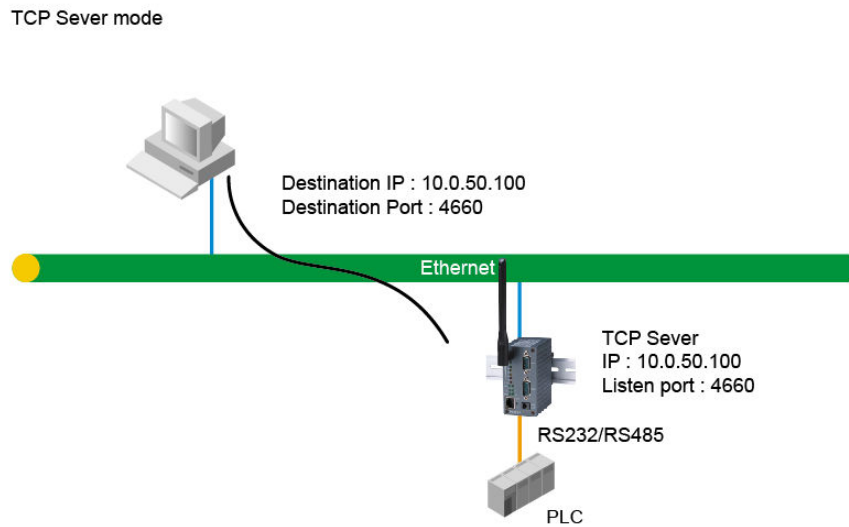

Fig. 6. TCP Server in Virtual COM Mode

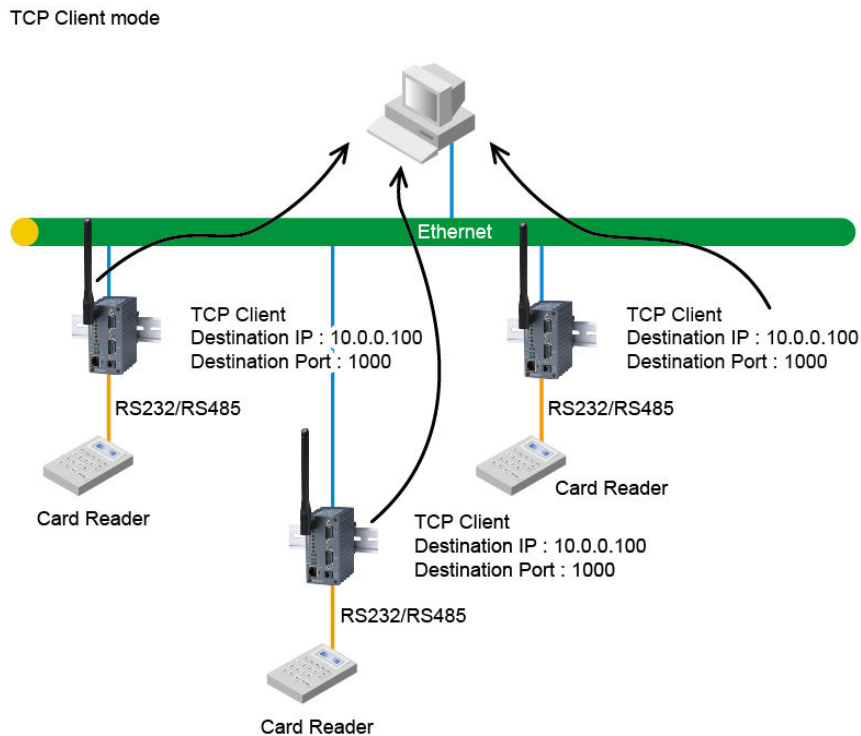

Fig. 7. TCP Client in Virtual COM Mode

## 4.5. Tunneling Mode

Tunneling Mode is used for multiple serial devices to “talk” among one another through PC-W’s wireless LAN or wired Ethernet interface. This mode is particularly useful when two or more serial devices are far away. This mode can be used to extend the normal RS-232 serial communication distance of 15 m to 100 m or longer as shown in Fig. 8.

One PC-W can be configured to be the TCP Server Mode with serial device connected and also another PC-W is configured as TCP client with serial device connected. After the connection is established, both serial devices can exchange data to each other transparently. For example, users can implement PC-W tunneling mode for Master /Slave mode PLC's or between other serial devices.

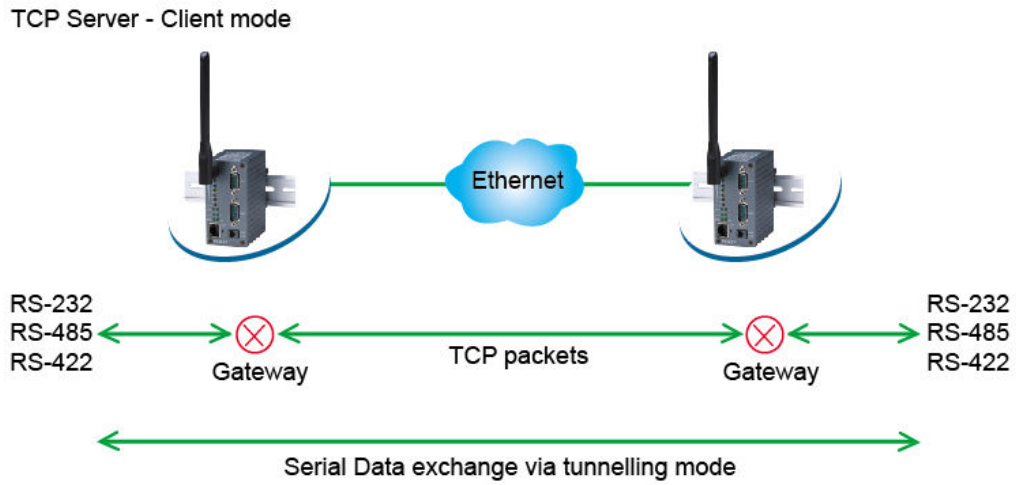

Fig. 8. TCP Link in Tunneling mode

### Configuring PC-W to Tunneling Mode

Using one of two configuration methods (Web-based or Windows-based **Serial Manager** utility), users can configure PC-W to TCP Server mode with a desired IP address and port, and with other PC-W is configured as TCP Clients mode with Server IP and port as destination IP and port respectively as shown as an example in Fig. 9.

**Note: TCP client has to assign the destination IP and the destination port corresponding to TCP server's IP and listening port (example: TCP 4660 port).**

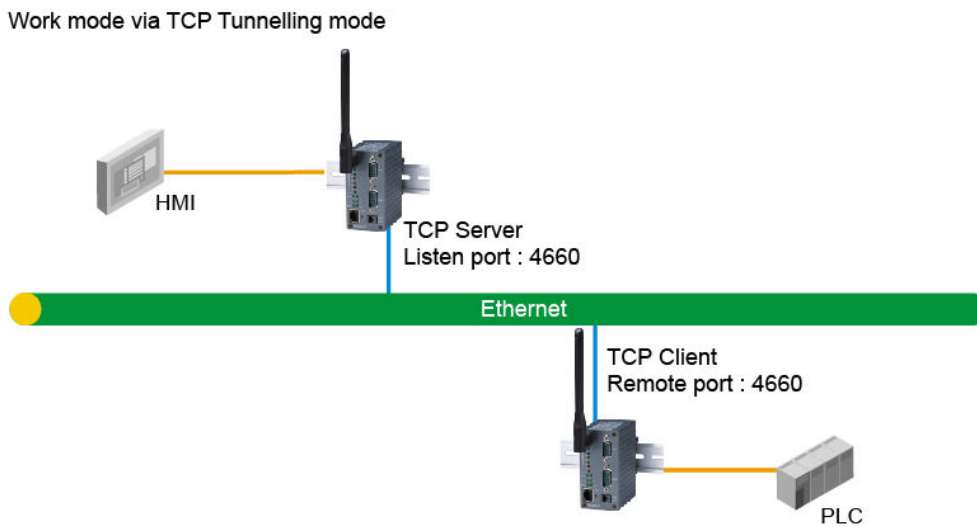
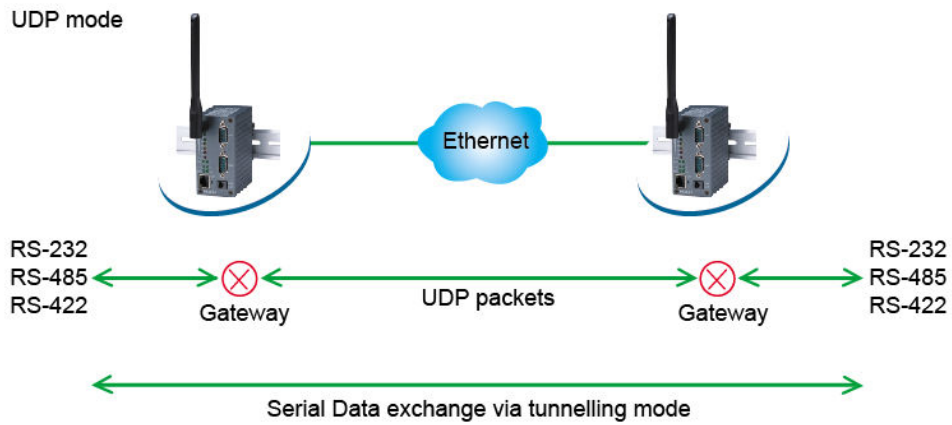

Fig. 9. TCP Tunneling Mode

### 4.6. UDP mode

In UDP mode, users may exchange Multicast data from one PC-W with multiple PC-W devices as shown in Fig. 10.



**Fig. 10. UDP Link in Tunneling mode**

### Configure PC-W in UDP Mode

Use one of the two configuration methods (Web-based or Windows-based **Serial Manager Utility**). Users can configure PC-W to UDP mode. In UDP mode, PC-W can be configured to communicate to more than one node (Multicasting). Note that the Multicast IP address is limited by the Class of IP address and subnet mask. As an example, for a network of Class C of subnet 192.168.1.X and a subnet mask of 255.255.255.0, the maximum Multicast IP address to be configured is four destinations IP's.

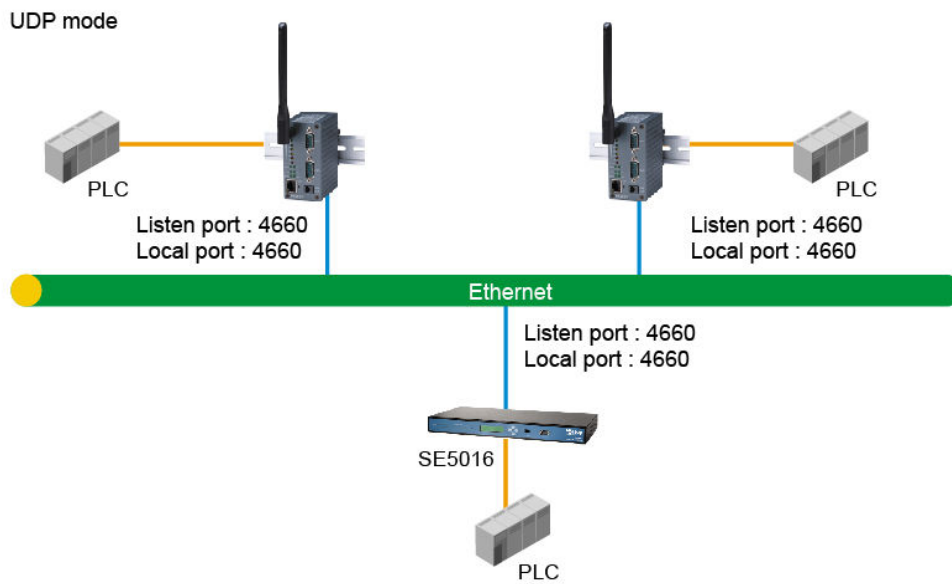

**Fig. 11. Multi-UDP Link in Tunneling Mode**

## 5. Configure PC-W by Web Interface

Users need to assign an IP address to PC-W before working on the web configuration operations. Please refer to Section 3.2 for IP address assignment.

### 5.1. Login to System

Open one of the web browsers, ex. Microsoft IE or Firefox etc. Enter the IP address of PC-W on the URL. Example: `http://10.0.50.100` or `http://your-device-IP-address`.

The following authentication screen shall appear. Enter User Name and Password then click on “OK”. The default user name is “**admin**” and password is **null** (leave it blank).



**Fig. 12. Authentication request for system security**

### 5.2. General Information

Once the login is successful, an Overview window gives the general information of PC-W, included Network, and Serial information as shown in Fig. 13.



# Overview

## Device Information

Model Name	PC-W
Device Name	0060e9035a9e
Kernel Version	1.19
AP Version	1.36

## Wireless Client Adaptor Information

MAC Address	00:60:E9:03:5A:9E
Region	America
IP Address	192.168.1.61
Status	3Com 00:0E:6A:D6:9F:BE  100%

## COM 1 Information

Serial Interface	RS-232
Link Mode	TCP Server
Baud Rate	9600
Parity	None
Data bits	8
Stop bits	1
Flow Control	None
Link Status	SERVER MODE: Listening[0]

COM 2 Information	
Serial Interface	RS-232
Link Mode	TCP Server
Baud Rate	9600
Parity	None
Data bits	8
Stop bits	1
Flow Control	None
Link Status	SERVER MODE: Listening[0]

**Link Status: [N] is the session number connected. It's [0] when the link is connecting or listening.**

Fig. 13. Overview of system information on a Web Interface

### 5.2.1. Device Information

PC-W's system information includes Model Name, Device Name, Kernel Version, and AP version. The information is read only and is attributed from setting page or system status.

Device Information	
Model Name	PC-W
Device Name	0060e9035a9e
Kernel Version	1.19
AP Version	1.36

Fig. 14. Device Information from Overview web page

### 5.2.2. Wireless Client Adaptor Information

Wireless Client Adaptor Information fields display both LAN & Wireless LAN (WLAN) information. The information provided are LAN MAC address, Region for Regulation, LAN IP address, WLAN MAC address, [WLAN IP address](#), and Link status.

Wireless Client Adaptor Information	
MAC Address	00:1A:4D:3C:6F:AF
Region	America
IP Address	192.168.0.132
Status	3Com 00:0E:6A:D6:9F:BE  100%

**Fig. 15. Wireless Client Adaptor Information from Overview web page**

### 5.2.3. Serial Information

PC-W COM1 (COM2) information includes UART mode, link mode, baud rate, parity, data bits, stop bits, flow control and link status. The COM1 (COM2) information is read only and is attributed from Serial settings of COM1 or COM2 Port of PC-W.

<b>COM 1 Information</b>	
Serial Interface	RS-232
Link Mode	TCP Server
Baud Rate	9600
Parity	None
Data bits	8
Stop bits	1
Flow Control	None
Link Status	SERVER MODE: Listening[0]

**Fig. 16. Serial Information from Overview web page**

### 5.3. Network Configurations

There are three items allowed to change on Networking page, included Wireless Client Adaptor Settings, DNS Setting and SNMP Settings.

# Networking

## TCP/IP

After saving the configuration, you need to reboot the adaptor to make the settings effective.

### Wireless Client Adaptor Settings

DHCP	<input type="checkbox"/> Obtain IP automatically
IP Address	10 . 0 . 50 . 100
Subnet Mask	255 . 255 . 0 . 0
Default Gateway	10 . 0 . 0 . 254

## DNS

### DNS Settings

DNS1	168 . 95 . 1 . 1
DNS2	0 . 0 . 0 . 0

## SNMP

By enabling SNMP you allow the management utility to collect the information of the Wireless Client Adaptor. You can re-define the device name, location and contact.

### SNMP Settings

SNMP	<input checked="" type="checkbox"/> Enable SNMP
SysName	0060E9-02F8B2
SysLocation	location
SysContact	contact
Read Community	public
Write Community	private
SNMP Trap Server	0 . 0 . 0 . 0
Alert Event	<input type="checkbox"/> Cold Start <input type="checkbox"/> Warm Start <input type="checkbox"/> Link Down <input type="checkbox"/> Link Up <input type="checkbox"/> Authentication Failure

Save

Fig. 17. Network information by Web page

### 5.3.1. Wireless Client Adaptor Settings

Click on the "Network" link and the following screen shall appear. Fill in network information on WLAN interface including IP Address, Subnet Mask, and Default Gateway. Alternatively, User may activate DHCP client function by checking on "Obtain an IP automatically" field to automatically obtain IP Address, Subnet mask and Default gateway from a DHCP server.

Wireless Client Adaptor Settings	
DHCP	<input type="checkbox"/> Obtain IP automatically
IP Address	10 . 0 . 50 . 100
Subnet Mask	255 . 255 . 0 . 0
Default Gateway	10 . 0 . 0 . 254

**Fig. 18. Wireless Client Adaptor Settings from Network web page**

### 5.3.2. DNS Settings

Click on the “Network” link and the following screen shall appear. Fill in the IP Address of DNS Servers in DNS1 and DNS2 fields. Alternatively, User can configure DNS by checking on “Obtain an IP automatically” field in LAN Settings or WLAN Settings fields to automatically obtain DNS from a DHCP server.

DNS Settings	
DNS1	168 . 95 . 1 . 1
DNS2	0 . 0 . 0 . 0

**Fig. 19. DNS Settings from Network web page**

### 5.3.3. SNMP Settings

Click on the “Network” link and the following screen shall appear. Check on “Enable SNMP” checkbox to continue the setting. Fill in the desired SysName, SysLocation, SysContact information in the fields. To give permission to read/write SNMP information, fill in the “Read Community” and “Write Community”. To set up a trap, fill in the IP address of a SNMP Trap Server, and then select events on which the trap server will catch. The changes of SNMP Settings will take effect only after the PC-W is restarted.

SNMP Settings	
SNMP	<input checked="" type="checkbox"/> Enable SNMP
SysName	<input type="text" value="0060E9-02F8B2"/>
SysLocation	<input type="text" value="location"/>
SysContact	<input type="text" value="contact"/>
Read Community	<input type="text" value="public"/>
Write Community	<input type="text" value="private"/>
SNMP Trap Server	<input type="text" value="0"/> . <input type="text" value="0"/> . <input type="text" value="0"/> . <input type="text" value="0"/>
Alert Event	<input type="checkbox"/> Cold Start <input type="checkbox"/> Warm Start <input type="checkbox"/> Link Down <input type="checkbox"/> Link Up <input type="checkbox"/> Authentication Failure

Fig. 20. SNMP Setting from Network web page

### 5.4. Wireless Configuration

There are three configuration pages for Wireless Configuration which are Default, Current and Site-Survey Information Pages. Click on “Wireless” link and the following screen shall appear.

## Wireless

There are three buttons in this page.  
 "Rescan": Search wireless AP.  
 "Select" : Start to connect or Change to default.  
 "User Define": Set wireless manually.

Default Information						
SSID	BSSID (AP MAC)	Topology	TxRate	Channel	Encryption	IP Adress
(Any)	(Any)	Infrastructure	54.0 Mb/s	Auto	None	192.168.1.1

Current Information						
SSID	BSSID (AP MAC)	Topology	TxRate	Channel	Encryption	Status
wlandemo	00:13:46:FE:B0:2E	Infrastructure	54.0 Mb/s	6	NONE	<div style="width: 100%; height: 10px; background-color: #00FF00; border: 1px solid #00FF00;"></div> 100%

Region: [ Americas ] Wireless Band Mode: [ BG Mixed ]						
Select	SSID	BSSID (AP MAC)	Topology	Channel	Encryption	Strength%
<input checked="" type="radio"/>	(Any)	(Any)	Infrastructure	1	None	None

Fig. 21. Wireless Interface Information by Web page

There are 3 buttons can be operated on the Wireless page

- **Rescan:** Click on the “Rescan” button, and PC-W will start site-survey procedures, then on the site-survey list will display the access points founded.
- **Select:** On the site-survey list, click on radio button to attach to the access point you wanted.
- **User defined:** Users can also define information of wireless access point to be manually connected.

#### 5.4.1. Wireless Settings

Users can configure wireless LAN parameters through web pages. Pop-up windows page will be shown for advanced wireless settings if “Select” or “User Define” button was clicked. For example, User can configure SSID, BSSID, Topology, Wireless Band Mode, TxRate, Channel, Authentication, and Encryption of the access point that PC-W want to connect to.

The advanced wireless settings also include Roaming Threshold. User can configure roaming signal threshold. PC-W will change to the stronger signal wireless access point, if the original access point’s signal strength is less than the roaming threshold.

Fig. 22. Pop-up Windows for Wireless Settings

#### 5.4.2. Sample Wireless Application Cases

Below are some screen shot examples of Wireless Settings for different wireless security schemes.

##### I. Attach to the access point without authentication

- **Topology:** Infrastructure Mode
- **Channel:** Auto-assignment from Access point
- **Authentication:** Open
- **Encryption:** None



Wireless Setting	
Roaming Threshold (%/dBm)	<input type="radio"/> Low (25%/ -80) <input checked="" type="radio"/> Normal (50%/ -70) <input type="radio"/> High (75%/ -60)
SSID	<input type="text"/> <small>Leaving it blank may connect to unexpected Access Point.</small>
BSSID (AP MAC)	<input type="text"/> <input type="checkbox"/> Enable
Topology	Infrastructure Mode
Wireless Band Mode	BG Mixed
TxRate	Auto
Channel	1
Authentication	Open
Encryption	None
WPA-PSK ( 8 ~ 63 characters )	<input type="text"/>
<input checked="" type="radio"/> WEP Key1	Hexadecimal <input type="text"/> 64bits <input type="text"/>
<input type="radio"/> WEP Key2	Hexadecimal <input type="text"/> 64bits <input type="text"/>
<input type="radio"/> WEP Key3	Hexadecimal <input type="text"/> 64bits <input type="text"/>
<input type="radio"/> WEP Key4	Hexadecimal <input type="text"/> 64bits <input type="text"/>

Fig. 23. Open Authorization and no Encryption

## II. Attach to the access point with WEP Encryption

- **Topology:** Infrastructure
- **Channel:** Auto-assignment from Access point
- **Authentication:** Shared
- **Encryption:** WEP
- **WEP Key1~4:** Hexadecimal or ASCII, 64 or 128bit, <WEP Key>

Wireless Setting	
Roaming Threshold (%/dBm)	<input type="radio"/> Low (25%/ -80) <input checked="" type="radio"/> Normal (50%/ -70) <input type="radio"/> High (75%/ -60)
SSID	<input type="text"/> <small>Leaving it blank may connect to unexpected Access Point.</small>
BSSID (AP MAC)	<input type="text"/> <input type="checkbox"/> Enable
Topology	Infrastructure Mode
Wireless Band Mode	BG Mixed
TxRate	Auto
Channel	1
Authentication	Shared
Encryption	WEP
WPA-PSK ( 8 ~ 63 characters )	<input type="text"/>
<input checked="" type="radio"/> WEP Key1	Hexadecimal <input type="text"/> 64bits <input type="text"/>
<input type="radio"/> WEP Key2	Hexadecimal <input type="text"/> 64bits <input type="text"/>
<input type="radio"/> WEP Key3	Hexadecimal <input type="text"/> 64bits <input type="text"/>
<input type="radio"/> WEP Key4	Hexadecimal <input type="text"/> 64bits <input type="text"/>

Fig. 24. Share Authorization and WEP Encryption

Note1: Enter 5 ASCII value or 10 Hexadecimal digit if select 64-bit encryption.  
 Note2: Enter 13 ASCII value or 26 Hexadecimal digit if select 128-bit encryption.

## III. Attach to the access point with WPA-PSK Encryption

- **Topology:** Infrastructure
- **Channel:** Auto-assignment from Access point



- **Authentication:** WPA-PSK
- **Encryption:** TKIP or AES
- **WPA-PSK:** 8~63 Characters

Wireless Setting	
Roaming Threshold (%/dBm)	<input type="radio"/> Low (25%/-80) <input checked="" type="radio"/> Normal (50%/-70) <input type="radio"/> High (75%/-60)
SSID	<input type="text"/> <small>Leaving it blank may connect to unexpected Access Point.</small>
BSSID (AP MAC)	<input type="text"/> <input type="checkbox"/> Enable
Topology	Infrastructure Mode ▾
Wireless Band Mode	BG Mixed ▾
TxRate	Auto ▾
Channel	1 ▾
Authentication	WPA-PSK ▾
Encryption	TKIP ▾
WPA-PSK ( 8 ~ 63 characters )	<input type="text"/>
<input checked="" type="radio"/> WEP Key1	Hexadecimal ▾ 64bits ▾ <input type="text"/>
<input type="radio"/> WEP Key2	Hexadecimal ▾ 64bits ▾ <input type="text"/>
<input type="radio"/> WEP Key3	Hexadecimal ▾ 64bits ▾ <input type="text"/>
<input type="radio"/> WEP Key4	Hexadecimal ▾ 64bits ▾ <input type="text"/>

**Fig. 25. WPA-PSK Authorization and TKIP Encryption**

## 5.5. COM Port Configuration

Users can configure Serial parameters including UART mode, baud rate, parity, data bit and type of flow control and the mode of operations, which are TCP Server, TCP Client, and UDP modes. The COM Port Configuration page is shown in Fig. 26.

### 5.5.1. TCP Server Mode

TCP Server mode is the default Link mode of Serial Settings as shown in Fig. 27. In this mode, the connection waits for a connecting requirement from a remote host PC which is running a “Serial to IP” utility or setting PC-W in tunneling mode. Users need to configure a listening port to allow clients establishing a connection to this server. Default port number of COM1 is 4660.

IP filtering function is a simple ACL (Access Control List) for incoming IP packets. It can be disabled by setting Source IP to “0.0.0.0”. Users can configure one or a group of IP address for Source IP. If IP filter is enabled, only source IP assigned can be connected to PC-W.

**Note: Enable Virtual COM mode if the remote site PC’s “Serial to IP” tool is installed**

### 5.5.2. TCP Client Mode

Users may enter a Destination IP and Destination port (default: 4660) to establish a connection of counter-pair (remote) host (for example, another PC-W or PC for data collection) as shown in Fig. 28. PC-W can support up to two destination hosts simultaneously.

# COM 1

LINK Mode  
To choose specific working mode for COM 1 port.

TCP Server   
 TCP Client   
 UDP

UDP

Local Port:

Destination IP Address 1	<input checked="" type="checkbox"/> Enable	<input type="text" value="0"/> . <input type="text" value="0"/> . <input type="text" value="0"/> . <input type="text" value="0"/> ~ <input type="text" value="0"/>	Port <input type="text" value="4660"/>
Destination IP Address 2	<input type="checkbox"/> Enable	<input type="text" value="0"/> . <input type="text" value="0"/> . <input type="text" value="0"/> . <input type="text" value="0"/> ~ <input type="text" value="0"/>	Port <input type="text" value="4660"/>
Destination IP Address 3	<input type="checkbox"/> Enable	<input type="text" value="0"/> . <input type="text" value="0"/> . <input type="text" value="0"/> . <input type="text" value="0"/> ~ <input type="text" value="0"/>	Port <input type="text" value="4660"/>
Destination IP Address 4	<input type="checkbox"/> Enable	<input type="text" value="0"/> . <input type="text" value="0"/> . <input type="text" value="0"/> . <input type="text" value="0"/> ~ <input type="text" value="0"/>	Port <input type="text" value="4660"/>

To configure COM 1 port parameters.

Serial Settings

Serial Interface	<input checked="" type="radio"/> RS232 <input type="radio"/> RS422 <input type="radio"/> RS485
Baud Rate	<input type="text" value="9600"/> bps
Parity	<input checked="" type="radio"/> None <input type="radio"/> Odd <input type="radio"/> Even <input type="radio"/> Mark <input type="radio"/> Space
Data bits	<input type="radio"/> 5 bits <input type="radio"/> 6 bits <input type="radio"/> 7 bits <input checked="" type="radio"/> 8 bits
Stop bits	<input checked="" type="radio"/> 1 bit <input type="radio"/> 2 bits
Flow Control	<input checked="" type="radio"/> None <input type="radio"/> Xon/Xoff <input type="radio"/> RTS/CTS
Packet Delimiter (Network to Serial)	<input type="checkbox"/> Enable <input type="radio"/> Timer <input type="text" value="10"/> (10~30000) ms <input type="radio"/> Characters <input type="text" value="0x0d0a"/> ("0x"+ASCII Code, Ex. 0x0d or 0x0d0a)
Packet Delimiter (Serial to Network)	<input type="checkbox"/> Enable <input type="radio"/> Timer <input type="text" value="10"/> (10~30000) ms <input type="radio"/> Characters <input type="text" value="0x0d0a"/> ("0x"+ASCII Code, Ex. 0x0d or 0x0d0a)

Packet Delimiter: Collect data into single packet for reduce overhead.

Fig. 26. COM port Information Web Page

# COM 1

LINK Mode  
To choose specific working mode for COM 1 port.

TCP Server   
 TCP Client   
 UDP

TCP Server

Virtual COM	<input type="checkbox"/> Enable
IP Filter	<input type="checkbox"/> Enable
Source IP	<input type="text" value="0"/> . <input type="text" value="0"/> . <input type="text" value="0"/> . <input type="text" value="0"/>
Local Port	<input type="text" value="4660"/>
Connect Number Limit	<input type="text" value="1"/>

Fig. 27. TCP Server in Link mode

**COM 1**

LINK Mode  
To choose specific working mode for COM 1 port.

TCP Server   
 TCP Client   
 UDP

TCP Client	
Destination IP 1	0 . 0 . 0 . 0
Destination Port 1	4660
Destination 2	<input type="checkbox"/> Enable
Destination IP 2	0 . 0 . 0 . 0
Destination Port 2	4660

**Fig. 28. TCP Client in Link mode**

### 5.5.3. UDP Mode

PC-W can be configured in a UDP mode to establish connection using Unicast or Multicast data from the serial device to one or multiple host computers as shown in Fig. 29. Vice versa is also true. For example, the original RS-422/ RS485 bus can be transferred and extended connection distance by PC-W.

The destination IP is assigned by a single IP or a group of IP addresses. The configuration is limited by the Local Listening Port. For example, the PC-W listening port is 4660 which receives data sending from the host computers. PC-W can support up to 4 group IP addresses for UDP connection, if users needed.

**Note: In UDP mode, the device does not support Virtual COM mode.**

**COM 1**

LINK Mode  
To choose specific working mode for COM 1 port.

TCP Server   
 TCP Client   
 UDP

UDP	
Local Port	4660
Destination IP Address 1	<input checked="" type="checkbox"/> Enable    0 . 0 . 0 . 0 ~ 0    Port 4660
Destination IP Address 2	<input type="checkbox"/> Enable    0 . 0 . 0 . 0 ~ 0    Port 4660
Destination IP Address 3	<input type="checkbox"/> Enable    0 . 0 . 0 . 0 ~ 0    Port 4660
Destination IP Address 4	<input type="checkbox"/> Enable    0 . 0 . 0 . 0 ~ 0    Port 4660

**Fig. 29. UDP protocol in Link mode**

### 5.5.4. Serial Settings

The Serial settings of parameters for PC-W are shown in Fig. 30. Users can configure Serial parameters including UART Mode, baud rate, parity, data bit and type of flow control.

- **Configure UART Mode:** RS-232 or RS-485 or RS-422
- **Baud rate (bps):** 1200, 2400, 4800, 9600, 19200, 38400, 57600, 115200, 230400
- **Parity:** None or Odd or Even or Mark or Space
- **Data bits:** 7 or 8
- **Stop bits:** 1 or 2

- **Flow control:** None or Xon/Xoff or Hardware (RTS/CTS).

Serial Settings	
Serial Interface	<input checked="" type="radio"/> RS232 <input type="radio"/> RS422 <input type="radio"/> RS485
Baud Rate	115200 bps
Parity	<input checked="" type="radio"/> None <input type="radio"/> Odd <input type="radio"/> Even <input type="radio"/> Mark <input type="radio"/> Space
Data bits	<input type="radio"/> 5 bits <input type="radio"/> 6 bits <input type="radio"/> 7 bits <input checked="" type="radio"/> 8 bits
Stop bits	<input checked="" type="radio"/> 1 bit <input type="radio"/> 2 bits
Flow Control	<input checked="" type="radio"/> None <input type="radio"/> Xon/Xoff <input type="radio"/> RTS/CTS
Packet Delimiter (Network to Serial)	<input type="checkbox"/> Enable <input type="radio"/> Timer <input type="text" value="10"/> (10~30000) ms <input type="radio"/> Characters <input type="text" value="0x0d0a"/> ("0x"+ASCII Code, Ex. 0x0d or 0x0d0a)
Packet Delimiter (Serial to Network)	<input type="checkbox"/> Enable <input type="radio"/> Timer <input type="text" value="10"/> (10~30000) ms <input type="radio"/> Characters <input type="text" value="0x0d0a"/> ("0x"+ASCII Code, Ex. 0x0d or 0x0d0a)

**Fig. 30. Serial Communication Settings from Web Page**

### 5.5.5. Packet delimiter

Packet delimiter is a way of controlling the number of packets in a serial communication. It is designed to keep packets in track. PC-W provides two ways in parameter setting: (1) Packet delimiter by timer and (2) packet delimiter by Character pattern. By default, packet delimiter timer is 10 ms. the range of packet delimiter timer is 10 to 30,000 ms. For Character pattern terminator, if a character pattern is selected and a data stream ended with "0x0a04", then the entire data buffer of the serial device is transmitted.

## 5.6. Configure System

There are five items for system settings, including Time, WLAN Region, Security, Set to default and Restart.



**Fig. 31. Subsystem menu of system settings by Web Interface**

### 5.6.1. Configure Time by NTP Service

User can set date and time manually by enable "Manual Settings" and fill in date and time manually. User can also enable "NTP" to obtain time automatically from a Time Zone and a NTP server.

## Time

By enabling NTP you allow to adjust and set the device internal time, relative to Greenwich Mean Time.

**Current System Time**

Sun Jan 1 15:31:25 UTC 2006

---

**Enable NTP**

**Local Time Zone Setting**

Time Zone: (GMT) Greenwich Mean Time: Dublin, Edinburgh, Lisbon, London

**Sync with Time Server (NTP)**

NTP Server: time.nist.gov

---

**Enable Manual Setting**

**Date and Time Settings**

Date: Year: 2006 / Month: Jan / Day: 1

Time: Hour:(0~23): 15 Minute:(0~59): 31 Second:(0~59): 25

**Fig. 32. Time service settings from System web page**

### 5.6.2. WLAN Region

Click on the “WLAN Region” link and the following screen shall appear. Select the country from drop-down list box to the country that user wants to deploy the PC-W. This selection will affect the bands of channels of PC-W wireless mode. For example, the normal system level channel configurations for deployments are channels 1, 6 and 11 for FCC countries and 1, 5, 9 and 13 for European Union countries.

## WLAN Region

The default Country is Americas, you can change the Country by selecting. This item influenced the bands of channel and Wireless Mode.

Country Region	America
B/G Band Region	1,2,3,4,5,6,7,8,9,10,11

**Fig. 33. Time service settings from System web page**

### 5.6.3. Security (Password Change)

Click on the “Security” link and the following screen shall appear. Enter the old password on “Old Password” field then enter the new password on “New Password” and the “Verified Password” fields, and then click on “Save Configuration” to update the password. The maximum number of characters of each field is 8 characters.

**Note:** User may press the default reset key to reset password to the default value (blank)

## Security

The default password is null, you can change the password by filling in the new password to New Password and Verified Password fields, be aware that password is case sensitive.

Old Password	<input type="text"/>
New Password	<input type="text"/>
Verified Password	<input type="text"/>

**Fig. 34. Change password from System Security Page**

#### 5.6.4. Restoring Factory Default Configurations

User can click on “Set to default and Restart” button to restore PC-W’s settings to factory default.

## Set to default

Restore all parameters to default.

**Fig. 35. Set all parameters to factory default by Web Interface**

#### 5.6.5. Restart System

The changes of networking parameters will take effect only after the PC-W is restarted. User can restart the PC-W manually by click on Restart button on the restart menu web page.

## Restart

When the system stops responding correctly, you can perform this. The restart will be complete when the RUN LED starts blinking.

**Fig. 36. Restart system by Web**



## 5.7. Applications

### 5.7.1. Paperless Recorder VR18 (Ethernet port) to Wireless Ethernet

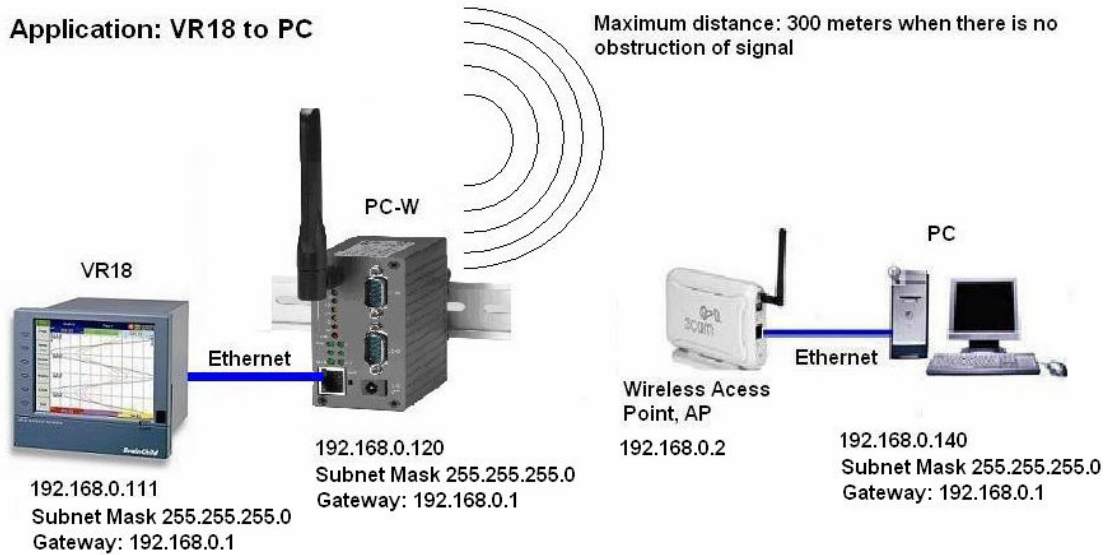

**Fig. 37. Application between PC-W and VR18**

Procedure as follows..

1. Install Serial Manager in PC
2. PC-W default IP address: 10.0.50.100
3. Set IP address of PC as 10.0.50.110, Subnet Mask 255.255.255.0 & Default Gateway: 10.0.50.1. Since IP address of PC is in same domain as PC-W, now, it is possible to configure PC-W from PC
4. Switch on Power supply to PC-W. Connect PC-W to PC via Cross over Ethernet Cable or LAN cable
5. Open Serial Manager. If step3 and step4 is proper, then PC-W will be detected by Serial manager and it is shown as follows

SerialManager V4.01.08							
Search Firmware Configuration Security View Advance Virtual COM About							
No.	Caution	Model	IP Address	MAC Address	Host Name	Kernel	AP Information
1		PC-W	10.0.50.100	00:1A:4D:3C:6F:AF	0060E9-02F85E	V1.17	PC-W V1.31

6. Now select PC-W and then click on browser "e" as follows



Select PC-W then click at browser "e"

7. Log in screen appear as follows

User name = admin

Password = just leave it blank

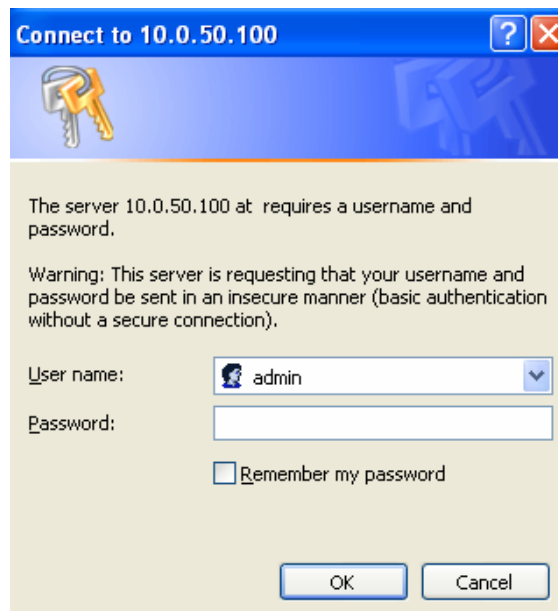

8. Click on "OK", then Wireless Client Adopter overview screen appear as follows.



http://10.0.50.100/index.asp - Windows Internet Explorer

http://10.0.50.100/index.asp

**Wireless Client Adaptor**

- Overview
- Network
- Wireless
- Serial
- System

## Overview

Device Information	
Model Name	PC-W
Device Name	BrainChild
Kernel Version	1.17
AP Version	1.31

Wireless Client Adaptor Information	
MAC Address	00:1A:4D:3C:6F:AF
Region	America
IP Address	10.0.50.100

9. Now, click on Network on left hand side of the Menu. It shows Networking screen as follows. It is possible to modify IP address of PC-W at this location. We suggest not to select option at "Obtain IP address automatically"

ATOP PC-W - Windows Internet Explorer

http://10.0.50.100/network.asp

ATOP PC-W

**Wireless Client Adaptor**

- Overview
- Network
- Wireless
- Serial
- System

## Networking

TCP/IP  
To configure network settings of Serial Server. After saving configuration you have to restart the device to make the settings effective.

LAN Settings	
DHCP	<input type="checkbox"/> Obtain IP automatically
IP Address	10 . 0 . 50 . 100
Subnet Mask	255 . 255 . 0 . 0
Default Gateway	10 . 0 . 0 . 254

10. Paperless Recorder VR18/VR06 has Ethernet port by Default. Assume Recorder IP address is 192.168.0.111
11. Now, it requires to Set IP address of PC-W to the above domain. So, click on Networking and then do LAN settings properly as follows..., scroll down to bottom and then click on "Save" button. Click on "Restart" when prompted in the screen and PC-W will restart in 60 sec

LAN Settings	
DHCP	<input type="checkbox"/> Obtain IP automatically
IP Address	192 . 168 . 0 . 120
Subnet Mask	255 . 255 . 255 . 0
Default Gateway	192 . 168 . 0 . 1

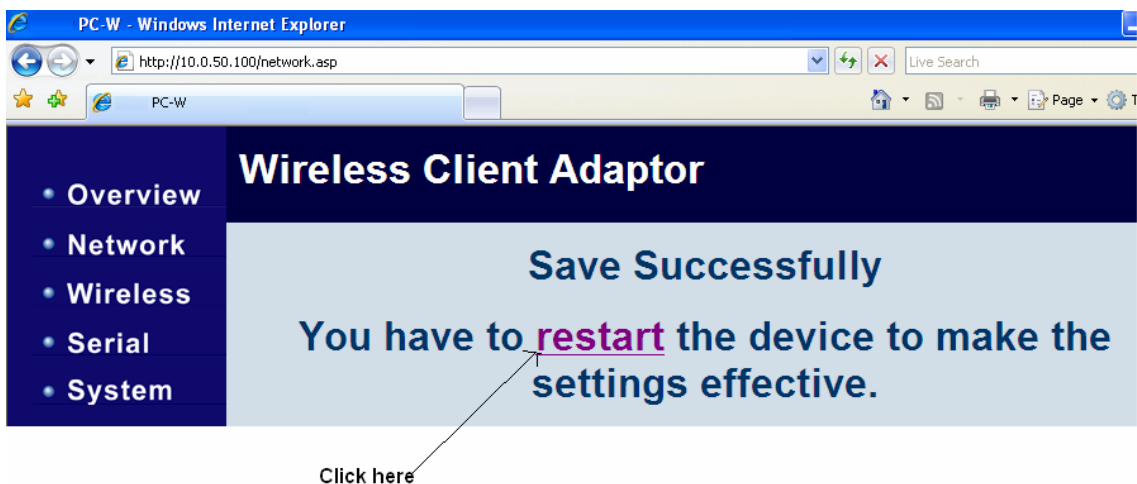

12. Now, change IP address, subnet mask and gateway address in PC in same domain of VR18 and Wireless AP or just set "obtain an IP address automatically" as shown below

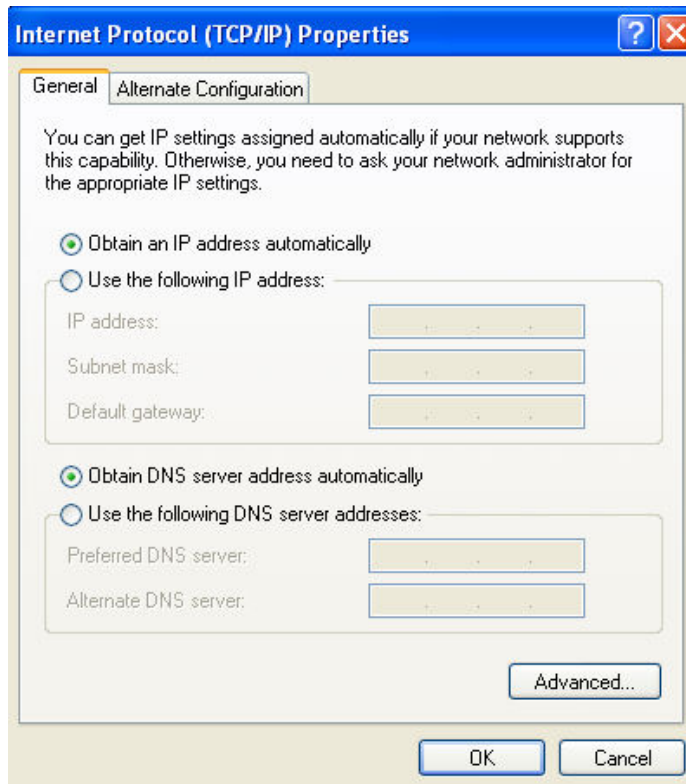

13. Now, close the serial manager and open again. Then, it should detect PC-W and shows as follows

No.	Caution	Model	IP Address	MAC Address	Host Name	Kernel	AP Information
1		PC-W	192.168.0.120	00:1A:4D:3C:6F:AF	0060E9-02F85E	V1.17	PC-W V1.31

14. If there is good communication between PC-W and Your wireless AP, then green color LED should be flashing slowly at PC-E. If not, then from the serial Manager, it requires to connect your Wireless AP provider properly

Click on Wireless, then click on "Rescan" button, it scans all the available wireless access points. Select the required access point and then "Save settings and Connect". Then your wireless access point should be selected in Current information and it also shows status

• Overview  
• Network  
• Wireless  
• Serial  
• System

## Wireless Client Adaptor

### Wireless

There are three buttons in this page.  
 "Rescan": Search wireless AP.  
 "Select" : Start to connect or Change to default.  
 "User Define": Set wireless manually.

Default Information						
SSID	BSSID (AP MAC)	Topology	TxRate	Channel	Encryption	IP Address
(Any)	(Any)	Infrastructure	54.0 Mb/s	Auto	None	192.168.0.120

Current Information						
SSID	BSSID (AP MAC)	Topology	TxRate	Channel	Encryption	Status
3Com	00:0E:6A:D6:9F:BE	Infrastructure	54.0 Mb/s	11	NONE	100%

Rescan

Region: [ Americas ]  
 Wireless Band Mode: [ BG Mixed ]

Select	SSID	BSSID (AP MAC)	Topology	Channel	Encryption	Strength%
<input type="radio"/>	(Any)	(Any)	Infrastructure	1	None	None

Select User Define

- Now, close serial Manager and disconnect Ethernet cable between PC-W and PC.
- Now connect VR18 with PC-W via cross over Ethernet cable or Straight through cable. At this time, VR18 is virtually connected to your wireless access point. If connection is successful, then you can see Green color LED flashing at Ethernet port at PC-W. In Recorder, Green LED will be on continuously and orange LED will be flashing at Ethernet port. You may check VR18 using "Ping" instruction at dos prompt from any PC connected to LAN or Wireless AP. If there is no reply, then it requires to check Ethernet cable, IP address of Recorder, setting of IP address at PC-W and also wireless AP settings

```

C:\ Command Prompt
Microsoft Windows XP [Version 5.1.2600]
(C) Copyright 1985-2001 Microsoft Corp.

C:\Documents and Settings\user>ping 192.168.0.111

Pinging 192.168.0.111 with 32 bytes of data:

Reply from 192.168.0.111: bytes=32 time=6ms TTL=128
Reply from 192.168.0.111: bytes=32 time=2ms TTL=128
Reply from 192.168.0.111: bytes=32 time=2ms TTL=128
Reply from 192.168.0.111: bytes=32 time=8ms TTL=128

Ping statistics for 192.168.0.111:
    Packets: Sent = 4, Received = 4, Lost = 0 (0% loss),
    Approximate round trip times in milli-seconds:
        Minimum = 2ms, Maximum = 8ms, Average = 4ms

C:\Documents and Settings\user>
  
```

- Now, in Observer software, create a new project and enter IP address of Recorder. Please note that there is no need to enter IP address of PC-W or Wireless AP device in Observer software.

### 5.7.2. Paperless Recorder VR18 (Serial port) to Wireless Ethernet

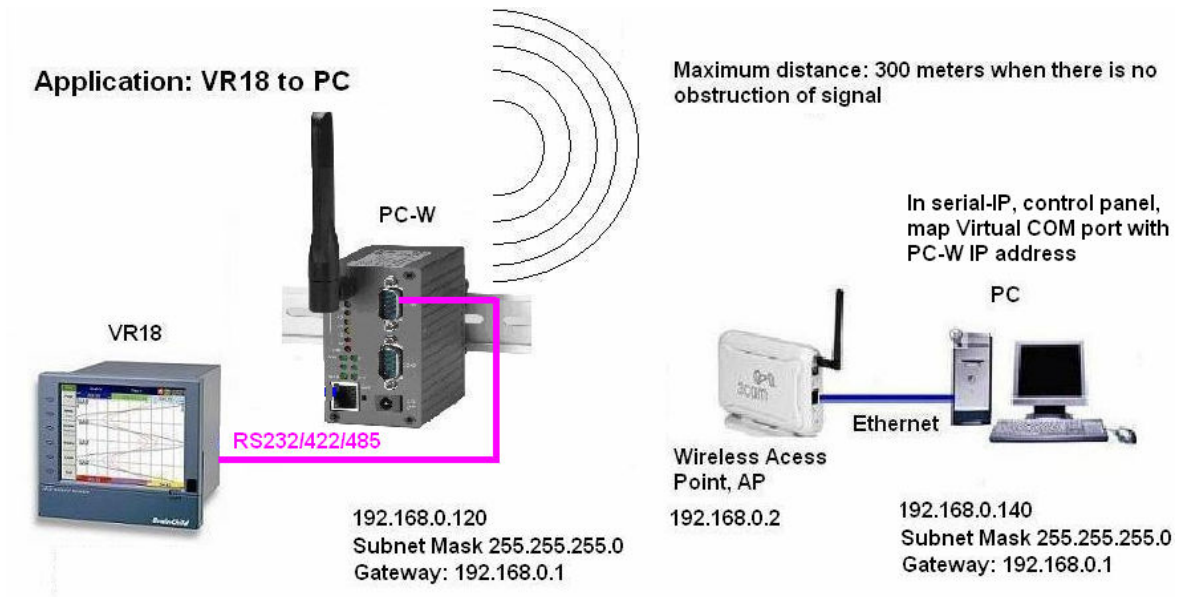

Procedure as follows..

1. Install Serial Manager in PC
2. PC-W default IP address: 10.0.50.100
3. Set IP address of PC as 10.0.50.110, Subnet Mask 255.255.255.0 & Default Gateway: 10.0.50.1. Since IP address of PC is in same domain as PC-W, now, it is possible to configure PC-W from PC
4. Switch on Power supply to PC-W. Connect PC-W to PC via Cross over Ethernet Cable or LAN cable
5. Open Serial Manager. If step3 and step4 is proper, then PC-W will be detected by Serial manager and it is shown as follows

SerialManager V4.01.08							
No.	Caution	Model	IP Address	MAC Address	Host Name	Kernel	AP Information
1		PC-W	10.0.50.100	00:1A:4D:3C:6F:AF	0060E9-02F85E	V1.17	PC-W V1.31

6. Now select PC-W and then click on browser "e" as follows

SerialManager V4.01.08							
No.	Caution	Model	IP Address	MAC Address	Host Name	Kernel	AP Information
1		PC-W	10.0.50.100	00:1A:4D:3C:6F:AF	0060E9-02F85E	V1.17	PC-W V1.31

Select PC-W then click at browser "e"

7. Log in screen appear as follows

User name = admin

Password = just leave it blank

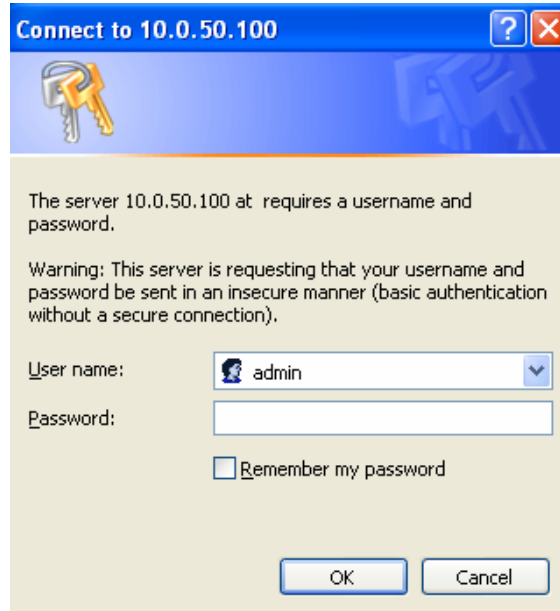

8. Click on "OK", then Wireless Client Adaptor overview screen appear as follows.





- Now, click on Network on left hand side of the Menu. It shows Networking screen as follows. It is possible to modify IP address of PC-W at this location. We suggest not to select option at "Obtain IP address automatically"



- Check IP address details of Server or wireless AP
- Now, it requires to Set IP address of PC-W to the above domain. So, click on Networking and then do LAN settings properly as follows..., scroll down to bottom and then click on "Save" button. Click on "Restart" when prompted in the screen and PC-W will restart in 60 sec

LAN Settings	
DHCP	<input type="checkbox"/> Obtain IP automatically
IP Address	192 . 168 . 0 . 120
Subnet Mask	255 . 255 . 255 . 0
Default Gateway	192 . 168 . 0 . 1

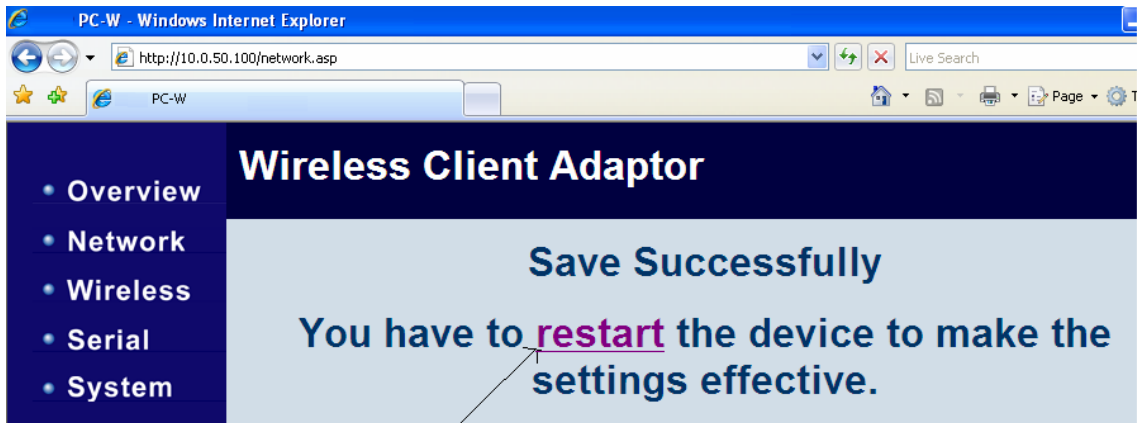

Click here

- Now, change IP address, subnet mask and gateway address in PC in same domain of Wireless AP or just set "obtain an IP address automatically" as shown below

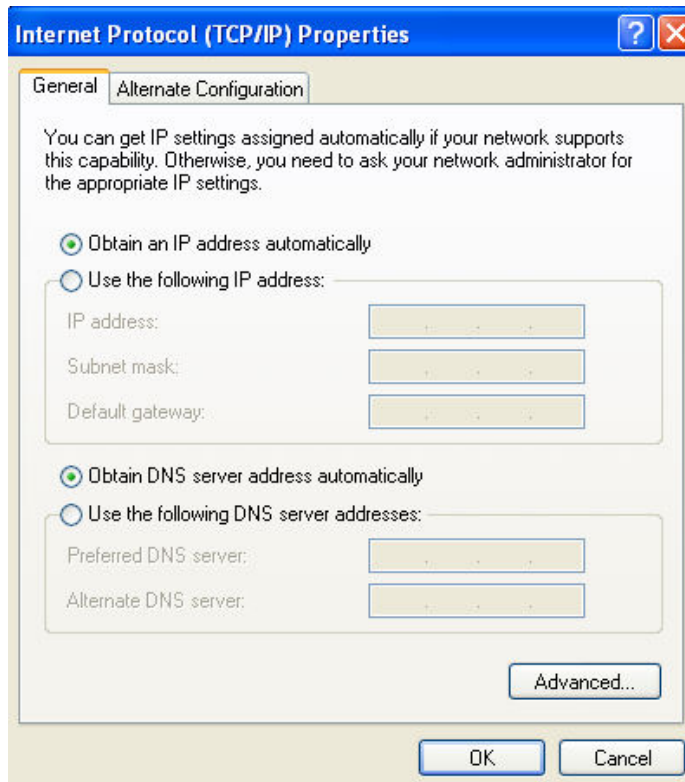

- Now, close the serial manager and open again. Then, it should detect PC-W and shows as follows

SerialManager V4.01.08							
Search Firmware Configuration Security View Advance Virtual COM About							
No.	Caution	Model	IP Address	MAC Address	Host Name	Kernel	AP Information
1		PC-W	192.168.0.120	00:1A:4D:3C:6F:AF	0060E9-02F85E	V1.17	PC-W V1.31



- If there is good communication between PC-W and Your wireless AP, then green color LED should be flashing slowly at PC-E. If not, then from the serial Manager, it requires to connect your Wireless AP provider properly

Click on Wireless, then click on “Rescan” button, it scans all the available wireless access points. Select the required access point and then “Save settings and Connect”. Then your wireless access point should be selected in Current information and it also shows status

The screenshot shows the 'Wireless Client Adaptor' web interface. On the left is a navigation menu with 'Wireless' selected. The main content area is titled 'Wireless' and contains instructions: 'There are three buttons in this page. "Rescan": Search wireless AP. "Select" : Start to connect or Change to default. "User Define": Set wireless manually.'

**Default Information**

SSID	BSSID (AP MAC)	Topology	TxRate	Channel	Encryption	IP Address
(Any)	(Any)	Infrastructure	54.0 Mb/s	Auto	None	192.168.0.120

**Current Information**

SSID	BSSID (AP MAC)	Topology	TxRate	Channel	Encryption	Status
3Com	00:0E:6A:D6:9F:BE	Infrastructure	54.0 Mb/s	11	NONE	100%

Buttons: Rescan

Region: [ Americas ]  
Wireless Band Mode: [ BG Mixed ]

Select	SSID	BSSID (AP MAC)	Topology	Channel	Encryption	Strength%
<input checked="" type="radio"/>	(Any)	(Any)	Infrastructure	1	None	None

Buttons: Select, User Define

- Now, close serial Manager and disconnect Ethernet cable between PC-W and PC.
- Now connect VR18 with PC-W COM1 port via serial cable say RS232. At this time, VR18 is virtually connected to your wireless access point.
- In VR18, press “Config”, then select “Instrument” and press Enter. Set communication parameters. Ex: PC Transfer = RS232/RS485/RS422, Address = 1, Baud rate = 38400, data format = No, 8, 1
- In serial manager, click on “Serial” and it shows the following screen. For COM1, select option “TCP Server” and enable Virtual COM enable as shown



Select PC-W COM1 settings same as VR18 COM port settings

To configure COM 1 port parameters.

Serial Settings	
Serial Interface	<input checked="" type="radio"/> RS232 <input type="radio"/> RS422 <input type="radio"/> RS485
Baud Rate	38400 bps
Parity	<input checked="" type="radio"/> None <input type="radio"/> Odd <input type="radio"/> Even <input type="radio"/> Mark <input type="radio"/> Space
Data bits	<input type="radio"/> 5 bits <input type="radio"/> 6 bits <input type="radio"/> 7 bits <input checked="" type="radio"/> 8 bits
Stop bits	<input checked="" type="radio"/> 1 bit <input type="radio"/> 2 bits
Flow Control	<input checked="" type="radio"/> None <input type="radio"/> Xon/Xoff <input type="radio"/> RTS/CTS
Packet Delimiter (Network to Serial)	<input type="checkbox"/> Enable
	<input type="radio"/> Timer <input type="text" value="10"/> (10~30000) ms <input type="radio"/> Characters <input type="text" value="0x0d0a"/> ("0x"+ASCII Code, Ex. 0x0d or 0x0d0a)
Packet Delimiter (Serial to Network)	<input type="checkbox"/> Enable
	<input type="radio"/> Timer <input type="text" value="10"/> (10~30000) ms <input type="radio"/> Characters <input type="text" value="0x0d0a"/> ("0x"+ASCII Code, Ex. 0x0d or 0x0d0a)

**Packet Delimiter: Collect data into single packet for reduce overhead.**

19. Click on "Save Configuration" button. Then it appears a message "Save successfully"
20. Now, it requires to create virtual COM port in PC for PC-W device. During installation of serial manager, Serial/IP redirector will be installed in PC. If not, install Serial/IP software from CD

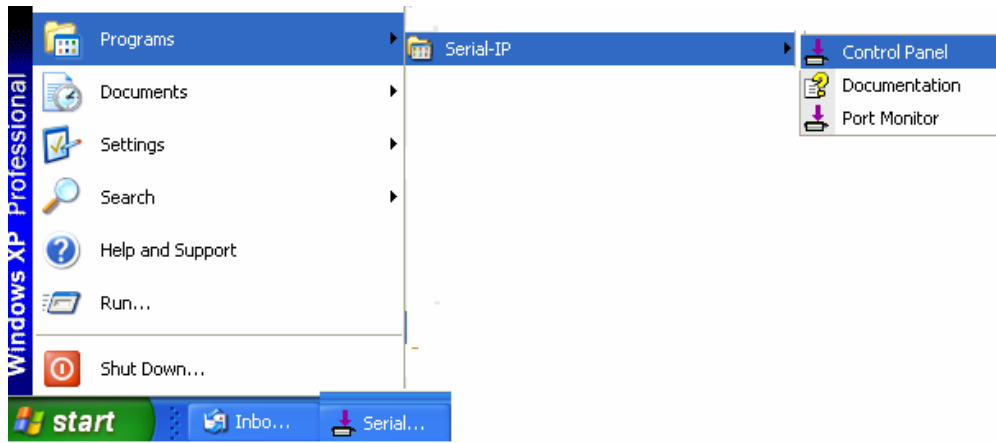

21. Open Serial-IP control panel and select the options as follows

Click at “Select ports” and then select Virtual port number required for VR18 paperless Recorder to use in Observer software

Select “Connect to Server”

Enter IP address of PC-W

Enter port number: 4660 (This is already configured at PC-W, COM1 settings)

Now Click on “Configuration wizard” to test connection between PC and VR18 via PC-W and Wireless Access Point

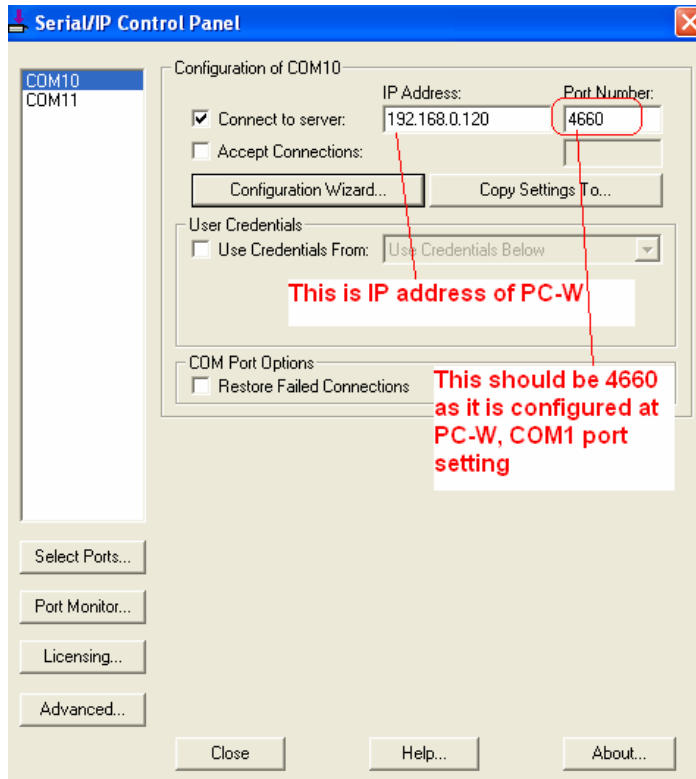

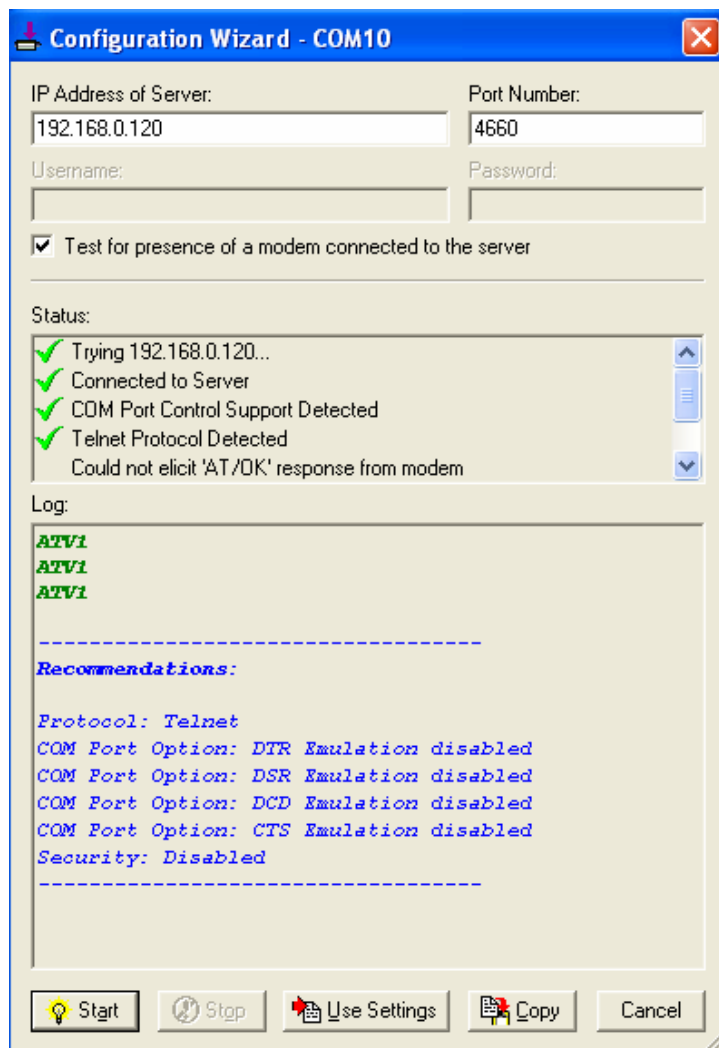

22. The above screen shows successful connection between PC and VR18 via PC-W and Wireless access point and now COM10 is virtual COM port in PC to be used in Observer software
23. Now open Observer software, Real time viewer and create new project. Set bank as shown below

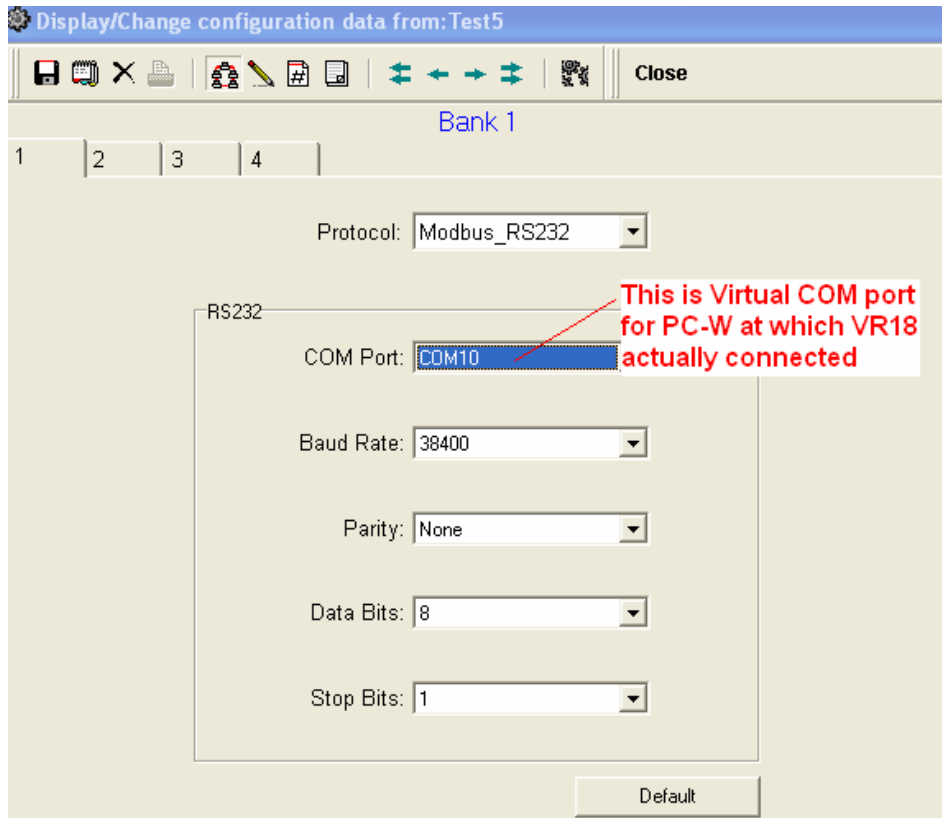

Display/Change configuration data from: C:\Observer II\Realtime\Test5.prj

Close

Add Modify Delete

Tag Name	Bank	Node/IP	Tag Type	Device Type	Addr...	EngHi	EngLo	Unit	Deci...	Alarm1	SP1
AI1	1	1	VR18	Channel1		4553.6	-199...	°C	1	Hi	776
AI2	1	1	VR18	Channel2		4553.6	-199...	°C	1	Hi	1059
AI3	1	1	VR18	Channel3		4553.6	-199...	°C	1	Hi	270
AI4	1	1	VR18	Channel4		4553.6	-199...	°C	1	Hi	700
AI5	1	1	VR18	Channel5		4553.6	-199...	°C	1	Hi	1459
AI6	1	1	VR18	Channel6		4553.6	-199...	°C	1	Hi	1412
AI7	1	1	VR18	Channel7		4553.6	-199...	°F	1	Hi	1421
AI8	1	1	VR18	Channel8		4553.6	-199...	°F	1	Hi	1932
AI9	1	1	VR18	Channel9		4553.6	-199...	°F	1	Hi	518
AI10	1	1	VR18	Channel10		4553.6	-199...	°F	1	Hi	1292
AI11	1	1	VR18	Channel11		4553.6	-199...	°F	1	Hi	2652
AI12	1	1	VR18	Channel12		4553.6	-199...	°F	1	Hi	2572
AI13	1	1	VR18	Channel13		455.36	-199...	%	2	Hi	80.0
AI14	1	1	VR18	Channel14		455.36	-199...	%	2	Hi	80.0
AI15	1	1	VR18	Channel15		455.36	-199...	%	2	Hi	80.0
AI16	1	1	VR18	Channel16		455.36	-199...	%	2	Hi	80.0
AI17	1	1	VR18	Channel17		455.36	-199...	%	2	Hi	80.0
AI18	1	1	VR18	Channel18		455.36	-199...	%	2	Hi	80.0
Math1	1	1	VR18	Channel19		3276.7	-327...		1	No	
Math2	1	1	VR18	Channel20		3276.7	-327...		1	No	
Math3	1	1	VR18	Channel21		3276.7	-327...		1	No	
Math4	1	1	VR18	Channel22		3276.7	-327...		1	No	
Math5	1	1	VR18	Channel23		3276.7	-327...		1	No	
Math6	1	1	VR18	Channel24		3276.7	-327...		1	No	
Math7	1	1	VR18	Channel25		3276.7	-327...		1	No	
Math8	1	1	VR18	Channel26		3276.7	-327...		1	No	
Math9	1	1	VR18	Channel27		3276.7	-327...		1	No	

24. Now, Real time viewer should run in PC. If there is successful communication between PC and VR18 via PC-W and Wireless access point AP, then in PC-W, the LED status will be as follows

- COM1: T & R – Flashing
- WLAN: Flashing
- RUN: Flash

### 5.7.3. Paperless Recorder VR18 to PC via Wireless Ethernet (Using 2 PC-W devices)

If existing wireless AP is overloaded with many connected devices, it may affect performance of data transfer between VR18 and PC via wireless Ethernet. In this case, it is suggested to use PC-W as wireless AP also such that you will have dedicated Wireless Ethernet for factory applications and do not mix up with office setup

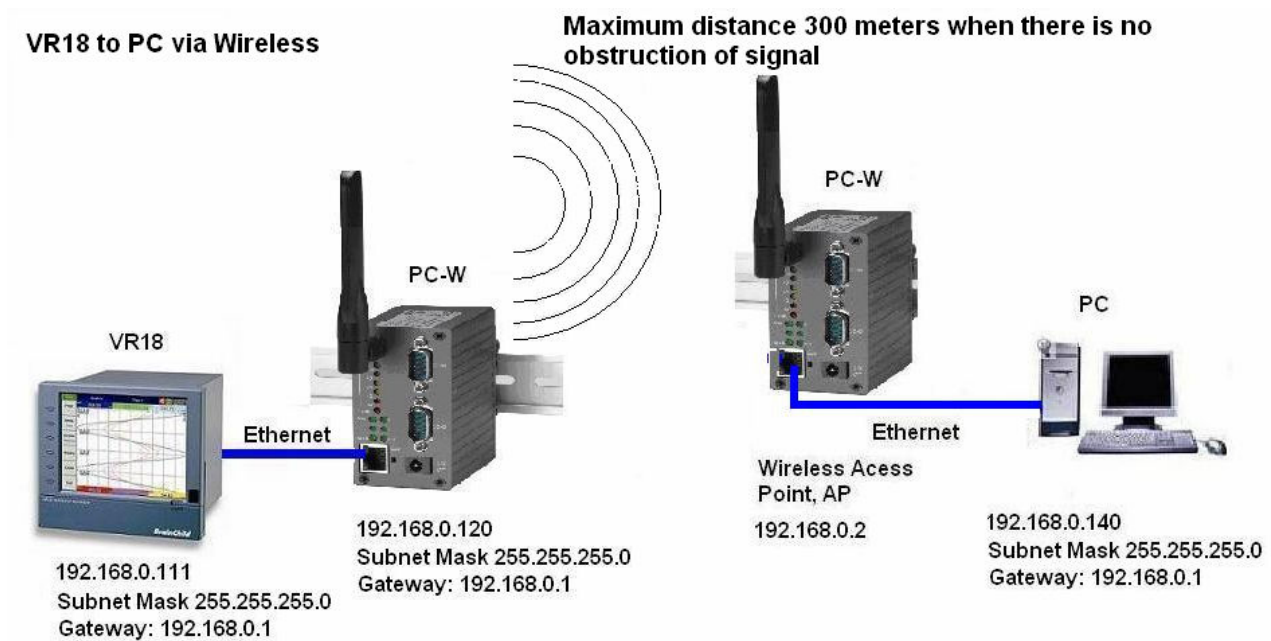

In case of Ethernet connection between VR18 and PC-W, setup is same as procedure explained in section 5.7.1. It requires the additional setup as follows..

SSID should have same ID for both PC-W devices.

Click on “Wireless” and then click on “User define button” as shown attached

http://192.168.0.120/wireless.asp

## Wireless Client Adaptor

- Overview
- Network
- Wireless**
- Serial
- System

### Wireless

There are three buttons in this page.  
 "Rescan": Search wireless AP.  
 "Select" : Start to connect or Change to default.  
 "User Define": Set wireless manually.

Default Information						
SSID	BSSID (AP MAC)	Topology	TxRate	Channel	Encryption	IP Address
(Any)	(Any)	Infrastructure	54.0 Mb/s	Auto	None	192.168.0.120

Current Information						
SSID	BSSID (AP MAC)	Topology	TxRate	Channel	Encryption	Status
3Com	00:0E:6A:D6:9F:BE	Infrastructure	54.0 Mb/s	11	NONE	100%

Rescan

Region: [ Americas ]  
 Wireless Band Mode: [ BG Mixed ]

Select	SSID	BSSID (AP MAC)	Topology	Channel	Encryption	Strength%
<input type="radio"/>	(Any)	(Any)	Infrastructure	1	None	None

Select User Define

Do settings as follows. Please note that these settings should be done at both PC-W devices and settings should be same in both PC-W devices. Ex: SSID number, Topology, Wireless Band, Channel etc.. should be same. Click on "Save settings and Connect" after completing settings

Wireless -- Webpage Dialog

http://192.168.0.120/wireless\_config.asp

## Wireless

### Wireless Setting

Roaming Threshold (%/dBm)  Low (25%/ -80)  Normal (50%/ -70)  High (75%/ -60)

SSID

BSSID (AP MAC)   Enable

Topology    
*Ad-Hoc Mode doesn't support DHCP(Static IP only).*

Wireless Band Mode

TxRate

Channel

Authentication

Encryption

WPA-PSK ( 8 ~ 63 ASCII or 64 HEX )

WEP Key1 Hexadecimal

WEP Key2 Hexadecimal

WEP Key3 Hexadecimal

WEP Key4 Hexadecimal

Apply as Temp & Connect Save Settings & Connect



## Appendix A. Using Virtual COM

**Virtual COM** is a software driver for Microsoft Windows operating system to convert the data in COM port format to IP protocol format, and to transfer the data between the COM port on PC-W device and the IP network. As shown in Fig. 38, by creating Virtual COM ports on a PC, the PC can redirect the communications from the Virtual COM ports over a TCP/IP network to a connection port of a PC-W which is also connected to a Serial device. By using Virtual COM ports, the application running on the PC can send and receive data from the Serial device transparently over the TCP/IP network.

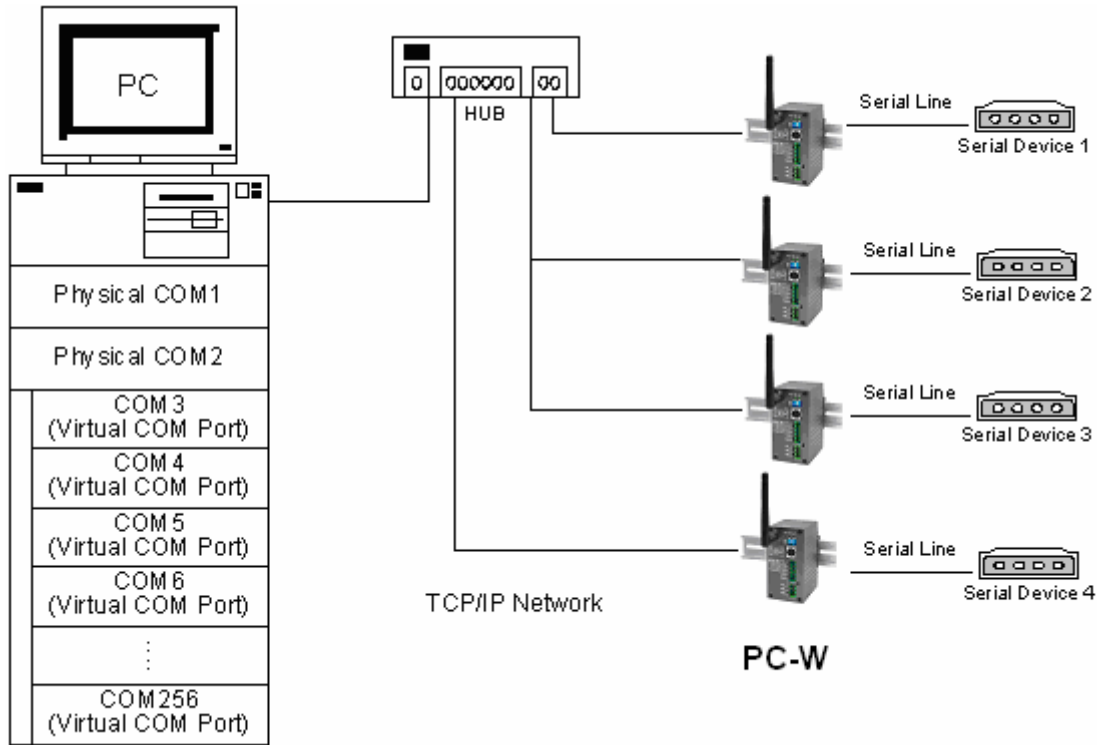

Fig. 38. Setup of a Virtual COM driver

### A.1. Pre-installation Requirements

Please check the operating system on your PC complied with the following requirements:

- Processor: Intel-compatible, Pentium class
- Operation system: Windows Server 2003, Window Vista, Windows XP, Windows 2000, Windows NT 4.0 SP5 or later, Windows Me, Windows 98, Windows 95, Microsoft NT/2000 Terminal Server, Citrix Meta Frame
- Windows Installer 2.0
- Network: Microsoft TCP/IP networking software

### A.2. Limitation and Installation

#### Limitation

Virtual COM driver provides users to select up to 256 COM ports as Virtual COM ports using **Serial Manager** Utility software. Users can select them from a list of COM ports, which is from COM1 up to COM256.



## Installation

Make sure you have turned off all anti-virus software before beginning the installation. Run **VcomXXX.exe** program included in the Product CD to install Virtual COM for your operating system. At the end of the installation, please select one or two COM ports to become the Virtual COM ports.

## Uninstalling

- From Windows Start menu, select Setting\ Control Panel\ Add/Remove Programs.
- Select Virtual COM in the list of installed software.
- Click the Add/Remove button to remove the program, or from Windows Start menu select Programs, Virtual COM, and click Uninstall Virtual COM to remove the program.

## A.3. Virtual COM Communication

### Enable Virtual COM on PC-W by web interface

To access PC-W device from a web browser, typing its IP address in URL location bar, and then click on “Serial” link to access Serial page. On the top half of the page, click on “TCP Server” and enable Virtual COM by putting a check in front of the “Enable” checkbox. Then, type in the local port number in the “Local Port” field as indicated in Fig. 39.

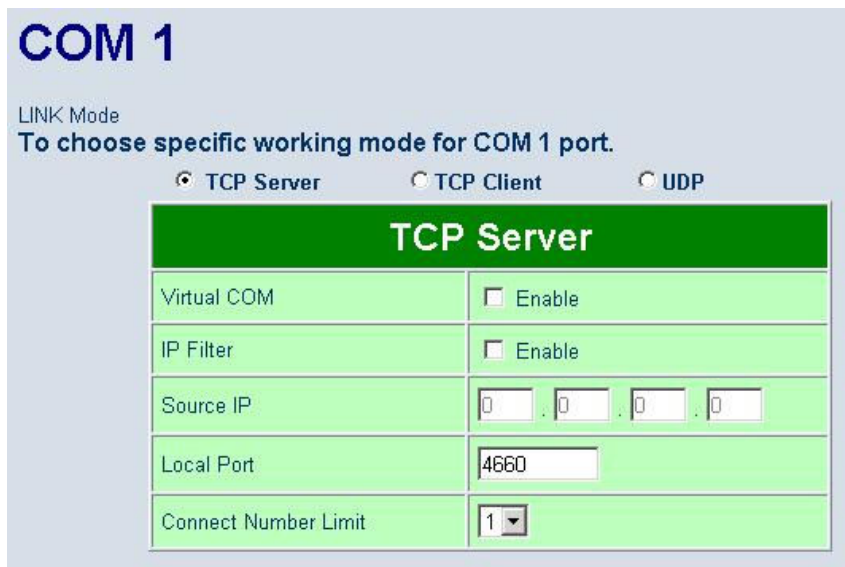

The screenshot shows a web interface for configuring COM 1. At the top, it says "COM 1" and "LINK Mode". Below that, it says "To choose specific working mode for COM 1 port." There are three radio buttons: "TCP Server" (selected), "TCP Client", and "UDP". Below the radio buttons is a green header "TCP Server". Underneath is a table with the following rows:

TCP Server	
Virtual COM	<input type="checkbox"/> Enable
IP Filter	<input type="checkbox"/> Enable
Source IP	<input type="text" value="0"/> . <input type="text" value="0"/> . <input type="text" value="0"/> . <input type="text" value="0"/>
Local Port	<input type="text" value="4660"/>
Connect Number Limit	<input type="text" value="1"/>

Fig. 39. Enable Virtual COM Mode using Web page

### Running Serial to IP for program on PC

On Window Start Menu, go to Program\Serial/IP\Control panel\, The “Serial to IP for Control Panel” window shall appear. Then select the serial port that you want to set up as shown in Fig. 40. On the right of the panel is the sample for COM10 settings. On the left is the list of the COM ports that have been selected for configuration. Change the list by clicking the Select Ports button. Each COM port has its own settings. When clicking on a COM port on the left list, the Control Panel changes to reflect the parameters of the selected port.

**Note: The COM port changes become effective immediately.**

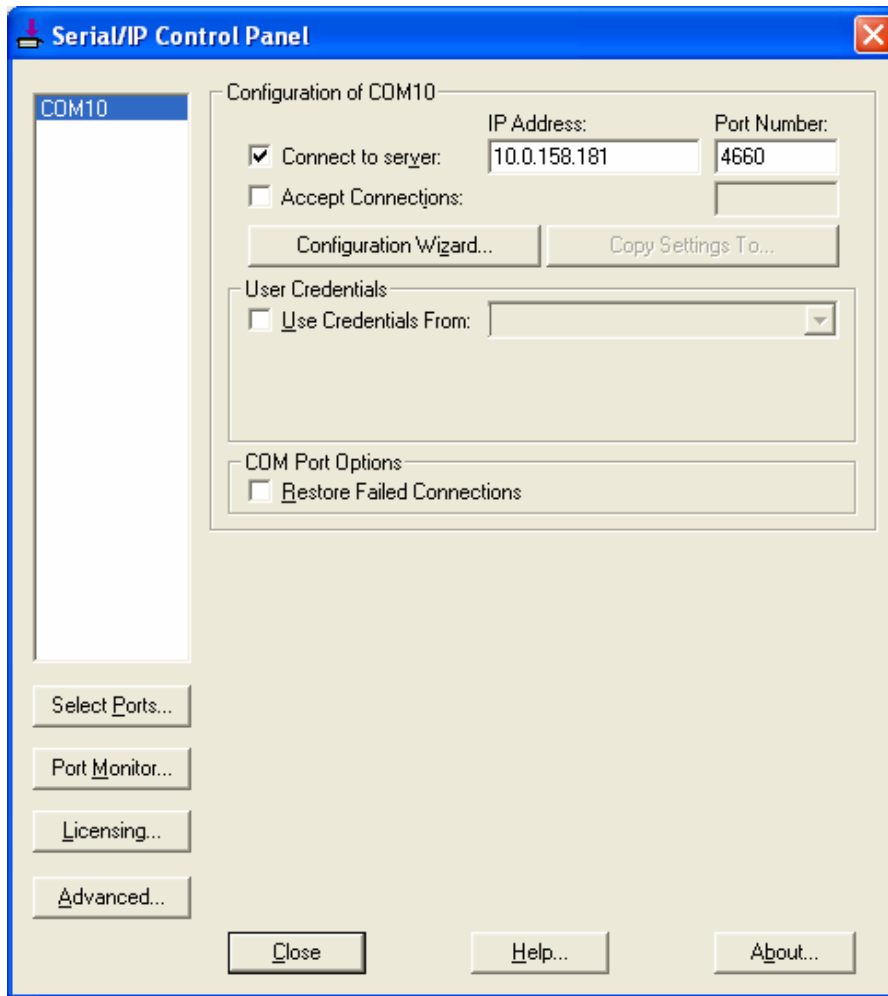

**Fig. 40. Detailed Setting of Serial/IP Control Panel**

### Configure Virtual COM Ports

To configure Virtual COM port as shown in Fig. 40, it can be configured as follows.

- Select a COM port on the list.
- Check “Connected to Server” and enter the PC-W IP address in “IP Address” field.
- In the “Port Number” field, enter the TCP port number of the PC-W. The default port is 4660.
- By default, “User Credentials” is not required. However, if it does require, you will need a username and password to access PC-W device.
- Click “Configuration Wizard” to pop up a dialog to set up a configuration.
- On “Username” and “Password”, the default is no login required. If the PC-W does require the login, you must provide a username and password to access the PC-W device.
- Click the “Start” button that shall appear on the wizard window. This step verifies that the Virtual COM Redirector communicates with the PC-W. If “Log” display does not show any error, click “Use Settings” to apply the settings and return to the Control Panel.
- Settings on the “Connection Protocol” must match the TCP/IP protocol supported by the PC-W. The Configuration Wizard is capable of determining the correct settings.
- On “COM Port Options”, the settings must match the COM port behavior expected by the PC application. The Configuration Wizard will recommend such settings.

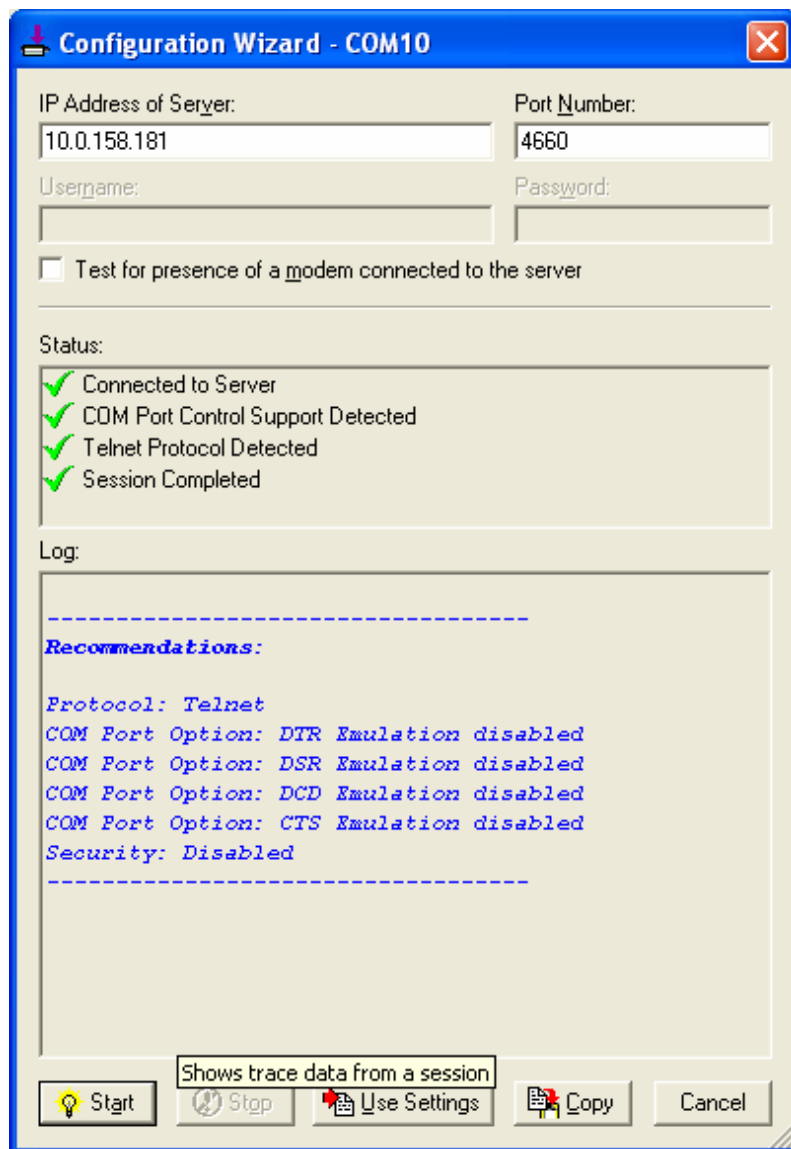

Fig. 41. Configuration Wizard from Serial to IP tool

## Appendix B. Configuration Utility

### B.1. Serial Manager utility Introduction

**Serial Manager** Utility is a special tool for device management and configuration. It can realize the daily management on PC-W devices for address search, device positioning, parameter configuring, and firmware downloading.

### B.2. Interface

The operating interface of the **Serial Manager Utility** is shown below:

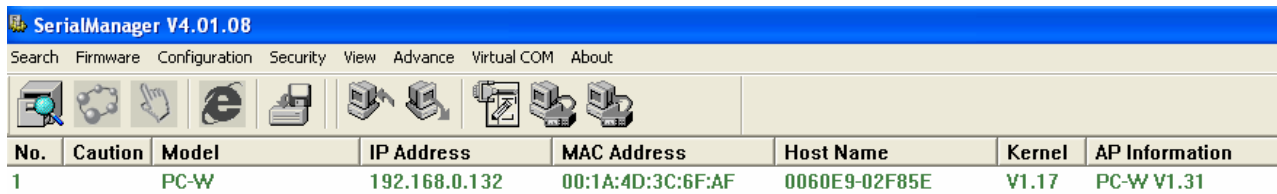

The screenshot shows the SerialManager V4.01.08 application window. The menu bar includes Search, Firmware, Configuration, Security, View, Advance, Virtual COM, and About. The toolbar contains icons for search, configuration, and other functions. Below the toolbar is a table with the following data:

No.	Caution	Model	IP Address	MAC Address	Host Name	Kernel	AP Information
1		PC-W	192.168.0.132	00:1A:4D:3C:6F:AF	0060E9-02F85E	V1.17	PC-W V1.31

### B.3. Functions

#### B.3.1. Device Search

This function is applied to search devices in the network. There are four methods to search devices, Search by Broadcast, Search by IP addresses, Search by MAC addresses and Rescanning devices by using the current search way. To select the search methods, users click the “Search” on the main menu which is shown below.

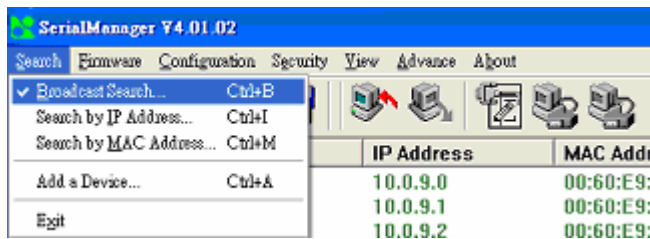

The screenshot shows the SerialManager V4.01.02 application window with the Search menu open. The menu options are: Broadcast Search... (Ctrl+B), Search by IP Address... (Ctrl+I), Search by MAC Address... (Ctrl+M), Add a Device... (Ctrl+A), and Exit. Below the menu is a table with the following data:

	IP Address	MAC Addr
	10.0.9.0	00:60:E9:
	10.0.9.1	00:60:E9:
	10.0.9.2	00:60:E9:

Alternatively, users can select by clicking a button on the toolbar as below.

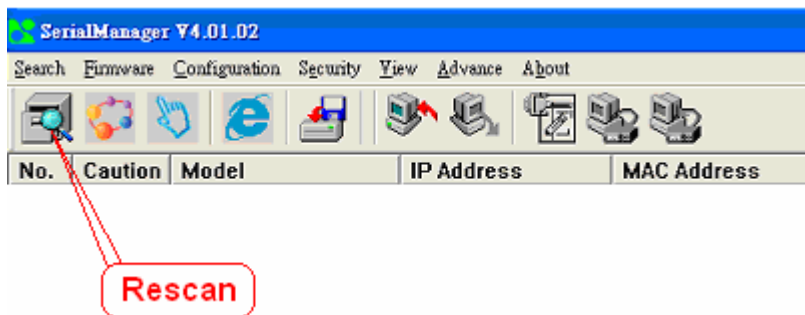

#### Broadcast Search

Once “Broadcast Search” is selected, a box will pop up as below. The user may type in or select different broadcast address based on requirement.



### Search by IP address

Once “Search by IP Address” is selected, an interface will pop up as below. Here user may have two options: Select an IP address to search or Search device in the range of IP address.

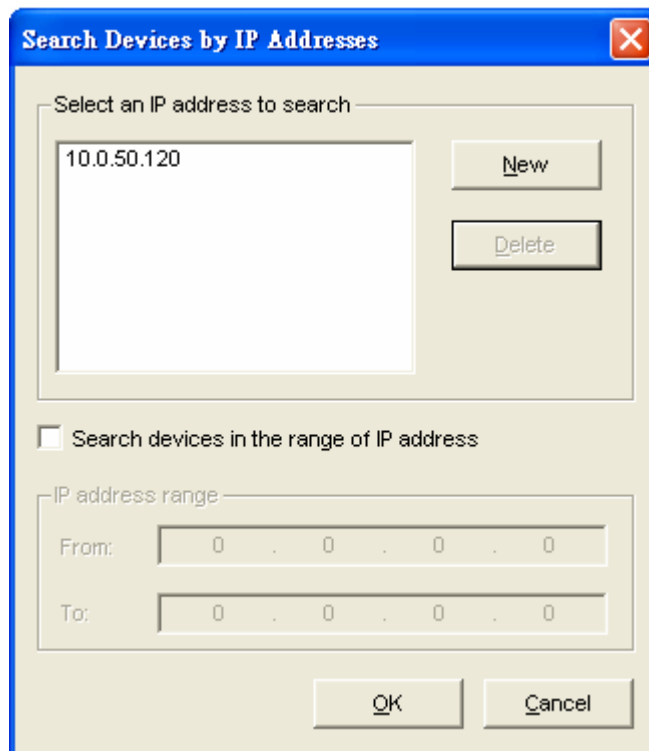

### Search by MAC Address

If “Search by MAC Address” is selected, another box will pop up as below. Here the user may search in two ways: “Search a MAC address to search” or “Search devices in the range of MAC address”

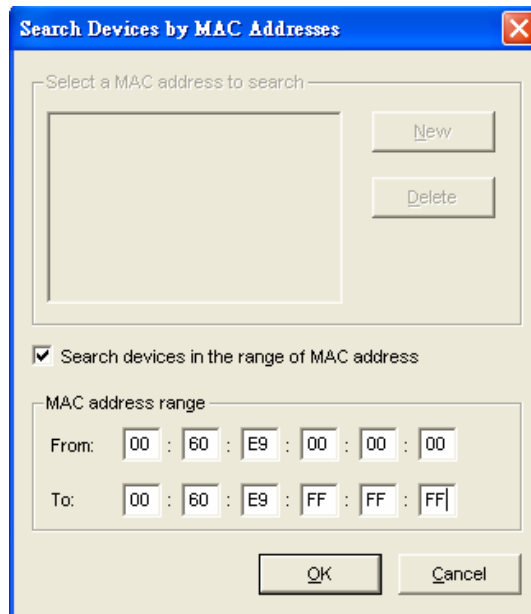

### Rescan

Once the user click the “Rescan” button on the toolbar, the Serial Manager utility shall re-search devices by using the current search way.

### B.3.2. Firmware

This function is applied to downloading a firmware into the selected device. The user can enter the window for downloading by firstly clicking a designated network device, and then selecting the submenu option “Firmware Download” in the main menu option “Firmware”, or directly clicking the button **Upgrade from disk**.

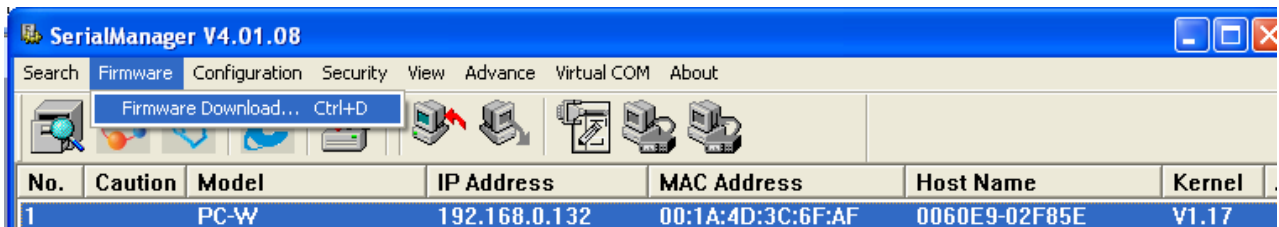

And then the user can select and download the required firmware from the disk, as shown in the figure below. The user can also select several same devices at one time, and realize the firmware updating for them by selecting **Apply for all selected devices have same model**.

Operation Step:

1. Select device (Holding the [Ctrl] key for multiple selection)
2. Click the [Upgrade from disk] icon
3. Click [Upgrade] to apply for all of selected devices



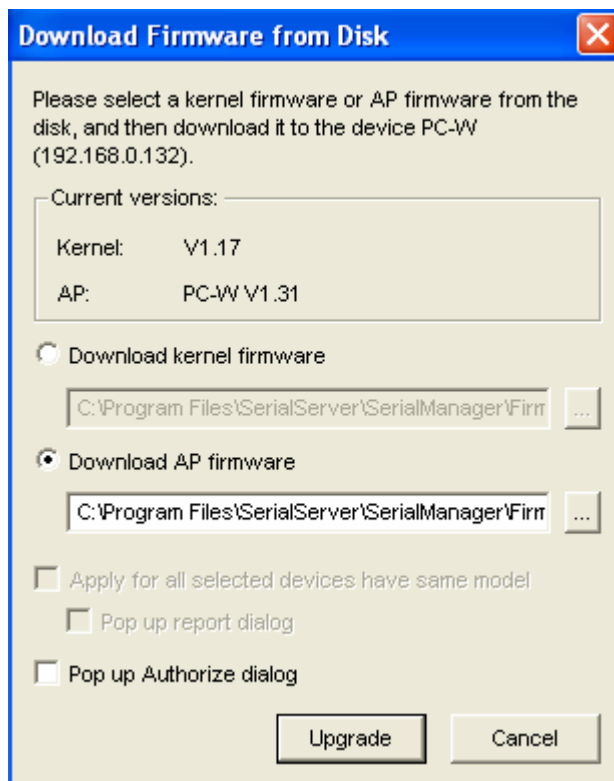

You may want to save device's parameters before upgrading a firmware, and then it can be downloaded to the device after upgrading. Alternatively, you can configure one device and save device's parameters to be downloaded to other devices of the same model. In some devices with JFFS2 file system supported, the user can download the values of related parameters into the device that supports the JFFS2 file system through a submenu **Download Parameter**. See details as the figure below.

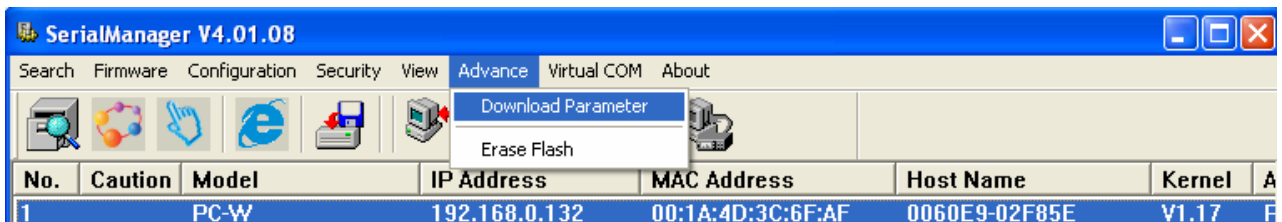

A Dialog is opened and prompted for users to browse and to select a parameter file to be downloaded to devices as shown below.

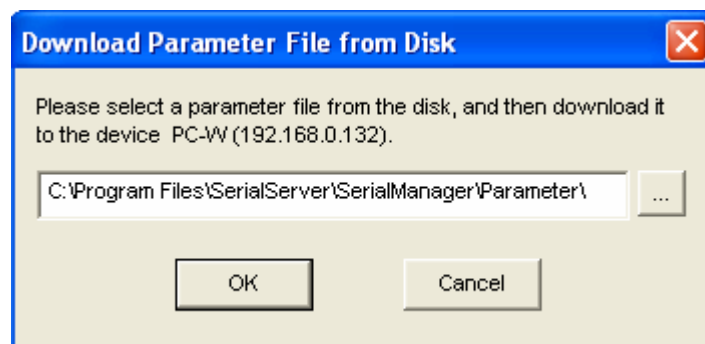

### B.3.3. Configuration

This function is for device configuration to set up parameters, to import and to export the parameters, and to set up some options. Here is the list of configurations: "Network", "SNMP", "COM Port", "Locate", "Reset", "Import Setting", "Export Setting", "Virtual COM", "Config by browser" and "Options." Users can carry out a configuration operating through menu or by clicking the corresponded button on the toolbar, shown as the figure below:

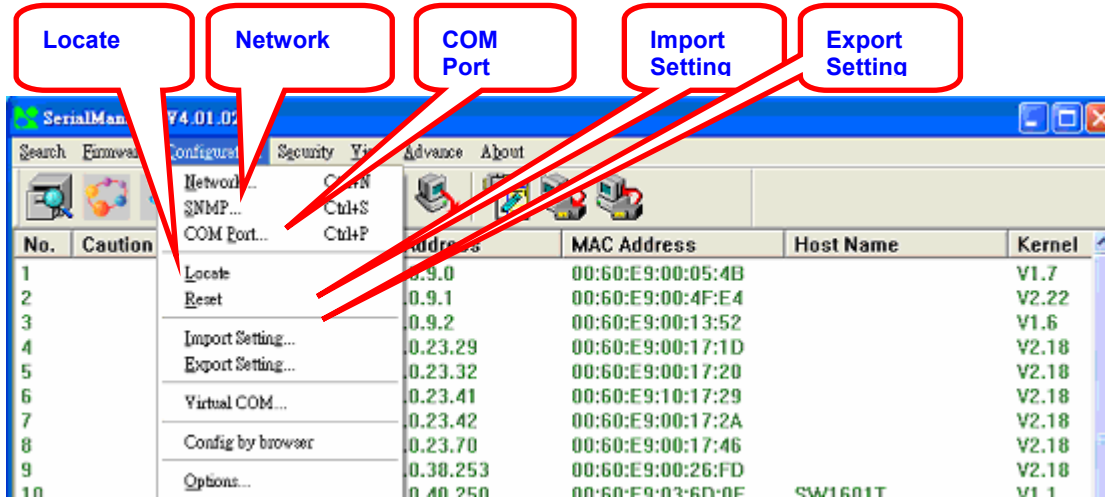

### Network

The user can modify the IP address of any selected device, shown as the figure below. You can statically assign IP address, Subnet mask, and Gateway. Optionally, you can set up the device with a host name. You can select DHCP option to obtain an IP address automatically.

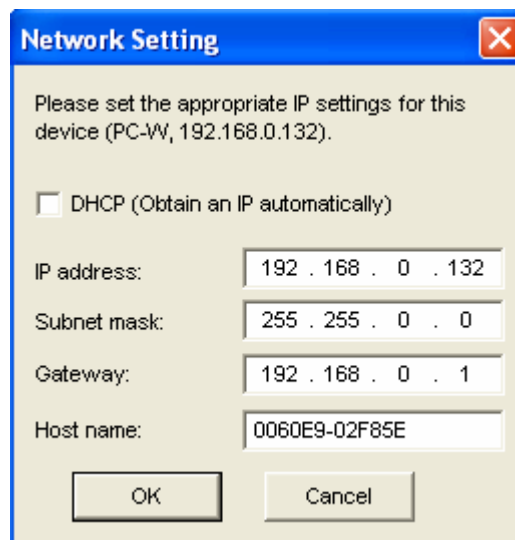

The user can also select several devices at one time, and save the parameter information of these selected devices into a designated parameter file by selecting "Save all the selected devices".



## Configure by Browser

Some devices are supplied with build-in Web servers, which will be used to configure similar to Serial Manager software. Users can carry out any parameter setting directly through the submenu option “Config by Browser”, and a Web browser is shown in the figure below.



## Option

The option is mainly applied to setting some common working rules of Serial Manager utility, such as the device search time interval or whether to display any device information tip. The dialog is shown in the figure below.

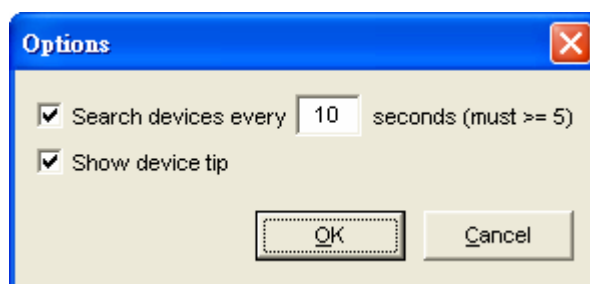

### B.3.4. Security

This function is applied to the security protection for the network devices, so as to supply some necessary protection to a device for configuration modifying, configuration leading-in and leading-out, and some other important functions. Here three functions are mainly supplied, including: **Login**, **Logout** and **Change Password**, shown in the figure below.

## Login

This function is applied to the login to any network device, as some important devices can only be operated after a successful login, shown in the figure below. The user can also select several devices at one time, and log into them at the same time by selecting “Apply for all selected devices.”



Enter a user name and password to login to this device.  
Note: This function is only available for the standard Serial Server.

Device: PC-W IP:192.168.0.132

User Name: admin

Password:

Apply for all selected devices

Login Cancel

## Logout

This function is applied to the logout from any network device, as the user should always carry out a logout after he/she has finished the operating action to any important device, shown in the figure below. The user can also select several devices at one time, and log out them at the same time by selecting “Apply for all selected devices.”

### B.3.5. View

The user can select a display mode of the network device according to his/her own requirement through the menu option "View", such as: display in sequence of device module name, or display in sequence of IP address and so on, shown in the figure below.

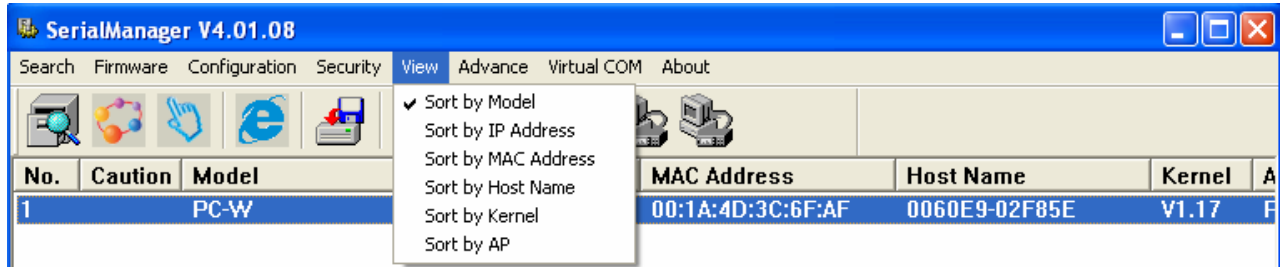

### B.3.6. About

This function is mainly applied to displaying information of the **Serial Manager** utility

## Appendix C. Upgrading System Software

For updated version of a device firmware, please contact your supplier. You may use serial Manager software to upgrade a firmware. Please refer to Serial Manager Firmware Download sectionCritical Issues in Upgrading Process

If the upgrading is successful, PC-W shall re-program the flash memory, and the buzzer will beep before restarting. It takes around 5 seconds to complete the re-programming. **If any error occurs during the process, PC-W will clear the corresponding memories, and the system will remain the same as the one before the upgrading process.**

## Appendix D. Specifications

### D.1. Hardware Specifications

<b>System</b>	
CPU	150 MHz RISC Processor with MMU support
Memory	Flash: 8 MB, 2 MB for Bootloader SDRAM: 16 MB
Interface	Mini-PCI Slot (for Wireless Module)
Watchdog	Hardware Watchdog Reset
Debug Port	CPU Build in COM port
<b>Wireless LAN</b>	
Hardware	Compliance to IEEE 802.11b/g Standard Modulation Type: CCK, DQPSK, DBPSK, OFDM (11g)
Topologies	Infrastructure and Ad-Hoc
Security	WEP 64-bit/128-bit data encryption WPA Compatible (TKIP/AES Encryption) WPA2-PSK
RF Performance	Tx Power: 14 dBm for 802.11b and 13 dBm for 802.11g Rx Sensitivity: -66 dBm @ 54 Mbps, -80 dBm @ 11Mbps Transmission Rate: 54 Mbps (max.) with auto fallback Transmission distance: Up to 300 meters @12 Mbps, in open areas Mobile for Fast Roaming
Interfaces	Reverse SMA connector for an external antenna
<b>Network</b>	
Hardware	10/100M Auto-Negotiation Fast Ethernet
Interface	RJ-45 Connector with 2 LEDs Protection: Built-in 1.5 KV magnetic isolation
Configuration	Using Web-based or a Serial Manager program
<b>Serial</b>	
Protocol	Support RS-232/ RS-485/ RS-422 and Software Selection
Interface	D-Sub 9-pin Connector –DB Model (with 12KV ESD)
Parameters	Baud Rate: 1200 bps ~ 921 kbps Parity Check: None, Odd, Even, Mark, Space Data Length: 7/8 Bit Stop Bit: 1/2 Flow Control: None, Software: Xon/Xoff, Hardware: RTS/CTS
<b>Power</b>	
Input	DC 9V-48V
Consumption	4.5 W max @ Tx Mode
<b>Mechanical</b>	
Dimensions	H x W x D: 90mm x 45mm x 75mm

Casing Metal Housing for IP50 Standard

### Environmental

Operating Temperature 0 to 65°C (32 to 140°F), 5 to 95% RH  
 Storage Temperature -20 to 85°C (-4 to 185°F), 5 to 95%RH

### Regulatory Approvals

EMC FCC/CE  
 Safety UL  
 Warranty 5 Years

## D.2. Software Specifications

### Software

Protocol ICMP, IP, TCP, UDP, DHCP Client, Telnet, DNS, SNMP, HTTP, SMTP, SNTP

---

Utility Virtual COM Utilities for Windows 98/2000/XP/2003/Vista  
 Configure Utilities: Supported for Windows 98/2000/NT/XP/2003/Vista

Configuration Web browser  
 Windows utility software

Buffer Size TCP receiving buffer size = 8K bytes  
 TCP transmitting buffer size = 16K bytes  
 RS-232/RS-485 receiving buffer size = 4K bytes  
 RS-232/RS-485 transmitting buffer size = 4K bytes

## D.3. Pin Assignments

### D.3.1. DB9 male connector pin assignments for Serial port

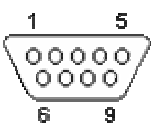
DB9				
	Pin#	RS-232	RS-485	RS-422
	1	DCD		
	2	RXD		T+
	3	TXD	Data+	R+
	4	DTR		
	5	SG (Signal Ground)		
	6	DSR		
	7	RTS	Data-	R-
	8	CTS		T-
	9	RI		

## D.4. Beep & LED Status

### D.4.1. Startup status

Message	Description
^==^=====^^^ (5sec)	Startup OK and application firmware is enabled

Note: Buzzer indication: “^” : Beep twice “=” : Beep off

#### D.4.2. Wireless Signal Strength status

The Access Point link quality can be detected by LED indicator on PC-W. In a running mode, once press a default key and then release, one of the specified actions below shall be performed depending on the released time after you heard how many beeps. The Access Point radio link quality is indicated by the number of LEDs lid on as shown in the table below.

#### Radio Link Quality LED Message

○ Off   ● On   ⚡ Blinking

Operations		Status*	LED1	LED2	LED3	LED4	LED5
<b>Connecting</b>	Search AP (sequentially blinking)	⚡	⚡	⚡	⚡	⚡	⚡
	Connected AP/ Get assigned IP	⚡	●	●	●	●	●
	Not matched SSID	⚡					
	Not available IP	⚡	●				
<b>Connected</b>	Signal Strength is less 20%	●					
	Bad Signal Strength (20%)	●	●				
	Poor Signal Strength (40%)	●	●	●			
	Fair Signal Strength (60%)	●	●	●	●		
	Good Signal Strength (80%)	●	●	●	●	●	
	Excellent Signal Strength (100%)	●	●	●	●	●	●

**Note: The lowest LED is indicated for STATUS on the PC-W's front plate.**

#### D.4.3. WLAN LED Message

Message	Description
LED Off	No data is transmitting on Ethernet
LED Blinking	Data is transmitting on Ethernet

#### D.4.4. COM Port LED Message

Message	Description
LED off	No data is transmitting on COM port
LED Blinking	Data is transmitting on COM port

#### D.4.5. RUN LED Message

Message	Description
LED Blinking (0.5 sec interval)	AP firmware is running