

CONTENTS

- 1. Overview
 - 1.1 Introduction
 - 1.2 Ordering Code
 - 1.3 Front Panel
- 2. Installation
- 3. Modbus Communication
 - 3.1 Modbus Functions Supported
 - 3.2 Modbus Exception Responses
 - 3.3 Modbus Parameter Table
 - 3.4 RTU Communication Examples
- 4. Operation
 - 4.1 ONLINE
 - 4.2 CODE
 - 4.3 Alarm Output
- 5. Specification

1. Overview

1.1 Introduction

DL200 is a data logger which can connect up to 247 Network Temperature Controllers Model NC200. This unit can write all commands and read all data to and from each Network Temperature Controllers Model NC200 after equipping the unit with a HMI or PC via RS-232 port. The unit provides a dry contact which will be closed when one or more of the Network Temperature Controllers Model NC200 are outside of high and low limits or hardware failure occurs.

1.2 Ordering Code

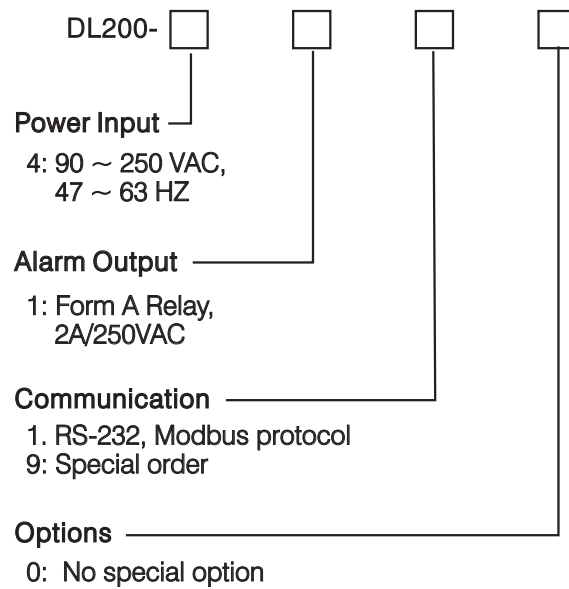

Standard ordering code = DL200-4110

1.3 Front Panel

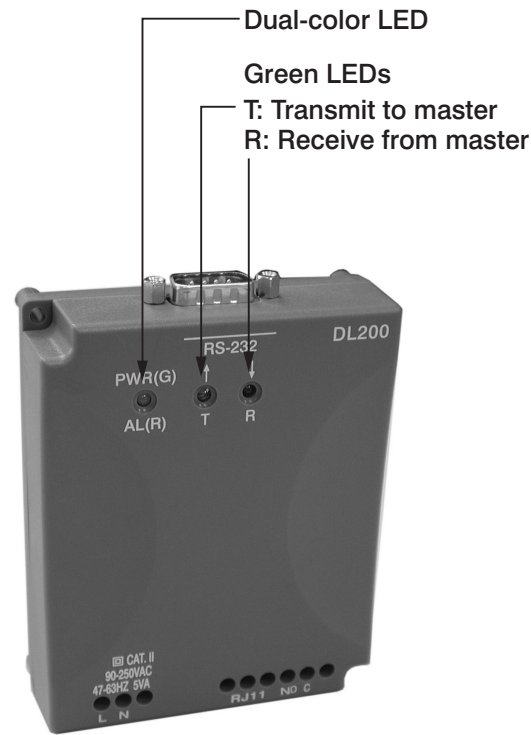

Figure 1 Front Panel Description

The dual-color LED on the front panel provides following status:

Green: All the controllers in the network are within their temperature limits and no failure exist.

Red: One or more of the controllers are outside of high and low limits, or hardware failure exist.

Off: Power is not supplied.

Two green LEDs on the front panel will be flashing when data are being received from HMI or transmitted to HMI or PC via RS-232 port.

2. Installation

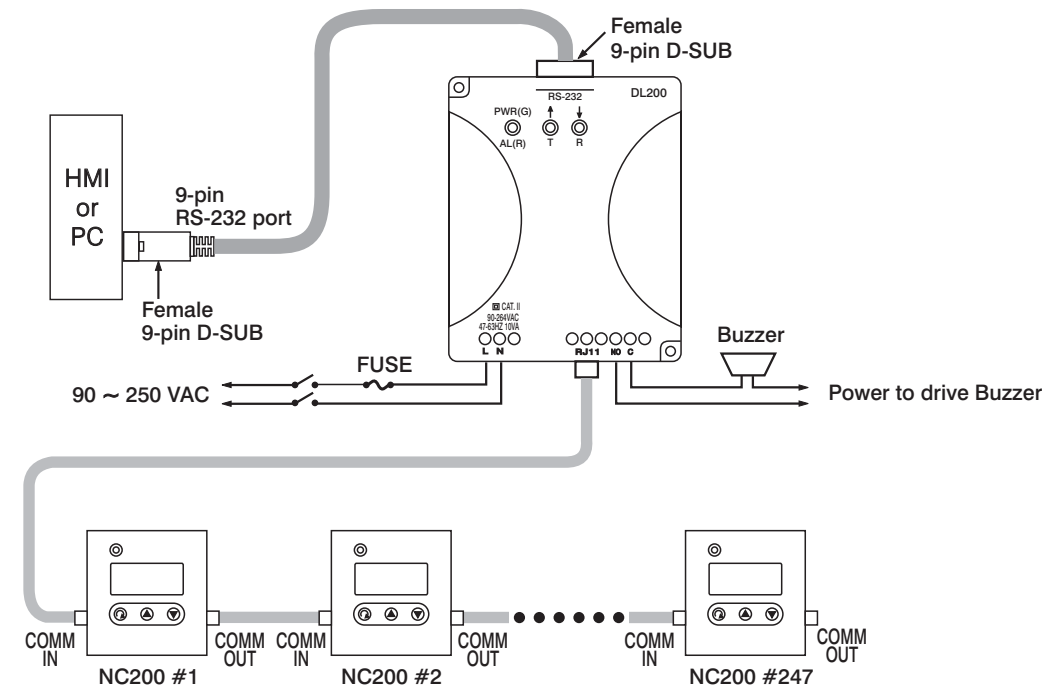

Figure 2 System Wiring

In addition to two screw holder located at two corners of the housing for wall mount installation, a DIN rail clamper provided on the bottom side of the housing for DIN rail mount installation.

3. Modbus Communication

3.1 Modbus Functions Supported

Only function 03, 06 and 16 are available for this unit. The message formats for each function are described as follows:

Function 03: Read Holding Registers

Query (from master)	Response (from slave)
Slave address (20)	←
Function code (3)	←
Starting address of register Hi	Byte count
Starting address of register Lo	Data 1 Hi
No. of words Hi (0)	Data 1 Lo
No. of words Lo (1-127)	Data 2 Hi
CRC16 Hi	Data 2 Lo
CRC16 Lo	⋮
	CRC16 Hi
	CRC16 Lo

Function 06: Preset single Register

Query (from master)	Response (from slave)
Slave address (0, 20)	←
Function code (6)	←
Register address Hi	←
Register address Lo	←
Data Hi	←
Data Lo	←
CRC16 Hi	←
CRC16 Lo	←

Function 16: Preset Multiple Registers

Query (from master)	Response (from slave)
Slave address (0, 20)	←
Function code (16)	←
Starting address of register Hi	←
Starting address of register Lo	←
No. of words Hi (0)	←
No. of words Lo (1-10)	←
Byte count (2-20)	←
Data 1 Hi	CRC16 Hi
Data 1 Lo	CRC16 Lo
Data 2 Hi	
Data 2 Lo	
⋮	
CRC16 Hi	
CRC16 Lo	

3.2 Modbus Exception Responses

If the unit receives a message which contains a corrupted character (parity check error, framing error etc.), or if the CRC16 check fails, the unit ignores the message. However, if the unit receives a syntactically correct message which contains an illegal value, it will send an exception response, consisting of five bytes as follows:

slave address + offset function code + exception code + CRC16 Hi + CRC16 Lo

Where the offset function code is obtained by adding the function code with 128 (ie. function 3 becomes H'83), and the exception code is equal to the value contained in the following table:

Exception Code	Name	Cause
1	Bad function code	Function code is not supported by the controller
2	Illegal data address	Register address out of range
3	Illegal data value	Data value out of range or attempt to write a read-only or protected data

3.3 Modbus Parameter Table

Parameter notation	Parameter description	Register address for read function (Hex)*1	Register address for preset function (Hex)*2	Data range	Data type
SP1	Set point value for control	0001~00FF	0100~FF00	-17 °C~500 °C	R/W
ALH	High alarm set point	0101~01FF	0101~FF01	ALF=0~2: 25 ~ 500 °C ALF=3~5: 5 ~ 40 °C	R/W
ALL	Low alarm set point	0201~02FF	0102~FF02	ALF=0~2: 0 °C ~ ALH -5 °C ALF=3~5: -40 °C ~ -5 °C	R/W
IN	Input sensor type	0301~03FF	0103~FF03	0~2	R/W
ALF	Alarm function	0401~04FF	0104~FF04	0~5	R/W
SHI	PV shift value	0501~05FF	0105~FF05	-100 °C ~ 100 °C	R/W
PB	Proportional band	0601~06FF	0106~FF06	1 ~ 500 °C	R/W
TI	Integral time	0701~07FF	0107~FF07	1 ~ 900 sec.	R/W
TD	Derivative time	0801~08FF	0108~FF08	0~ 300 sec.	R/W
PL	Power Limit value	0901~09FF	0109~FF09	0 ~ 100	R/W
ONLINE*3	Total devices on line	0A00		1 ~ 255	R
PV	Process value	0A01~0AFF		-17 °C ~ 500 °C	R
SV	Set point value	0B01~0BFF		-17 °C ~ 500 °C	R
MV	Control output value	0C01~0CFF	0116~FF16	0 ~ 100	R/W
STA*4	Status word	0D01~0DFF		0000 ~ 030F	R
ADLO*5	Voltage calibration low coefficient		010A~FF0A	-1999 ~ 1999	W
ADHI*5	Voltage calibration high coefficient		010B~FF0B	-1999 ~ 1999	W
RTDL*5	RTD calibration low coefficient		010C~FF0C	-1999 ~ 1999	W
RTDH*5	RTD calibration high coefficient		010D~FF0D	-1999 ~ 1999	W
CJLO*5	Cold junction calibration low coefficient		010E~FF0E	-1999 ~ 1999	W
CJHI*5	Cold junction calibration high coefficient		010F~FF0F	-1999 ~ 1999	W
CODE*6	Security code		0111~FF11	1 ~ 900	W
CMND*7	Command code		011C~FF1C	-32768 ~ 32767	W
JOB*5	Job code for calibration		011D~FF1D	-32768 ~ 32767	W

Table 1. Modbus Parameter Table

- *1: The unit number is stored in low byte of register address for read function.
- *2: The unit number is stored in high byte of register address for preset function.
- *3: The ONLINE parameter specifies the total number of good devices on line detected by DL200.
- *4: The status word STA is defined as follows:

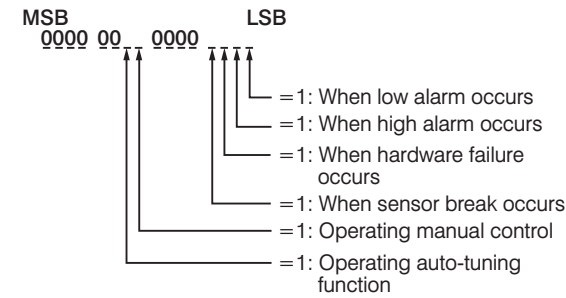

- *5: These are the parameters for sensor calibration and can only be used during production in factory.
- *6: The up-down key function is allowable if and only if CODE=666.
- *7: The command code is defined as follows:

CMND = 0x6825 to perform reset function
 CMND = 0x6827 to perform manual control function
 CMND = 0x6828 to perform auto-tuning function

3.4 RTU Communication Examples

The communication port of the master must be set according to the following values:

Slave address = 20
 Baud rate = 38.4 K
 Parity = even
 Stop bit = 1

Table 2. Allowable function code table for various operation

Operation	Single register single unit	Single register multiple (or all) units	multiple registers single unit	multiple registers multiple (or all) units
Allowable function code	03 (e.g.1) 06 (e.g.3)	03 (e.g.2) 06 (e.g.4)	16 (e.g.5)	16 (e.g.6)

- e.g.1. Read SP1 of unit 3
Query should be :
14 03 00 03 00 01
- e.g.2. Read PV of unit 1 to unit 60
Query should be :
14 03 0A 01 00 3C
- e.g.3. Preset IN = 1 to unit 90
Query should be :
14 06 5A 03 00 01
- e.g.4. Preset CODE = 666 to all units
Query should be :
00 06 XX 11 02 9A
- e.g.5. Preset SP1=150 °C, ALH=25 °C, ALL=-10 °C, IN=1 to unit 3
Query should be :
14 10 03 00 00 04 08 00 96 00 19 FF F6 00 01
- e.g.6. Preset SP1=150 °C, ALH=25 °C, ALL=-10 °C, IN=1, ALF=3, SHI=0, PB=19, TI=60, TD=20, PL=100 to all units (Broadcast function)
Query should be :
00 10 xx 00 00 0A 14 00 96 00 19 FF F6 00 01 00 03 00 00 00 13 00 3C 00 14 00 64

4. Operation

4.1 ONLINE

The parameter ONLINE specifies the total number of good devices on the network detected by DL200. If the value of ONLINE is less than the expected number of installation units, a communication failure occurs. The ONLINE is a read only parameter and its address is at 0A00 (Hex).

4.2 CODE

The parameter CODE is a security code for each NC200 unit. The CODE can be written (but can't be read) by a master. If the CODE is set to 666 for a NC200 unit, all the parameters of the unit can be changed, otherwise, all the parameters of the unit can't be changed by using the key operation.

4.3 Alarm Output

DL200 has a relay output for alarm. The alarm output is energized when the low byte of status word STA of any NC200 unit on the network is not zero.

5. Specification

Power

90~250 VAC, 47~63 Hz, 3VA, 1W maximum

Alarm

Alarm Relay: Form A, Rating 2A/240VAC, life cycles 200,000 for resistive load.
 Alarm Function: low alarm or high alarm or hardware failure or sensor break occurs for any unit on line.
 Alarm Indicator: Red color

Interface

Master Side: RS-232
 Slave Side: RS-422

Data Communication

Master Side:

Protocol: Modbus Protocol RTU Mode
 Address: 20 (fixed)
 Baud Rate: 38.4 Kbits/sec
 Data Bit: 8 bits
 Parity Bit: Even
 Stop Bit: 1 bit
 Reading Speed: 60ms for reading one word of data for 100 units, 480ms for reading 4 words of data for 200 units.

Slave Side:

Interface: Differential driver/receiver
 Protocol: Proprietary protocol
 Baud Rate: 92.16 Kbits/sec
 Reading Speed: 4ms/unit (reading 14 words per unit)
 Writing Speed: 3.5 ms for writing 10 words
 1.5 ms for writing 1 word.

Environmental & Physical

Operating Temperature: -10°C ~ 50°C
 Storage Temperature: -40°C ~ 60°C
 Humidity: 0 ~ 90 % RH (non-condensing)
 Altitude: 2000 m maximum
 Insulation Resistance: 20 Mohms min. (at 500 VDC)
 Dielectric Strength: 2300VAC, 50/60Hz for 1 minute
 Vibration Resistance: 10-55 Hz, 10m/s² for 2 hours
 Shock Resistance: 200 m/s² (20g)
 Dimensions: 102.5 (L) X 80 (W) X 30 (H) mm
 Weight: 120 grams

Approval Standards

Safety: EN61010-1

Protective Class: IP20

EMC: EN61326