



Product Training

Type Code

Control Cabinet Controllers and Drives

Vol.
2



1	MOVIDRIVE®	4
1.1	Description.....	4
1.2	MOVIDRIVE® MDX60B/61B type designation.....	6
1.3	MOVIDRIVE® MDR60B/61B type designation.....	7
2	MOVIAXIS®	8
2.1	Description.....	8
2.2	Structure of the nameplate.....	8
2.3	Nameplate of the axis module.....	9
2.4	Nameplate of the supply module.....	9
2.5	Type designation of MOVIAXIS® basic units.....	10
2.6	Type designation for MOVIAXIS® optional components.....	11
3	MOVITRAC® B	12
3.1	MOVITRAC® B – compact, versatile and universal.....	12
3.2	Type designation.....	12
3.3	Nameplate.....	13
4	MOVITRAC® LTE-B	14
4.1	Technology.....	14
4.2	Product designation.....	14
5	MOVITRAC® LTP-B	15
5.1	Product designation.....	15
6	Asynchronous AC Motors	16
6.1	Description of DR. and EDR. series AC motors.....	16
6.2	Nameplate of a DRE gearmotor with brake.....	17
6.3	Type designation of a DR. series AC brakemotor... ..	17
6.4	Nameplates of EDR. motors.....	18
6.5	Type designations of EDR. motors.....	19
6.6	Description of DRL asynchronous servomotors.....	20
6.7	Overview of types of the DR. motor series.....	21
7	Synchronous Servomotors	25
7.1	CMP / CMPZ motors.....	25
7.2	CMDV motors.....	28
7.3	CMS electric cylinders.....	29
7.4	SL2 synchronous linear motors.....	31
8	Synchronous Servo Gearmotors	35
8.1	Description.....	35
8.2	Nameplate of servo gearmotors.....	35
8.3	Type designation.....	36
9	Gear Units and Adapters	37
9.1	Description of R, F, K, S, W gear units.....	37
9.2	Variants and options of R, F, K, S, W gear units.....	37
9.3	Nameplate/type designation.....	41
9.4	Description of BS.F, PS.F, PS.C gear units.....	42
9.5	Variants and options of BS.F, PS.F and PS.C gear units.....	43
9.6	Nameplate / type designation.....	44
9.7	Components on the input side.....	45
9.8	Description of gear units for electrified monorail systems.....	46



10	Industrial Gear Units.....	47
10.1	X.. series.....	47
10.2	MC.. Series.....	52
10.3	P002 – P082 series.....	55



1 MOVIDRIVE®

1.1 Description

MOVIDRIVE® MDX60B/61B is the new generation of drive inverters from SEW-EURODRIVE. The new MOVIDRIVE® B series inverters feature a modular design, provide enhanced functions in the lower power range, more basic functions, and greater overload capacity.

AC drives with the latest digital inverter technology can now be used without restrictions in the 0.55 to 315 kW power range. The levels of dynamic performance and control quality that can now be achieved with MOVIDRIVE® for asynchronous AC motors were previously only possible using servo drives or DC motors. The integrated control functionality and the option to extend the drive using technology and communication options creates drive systems that are designed to be particularly cost-effective regarding application range, project planning, startup and operation.

Product family

The **MOVIDRIVE®** product family includes three series:

- **MOVIDRIVE® MDX60B:** Drive inverter for asynchronous AC motors without encoder feedback. The units are not option-capable.
- **MOVIDRIVE® MDX61B:** Drive inverter for asynchronous AC motors with or without encoder feedback, or for asynchronous and synchronous servomotors. The units are option-capable.
- **MOVIDRIVE® MDR60A/61B:** Regenerative power supply unit; MOVIDRIVE inverters (400/500 V units) operate in regenerative mode to feed energy back into the supply system.

MOVIDRIVE® MDX61B unit series, sizes 0 to 7

The following figure shows MOVIDRIVE® MDX61B drive inverter sizes 0 to 7



3193709067

MOVIDRIVE® MDR60A/61B unit series, sizes 2 to 7

The following figure shows MOVIDRIVE® MDX61B regenerative power supply units, sizes 2 to 7



1454307595

Unit variants

MOVIDRIVE® MDX60/61B size 0-6 inverters are available in two variants, namely the standard variant and the application variant. MOVIDRIVE® MDX60B/61B size 7 inverters are only available as application variants with coated pcbs (-0T/L).

Standard variant

The units are equipped with integrated IPOS^{plus}® positioning and sequence control as standard. MOVIDRIVE® MDX61B can be expanded with the available options.

"00" at the end of the type designation indicates the standard variant.

Application variant

In addition to the features of the standard variant, these units include the technology functions "electronic cam" and "internal synchronous operation". Furthermore, you can use all the application modules available in the MOVITOOLS® MotionStudio engineering software with the application variants.

The application variant is indicated by "0T" following the type designation.

Variants with coated printed circuit boards

The units are designed for use in harsh environments. The coating of the printed circuit boards increases their resistivity against environmental conditions.

The variant with coated pcbs is indicated by "00/L" or "0T-/L" at the end of the type designation.



1.2 MOVIDRIVE® MDX60B/61B type designation

System nameplate size 0

The **system nameplate** of MDX60B/61B size 0 is attached to the side of the unit.

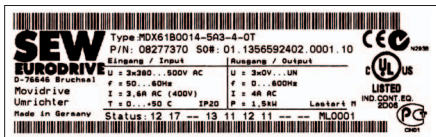

1799724171

System nameplate sizes 1 - 7

The **system nameplate** is attached to MDX61B.. as follows:

- On the side of the units of size 1-6
- On the upper front cover of size 7



1799730315

Type designation

The following diagram shows the type designation of the MOVIDRIVE® MDX60/61B inverter:

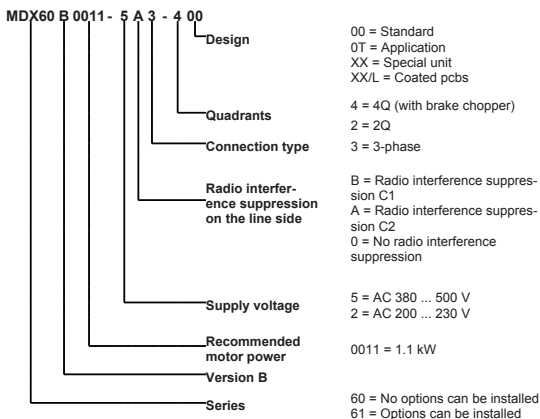



1.3 MOVIDRIVE® MDR60B/61B type designation

Nameplate

The nameplate is attached to the front of the unit.



EN 55011 B
VDE 0558

SEW EURODRIVE
D-76646 Bruchsal
NETZRUCKSPEISUNG
MOVIDRIVE
Made in Germany

Typ MDR60A0750-503-00
Sach. Nr. 8265569
Eingang / Input
U = 3*380...500V +/-10%
f = 50...60Hz
I = 117A AC (400V)
T = 0...45 C

Serien Nr. 00080
Ausgang / Output
U = 560...780V DC
I = 167A DC
IP00 P = 94kVA



1877000715

Type designation

The following diagram shows the type designation of the MOVIDRIVE® MDX60/61B regenerative power supply unit:

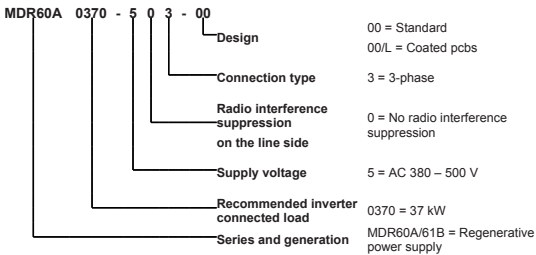



2 MOVIAXIS®

2.1 Description

MOVIAXIS® multi-axis servo inverters have been designed for compact machine and plant automation systems at the highest stage. Productivity and intelligence are combined in an ideal way, allowing for a wide range of applications.

2.2 Structure of the nameplate

The nameplate is divided into up to 3 parts depending on the module.

- Part "I" of the nameplate indicates the type designation, production number and status.
- Part "II" of the nameplate indicates the factory-installed options and the version status.
- Part "III" of the nameplate (system nameplate) contains the technical data of the module.

The **system nameplate** is located on the side of the unit for the supply module and axis module.

The nameplate contains a description of the version and the scope of supply of the multi-axis servo inverter at the time of delivery.

There may be deviations if

- E.g. option cards are installed or removed at a later time
- or if the unit firmware is updated.

Location of the nameplate

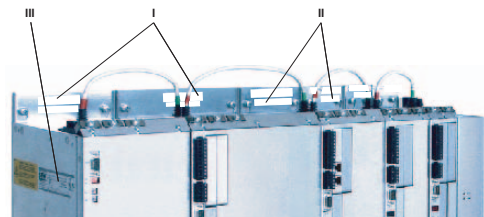

1402316683

- I Part "I" of the nameplate
- II Part "II" of the nameplate
- III Part "III" of the nameplate (system nameplate)



2.5 Type designation of MOVIAXIS® basic units

The following diagram shows the type designation:

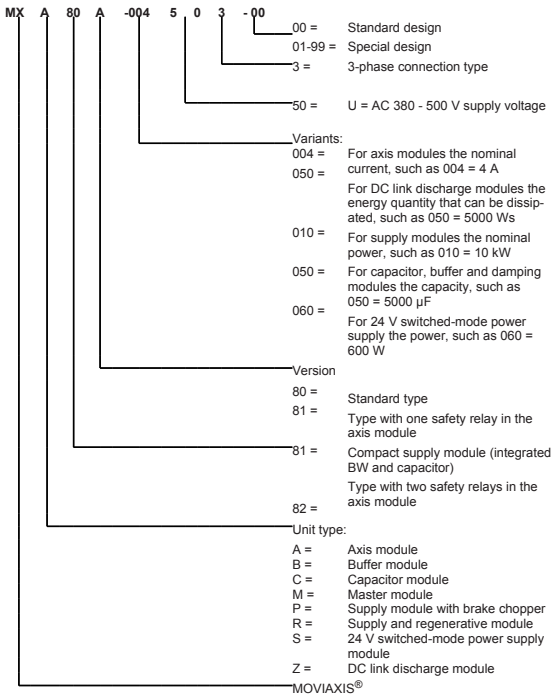

Type designation for the axis module:

MXA80A-004-503-00 = Axis module with 4 A nominal current

Type designation for the buffer module component

MXB80A-050-503-00 = Buffer module with a capacity of 5000 µF

Type designation for additional damping module component

MXD80A-007-503-00 = Damping module with a capacity of 700 µF

Type designation for the capacitor module component

MXC80A-050-503-00 = Capacitor module with a capacity of 5000 µF

Type designation for master module with fieldbus gateway component:

MXM80A-000-000-00/UFF41B = Master module with PROFIBUS/DeviceNet

MXM80A-000-000-00/UFR41B = Master module with EtherNet/IP / PROFINET Modbus/TCP



Type designation for master module with controller component:

- MXM80A-000-000-00/DHF41B/OMH41B = Master module with PROFIBUS/DeviceNet
 MXM80A-000-000-00/DHR41B/OMH41B = Master module with EtherNet/IP / PROFINET Modbus/TCP
 Variants: T0 – T25

Type designation for the supply module:

- MXP81A-010-503-00 = 10 kW compact supply module with integrated C and BW
 MXP80A-010-503-00 = 10 kW supply module
 MXR80A-075-503-00 = 50/75 kW supply and regenerative module

Type designation for the 24 V switched-mode power supply module component

- MXS80A-060-503-00 = 24 V switched-mode power supply module

Type designation for the DC link discharge module component:

- MXZ80A-050-503-00 = DC link discharge module with an energy quantity of 5000 Ws that can be dissipated

2.6 Type designation for MOVIAXIS® optional components

The following diagram shows the type designation:

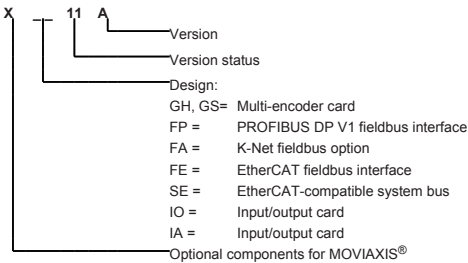



3 MOVITRAC® B

3.1 MOVITRAC® B – compact, versatile and universal

The percentage of speed-variable AC drives with inverter technology is constantly increasing and these units offer all options to optimize system and machine concepts to the process sequences in addition to machine-conserving drive technology. The expanse of these different fields of application shows that it is difficult to meet the technological and economic requirements with one universal inverter class.

The drive electronics in asynchronous AC motors are separated into standard inverters, for simple applications, e.g. materials handling, and application inverters, for more complex technological applications, e.g. positioning and handling applications. This differentiation of the units makes for scaling to different applications while staying with a certain budget.

Operation, parameter setting, diagnostics and integration in automation concepts must offer unit-comprehensive and therefore universal engineering and communication support. Engineering tools for project planning, parameter setting and startup as well as the availability of communication interfaces (fieldbuses and Industrial Ethernet) offer users a solution-oriented and unit-independent user interface.

3.2 Type designation

The following diagram shows a type designation:

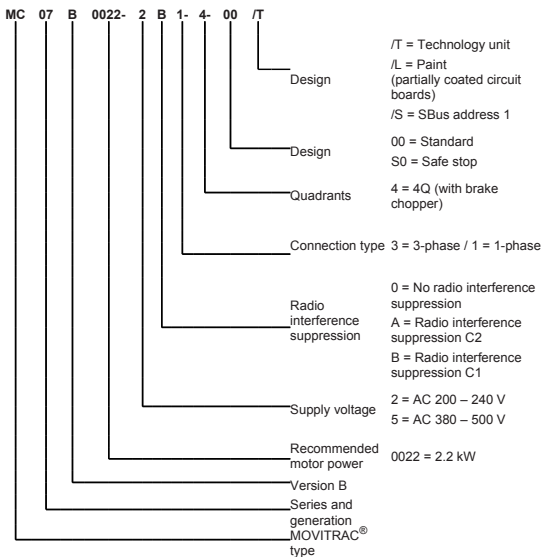



3.3 Nameplate

The following figure shows a nameplate:

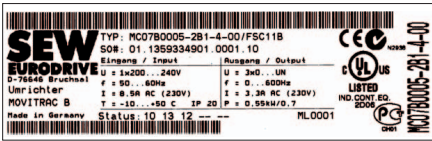

3185547659

Input	U	Nominal line voltage
	I	Nominal line current, 100% operation
	f	Nominal line frequency
Output	U	Output voltage 100% operation
	I	Nominal output current 100% operation
	f	Output frequency
T		Ambient temperature
P motor		Recommended motor power 100% operation

The unit status for communication with SEW-EURODRIVE is indicated over the bar code at the bottom. The unit status documents the hardware and software states of the unit.



4 MOVITRAC[®] LTE-B

4.1 Technology

The MOVITRAC[®] LTE-B range consists of a series of products in 3 physical sizes designed to provide cost-effective, easy-to-use drives for 3-phase induction motors in the power range 0.37 kW to 7.5 kW.

The MOVITRAC[®] LTE-B uses open loop voltage and frequency control to regulate the speed of the motor. Digital control is combined with the latest IGBT power semiconductor technology to provide a compact, robust solution for general purpose drive applications. The product is designed for ease of use and installation, together with simple programming and commissioning thereby minimizing the overall costs of a drive solution.

4.2 Product designation

MC LTE	1	B	0015	2	0	1	1	00	(60 Hz)		
										60Hz	American version only
											00 = Standard IP20 housing
										Type	10 = IP55 / NEMA 12 housing
											20 = IP55 / NEMA 12 housing with switch
											40 = IP66 / NEMA 4X housing with switch
										Quadrants	1 = 1Q (without brake chopper)
											4 = 4Q
										Connection type	1 = 1-phase
											3 = 3-phase
										Interference suppression on the supply side	0 = class 0
											A = class A
											B = class B
										Line voltage	1 = 115 V
											2 = 200 – 240 V
											5 = 380 – 480 V
										Recommended motor power	0015 = 1.5 kW
										Version	B
										Motor	1 = single phase motors only
										Product type	MC LTE



6 Asynchronous AC Motors

6.1 Description of DR. and EDR. series AC motors

Motor

The asynchronous motor consists of a stator with a three-phase winding and a laminated rotor. The rotor slots are usually lined with aluminum and short-circuited at the front ends using a short-circuit ring. Variants with die-cast copper are also available. The rated speed at supply frequency can be defined by the number of poles.

The main advantages can be described as follows:

- Long service life
- Low maintenance (no brush wear)
- Temporary high overload capacity
- Nearly constant speed (no "overspeed" in no-load operation)
- Comparatively low production costs

The following figure shows an DR.. series AC motor:

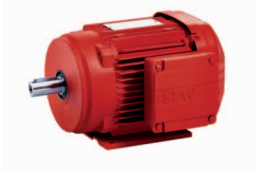

6.2 Nameplate of a DRE gearmotor with brake

The following figure shows an example of a nameplate:

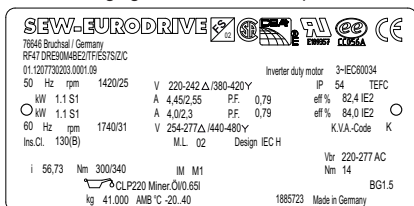

9007201693954571

The marks on the upper edge of the nameplate are only present when the motor has been certified accordingly or when it includes the relevant components.

6.3 Type designation of a DR. series AC brakemotor

The following diagram shows a type designation example:

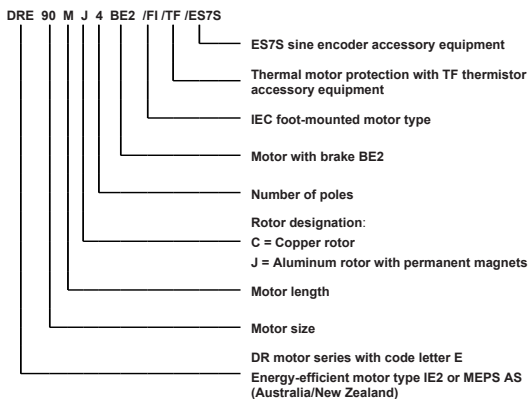



6.4 Nameplates of EDR. motors

EDRE motor in category 2GD

The following figure shows a nameplate:

SEW-EURODRIVE		VIKEX		CE			
76646 Bruchsal / Germany		← 0306-22-J-C3		← 0205-22-J-C3			
EDRE90M4/2GD		PTB 10 ATEX 1234 / 01		0102			
01.1151928301.0001.09		eff % 82,5					
Hz	50	r/min	1430	V	220-240 Δ / 380-420 Y	IA/IN	6,9
kW	1,5	A	3,48	cosφ	0,77	tEs	16
○ kW		A		cosφ		tEs	○
Hz		r/min		V		IA/IN	
Vbr		IhAC		PTB 10 ATEX 1234 / 02	eff %	86,4	
Nm		II2G Ex e IICT3 Gb		II2D Ex tb IIIC T120°C Db			
		Kundenartikel-Nr.		13A47B911			
IM	B3	IP	65	Iso.Kl.	155 (F)	3-IEC60034-1 Zone A	
kg	19	Ta	-20...+40 °C	UTIL	130 (B)	Jahr	2010
				Made in Germany			

2439213579

The marks on the upper edge of the nameplate are only present when the motor has been certified accordingly or when it includes the relevant components.

EDRE motor with frequency inverter

The following figure shows a nameplate:

SEW-EURODRIVE		Ex		CE	
76846 Bruchsal / Germany				0102	
EDRE90M4 / 2GD		PTB 10 ATEX 1234 / 02X			
01.1151928301.0001.09					
Hz	5	10	25	50	87
r/min	135	225	750	1435	2541
△ V	23	46	129	230	400
A	3	6,2	6,8	6,8	6,8
Nm	2,9	9,8	11,9	11,9	11,9
Y V	40	80	220	400	400
A	2,1	3,6	4	4	2,3
Nm	2,9	9,8	11,9	11,9	6,8
01885626		3-IEC60034		Made in Germany	

9007202350032139



6.5 Type designations of EDR. motors

EDR.. series AC motor

The following diagram shows a type designation:

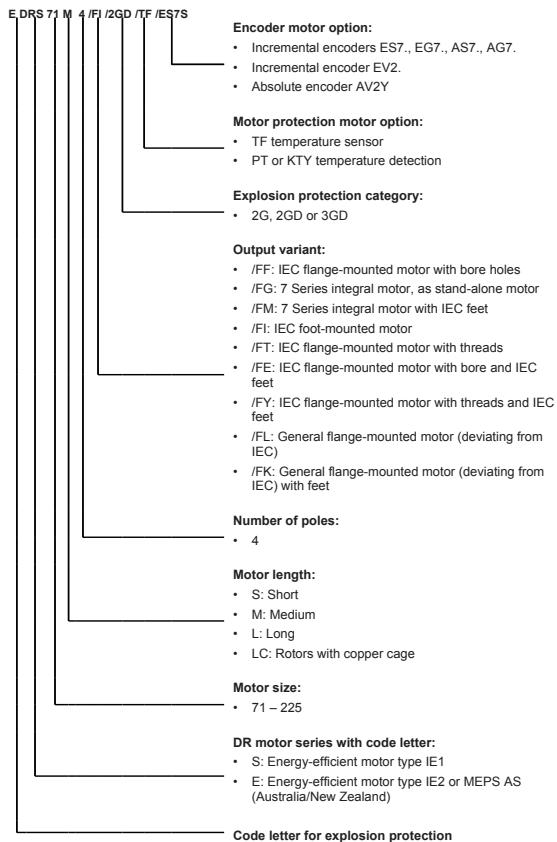



6.6 Description of DRL asynchronous servomotors

Description

Asynchronous servomotors are the link between the classical asynchronous AC motors for supply system and inverter operation and the highly dynamic synchronous servomotors with permanent magnets.



2998238987

DRL motor variants

Asynchronous servomotors of the DRL series are a drive package made up from the many options of the modular DR motor system.

In its basic variant, the drive package always contains

- An encoder, sine signals, and electronic nameplate
- Thermal motor protection
- Dynamics package
- Various connection options
- Winding optimized with respect to speed

Depending on the application and requirements, the following elements can be added:

- Forced cooling fan
- Connection via plug connectors instead of terminals
- Temperature detection
- And many more

Alternatives can be selected instead of the elements of the basic variant, e.g. an absolute encoder instead of the sine encoder.



6.7 Overview of types of the DR. motor series

AC motor series

The following table shows possible AC motor variants:

Designation	
DRS..	Motor, Standard efficiency IE1, 50 Hz
DRE..	Energy-efficient motor, High efficiency IE2, 50 Hz
DRP..	Energy-efficient motor, Premium efficiency IE3, 50 Hz
DRL..	Asynchronous servomotor
DRK.. ¹⁾	Single-phase operation with running capacitor
DRM.. ¹⁾	Torque motor: Torque motor for operation at speed $n = 0$
71 – 315	Sizes: 71 / 80 / 90 / 100 / 112 / 132 / 160 / 180 / 200 / 225 / 315
K – L	Lengths: K= very short / S = short / M = medium / L = long MC/LC = Rotors with copper cage
2, 4, 6, 8/2, 8/4	Number of poles

1) in preparation

Output variants

The following table shows possible output variants:

Designation	Option
/FI	IEC foot-mounted motor with specification of shaft height
/FG	7 Series integral motor, as stand-alone motor
/FF	IEC flange-mounted motor with bore holes
/FT	IEC flange-mounted motor with threads
/FL	General flange-mounted motor (other than IEC)
/FM	7 series integral gearmotor with IEC feet, with specification of shaft height if required
/FE	IEC flange-mounted motor with bore holes and IEC feet, with specification of shaft height
/FY	IEC flange-mounted motor with thread and IEC feet, with specification of shaft height if required
/FK	General flange-mounted motor (other than IEC) with feet, with specification of shaft height if required
/FC	C-face flange-mounted motor, dimensions in inch



Mechanical attachments

The following table shows possible mechanical attachments:

Designation	Option
BE..	Spring-loaded brake with specification of size
HR	Manual brake release of the brake, automatic disengaging function
HF	Manual brake release, lockable
/RS	Backstop
/MSW	MOVI-SWITCH®
/MI	Motor identification module for MOVIMOT®
/MM03 – MM40	MOVIMOT®
/MO	MOVIMOT® option(s)

Temperature sensor / temperature detection

The following table shows possible thermal protection variants:

Designation	Option
/TF	Temperature sensor (positive coefficient thermistor or PTC resistor)
/TH	Thermostat (bimetallic switch)
/KY	One KTY84 – 130 sensor
/PT	One / three PT100 sensor(s)

Encoder

The following table shows possible encoder variants:

Designation	Option
/ES7S /EG7S /EH7S /EV7S	Mounted speed sensor with sin/cos interface
/ES7R /EG7R /EH7R	Mounted speed sensor with TTL (RS-422) interface, V = 9 – 26 V
/EI7C	Mounted speed sensor with HTL interface
/EI76 /EI72 /EI71	Mounted speed sensor with HTL interface and 6 / 2 / 1 period (s)
/AS7W /AG7W	Mounted absolute encoder, RS-485 interface (multi-turn)
/AS7Y /AG7Y /AH7Y	Mounted absolute encoder, SSI interface (multi-turn)
/ES7A/EG7A	Mounting adapter for encoders from the SEW portfolio
/XV.A	Mounting adapter for non-SEW encoders
/XV..	Mounted non-SEW encoders



Connection variants

The following table shows possible connection variants:

Designation	Option
/IS	Integrated plug connector
/ASB.	HAN 10ES plug connector on terminal box with two-clamp closure (cage clamps on motor end)
/ACB.	HAN 10E plug connector on terminal box with two-clamp closure (crimp contacts on motor end)
/AMB. /ABB. /ADB. /AKB.	HAN Modular 10B plug connector on terminal box with two-clamp closure (crimp contacts on motor end)
/ASE.	HAN 10ES plug connector on terminal box with single-clamp closure (cage clamps on motor end)
/ACE.	HAN 10ES plug connector on terminal box with single-clamp closure (crimp contacts on motor end)
/AME. /ABE. /ADE. /AKE.	HAN Modular 10B plug connector on terminal box with single-clamp closure (crimp contacts on motor end)
/KCC	Terminal strip with cage clamps (for DR.71 – DR.132)
/KC1	C1 profile compliant connection of the DR80 electrified mono-rail drive (VDI guideline 3643) (for DR71, 80)

Ventilation

The following table shows possible ventilation variants:

Designation	Option
/V	Forced cooling fan
/Z	Additional inertia (flywheel fan)
/AL	Metal fan
/U	Non-ventilated (without fan)
/OL	Non-ventilated (closed B side)
/C	Protection canopy for the fan guard
/LF	Air filter
/LN	Low-noise fan guard (for DR.71 – 132)

Bearings

The following table shows possible bearing variants:

Designation	Option
/NS	Relubrication device (for DR.315 only)
/ERF	Reinforced bearing A-side with rolling bearing (for DR.315 only)
/NIB	Insulated bearing B-side (for DR.315 only)



Condition monitoring

The following table shows the possible monitoring units:

Designation	Option
/DUB	Diagnostic unit brake = brake monitoring
/DUV	Diagnostic unit vibration = vibration sensor

Explosion-proof motors

The following table shows possible explosion-proof AC motor variants:

Designation	Option
/2GD	Motors according to 94/9/EC, category 2 (gas / dust)
/3GD	Motors according to 94/9/EC, category 3 (gas / dust)
/VE	Forced cooling fan for motors according to 94/9/EC, category 3 (gas / dust)

Other additional features

The following table shows other possible features:

Designation	Option
/DH	Condensation drain hole
/RI	Reinforced winding insulation
/RI2	Reinforced winding insulation with increased resistance against partial discharge
/2W	Second shaft end on the motor/brakemotor



7 Synchronous Servomotors

7.1 CMP / CMPZ motors

Description of CMP motors

The CMP servomotor series combines high dynamics, high torques, and precision in a compact design.

Their innovative design with the latest in winding and magnet technology offers a motor system with optimum dynamics and the best control characteristics at the smallest space. The cast stator protects the motor against vibrations and humidity.

CMP servomotors can be combined with MOVIAXIS[®] multi-axis servo inverters and MOVIDRIVE[®] inverters.



2997677835

Description of CMPZ motors

CMPZ synchronous servomotors are equipped with an internal additional flywheel mass. These motors combine high torques and precision in a compact design and provide particularly favorable control characteristics with high external masses. Furthermore, the internal higher moment of inertia allows for a smaller gear ratio.

In addition to the above mentioned features of the CMP motors, CMPZ motors are optionally available with a powerful working brake with high working capacity and optional manual brake release.



CMP motor nameplate

The following figure shows a nameplate:

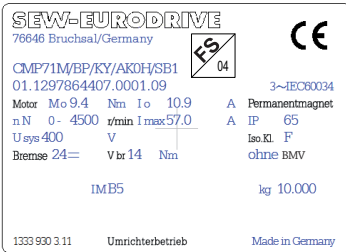

The nameplate only contains the FS logo if safety-rated components are used.

The following figure shows a nameplate with UL, CSA approval:

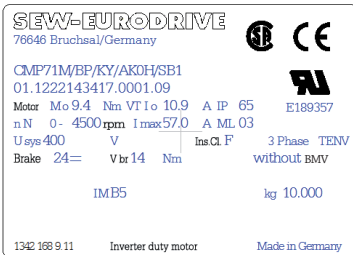

Location of the nameplate.





Type designation of a servomotor

The following diagram shows a type designation:

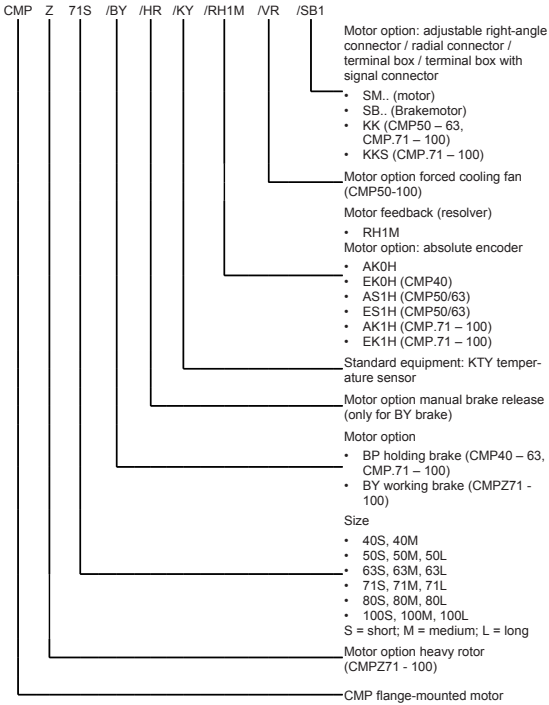

Type designation of plug connectors

The following diagram shows a type designation:

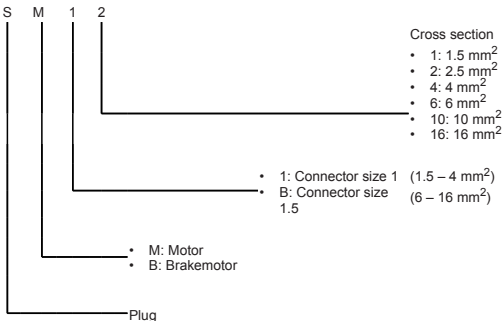



7.2 CMDV motors

Description of CMDV motors

The compact CMDV servomotors come without housing and are convection cooled; they offer standstill torques from 0.3 to 32 Nm with an overload capacity of factor six. The strong bearings and the low-vibration design make these motors the ideal component for applications with small installation spaces and directly powered servo applications.

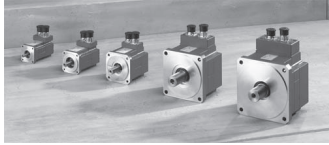

3659907979

CMDV motor nameplate

The following figure shows a nameplate:

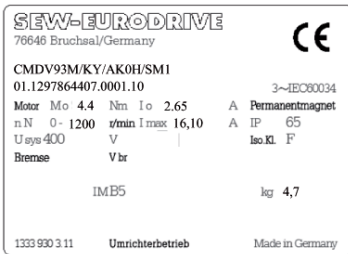

Type designation of a servomotor

The following diagram shows a type designation:

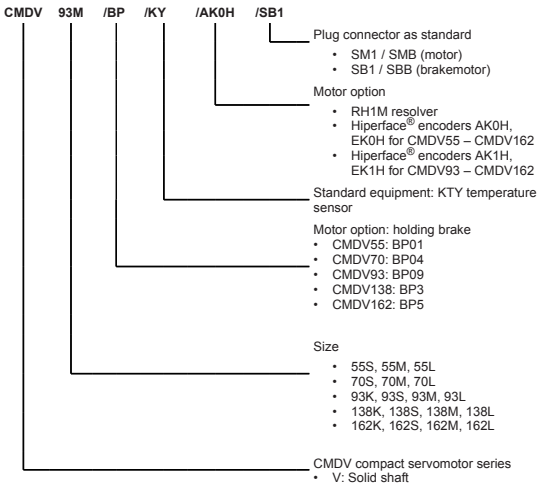



7.3 CMS electric cylinders

Description

Electric cylinders of the CMS series are equipped with permanent magnet rotors and operate particularly precise, powerful and fast. Combined with drive electronics from SEW-EURODRIVE, they provide economical, energy-efficient drive solutions that ensure a high level of process reliability in system operation and are easy to integrate into existing automation facilities, such as welding systems and robotic systems.

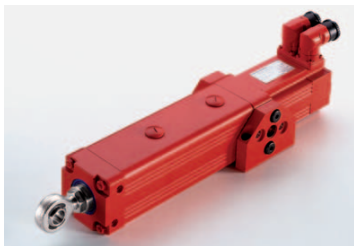

2997873547

Nameplate

The following figure shows a nameplate:

SEW-EURODRIVE		CE	
76646 Bruchsal / Germany			
CMS71L/BS/TF/AS1H/SB1			
01.12345678.01.0001.06		3 - IEC60034	
Motor Mo	9.5 Nm	Io	6.2 A
Fpk	17 kN	Imax	25.0 A
U Sys	400 V	°C	-20...+40
nN	3000 r/min	ne pk	3000 r/min
Bremse	24 Vbr	19 Nm	IM M0
Spindel	KGT p	10 mm/r	Hub 200 m
Fuchs RENOLIT CX-TOM15			
0594 927 0		Umrichterbetrieb	
Made in Germany			

3543587339

Type	Motor type
No.	Manufacturing number
M_o	Standstill torque (thermal continuous torque at a speed of 5 to 50 rpm)
I_o	Standstill current
Fpk	Peak feed force
I_{max}	Maximum permitted motor current
IP	Degree of protection
U Sys	Motor voltage
°C	Ambient temperature range
Insul. cl.	Thermal class
nN	Rated speed
ne pk	Maximum mechanically permitted speed
kg	Weight
Brake	Rated voltage of brake/braking torque
Spindle	Spindle type
P	Spindle pitch
Stroke	Stroke length
IM	Mounting position
	Lubricant



Type designation

The following diagram shows a type designation:

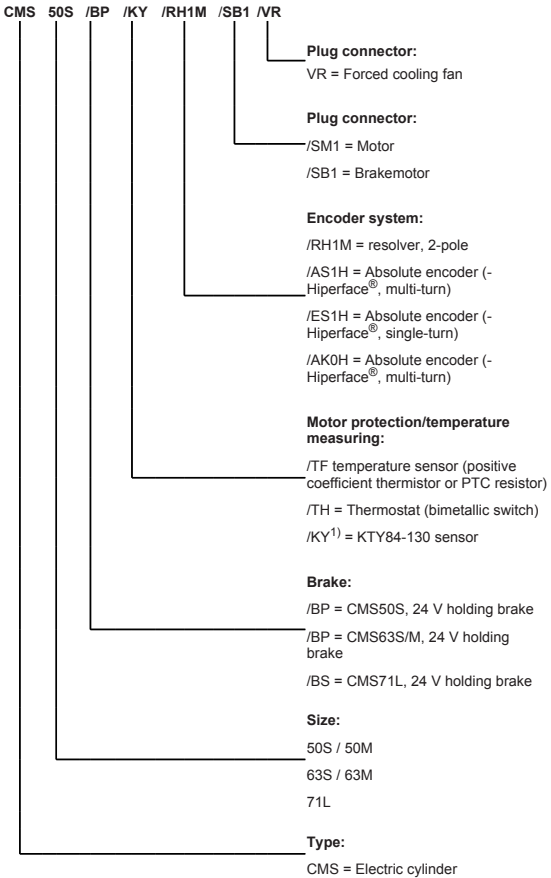

1) of CMS50 and CMS63 is available only with KTY



7.4 SL2 synchronous linear motors

Description



2997988619

SL2 synchronous linear motors are available in three designs for speed classes 1, 3 and 6 m/s (3, 10 and 20 ft/s): SL2 Basic, SL2 Advance System and SL2 Power System. For longer travel distances, secondaries are available in different lengths and can be easily lined up with one another. The SL2 Advance System features a motor cooling unit, which provides even better cooling than SL2 Basic. A forced-air cooling fan gives the SL2 Power System a further power boost.

Nameplate

SL2 Basic

The following figure shows a nameplate:

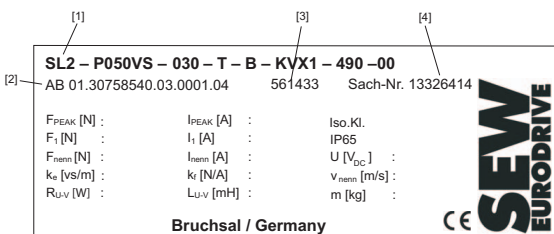

- | | |
|-----------------------------|--|
| [1] = Type code | F_{PEAK} = Peak force |
| [2] = Customer order number | F_1 = Maximum force available up to v_1 |
| [3] = Production number | F_{nenn} = Permanent force |
| [4] = Part number | k_e = Voltage constant |
| | R_{U-V} = Winding resistance ¹⁾ |
| | I_{PEAK} = Maximum current |
| | I_1 = Current at F_1 |
| | I_{nenn} = Nominal current |
| | k_f = Force factor |
| | L_{U-V} = Inductance ¹⁾ |
| | Iso.KL. = Insulating material class |
| | IP = Degree of protection |
| | U = Voltage |
| | m = Mass |
| | v_{nenn} = Velocity up to which the rated force is available |

1) Half the conductor value (UV value) is used for startup.



SL2 Advance System / SL2 Power System

The following figure shows a nameplate:

SEW-EURODRIVE		CE	
76646 Bruchsal/Germany			
Type	SL2-P050S-30-T-P-SSXS-490-00		
No.	01.1234567801.0001.06		
F ^{peak}	1300 N	I ^{peak}	11,8 A kg 12,3
F ₁	1000 N	I ₁	8,7 A IP 54
F _N	760 N	I _N	6,1 A
k _e	76 vs/m	k _f	131 N/A
R _{U-V}	7,0 Ω	L _{U-V}	45,0 mH
U	490 V _{DC}	Ins.Cl.	B
v _N	3,4 m/s	Part-No.	
1332783 6 Made in Germany			

- Type = Type code
 No. = Customer order number
 F^{Peak} = Peak force
 F₁ = Maximum force available up to v₁
 F_N = Permanent force
 k_e = Voltage constant
 R_{U-V} = Winding resistance¹⁾
 U = Voltage
 v_N = Velocity up to which the rated force is available
 I^{PEAK} = Maximum current
 I₁ = Current at F₁
 I_N = Nominal current
 k_f = Force factor
 L_{U-V} = Inductance²⁾
 Ins.Cl. = Insulating material class
 Part-No. = Part number
 kg = Weight
 IP = Degree of protection

1) Half the conductor value (UV value) is used for startup.

2) Half the conductor value (UV value) is used for startup.

Secondary

The following figure shows a nameplate:

[1]	SL2 - S050 - 128	[3]
[2]	AB 01.30758450.03.0002.04	
[5]	Sach-Nr. 13327046	
	561433	[4]

SEW
EURODRIVE
 Bruchsal / Germany

- [1] = Type code
 [2] = Customer order number
 [3] = Date of production
 [4] = Production number
 [5] = Part number



Type designation

Primary

The following diagram shows a type designation:

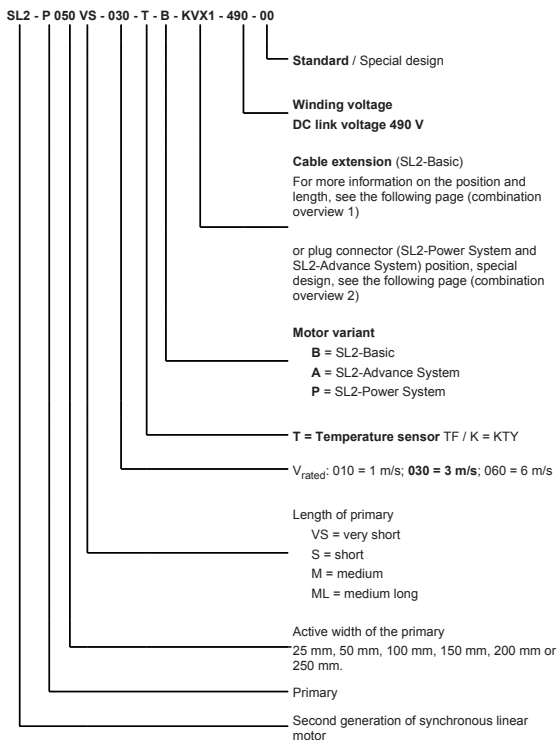

Overview of combinations for SL2 Basic / cable extension

The following diagram shows a type designation:

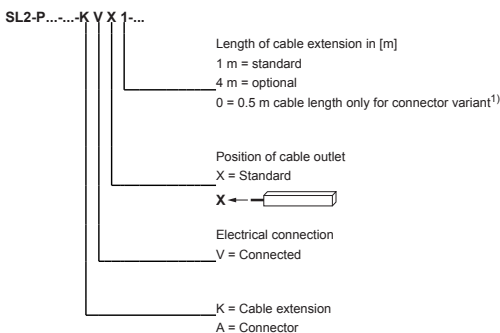

1) Connector version AVX0 refers to a 0.5 m cable extension with prefabricated connector



Combination overview 2 for SL2-Advance and SL2-Power System / connector position

The following diagram shows a type designation:

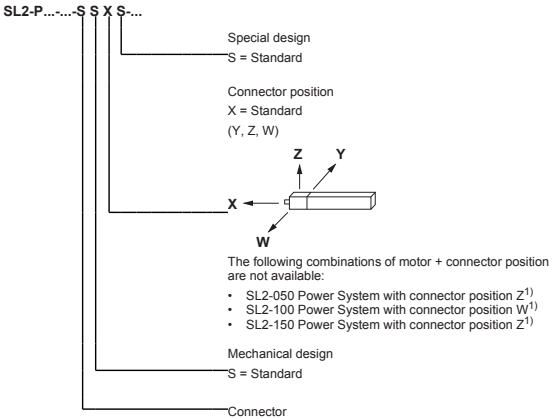

1) Collision with M12 24 V connector

Secondary

The following diagram shows a type designation:

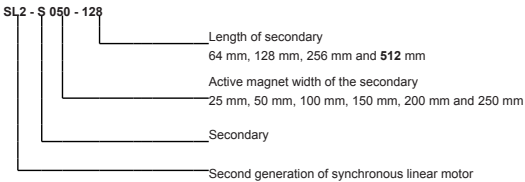



8 Synchronous Servo Gearmotors

8.1 Description

The following figure shows servo gearmotors:

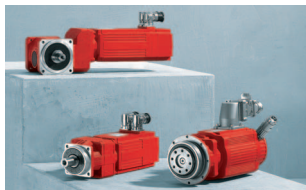

8.2 Nameplate of servo gearmotors

Nameplate for PS.C.. servo gearmotors

The following figure shows a nameplate for a gearmotor:

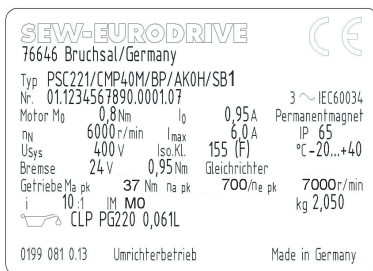

3613171339

i	Gear unit reduction ratio	n_N	[rpm]	Rated speed
IM	Mounting position	M_0	[Nm]	Rated torque
IP	Degree of protection	I_0	[A]	Rated current
n_{epk}	[rpm] Maximum permitted input speed	I_{max}	[A]	Maximum permitted current
n_{apk}	[rpm] Maximum permitted output speed	f_N	[Hz]	Rated frequency
M_{apk}	[Nm] Maximum permitted output torque	V_{max}	[V]	Maximum permitted voltage

The nameplate of servo gearmotors is fixed to the servomotor.



8.3 Type designation

Type designation of PS.C.. servo gearmotors

The following diagram shows a type designation for a gearmotor:

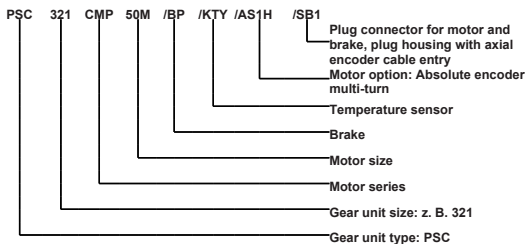



9 Gear Units and Adapters

9.1 Description of R, F, K, S, W gear units

The level of torque and permissible overhung loads is incomparably high in relation to the structural volume of the motor. This was made possible by the compact and extremely rigid housing with its low weight and optimum power flow. The sealing surfaces are free from any load because the force runs through the complete housing.

The shaft-hub connections of all gearmotors are positive to ensure maximum safety in the application. Parallel shaft, helical, and helical-bevel gearmotors are also available with reduced backlash for precise positioning tasks.

The following figure shows R, F, K, S and W gear units:



9.2 Variants and options of R, F, K, S, W gear units

Below an overview of type designations for R, F, K, S, and W gear units and their options.

Helical gear units

The following table shows possible helical gear unit variants:

Designation	
RX..	Single-stage foot-mounted
RXF..	Single-stage B5 flange-mounted
R..	Foot-mounted
R..F	Foot-mounted and B5 flange-mounted
RF..	B5 flange-mounted
RZ..	B14 flange-mounted
RM..	B5 flange-mounted with extended bearing hub



Parallel shaft helical gear units

The following table shows possible parallel shaft gear unit variants:

Designation	
F..	Foot-mounted
FA..B	Foot-mounted and hollow shaft
FH..B	Foot-mounted and hollow shaft with shrink disk
FV..B	Foot-mounted and hollow shaft with splined hollow shaft to DIN 5480
FF..	B5 flange-mounted
FAF..	B5 flange-mounted and hollow shaft
FHF..	B5 flange-mounted and hollow shaft with shrink disk
FVF..	B5 flange-mounted and hollow shaft with splined hollow shaft to DIN 5480
FA..	Hollow shaft
FH..	Hollow shaft with shrink disk
FT..	Hollow shaft with TorqLOC hollow shaft mounting system
FV..	Hollow shaft with splining to DIN 5480
FAZ..	B14 flange-mounted and hollow shaft
FHZ..	B14 flange-mounted and hollow shaft with shrink disk
FVZ..	B14 flange-mounted and hollow shaft with splined hollow shaft to DIN 5480

Helical-bevel gear units

The following table shows possible helical-bevel gear unit variants:

Designation	
K..	Foot-mounted
KA..B	Foot-mounted and hollow shaft
KH..B	Foot-mounted and hollow shaft with shrink disk
KV..B	Foot-mounted and hollow shaft with splined hollow shaft to DIN 5480
KF..	B5 flange-mounted
KAF..	B5 flange-mounted and hollow shaft
KHF..	B5 flange-mounted and hollow shaft with shrink disk
KVF..	B5 flange-mounted and hollow shaft with splined hollow shaft to DIN 5480
KA..	Hollow shaft
KH..	Hollow shaft with shrink disk
KT..	Hollow shaft with TorqLOC hollow shaft mounting system
KV..	Hollow shaft with splining to DIN 5480
KAZ..	B14 flange-mounted and hollow shaft
KHZ..	B14 flange-mounted and hollow shaft with shrink disk
KVZ..	B14 flange-mounted and hollow shaft with splined hollow shaft to DIN 5480



Helical-worm gear units

The following table shows possible helical-worm gear unit variants:

Designation	
S..	Foot-mounted
SF..	B5 flange-mounted
SAF..	B5 flange-mounted and hollow shaft
SHF..	B5 flange-mounted and hollow shaft with shrink disk
SA..	Hollow shaft
SH..	Hollow shaft with shrink disk
ST..	Hollow shaft with TorqLOC hollow shaft mounting system
SAZ..	B14 flange-mounted and hollow shaft
SHZ..	B14 flange-mounted and hollow shaft with shrink disk

SPIROPLAN gear units

The following table shows possible SPIROPLAN gear unit variants:

Designation	
W..	Foot-mounted
WF..	Flange-mounted
WAF..	Flange-mounted and hollow shaft
WA..	Hollow shaft
WA..B	Foot-mounted and hollow shaft
WH..B	Foot-mounted and hollow shaft with shrink disk
WHF..	Flange-mounted and hollow shaft with shrink disk
WH..	Hollow shaft with shrink disk
WT..	Hollow shaft with TorqLOC hollow shaft mounting system



Options

The following table shows possible options for R, F, and K gear units:

Designation	
/R	Reduced backlash

The following table shows possible options for K, S and W gear units:

Designation	
/T	With torque arm

The following table shows possible options for F gear units:

Designation	
/G	With rubber buffer

Condition monitoring

The following table shows possible monitoring units:

Designation	Option
/DUO	Diagnostic Unit Oil = Oil aging sensor
/DUV	Diagnostic Unit Vibration = Vibration sensor



9.3 Nameplate/type designation

Nameplate

The following figure shows a nameplate:

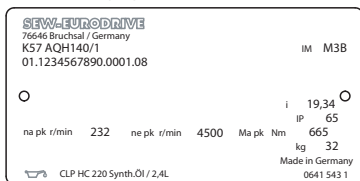

624901899

i		Gear unit reduction ratio
IM		Mounting position
IP		Degree of protection
n_{epk}	[rpm]	Maximum permitted input speed
n_{apk}	[rpm]	Maximum permitted output speed
M_{apk}	[Nm]	Maximum permitted output torque

Type designation

The following diagram shows a type designation:

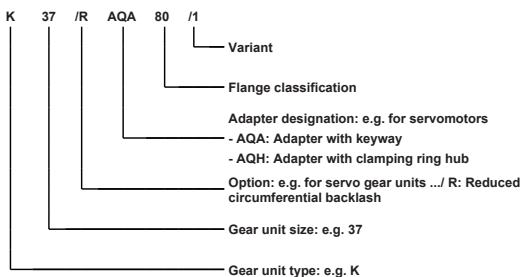



9.4 Description of BS.F, PS.F, PS.C gear units

BS.F, PS.F and PS.C gear units are characterized by higher processing speeds, increased accuracy and faster accelerations. In conjunction with consistently low circumferential backlash, high stiffness, and a high level of efficiency, these highly precise and extremely powerful servo gear units form the basis for a variety of servo gear units.

Servo gear units are also characterized by the following features:

- Direct motor mounting:
Positive direct mounting (without terminal adapter) of the SEW servomotor series CMP, CM and DS
- Motor adapter:
EPH motor adapters for PS.F and PS.C planetary servo gear units, ECH motor adapters for PS.C planetary servo gear units, and EBH motor adapters for BS.F helical-bevel servo gear units.
- Reduced backlash:
Optionally for PS.F planetary servo gear units and BS.F helical-bevel servo gear units with significantly smaller circumferential backlash
- Minimized circumferential backlash:
Optionally for PS.F planetary servo gear units with even more reduced circumferential backlash

The following figures show BS.F and PS.F gear units:

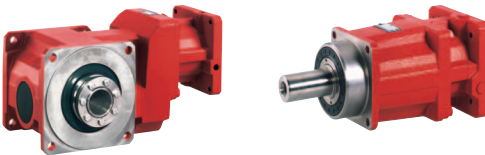



9.5 Variants and options of BS.F, PS.F and PS.C gear units

Helical-bevel gear units BS.F

The following table shows possible BS.F helical-bevel gear unit variants:

Designation	
BSF..	Solid shaft without key
BSKF..	Solid shaft with key
BSBF..	Solid shaft with flange block shaft
BSHF..	Hollow shaft with shrink disk
BSAF..	Hollow shaft with keyway
BSKF..B	Solid shaft with key and foot/front-end mounting
BSBF..B	Solid shaft with flange block shaft and foot/front-end mounting
BSHF..B	Hollow shaft with shrink disk and foot/front-end mounting
BSAF..B	Hollow shaft with keyway and foot/front-end mounting

PS.F planetary gear units

The following table shows possible PS.F planetary gear unit variants:

Designation	
PSF..	Solid shaft without key
PSKF..	Solid shaft with key
PSBF..	Solid shaft with flange block shaft

PS.C planetary gear units

The following table shows possible PS.C planetary gear unit variants:

Designation	
PSC..	Solid shaft without key
PSKC..	B5 output flange, solid shaft with key
PSCZ..	B14 output flange, solid shaft
PSKCZ..	B14 output flange, solid shaft with key

Options

The following table shows possible options for BS.F gear units:

Designation	
..R	Reduced backlash
..T	Torque arm
..I	Hollow shaft and shrink disk at the output end

The following table shows possible options for PS.F gear units:

Designation	
..R	Reduced backlash
..M	Minimized backlash



9.6 Nameplate / type designation

Nameplate of a PS.C.. planetary gear unit with ECH.. adapter

The following figure shows an example of a nameplate:

SEW-EURODRIVE						i	10
76684 Östringen/Germany						kg	5,9
PSC321 ECH03/13/11						IP	65
01.3215264201.0001.08						IM	M0
na pk	r/min	650	ne pk	r/min	6500		
Ma pk	Nm	81					
Made in Germany							
CLP PG 220 Synth.Öl / 0,091L 0117 899 7							

1872039435

i		Gear unit reduction ratio
IM		Mounting position
IP		Degree of protection
n_{epk}	[rpm]	Maximum permitted input speed
n_{apk}	[rpm]	Maximum permitted output speed
M_{apk}	[Nm]	Maximum permitted output torque

Type designation of PS.F.. planetary gear units with EPH.. adapter



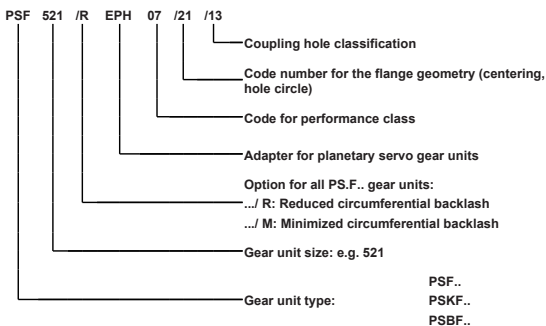





The following diagram shows an example of a type designation:





9.7 Components on the input side

The following table provides an overview of components on the output side:

IEC or NEMA adapter AM		<ul style="list-style-type: none"> • For mounting motors according to IEC standard or NEMA • IEC motors: Adapter for sizes 63 – 280 • NEMA motors: Adapter for sizes 56 – 365. • Positive torque transmission via fail-safe claw coupling.
AR adapter with torque limiting coupling		<ul style="list-style-type: none"> • Non-positive torque transmission • Adjustable slip torque • Slipping clutch in the event of overload to prevent damage
AT adapter with hydraulic centrifugal coupling		<ul style="list-style-type: none"> • Adapter for high-inertia starting systems • Protection against overload during the startup phase • Soft starting • Touch-safe installation • SEW motor sizes 71 – 180 can be mounted. For motor sizes 200 to 280, helical-bevel gear units are available with hydraulic centrifugal coupling on a swing base. • Preferred speeds: 1400 rpm and 2800 rpm
Adapter with hydraulic centrifugal coupling and disk brake option AT../BM(G)		<ul style="list-style-type: none"> • Adapter for defined deceleration. • The DC-operated electromagnetic disk brake meets the safety requirements of braking in the event of a power failure. • Various braking torques are possible. • Available with DC or AC voltage connection • Optional manual brake release
Adapter with hydraulic centrifugal coupling on a swing base		<ul style="list-style-type: none"> • For motors from size 200 • Optional brake
AD input shaft assembly		<ul style="list-style-type: none"> • For drive via exposed shaft extension • Input shafts have metric dimensions according to IEC standard. • The end of the input shaft has a center bore • High overhung loads due to solid output shaft bearings
Input cover with motor mounting platform AD../P		<ul style="list-style-type: none"> • Space-saving installation due to adjustable motor mounting platform. • Arranged parallel to the input shaft • With thread bores for IEC standard motors
AQ adapter for servo-motors		<ul style="list-style-type: none"> • For mounting servomotors to R, F, K, S and W gear units • Torque is transmitted via claw coupling



10 Industrial Gear Units

10.1 X.. series

Description

Robust and universal gear unit series which can be optimally adjusted to the task due to finely stepped torque ratings. The universal modular system concept sets new standards with respect to availability and offers a broad range of application options, e.g. for conveyor systems, ball mills and agitators. Application gear units, such as for bucket conveyors, complete the range.

Gear unit type

SEW-EURODRIVE distinguishes between 3 gear unit types:

- **X.F..:** Helical gear units with parallel shafts

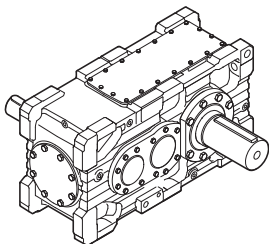

- **X.K..:** Bevel-helical gear units with right-angle shaft arrangement

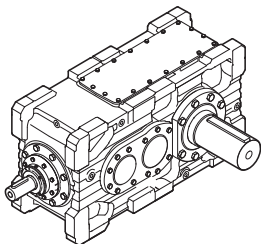

- **X.T..:** Bevel-helical gear units with right-angle shaft arrangement

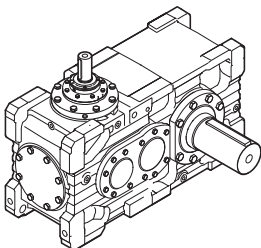



Nameplate

The following figure shows a nameplate:

○ SEW-EURODRIVE		Bruchsal / Germany		○	
Type	X3KS190/B				
Nr. 1	01.1101687801.0001.10 / 66.1234567812				
	norm.	min.	max.	i	1 :
PK1 [kW]	180	36	180	FS	40.61
MK2 [Nm]	43300	43300	43300	FR1 [N]	1,5
n1 [1/min]	1480	296	1480	FR2 [N]	0
n2 [1/min]	37.9	7.6	37.9	FA1 [N]	0
Operation instruction have to be observed!					FA2 [N]
Made in Germany					0
					Mass [kg]
					1340
Qty of greasing points	2	Fans	0	IMM1-F1	
	CLP HC460 - Synthetic Oil - 79 ltr.			Year	2010
○					

9007199673386507

Type	Type designation
No. 1	Manufacturing number
P_{K1}	Operating power on the input shaft (HSS)
M_{K2}	Gear unit output torque
n₁	Input speed (HSS)
n₂	Output speed (LSS)
norm.	Standard operating point
min.	Operating point at minimum speed
max	Operating point at maximum speed
i	Exact gear unit reduction ratio
F_S	Service factor
F_{R1}	Actual overhung load acting on the input shaft
F_{R2}	Actual overhung load acting on the output shaft
F_{A1}	Actual axial load acting on the input shaft
F_{A2}	Actual axial load acting on the output shaft
Mass	Weight of the gear unit
Number of greasing points	Number of regreasing points
Fans	Number of installed fans
	Oil grade and viscosity class/oil quantity
Year	Year of manufacture
IM	Mounting position and mounting surface



Type designations

Example: Gear unit

The following diagram shows a type designation:

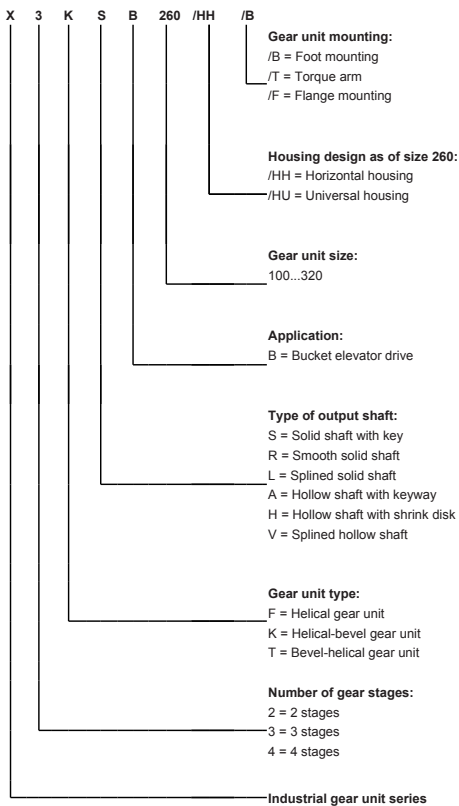



Example: Oil supply systems

The gear unit can be equipped with an oil supply system for cooling and lubrication purposes. The type designation is set up as follows:

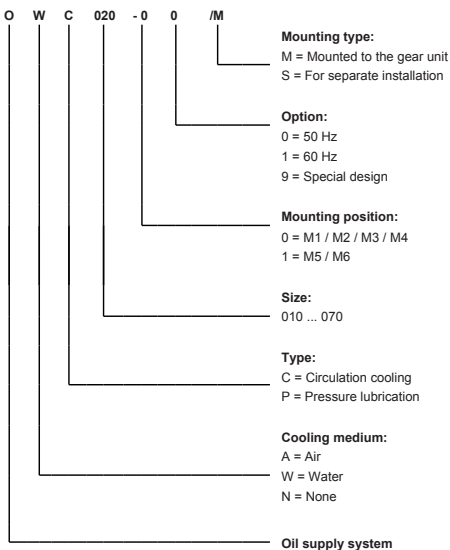

Example: Flange couplings

The type designation of a coupling half is set up as follows:

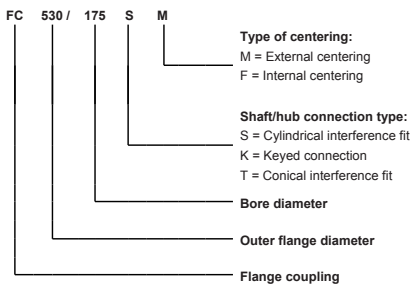



Abbreviations for optional accessories

The table shows the abbreviations used and what they mean.

Abbreviation	Meaning
/BF	Base frame
/BS	Backstop
/BSL	Torque-limited backstop
/CCV	Water cooling cover
/CCT	Water-cooling cartridge
/F	Mounting flange
/FC	Flange coupling
/FAN	Fan
/FAN-ADV	Fan version Advanced
/ET	Oil expansion tank
/HH	Horizontal housing
/HU	Universal housing
/HSST	Through-going input shaft
/LSST	Through-going output shaft
/MA	Motor adapter
/SB	Swing base
/SEP	Shaft end pump
/T	Torque arm
/OAC	Circulation cooling oil-air cooler with motor pump
/OWC	Circulation cooling oil-water cooler with motor pump
/OAP	Circulation cooling oil-air cooler with pressure lubrication and motor pump
/OWP	Circulation cooling oil-water cooler with pressure lubrication and motor pump
/ONP	Pressure lubrication and motor pump
/OD	Oil dipstick
/ODV	Oil drain valve
/OLG	Oil level glass
/OH	Oil heater
/VBD	V-belt drives

All options are part of the type designation except for mounting flange, torque arm, horizontal and universal housing.



10.2 MC.. Series

Description

MC series industrial gear units are particularly compact helical and helical-bevel gear units. The 7 sizes available in the MC series cover the 6 to 65 kNm torque range. Their parallel shaft design offers plenty of flexibility in system design and requires remarkably little space. Application range for MC gear units: e.g. in materials handling, transporting heavy loads, mixing, crane drives and shredders. A version based on this series, with extended bearing distance and reinforced output shaft, is also available.

Gear unit type

SEW-EURODRIVE distinguishes between 2 gear unit types:

- **MC.P.:** Helical gear units with parallel shafts

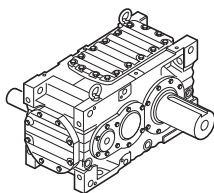

3546970251

- **MC.R.:** Bevel-helical gear units with right-angle shaft arrangement

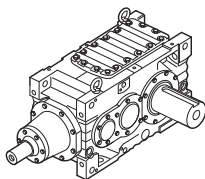

3546972427



Nameplate

The following figure shows a nameplate:

○ SEW-EURODRIVE Bruchsal / Germany ○	
Type	MC3RLSF02
Nr. 1	03 30764647
Nr. 2	K3463
	norm. min. max. i 1 :
PK1 [kW]	16.5 16.5 16.5 FS 3.64
MK2 [kNm]	2.04 2.04 2.04 FR1 [kN] 0
n1 [1/min]	1500 1500 1500 FR2 [kN] 0
n2 [1/min]	73.8 73.8 73.8 FA1 [kN] 0
Operation instructions have to be observed!	
Made by	SEW-Finland Mass [kg] 219
Qty of greasing points	2 Fans 0
Lubricant	Mineral Oil ISO VG 460 EPPAO-7 tr. Year 2003
○	

Type	Type designation
Nr. 1	Serial number 1: EURODRIVER order number (e.g. SAP order number)
Nr. 2	Serial number 2: (manufacturing number of the plant / assembly plant)
P _{K1}	Operating power on the input shaft @ n ₁ norm. Operating power on the output shaft @ n ₁ min. Operating power on the output shaft @ n ₁ max.
M _{K2}	Operating torque on LSS @ n ₁ norm. operating torque on LSS @ n ₁ min. Operating torque on LSS @ n ₁ max.
n ₁	Input speed (HSS) Minimum present input speed (HSS) Maximum present input speed (HSS)
n ₂	Output speed (LSS) Minimum present output speed (LSS) Maximum present output speed (LSS)
Made by	Gear unit assembly/production site
norm.	Normal operating point
min.	Minimum operating point
max	Maximum operating point
i	Exact gear unit reduction ratio
F _S	Service factor
F _{R1}	Radial force acting on HSS
F _{R2}	Radial force acting on LSS
F _{A1}	Axial force acting on HSS
F _{A2}	Axial force acting on LSS
Mass	Gear unit weight
Qty of greasing points:	Number of regreasing points (e.g. when using regreaseable labyrinth seals or Drywell sealing system)
Fans	Number of fans installed on the gear unit
Lubricant	Oil grade and viscosity class/oil quantity
Year	Year of manufacture
IM	Design: Housing positions and mounting surface
TU	Permitted ambient temperature



Type designation

The following diagram shows a type designation:

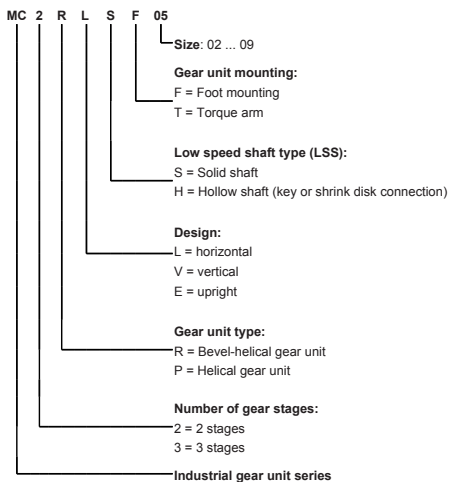

10.3 P002 – P082 series

Description

Planetary gearmotors are a combination of

- P.. planetary gear unit output stage
- Primary gear unit RF.. or KF..
- Mount-on components: Motor, coupling, adapter and backstop

There are 9 sizes of planetary gear units with rated torques from 24830 Nm to 359400 Nm.

The load distribution to several planet wheels results in a significantly higher power density and consequently in smaller dimensions compared to helical and bevel-helical gear units.

The following figure shows a sample combination of a planetary gear unit, a primary gear unit and a motor.

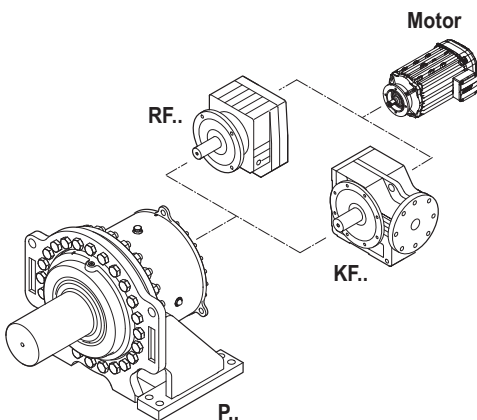

3543065611

- P.. Planetary gear unit
RF.. Helical gear unit (flange-mounted)
KF.. Helical-bevel gear unit (flange-mounted)



Nameplate and type designation

Planetary gear unit

The following figure shows a nameplate:

○ SEW-EURODRIVE Bruchsal / Germany ○	
Type	PF042 KF97 DRS132 ML4 / TF
Nr. 1	01.1101687801.0001.10 / 12345678
	norm. min. max. i 1 : 1880
PK1 [kW]	6.6 1.3 6.6 FS 1.3
MK2 [Nm]	77000 77000 77000 FR1 [N] 0
n1 [1/min]	1430 285 1430 FR2 [N] 0
n2 [1/min]	0.77 0.15 0.77 FA1 [N] 0
Operation instruction have to be observed! FA2 [N] 50000	
Made in Germany	Mass [kg] 840
Qty of greasing points	0 Fans 0
	CLPHC VG220 synth. Oil - 29 ltr. Year 2010
○ <input type="text"/> ○	

3319008779

Type	Type designation
Nr. 1	Manufacturing number
P_{K1}	Operating power on the input shaft (HSS)
M_{K2}	Gear unit output torque
n₁	Input speed (HSS)
n₂	Output speed (LSS)
norm.	Normal operating point
min.	Operating point at minimum speed
max.	Operating point at maximum speed
i	Exact gear unit reduction ratio
F_S	Service factor
F_{R1}	Actual overhung load acting on the input shaft
F_{R2}	Actual overhung load acting on the output shaft
F_{A1}	Actual axial load acting on the input shaft
F_{A2}	Actual axial load acting on the output shaft
Mass	Weight of the gear unit
Qty of greasing points	Number of regreasing points
Fans	Number of installed fans
	Oil grade and viscosity class/oil quantity
Year	Year of manufacture
IM	Mounting position and mounting surface



The following diagram shows a type designation:

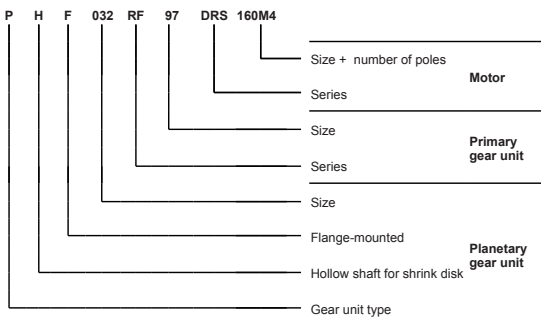



Primary gear unit

The following figure shows a nameplate:

SEW-EURODRIVE			
76646 Bruchsal / Germany		IM M3B	
K57 AQH140/1			
01.1234567890.0001.08			
○		i	19,34 ○
na pk r/min	232	ne pk r/min	4500
		Ma pk Nm	665
			kg 32
		Made in Germany	
		0641 543 1	
CLP HC 220 Synth.Öl / 2,4L			

210927627

- f_b = Service factor
- $F_{Ra\ max}$ = Maximum overhung load on the output side
- $F_{Re\ max}$ = Maximum overhung load on the input side (with input shaft assembly AD)
- i = Gear unit reduction ratio
- IM** = Mounting position
- IP..** = Degree of protection
- $n_{e\ max}$ = Maximum input speed
- n_a = Output speed
- $M_{e\ max}$ = Maximum input torque
- M_a = Output torque
- M_R = Overload torque when using an AR adapter
- M_{RS} = Locking torque of the backstop

The following diagram shows a type designation:

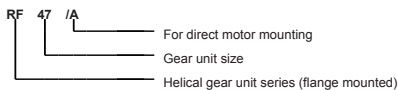

Primary gear unit with motor

The following figure shows a nameplate:

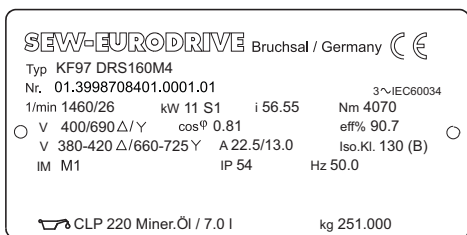

1419791115

Type	Type designation
Nr.	Serial number of primary gearmotor
i	Gear ratio
rpm	Input/output speed
Nm	Output torque
kW	Input power of the gear unit
S1	Duty cycle
cos φ	Power factor of the motor
V	Supply voltage in delta/star connection
A	Rated motor current in delta/star connection
Hz	Line frequency
IM	Mounting position
kg	Weight of the primary gearmotor
IP	Degree of protection of the motor
Brake V	Brake connection voltage
Nm	Braking torque
	Oil grade and viscosity class/oil quantity

The following diagram shows a type designation:

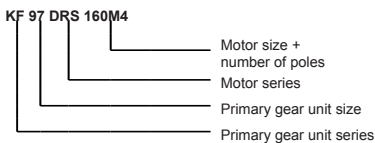

17040817 / 0211

DRIVE ACADEMY®

P.O. Box 3023 · 76642 Bruchsal/Germany
Phone +49 7251 75-0 · Fax +49 7251 75-1970

→ www.driveacademy.sew-eurodrive.de

