

e-chain®  
igus.eu. e-chains® and -systems. 06.2013. plastics for longer life®



Systems®

# fast!!!

## Improve technology and reduce costs

For years the igus® motto has been "plastics for longer life®". By this we mean the production of innovative plastic products which reduce maintenance work, achieve technical improvements, at the same time as reducing costs and increasing service life, everything delivered immediately from stock.



### Available from stock.

**Delivery time\* in 24h or today!**

\*Delivery time means time until shipping of goods (after technical release)



### No minimum order value!

**No surcharges!**

You can find our prices online at [www.igus.eu](http://www.igus.eu)



### Guarantee

Beyond the legal warranty we also vouch for wear and tear. With a warranty certificate!



### "8 to 8 plus Saturday" service

Monday till Friday 8:00 am to 8:00 pm and Saturday from 8:00 am to 12:00 pm



### Hotline

Phone +49-2203-9649-800

Fax +49-2203-9649-222



### Onlineshop [www.igus.eu](http://www.igus.eu)

Product finder, configurator, online catalogs, CAD modules and many more. Order around-the-clock!



### Do you have any questions?

For questions and more information call us or use our online productfinder at [www.igus.eu](http://www.igus.eu)



## Design and calculation tools, applications, diagrams

Designing with igus®, igus® readychain®

from page  
**82**



## Low-priced, easy to fill e-chains®

easy chain®, System E1, snapchain

from page  
**138**



## Zip-open, easy to fill e-chains® and e-tubes

zipper e-chains® and e-tubes

from page  
**174**



## Allrounder e-chains® and e-tubes, snap-open, micro, mini, medium sizes

E2 micro, mini, E2/000 medium

from page  
**196**



## Dirt- and debris protection, snap-open e-tubes

E2 e-tubes: Series R, Series R100 and Series RX

from page  
**298**

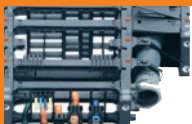

## Universal E4 modular kit, e-chains® and e-tubes for all applications

System E4 - Series E4.1, E4.1 light and E4/light

from page  
**362**



## Cleanroom e-chains® and e-tubes, low noise, low vibration

System T3, E3, E6 and E6.1

from page  
**476**



## Multi-axis e-chains® for robotic or 3D movements

triflex® R, triflex®, twisterchain®, twisterband

from page  
**544**



## Strain relief... clamps, tie-wrap plates, clips, etc.

chainfix strain relief

from page  
**630**



## Guide troughs for long travel applications

Aluminum SuperTroughs, steel guide troughs, support trays

from page  
**656**



## Special solutions for long travel applications without guide troughs

System P4, rol e-chain®, autoglide, guidelok, fiizz®

from page  
**724**



## Appendix

Faxforms, addresses igus®

from page  
**762**

# plastics for longer life<sup>®</sup> - make your machines more durable with plastics

Less maintenance, lower costs, longer life cycles, ex-stock availability - these key principles apply to all igus<sup>®</sup> products, systems and services. Tried and tested for durability, low friction properties and stability. igus<sup>®</sup> plastics are the technological core of the igus<sup>®</sup> range. This catalog lists more than 90,000 products available ex stock. We are looking forward to your phone call or e-mail.



igus<sup>®</sup> climate chamber - e-chain<sup>®</sup> and  
chainflex<sup>®</sup> cables test runs possible at +60°C to -40°C

## Improve technology and reduce costs

For years the igus® motto has been "plastics for longer life®". We stand for our Philosophy, which is represented in our products. They reduce maintenance work, achieve technical improvements, reduce costs as well as they increase service life and they can be immediately delivered from stock.



### Available from stock.

**Delivery time\* in 24h or today!**

\*Delivery time means time until shipping of goods (after technical release)



### No minimum order value!

**No surcharges!**

You can find our prices online at [www.igus.eu](http://www.igus.eu)



### Guarantee

Beyond the legal warranty we also vouch for wear and tear. With a warranty certificate!



### "8 to 8 plus Saturday" service

Monday till Friday 8:00 am to 8:00 pm and Saturday from 8:00 am to 12:00 pm



### Hotline

Phone +49-2203-9649-800

Fax +49-2203-9649-222



### Onlineshop [www.igus.eu](http://www.igus.eu)

Product finder, configurator, online catalogs, CAD modules and many more. Order around-the-clock!



### Do you have any questions?

For questions and more information call us or use our online productfinder at [www.igus.eu](http://www.igus.eu)



igus® headquarters in Cologne - development, production and marketing from a single location

Orders can be placed until 8:00 pm local time.

Phone +49 2203 9649-800

"Emergency-Service" around the clock.

90.000 products from stock.

No minimum order quantities, no surcharges.

igus® is certified in accordance with

DIN EN ISO 9001:2008 and ISO/TS 16949:2009

in the field of energy chains® with cables and harnessing, as well as plastic plain bearings.

# 24h/90.000

# DIN EN ISO 9001:2008

# ISO/TS 16949:2009

# thee-chain igus® e-chains® are lifelines to automated systems

e-chains® are the umbilical of modern machines. They are constantly moving and supply power, data and energy. igus® has been developing, producing and testing polymer e-chains® since 1971. Our expert knowledge is being refined continuously with the help of our customers to constantly improve our product range.

## Universal applications for igus® e-chains®

- Multitude of possibilities in terms of movement and length
- To carry sensitive bus, data cables and fibre optic cables and energy sources such as electricity, gas, air and liquids
- To accommodate very high dynamic loads and stringent service life requirements
- Handle very different environments and climates
- Space-saving installation
- High speeds and accelerations can be achieved
- Modular systems allow quick assembly and retrofit

## Save time and money when purchasing and utilising e-chains®!

- Innovative products that can be assembled quickly
- Rapid delivery time - saves you storage costs
- Large range of products - find the right solution immediately
- System quotes, including made-to-measure production and "turnkey" assembly
- Rapid system design and support with an ever-growing close-knit network of local sales engineers worldwide

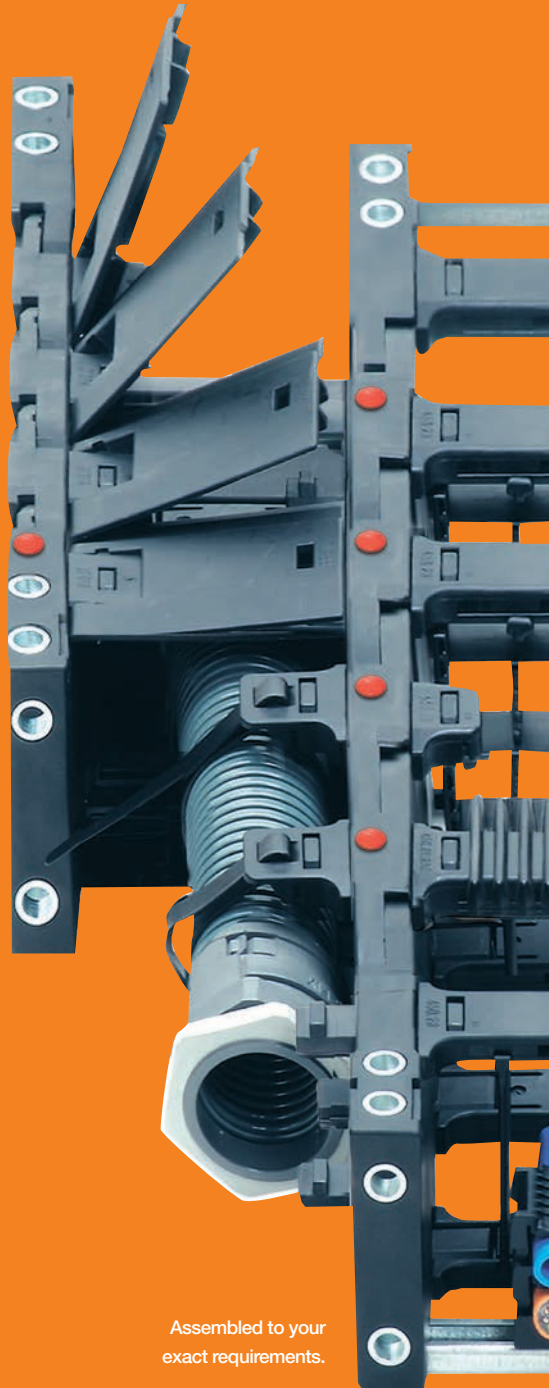

Find a video online  
[www.igus.de/automated](http://www.igus.de/automated)



The award-winning igus® e-chainsystems® are certified and tested

Assembled to your exact requirements.

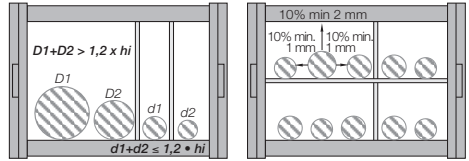
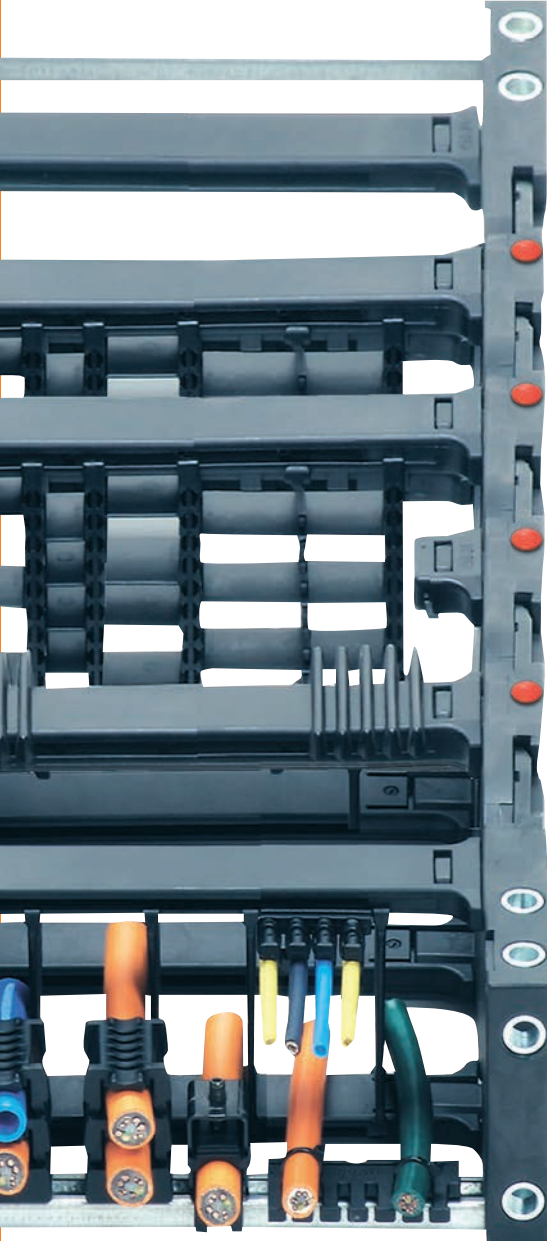

igus® interior separation systems significantly lengthens the life cycle of cables and enable neat layout of e-chains®.

Filling guidelines ► from page 115

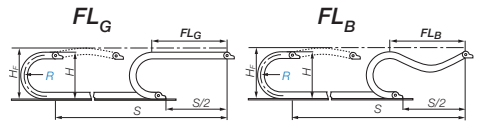

Large unsupported lengths with igus® e-chains®. Notes, calculations and load diagrams are provided ► from page 92

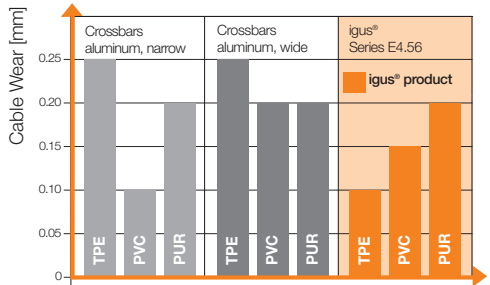

Optimum service life for cables -

Reduce cable wear with igus® polymer crossbars

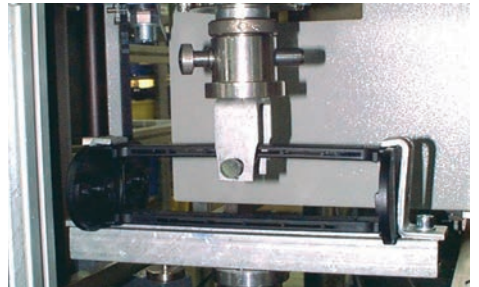

Proven toughness - strength testing in the igus® laboratory

# Matching accessories for your igus® e-chainsystems®

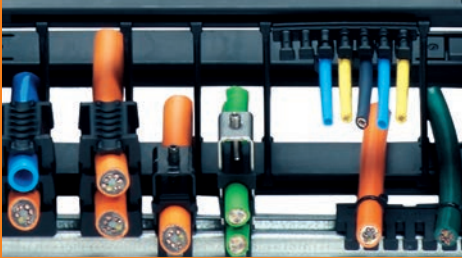

Ranging from reliable strain-relief systems for cables through interior separators for proper division of e-chains® to autoglide crossbars for long travels without guide troughs or special igus® guide troughs for extra-long travels. igus® offers the right solution for every application. The large accessory kit from igus® permits upgrading of your e-chain® to a high-tech solution. Matched specially with igus® e-chains®, igus® accessories have been tried and tested in practical applications for many years now.



Super-aluminum guide trough. The igus® standard aluminum guide trough in two designs - lightning fast assembly ► page 664



Find a video online  
[www.igus.de/SALU\\_Film](http://www.igus.de/SALU_Film)



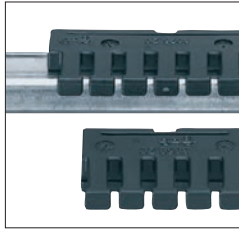

Tiewrap plates, with clip-on connection for the C-profile of a KMA mounting bracket

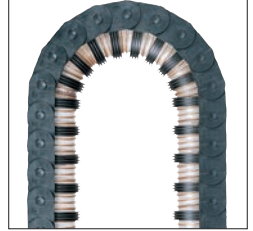

igus® developed extension links for the safe guidance of huge hoses in e-chains®



Special connecting elements with strain-relief for trifix® R (3D-robot) e-chains®

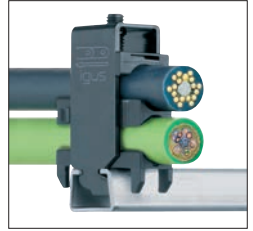

chainfix cable strain-relief systems. Various systems for individual use

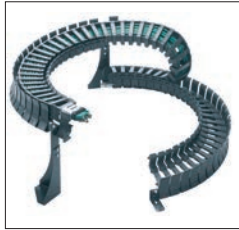

twisterchain® guide trough systems permit e-chain® rotation as far as 540°

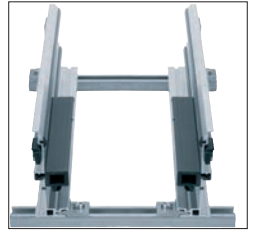

Aluminum SuperTrough - igus® standard guide trough. Very simple, modular assembly

# chainflex<sup>®</sup> lasts. Or your money back.

Your production processes must remain trouble-free, and that means your energy supply systems too. This requires fully reliable operation by all relevant components, including cables. igus<sup>®</sup> was the first company to develop complete e-chainsystems<sup>®</sup>. igus<sup>®</sup> chainflex<sup>®</sup> cables and e-chains<sup>®</sup> are offered together from a single source with a system guarantee depending on the application involved design principles based on knowledge of cables and exhaustive test Series since 1989 prevent machine downtimes in plants all over the world today.

## 7 rules for making a good cable

### 1. Strain-relieved core

Empty space arises at the core of the cable depending on the number and cross-section of the conductors. This core space should be filled to the greatest possible extent with a proper rope (not with the usual fillers or dummy wires made of waste material). This reliably braces the surrounding strands and prevents them from sliding into the middle of the cable.

### 2. Strands

Experience has shown that the strand structure should be as flexible as possible. Although very thin individual wires result in very flexible conductors, these are highly susceptible to damage. Extensive tests have helped to determine which combination of wire diameter, strand pitch and strand direction optimizes bending resistance.

### 3. Core insulation

Insulating materials must be designed so that they do not stick together once inside the cable. Furthermore, the insulation should brace the individual wires of the cable. For this purpose, we use only the best PVC and TPE extruded at high pressure and proven in millions of kilometres of wire forming part of e-chain<sup>®</sup> applications.



Certified No. 141

Conventional "chain suitable" cable (left) and igus® chainflex® - special cable with 7 rules for a good cable (right)

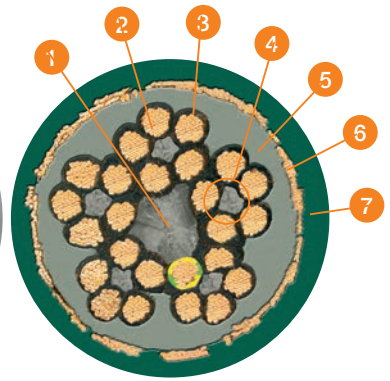

#### 4. Braids

Braids must have an optimized, short pitch around a stable, strain-resistant core. To co-exist properly with the insulating materials, braids must allow movement over a certain range. Starting from a quantity of 12 cores stranding in bundles should be applied.

#### 5. Inner jacket

A gusset-filling, extruded inner jacket should be used instead of low-cost non-woven fabric, filler or tracer. This permits secure longitudinal routing of the braid. It also prevents the braid from loosening and drifting.

#### 6. Shielding

The shield should generally have a taut structure with an optimized angle of twist about an extruded inner jacket. Loose, open structures or, worse yet, purely circumferential windings notably reduce electromagnetic compatibility and can fail easily as a result of wire breakage. A taut shield braid makes the underlying wire braid more resistant to torsional strain.

#### 7. Outer jacket

An external jacket made of ideal materials can meet a wide range of specifications: From UV resistance through low-temperature flexibility and oil resistance to cost-effectiveness. However, all external jackets should have the following in common: Highly resistant to abrasion without sticking and highly flexible while still supportive. In addition, all external jackets should be extruded at high pressure (gusset-filling).

**QuickPin 2.0 - Online connector-cable-configurator ► page 23**

Order separate catalog online

[www.igus.eu/eu/chainflex](http://www.igus.eu/eu/chainflex)

or Phone +49 2203 9649-0

readychain<sup>®</sup> harnessed  
e-chainsystems<sup>®</sup>  
are listed from page 129

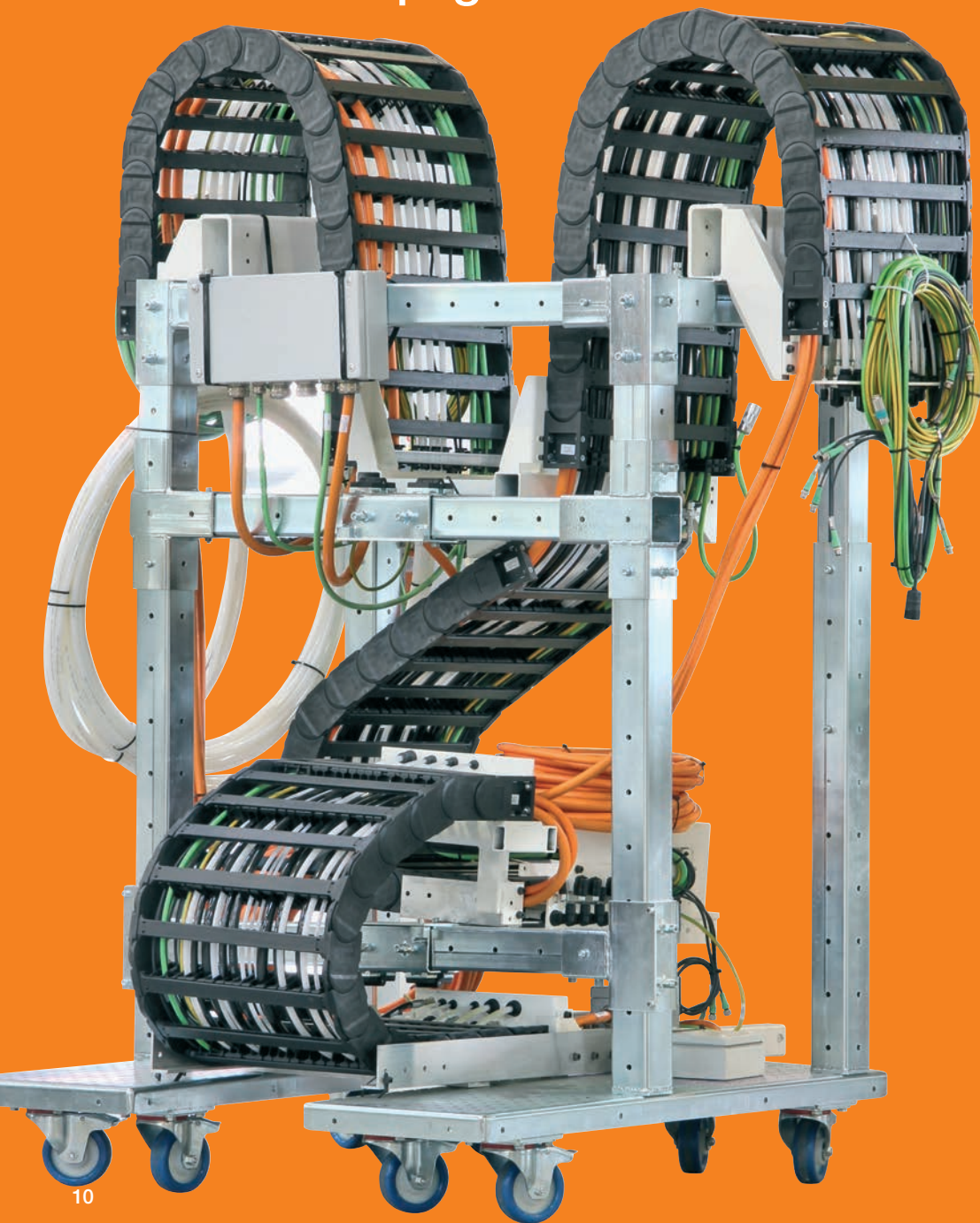

### Eliminate storage costs for cables, e-chains® and plugs

Our short and guaranteed delivery periods enable you to dispense entirely with a storage of ultra-flexible cables, related plugs and add-ons.

### Shorten turnaround times by half

Thanks to sophisticated logistics, igus® is able to supply complete systems within 10 days of the guaranteed deadline to almost any part of the world.

### Flexible response to order fluctuations

With readychains®, you remain prepared for all phases of an economic cycle. Fluctuations in your capacity utilization are absorbed by our product logistics.

### Reduce the number of subcontractors and related orders by 75%

One order, one invoice, one delivery, one partner. You no longer need to procure countless individual components from a host of subcontractors; we know how to acquire the right parts quickly and economically.

### Minimize your machine downtimes

External purchases of numerous individual components not only make your systems more susceptible to malfunction but also make trouble-shooting more difficult. readychains® provide you with standardized systems. Every system is tested at our facility prior to delivery. igus® is certified according to ISO 9001. [www.igus.eu/eu/readychain](http://www.igus.eu/eu/readychain)



Find a video online  
[www.igus.eu/eu/RC\\_movie](http://www.igus.eu/eu/RC_movie)

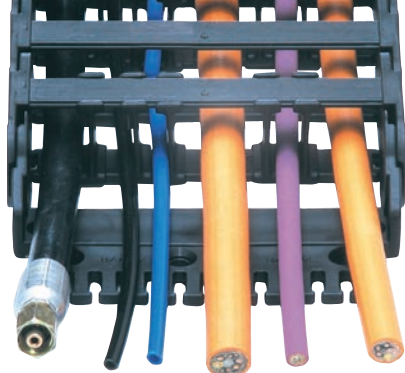

### "Basic" readychain®

Simple, harnessed e-chainsystems® including installed cables without plug connections, labelled and tail-lengths according to your specifications.



Delivery time\*: 3 days

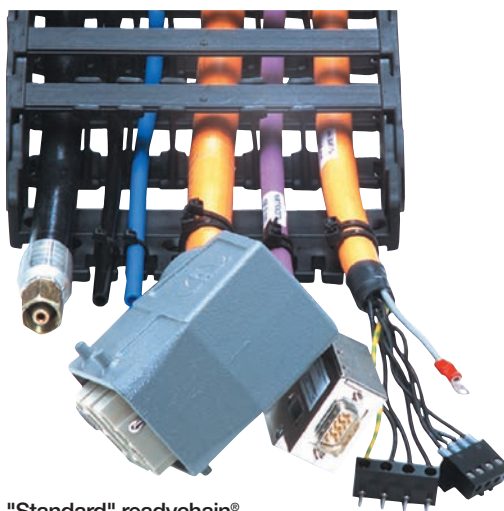

### "Standard" readychain®

Simple, harnessed e-chainsystems® including installed cables with all plug connections, labelled and tail-lengths according to your specifications.



Delivery time\*: 3-5 days

### Figure left: "Premium" readychain®

A harnessed e-chainsystem® with cables of all kinds, as well as plugs, connectors, tail-lengths and components according to your specifications.



Delivery time\*: 10 days

\*Delivery time means time until shipping of goods (after technical release)

# Quality from the igus® laboratory: Tested and proven every day.

Applications involving high cycle counts, speeds and accelerations or demanding environmental conditions require proven systems especially when it comes to e-chains®, cables, polymer slide bearings and linear systems. igus® regularly conducts tests at its own laboratory under realistic conditions. Every year, we conduct more than 15,000 für e-chains®, cables and polymer bearings. These tests focus on push/pull forces, friction values, wear rates, drive forces and abrasion under all possible conditions at diverse speeds. Influential factors like soiling, weathering, cold and impact are examined. Tests are also performed on electric cables and hydraulic and pneumatic hoses. Our laboratory is at your disposal. Should we lack data for your application type, we will gladly conduct tests according to your requirements.



Find a video online  
[www.igus.de/testlab](http://www.igus.de/testlab)



igus® system warranty - Every application is different. igus® warranty certificates can be issued for your application individually. Ask for igus® warranty: "chain, cable, guarantee"



Figure center: Partial view, igus® test-lab: More than 80 tests every day with e-chains® and chainflex®-cables



igus® ESD-tests  
in the production line



Electronic check and archiving  
for every chain production run



Cables are also tested  
for torsion properties

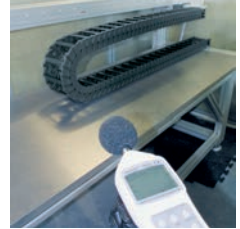

Noise level test inside  
an igus® acoustic cell



igus® dynamic  
bending test



Long term wear test  
of P4 rol e-chains®

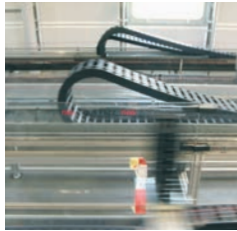

Push Pull forces speed up to 10  
m/s, acceleration up to 200 m/s<sup>2</sup>  
are tested by igus®



Long travel test field: 125 m  
travel length, speed 300 m/min



All products are tested and available from a single source.

Examples of test certificates and quality seals for igus® products

# Quick and reliable. igus® delivery service.



## 8 to 8 plus Saturday service

Over 90,000 products ex-stock! Order 0.1 m of chainflex® cable, just one e-chain® link or two bearings without surcharges. Invoices and acknowledgements available by post, fax or e-mail. There are 2,100 employees in Germany and 30 international subsidiaries and offices to guarantee a rapid delivery worldwide.

- Delivery and consultation daily from 8 am to 8 pm, Saturday from 8 am to 12 pm
- No minimum order values
- No surcharges
- Order tracking on the Internet right up to the point of delivery
- Simple returns procedure

## i-net customer information system

At: [www.igus.eu](http://www.igus.eu) track your orders in real time with igus® i-net. Just request a password, log into i-net and track your jobstatus via a webcam. igus® i-net shipment tracking permits a monitoring of deliveries from igus® outlet right up to your doorstep.

- Detailed order data including an overview of target and actual deadlines
- Order confirmation via post, fax or e-mail as required
- Track your orders via webcam

## igus® delivery service -

**No minimum order quantities, no surcharges.**

[www.igus.eu/eu/deliveryservice](http://www.igus.eu/eu/deliveryservice)

The screenshot shows the 'i-net' interface for tracking orders. The main content area is titled 'Look for your orders' and contains the following fields and options:

- igus order number: [input field]
- Start date: 14.09.2009 (04.mh.jyyy)
- End date: 28.09.2009 (04.mh.jyyy)
- Ignore time period:  No  Yes
- Kind of order:  open  finished  both
- Product group:  energy chain systems  bearing
- Your energy chain systems customer-no.: 2801800
- Your bearings customer-no.: 3560700
- [Query button]

The right sidebar contains a navigation menu with links such as 'igus® Kontakt', 'Über igus®', 'Lieferscheine', 'Presse', 'Kontakt', and 'Einkauf'. It also includes a note about delivery times: 'Über 80.000 Produkte ab Lager! Lieferung und Beratung täglich von 8-20 Uhr und samstags von 8-12 Uhr!'.

Request order tracking here:  
[www.igus.eu/eu/i-net](http://www.igus.eu/eu/i-net)



Available from stock.

Delivery time\*  
in 24h or today!

Delivery time\*  
24-48h

Delivery time\*  
3-5 work days

Delivery time\*  
10 work days

\*Delivery time means time until shipping of goods (after technical release)

### Individual components

*For example:*  
One e-chain® link,  
6 m of e-chain®,  
3 strain-relief elements



### Customized e-chainsystems®

*For example:*  
11.46 m of e-chains®  
with interior separators,  
mounting brackets and strain  
relief elements  
according to your  
specifications.  
Additional with loose  
accessories as  
chainflex®-cables,  
guiding troughs,  
mounting brackets,  
strain reliefs and  
assembly parts

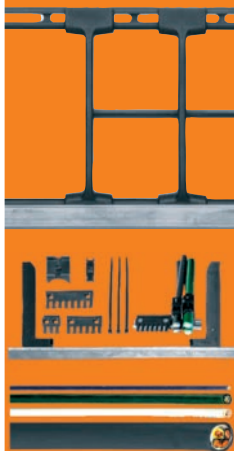

### Simple pre-fabricated systems

*For example:*  
"Basic"  
readychain®:  
Simple customized  
e-chainsystems®  
including installed  
cables without plug  
connections, labeled  
and tail-lengths  
according to your  
specifications



### Complex pre-fabricated systems

*For example:*  
Premium  
readychain®:  
Complex customized  
e-chainsystem®  
including cables as  
well as plug  
connections, mounting  
brackets, tail-lengths  
and components  
according to your  
specifications.



# The igus® story since 1964 until today

## Innovation with plastics

The igus® story begins on October 15th, 1964 with Günter Blase in a double garage in Cologne-Mülheim. In its first 20 years, igus® operated as a supplier of intricate technical plastic components. In 1983, son Frank Blase started to concentrate on full products like e-chainsystems® and Polymer Bearings and established a separate marketing department. Between 1985 and today, igus® expanded from 40 to over 2,150 staff members distributed all over the world. igus® will continue to invest in expansion in the coming years. Modern materials have opened up further opportunities for innovative products.



igus® Sales & Marketing, from left.: Tobias Vogel, Head of Sales & marketing Polymer Bearings, Harald Nehring, authorized signatory, e-chainsystems® & chainflex®, Gerhard Baus, authorized signatory Polymer Bearings, Michael Blaß, Head of Sales & marketing e-chainsystems®, Frank Blase, CEO.



Today: Automated plastic production



Today: Large tool development and production facility

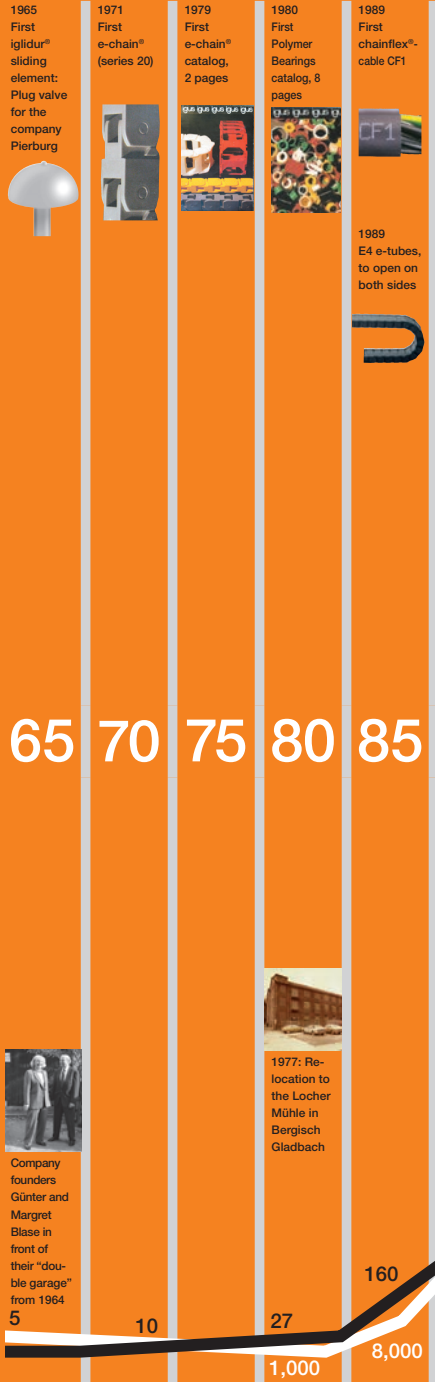

1991  
xigus 1.0  
electronic  
catalog



1993  
intro-  
duction of  
drylin® R



1994  
intro-  
duction of  
igubal®



90



1994: Relo-  
cation to the  
new igus®  
factory in  
Cologne

1995  
readychain®,  
with the slo-  
gan "Chain-  
Cable  
Guarantee®"



1997  
drylin® T



95

2001  
System E6  
e-chains®



2001  
drylin® N



00

2003  
triflex® R



2003  
drylin® W



05

2005  
iglidur®-  
PRT sle-  
wing ring  
bearings



2006  
levichain



2006  
System P4  
rol e-chain®



06

2007  
System  
E4.1  
e-chain®



2007  
drylin®  
ZLW



07

2008  
E4.350 –  
largest  
polymer  
e-chain®



2008  
xiros®  
polymer ball  
bearings



08

2009  
E4.1 – new  
interior  
separation  
tool box



2009  
RX – chip-  
proof  
e-tube



2009  
guidelok  
horizontal –  
for long  
travels



2009  
igus®  
roboLink®



2009:  
Extension  
by around  
60% of the  
igus® factory  
in Cologne

1,800

2010  
igus®-  
twisterband:  
turn 7000°



2010  
pikchain®,  
for Pick &  
Place



2010  
E2/000 –  
Chain opener



2010  
drylin® lead  
screw nut  
with Anti-  
Backlash



10

2011  
E4.1 light –  
allround  
e-chains®  
for high  
dynamics



2011  
GLSL-F  
– safe verti-  
cal guide of  
e-chains®



2011  
drylin® E –  
linear axes  
with step-  
per motor



2011  
iglidur® N54 –  
iglidur®  
goes green



11

2012  
alternative  
to cable  
drums:  
e-spool  
modular kit



2012  
flip open  
chain links  
at triflex® R



2012  
xiros®  
polymer  
ball bearing,  
double row



2012  
drylin® low  
profile axis  
22x28 mm



12

90,000

2,000



2012:  
2nd exten-  
sion of the  
igus® factory  
in Cologne

staff  
products with  
variants

# The flexible igus®-factory



The environment at igus® is fully open - anyone can contact anyone else directly, everyone works at identical desks, has the same work equipment, the same choice of meals at the cafeteria and the same bathroom facilities.

## Investments in better technology and faster delivery times

Catalog items have to be on stock, to mount the modules according to customer requests within hours and shipped. igus® send out from stock in 24 hours or at the same day. We deliver from batch size one and have no minimum order value. igus® are continuing their growth trend and is focusing more than ever on sophisticated yet simpler solutions for all innovations and investments. Nine facilities worldwide were expanded 2012 by between 50% and 250% last year, the factory in Cologne already expanded by 60% in 2009 and is being expanded by more 10,000 m<sup>2</sup> since 2012, and innovation speed stepped up to 134 product innovations (2013). New capacities are being created particularly in the readychain® factory, which is already designed to produce about 50,000 pre-assembled cables per month.



Find a video online  
[www.igus.de/igus\\_Film](http://www.igus.de/igus_Film)

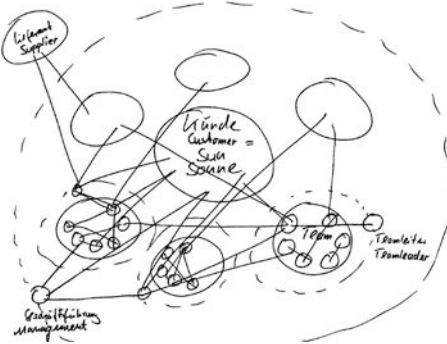

For us, customers have the same significance as the sun to life on earth. The sun gives light, warmth and energy - our customers give us ideas, work and money.

Figure right: The extension by around 60 percent to our lean igus® factory in Cologne is now finished and been put into operation. We supply 90,000 products from stock in 24 hours or on the same day, from a quantity of one and without minimum quantity surcharges.



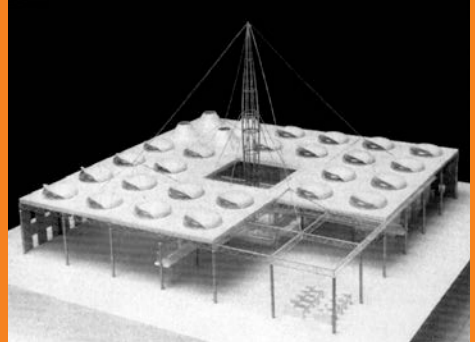
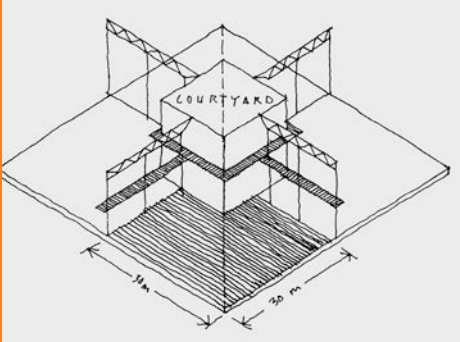

### Excerpt of architect's briefing...

"In October 1988, igus® acquired a plot sized about 40,000 m<sup>2</sup> in the Porz-Lind district of Cologne. This will be the future site of development, production, sales, administration and planning. As the centre of all activities, this location will serve as the new igus® headquarters. igus® has made preparations for fast growth, fast change and flexible response in all areas...

Offering the necessary facilities and technology, the new "igus® premises" will also be designed to promote staff performance. The interior and exterior will be designed to reflect the enterprise's products and key philosophy: innovation - service - reliability, the customer being comparable to a solar system's centre orbited by all igus® staff and igus® entities dedicated toward solving the customer's problems."



# QuickLink - igus® e-chains® on the internet!

igus® plastics for longer life®

Home > E-ChainSystems® > Product overview > E2/000 medium E-Chains® > Series 2400

**Series 2400**

- ✓ Delivery 24 - 48 hours
- ✓ Delivery 2-5 working days
- ✓ Delivery time on request, normally 2 - 6 weeks

Here you can configure your E-ChainSystem® individually. All entries and changes are taking over to the part list which is situated at the end of the page.

**Series 2400 - snap open along the inner radius**

1. Double stop dog system for long unsupported length
2. Optimized opening system for quick opening of the clamp in either left or right direction
3. High retention force of clamp
4. Lateral gliding surfaces for side-mounted operation
5. Tested and proven firmly seated mounting bracket
6. Strain relief can be integrated in the mounting bracket
7. Series 2400 and 2450 snap-open in the inner radius
8. Series 2450 - Half-enclosed E-Tube flip-open on both sides at the inner radius
9. Fully enclosed E-Tube Series 2480 flip-open at the inner radius
10. Multifunctional modular interior separation
11. Easy mounting by optimized pins
12. Available also as ESD version
13. Strain relief separator - separator with

Price index: ●○○  
Opening mechanism: ☒

**Personal contact**  
igus® GmbH  
Spicher Str. 1a  
51147 Cologne  
Germany  
» igus® contact  
☎ +49 (0) 2203-9849-0  
» Send e-mail to igus®

» myigus  
» myCatalog

» Application examples  
» 3D-CAD  
» Samples and catalog order  
» E-Chain® Expert call  
» Service life calculation  
» E-Chain® comparison  
» E-Chain® product finder  
» PDF file  
» Ask the product expert

» Designing with igus®

Go online and make use of all advantages at [www.igus.eu](http://www.igus.eu) or every product in this catalog, there is a special QuickLink or direct online pointer to further useful details, data and facts. These include:

- Application videos and pictures
- Assembly instructions
- 3D-CAD files
- DXF data
- Comparisons and selection aids
- Online configuration tools
- Online wizard for calculations of service life
- PDF-data and other formats for download:  
ePlan-Download
- Personal support
- Catalog, CD and sample ordering forms

Example:  
[www.igus.eu/eu/2400](http://www.igus.eu/eu/2400)



Create your complete e-chain® with cables. A complete e-chainsystem® at few mouse clicks

[www.igus.eu/eu/configurator](http://www.igus.eu/eu/configurator)



"Search" -  
**e-chain® product finder**  
 Find the right e-chain® quickly and easily by entering known application data and other parameters.

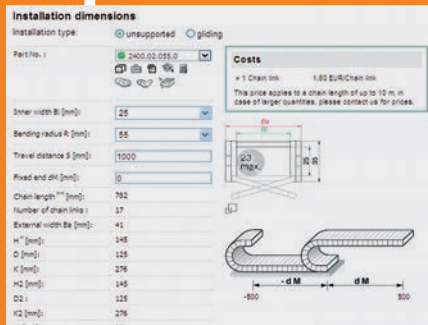

"Calculate chain length"  
**e-chain® length calculation.**  
 Calculate the e-chain® length and see all installation heights

"Configure" e-chain®  
**interior separator configuration**  
 Quickly and easily determine interior separation for the selected e-chain® via Drag & Drop. The configuration can be transferred automatically to your part list.

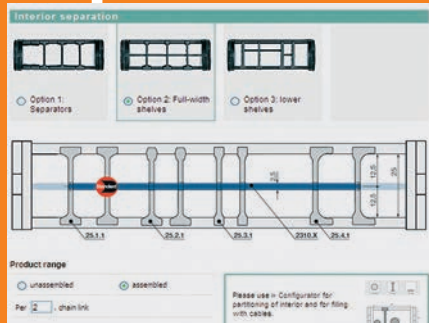

"Generate 3D file"  
**e-chain® CAD library**  
 Download and save CAD data free of charge without having to register. Data on all products are updated and extended on a regular basis - nearly 30 3-D and 2-D formats are available

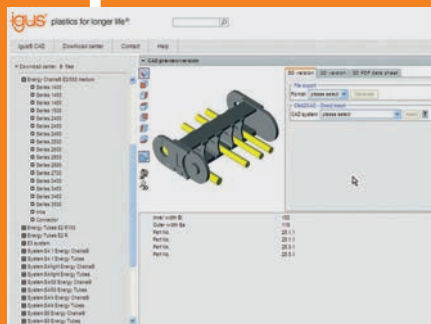

Take a tour [www.igus-CAD.com](http://www.igus-CAD.com)

# igus® online configurator for interior separation-

 [www.igus.eu/eu/quickchain100](http://www.igus.eu/eu/quickchain100)

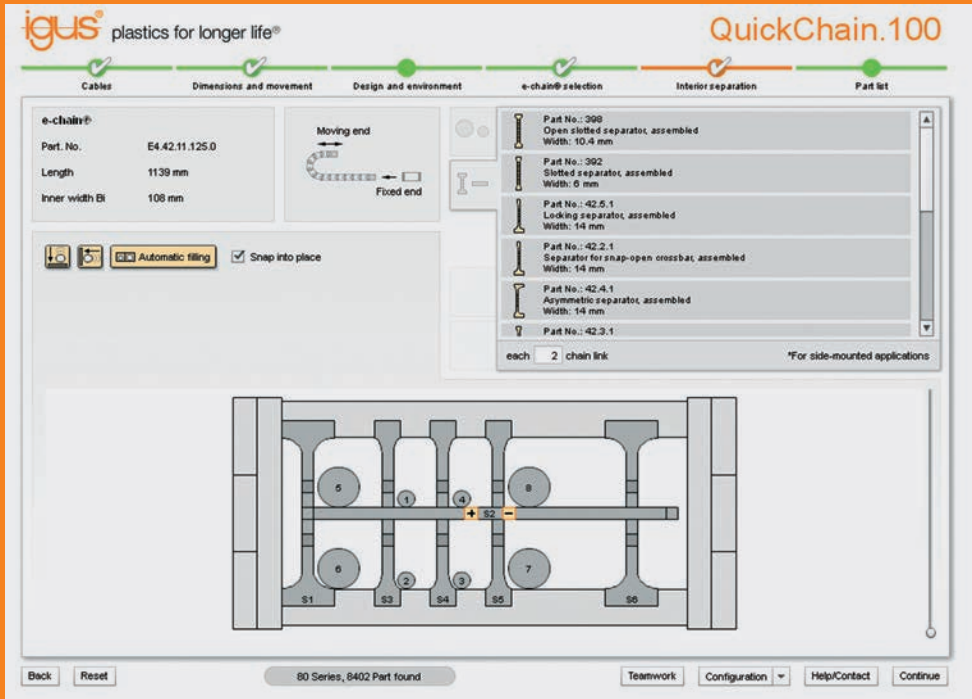

Change the e-chain® and accurately select the correct width directly in the configurator - Cable overview for better handling

igus® online configurator for interior separation!

Quickly and accurately to the correct e-chain® and chainflex® cable combination

With the interior shelving configurator you design the complete filling of an e-chain® easily and quickly and generate a 3D-CAD-file with one click.

- Interior shelving configuration now with logical check of min. bending radius
- No manual calculation and crosscheck of the chainflex® cable diameter and e-chain® cross section necessary
- Now with cable overview for better handling
- Changing of the e-chain® width - now possible also in the inner shelving configurator
- Download e-chain® partlist with interior shelving and cables in Excel format

 [www.igus.eu/eu/quickchain100](http://www.igus.eu/eu/quickchain100)



# Quick & Easy - QuickPin 2.0 - Pin-Out Configurator -

[www.igus.eu/eu/quickpin](http://www.igus.eu/eu/quickpin)



## QuickPin 2.0 - connector-cable configurator, directly integrated in ePLAN P8

In only 3 minutes you choose out of more than 950 chainflex® cables and 3,000 connector components, configure cables online, order directly and generate an ePLAN electric P8 macro

- Create a new configuration directly from ePLAN
- Opening of existing configuration
- Verification of cable configuration
- Acquisition of existing configuration via the download manager for cable macros
- Available in ePLAN P8
- Quick and easy configuration and ordering of chainflex® cables and connectors. Per mouse click and drag & drop
- Circular plug-in connector, squared plug-in connectors, sensor connector M8/M12, D-Sub and free cable ending possible
- Just a click to transfer the configured cable to the shopping basket and inquire, order or memorize for a later order
- Possibility to recall inquired cables from order history for new inquiries
- Online pricing, including copper charge
- Save design work: free of charge delivery of ePLAN electric P8 macro of the configured cable
- Harnessing from one source -100 % tested
- Details of your personal contact person available on the spot
- No installation required
- Many languages available
- Individual connector specification or components by manufacturers part numbers available

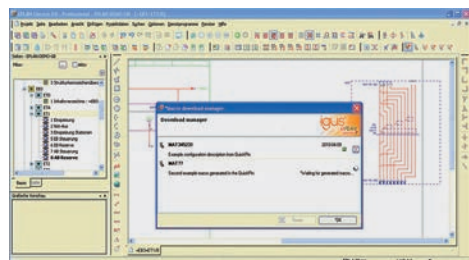
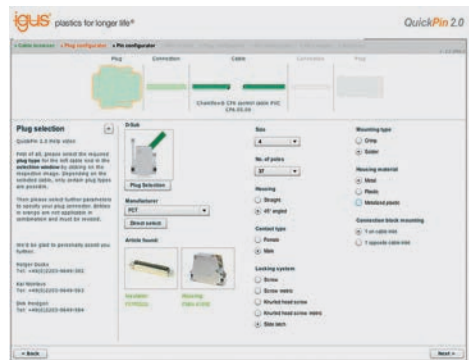

Find a video online  
[www.igus.eu/eu/quickpin-demo](http://www.igus.eu/eu/quickpin-demo)



# CAD online/offline...

## The 3D-CAD system is now also available offline

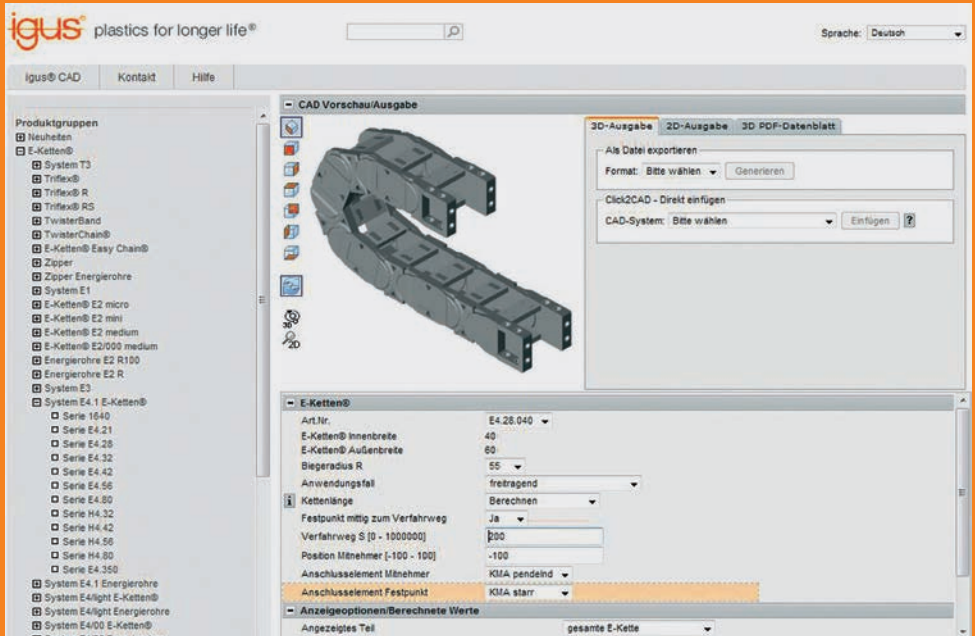

Now available: QuickCAD offline version

### New in this catalog

#### QuickCAD offline version

For all situations with limited internet access QuickCad is now also available as an offline version.

- Generation of 3D CAD models in 32 file formats
- CAD direct insertion driver for faster data transfer to various CAD systems (e.g. AutoCad, Inventor, Solidworks, CATIA, etc.)
- Quick and easy creation of 2D derivatives
- Integrated 2D and 3D CAD viewer
- Generation of 3D PDF datasheets
- 2D and 3D CAD files can be directly integrated in PDF files
- Available in 16 languages
- Runs without installation
- Of course, as ever before, all CAD data are available to you without registration at: [www.igus-cad.com](http://www.igus-cad.com) for quick downloading

[www.igus.eu/eu/quickcad-download](http://www.igus.eu/eu/quickcad-download)

# igus® applications.

## Many example applications with igus® e-chainsystems® from next page

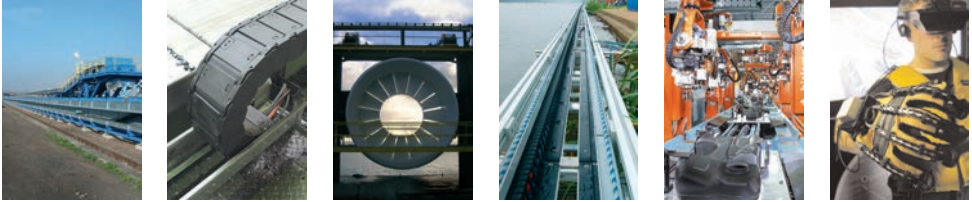

Legal information: The information in this catalog, and the data in the Design section in particular, is based on our current knowledge of the products described. No legally binding assurance in respect of characteristics or suitability for a specifically application can be derived from it. igus® is unable to assume liability of any nature for damage, loss or injury resulting from application of the products. We recommend that you always check suitability of the products for a specific intended application in a practically oriented test. Please consult igus®. For reasons relating to ongoing technical developments, we reserve the right to implement technical modifications and improvement of the products at any time. All catalog dimensions and values apply only to standard material igumid G / GLW.

Subject to printing errors. The terms "igus", "readychain", "readycable", "chainflex", "e-chain", "e-chainsystem", "energy chain system", "energy chain", "e-ketten", "e-kettensysteme", "flizz", "easy chain", "triflex", "twisterchain", "igubal", "iglidur", "drylin", "xiros", "xirodu", "invis", "vector", "manus", "dry-tech" and "plastics for longer life" are legally protected trademarks for igus® GmbH/Cologne in the Federal Republic of Germany and, where applicable, in some foreign countries.

# Applications: long strokes

## Solutions with igus® e-chainsystems®

igus® e-chainsystems® guide and protect moving cables and hoses on automated equipment. They can be used in a wide variety of applications; some examples following. More exciting examples

[www.igus.eu/eu/EKPraxis](http://www.igus.eu/eu/EKPraxis)



Find a video online

[www.vector-award.eu](http://www.vector-award.eu)



The world's longest e-chain® travel of 615 m with  
igus® rol e-chains® and chainflex® cables in a power station



System E6, side mounted, in high-speed camera positioning system - high speeds and low vibration



Long travel length with the super-alu-trough in a cold store



igus® steel guide trough used in a shelf conveyor application, series 3500 and chainflex® cables



igus® steel guide trough used in a long travel robotics application



e-chain® Series 4040RHD rolling e-chain® in an igus® super-alu-trough = up to 75% less driving power



Travel up to 195 m with the igus® System E4, safely guided in an igus® steel trough

# Applications: machine tools



Portal milling machine with fully closed E4 e-tube  
with special material igumid HT. 850°C hot chips - no problem



Series E4.42 in a machine tool, completely assembled with igus® chainflex® cables

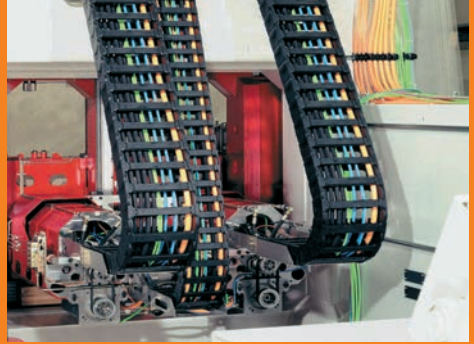

readychain® with combined motions on tooling machines. Turnkey delivered with special parts for your machines



E2/000 dirt resistant e-chain®, which saves installation space - here machine tool for workpieces



Machine tool gantry with various E4 e-chains® - fast movements and high cycle counts



E4 e-chain® was used here in curved sections with a 45 m travel distance



Short travel lengths and high accelerations with Series E2 mini

# Applications: cranes & offshore

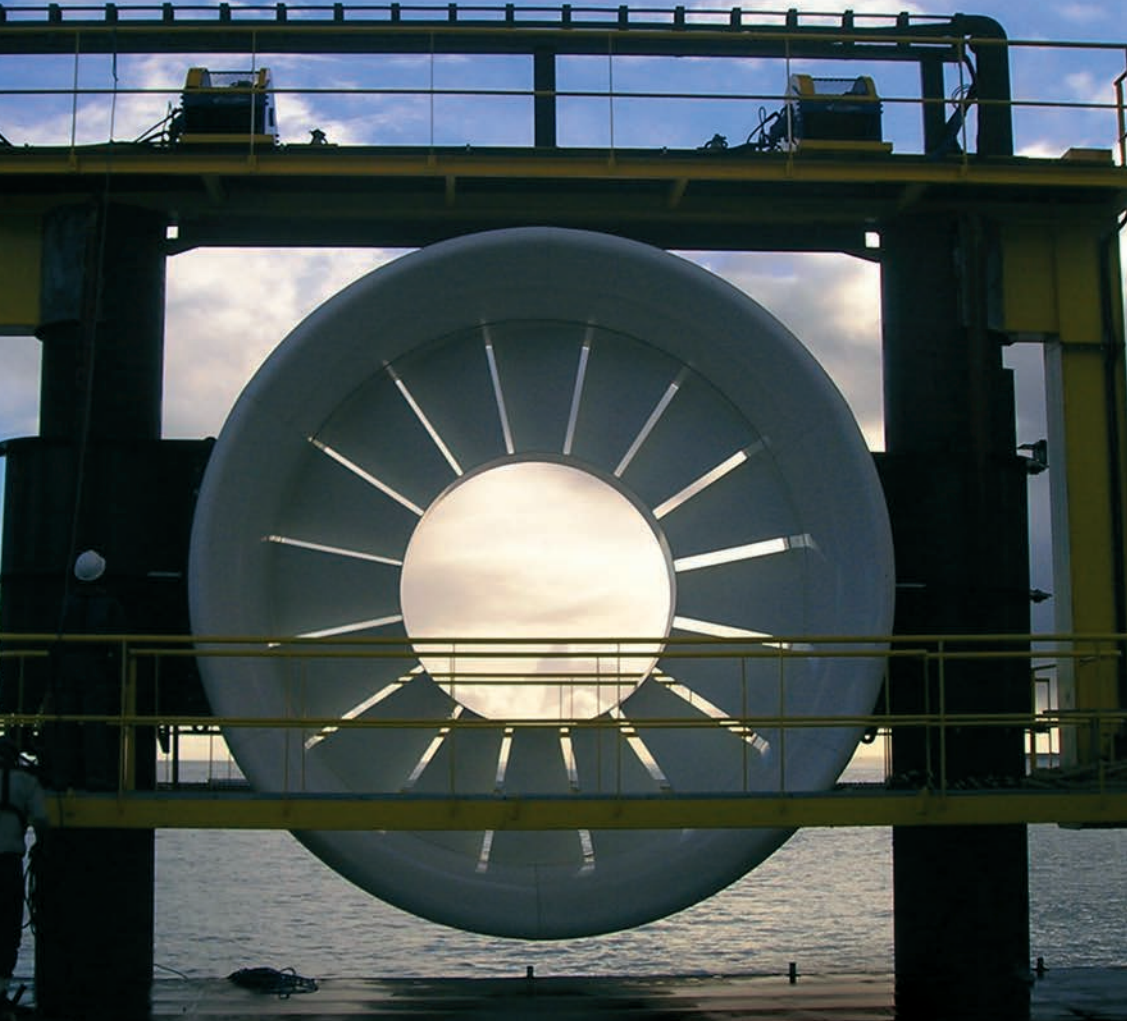

OpenHydro tidal turbine generates electric power through the inflow and outflow of water at low and high tide. Series 4040 protects the deployed chainflex® cables during the lifting and lowering movements of the turbine and also protects them against aggressive ambient conditions. The travel distance amounts to approx. 20 meters in a vertical direction above and under water with the robust e-chain® guided in a steel trough. The vertical travel is transformed into a horizontal stroke by turning through 90 degrees.





Seawater resistant super-alu-trough in a RTG-crane. Long travel with the E4 system



Stable guidance without oscillation. Long travel with 32 m, crane operating speed 80 m/min.



E4 as ZigZag version in a crane. The E4-Series guarantee very high availability of the facility

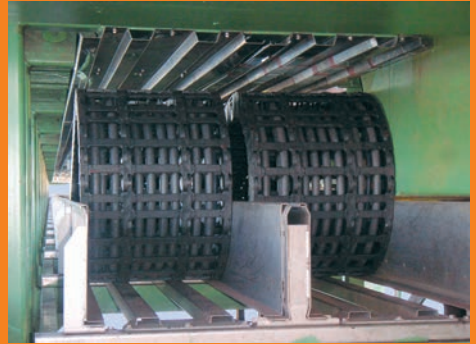

E4 with extension link at a ship loader for coal unloading. Travel 105 m, speed 240 m/min, load 53 kg/m



Installation of an E4.1 e-chain® Series 800 in an igus® steel guide trough



e-chain® at the mast of the shelf conveyor rolls from one aluminum guide trough to the opposite one

# Applications: high speed & smooth running



Long travel and side mounted  
installation with the vibration-free  
and low noise Series E6.29 in this  
camera application



System E6 in a pick and place robot.  
Handles injection molded CD covers in a split second



E6 accelerates the work sequences in the case of  
this application for wafer handling -  $a = 4 \text{ m/s}^2$ ,  $v = 6 \text{ m/s}$



igus® Series E3.15 side  
mounted in a flat-bed scanner



igus® System E6 - High  
acceleration (8 g) and ESD safety

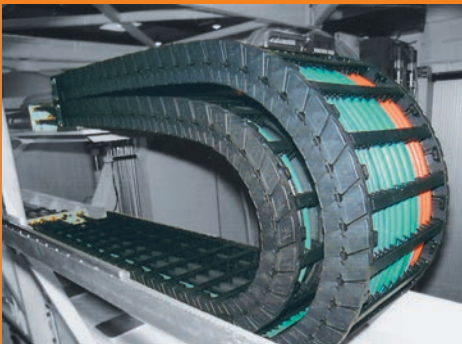

Nested e-chains® reduce vibrations  
and improve milling accuracy Series E6.62



Low-noise low vibrations with E6.  
Designed to withstand high dynamic loads

# Applications: circular & 3D-movements

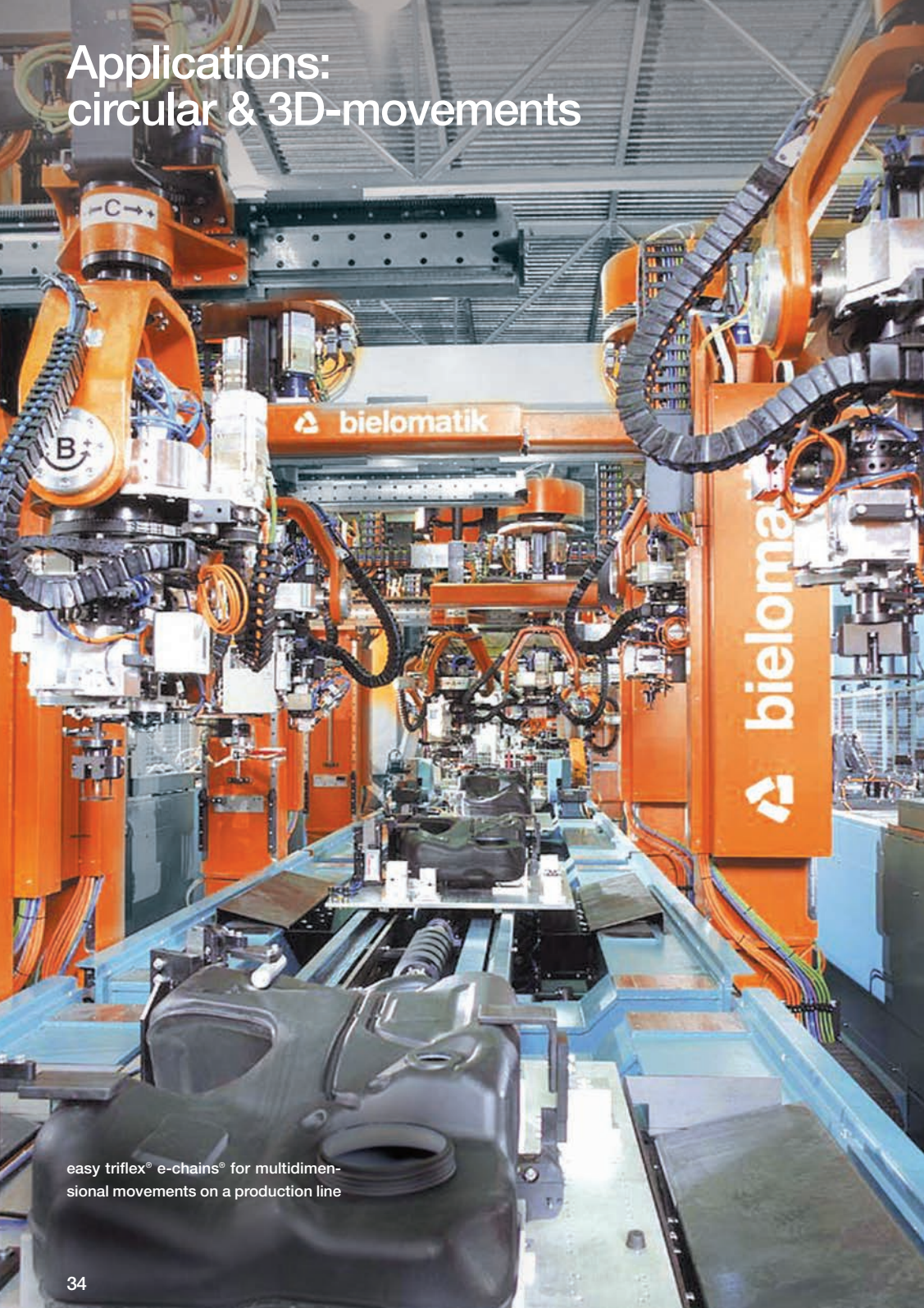

easy triflex® e-chains® for multidimensional movements on a production line



E4 "RBR"- application in a telescope - cold temperatures and snow - failsafe



Laser measuring telescope with triflex® R. Rotary motion in both directions  $\leq 310^\circ$  possible at high speeds  $\leq 20$  m/s



An igus® twisterband guides the energy of the 5-axis cutting heat in this wood working machine, safe and cost-effective



Circular movement with System E4 - safe energy supply on cranes



triflex® R in a magnesium die-casting industry (heat, dirt, oil, metal chips, dust, etc.) - failsafe



E2 mini, Series B15 - The motor spindle has a swivelling range of approx.  $210^\circ$

# Applications: various installation examples



Data gloves with easy chain® Series E03 - Protect the sensors which makes it easier to take off and put on the gloves. Inner height of 5 mm

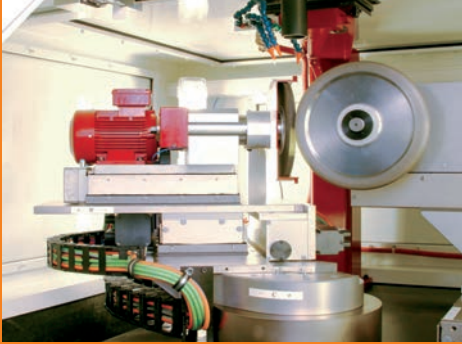

Two fully harnessed E2/000 e-chains® with high fill weight, side mounted



Unsupported application with harnessed e-chainsystem® E4



E2/000 - high stability in this elevator with an height of 160 m



Series R68 works in an apple-sorting-machine: humidity and dirt



Standing application with System E4 and fixed mounting brackets

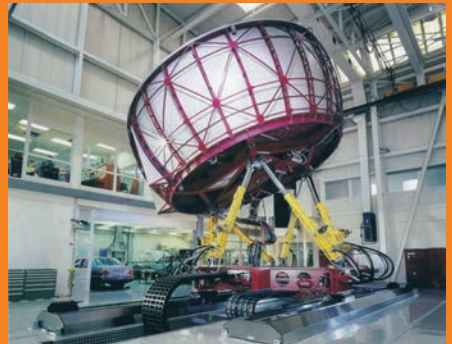

Drive simulator. High fill weights (60 kg/m) with E4 System

# Products overview

## Low priced, easy to fill

Simply press cables in  
**easy chain®** | Version E



Split crossbar along the outer radius. (Some series available with multiple chamber system) ▶ from page 138

Simply press cables in  
**easy chain®** | Version Z



Split crossbar along the inner radius. (Some series available with multiple chamber system) ▶ from page 138



## Cost effective

**e-chain®** on one strip  
**System E1**



Snap-open lids along the outer radius, very easy to fill ▶ from page 164

## Smallest e-chains®

Smallest sizes, one-piece  
**E2 micro** | Non snap-open



Non snap-open. Smallest inner heights and bending radii ▶ from page 196

Smallest sizes, one-piece  
**E2 micro** | Snap-open



Snap-open along inner radius with film-hinge ▶ from page 196

Smallest sizes, two-piece  
**E2 micro** | Snap-open



Snap-open along outer radius ▶ from page 196



## Allrounder e-chains® and e-tubes

Small sizes, two-piece  
**E2 mini** | Snap-open



Snap-open along inner radius, double stop dog system ▶ from page 220

Medium sizes, **e-chain®**, two-piece  
**E2/000** | Snap-open



Snap-open along inner radius. High stability, quiet motion ▶ from page 240

Medium sizes, **e-chain®**, two-piece  
**E2/000** | Snap-open



Snap-open along outer radius. High stability, quiet motion ▶ from page 240



For simple applications 



Zip fastening e-chains<sup>®</sup> and e-tubes 

Loop e-chains<sup>®</sup>  
snapchain

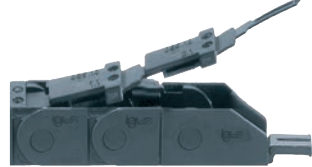

Fast assembly with zipper  
zipper | e-chains<sup>®</sup>

Fast assembly with zipper  
zipper | e-tubes



 Adjustable loops, to be opened along the inner (TZ) and outer (TE) radius  from page 170

 Zip-open along outer radius, fast assembly  from page 174

 Zip-open along outer radius, fast assembly  from page 174



Small e-chains<sup>®</sup> 



Small sizes, one-piece  
E2 mini | Non snap-open



Small sizes, one-piece  
E2 mini | Snap-open with film-hinge

Small sizes, two-piece  
E2 mini | Snap-open



 Non snap-open. Large pins and double stop dog system  from page 220

 Snap-open along inner radius with film-hinge  from page 220

 Snap-open along outer radius, double stop dog system  from page 220



Medium sizes, half e-tube, two-piece  
E2/000 | Snap-open



Medium sizes, e-tube, two-piece  
E2/000 | Snap-open

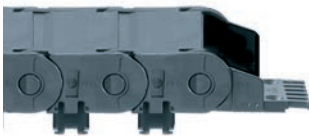

Chip protection 

Snap-open along inner radii  
E2 e-tubes | R100



 Snap-open along inner radius. High stability, quiet motion  from page 240

 Snap-open along inner radius. High stability, quiet motion  from page 240

 Snap-open on both sides. Excellent chip protection  from page 298

# Products overview

## ◀◀ Protection against dirt, dust and chips ▶▶

Snap-open along outer radii  
**E2 e-tubes** | R100



21-50  
 Snap-open on both sides.  
 Excellent chip protection  
 ▶ from page 298

Removable lids along outer radius  
**E2 e-tubes** | R



25-45  
 Removable lids along outer  
 radius. Small pitch for smooth  
 operation ▶ from page 320

Snap-open along outer radius  
**RX e-tubes** | Extremely chip repellent



41-73  
 Extremely chip repellent without  
 undercuts, projecting edges  
 and gaps ▶ from page 342

## E4.1 light - light design ▶▶ E4/light - Low weight, economic and stable

4-piece, swivelable crossbars, less weight  
**E4.1 light** | Crossbars every link



**New** in this catalog

38-48  
 Light design, high dynamics,  
 cost effective, swivelable  
 crossbars ▶ from page 422

4-piece, snap-open  
**E4/light** | Crossbars every link



56-86  
 Light and stable. Inner-/outer-  
 link design. Save weight and  
 money! ▶ from page 434

4-piece, snap-open  
**E4/light** | Crossbars every 2<sup>nd</sup> link



56-86  
 Light and stable. Inner-/outer-  
 link design. Save weight and  
 money! ▶ from page 434

## E6 - Extremely low-noise ▶▶

Super quiet, low vibration, cleanroom  
**E6** | e-chains®



29-80  
 No pin/bore connections, minimal  
 abrasion, snap-open along  
 both radii ▶ from page 494

Super quiet, low vibration, cleanroom  
**R6** | e-tubes, removable lids



29-52  
 No pin/bore connections, minimal  
 abrasion, snap-open along  
 both radii ▶ from page 494

## E6.1 - 2<sup>nd</sup> generation ▶▶

Super quiet, low vibration, less weight  
**E6.1** | e-chains®



**New** in this catalog  
 No pin/bore connections,  
 crossbars removable along  
 both radii ▶ from page 532

**E4.1 - Universal E4 modular kit, e-chains®/e-tubes for almost any application** 

Standard, 4-piece, snap-open  
**E4.1** | Crossbars every link

Standard, 4-piece, snap-open  
**H4.1** | Crossbars every 2<sup>nd</sup> link

Standard, 4-piece, hinged, removable lids  
**R4.1** | e-tubes, fully enclosed

**New** in this catalog | **E4.112**



 Long travels, large unsupported lengths, snap-open  
▶ from page 362



 Long travels, large unsupported lengths, snap-open  
▶ from page 362



 Long travels, large unsupported lengths, snap-open  
▶ from page 362

**Highly flexible**  **Highly dynamic** 

4-piece, hinged, removable lids  
**E4/light** | e-tubes, fully enclosed

For highly dynamic applications, low-noise  
**T3** | e-chains® | T-band

Superquiet in small spaces  
**E3** | e-chains®



 Light and stable. Inner/outer-link design. Save weight and money! ▶ from page 434

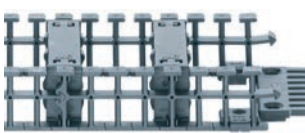

 Openable from both sides. Low-price for simple applications ▶ from page 476



 Snap-open along outer radius. Fast assembly, crossbars "on a string" ▶ from page 484

**Robotic- and 3D e-chains® and e-tubes** 

Robotic, 3D, chip-resistant  
**triflex® R TRC** | closed design

Robotic, 3D, simply press cables in  
**triflex® R TRE** | "easy" design

Robotic, 3D, light and economical  
**triflex® R TRL** | light design



 TRC: closed design, smooth and robust exterior  
▶ from page 546



 TRE: light and low-cost alternative with "easy" Design  
▶ from page 550



 TRL: lightweight and cost-effective 3D e-chain®  
▶ from page 554

# Products overview

## ◀◀ Robotic- and 3D ▶▶

Robotic, 3D, with snap lock mechanism  
**triflex® R TRLF** | light design



**New** in this catalog



Light-variant with snap lock mechanism. Openable by hand ▶ [from page 558](#)

## For 3D-applications ▶▶

3D applications  
**easy triflex®** | "easy" design

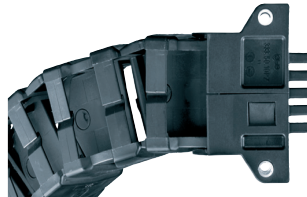

easy triflex®: "easy" Design, simple filling from 2 sides ▶ [from page 572](#)

## 3D, closed ▶▶

3D applications  
**triflex®** | Closed version



Protection against dirt and chips, combined circle- and stroke-movements ▶ [from page 582](#)

## chainfix strain relief, clamps

For maximum pull forces, adjustable  
**Clamps** | CFX | CFXL

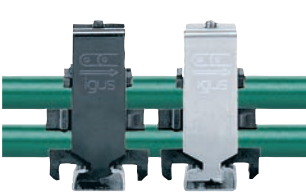

CFX standard clamps and CFXL with wide base for maximum pull forces. Galvanized or stainless steel (Material 1.4301) ▶ [from page 636](#)

For various possibilities  
**Multi-Clamps**



chainfix-Adapter. Save assembly time, space and money. Compact and modular. For small outer diameters ▶ [page 641](#)

## Further strain relief options

For universal tiewrap, bolted or clip-on  
**Tiewrap plates**

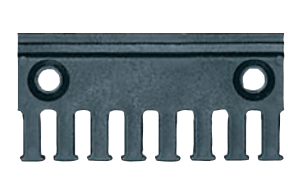

chainfix tiewrap plates as single parts, suitable for assembly in the KMA mounting brackets ▶ [from page 644](#)

## ◀◀

For top hat rail and C-profile  
**Nuggets**



Completely simple and universal cable fixation for top hat rail and C-profile ▶ [page 652](#)

## ▶▶

Strain relief for hoses  
**Blocks** Conventional | CFB

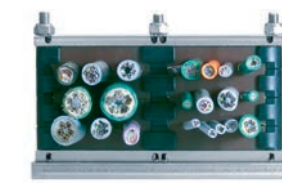

Conventional blocks and CFB® polymer strain relief connector system, for many cables in a very confined space ▶ [from page 653](#)

## Aluminum SuperTrough

Basic version, for general use  
**Aluminum "SuperTrough"**



The igus® standard guide trough. Very simple, modular assembly ▶ [from page 664](#)

**Circular movements** 

Circular movements, new generation **twisterchain® new** | Snap-open



 32-56 Circular e-chains®, rotary and spiral movements up to 540°, high loads ▶ **from page 594**

Circular movements, first generation **twisterchain® classic** | Snap-open



 28-56 First generation, openable crossbars on both sides, circular motions ▶ **from page 610**

**Rotary motion** 

Rotary motion, small space, compact **twisterband\*** (7000° rotation<sup>1)</sup>)

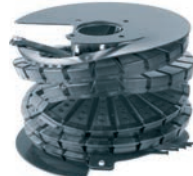

 9 - 22 Rotary motions in small spaces, 20 times around its own axis ▶ **from page 624**

Clip-on connection for the C-profile **Tiewrap plates**

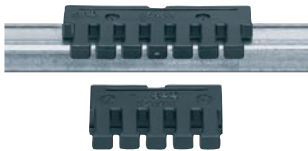

Clip-on connection for the C-profile. Easy to assemble and disassemble without any screws ▶ **from page 646**

High tensile forces, modular, clip-on **Clips**



For C-profiles, also suitable for assembly in the KMA mounting brackets and clip-on strain relief for crossbars ▶ **from page 648**

Separators with integrated strain relief **Strain relief separators**



Separator with integrated strain relief. Easy strain relief with cable tiewraps ▶ **from page 650**

 **Steel guide trough** 

Heavy-duty version, for Heavy Duty use **Aluminum "SuperTrough"**

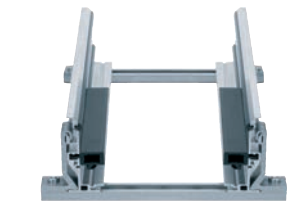

 87-236 Recommended for plant construction ▶ [www.igus.eu/eu/salun](http://www.igus.eu/eu/salun)

**Steel guide troughs** 

Stable, rugged for Heavy-Duty applications



 56-112 For applications in rough environments. Huge product range ▶ **from page 688**

**Support of the lower run** 

Support tray tool kit



Support tray tool kit for support of the lower run, cost effective ▶ **page 714**

# Products overview and...

## Further guide trough ▶▶

Energy supply for crane girders and indoor cranes, quickly installed



New in this catalog

Economical energy supply for crane girders and indoor cranes, quickly installed  
▶ from page 720

## Special solutions for long travels without guide troughs

Energy efficiency system for long travels  
System P4 | rol e-chain®

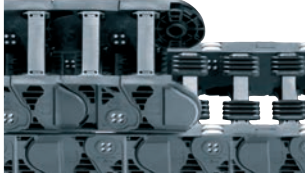

Reduce 57% energy consumption. For very long travels, high speeds ▶ from page 726

Rolling instead of gliding  
rol e-chain®



Reduction in drive power to less than 25 % for moving the e-chain® ▶ from page 734

## Enclosed plastic trough lbt flizz®



Enclosed polymer trough, low-cost  
▶ from page 748

## Small e-chains® in aluminum profile micro flizz®



Master long travels with the smallest e-chains® without failures ▶ from page 752

## Project Modular system for projects



Faster quotations, faster project planning  
▶ from page 760

## Configuration and design Design and calculate e-chains®

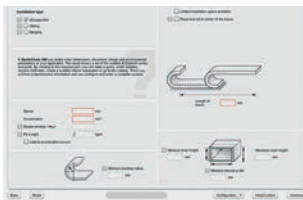

e-chain® comparison, configuration calculation with one online-tool  
▶ [www.igus.eu/eu/quickchain100](http://www.igus.eu/eu/quickchain100)

## Configuration and design Automatically fill e-chains®

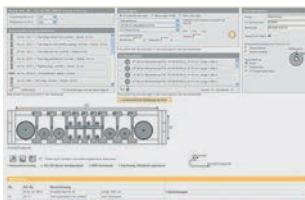

Optimize the available space in your e-chain® by using the shelving tool  
▶ [www.igus.eu/eu/quickfill](http://www.igus.eu/eu/quickfill)

## Product finder Select robotic equipment



Easy selection of the e-chain® components for your robot system  
▶ [www.igus.eu/eu/quickrobot](http://www.igus.eu/eu/quickrobot)

Long travels without guide troughs  
autoglide

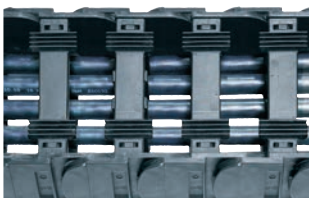

Self-guiding e-chainsystem®.  
No guide troughs required  
▶ from page 738

Upper run guide, unsupported travels 50 m  
guidelok | horizontal



Upper run guide for long travels,  
unsupported in critical chip areas  
▶ from page 744

Safe vertical guidance  
guidelok slimline "F"



For e-chains® in high-speed rack feeders.  
No swinging of the e-chain®, high reliability  
through guiding rails ▶ from page 746

igus® online-tools, easy to use, no registration required ▶▶

Product finder  
Find and compare e-chains®



Quickly find your required e-chain®. You  
have just to specify the inner dimensions  
▶ [www.igus.eu/eu/quickchain](http://www.igus.eu/eu/quickchain)

Express selection  
Configure e-chains®

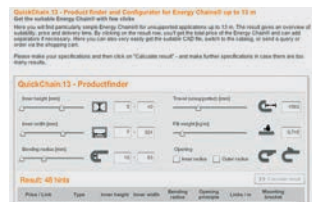

Quickly and easily find an e-chain® for  
unsupported applications up to 13 m travel  
▶ [www.igus.eu/eu/quickchain13](http://www.igus.eu/eu/quickchain13)

Service life predictor  
Calculate lifetime of e-chains®



The very reliable igus® lifetime calculator  
based on a huge databank of tests  
▶ [www.igus.eu/eu/echainlife](http://www.igus.eu/eu/echainlife)

3D CAD design  
For e-chains® with rotary motion

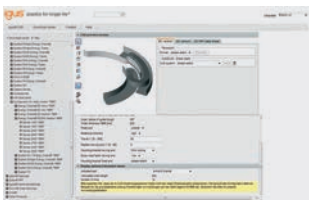

Generate 3D-CAD models for e-chains®  
with rotary motion with a few clicks  
▶ [www.igus.eu/eu/quickcadcm](http://www.igus.eu/eu/quickcadcm)

3D CAD design  
For twisterchain® models



Generate 3D-CAD drawings for  
twisterchain® models with a few clicks  
▶ [www.igus.eu/eu/quickcadctd](http://www.igus.eu/eu/quickcadctd)

Quickly find the right e-chains® and cables  
the-chain

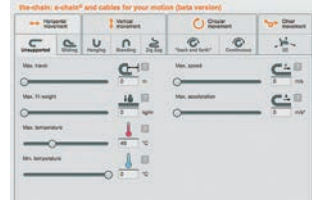

the-chain: e-chain® and cables for my move-  
ment. A website for all types of motion  
▶ [www.igus.eu/eu/the-chain](http://www.igus.eu/eu/the-chain)







# Technical Details | System E1 | snapchain | zipper

## Legend

- Standard
- Limited suitability
- ▲ Options
- Especially suitable

Opening principle



Series / Product

Inner height  $h_i$  [mm] +  $\varnothing$  cable max.



Inner width  $B_i$  [mm] from - to



Outer height  $h_a$  [mm]



Outer width  $B_a$  [mm] from - to



Bending radius  $R$  [mm] from - to

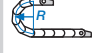

## System E1 - Modular, 1-piece strip design for simple applications

e-chains® | Snap-open along the outer radius



Series / Product	Inner height $h_i$ [mm] + $\varnothing$ cable max.	Inner width $B_i$ [mm] from - to	Outer height $h_a$ [mm]	Outer width $B_a$ [mm] from - to	Bending radius $R$ [mm] from - to
E1.10	10 $\varnothing$ 9	13	15,5	16,5	18
E1.17	17 $\varnothing$ 15	21 - 44	25	26 - 49	28
E1.18	18 $\varnothing$ 16	15	26	20	28
E1.20	20 $\varnothing$ 18	15	27	22	28

## snapchain - Fit cable assemblies quickly in bunches

e-chains® | Loops to be opened along the outer radius



Series / Product	Loop length	Inner height $h_i$ [mm] + $\varnothing$ cable max.	Inner width $B_i$ [mm] from - to	Outer height $h_a$ [mm]	Outer width $B_a$ [mm] from - to	Bending radius $R$ [mm] from - to
TE14.50	Loop length: 50 mm	-	-	-	28 - 125	
TE26.120	Loop length: 120 mm	-	-	-	63 - 200	

e-chains® | Loops to be opened along the inner radius



Series / Product	Loop length	Inner height $h_i$ [mm] + $\varnothing$ cable max.	Inner width $B_i$ [mm] from - to	Outer height $h_a$ [mm]	Outer width $B_a$ [mm] from - to	Bending radius $R$ [mm] from - to
TZ14.50	Loop length: 50 mm	-	-	-	28 - 125	
TZ26.120	Loop length: 120 mm	-	-	-	63 - 200	

## zipper e-chains® and e-tubes - Lightning-fast opening and closing

e-chains® | Zip-open along the outer radius





























Series / Product	Inner height $h_i$ [mm] + $\varnothing$ cable max.	Inner width $B_i$ [mm] from - to	Outer height $h_a$ [mm]	Outer width $B_a$ [mm] from - to	Bending radius $R$ [mm] from - to
047	9 $\varnothing$ 7	10 - 16	12,5	16 - 22	18 - 38
07	10,3 $\varnothing$ 8	6 - 64	15	12,5 - 71	18 - 48
09	15 $\varnothing$ 12,5	10 - 50	19,3	18,2 - 58,2	28 - 48
15	17 $\varnothing$ 15	15 - 100	24	26 - 113	38 - 180
17	32 $\varnothing$ 28	15 - 100	39	25,5 - 113	63 - 125

e-tubes | Zip-open along the outer radius



Series / Product	Inner height $h_i$ [mm] + $\varnothing$ cable max.	Inner width $B_i$ [mm] from - to	Outer height $h_a$ [mm]	Outer width $B_a$ [mm] from - to	Bending radius $R$ [mm] from - to
R07	10,3 $\varnothing$ 8	10 - 50	15	16,5 - 57	38 - 48
R09	15 $\varnothing$ 12,5	10 - 50	19,3	18,2 - 58,2	48 - 100
R15	17 $\varnothing$ 15	25 - 80	24	36 - 94	63 - 180
R17	32 $\varnothing$ 28	15 - 63	39	26 - 74	63 - 125

Pitch [mm]	Unsupported fill weight max [kg/m]	Unsupported length $FL_B$ max [m]	Long travel max [m]	Interior separation possibilities			ESD/ATEX  	Cleanroom 	UL-V2 / V0 	Low noise 	Price index 	Page
				Separators 	Full-width shelves 	Shelves 						
20	upon request	-	-	-	-	-	○	●	▲	●		166
25,5	upon request	-	-	-	-	-	○	●	▲	●		167
25,25	upon request	-	-	-	-	-	○	●	▲	●		168
25	upon request	-	-	-	-	-	○	●	▲	●		169
30,5	-	-	-	-	-	-	-	-	▲	●		172
56	-	-	-	-	-	-	-	-	▲	●		173
30,5	-	-	-	-	-	-	-	-	▲	●		172
56	-	-	-	-	-	-	-	-	▲	●		173
13	0,25	0,4	-	-	-	-	▲	●	▲	■		178
20	0,4	0,55	-	-	-	-	▲ <sup>2)</sup>	●	▲	■		180
20	0,7	1	-	●	●	-	▲ <sup>2)</sup>	●	▲	■		184
30,5	1,5	1,2	-	●	●	-	▲	●	▲	■		188
30,5	1	1	-	●	●	-	▲	●	▲	■		192
20	0,4	0,55	-	-	-	-	▲	●	▲	■		182
20	0,7	1	-	-	-	-	▲	●	▲	■		186
30,5	1,5	1,2	-	●	●	-	▲	●	▲	■		190
30,5	1,5	1,2	-	●	●	-	▲	●	▲	■		194

2) ESD-option, available from stock

# Technical Details | E2 micro | E2 mini

## Legend

- Standard
- Limited suitability
- ▲ Options
- Especially suitable

Opening principle



Series / Product

Inner height  $h_i$  [mm] +  $\varnothing$  cable max.



Inner width  $B_i$  [mm] from - to



Outer height  $h_a$  [mm]



Outer width  $B_a$  [mm] from - to



Bending radius  $R$  [mm] from - to

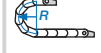

## E2 micro - One-piece e-chains®, small sizes

### Non snap-open



Series / Product	Inner height $h_i$ [mm] + $\varnothing$ cable max.	Inner width $B_i$ [mm] from - to	Outer height $h_a$ [mm]	Outer width $B_a$ [mm] from - to	Bending radius $R$ [mm] from - to
03	5 $\varnothing$ 3,5	5 - 10	8	8,7 - 13,7	10 - 28
04	7 $\varnothing$ 5	7 - 30	10	12 - 35	15 - 48
045	10,3 $\varnothing$ 8	6 - 64	12,5	12 - 70	18 - 83
05	10 $\varnothing$ 8	6 - 64	12	10 - 68	18 - 38
06	10,5 $\varnothing$ 8	6 - 64	15	12,5 - 71	18 - 38
08	15 $\varnothing$ 12	10 - 50	19,3	18,2 - 58,2	25 - 48

### Snap-open along inner radius



074	10,9 $\varnothing$ 8,5	10	15	18,2	18 - 38
094	14,3 $\varnothing$ 13	10	19,3	18,2	28 - 48

### Snap-open along outer radius



B07	10,3 $\varnothing$ 8	16 - 40	15	22,5 - 47	18 - 38
B09	14,3 $\varnothing$ 12,8	16 - 40	19,3	24,2 - 48,2	28 - 48

## E2 mini - One/two-piece e-chains®, small and medium sizes

### Non snap-open



10	18 $\varnothing$ 16	15 - 100	23	26 - 113	28 - 180
11.031	23 $\varnothing$ 21	31	28	41,2	45 - 70
11.080	28 $\varnothing$ 25	80	33,4	93	38
11.1/11.2	41 $\varnothing$ 22,5	15 - 25	46	25,5 - 35,5	40 - 100

### Snap-open along inner radius















14	20 $\varnothing$ 16	15 - 50	25	26 - 61	28 - 125
B15i	17 $\varnothing$ 14	15 - 100	23	26 - 113	38 - 180
B17i	32 $\varnothing$ 28	38	39	48,5	48 - 125
F17	32 $\varnothing$ 14	15	39	26	48

### Snap-open along outer radius



B15	17 $\varnothing$ 14	15 - 100	23	26 - 113	38 - 180
B17	32 $\varnothing$ 28	15 - 100	39	25,5 - 113	48 - 125

Pitch [mm]	Unsupported fill weight max [kg/m]	Unsupported length $FL_B$ max [m]	Long travel max [m]	Interior separation possibilities			ESD/ATEX igus.eu/used	Cleanroom	UL-V2 / V0	Low noise	Price index	Page
				Separators	Full-width shelves	Shelves						
												
10	0,24	0,4	-	-	-	-	○	○	●	■	●●●	200
16,7	0,35	0,5	-	-	-	-	▲	○	▲	●	●●●	202
13	0,25	0,5	-	▲	-	-	▲	○	▲	■	●●●	204
20	0,375	0,55	-	-	-	-	▲	○	▲	●	●●●	206
20	0,48	0,6	-	▲	-	-	▲	○	▲	●	●●●	208
20	0,75	1	-	-	-	-	▲	○	▲	●	●●●	216
20	0,4	0,55	-	-	-	-	○	●	●	●	●●●	212
20	0,7	1	-	-	-	-	○	●	●	●	●●●	214
20	0,4	0,55	-	-	-	-	○	●	▲	■	●●●	210
20	0,7	1	-	●	●	-	○	●	▲	■	●●●	218
30,5	1,5	1,2	-	●	-	-	▲	●	▲	●	●●●	224
30,5	1,5	1,35	-	-	-	-	▲	○	▲	●	●●●	226
30,5	1,5	1,5	-	-	-	-	▲	○	▲	●	●●●	228
30,5	1,5	1,35	-	-	-	-	▲	○	▲	●	●●●	230
30,5	0,5	0,65	-	-	-	-	▲	■	●	●	●●●	232
30,5	1,5	1,2	-	●	●	-	▲	●	▲	●	●●●	234
30,5	1	1	-	●	●	-	▲	○	▲	●	●●●	236
30,5	1,5	1,2	-	●	●	-	▲	○	●	●	●●●	238
30,5	1,5	1,2	-	●	●	-	▲	●	▲	●	●●●	234
30,5	1	1	-	●	●	-	▲	○	▲	●	●●●	236

# Technical Details | E2/000

## Legend

- Standard
- Limited suitability
- ▲ Options
- Especially suitable

Opening principle



Series / Product

Inner height  $h_i$  [mm] +  
ø cable max.



Inner width  $B_i$  [mm]  
from - to



Outer height  $h_a$  [mm]



Outer width  $B_a$  [mm]  
from - to



Bending radius  $R$  [mm]  
from - to

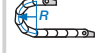

## E2/000 e-chain® - Two-piece e-chains®, the E2 standard!

### e-chains® | Snap-open along inner radius



Series / Product	Inner height $h_i$ [mm] + ø cable max.	Inner width $B_i$ [mm] from - to	Outer height $h_a$ [mm]	Outer width $B_a$ [mm] from - to	Bending radius $R$ [mm] from - to
1400	21 ø 18	15 - 125	28	28,5 - 138,5	35 - 180
2400	25 ø 23	25 - 125	35	41 - 141	55 - 250
2600	35 ø 32	50 - 175	50	66 - 194	63 - 250
3400	45 ø 42	50 - 250	64	70 - 270	75 - 300

### e-chains® | Snap-open along outer radius

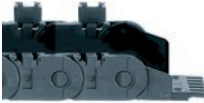

Series / Product	Inner height $h_i$ [mm] + ø cable max.	Inner width $B_i$ [mm] from - to	Outer height $h_a$ [mm]	Outer width $B_a$ [mm] from - to	Bending radius $R$ [mm] from - to
1500	21 ø 18	15 - 125	28	28,5 - 138,5	35 - 180
2500	25 ø 23	25 - 125	35	41 - 141	55 - 250
2700	35 ø 32	50 - 175	50	66 - 194	63 - 250
3500	45 ø 42	50 - 250	64	70 - 270	75 - 300
255	24 ø 22	38 - 103	35	54 - 119	55 - 250

### Half e-tubes | Snap-open along inner radius















Series / Product	Inner height $h_i$ [mm] + ø cable max.	Inner width $B_i$ [mm] from - to	Outer height $h_a$ [mm]	Outer width $B_a$ [mm] from - to	Bending radius $R$ [mm] from - to
1450	21 ø 18	15 - 125	28	28,5 - 138,5	75 - 180
2450	25 ø 23	25 - 125	35	41 - 141	75 - 250
2650	35 ø 32	50 - 175	50	66 - 194	100 - 250
3450	45 ø 42	50 - 250	64	70 - 270	125 - 300

### e-tubes | Snap-open along inner radius



Series / Product	Inner height $h_i$ [mm] + ø cable max.	Inner width $B_i$ [mm] from - to	Outer height $h_a$ [mm]	Outer width $B_a$ [mm] from - to	Bending radius $R$ [mm] from - to
1480	21 ø 18	15 - 125	28	28,5 - 138,5	75 - 180
2480	25 ø 23	25 - 125	35	41 - 141	75 - 250
2680	35 ø 32	50 - 175	50	66 - 194	100 - 250
3480	45 ø 42	50 - 250	64	70 - 270	125 - 300

Pitch [mm]	Unsupported fill weight max [kg/m]	Unsupported length $FL_B$ max [m]	Long travel max [m]	Interior separation possibilities			ESD/ATEX igus.eu/igus.esd	Cleanroom	UL-V2 / V0	Low noise	Price index	Page
				Separators	Full-width shelves	Shelves						
												
33,3	2	1,75	75 <sup>1)</sup>	●	●	-	▲	○	▲	●	●●●●	246
46	5	2,25	100 <sup>1)</sup>	●	●	●	▲	●	▲	●	●●●●	258
56	8	2,75	120 <sup>1)</sup>	●	●	●	▲	○	▲	●	●●●●	270
67	13	3	150 <sup>1)</sup>	●	●	●	▲	○	▲	●	●●●●	282
33,3	2	1,75	75	●	●	-	▲ <sup>2)</sup> ■	○	▲	●	●●●●	246
46	5	2,25	100	●	●	●	▲ <sup>2)</sup> ■	●	▲	●	●●●●	258
56	8	2,75	120	●	●	●	▲ <sup>2)</sup> ■	○	▲	●	●●●●	270
67	13	3	150	●	●	●	▲	○	▲	●	●●●●	282
27,8	2	1,8	100	●	●	●	▲	●	▲	■	●●●●	294
33,3	2	1,75	75 <sup>1)</sup>	●	●	-	●	○	▲	●	●●●●	252
46	5	2,25	100 <sup>1)</sup>	●	●	▲	●	○	▲	●	●●●●	264
56	8	2,75	120 <sup>1)</sup>	●	●	●	●	○	▲	●	●●●●	276
67	13	3	150 <sup>1)</sup>	●	●	●	▲	○	▲	●	●●●●	288
33,3	2	1,75	75 <sup>1)</sup>	●	●	-	▲	○	▲	○	●●●●	252
46	5	2,25	100 <sup>1)</sup>	●	●	▲	▲	○	▲	○	●●●●	264
56	8	2,75	120 <sup>1)</sup>	●	●	●	▲	○	▲	○	●●●●	276
67	13	3	150 <sup>1)</sup>	●	●	●	▲	○	▲	○	●●●●	288

1) Conditionally suitable in inner radii 2) ESD-option, available from stock







Pitch [mm]	Unsupported fill weight max [kg/m]	Unsupported length $FL_B$ max [m]	Long travel max [m]	Interior separation possibilities			ESD/ATEX igus.eu/igus 	Cleanroom 	UL-V2 / V0 	Low noise 	Price index	Page
				Separators 	Full-width shelves 	Shelves 						
30,5	1,5	1,2	-	●	-	-	-	○	▲	○	●●●	302
46	8	2,25	-	●	●	●	▲	○	▲	○	●●●	306
58,8	10	2,5	-	●	●	●	▲	○	▲	○	●●●	314
30,5	1,5	1,2	-	●	-	-	-	○	▲	○	●●●	302
46	8	2,25	-	●	●	●	▲	○	▲	○	●●●	306
58,8	10	2,5	-	●	●	●	▲	○	▲	○	●●●	314
30,3	1	1,5	50	●	▲	-	▲	○	▲	●	●●●	324
33,3	8	2,3	75	●	●	●	▲	○	▲	●	●●●	330
36	10	2,5	100	●	●	●	▲	○	▲	●	●●●	336
32	4	1,7	-	-	-	-	▲	○	▲	●	●●●	346
40	6	1,8	-	-	-	-	▲	○	▲	●	●●●	350
48	9	2,1	-	●	●	-	▲	○	▲	●	●●●	354
56	11	2,3	-	●	●	-	▲	○	▲	●	●●●	358

# Technical Details | System E4.1

## Legend

- Standard
- Limited suitability
- ▲ Options
- Especially suitable

Opening principle



Series / Product

Inner height  $h_i$  [mm] +  
ø cable max.



Inner width  $B_i$  [mm]  
from - to



Outer height  $h_a$  [mm]



Outer width  $B_a$  [mm]  
from - to



Bending radius  $R$  [mm]  
from - to

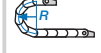

## Standard E4.1 - ONE e-chain® family for all applications

### E4.1 e-chains® | Crossbars every link - robust version



Series / Product	Inner height $h_i$ [mm] + ø cable max.	Inner width $B_i$ [mm] from - to	Outer height $h_a$ [mm]	Outer width $B_a$ [mm] from - to	Bending radius $R$ [mm] from - to
E4.21	21 ø 18	30 - 140	28	44 - 154	38 - 200
E4.28	28 ø 25	40 - 300	42	60 - 320	55 - 250
E4.32	32 ø 28	50 - 400	54	73 - 423	63 - 300
E4.42	42 ø 38	50 - 400	64	76 - 426	75 - 350
E4.56	56 ø 50	50 - 600	84	84 - 634	135 - 500
E4.80	80 ø 72	50 - 600	108	100 - 650	150 - 1000
E4.112 <b>New*</b>	112 ø 100	50 - 600	140	102 - 652	200 - 1000
800	200 ø 184	200 - 600	236	260 - 660	325 - 1000
840	204 ø 184	100 - 563	236	160 - 623	325 - 1000
E4.350	350 ø 315	400 - 800	450	540 - 940	500 - 1000

### H4.1 e-chains® | Crossbars every 2<sup>nd</sup> link - standard version











Series / Product	Inner height $h_i$ [mm] + ø cable max.	Inner width $B_i$ [mm] from - to	Outer height $h_a$ [mm]	Outer width $B_a$ [mm] from - to	Bending radius $R$ [mm] from - to
H4.32	32 ø 28	50 - 400	54	73 - 423	63 - 300
H4.42	42 ø 38	50 - 400	64	76 - 426	75 - 350
H4.56	56 ø 50	50 - 600	84	84 - 634	135 - 500
H4.80	80 ø 72	50 - 600	108	100 - 650	150 - 1000
H4.112 <b>New*</b>	112 ø 100	50 - 600	140	102 - 652	200 - 1000

### R4.1 e-tube | Fully enclosed - protection against chips, dust and dirt

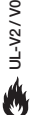

Series / Product	Inner height $h_i$ [mm] + ø cable max.	Inner width $B_i$ [mm] from - to	Outer height $h_a$ [mm]	Outer width $B_a$ [mm] from - to	Bending radius $R$ [mm] from - to
R4.28	28 ø 25	50 - 300	42	70 - 320	75 - 250
R4.32	32 ø 28	50 - 300	54	73 - 323	125 - 300
R4.42	42 ø 38	50 - 300	64	76 - 326	125 - 350
R4.56	56 ø 50	75 - 462	84	109 - 497	150 - 500
R4.80	80 ø 72	150 - 462	108	200 - 513	200 - 1000
R4.112 <b>New*</b>	108 ø 100	200 - 400	140	102 - 652	250 - 1000

\* in this catalog

Pitch [mm]	Unsupported fill weight max [kg/m]	Unsupported length $FL_B$ max [m]	Long travel max [m]	Interior separation possibilities			ESD/ATEX  	Cleanroom 	UL-V2 / V0 	Low noise 	Price index 	Page
				Separators 	Full-width shelves 	Shelves 						

**Can be opened from both sides - the E4 standard!**









30,5	4	2,5	120	●	●	-	▲ <sup>2</sup> ■	1)	▲	▲■	●●●	370
46	10	2,5	200	●	●	●	▲ <sup>2</sup> ■	1)	▲	▲■	●●●	374
56	15	3,3	200	●	-	●	▲ <sup>2</sup> ■	1)	▲	▲■	●●●	380
67	37	4	300	●	-	●	▲ <sup>2</sup> ■	1)	▲	▲■	●●●	386
91	62,5	5	400	●	-	●	▲ <sup>2</sup> ■	1)	▲	▲■	●●●	392
111	80	6,2	400	●	-	●	▲ <sup>2</sup> ■	1)	▲	▲■	●●●	398
143	85	6,5	450	●	-	●	▲▲	1)	▲	▲■	●●●	404
250	90	8	450	●	-	●	▲■	○	▲	■	●●●	410
250	90	8	450	●	-	-	▲	○	▲	■	●●●	414
470	600	6,2	-	●	-	●	-	-	▲	-	●●●	418

56	15	3,3	200	●	-	●	▲■	1)	▲	▲■	●●●	380
67	37	4	300	●	-	●	▲■	1)	▲	▲■	●●●	386
91	62,5	5	400	●	-	●	▲■	1)	▲	▲■	●●●	392
111	80	6,2	400	●	-	●	▲■	1)	▲	▲■	●●●	398
143	85	6,5	450	●	-	●	▲■	1)	▲	▲■	●●●	404

46	10	2,5	200	●	●	●	▲■	1)	▲	▲■	●●●	374
56	15	3,3	200	●	-	●	▲■	1)	▲	▲■	●●●	380
67	37	4	300	●	-	●	▲■	1)	▲	▲■	●●●	386
91	62,5	5	400	●	-	●	▲■	1)	▲	▲■	●●●	392
111	80	6,2	400	●	-	●	▲■	1)	▲	▲■	●●●	398
143	85	6,5	450	●	-	●	▲■	1)	▲	▲■	●●●	404

1) In preparation / upon request 2) ESD-option, available from stock



Pitch [mm]	Unsupported fill weight max [kg/m]	Unsupported length $FL_B$ max [m]	Long travel max [m]	Interior separation possibilities			ESD/ATEX  	Cleanroom 	UL-V2 / V0 	Low noise 	Price index 	Page
				Separators 	Full-width shelves 	Shelves 						

**New snap-open mechanism. Crossbars are swivelable on both sides**

56	13	2,75	1)	●	-	●	▲	-	▲	▲■	●●●	426
67	26	3,75	1)	●	-	●	▲	-	▲	▲■	●●●	430

91	40	4	150	●	-	●	▲■	○	▲	●	●●●	440
91	40	4	150	●	-	●	▲ <sup>2)</sup> ■	○	▲	●	●●●	446
91	55	4,2	250	●	-	●	▲■	○	▲	●	●●●	452
91	55	4,6	250	●	-	●	▲ <sup>2)</sup> ■	○	▲	●	●●●	458
91	55	4,6	250	●	-	●	▲■	○	▲	●	●●●	464
143	50	4,5	400	●	-	●	▲■	○	▲	●	●●●	470

91	40	4	150	●	-	●	▲■	○	▲	●	●●●	440
91	40	4	150	●	-	●	▲■	○	▲	●	●●●	446
91	55	4,2	250	●	-	●	▲■	○	▲	●	●●●	452
91	55	4,6	250	●	-	●	▲■	○	▲	●	●●●	458
91	55	4,6	250	●	-	●	▲■	○	▲	●	●●●	464

91	40	4	150	●	-	●	▲■	○	▲	●	●●●	440
91	55	4,2	250	●	-	●	▲■	○	▲	●	●●●	452
91	55	4,6	250	●	-	●	▲■	○	▲	●	●●●	458
143	50	4,5	400	●	-	●	▲■	○	▲	●	●●●	470

1) upon request 2) ESD-option, available from stock

## Legend

- Standard
- Limited suitability
- ▲ Options
- Especially suitable

Opening principle



Series / Product

Inner height  $h_i$  [mm] +  $\varnothing$  cable max.



Inner width  $B_i$  [mm] from - to



Outer height  $h_a$  [mm]



Outer width  $B_a$  [mm] from - to



Bending radius  $R$  [mm] from - to

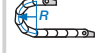

## T3 - 3-piece, T-shaped band e-chain®, very light weight and quiet

e-chain® | Openable from both sides

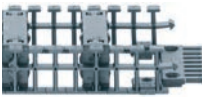

Series / Product	Inner height $h_i$ [mm] + $\varnothing$ cable max.	Inner width $B_i$ [mm] from - to	Outer height $h_a$ [mm]	Outer width $B_a$ [mm] from - to	Bending radius $R$ [mm] from - to
T3.29	29 $\varnothing$ 25	30 - 140	35	55 - 165	38

## E3 - 3-piece e-chain®, small, high dynamics, smooth and low noise

e-chain® | Zip open lids



Series / Product	Inner height $h_i$ [mm] + $\varnothing$ cable max.	Inner width $B_i$ [mm] from - to	Outer height $h_a$ [mm]	Outer width $B_a$ [mm] from - to	Bending radius $R$ [mm] from - to
E3.10	10 $\varnothing$ 8	20 - 60	15	32 - 72	15 - 48
E3.15	15 $\varnothing$ 13	20 - 60	20	32 - 72	32 - 75
E3.22	22 $\varnothing$ 20	20 - 60	27	32 - 72	44 - 75

## E6 - 6-piece e-chain®, for extremely low-noise operations

e-chain® | Crossbars every other link



Series / Product	Inner height $h_i$ [mm] + $\varnothing$ cable max.	Inner width $B_i$ [mm] from - to	Outer height $h_a$ [mm]	Outer width $B_a$ [mm] from - to	Bending radius $R$ [mm] from - to
E6.29	29 $\varnothing$ 25	30 - 140	35	46 - 156	55 - 150
E6.35	35 $\varnothing$ 31	30 - 140	42	50 - 160	55 - 150
E6.40	40 $\varnothing$ 36	40 - 300	54	60 - 320	63 - 200
E6.52	52 $\varnothing$ 46	40 - 300	65	64 - 324	75 - 250
E6.62	62 $\varnothing$ 54	50 - 400	84	86 - 436	115 - 350
E6.80L	80 $\varnothing$ 72	87 - 550	108	115 - 578	175
E6.80	80 $\varnothing$ 72	50 - 600	108	100 - 650	150 - 450

e-tube | Fully enclosed



Series / Product	Inner height $h_i$ [mm] + $\varnothing$ cable max.	Inner width $B_i$ [mm] from - to	Outer height $h_a$ [mm]	Outer width $B_a$ [mm] from - to	Bending radius $R$ [mm] from - to
R6.29	28 $\varnothing$ 25	30 - 120	35	46 - 136	55 - 150
R6.40	40 $\varnothing$ 36	50 - 125	54	70 - 145	63 - 200
R6.52	52 $\varnothing$ 46	50 - 175	66	74 - 199	75 - 250









## E6.1 - Even more smooth running, easier to open, for cleanroom applications

e-chain® | Crossbars removable along both radii



Series / Product	Inner height $h_i$ [mm] + $\varnothing$ cable max.	Inner width $B_i$ [mm] from - to	Outer height $h_a$ [mm]	Outer width $B_a$ [mm] from - to	Bending radius $R$ [mm] from - to
E61.29New*	29 $\varnothing$ 25	30 - 140	35	44 - 144	55 - 150
E61.52New*	52 $\varnothing$ 46	40 - 300	65	64 - 324	75 - 200

\* in this catalog

Pitch [mm]	Unsupported fill weight max [kg/m]	Unsupported length $FL_B$ max [m]	Long travel max [m]	Interior separation possibilities			ESD/ATEX 	Cleanroom 	UL-V2 / V0 	Low noise 	Price index 	Page
				Separators 	Full-width shelves 	Shelves 						
15	1	1,45	-	●	●	●	▲	■	▲	■	●●●	480
16,7	0,3	0,75	-	●	-	-	▲	■	▲	■	●●●	488
16,7	0,7	0,9	-	●	▲	-	▲	■	▲	■	●●●	490
16,7	0,85	1,2	-	●	▲	-	▲	■	▲	■	●●●	492
22	3	1,75	-	●	●	●	▲	■	▲	■	●●●	500
25	6	1,9	-	●	●	●	▲	■	▲	■	●●●	504
27,8	10	2,75	60 <sup>1)</sup>	●	●	●	▲	■	▲	■	●●●	508
30	15	3	80 <sup>1)</sup>	●	●	●	▲	■	▲	■	●●●	514
50	43	4	100 <sup>1)</sup>	●	●	●	▲	■	▲	■	●●●	520
65	25	2,5	-	●	-	●	▲	■	▲	■	●●●	524
65	55	5,25	120 <sup>1)</sup>	●	-	●	▲	■	▲	■	●●●	528
22	3	1,75	-	●	-	-	▲	■	▲	■	●●●	500
27,8	10	2,75	60 <sup>1)</sup>	●	-	-	▲	■	▲	■	●●●	508
30	15	3	80 <sup>1)</sup>	●	-	-	▲	■	▲	■	●●●	514
22	3,5	1,5	-	●	●	●	▲	■	▲	■	●●●	536
30	11	1,7	-	●	●	●	▲	■	▲	■	●●●	540

1) In preparation / upon request

# Technical Details | triflex® R

## Legend

- Standard
- Limited suitability
- ▲ Options
- Especially suitable

Opening principle



Series / Product

Inner height  $h_i$  [mm] +  $\varnothing$  cable max.



Inner width  $B_i$  [mm] from - to



Outer height  $h_a$  [mm]



Outer width  $B_a$  [mm] from - to



Bending radius  $R$  [mm] from - to



## triflex® R - 3D e-chain® for robot applications

### TRC | Closed design



Series / Product	Inner height $h_i$ [mm] + $\varnothing$ cable max.	Inner width $B_i$ [mm] from - to	Outer height $h_a$ [mm]	Outer width $B_a$ [mm] from - to	Bending radius $R$ [mm] from - to
TRC.30	12/10 $\varnothing$ 10	12/10	$\varnothing$ 34,5	$\varnothing$ 34,5	50
TRC.40	15/13 $\varnothing$ 13	15/13	$\varnothing$ 43	$\varnothing$ 43	58
TRC.60	22,5/19,5 $\varnothing$ 20,5	22,5/19,5	$\varnothing$ 65	$\varnothing$ 65	87
TRC.70	28/24 $\varnothing$ 26	28/24	$\varnothing$ 81	$\varnothing$ 81	110
TRC.85	33/28 $\varnothing$ 31	33/28	$\varnothing$ 94,5	$\varnothing$ 94,5	135
TRC.100	37,5/32,5 $\varnothing$ 35,5	37,5/32,5	$\varnothing$ 108	$\varnothing$ 108	145
TRC.125	43,3/43,3 $\varnothing$ 41	43,3/43,3	$\varnothing$ 135	$\varnothing$ 135	182

### TRE | "Easy" design for fast installation of cables and hoses



Series / Product	Inner height $h_i$ [mm] + $\varnothing$ cable max.	Inner width $B_i$ [mm] from - to	Outer height $h_a$ [mm]	Outer width $B_a$ [mm] from - to	Bending radius $R$ [mm] from - to
TRE.30	12/10 $\varnothing$ 10	12/10	$\varnothing$ 34,5	$\varnothing$ 34,5	50
TRE.40	15/13 $\varnothing$ 13	15/13	$\varnothing$ 43	$\varnothing$ 43	58
TRE.60	22,5/19,5 $\varnothing$ 20,5	22,5/19,5	$\varnothing$ 65	$\varnothing$ 65	87
TRE.70	28/24 $\varnothing$ 26	28/24	$\varnothing$ 81	$\varnothing$ 81	110
TRE.85	33/28 $\varnothing$ 31	33/28	$\varnothing$ 94,5	$\varnothing$ 94,5	135
TRE.100	37,5/32,5 $\varnothing$ 35,5	37,5/32,5	$\varnothing$ 108	$\varnothing$ 108	145
TRE.125	43,3/43,3 $\varnothing$ 41	43,3/43,3	$\varnothing$ 135	$\varnothing$ 135	182

### TRL | Light version with "easy" design



Series / Product	Inner height $h_i$ [mm] + $\varnothing$ cable max.	Inner width $B_i$ [mm] from - to	Outer height $h_a$ [mm]	Outer width $B_a$ [mm] from - to	Bending radius $R$ [mm] from - to
TRL.30	12/10 $\varnothing$ 10	12/10	$\varnothing$ 34,5	$\varnothing$ 34,5	50
TRL.40	15/13 $\varnothing$ 13	15/13	$\varnothing$ 45	$\varnothing$ 45	58
TRL.60	22,5/19,5 $\varnothing$ 20,5	22,5/19,5	$\varnothing$ 65	$\varnothing$ 65	87
TRL.70	28/24 $\varnothing$ 26	28/24	$\varnothing$ 81	$\varnothing$ 81	110
TRL.100	37,5/32,5 $\varnothing$ 35,5	37,5/32,5	$\varnothing$ 108	$\varnothing$ 108	145

### TRLF | Light version with snap lock mechanism



Series / Product	Inner height $h_i$ [mm] + $\varnothing$ cable max.	Inner width $B_i$ [mm] from - to	Outer height $h_a$ [mm]	Outer width $B_a$ [mm] from - to	Bending radius $R$ [mm] from - to
TRLF.65 <b>New*</b>	24,4 $\varnothing$ 22	24,4	$\varnothing$ 70,2	$\varnothing$ 70,2	100
TRLF.85 <b>New*</b>	32,8 $\varnothing$ 30	32,8	$\varnothing$ 94,5	$\varnothing$ 94,5	135
TRLF.100 <b>New*</b>	37,5 $\varnothing$ 35,5	37,5	$\varnothing$ 108	$\varnothing$ 108	145

\* in this catalog





# Technical Details | **easy triflex**<sup>®</sup> | **triflex**<sup>®</sup>

## Legend

- Standard
- Limited suitability
- ▲ Options
- Especially suitable

Opening principle



Series / Product

Inner height  $h_i$  [mm] +  
ø cable max.



Inner width  $B_i$  [mm]  
from - to



Outer height  $h_a$  [mm]



Outer width  $B_a$  [mm]  
from - to



Bending radius  $R$  [mm]  
from - to



## easy triflex<sup>®</sup> - For 3D motion, simple filling from 2 sides

"easy" design for fast installation of cables and hoses

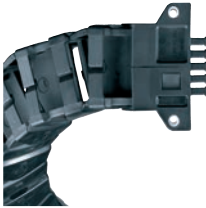

Series / Product	Inner height $h_i$ [mm] + ø cable max.	Inner width $B_i$ [mm] from - to	Outer height $h_a$ [mm]	Outer width $B_a$ [mm] from - to	Bending radius $R$ [mm] from - to
E332.25	25 ø 09	25	34	34	48 - 200
E332.32	32 ø 12	32	50	50	75 - 250
E332.50	50 ø 21	50	68	68	100 - 250
E332.75	75 ø 33	75	96	96	140 - 300
E333.25	25 ø 09	25	34	34	48 - 200
E333.32	32 ø 12	32	50	50	75 - 250
E333.50	50 ø 21	50	68	68	100 - 250
E333.75	75 ø 33	75	96	96	140 - 300

## triflex<sup>®</sup> - For 3D motion, closed

Closed design



Series / Product	Inner height $h_i$ [mm] + ø cable max.	Inner width $B_i$ [mm] from - to	Outer height $h_a$ [mm]	Outer width $B_a$ [mm] from - to	Bending radius $R$ [mm] from - to
332.16	16 ø 14	16	26	26	38 - 100
332.32	32 ø 28	32	50	50	75 - 250
332.50	50 ø 45	50	68	68	100 - 250
332.75	75 ø 67	75	96	96	140 - 300
333.16	16 ø 14	16	26	26	38 - 100
333.32	32 ø 28	32	50	50	75 - 250
333.50	50 ø 45	50	68	68	100 - 250
333.75	75 ø 67	75	96	96	140 - 300

Openable



Series / Product	Inner height $h_i$ [mm] + ø cable max.	Inner width $B_i$ [mm] from - to	Outer height $h_a$ [mm]	Outer width $B_a$ [mm] from - to	Bending radius $R$ [mm] from - to
352.50	50 ø 45	50	68	68	100 - 250
353.50	50 ø 45	50	68	68	100 - 250



# Technical Details | **twisterchain**® | **twisterband**

## Legend

- Standard
- Limited suitability
- ▲ Options
- Especially suitable

Opening principle



Series / Product

Inner height  $h_i$  [mm] +  
ø cable max.



Inner width  $B_i$  [mm]  
from - to



Outer height  $h_a$  [mm]



Outer width  $B_a$  [mm]  
from - to



Bending radius  $R$  [mm]  
from - to

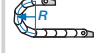

## twisterchain® new - Higher loads and speeds for circular/spiral movements

Snap-open along inner radius from both sides



Series / Product	Inner height $h_i$ [mm] + ø cable max.	Inner width $B_i$ [mm] from - to	Outer height $h_a$ [mm]	Outer width $B_a$ [mm] from - to	Bending radius $R$ [mm] from - to
TC32	32 ø 28	87,5 - 150	54	108,5 - 171	100 - 250
TC42	42 ø 38	87,5 - 200	64	110,5 - 223	100 - 250
TC56	56 ø 50	125 - 200	84	155,0 - 230	150 - 400

## twisterchain® classic - First generation for circular and spiral movements

Openable from both sides



Series / Product	Inner height $h_i$ [mm] + ø cable max.	Inner width $B_i$ [mm] from - to	Outer height $h_a$ [mm]	Outer width $B_a$ [mm] from - to	Bending radius $R$ [mm] from - to
2208	28 ø 25	52,5 - 112,5	42	80 - 140	55 - 150
2808	32 ø 29	50 - 150	54	81 - 181	100 - 250
3808	42 ø 39	50 - 200	64	85 - 235	100 - 250
4008	56 ø 53	50 - 200	84	93 - 243	150 - 400

## twisterband (7000° rotation) - Rotary movements in minimum space

Snap-open with film-hinge or to be opened with "easy"-principle

$R$  min.  $R$  max.



Series / Product	Inner height $h_i$ [mm] + ø cable max.	Inner width $B_i$ [mm] from - to	Outer height $h_a$ [mm]	Outer width $B_a$ [mm] from - to	Bending radius $R$ [mm] from - to
TB12.23.09	9 ø 7	23	42	80 - 140	24 35
TB20.44.12	12 ø 9	44	54	81 - 181	34 57
TB20.44.18	18 ø 14	44	64	85 - 235	34 57
TB30.75.22	22 ø 17	75	84	93 - 243	44 77

Pitch [mm]	Unsupported fill weight max [kg/m]		Unsupported length $FL_B$ max [m]	Long travel max [m]	Interior separation possibilities			ESD/ATEX igus.eu/used	Cleanroom	UL-V2 / V0	Low noise	Price index	Page
	180°	360°			Separators	Full-width shelves	Shelves						

Fill weight  
max [kg/m]  
180° 360°

### Higher speeds and loads

56	4	2	-	-	●	●	●	▲	○	▲	●	●●●	598
67	6	3,6	-	-	●	●	●	▲	○	▲	●	●●●	600
91	8	5	-	-	●	●	●	▲	○	▲	●	●●●	602

Fill weight  
max [kg/m]  
180° 360°

### For new designs we recommend twisterchain® new!

44	1,5	1	-	-	●	●	●	▲	○	▲	●	●●●	614
56	2	1	-	-	●	●	●	▲	○	▲	●	●●●	616
67	3	1,8	-	-	●	●	●	▲	○	▲	●	●●●	618
91	4	2,5	-	-	●	●	●	▲	○	▲	●	●●●	620

Fill weight  
max [kg/m]  
180° 360°

-	≈0,8	≈0,6	-	-	-	-	-	○	▲	○	●	●●●	626
-	≈1,25	≈1,0	-	-	-	-	-	○	▲	○	●	●●●	626
-	≈1,25	≈1,0	-	-	●	-	-	○	▲	○	●	●●●	626
-	≈1,7	≈1,3	-	-	●	-	-	○	▲	○	●	●●●	626

# Technical Details | chainfix strain relief

igus® strain relief

Product

ø [mm]  
from - to

## Clamps and stainless steel clamps - for maximum pull forces



CFX <sup>1)</sup> Single, double, triple standard clamps	6 - 42
CFXL <sup>1)</sup> Single, double, triple clamps with wide base for maximum pull forces	6 - 42
Saddle elements - bottom and stacker saddles	6 - 42
chainfix Multi-Clamps <sup>1)</sup>	6 -12

## Standard C-profiles and C-profiles for Heavy-Duty applications



Standard C-profiles Part No. <b>CF.92.42.</b> (to be integrated into KMA)	
C-profiles Part No. <b>CF.92.52.</b> with increased pull force (mounting in front of e-chain)	

## Tiewrap plates - for universal tiewrap, bolted or clip-on



<b>Option 1A:</b> Tiewrap plates as single part "Series 2000" + cable tiewraps	<b>max. 36</b>
<b>Option 1B:</b> Tiewrap plates as single part "Series 3000" + cable tiewraps	<b>max. 36</b>

## Tiewrap plates, with clip-on connection for the C-profile

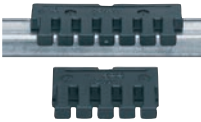

<b>Option 2:</b> Tiewrap plates with clip-on connection for the C-profile	
<b>Option 3:</b> Integrated strain relief for E2 e-tubes - Series R	
<b>Option 4:</b> Tiewrap plates for fixed crossbars	
<b>Option 5:</b> Tiewrap plates for opening crossbars	

## Clips - high pull forces, plug-in



<b>Option 1:</b> for all e-chains® with C-profiles and also suitable for assembly in the KMA mounting brackets	4 - 24
<b>Option 2:</b> Clip-on strain relief for opening crossbars	4 - 24

## Strain relief separators - with integrated teeth



Separator with integrated strain relief - easy strain relief with tiewrap	20 - 30
---	---------

## Nuggets - for top hat rail and C-profile



<b>Option 1:</b> completely simple and universal cable fixation, for diameter with Ø 20 mm and Ø 30 mm	≤ 30
<b>Option 2:</b> Fastening through clipping onto standard top hat rail	≤ 20

## Blocks - Special strain relief for hoses



Conventional igus® blocks - strain relief for hoses	4,3 - 14
CFB polymer strain relief connector system, many cables in a very confined space	

1) Standard material: galvanized steel. Also available as stainless steel-version (material stainless steel: 1.4301)

For Series easy chain®	For Series E2/000	For Series E2 e-tubes	For Series E4.1 / E4.1 light	For Series E4/light	For Series E6 / E6.1	Page
–	X	–	X	X	X	638
–	X	–	X	X	X	639
–	X	–	X	X	X	640
–	X	–	X	X	X	641
–	X	–	X	X	X	642
–	X	–	X	X	X	642
X	X	X	X	X	X	644
X	X	X	X	X	X	645
–	X	–	X	X	X	646
–	–	X	–	–	–	646
X	X	–	–	–	–	647
–	X	–	X	X	X	647
–	X	–	X	X	X	648
–	–	–	X	X	X	649
–	X	X	X	X	X	650
–	X	–	X	X	X	652
–	X	–	X	X	X	652
Please contact igus® for individual designing						653
						654

# Technical Details | Guide troughs | Long travel applications

## Legend of materials

- Aluminum, sea water-resistant
- Galvanized steel
- Stainless steel upon request
- ▲ Galvanized steel/polymer

Series / Product

Outer height  
through part (mm)

Series zipper

Series E2 mini

Series E2/000

1) Conditionally suitable in inner radii

Series E2 e-tubes



## Super-alu-trough - Basic version, for general use

### Basic version - igus® recommended standard trough system



970.30.SL   970.31.SL	77	15/R15	10/B15	-	-	-
970.30.SL   970.32.SL	77	-	-	1400 1/1450 1/1480 1/1500	-	-
971.30.SL   971.31.SL	87	-	-	2400 1/2450 1/2480 1/2500/255	R48	-
972.02.30.SL   972.02.31.SL	117	-	-	-	-	-
972.30.SL   972.31.SL	117	-	-	-	-	-
972.30.SL   972.32.SL	117	-	-	2600 1/2650 1/2680 1/2700	R58	-
973.30.SL   973.31.SL	144	-	-	3400 1/3450 1/3480 1/3500	R68	-
974.30.SL   974.31.SL	184	-	-	-	-	-
975.30.SL   975.31.SL	236	-	-	-	-	-

## Super-alu-trough - Heavy Duty version , for Heavy Duty use

### Heavy Duty version - For high load applications



971.30.SL   971.31.SL	87	-	-	2400 1/2450 1/2480 1/2500/255	R48	-
972.02.30.SL   972.02.31.SL	117	-	-	-	-	-
972.30.SL   972.31.SL	117	-	-	-	-	-
972.30.SL   972.32.SL	117	-	-	2600 1/2650 1/2680 1/2700	R58	-
973.30.SL   973.31.SL	144	-	-	3400 1/3450 1/3480 1/3500	R68	-
974.30.SL   974.31.SL	184	-	-	-	-	-
975.30.SL   975.31.SL	236	-	-	-	-	-

## Specialty: Steel guide trough, for harsh environments

### Steel Guide Trough - Very stable and rugged for heavy duty applications



92.30   92.31	70	-	-	2400 1/2450 1/2480 1/2500/255	-	-
95.30   95.31	100	-	-	2600 1/2650 1/2680 1/2700	R58	-
99.30   99.31	100	-	-	-	-	-
97.30   97.31	130	-	-	-	-	-
93.30   93.31	130	-	-	3400 1/3450 1/3480 1/3500	R68	-
94.30   94.31	170	-	-	-	-	-
94.14450.30   94.14450.31 New*	170	-	-	-	-	-
96.30   96.31	220	-	-	-	-	-
98.30   98.31	300	-	-	-	-	-
90.30   90.31	480	-	-	-	-	-

### Steel Guide Trough - One-piece, u-shaped, special solution for Series 10, B15, 15

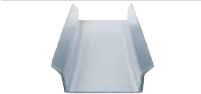

91.10 - 91.71	48	15/R15	10/B15	-	-	-
---------------	----	--------	--------	---	---	---

## guidefast - energy supply for crane girders













### Economical energy supply for crane girders and indoor cranes



GF91.30/31.025 New*	113	-	-	1400 1/1450 1/1480 1/1500	-	-
GF91.30/31.050 New*	113	-	-	1400 1/1450 1/1480 1/1500	-	-
GF92.30/31.05 New*	113	-	-	2400 1/2450 1/2480 1/2500/255	-	-
GF92.30/31.07 New*	113	-	-	2400 1/2450 1/2480 1/2500/255	-	-
GF92.30/31.10 New*	113	-	-	2400 1/2450 1/2480 1/2500/255	-	-
GF95.30/31.05 New*	113	-	-	2600 1/2650 1/2680 1/2700	-	-
GF95.30/31.07 New*	113	-	-	2600 1/2650 1/2680 1/2700	-	-
GF95.30/31.10 New*	113	-	-	2600 1/2650 1/2680 1/2700	-	-

\* in this catalog



System E4.1	System E4.1 light	System E4/light	System E6 please consult igus® for long travels	Material of side parts (see legend)	Price index 	
-	-	-	-	●		670
E4.21	-	-	-	●		672
-	-	-	E6.29/R6.29	●		674
E4.28/R4.28	-	-	E6.35	●		676
E4.32/H4.32/R4.32	E4.38L	-	E6.40/R6.40	●		678
-	-	-	-	●		680
E4.42/H4.42/R4.42	E4.48L	-	E6.52/R6.52	●		682
E4.56/H4.456/R4.56	-	14040/14140/18840/14240/14340	E6.62	●		684
E4.80/H4.80/R4.80	-	15050/15150/19850/15250/15350	E6.80	●		686
-	-	-	E6.29/R6.29	●		<a href="http://www.igus.eu/eu/salun">www.igus.eu/eu/salun</a>
E4.28/R4.28	-	-	E6.35	●		<a href="http://www.igus.eu/eu/salun">www.igus.eu/eu/salun</a>
E4.32/H4.32/R4.32	E4.38L	-	E6.40/R6.40	●		<a href="http://www.igus.eu/eu/salun">www.igus.eu/eu/salun</a>
-	-	-	-	●		<a href="http://www.igus.eu/eu/salun">www.igus.eu/eu/salun</a>
E4.42/H4.42/R4.42	E4.48L	-	E6.52/R6.52	●		<a href="http://www.igus.eu/eu/salun">www.igus.eu/eu/salun</a>
E4.56/H4.456/R4.56	-	14040/14140/18840/14240/14340	E6.62	●		<a href="http://www.igus.eu/eu/salun">www.igus.eu/eu/salun</a>
E4.80/H4.80/R4.80	-	15050/15150/19850/15250/15350	E6.80	●		<a href="http://www.igus.eu/eu/salun">www.igus.eu/eu/salun</a>
-	-	-	E6.29/R6.29	○ ■		694
-	-	-	-	○ ■		696
E4.28/R4.28	-	-	E6.35	○ ■		698
E4.32/H4.32/R4.32	E4.38L	-	E6.40/R6.40	○ ■		700
E4.42/H4.42/R4.42	E4.48L	-	E6.52/R6.52	○ ■		702
E4.56/H4.456/R4.56	-	14040/14140/14240/14340/18840	E6.62	○ ■		704
-	-	14550/14650/R19050	-	○ ■		706
E4.80/H4.80/R480	-	15050/15150/19850	E6.80	○ ■		708
E4.112/H4.112/R4.112	-	1640/1608	-	○ ■		710
-	-	800/840	-	○ ■		712
-	-	-	-	○ ■		693
-	-	-	-	○		720
-	-	-	-	○		720
-	-	-	-	○		720
-	-	-	-	○		720
-	-	-	-	○		720
-	-	-	-	○		720
-	-	-	-	○		720
-	-	-	-	○		720

**Legend of materials**

- Aluminum, sea water-resistant
- Galvanized steel
- Stainless steel upon request
- ▲ Galvanized steel/polymer

**Description**

**System P4 rol e-chain® - Energy efficient on long travels, high speeds**

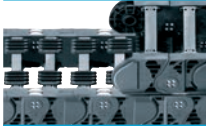

Reduce 57% energy consumption - for very long travels, high speeds, quiet. Safe, maintenance-free energy supply system on long travels up to 800 m and more for outdoor cranes or conveyor systems. With the right materials and clever design, the energy consumption can be drastically reduced.

**rol e-chain® - Rolling instead of gliding**



Reduction of driving power down to 25% to move the e-chain®. For very long travels with high fill weights. Due to the rolls, the friction coefficient of the system is very low - save money and energy.

**autoglide - long travels without guide troughs**



autoglide - special solutions for long travels without trough guides.

**guidelok horizontal - upper run support, unsupported up to 50 m**



Upper run guide for long travels, self-supporting in chip areas. Unsupported travels up to 50 m are possible. Chips cannot get stuck between upper and lower run. Modular system with few parts.

**guidelok slimline "F" - safe vertical guidance**



For e-chains® in high-speed rack feeders - up to 7 m/s and 10 m/s<sup>2</sup>. No swinging of the e-chain®, high reliability through lever mechanism and guiding rails. No bouncing of e-chains® in vertical applications with horizontal dynamics.

**lbt flizz® - enclosed plastic trough**



In its entirety, this system encompasses the igus® e-chain®, lbt flizz® guide trough and - as an option - fully configured igus® chainflex® cables. The lbt flizz® guide trough is a modular kit comprising of extruded guide profiles and a supporting frame with continuous tubes providing stabilization.

**micro flizz® - small e-chains® in aluminum profile**



Compact, cost-saving complete system for safe guidance of energy, data and air. Maintenance-free alternative for power bar.

**Optional: Support tray tool kit. For support of the lower run.**

Simple one-piece support trays according to your requirements and specification.

The complete range with order options ► from page 714



Typical industries and applications

Typical industries and applications	Travel max. [m]	Travel speed max. [m/s]	Inner heights [mm]	Price index	Page
<ul style="list-style-type: none"> <li>● Indoor-/Outdoor-applications</li> <li>● Cranes</li> <li>● Steelwork</li> <li>● Plant engineering</li> <li>● Construction machinery</li> <li>● Applications with very long travels and speeds</li> <li>● For harsh environments and high fill weights</li> </ul>	≈ 800	≈ 10	32 - 80 mm	● ● ●	726
					726
					726
					726
<ul style="list-style-type: none"> <li>● Outdoor applications</li> <li>● Cranes</li> <li>● Mining industry</li> <li>● Road building</li> <li>● Steel plants</li> <li>● All applications with long travels, rough environments and high fill weights</li> </ul>	≈ 400 - 800	≈ 6	32 - 80 mm	● ● ●	734
<ul style="list-style-type: none"> <li>● Indoor-/Outdoor-applications</li> <li>● Cranes</li> <li>● Storage and retrieval machines</li> <li>● Industrial trucks</li> </ul>	≈ 50	≈ 1,5	21 - 80 mm (4 options)	● ● ●	738
<ul style="list-style-type: none"> <li>● Machine tools</li> <li>● Applications in the chip area</li> <li>● Wherever a gliding application is not recommended</li> </ul>	≈ 50	≈ 2	56 mm	● ● ●	744
<ul style="list-style-type: none"> <li>● Automated storage/retrieval systems</li> <li>● Lifts</li> <li>● Revolving storage systems</li> <li>● Diagonal lifts</li> <li>● All vertical applications</li> </ul>	≈ 80	≈ 3	25 mm	● ● ●	746
<ul style="list-style-type: none"> <li>● Sewage treatment plants</li> <li>● Rainwater overflow basins</li> <li>● Galvanic equipment</li> <li>● Cranes</li> </ul>	≈ 120	≈ 8	24 mm <small>(In use of e-chain® Series 255)</small>	● ● ●	748
<ul style="list-style-type: none"> <li>● Indoor-cranes</li> <li>● Storage and retrieval machines</li> <li>● Industry gates</li> <li>● Control panels</li> <li>● Studio equipment (lighting)</li> </ul>	Available standard lengths: 2, 3, 6 m. Any number of troughs possible. Special lengths upon request!	≈ 6	11/13/20 mm <small>(Inner height of the applied e-chain®)</small>	● ● ●	752

**Modular system for projects - fast, all ex stock**

Special components, tested and approved in numerous projects, have now become available as a modular standard system ● Faster quotations ● Faster project planning ► from page 760



# Selection by inner heights



hi	Series	Product	Page
<b>5 - 10 mm</b>			
5	03	E2 micro	200
5	E03	easy chain®	142
7	04	E2 micro	202
7	E04	easy chain®	144
9	047	zipper	178
9,4	E045	easy chain®	146
9,4	Z045	easy chain®	146
10	E1.10	E1	166
10	05	E2 micro	206
10	E3.10	E3	488
<b>10,3 - 15 mm</b>			
10,3	045	E2 micro	204
10,3	B07	E2 micro	210
10,3	07	zipper	180
10,3	R07	zipper e-tube	182
10,5	06	E2 micro	208
10,7	E06	easy chain®	148
10,5	Z06	easy chain®	148
10,9	074	E2 micro	212
11,3	E065	easy chain®	150
11,3	Z065	easy chain®	150
14,3	B09	E2 micro	218
14,3	094	E2 micro	214
14,6	E08	easy chain®	152
14,7	Z08	easy chain®	152
15	08	E2 micro	216
15	E3.15	E3	490
15	09	zipper	184
15	R09	zipper e-tube	186
<b>17 - 23 mm</b>			
17	E1.17	E1	167
17	B15	E2 mini	234
17	B15i	E2 mini	234
17	15	zipper	188
17	R15	zipper e-tube	190
18	E1.18	E1	168
18	10	E2 mini	224
18	TE14	snapchain	172
18	TZ14	snapchain	172
19	E14	easy chain®	154
19	Z14	easy chain®	154
20	E1.20	E1	169
20	14	E2 mini	232
21	R117	E2 R100 e-tube	302
21	R118	E2 R100 e-tube	302
21	1400	E2/000	246
21	1450	E2/000	252
21	1500	E2/000	246
21	1480	E2/000 e-tube	252
21	E4.21	E4.1	370
22	E3.22	E3	492
23	11.031	E2 mini	226

hi	Series	Product	Page
<b>24 - 29 mm</b>			
24	255	E2/000	294
24,3	E200	easy chain®	156
24,3	E200.2	easy chain®	156
24,3	Z200	easy chain®	156
24,3	Z200.2	easy chain®	156
25	R48	E2 R e-tube	324
25	2400	E2/000	258
25	2450	E2/000	264
25	2500	E2/000	258
25	2480	E2/000 e-tube	264
28	11.080	E2 mini	228
28	E4.28	E4.1	374
28	R4.28	E4.1 e-tube	374
29	E6.29	E6	500
29	E61.29 <b>New*</b>	E6.1	536
28	R6.29	E6 e-tube	500
29	T3.29	T3 Band	480
<b>32 - 35 mm</b>			
32	B17	E2 mini	236
32	B17i	E2 mini	236
32	F17	E2 mini	238
32	E4.32	E4.1	380
32	H4.32	E4.1	380
32	R4.32	E4.1 e-tube	380
32	E16	easy chain®	158
32	Z16	easy chain®	158
32	P4.32	P4 rol e-chain®	716
32	2828R / R7728R	rol e-chain®	722
32	17	zipper	192
32	R17	zipper e-tube	194
35	R58	E2 R e-tube	330
35	2600	E2/000	270
35	2650	E2/000	276
35	2700	E2/000	270
35	2680	E2/000 e-tube	276
35	E6.35	E6	504
<b>36,5 - 48,5 mm</b>			
36,5	E26	easy chain®	160
36,5	Z26	easy chain®	160
37,1	E26.2	easy chain®	160
37,1	E26.3	easy chain®	160
37,1	Z26.2	easy chain®	160
37,1	Z26.3	easy chain®	160
38	E4.38L <b>New*</b>	E4.1 light	426
40	R157	E2 R100 e-tube	306
40	R158	E2 R100 e-tube	306
40	E6.40	E6	508
40	R6.40	E6 e-tube	508
41	11.1	E2 mini	230
41	11.2	E2 mini	230
42	E4.42	E4.1	386
42	H4.42	E4.1	386

\* in this catalog

hi	Series	Product	Page
42	R4.42	E4.1 e-tube	386
42	P4.42	P4 rol e-chain®	717
42	3838R / R7838R	rol e-chain®	722
42	RX32*	RX e-tube	346
45	R68	E2 R e-tube	336
45	3400	E2/000	282
45	3450	E2/000	288
45	3500	E2/000	282
45	3480	E2/000 e-tube	288
47	TE26	snapchain	173
47	TZ26	snapchain	173
48	E4.48L <b>New*</b>	E4.1 light	430
48,5	E300	easy chain®	162
48,5	E300.2	easy chain®	162
48,5	E300.3	easy chain®	162
48,5	Z300	easy chain®	162
48,5	Z300.2	easy chain®	162
48,5	Z300.3	easy chain®	162
<b>50 - 56 mm</b>			
50	R167	E2 R100 e-tube	314
50	R168	E2 R100 e-tube	314
52	E6.52	E6	514
52	E61.52 <b>New*</b>	E6.1	540
52	R6.52	E6 e-tube	514
52	RX40	RX e-tube	350
56	E4.56	E4.1	392
56	H4.56	E4.1	392
56	R4.56	E4.1 e-tube	392
56	14040	E4/light	440
56	14140	E4/light	440
56	18840	E4/light e-tube	440
56	P4.56	P4 rol e-chain®	718
56	4040R / R8840R	rol e-chain®	722
56	4040RHD	rol e-chain®	722
<b>62 - 86 mm</b>			
62	14240	E4/light	446
62	14340	E4/light	446
62	E6.62	E6	520
62	RX48	RX e-tube	354
70	14550	E4/light	452
70	14650	E4/light	452
70	19050	E4/light e-tube	452
73	RX56	RX e-tube	358
80	E4.80	E4.1	398
80	H4.80	E4.1	398
80	R4.80	E4.1 e-tube	398
80	15050	E4/light	458
80	15150	E4/light	458
80	19850	E4/light e-tube	458
80	E6.80	E6	528
80	E6.80L	E6	524
80	P4.80	P4 rol e-chain®	719
80	5050R / R9850R	rol e-chain®	722

hi	Series	Product	Page
80	5050RHD	rol e-chain®	722
86	15250	E4/light	464
86	15350	E4/light	464
<b>108 - 350 mm</b>			
108	1608	E4.1 e-tube	470
112	E4.112 <b>New*</b>	E4.1	404
112	H4.112 <b>New*</b>	E4.1	404
108	R4.112 <b>New*</b>	E4.1 e-tube	404
112	1640	E4/light	470
200	800	E4.1	410
204	840	E4.1	414
350	E4.350	E4.1	418
<b>3D e-chains®</b>			
12 <sup>1)</sup>	TRC/TRE/TRL.30	triflex® R	548/552/556
16	332.16	triflex®	586
16	333.16	triflex®	589
2x13	E332.25	easy triflex®	576
2x13	E333.25	easy triflex®	576
15 <sup>1)</sup>	TRC/TRE/TRL.40	triflex® R	548/552/556
32	332.32	triflex®	589
32	333.32	triflex®	586
2x17	E332.32	easy triflex®	576
2x17	E333.32	easy triflex®	578
22,5 <sup>1)</sup>	TRC/TRE/TRL.60	triflex® R	548/552/556
24,4 <sup>1)</sup>	TRLF.65 <b>New*</b>	triflex® R	560
28 <sup>1)</sup>	TRC/TRE/TRL.70	triflex® R	548/552/556
2x26	E332.50	easy triflex®	576
2x26	E333.50	easy triflex®	576
50	332.50	triflex®	586
50	333.50	triflex®	589
50	352.50	triflex®	586
50	353.50	triflex®	589
33 <sup>1)</sup>	TRC/TRE.85	triflex® R	548/552
32,8 <sup>1)</sup>	TRLF.85 <b>New*</b>	triflex® R	560
37,5 <sup>1)</sup>	TRC/TRE/TRL	triflex® R	548/552/556
37,5 <sup>1)</sup>	TRLF.100 <b>New*</b>	triflex® R	560
43,3 <sup>1)</sup>	TRC/TRE.125	triflex® R	548/552
75	332.75	triflex®	586
75	333.75	triflex®	589
2x38,5	E332.75	easy triflex®	576
2x38,5	E333.75	easy triflex®	578
<b>Circular and spiral movements</b>			
9	TB12.23.09	twisterband	611
12	TB20.44.12	twisterband	611
18	TB20.44.18	twisterband	611
28	2208	twisterchain® classic	614
22	TB30.75.22	twisterband	611
32	TC32	twisterchain®	598
32	2808	twisterchain® classic	616
42	TC42	twisterchain®	600
42	3808	twisterchain® classic	618
56	TC56	twisterchain®	602
56	4008	twisterchain® classic	620

\* in this catalog 1) maximal height

# Selection by product, series and page

Series	Product	Page	Series	Product	Page	Series	Product	Page
03	E2 micro	200	2480.AG	autoglide - 04	743	B15	E2 mini	234
04	E2 micro	202	2500	E2/000	258	B15i	E2 mini	234
045	E2 micro	204	2500.AG	autoglide - 04	743	B17	E2 mini	236
047	zipper	178	2600	E2/000	270	B17i	E2 mini	236
05	E2 micro	206	2600.AG	autoglide - 04	743	EA16	autoglide - 03	742
06	E2 micro	208	2650	E2/000	276	EA25	autoglide - 03	742
07	zipper	180	2650.AG	autoglide - 04	743	E03	easy chain®	142
074	E2 micro	212	2680	E2/000 e-tube	276	E04	easy chain®	144
08	E2 micro	216	2680.AG	autoglide - 04	743	E045	easy chain®	146
09	zipper	184	2700	E2/000	270	E06	easy chain®	148
094	E2 micro	214	2700.AG	autoglide - 04	743	E065	easy chain®	150
10	E2 mini	224	2808	twisterchain®	616	E08	easy chain®	152
11.031	E2 mini	226	2828R	rol e-chain®	736	E1.10	E1	166
11.080	E2 mini	228	3400	E2/000	282	E1.17	E1	167
11.1	E2 mini	230	3450	E2/000	288	E1.18	E1	168
11.2	E2 mini	230	3480	E2/000 e-tube	288	E1.20	E1	169
14	E2 mini	232	3500	E2/000	282	E14	easy chain®	154
15	zipper	188	3808	twisterchain®	618	E16	easy chain®	158
17	zipper	192	3838R	rol e-chain®	736	E26	easy chain®	160
255	E2/000	294	4008	twisterchain®	620	E26.2	easy chain®	160
332.16	triflex®	586	4040R	rol e-chain®	736	E26.3	easy chain®	160
332.32	triflex®	586	4040RHD	rol e-chain®	736	E200	easy chain®	156
332.50	triflex®	586	5050R	rol e-chain®	736	E200.2	easy chain®	156
332.75	triflex®	586	5050RHD	rol e-chain®	736	E3.10	E3	488
333.16	triflex®	589	7728R	rol e-chain®	736	E3.15	E3	490
333.32	triflex®	589	7838R	rol e-chain®	736	E3.22	E3	492
333.50	triflex®	589	8840R	rol e-chain®	736	E300	easy chain®	162
333.75	triflex®	589	9850R	rol e-chain®	736	E300.2	easy chain®	162
352.50	triflex®	586	14040	E4/light	440	E300.3	easy chain®	162
353.50	triflex®	589	14140	E4/light	440	E332.25	easy triflex®	576
800	E4.1	410	14240	E4/light	446	E332.32	easy triflex®	576
840	E4.1	414	14340	E4/light	446	E332.50	easy triflex®	576
1400	E2/000	246	14550	E4/light	452	E332.75	easy triflex®	576
1450	E2/000	252	14650	E4/light	452	E333.25	easy triflex®	579
1480	E2/000 e-tube	252	15050	E4/light	458	E333.32	easy triflex®	579
1500	E2/000	246	15150	E4/light	458	E333.50	easy triflex®	579
1608	E4/light e-tube	470	15250	E4/light	464	E333.75	easy triflex®	579
1640	E4/light	470	15350	E4/light	464	E4.21	E4.1	370
2208	twisterchain®	614	18840	E4/light e-tube	440	E4.28	E4.1	374
2400	E2/000	258	19050	E4/light e-tube	452	E4.32	E4.1	380
2400.AG	autoglide - 04	743	19850	E4/light e-tube	458	E4.38L <b>New*</b>	E4.1 light	426
2450	E2/000	264	autoglide		740	E4.42	E4.1	386
2450.AG	autoglide - 04	743	B07	E2 micro	210	E4.48L <b>New*</b>	E4.1 light	430
2480	E2/000 e-tube	264	B09	E2 micro	218	E4.56	E4.1	392

\* in this catalog



# Contents

## Design and calculation tools, applications, diagrams, harnessing, readychains®

### Introduction

Table of Contents   Designing with igus®	.....from page 84
the-chain   Designing with igus®	.....page 85
igus® Terms   Alphabetical Order	..... page 86
Calculation   e-chain®-Lengths and Camber	.....page 87

### Applications

Unsupported   Short Travels	.....from page 88
Unsupported   Noise-Optimized	.....page 91
Load Diagrams   $FL_G$   $FL_B$	.....from page 92
Gliding   Long Travels	.....from page 98
Application   Vertical Hanging	.....from page 104
Application   Vertical Standing	.....page 106
Application   Zig-Zag   liftband	.....page 107
Application   Side-Mounted	.....from page 108

Application   Rotary Motion	.....from page 110
Distribution Rules and Strain Relief	
Distribution rules   Cable, Hose Packages	..... from page 114
Strain Relief Elements   chainfix	..... from page 118

### Technical Data, Standards, Material Data

Technical Environment   Material	..... from page 120
Technical Environment   ESD & ATEX	..... from page 122
Technical Environment   Clean Room and ESD	..... page 124
Technical Environment   Dirty Environment	..... page 125
Material   Material Data and Colors	..... page 126
Material   Chemical Resistance	..... page 127
Certifying   Standards and Certificates	..... page 129
<b>readychains®</b>	
readychains®   Ready-Made e-chainsystems®	..... page 130

## easy chain®, System E1 and snapchain

<b>easy chain®</b>	..... 138	E08 / Z08	.....152	<b>E1</b>	..... 164	E1.20.015	.....169
E03	.....142	E14 / Z14	.....154	E1.10.013	.....166	<b>snapchain</b>	..... 170
E04	.....144	E200 / Z200	.....156	E1.17.021	.....167	TE14	.....172
E045 / Z045	.....146	E16 / Z16	.....158	E1.17.031	.....167	TZ14	.....172
E06 / Z06	.....148	E26 / Z26	.....160	E1.17.044	.....167	TE26	.....173
E065 / Z065	.....150	E300 / Z300	.....162	E1.18.015	.....168	TZ26	.....173

## zipper zip-open e-chains® and zip-open e-tubes

<b>zipper</b>	..... 174	R07 e-tube	.....182	15 e-chain®	..... 188	R17 e-tube	.....194
047 e-chain®	.....178	09 e-chain®	.....184	R15 e-tube	.....190		
07 e-chain®	.....180	R09 e-tube	.....186	17 e-chain®	.....192		

## System E2 micro, mini and E2/000

<b>micro</b>	..... 196	094	.....214	14	.....232	2450 / 2480	.....264
03	.....200	08	.....216	B15i / B15	.....234	2600 / 2700	.....270
04	.....202	B09	.....218	B17i / B17	.....236	2650 / 2680	.....276
045	.....204	<b>mini</b>	..... 220	F17	.....238	3400 / 3500	.....282
05	.....206	10	.....224	<b>E2/000</b>	.....240	3450 / 3480	.....288
06	.....208	11.031	.....226	1400 / 1500	.....246	255	.....294
B07	.....210	11.080	.....228	1450 / 1480	.....252		
074	.....212	11.1 / 11.2	.....230	2400 / 2500	.....258		

## e-tubes Series R100, Series R and System RX

<b>E2 e-tubes</b>	.....298	R167 / R168	.....314	R68	.....336	RX40	.....350
R117 / R118	.....302	R48	.....324	<b>RX e-tubes</b>	.....342	RX48	.....354
R157 / R158	.....306	R58	.....330	RX32	.....346	RX56	.....358



## System E4 - E4.1, E4.1 light, E4/light

E4.1 .....	362	E4.80/H4.80/R4.80 .....	398	E4.38L <b>New*</b> .....	426	15050/15150/19850 .....	458
E4.21 .....	370	E4.112/H4.112/R4.112 <b>New*</b> .....	404	E4.48L <b>New*</b> .....	430	15250/15350 .....	464
E4.28/R4.28 .....	374	800 .....	410	<b>E4/light</b> .....	434	1640/1608 .....	470
E4.32/H4.32/R4.32 .....	380	840 .....	414	14040/14140/18840 .....	440		
E4.42/H4.42/R4.42 .....	386	E4.350 .....	418	14240/14340 .....	446		
E4.56/H4.56/R4.56 .....	392	<b>E4.1 light</b> .....	422	14550/14650/19050 .....	452		

## System T3, E3, E6 and E6.1 - extremely low noise operation

<b>T3</b> .....	476	E3.22 .....	492	E6.52/R6.52 .....	514	E61.29 <b>New*</b> .....	536
T3.29 .....	480	<b>E6</b> .....	494	E6.62 .....	520	E61.52 <b>New*</b> .....	540
<b>E3</b> .....	484	E6.29/R6.29 .....	500	E6.80L .....	524		
E3.10 .....	488	E6.35 .....	504	E6.80 .....	528		
E3.15 .....	490	E6.40/R6.40 .....	508	<b>E6.1</b> .....	532		

## triflex® R, easy triflex®, triflex®, twisterchain®, twisterband

<b>triflex® R</b> .....	546	E333 .....	576	TC32 .....	598	4008 .....	620
TRC .....	548	<b>triflex®</b> .....	582	TC42 .....	600	<b>twisterband</b> .....	624
TRE .....	552	332 .....	586	TC56 .....	602	TB12 * .....	626
TRL .....	556	333 .....	589	<b>twisterchain® classic</b> .....	610	TB20 .....	626
TRLF <b>New*</b> .....	560	352 .....	586	2208 .....	614	TB30 .....	626
<b>easy triflex®</b> .....	572	353 .....	589	2808 .....	616		
E332 .....	576	<b>twisterchain® new</b> .....	594	3808 .....	618		

## igus® chainfix strain relief

CFX chainfix clamps - steel/stainless steel .....	638	Tiewrap plates for C-profile .....	646
CFXL chainfix clamps - steel/stainless steel .....	639	Clips .....	648
Saddle elements .....	640	Strain relief separators .....	650
Multi clamps .....	641	Nuggets .....	652
C-profiles standard and for heavy-duty applications .....	642	Blocks conventional .....	653
Universal tiewrap plates .....	644	CFB polymer strain relief connector system .....	654

## Guide troughs and special solutions for long travel applications

Aluminum SuperTrough ...	664	<b>Steel Guide Trough</b> .....	688	96.30   96.31 .....	708	guidelok horizontal .....	744
970.30.   970.31. ....	670	91.10 - 91.71. ....	692	98.30   98.31. ....	710	guidelok slimline F .....	746
970.30.   970.32. ....	672	92.30   92.31. ....	694	90.30   90.31. ....	712	lbt flizz® .....	748
971.30.   971.31. ....	674	95.30   95.31. ....	696	<b>Support Tray</b> .....	714	micro flizz® .....	752
972.02.30.   972.02.31. ....	676	99.30   99.31. ....	698	<b>guidefast</b> .....	720	igus® modular system	
972.30.   972.31. ....	678	97.30   97.31. ....	700	<b>Special solutions for</b>		for projects .....	760
972.30.   972.32. ....	680	93.30   93.31. ....	702	<b>long travels</b> .....	723		
973.30.   973.31. ....	682	94.30   94.31. ....	704	System P4 .....	726		
974.30.   974.31. ....	684	94.14450.30		rol e-chain® .....	734		
975.30.   975.31. ....	686	94.14450.31 <b>New*</b> .....	706	autoglide .....	738		

## Appendix

<b>Fax forms</b> .....	762	igus® addresses .....	768
------------------------	-----	-----------------------	-----

\* in this catalog

# Pictograms

## Accessibility of e-chains® and e-tubes



easy chain® principle: simply press cables in



One-piece design, can not be opened



RX e-tubes Snap-open along outer radius



triflex® R closed design



zipper principle: Zip-open along the outer radius



Snap-open along outer radius on left or right side



Can be opened from both sides



triflex® R, easy design for fast installation of cables and hoses



Snap-open along the inner radius



Snap-open along inner radius on left or right side



Can be opened from both sides and hinged open on one side



triflex® R, light version with "easy" design



Snap-open along the outer radius



Can be opened from one side



simple filling from 2 sides with easy principle



triflex® R, light version with snap lock mechanism

## Pictograms



Unsupported - short travels



Recommended Standard



igus® Calculation



Gliding - long travels



igus® information



Mounting brackets



Application Vertical hanging



igus® order examples



chainfix Strain relief



Application Vertical standing



igus® web [www.igus.eu](http://www.igus.eu)



Interior separation



Application Zig-Zag



Delivery time



Guide troughs



Application Side-mounted



Order key



NC-No camber version



Application Rotary motion



Temperature



Low-noise version



Continuously revolving e-chains®



Acceleration / Speed



Quick version



Application Horizontal and vertical



UL-Approval



ESD-Certificate



Application Nested



Weights



Other Clean room-Certificate



Application Side by side



Preferred Series



if produkt design award

## Price index



Low price category



Medium price category



Highest price category



## Quicklinks

Quicklinks for more information and additional features on each page. "Visit" directly your chosen product online - **for example** ► [www.igus.eu/ew/E4.56](http://www.igus.eu/ew/E4.56) and you'll find more details, 3D-CAD-files, DXF-files, PDF-downloads, application examples and many more for your chosen igus® product.

# Selection guide designing e-chains®

**1 Dimensioning e-chains®**  
Determine the size of the e-chain® based on the specified installation space of your machine and/or of the selected filling (such as the number of cables/outer diameter of cable).

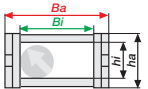

**2 Determine fill weight**  
Determine fill weight of (cables and/or media hoses) in [kg/m] using chainflex® quick selection or manufacturer specification.

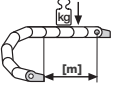

**3 Determine length of travel**  
Compare the fill weight calculated in (point 2) to the maximum fill weight of the selected e-chain® and check suitability for "unsupported application".

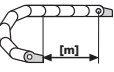

**4 Unsupported length**  
The maximum unsupported length initially depends on the fill weight and the e-chain® selected. At the same time, there are three different levels of unsupported length: ① **FL<sub>G</sub> - Recommended Range of Application** ② **FL<sub>B</sub> - Permitted Sag** ③ **Critical Sag: Should never be on operative installation!** Twice the value of the unsupported length determines the max. travel in the "unsupported" type of operation. For evaluation the weight of the cables to be carried must be known, then an exact evaluation can be made using a diagram on the introductory page of the selected product. You will find the values for **FL<sub>G</sub>** and **FL<sub>B</sub>** in table form on the following pages of this chapter and for each Series in the catalog. They are necessary for: ● Finding the fill weight and length of travel for the appropriate e-chain® ● Identifying the maximum load of the e-chain® used.

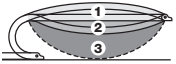
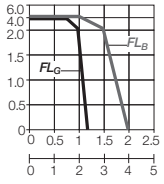



If there is suitability for "unsupported straight", then the selection follows the following criteria:

**5 Opening Principle**  
The quick finder gives an overview of the possibilities to fill the e-chain®.



**6 Bending Radius R**  
Determine the possible Bending Radius **R** [mm] of the e-chain® with respect to the cable diameter.



**7 Interior separation is possible with...**  
Separators      Full-width shelves      Shelves



The **price index** gives you the possibility of making price comparisons of similar sizes within the range.

**8 Low      Medium      Highest**



**9 Additional criteria -**  
For selection criteria such as pitch, permissible temperatures etc., please refer to our quick finder.

The following options are available if there is no possibility of self-supporting e-chain® application:

**A** You can choose the next and more stable e-chain®, that can be operated "unsupported".

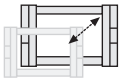

**OR**

**B** Option  
You can design your application to be "gliding".

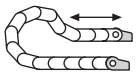

You can contact us directly or fax us your e-chain® requests! We will respond immediately!

e-chain® Part No: \_\_\_\_\_

Alternative e-chain®-dimensions:

hi: \_\_\_\_\_ Bi: \_\_\_\_\_ ha: \_\_\_\_\_ Ba: \_\_\_\_\_

Fill weight: \_\_\_\_\_ kg/m

Length of travel: \_\_\_\_\_ m

Your Phone: \_\_\_\_\_

Your Fax: \_\_\_\_\_

Phone (+49) 0 22 03 - 96 49-800

Fax (+49) 0 22 03 - 96 49-222

Internet ► [www.igus.eu/eu/finder](http://www.igus.eu/eu/finder)

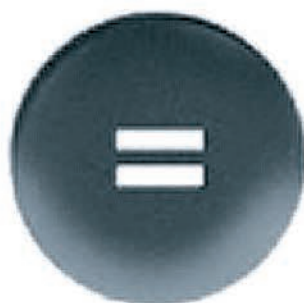
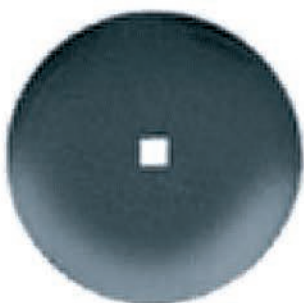

# designing with igus<sup>®</sup>

calculation tools, diagrams

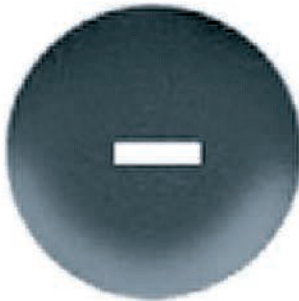

## Introduction

Table of Contents   Designing with igus® .....	from page 84
<b>the-chain</b>   Designing with igus® .....	page 85
igus® Terms   <b>Alphabetical Order</b> .....	page 86
Calculation   <b>e-chain®-Lengths and Camber</b> .....	page 87

## Applications

Unsupported   <b>Short Travels</b> .....	from page 88
Unsupported   <b>Noise-Optimized</b> .....	page 91
Load Diagrams   <b>Unsupported Straight <math>FL_G</math></b>   <b>Unsupported Sag <math>FL_B</math></b> .....	from page 92
Gliding   <b>Long Travels</b> .....	from page 98
Application   <b>Vertical Hanging</b> .....	from page 104
Application   <b>Vertical Standing</b> .....	page 106
Application   <b>Zig-Zag</b>   <b>liftband</b> .....	page 107
Application   <b>Side-Mounted</b> .....	from page 108
Application   <b>Rotary Motion</b> .....	from page 110

## Distribution Rules and Strain Relief

Distribution rules   <b>Cable and Hose Packages</b> .....	from page 114
Strain Relief Elements   <b>chainfix</b> .....	from page 118

## Technical Data, Standards, Material Data

Technical Environment   <b>Material</b> .....	from page 120
Technical Environment   <b>ESD &amp; ATEX</b> .....	from page 122
Technical Environment   <b>Clean Room and ESD</b> .....	page 124
Technical Environment   <b>Dirty Environment</b> .....	page 125
Material   <b>Material Data and Colors</b> .....	page 126
Material   <b>Chemical Resistance</b> .....	page 127
Certifying   <b>Standards and Certificates</b> .....	page 128

## readychains®

readychains®   <b>Ready-Made e-chainsystems®</b> .....	from page 130
--	---------------

## An all-in-one energy supply system - the-chain

There are many options to supply your equipment and systems with energy and data. But there is hardly a solution as universal and durable as the e-chainsystem®. Whether you have a circular motion, a continuously circulating motion, a suspended or upright application, a long travel distance, high loads or a motion in space - igus® plastic e-chains® will help you solve nearly any type of energy supply problem, quickly, confidently and with ease. Whether you wish to reliably guide many large hoses for any type of media, sensitive fiber optic signals over long distances, disruption-free data at torsional movements, or only air at high accelerations, igus® can supply you with the matching energy supply system in addition to the optimally matched chainflex® cables.

By tapping into the expansive igus® construction kit (more than 90.000 e-chain® versions and 1.030 chainflex® cables), you will generally always find the solution to match your needs and application: from the individual component to the completed assembly at your facility. We have developed a new online tool to help you find these resources with greater ease ► [www.igus.eu/eu/the-chain](http://www.igus.eu/eu/the-chain). Should you have trouble finding exactly the product you need, our developers are of course at your disposal to help you design the-chain.



## Laboratory and practical experience

Our calculations and analyses are based on the result of ongoing practical tests in our Technical Center and our experience with gliding applications. The focal points of our tests are push-pull forces, friction values and abrasion under widely varying conditions and speeds, as well as factors such as dirt, weathering or impact and bumps. We test all system components such as cables, hoses, strain relief and other accessories, in addition to the e-chains® or e-tubes and Guide Troughs.



More than 1.750 m<sup>2</sup> testlab for e-chains® and chainflex®-cables. Up to 15.000 tests per year

## Application-Icons

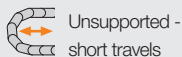

Unsupported - short travels



Gliding - long travels



Application Vertical hanging



Application Vertical standing



Application Zig-Zag



Application Side-mounted



Application Rotary motion



Continuously revolving e-chains®



Application Horizontal and vertical



Application Nested



Application Side by side



Application Combined motions

## Short cuts and description

$\alpha$	= The rotation angle of the rotating machine element	[ ° ]
$\Delta M$	= Deviation of the center point	[mm]
$a$	= Acceleration	[m/s <sup>2</sup> ]
$AR$	= Outer radius, e-chain®	[mm]
$Ba$	= Outer e-chain® width	[mm]
$Bi$	= Inner e-chain® width	[mm]
$B_{Ra}$	= Guide trough outer width	[mm]
$B_{Ri}$	= Guide trough inner width	[mm]
$D$	= Over length e-chain® radius in final position	[mm]
$D_2$	= Over length for long travels gliding	[mm]
$FL_B$	= Unsupported length with sag	[m]
$FL_G$	= Unsupported straight length	[m]
$FL_U$	= Unsupported lower run	[m]
$FZ_{max}$	= Maximum additional load	[kg/m]
$H$	= Nominal clearance height	[mm]
$H_2$	= Installation height with lowered mounting	[mm]
$ha$	= Outer e-chain® height	[mm]
$H_F$	= Required clearance height	[mm]
$hi$	= Inner e-chain® height	[mm]
$H_{Ra}$	= Outer trough height	[mm]
$H_{Ri}$	= Inner trough height	[mm]
$IR$	= Inner radius, e-chain® (twisterchain®)	[mm]
$K$	= Add-on for bending radius (K is taken from the data tables of the individual Series)	[mm]
$K_2$	= Further add-on if the mounting bracket location is set lower (for long travels)	[mm]
$L_K$	= e-chain® length	[mm]
$n$	= Number of links	[1]
$n_{Mon}$	= Number of installation sets (left/right)	[1]
$n_{Ri}$	= Number of trough-sets (left/right)	[1]
$R$	= Bending radius	[mm]
$RBR$	= Reverse bending radius	[mm]
$S$	= Length of travel	[mm]
$S/2$	= Half length of travel	[mm]
$T$	= Pitch	[mm]
$v$	= Speed (travel)	[m/s]
$X_1$	= Inner machine-construction space (twisterchain®)	[mm]
$X_2$	= Outer radius e-chain®, including clearance (twisterchain®)	[mm]

## igus® Formula

$SFL_B = 2 \times FL_B$	Calculation of maximum travel length, unsupported with sag
$SFL_G = 2 \times FL_G$	Calculation of maximum travel length, unsupported straight
$B_{Ri} \geq Ba + 5$	Calculation of the minimum guide trough width
$H_{Ri} \geq 2 \times ha$	Calculation of the minimum guide trough height
$K = \pi \times R + (2 \times T)$	Add-on for bending radius
$L_K = S/2 + \Delta M + K$	Calculation of e-chain® lengths, fixed end is outside the center of travel ( $FL_G$ , $FL_B$ and $\Delta M$ )
$L_K = S/2 + K$	Calculation of e-chain® lengths For all types of applications, fixed end in the center of travel, except rotary movements and most long travels
$L_K = S/2 + K_2$	Calculation of e-chain® lengths for long travels, fixed end in the center of travel [m]



# Calculation | e-chain® -Lengths and Camber

## Calculation of e-chain® lengths

If the fixed end of the e-chain® is located in the center of the travel, the e-chain® length  $L_K$  is calculated by using half the length of travel and adding the value  $K$  for the curved length. (You can obtain the value  $K$  from the tables in the catalog.) Placing the Fixed End in the center of the travel is the **most cost-effective solution** because it requires the shortest e-chain®, cables and hoses.

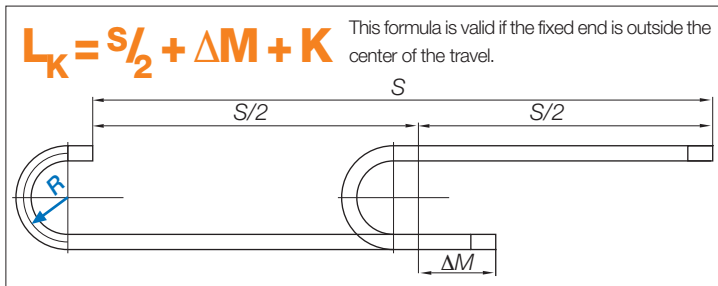
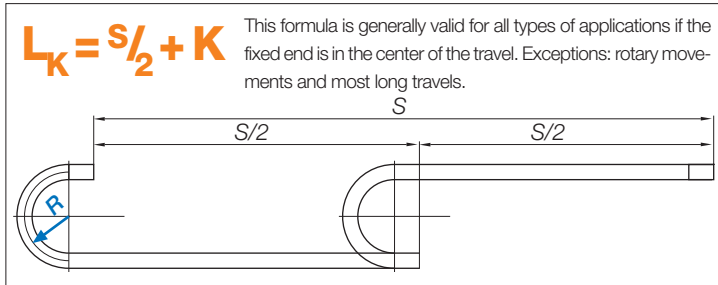

## Camber

Camber is the curve of the upper run along its unsupported length. All igus® e-chains® are manufactured with camber, special "no camber" e-chains® are available on request. The camber allows for longer unsupported lengths and increases service life and operating safety. In the Installation Dimensions section of each respective e-chain® description, you will find the measurement  $H_F$ , which specifies the necessary clearance height, taking the camber into account. Upon request, we can deliver e-chains® without camber for restricted space applications - however, these "no camber" e-chains® do not have the same load-bearing capacity. Please consult igus®.

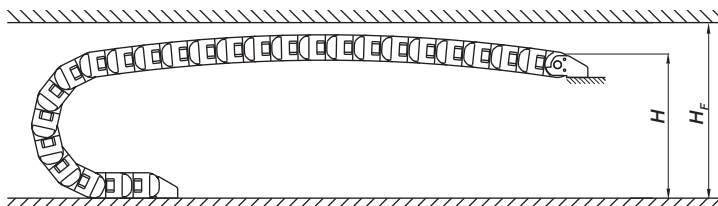

Principle of camber for igus® e-chains®  $H_F$  = required installation height



The fixed end in the center of the travel is the most favorable solution

$L_K$  = e-chain® length  
 $S$  = Length of travel  
 $R$  = Bending radius

$\Delta M$  = Deviation from the center point

$K = \pi \times R + (2 \times T)$

Add-on for bending radius ( $K$  is taken from the data tables of the individual igus® Series)



"No Camber" - Special "NC" e-chains® with no camber also available. Please consult igus®.

$H$  = Nominal clearance height

$H_F$  = Required clearance height

Necessary clearance height - depends on the camber of the e-chain®. Find values for the necessary clearance height  $H_F$  on each product page.

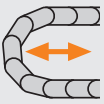

# Unsupported | Short Travels



The  $FL_G$  type of installation always generates the longest service life and can be operated with the max. values for speed and acceleration.



Example for unsupported straight  $FL_G$

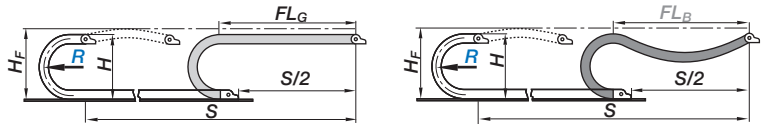

## Unsupported applications

If the upper run of the e-chain® operates without touching the lower run over the entire travel, it is called an "unsupported" application. The distance between moving end and the beginning of the radius curve of the e-chain® is called the "**unsupported length**." The "unsupported" application is the most common. igus® e-chains® are very well suited for high dynamics and long service life. The maximum unsupported length is dependent upon the fill weight and the type of e-chain® or e-tube. As a result, we differentiate among three types of unsupported length:

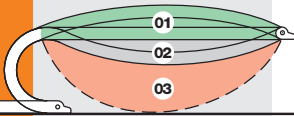

- 01) Unsupported with straight upper run  $FL_G$
- 02) Unsupported with permitted sag  $FL_B$
- 03) Critical sag

### 01) Unsupported with straight upper run $FL_G$

The " $FL_G$ " e-chain® applies when the upper run either has camber, is straight, or has a maximum of 10-50 mm sag, depending on the size of the e-chain®. The " $FL_G$ " type of installation is always preferred. The e-chain® runs quietly and is not exposed to any additional vibration.

### 02) Unsupported with permitted sag $FL_B$

The " $FL_B$ " e-chain® applies when the sag amounts to more than 10-50 mm, depending on the e-chain® size, and less than a defined maximum sag. This maximum sag is dependent on the type of e-chain®. The " $FL_B$ " application is technically permissible in many cases. It becomes problematic if the acceleration and the travel frequency are high.

### 03) "Critical sag"

If the sag is greater than permissible for " $FL_B$ ", then we refer to it as "critical sag." An installation with critical sag must be avoided or reserved for extreme circumstances. An e-chain® should never be installed with critical sag. There are applications which, after a very long period of use, reach the stage of "critical sag." The e-chain® or e-tube should be replaced at that time. Please contact us if your application reaches critical sag!

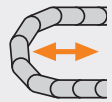

For every igus® e-chain® or e-tube, you will find the values for " $FL_G$ " and " $FL_B$ " in two locations: On the following pages in this chapter as an overview and within every individual series' chapter. These values are essential for:

- Finding a suitable e-chain® for your fill weight and travel distance
- Identifying the maximum load for the selected e-chain®.



Example of unsupported permissible,  $FL_B$

### What to do if the unsupported length is insufficient

If your application, **fill weight** and **travel** fall outside the "unsupported length" parameters of the desired e-chain®, you have the following options:

- Select a stronger igus® e-chain®
- Support the e-chain® in the unsupported area (this possibility has restrictions for acceleration, speed and noise as a consequence - three fundamental examples are detailed to below - please consult igus® if you are considering this possibility - we will gladly provide you with a detailed proposal)
- Use a "multiband" e-chain® or "nest" two e-chains® inside one another (please consult igus® regarding these options)
- Design the travel distance as a "gliding application".

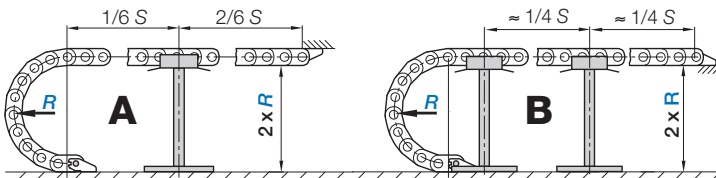

Support of the " $FL_G$ " area. A) The overall "straight, unsupported travel" can be increased here by a maximum of 50% of the  $FL_G$  and in case of option B) by a maximum of 100%

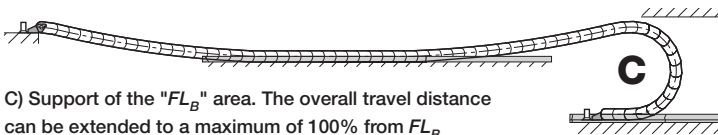

C) Support of the " $FL_B$ " area. The overall travel distance can be extended to a maximum of 100% from  $FL_B$

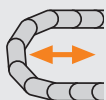

We recommend pivoting mounting brackets as standard! We recommend locking mounting brackets as standard if high speeds > 20 m/s or accelerations > 20 m/s<sup>2</sup>



**Standard values of max. speed and acceleration:**

	Unsupported $FL_G$	$FL_B$
$v$ max. [m/s]	20	3
$v$ peak [m/s]	50	–
$a$ max. [m/s <sup>2</sup> ]	200	6
$a$ peak [m/s <sup>2</sup> ]	784	–

Standard value of  $FL_G$  service life: 10 million cycles

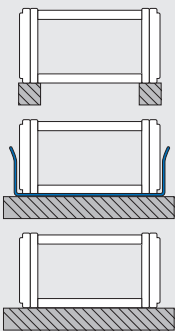

Different surfaces + guide troughs are possible

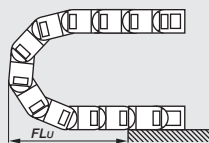

$FL_U$  = Unsupported lower run

## Unsupported | Short Travels

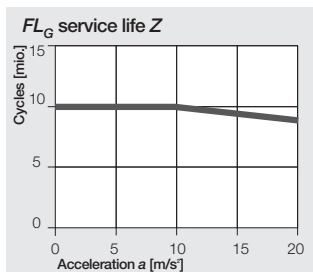

Standard values on service life for  $FL_G$ , dependent on acceleration

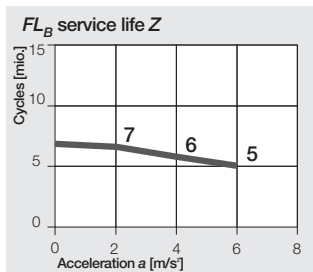

Standard values on service life for  $FL_B$ , dependent on acceleration

### Mounting surfaces

Unsupported e-chains® normally require some type of surface on which the lower portion of the e-chain® runs. A wide range of configurations is available, as the drawings on the right demonstrate. Many material options are feasible: Metals, polymers, stone, wood, concrete, glass, etc. We also have solutions to minimize the noise generated by the e-chain® lower portion. Please consult igus®. When selecting the running surface, be sure dirt and debris cannot collect in the e-chain® path.

### Mounting brackets

**We recommend pivoting mounting brackets as standard for unsupported applications.**

Pivoting mounting brackets compensate for the camber, can be installed more easily and decrease the load on the first e-chain® link in operation. Exception: If the acceleration is greater than 20 m/s<sup>2</sup> or if the height is limited to the  $H_F$  measurement, locking mounting brackets keep the e-chain® under the  $H_F$  measurement.

### Unsupported lower run

e-chains® without support along the lower run have restricted use. The value  $FL_U$  usually must be determined in a test by igus®. The maximum permissible amount of the projection depends on the fill weight, the selected e-chain®, the dynamics, and other factors, because the various combinations of these parameters can produce very different results. If the lower run of the e-chain® cannot be supported over the whole travel, please consult igus®.

### Speed, acceleration and service life

For unsupported applications, the acceleration  $a$ , is the critical parameter. High acceleration can cause the e-chain® to vibrate and reduce its service life. This is a particular danger if the e-chain® already has a sag greater than the  $FL_G$  value. Max. values for acceleration, speed and service life are achieved only with e-chains® incorporating the  $FL_G$  design.  $FL_G$  designed e-chainsystems® can sustain very high loads. To date, a **peak acceleration of 784 m/s<sup>2</sup>** has been achieved during continuous use. Through ongoing testing in the igus® laboratory and from practical experience, standard values for service life have been formulated. Our tests confirm that these standard values apply to all igus® e-chains® and e-tubes. It is crucial to determine whether the application will be designed as unsupported straight  $FL_G$  or unsupported, with sag  $FL_B$ .

# Unsupported | Noise-Optimized

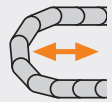

## Minimize noise levels with igus® e-chainsystems®

The igus® program offers you optimal noise-reduction e-chains®. The table below briefly illustrates the differences in noise level among various e-chains®. In addition to the e-chain®, the running surface, the dynamics and the cable and hose package play a role in overall noise generation. Have our specialists design the quietest e-chainsystem® for your application, for example:

### System T3 ≤ 33 dB(A)

Optimal smoothness of motion was the prime development goal, as well as making it an economic solution. The igus® T3 e-chain® is very flexible and runs -due to the special geometry- very smooth. A measurement indicates a value of ≤ 33 dB(A) at 1 m/s and with an unsupported length with Series **T3.29.050.038.0**, and all this with a sound pressure level generated by external noise.

### System E3 ≤ 38 dB(A)

Long-term tests in the igus® acoustic laboratory showed reductions of 19-20 db(A) compared with standard e-chains®, measured at a speed of 1.8 m/s and an acceleration of 3 m/s². Figure determined in the igus® laboratory in accordance with DIN 45635, taking into consideration background noises, for the **Series E3.22.060.044.0**.

### System E6 ≤ 46 dB(A)

A measurement conducted by the Rhineland Technical Inspection Authority (TÜV Rheinland) in May 2002 indicates a value of ≤ 46 dB(A) at 2 m/s and with an unsupported length of 1.5 m with **Series E6.52.10.100.0**, and all this with at least 10 dB(A) sound pressure level generated by external noise. The System E6 runs very smoothly due to their small pitch.

### System E4 ≤ 46 dB(A)

A measurement by the Rhineland Technical Inspection Authority (TÜV Rheinland) for **System E4/101, Series 221.10.200.0** indicates a value of 46 dB(A) at 1,5 m/s with an unsupported length. Due to the special rubber pads (in red pictured) of the System E4, the noise will be extremely damped. The standard version of E4 is already very reduced in noise due to their special designed stop dog.

## Selected noise tests - external noise corrected measurement values

e-chain® Series	System	Averaging of the corrected sound pressure levels	Test method
igus® Series T3.29	T3	≈ 33 dB(A)	unsupported 1,0 m/s
igus® Series E3.22	E3	≈ 38 dB(A)	unsupported 1,8 m/s
igus® Series E6.52	E6	≈ 46 dB(A)	unsupported 2,0 m/s
igus® Serie 221	E4/00	≈ 46 dB(A)	unsupported 1,5 m/s
igus® Series ES4.42	E4.1	≈ 46 dB(A)	unsupported 1,0 m/s
igus® Series E4.42	E4.1	≈ 50 dB(A)	unsupported 1,0 m/s
igus® Series 255	E2 medium	≈ 53 dB(A)	unsupported 1,5 m/s
igus® Series e-band	e-band	≈ 59 dB(A)	unsupported 1,5 m/s
Chain 1 Third Party Product		≈ 77 dB(A)	unsupported 2,0 m/s
Chain 2 Third Party Product		≈ 68 dB(A)	unsupported 2,0 m/s
Chain 3 Third Party Product		≈ 73 dB(A)	unsupported 2,0 m/s

Source: TÜV Rheinland, except Series E3.22 - Source: igus® laboratory



A reduction of 3 dB(A) sounds like a 50% reduction in the noise level to the human ear



We have received an official certificate from the Rhineland Technical Inspection Authority (TÜV Rheinland Berlin-Brandenburg) and we are able to provide you with a copy on request

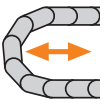

# Unsupported | Straight $FL_G$ | Fill weights up to 1,5 kg/m

## Load diagram unsupported

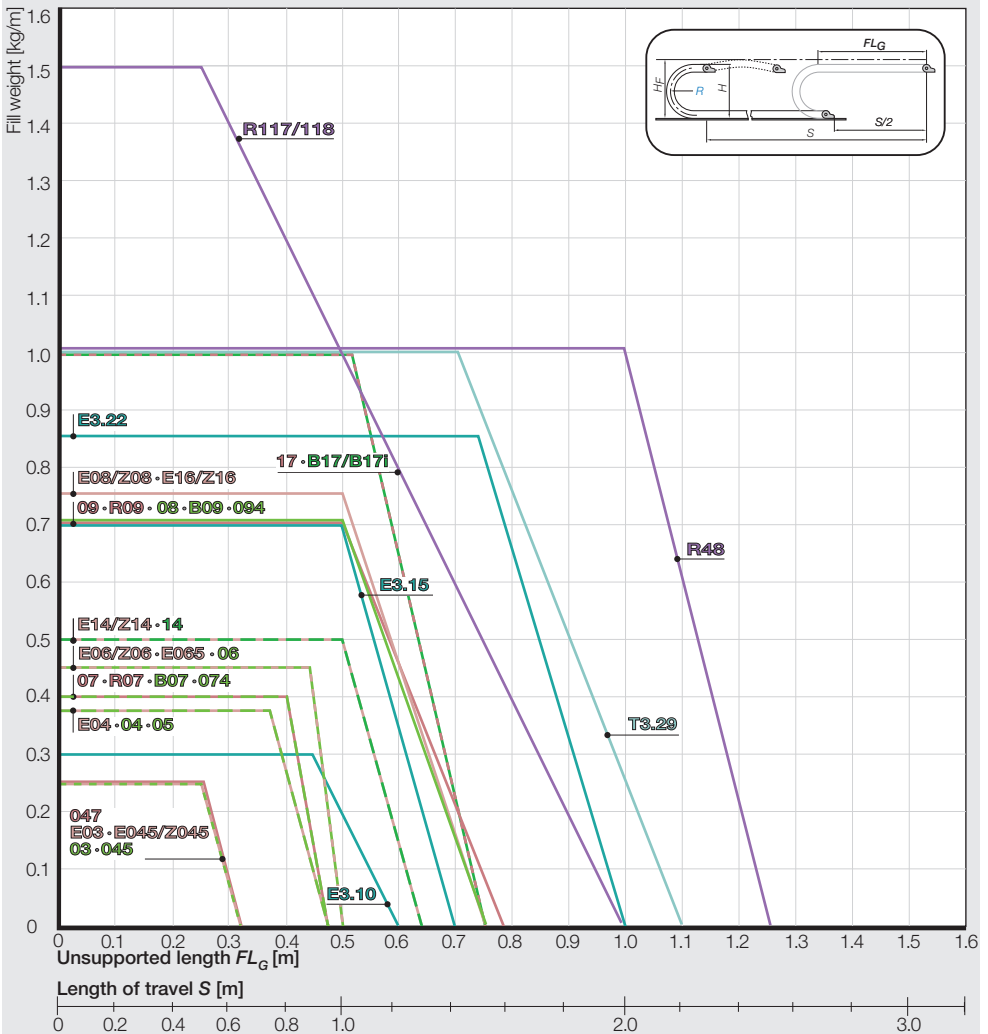

### Important information

- Fill weight - Weight of all cables and hoses, including contents (for media hoses) within the e-chain®, typically given [kg/m]
- $FL_G$  - unsupported e-chain® with straight upper run
- $FL_B$  - unsupported e-chain® with permitted sag
- To the right of the  $FL_B$  graph of the diagram, the application is shown in "critical sag", which must be avoided!

These values are essential for: ● Finding a suitable e-chain® for your fill weight and travel distance ● Identifying the max. load for the selected e-chain®. If you cannot meet your application demands using these parameters, keep in mind these specifications are conservative maximum values. In individual cases, they can be exceeded by up to 30%. Special solutions are also possible. Please consult igus®

# Unsupported | Sag $FL_B$ | Fill weights up to 1,5 kg/m

Load diagram unsupported

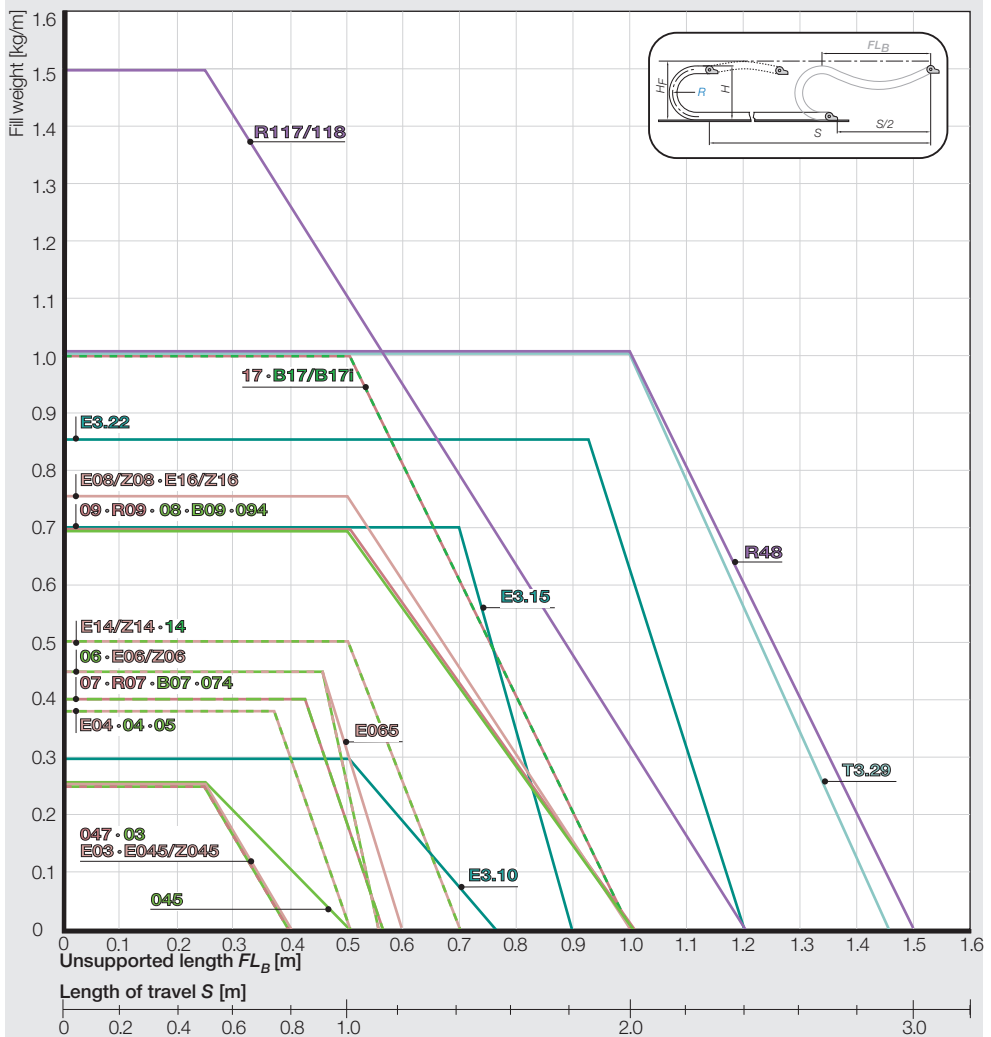
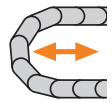

## The maximum travel -

always amounts to  $2 \times FL_G$  or  $FL_B$  if the fixed end is in the center of the travel. In this case, the following applies:

$$e\text{-chain}^\circ \text{ length: } L_K = S/2 + K$$

$S$  = Length of travel

$R$  = Bending radius

$H$  = Nominal clearance height

$H_r$  = Required clearance height

$K = \pi \times R + (2 \times T)$  Add-on for bending radius

## Series diagrams

You will find both diagrams for each series listed individually in the catalog

- triflex® ▶ page 582
- easy chain® ▶ page 138
- System E3 ▶ page 484
- System T3 ▶ page 476
- zipper ▶ page 174
- E2 micro ▶ page 196
- E2 mini ▶ page 220

Find the values for " $FL_G$ " and " $FL_B$ " also ▶ in every individual Series chapter!

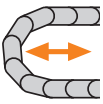

# Unsupported | Straight $FL_G$ | Fill weights up to 9,0 kg/m

## Load diagram unsupported

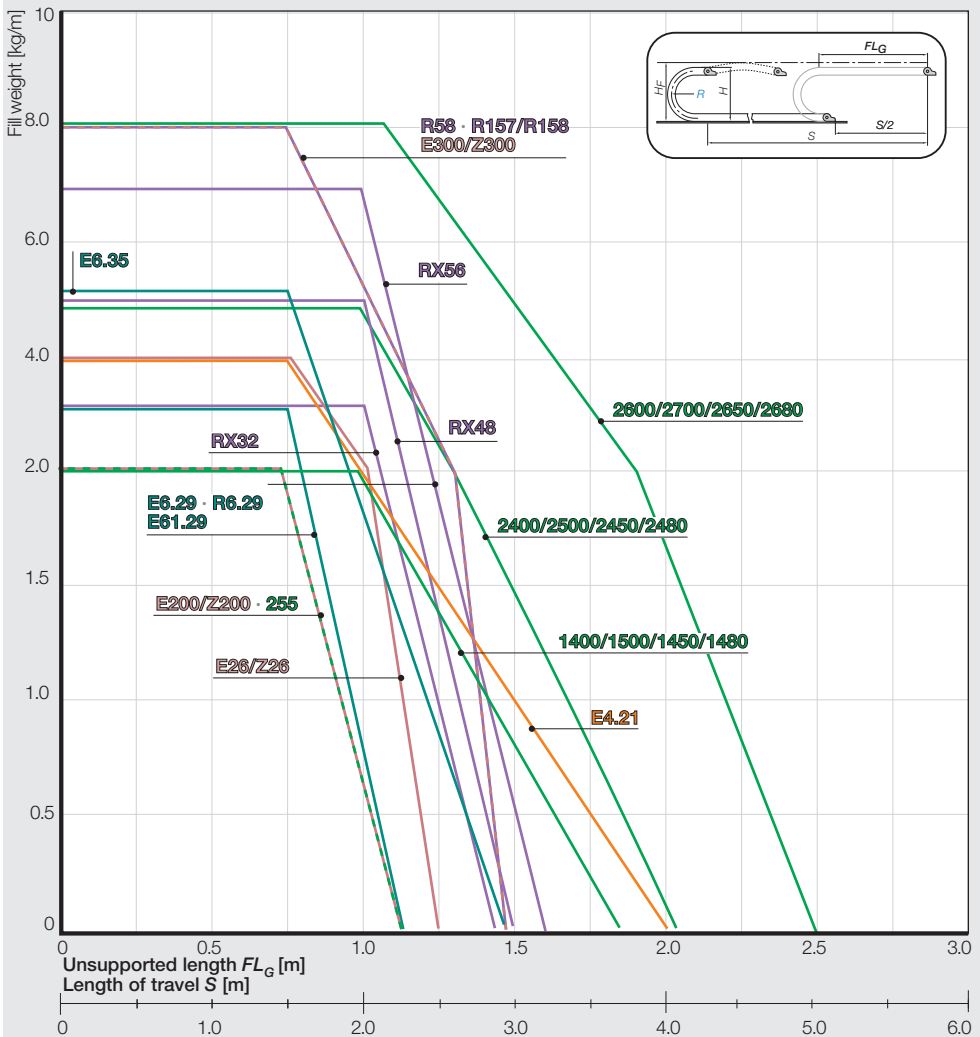

### Important information

- Fill weight - Weight of all cables and hoses, including contents (for media hoses) within the e-chain®, typically given [kg/m]
- $FL_G$  - unsupported e-chain® with straight upper run
- $FL_B$  - unsupported e-chain® with permitted sag
- To the right of the  $FL_B$  graph of the diagram, the application is shown in "critical sag", which must be avoided!

These values are essential for: ● Finding a suitable e-chain® for your fill weight and travel distance ● Identifying the max. load for the selected e-chain®. If you cannot meet your application demands using these parameters, keep in mind these specifications are conservative maximum values. In individual cases, they can be exceeded by up to 30%. Special solutions are also possible. Please consult igus®



# Unsupported | Sag $FL_B$ | Fill weights up to 9,0 kg/m

## Load diagram unsupported

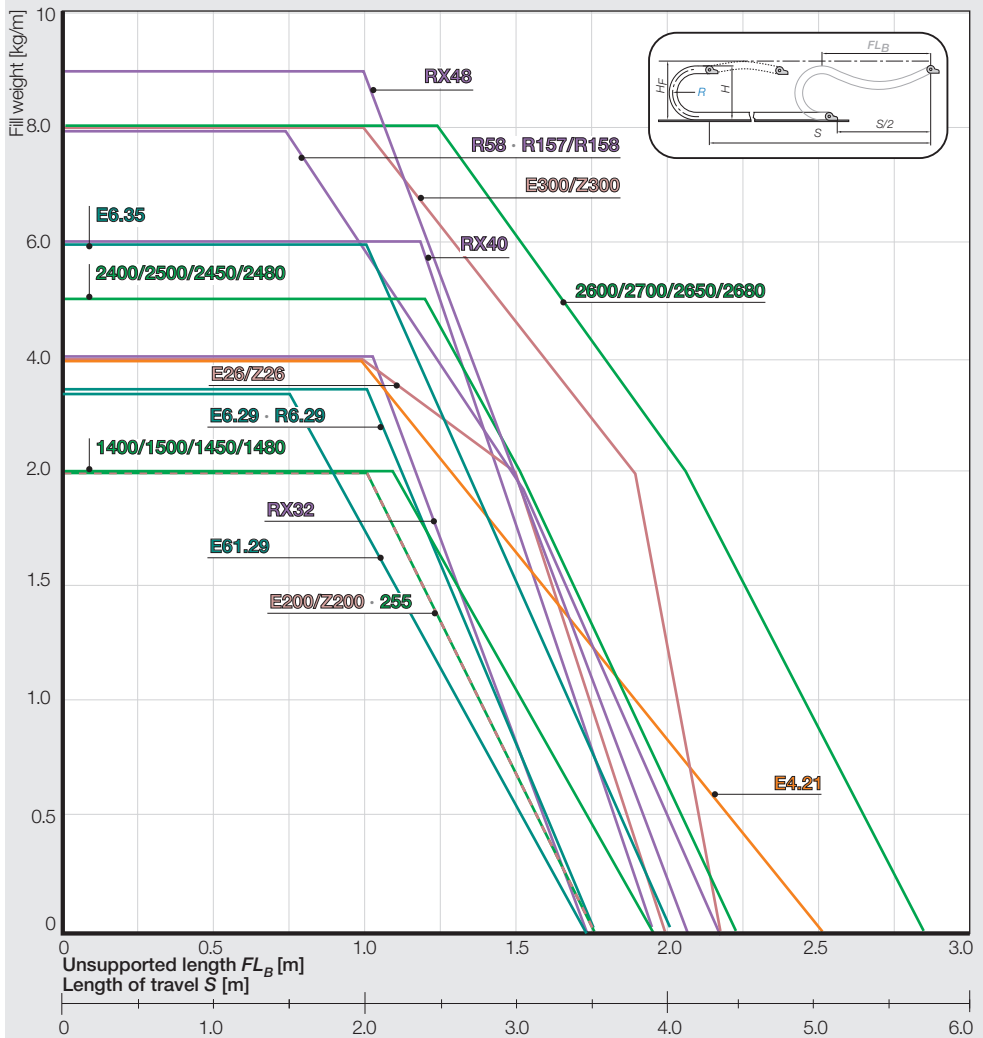
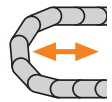

### The maximum travel -

always amounts to  $2 \times FL_G$  or  $FL_B$  if the fixed end is in the center of the travel. In this case, the following applies:

**e-chain® length:**  $L_K = S/2 + K$

$S$  = Length of travel

$R$  = Bending radius

$H$  = Nominal clearance height

$H_e$  = Required clearance height

$K = \pi \times R + (2 \times T)$  Add-on for bending radius

### Series diagrams

You will find both diagrams for each series listed individually in the catalog

- easy chain® ▶ page 138
- E2/000 ▶ page 240
- E2 /RX e-tubes ▶ page 342
- E4.1 ▶ page 362
- E6 ▶ page 494
- E6.1 ▶ page 532 Values upon request!

Find the values for " $FL_G$ " and " $FL_B$ " also ▶ in every individual Series chapter!

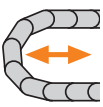

# Unsupported | Straight $FL_G$ | Fill weights up to 90 kg/m

## Load diagram unsupported

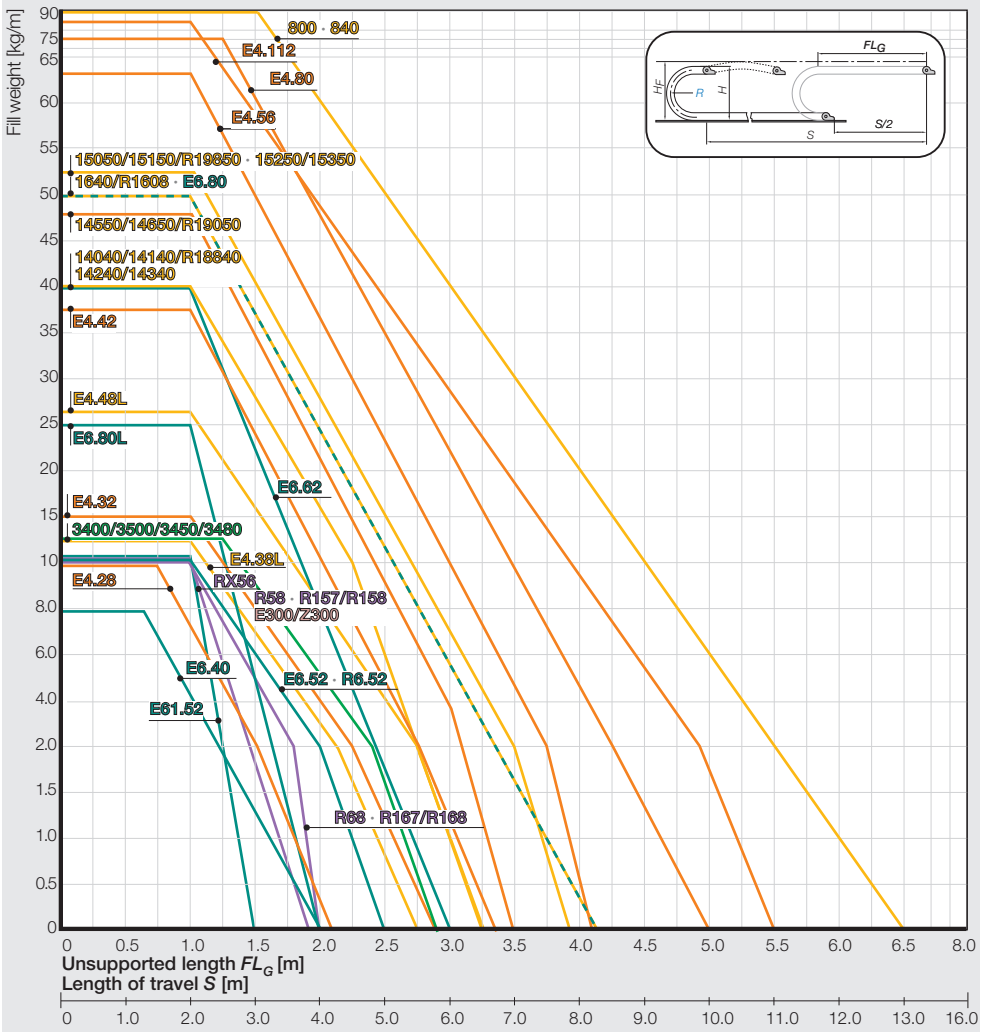

### Important information

- Fill weight - Weight of all cables and hoses, including contents (for media hoses) within the e-chain®, typically given [kg/m]
- $FL_G$  - unsupported e-chain® with straight upper run
- $FL_B$  - unsupported e-chain® with permitted sag
- To the right of the  $FL_B$  graph of the diagram, the application is shown in "critical sag", which must be avoided!

These values are essential for: ● Finding a suitable e-chain® for your fill weight and travel distance ● Identifying the max. load for the selected e-chain®. If you cannot meet your application demands using these parameters, keep in mind these specifications are conservative maximum values. In individual cases, they can be exceeded by up to 30%. Special solutions are also possible. Please consult igus®

# Unsupported | Sag $FL_B$ | Fill weights up to 90 kg/m

Load diagram unsupported

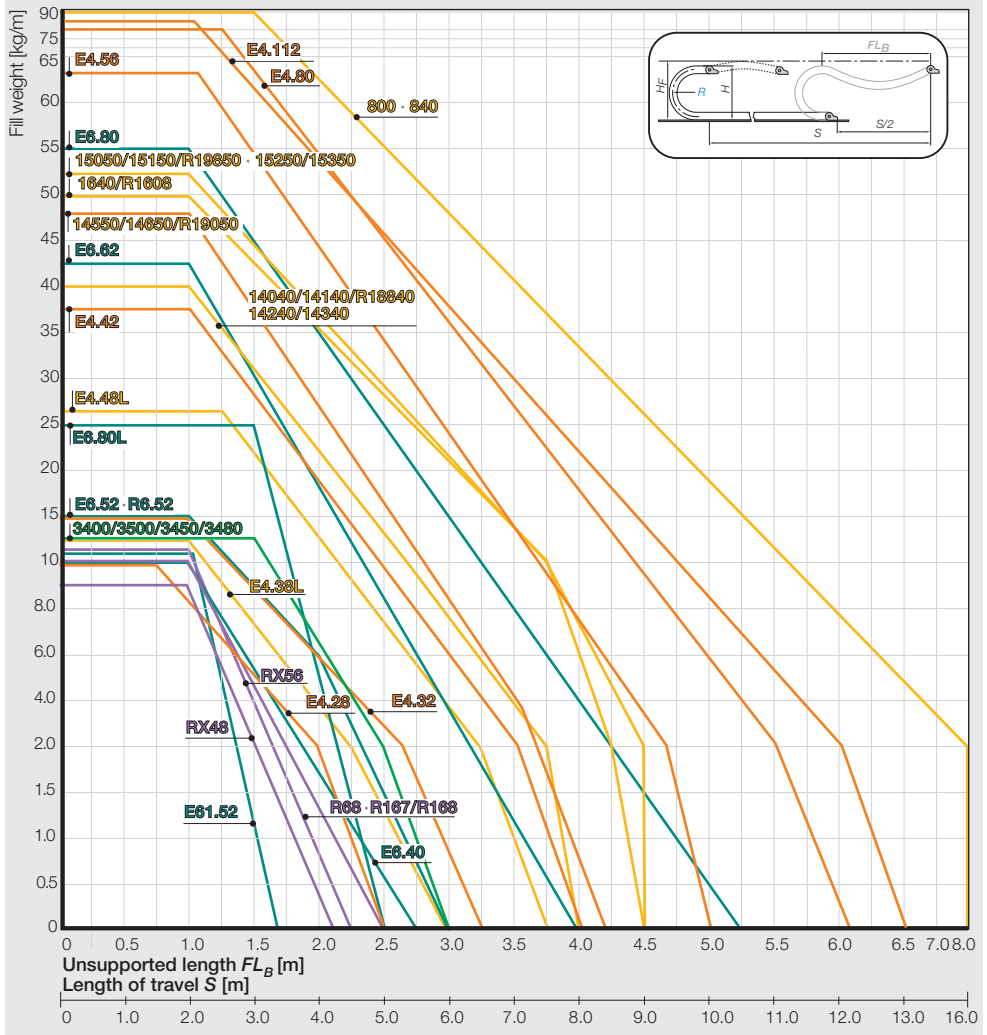
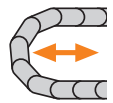

## The maximum travel -

always amounts to  $2 \times 2 \times FL_G$  or  $FL_B$  if the fixed end is in the center of the travel. In this case, the following applies:

$$e\text{-chain}^{\circ} \text{ length: } L_K = S/2 + K$$

$S$  = Length of travel

$R$  = Bending radius

$H$  = Nominal clearance height

$H_e$  = Required clearance height

$K = \pi \times R + (2 \times T)$  Add-on for bending radius

## Series diagrams

You will find both diagrams for each series listed individually in the catalog

- E2/000 ▶ page 240
- E2/RX e-tubes ▶ page 342
- E4.1 ▶ page 362
- E4.1 light ▶ page 422 Values upon request!
- E4/light ▶ page 434
- E6 ▶ page 494
- E6.1 ▶ page 532 Values upon request!

Find the values for " $FL_G$ " and " $FL_B$ " also ▶ in every individual Series chapter!

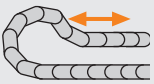

# Gliding | Long Travels



Recommended ratio of inner width  $B_i$  and bending radius  $R$

The minimum inner width of an e-chain® on long travels depends on its bending radius. **igus® specifies:**

$$B_{i \min.} \geq \frac{R}{4}$$



Example of lowered mounting height

## Gliding applications principle

For long travels, the upper run of the igus® e-chains® rests on the lower run. The upper run glides partially on the lower run and partially at the same height on a glide bar. The diagrams below show this. For lateral guidance, a Guide Trough is necessary. If the stationary mounting bracket and the fixed end of the cables and hoses can be placed **in the center**, the e-chain® length is calculated as follows:  $L_k = \frac{S}{2} + K_2$ . Depending on the technical data and the selected e-chain®, the mounting point of the moving end of the e-chain® must be lowered on some units ► **Lowered mounting height**. In our system analysis for long travels, we give exact details for your specific application.

$$L_k = \frac{S}{2} + K_2$$

$L_k$  = e-chain® length

$S$  = Length of travel

$\frac{S}{2}$  = Half length of travel

$R$  = Bending radius

$\Delta CL$  = Offset fixed point

$H_{Ri}$  = Trough inner height

$H_2$  = Installation height\*

$D_2$  = Over length for long travels gliding

$K_2$  = Add-on\*

\*with lowered mounting



Long travel with E4/4 rol e-chain®, guided in a igus® steel guide trough

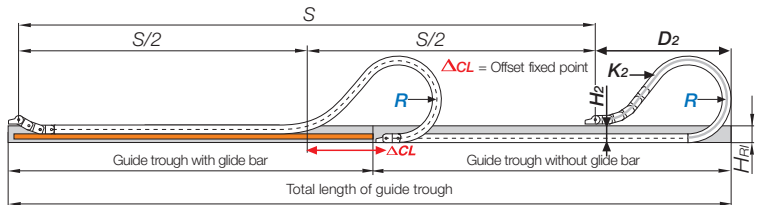

The function of an e-chainsystem® for gliding applications (schematically). The fixed end of the e-chain® is located in the center of the travel distance



Advantages lowered moving end:

- Space saving
- Longer travels
- Higher service life

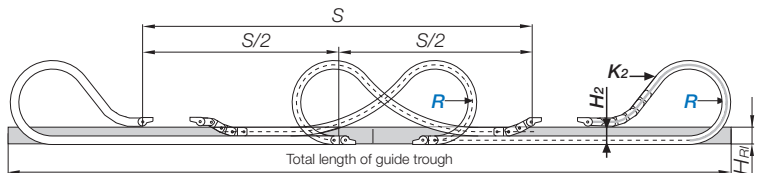
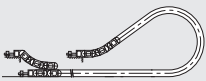

For a configuration involving two opposed e-chains®, the travel is measured as shown and selected when these factors apply: ● Restricted space ● High loads

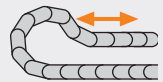

Gliding applications =  
Pivoting mounting brackets

## Advantages for long travel applications with igus® e-chains®

- Travels over 800 m
- 6 m/s speed (up to 10 m/s possible after consultation with igus®)
- Service life of 10 years and more with igus® e-chainsystems®
- Fill weights up to 70 kg/m

### Further advantages of the design are: ●

Many different types of cables and hoses can operate side by side in the same system (i.e. electrical, data, fiber optic cables with hydraulic and pneumatic hoses) ● Space-saving installation ● Quiet operation ● High accelerations ● Durable in wind, weather, dirt, and chemicals ● Simple assembly of the modular system on the spot ● Rapid assembly and replacement of cables and hoses



**E4 e-chain® with extension links for many cables and large hoses on a long travel application**

## Design assistance, free of charge

We recommend that igus® calculate every gliding application for you. We will always offer the most cost-effective solution, taking the technical requirements and operating safety into consideration. The system solution designed by us is also automatically given an igus® system guarantee.

**To be able to advise you accurately, we require the following specifications:** ● Travel [m] ● Travel speed [m/min] or [m/s] ● Acceleration [m/s<sup>2</sup>] ● Fill weight [kg/m] ● Maximum cable/hose outer diameter [mm] ● Type and number of cables and hoses ● Required bending radius [mm] ● Cycle frequency (n/day or n/hour) ● Technical environment.



Please call us and within hours you will receive a detailed system proposal!

**Special solutions for long travel applications without Guide Troughs**

► from page 724



**Longest igus® travel of 615 m with rol e-chain® and chainflex®-cables**

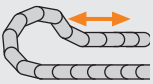

# Gliding | Long Travels



All special solutions for long travel applications without Guide Troughs

► from page 724

- System P4
- rol e-chain®
- autoglide
- guidelok horizontal
- guidelok slimline F
- lbt flizz®
- micro flizz®
- levichain



Long travel application with the largest polymer e-chain® of the world. Series E4.350

## Trends in long travel applications

**Very long travels with igus® rol e-chain. -**

**Rolling instead of gliding:** 75% less push/pull forces due to special roller-links. Travels up to 800 m are possible. Longest igus® travel of 615 m with rol e-chain® and chainflex®-cables

► [igus.eu/eu/rolechain](http://igus.eu/eu/rolechain) ● **Long travel systems "off the reel" - save already at the state of assembling:** Complete custom-made e-chainsystems® with cables, connectors, strain relief - are delivered on the reel and "rolled off" into the preassembled Guide Troughs. Time savings of 50 % possible. Please ask us for references ► [igus.eu/eu/readychain](http://igus.eu/eu/readychain) ● **Long travels without guide troughs:** Our autoglide system consists of self-guiding e-chains® for travels up to 50 m travel lengths (speed 1,5m/s) due to special gliding elements on the cross-bars ► [igus.eu/eu/autoglide](http://igus.eu/eu/autoglide) ● **Long travels with very small e-chains®.** micro flizz® offers the guidance of cables inside a small e-chain® with high acceleration on long travel applications ► [igus.eu/eu/flizz-n](http://igus.eu/eu/flizz-n)

► [igus.eu/eu/readychain](http://igus.eu/eu/readychain) ● **Long travels without guide troughs:** Our autoglide system consists of self-guiding e-chains® for travels up to 50 m travel lengths (speed 1,5m/s) due to special gliding elements on the cross-bars ► [igus.eu/eu/autoglide](http://igus.eu/eu/autoglide) ● **Long travels with very small e-chains®.** micro flizz® offers the guidance of cables inside a small e-chain® with high acceleration on long travel applications ► [igus.eu/eu/flizz-n](http://igus.eu/eu/flizz-n)

► [igus.eu/eu/readychain](http://igus.eu/eu/readychain) ● **Long travels without guide troughs:** Our autoglide system consists of self-guiding e-chains® for travels up to 50 m travel lengths (speed 1,5m/s) due to special gliding elements on the cross-bars ► [igus.eu/eu/autoglide](http://igus.eu/eu/autoglide) ● **Long travels with very small e-chains®.** micro flizz® offers the guidance of cables inside a small e-chain® with high acceleration on long travel applications ► [igus.eu/eu/flizz-n](http://igus.eu/eu/flizz-n)

► [igus.eu/eu/readychain](http://igus.eu/eu/readychain) ● **Long travels without guide troughs:** Our autoglide system consists of self-guiding e-chains® for travels up to 50 m travel lengths (speed 1,5m/s) due to special gliding elements on the cross-bars ► [igus.eu/eu/autoglide](http://igus.eu/eu/autoglide) ● **Long travels with very small e-chains®.** micro flizz® offers the guidance of cables inside a small e-chain® with high acceleration on long travel applications ► [igus.eu/eu/flizz-n](http://igus.eu/eu/flizz-n)



Long travel "off the reel." Up to 100 m travel pre-assembled and ready to install



Cleaning of a port basin in Antwerp. On a stroke of 138 meters an e-chain® Series E4.350 guides cables and hoses with a total additional load of 98 kg/m

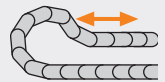

## PPDS - Push Pull Force Detection System

The PPDS-System is an electronic diagnostics tool that performs online monitoring of the displacement forces on the e-chains® in order to avoid system damage and stoppages.

Excessive dirt, ice, and snow and foreign objects that fall into the e-chain® can block the system, causing the e-chain® to ascend and break. The PPDS system measures the displacement forces on the e-chain® several times per second, and compares the information with the calculated specification. If a variance occurs the plant can be automatically stopped with the help of the PPDS system.

3 PPDS systems are available: ● **PPDS basic** **New**

in this catalog ● **PPDS advanced** ● **PPDS pro**



Long travels with electronics Push/Pull-force monitoring with the PPDS System

### Product benefits

- Easy installation by means of non-interchangeable connectors
- Easy programming using the membrane keypad directly at the device
- Compact housing, stable, corrosion resistant, sealed in accordance with IP 65
- The force limit is programmed in tensile and compression direction
- The plant stops when the force is exceeded
- Custom programmable and event logging in the data memory

### Potential applications

Facilities susceptible to interference, such as conveyor systems in power plants, waste incineration systems, and chemical plants, or crane building. Generally with long travel distances that have high fail-safe requirements. For long travel distances, if tensile and compressive force monitoring is needed.

### PPDS basic - Push/Pull force calculation as safety standard **New** in this catalog

So far the realization of Condition Monitoring Systems was limited to large-scale projects, e.g. ship-to-shore cranes. PPDS basic now makes this technology available for all "standard" industrial applications. The simple force measuring function conducted at the mounting bracket of the e-chain® new also provides an emergency stop function for e-chains® in gliding applications under 100 m stroke at a reasonable price. It consists of the PPF-Sensor (igus®-force sensor), the PPDS Easy 2.0 Evaluation unit and a ready-to-install set with connection cables and assembled connectors for the evaluation unit. ● Low-cost system protection ● Emergency Shutdown or alarming in case of system overload ● Space - saving design

### PPDS advanced - Push/Pull force calculation for long gliding applications

The system for very long gliding applications with an igus® floating moving arm (used to compensate lateral movements). The force sensor is integrated in the floating moving arm and works in connection with the PPDS Easy 2.0 evaluation unit.

### PPDS pro - Push/Pull force calculation for very long travels

The system for very long travels, where the highest level of reliability is inevitable. Here the Full PPDS evaluation is used, which can estimate the force limits depending on the position. A load cell is mounted to the floating moving arm.

You can find an online video at ► [www.igus.eu/eu/PPDSbasic](http://www.igus.eu/eu/PPDSbasic)



3 igus® PPDS-systems are available:

- **PPDS basic** **New** in this catalog
- **PPDS advanced**
- **PPDS pro**



PPDS basic **New** in this catalog



PPDS advanced



PPDS pro



Floating moving arm for PPDS advanced and PPDS pro

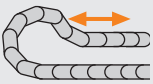

# Gliding | Long Travels



If the fixed point is in the center of the travel, use half of the guide trough with guide bars ... and the other half of the guide trough without guide bars



$Ba$  = e-chain® outer width  
 $Bi$  = e-chain® inner width  
 $ha$  = e-chain® outer height  
 $H_{Ri}$  = Inner trough height  
 $B_{Ri}$  = Inner trough width ▶ depending on  $Ba$

$H_{Ri} \geq 2 \times ha$   
 $B_{Ri} \geq Ba + 4$   
 (Alu SuperTrough)  
 $B_{Ri} \geq Ba + 5$   
 (Steel guide trough)

- Alu SuperTrough-set
- Glide bar
- Installation set"Basic"
- C-profile

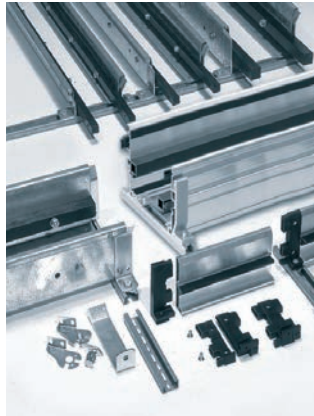

Various guide trough systems are available

▶ Guide Troughs, page 656

## Long travels with igus® Guide troughs

Guide troughs are used for long travels. They allow igus® e-chain® and e-tubes to continue smooth, low-friction operation in these long-travel situations. Principle sketches are shown on this page. The height of the trough must be at least twice that of the e-chain® link height. The sides must provide a chamfered opening. The trough inner width is the same as the e-chain® outer width, plus 4 mm (on Alu SuperTroughs)  $B_{Ri} = Ba + 4$ . Along the side of the trough, where the upper run cannot glide on the lower run, glide bars must be installed. We recommend the use of polymer glide bars from igus®. They are optimally matched to the e-chain® material and achieve the lowest values for friction, noise and wear. Guide troughs with and without glide bars can be obtained for almost all igus® e-

chains®. **Important: When assembling the trough parts, the following points must be given particular attention:** ● Properly align all trough parts upon installation ● All screw heads should be flush with the trough ● Smooth levelled transition between the end of the e-chain® and the glide bars ● Solid connection with the glide surface. **These points must be observed when using assembly-friendly igus® guide troughs.**

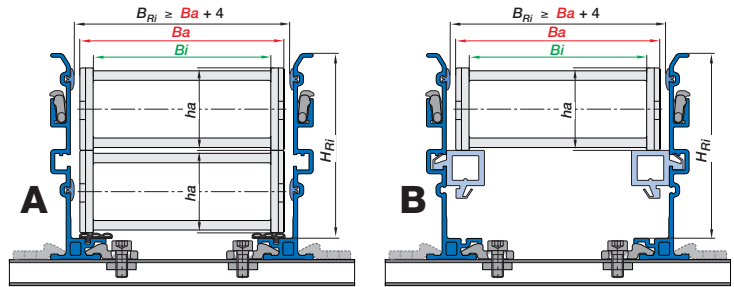

A) Aluminum SuperTrough without glide bars - upper run glides on the lower run

B) Aluminum SuperTrough with glide bars. We recommend the use of polymer glide bars from igus® made of igulen. They are optimally matched to the e-chain® material and achieve the lowest values for friction, noise and wear.

## Glide friction values for igus® e-chains®

made of igumid G / GLW and various glide bars

igumid G / GLW	igus® polymer bar igulen	Glide sheet steel	Anodized aluminum	Stainless steel
Friction value	0,19	0,45	0,54	0,48
dynamic				

Quelle: igus® Labor



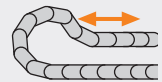

## Travel speeds and accelerations

Travel speeds up to 5 m/s in continuous operation are possible and in use on current applications. In special cases, even higher speeds are possible. For example, E4 e-chains® achieve **speeds of 22 m/s and accelerations of 784 m/s<sup>2</sup>** in crash test units. (Only a few thousand cycles per year are required in this situation.) Acceleration plays a large role in the calculation. Differentiations must be made between normal operational acceleration and a sudden jolt of acceleration such as unexpected stops or so-called "E-stops." Even in these situations, igus® e-chains® prove to be very durable.



Automated storage/retrieval system with System E2 and chainflex® cables - travels up to 80 m and speed of 4.5 m/s

## Service life

We offer service life calculations for your application based on our extensive gliding application experience. As developers of polymer plain bearings, we possess vast material behavior knowledge which we apply to the development of e-chains® as well. Units with 200 m travels have been in operation for 8 years with minimum maintenance. Units up to 60 m travels have been in operation for 15 years with almost no maintenance. (Please consult igus® for references and calculations for your project.) The maintenance-free aspects of igus® e-chainsystems® over long periods and under rough operating conditions is often the deciding factor in choosing igus®. Our system guarantee (depends on the application) provides additional peace of mind.

## Technical environment

Long travel applications using igus® e-chains® run in water, in dirt, in the tropics, in explosion risk areas (with special design features) and many other conditions. Guide troughs can be supplied in corrosion-free materials. You will find more details in the Technical Environment section of this chapter.

## Calculation

Comprehensive tests place us in the position of knowing our products capabilities. Important factors in these tests are: ● Push-pull forces under both ambient and extreme temperatures ● Humidity and dirt ● Friction values of the polymers, alone and against various glide surfaces ● Behavior of electrical conduits under push-pull conditions ● Behavior of hydraulic and media hoses under push-pull conditions ● Service life, and noise generation. **If we cannot calculate your application based on these factors, we will perform a practical test for you in our laboratory. Please consult igus®.**



**Corrosion-free guide troughs are available in the material:**

- Normally galvanized
- Upon request: Stainless steel  
Material 1.4571/1.4404
- Seawater resistant aluminum



**Special properties - Long travel applications**

For higher fill weights igus® develops unconventional solutions and delivers standard parts from stock or special parts from stock or on short notice. e-chains® that are nested can be used in gliding applications when there is width restriction. Guide troughs with special wall heights are required. e-chains® running side by side or in "multiband" design can also be used.

## Technical data - Gliding applications

Travel max	600 - 800 m
Travel speed max	10 m/s
Travel acceleration max	dependent on calculation, can be 50 m/s <sup>2</sup> and more
Fill weight maximum	dependent on calculation, can be 70 kg/m and more



# Application | Vertical Hanging



We recommend locking mounting brackets for hanging applications.

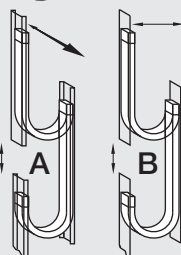
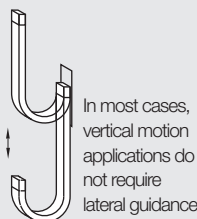

Lateral acceleration can occur in two directions - guidance is necessary

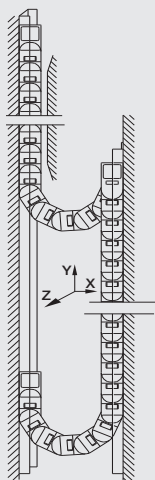

Principle of a hanging e-chain® with lateral guidance - lateral accelerations in both directions are intercepted



Standing applications with heights over 100 m are possible with e-chains®



Hanging assembly with one-sided U profile

## Vertical, hanging applications

In accordance with the principle of "hanging" applications, heights of over 100 m are possible with igus® e-chains®. e-chains® with interior separation allow many different types of cables and hoses to operate together in the same system without becoming entangled.

## Cables and hoses

Two important factors in vertical hanging applications are how the cables and hoses lay in the e-chain® and how they are secured at the end points: All cables and hoses must be hung so that they bear their own weight. The e-chain® fulfills the function of orderly conduit bundling only and should not absorb any further tensile forces. igus® interior separation elements should be used for distinct division of all cables and hoses. The cables and hoses must be secured carefully to both end points of the e-chain®. The strain relief must be designed so that the opposite run cannot catch. Safe strain relief and clear separation of the cables and hoses are the basic prerequisites for hanging installations - **Cables must be able to move freely and bear their own weight.**

## Vertical motion with lateral acceleration

If lateral acceleration occurs, lateral guidance of the e-chain® must be provided in most cases. The diagram to the right shows the principle of such guidance. Partial guidance is also an option - however, it must at least cover the area in which the e-chain® may sway. Lateral acceleration can occur in two directions. The lateral guidance must be installed accordingly. If you have a choice, the layout in **Figure A** is preferred. Additional guidance along the side of the e-chain® helps to stabilize the e-chain® further.



With E4.1 it's easy to create a NC-version. Simple turn e-chain® outer link

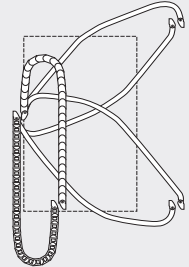
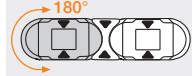

Hanging and standing e-chainsystems® can reach to very different points

## "No Camber" - Special "NC" e-chains®

A normal igus® e-chain® with camber is suitable for hanging use if enough space is available. If there is no room - as is frequently the case for storage and retrieval systems in narrow aisles - a "no camber" e-chain® must be ordered. For long travels (gliding) we recommend also NC-version e-chains®.

**With E4.1 it's easy to create a NC-version. Simple turn e-chain® outer link. Order example: E4.32.10.175.0.NC (NC = no camber).**



The E4.1 system is one of igus® best solutions for hanging applications

### Technical data - vertical hanging

Travel height max:	100 m
v max:	20 m/s dependent on height and stability of the e-chain®
a max:	50 m/s <sup>2</sup> dependent on height and stability of the e-chain®

## guidelok slimline F

**No rattling and knocking during lateral accelerations - cables guided safely upward up to 50 m.**

High speeds of 7 m/s are no longer a rarity for lane travels of highly dynamic storage and retrieval units. The e-chains® are guided safely even at very high speeds with the new generation igus® guidelok slimline. The product range has been expanded to series 2700 and 3500 - now higher fillings and higher loads are possible.

- Up to 7 m/s and 10 m/s<sup>2</sup>
- Save up to 80% on trough parts
- Save significantly on costs and system weight
- For hanging applications up to 50 m high
- No swinging of the e-chain, high reliability- through lever mechanism and guiding rails
- Faster and easier installation
- Significant noise reduction
- Easy access for servicing
- Energy + data + media are conducted safely and without interruption in one system



**Typical application areas:**  
**Storage and retrieval equipment, lifters, elevators, builder's and crane lifts, hoists, AKL's**  
**More information online**  
**► [www.igus.eu/eu/guidelok](http://www.igus.eu/eu/guidelok)**



**Note:** Systems of this type should be designed by our system design engineers. We will be more than willing to submit an offer to you. Please contact us about this.



Standard

We recommend locking mounting brackets for standing applications

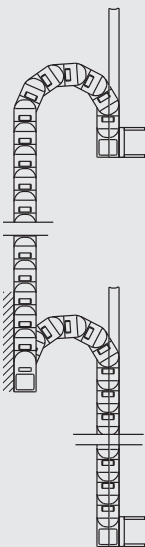

Options for a standing application with support of the first e-chain® links: on the right, with U-shaped guidance - on the left, with the support of the first e-chain® links

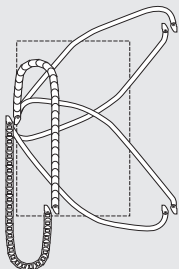

Standing e-chain systems® can reach to very different points

## Application | Vertical Standing



Locking KMA mounting brackets with flush mounting



U-shaped supported e-tube for high lateral acceleration

### Vertical - standing applications

Standing applications are standard on many machines and plants. Cables will be guided safely in vertical strokes.

### Mounting brackets

The mounting brackets must be attached so that the e-chain® cannot bow out. The igus® program offers locking or one-sided, locking mounting brackets for almost all types of e-chains®. Locking KMA mounting brackets are highly recommended because they can be attached flush to the machine.

### Cables and hoses

Cables and hoses must be laid in the e-chain® so that they can bend freely. For precise guidance of the cables and hoses, we strongly recommend igus® interior separation elements. Cables must be strain relieved at both ends.

### Lateral acceleration

If lateral acceleration occurs, the e-chain® should be supported along the outer radius. For higher e-chain® heights, it is generally recommended that at least the first three links on the outer radius be supported. For maximum heights and weights, the whole distance must often be supported. Due to the wide variety of combinations involving weights, stroke heights, e-chain® types and bending radii, we strongly recommend you make use of our consulting services.

### Combined movements

Combined vertical and horizontal movements are possible with igus® e-chains® for a cost-saving solution.

### Technical data - vertical - standing applications

Max. stroke height - without support	≈ 4 m
Max. stroke height - with support of the first e-chain® links	≈ 6 m
Max. stroke height - with full support	≈ 20 m
v max (dependent upon stroke height and weight)	20 m/s
a max (dependent upon stroke height and weight)	50 m/s <sup>2</sup>

More examples for standing applications ► [www.igus.eu](http://www.igus.eu)



We recommend pivoting mounting brackets for Zig-Zag applications



Decommissioning of a nuclear power station.  
Zig-Zag application with igus® e-chains®

## "Zig-Zag" design

The modular design of igus® e-chains® facilitates this space-saving and unconventional solution. For modern platform technology, such as performance stages, a variety of cables and hoses which adjust the stage height must be accommodated. Lack of space almost invariably presents particular difficulties. The photo above shows an e-chain® in a "Zig-Zag" configuration produced by incorporating reverse bend radii or "RBR". The unextended e-chain® is stored in a "basket" underneath the stage. If the stage is raised, the e-chain® unfolds, generating little or no noise. This construction is possible with the E4.1 System as well as many other types. Please consult igus® for these kinds of applications.

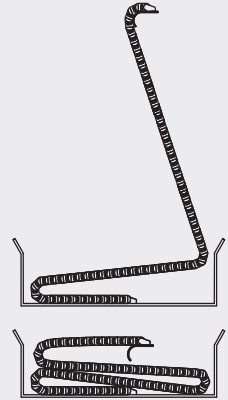

Space-saving installation -  
Travel heights of more than  
20 m possible

## Technical data - Zig-Zag

Travel max.	40 m	(more upon request)
v max	0,4 m/s	depending on the application, please check with igus®
a max	1,0 m/s <sup>2</sup>	depending on the application, please check with igus®

liftband **New** in this catalog

## Modular, silent, space saving - guide media, energy and data up and down:

High vertical applications that have plenty of space horizontally but allow only for little system height can be implemented with the liftband.

- Very high travels are possible
- Less abrasion, as there is almost no friction of the e-chain® links with each other
- Little limitation of cable bending radii
- Silent operation and space saving
- Simply press cables in



Typical application areas:  
Stage technology, alternative to zig-zag applications. More information online  
▶ [www.igus.eu/eu/liftband5](http://www.igus.eu/eu/liftband5)





We recommend locking mounting brackets for side-mounted applications



Side-mounted e-chains® - are strongly recommended if the installation height is restricted

Standard values for unsupported lengths, side-mounted, upon request. The unsupported lengths can be extended by supporting the links next to the mounting brackets



E4 e-chains® assembled in an unsupported manner on the traveling column machine. The Y and Z axes have a travel of 8,000 mm and 1,750 mm at a speed of 25 meters per minute

## Application | Side-Mounted

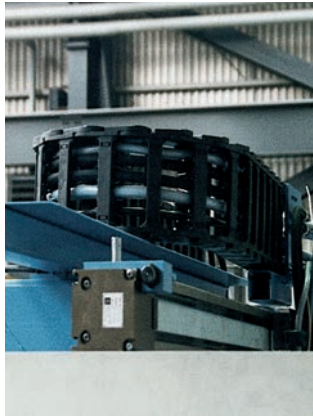

**e-chain®, side-mounted, supported System E4**

Short travels with or without support  
igus® e-chains® placed on their side can be used unsupported to a limited extent. The turned "unsupported length" in this case is dependent on the following factors: ● **Fill weight** ● **Width of the e-chain®** ● **Bending radius** ● **Parallel placement**. The greater the fill weight of the e-chain®, the shorter the available unsupported length. When placed on its side, the e-chain® width, in effect, becomes the height. As this "height" increases, the e-chainsystem® becomes proportionally more stable. Small bending radii provide greater stability. If further movement in a second axis is added to the parallel motion of two e-chains®, the unsupported length is impaired. For applications with low fill weight, the standard mounting brackets are adequate. If, however, the fill weight is high and the travels are long, the e-chain® must then be supported either in whole or in part. Due to the variety of application possibilities, we strongly recommend you make use of our consulting services.

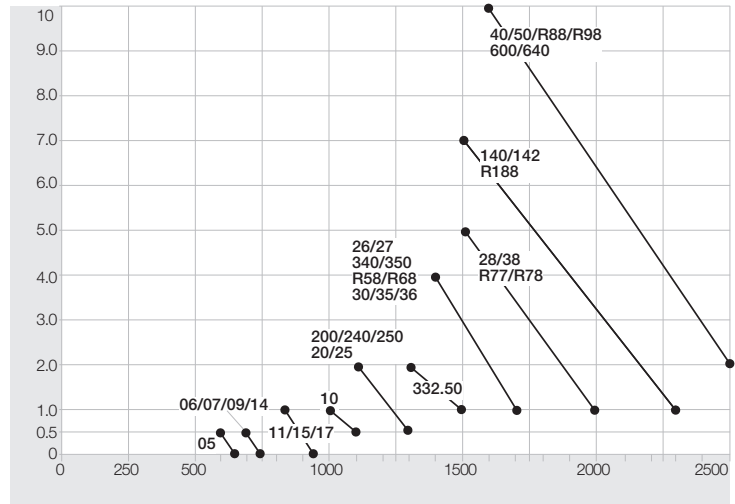

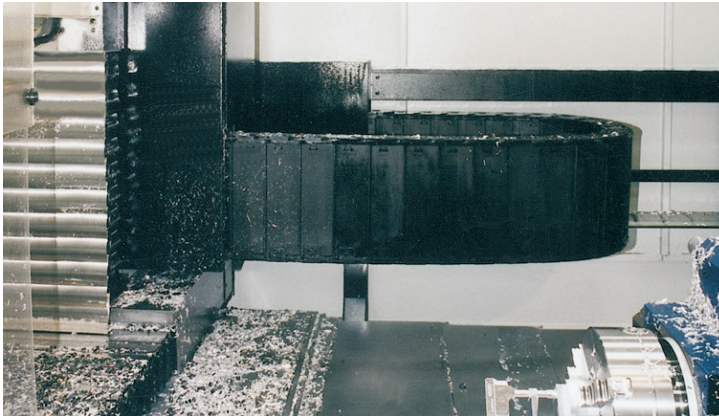
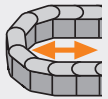

System E4/light e-tube in direct chip area

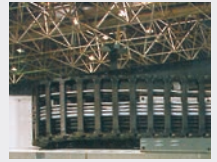

igus® - Series E4  
with partial support



Unsupported - System E4

## Long travel, gliding

Side-mounted e-chains® can travel over 100 m with adequate guidance. All e-chain® types are designed to operate gliding on their side. The corresponding glide surface is usually an igus® polymer, stainless steel or galvanized steel, depending on how high the demands on the travel speed and service life are. Roller and ball bearings or additional gliding elements are not necessary for igus® e-chains®.

## Cables and hoses

Cables and hoses must be guided so that the e-chainsystem® can move freely at all times. The igus® modular separation options offers numerous possibilities, such as vertical separators and spacers, to keep these cables and hoses separated and bending freely for maximum service life. igus® will gladly provide an application analysis, free of charge.

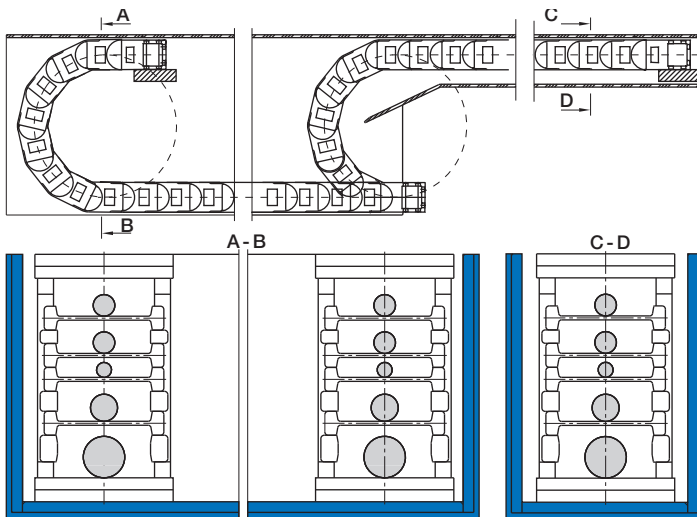

Principle of a guide trough for long travel, side-mounted



# Application | Rotary Motion | RBR

Standard

We recommend pivoting mounting brackets for most applications with rotary motions

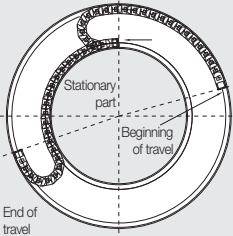

"RBR"-rotary movement with Series 5050, installed on a crane

## Rotary motion with "RBR"

"RBR" is "reverse bending radius" and means that the e-chain® can bend in two directions. Each igus® e-chain® can incorporate RBR designs, with the exception of several radii, for the e-tubes R117 to R9850 and for the Series 07, 09, 14, 15, and 17. The RBR does not necessarily need to be identical to the normal bending radius of an e-chain®. For example: Part No. **E4.32.15.100/425.0**, describes a Series 280 e-chain® with an inner width of 150 mm, standard bending radius of  $R = 100$  mm and RBR of 425 mm.

Most rotary motions can be achieved with the RBR option. **Angles of rotation up to 540°** have been realized. Below is an example of rotary motion using an RBR e-chain®. Please consult igus® for your particular application.



### Technical data - rotary motion RBR:

max. angle of rotation = 540° (more upon request)  
 $v$  max = 10 m/s  
 $a$  max = 2 m/s<sup>2</sup>



Rotary motion with a "standard" e-chain®

Rotary movements require less installation height. The e-chains® glide mostly on surfaces made of polymer, stainless steel or steel and are guided through channels into a rotary movement. (See "side mounted" for further design tips.) Bending radii, circular radii and e-chain® widths are variable with this product line

## Rotary motion with standard e-chains®

The photo to the left shows an application which was achieved using "standard" e-chains® (in this case, standard means that the e-chain® only bends in one direction). Such solutions are possible if **a great deal of space** is available and if the angles of rotation are limited to a maximum of 450°. All igus® e-chains®, e-tubes and chainflex® cables are appropriate for this situation.

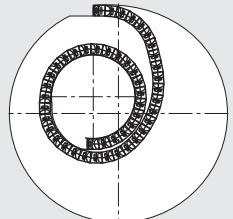
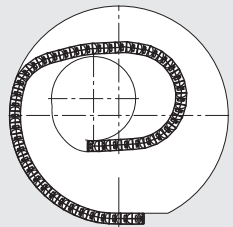

Standard e-chain®  
**3500.075.200.0**,  
 angle of rotation 225°

### Technical data - rotary motion RBR

max. angle of rotation	540°	more upon request
$v$ max	2,0 m/s	more upon request, depending on the application
$a$ max	20 m/s <sup>2</sup>	more upon request, depending on the application





Guide trough systems RM and MRM for RBR solutions

► next page

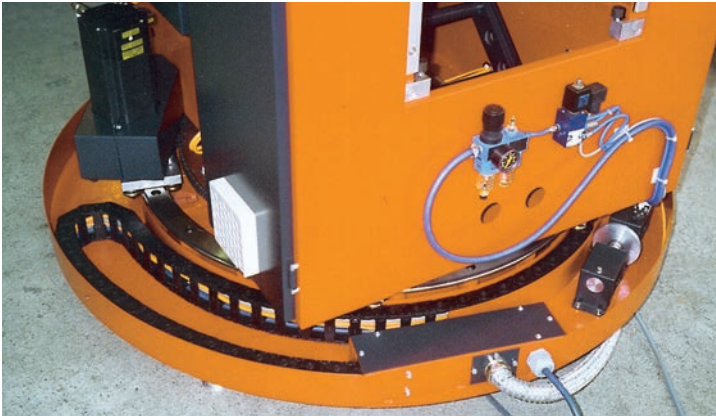

System E2 medium with 360° RBR rotary motion on a robot

## Delivery program for rotary motions with RBR

e-chains® with "RBR" are available as standard from stock for the complete triflex® range. In addition, we supply a number of e-chains® which are equipped as standard with "RBR". For all other types, "RBR" means custom-made, and we will be more than willing to offer you this option. igus® e-chains® with "RBR", available as standard ► triflex®R, easy triflex® and triflex®. **The e-chain® Series appearing in the table are "RBR" - versions available from stock. Almost all igus® e-chains® can be delivered as a "RBR" - version. Please contact us for any special inquiry**

- chainflex® cables with TPE-outer jacket are specially suited for e-chains® with "RBR" option
- Please use for e-chains® with "RBR"-option a strain relief only for the moving end

## Table of "RBR" e-chains® available from stock

Part. No.	Series	Part. No.	Series
03.05.10/70	E2 micro	10.4.038/600	E2 mini
05.16.018/018	E2 micro	10.4.048/048	E2 mini
06.20.018/018	E2 micro	10.4.048/400	E2 mini
06.30.018/018	E2 micro	10.4.075/220	E2 mini
06.64.018/018	E2 micro	1500.038.075/450.0	E2/000
10.1.028/028	E2 mini	2400.09.055/250	E2/000
10.1.038/600	E2 mini	250.05.060/060	E2/000
10.1.048/048	E2 mini	250.07.060/060	E2/000
10.1.075/220	E2 mini	2700.15.150/090	E2/000
10.2.028/028	E2 mini	B15i.050.100/460	E2 mini
10.2.038/600	E2 mini	E/Z14.1.038/038	easy chain®
10.2.048/048	E2 mini	E/Z14.2.038/038	easy chain®
10.2.075/220	E2 mini	E/Z14.3.038/038	easy chain®
10.3.028/028	E2 mini	E/Z14.3.075/075	easy chain®
10.3.038/600	E2 mini	E/Z14.4.038/038	easy chain®
10.3.048/048	E2 mini	TE14.50.028/028	snapchain
10.3.075/220	E2 mini	TE26.120.063/063	snapchain
10.4.028/028	E2 mini		



The e-chain® Series appearing in the table are "RBR" - versions available from stock. Almost all igus® e-chains® can be delivered as a "RBR" - version. Please contact us for any special inquiry!



**Available from stock.**  
**Delivery in 24h or today!**  
 Delivery time means time until shipping of goods (after technical release)



# Guide Troughs | Rotary Motion | RBR



Rotary motion with RBR, diameter 6000 mm, with RBR, the inner ring rotates



System RM - Guide troughs for rotary motion applications

## Guide Troughs- standard modular system RM

For rotary motions up to 540° igus® offers a modular system of guiding trough systems. Those systems are divided into an inner and an outer ring. Since one ring is moving together with the e-chain® there is no relative movement between e-chain® and trough, so the wear is reduced to an absolute minimum. Depending on the application they are made from galvanized steel or stainless steel.

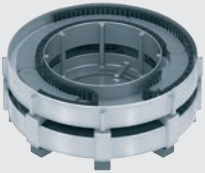

Typical application areas: Offshore, stacker and reclaimer, bucket-wheel excavators, rotary cranes, other rotating applications

## Realize 900° and more with igus Multi Rotation Modules (MRM)

igus® Multi Rotation Modules help to realize rotating movements up to 900° and more. Thanks to stackable add-on modules the angle of rotation can be extended "virtually" indefinitely. The Multi Rotation Modules are ideally suited also for rotary motions with high fill weights and limited space.

- Several individual systems are stacked on each other and form a complete system
- The maximum rotation of the individual levels can be easily added, thereby enabling rotary motions up to 900 degrees and more
- Compact design enables the operation even in tight spaces, extendable "at will"
- High additional loads possible
- e-chains® can be freely assembled
- Peripheral speeds up to 1 m/s
- One layer for rotation movements up to 540°, two layers for up to 900°, higher rotation angle possible with more layers

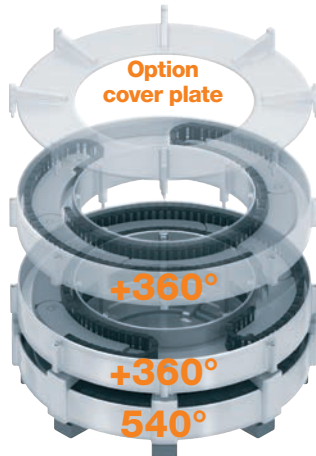

## Functional principle

- If the defined rotation angle of the lower layer is reached, the next upper module is carried along automatically due to an integrated anchorage system
- The construction minimizes potential interferences. The Multi-Rotation Module-System is ideal for rotary applications, heavy loads and for rough environments
- Contrary to e.g. sliding contacts, the e-chain® can also guide hoses for air, gas or fluids, as well as bus and fibre optic cables
- Use also under harsh environmental conditions

# Rotary Motion | twisterchain® | c-chain®



## Rotary motion with twisterchain®

Higher loads and smoother running. igus® new generation of twisterchain® new circular e-chains® significantly improved smoothness, stability and strength. The twisterchain® new has a modular construction for width, height and radius and therefore provides very flexible use in applications where rotating movements up to 540° are required.



Rotary motion with new igus® generation of twisterchain®

- Rotary speeds up to 1 m/s and more
- Rotary/spiral movements up to 540°
- Sturdier through intermediate link - more additional load possible
- With the new generation of twisterchain® guide troughs - Save assembly time and costs - increase cycle life!
- Cable-friendly, smooth interior
- Crossbars snap-open along inner radius



Typical application areas:

- Robots, handling machines
- Packaging machines
- Glass machines
- General mechanical engineering

## twisterband -

### Rotary movements in minimum space - 20 times around its own axis

With the very compact igus® twisterband rotations can be implemented economically and with low wear and low maintenance in a confined space. Energy (in the process), data and media are kept secure.



twisterband application of two systems mounted above one another

- Rotary movements up to 7000° (Installation position, vertical: up to 3000°, horizontal: 7000° and more possible)
- Rotary speeds up to 360°/s possible
- Minimum installation space, runs very close around the rotary axis
- Can be reliably used in various installation positions (horizontal or vertical)
- Compact, modular and lightweight



Up to 7000° rotary motions in smallest spaces

## c-chain® - modular kit of continuously revolving e-chains®

igus® offers standardized modules of the c-chain® system for many e-chains® of the series E4.1. This enables quick product solutions that are customized to the application. The avoidance of unused down journeys creates new perspectives. ● Compact, modular ready-to-install system ● Energy supply plus bus cable and pneumatics ● Speeds up to 3 m/s ● Travel distances up to 50 m and more

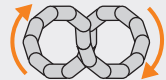

### Delivery program c-chain®

E4.21.050.075	E4.56.13.300*
E4.21.080.200*	E4.56.26.300*
E4.28.075.200*	E4.80.12.300*
E4.32.07.200*	E4.80.26.300*
E4.42.06.300*	E4.80.26.400*
E4.42.15.300*	

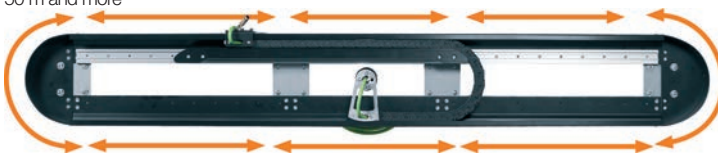



## Rules for:

- Maximum conduit diameters
- Separation
- Bending radius

Electrical cables need at least 10% reserve space all around, hydraulic hoses need 20%

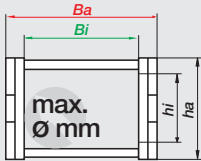

The maximum conduit diameter is specified for each Series on its respective page

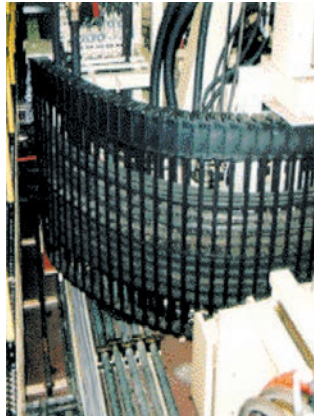

Hydraulics and electric cables are separated from one another in this example

detailed recommendations. Due to the variety of the application parameters, we strongly recommend you take advantage of our free consultation services. Simply give us a list of your cable requirements (or merely the required electrical or other services) and you will receive our recommendation by the end of the next business day.

## Maximum cable and hose diameters

The maximum cable and/or hose diameter corresponds to the inner height of the selected e-chain®/ e-tube, with additional minimum clearance. This minimum clearance would be, for example, 10% for electrical round cables, 20% for hydraulic hoses. An e-chain® is ideal if a minimum lateral gap to the next cable or hose has been factored in. Depending on the nature of the cables, the dynamics, and the expected service life, more clearance must be allowed. In specific cases, clearances may be altered further. Please consult igus.



Orderly laid cables with igus® interior separation

## General rules for cables and hoses in e-chains®

The key advantage of an igus® e-chainsystem® is the safe accommodation of various forms of data cables and energy suppliers in one system. We recommend the optimal separation layout of the cables and hoses in the e-chain®, but you, the customer, are still afforded the final choice. It is possible, for instance, to maintain minimum distances between bus and motor cables and mix pneumatics, electric and hydraulics in the same compartments. In addition to the quality of the cables used, the arrangement of each conduit within the e-chain® and the space allowed, are important for the service life of the system. Various separation options enable the adaptation of the e-chains® to the specific requirements of each respective application. In this chapter, we give you

## e-chain® interior separation

Cables and hoses with very different diameters should be laid separately. The separation is achieved using modular separators. Cables and hoses must **under no circumstances** have the opportunity to tangle. Therefore, the clearance height of a compartment with several similar cables or hoses next to one another **must not amount to more than one and a half times the cable/-hose diameter**.





## Reasons for distribution rules

The cables and hoses must be laid so that they can move freely at all times and so that no tensile force is exerted at the radius of the e-chains<sup>®</sup>. For high-speed applications and high cycles, cables or hoses must not be laid on top of each other without horizontal separation. The standard values for this are: Travel speed over 0.5 m/s and cycles over 10,000 p.a. igus<sup>®</sup> interior separation offers a safe solution for this situation.

## Further guidelines for distribution

The cable or hose weight should be symmetrically distributed along the width of the e-chain<sup>®</sup>. Cables and hoses with different outer jacket materials must not be allowed to "stick" together. If necessary, they must be laid separately. All igus<sup>®</sup> chainflex<sup>®</sup> cables can be combined with each and other brands of cable or hose. The cables and hoses should always be fixed at the moving end. The fixed end should always involve strain relief. Exceptions are made only for certain hydraulic hoses with length compensation issues or other high pressure hoses (i.e. hydraulic hoses). **Generally, the faster and more frequently the e-chain<sup>®</sup> operates, the more important the exact positioning of the cables and hoses inside the e-chain<sup>®</sup> becomes.** Due to the wide variety of the possibilities, we strongly recommend you take advantage of our free consultation services for your specific applications. igus<sup>®</sup> tip: Interior Separation configurator ► [www.igus.eu/eu/quickchain100](http://www.igus.eu/eu/quickchain100)

## Bending radius R

The bending radius of our e-chain<sup>®</sup> depends on the "thickest" or "stiffest" cable or hose in your application. The bending radii of the e-chains<sup>®</sup> should be adjusted to the recommendations of the cable or hose manufacturer. The selection of a larger radius than the minimum will positively affect service life. The specification of minimum bending radii for cables and hoses refers to use at normal temperatures - other bending radii may be recommended. Please ask your cable or hose supplier for details. We recommend complete e-chainsystems<sup>®</sup> - where bending radii for all cables and hoses, interior separation and service life are optimally matched. igus<sup>®</sup> chainflex<sup>®</sup> cables permit the smallest bending radius of 4 x d for one million strokes.

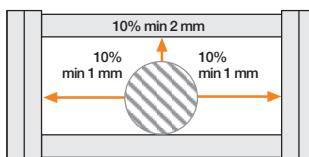
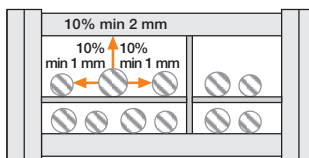
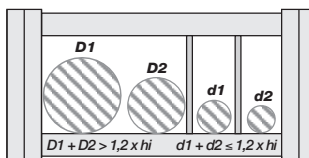

Clearance space "all around" for round electrical cables



e-chain<sup>®</sup> with extension links supports a smaller e-chain<sup>®</sup> with electric cables



### Distribution rules:

**$D1 + D2 > 1,2 \times hi$**

#### Rule 1:

If  $D1 + D2 > 1,2 \times is$  is e-chain<sup>®</sup> inner height, no separation between the two cables/hoses is necessary. Two cables/hoses should never be left unguided on top of one another or be allowed to become tangled.

**$d1 + d2 \leq 1,2 \times hi$**

#### Rule 2:

If  $d1 + d2 \leq 1,2 \times is$  is e-chain<sup>®</sup> inner height, a vertical separator or a horizontal shelf must be used to reduce the inner height, thereby preventing the entanglement of  $d1$  and  $d2$ .

### All-around clearance space in % for various cables/hoses

Electrical round cables	10 %
Electrical flat cables	10 %
Pneumatics	5-10%
Hydraulics	20 %
Media hoses	15-20 %

Please note: dont fill e-chains<sup>®</sup> and e-tubes more than 80% of the cross-section!

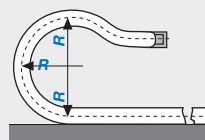

Principle sketch bending radius "R"



**Corkscrewing: an effect of improper cable and hose placement in an e-chain®**

## Round electrical cables

For electrical cables, the round cable is a safe, modular and cost-effective solution for e-chainsystems®. We recommend the following criteria for selecting the proper round electrical cables: ● Small minimum bending radii and mounting heights ● Strain relief integrated directly into the mounting bracket ● Uncomplicated installation process - no hanging, laying out, etc. of cables ● Long service life at minimum bending radius ● Service life expectations for your application (short or long travel, hanging, etc.) ● Test data on service life from realistic tests ● Flexible shields for shielded cables ● Abrasion-resistant and non-adhesive outer jackets ● Large selection to avoid expensive custom designs. For bus cables and fiber optic cable, special attention must be paid to how effective transmission rates and shielding remain after millions of cycles at the minimum bending radius.

### Installation and strain relief of round electrical cables

- 1) The cables must be laid straight, without twisting. Cables must not be uncoiled from the top of the spool. igus® chainflex® cables are immediately ready for placement directly into the e-chain®. They need not be disconnected or laid out before installation.
- 2) The cables must be laid so that each individual cable can move freely from side to side.
- 3) The cables must be able to move freely along the radius. This must be double-checked if the upper run operates at the cable's maximum bending radius.

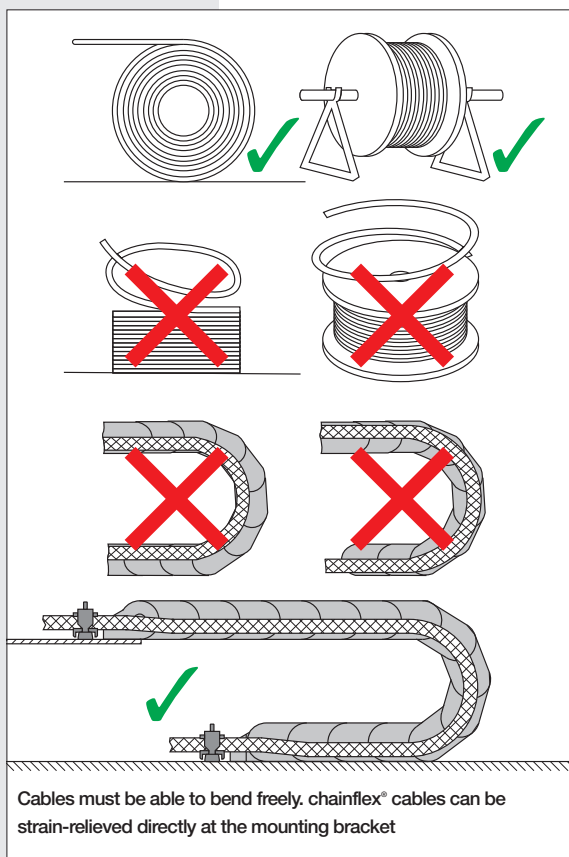

- 4) The division of the e-chain's® interior using igus® interior separators or shelves is necessary if several cables and/or hoses with varying diameters are laid out. It is important to prevent cables and hoses from tangling.
- 5) For cables and hoses with different jacket materials, it is important to prevent them from "sticking" to one another. If necessary, they should be separated. igus® chainflex® cables can be combined with all others.
- 6) Round electrical cables must be secured with strain relief at both ends. In exceptional cases, the cables may be fixed with strain relief at the moving end of the e-chain® only. A gap of 10-30 x cable diameter between the end of the bending segment and the fixed point is recommended for most cables. chainflex® cables can, on the other hand, be secured directly to the mounting bracket with strain relief (this has been confirmed with testing).

We will be pleased to provide you with recommendations for complete e-chainsystems®: Bending radii of all cables and hoses, interior separation and service life are then optimally intermatched.



## Pneumatic hoses

In principle, the same rules apply for pneumatic hoses as for round cables. In practice, it has been demonstrated that pneumatic hoses are less susceptible to wear. After consultation, they can be laid together more closely than the "10% clearance all-around" rule. A double-sided strain relief is required under these conditions. For pneumatic hoses made of rubber, we recommend strictly following the "10% clearance" rule because they tend to adhere to each other and to other cables and hoses.

## Flat cables

Flat cables must be able to move freely along the bending radius. Two flat cables next to one another should be kept apart with separators. If two flat cables are laid on top of one another, we strongly recommend the use of horizontal igus® shelving. Flat and round cables should be laid separately in the e-chain®. Strain relief should be attached at both ends. Flat cables are only conditionally recommended for use in e-chains®.

## Hydraulic hoses

When designing hydraulic hoses in e-chains®, special attention should be paid to the expansion of the hoses when pressurized. Sufficient room must be left in the e-chain® for this as well as the possible larger external diameter of the hoses under pressure. It is important for selected hoses to be sufficiently flexible (i.e. meet bending radius specified by the e-chain®). The gliding ability and abrasion-resistant surface of the hoses are also important. All crossbars and shelves in the igus® e-chain® minimize abrasion of hoses through wide, rounded and smooth surfaces. Normally, hoses with textile braiding are more flexible than hoses made of steel wire, while maintaining smaller outer diameters and better fatigue strength under reverse-travel stresses. As lateral movements of the hydraulic hoses within the e-chain® can lead to increased abrasion of the hose material, they should be secured in position with vertical separators, but not forced. Special "locking" separators, which grip the opening crossbars of the e-chain®, as well as the use of "spacers," prevent lateral shifting of the separators - they also ensure the hoses stay put in cases of strong vibration and impact on the e-chain®.

## Strain Relief

Hydraulic hoses are most often stretched lengthwise during operation. This must be taken into account when applying strain relief. More hose length is factored in to allow the hose to "breathe", or "floating" strain relief must be implemented. In some cases, one-sided strain relief on the moving end can be tolerated.

**Rollclip** - In almost all cases, the broad, smooth and rounded surfaces of all igus® e-chains® are sufficient to protect hydraulic hoses from abrasion. In extreme cases, the igus® Rollclip can be installed. The hoses come in contact with a series of polymer cylinders which rotate. "Extreme" cases include particularly soft materials, particularly narrow bending radii or highly dynamic loads. Over 95% of all applications can be solved without Rollclips.

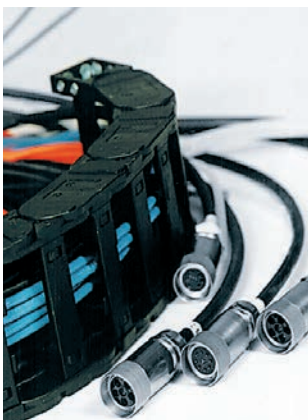

Fully pre-assembled e-chainsystem® with several pneumatic and hydraulic hoses



### ● Pneumatic hoses

The igus® program also offers polymer pneumatic hoses called: "chainflex® Air"

### ● Flat cables

Outer jackets made of rubber must be specified particularly carefully, because of potentially high static friction.

### ● Hydraulic hoses

Hydraulic hoses need more space:  
20% all-around clearance



igus® Rollclip, detachable



Ideally, the cables/hoses should be strain relieved at both ends of the e-chain®. At the very least, they must be strain relieved at the moving end of the e-chain®.

## Strain Relief Elements | chainfix

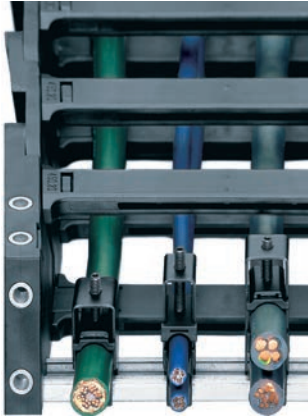

### Strain relief for electrical cables

Strain relief can consist of standard elements or can be custom-made. For most applications, our standard program of C-profiles with mounting brackets and space-saving chainfix clamps can be used. We also offer simple strain relief solutions using cable tiewraps and tiewrap plates. In ideal cases, the cables should be secured at both ends of the e-chain® with strain relief (in a few instances, strain relief at the moving end of the e-chain® is sufficient - please consult igus® for these cases).

### Minimum gap of the strain relief and the beginning of the bending radius

Tests on our premises and in field applications have shown strain relief located at the last bending point of the e-chain® has no influence over the durability of igus® chainflex® cables. It is possible, therefore, to integrate the strain relief with the mounting bracket. This space-saving option for strain relief is offered by igus® for almost all e-chains®.

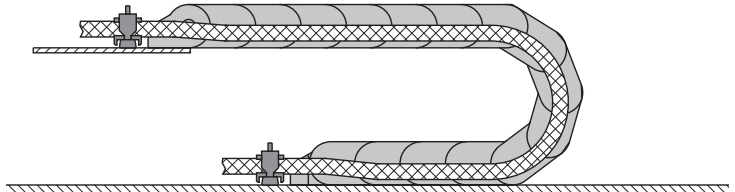

**Ideal installation of cables in e-chains®. chainflex® cables can be directly strain-relieved in the mounting bracket (minimum gap to the last curved e-chain® link is not necessary)!**

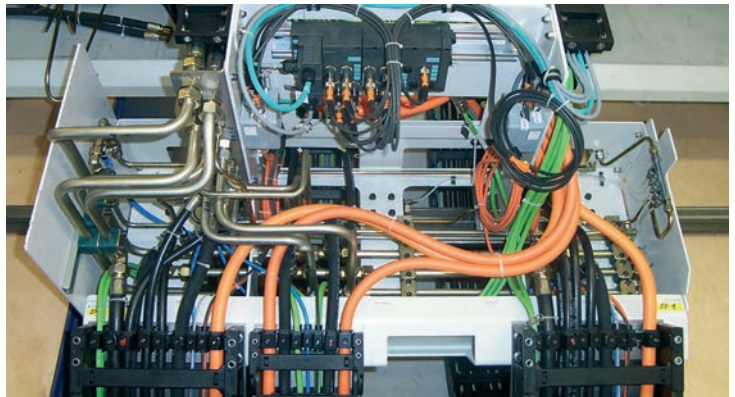

igus® chainfix strain relief in mounting bracket in practice - used here for cables and hoses





## Features of chainfix clamps

Optimal igus® chainfix housing with reduced height ● Long service life for dynamic applications thanks to improved clamping elements ● Integration with KMA mounting brackets - saves both time and space during installation and available for complete systems with cables and strain relief ● Improved housing foot clamp for easy fit into C-profile ● Black housing and setscrews for attractive appearance ● Setscrews, tightened with Allen wrench, for easy installation ● Mark of the installation direction ● Now with better fixation due to optimized design

## Tiewrap plates as individual parts

Separate parts in switch cabinet construction or machine assembly ● Strain relief accessory for igus® e-chainsystems\* ● Attachment to mounting brackets ● Integration into the C-profile of KMA (polymer/metal mounting brackets)

## Tiewrap plates with clip-on connection for the C-profile

The plates **3050.ZC** and **3075.ZC** can be clipped directly into the C-profile without bolts or any extra hardware. Clip-on tiewrap plates can be released and repositioned with just a screwdriver used as a lever.

**4 options available:** ● Tiewrap plates with clip-on connection for the C-profile ● Integrated strain relief for E2 e-tubes - Series R ● Tiewrap plates for fixed crossbars ● Tiewrap plates for opening crossbars

## chainfix clip - modular snap-on strain relief device

chainfix clip is a series of clamps and bottom parts made of plastic for cable diameters ranging from 4 mm to 24 mm. chainfix Clip is available for C-profiles, also suitable for assembly in the KMA mounting brackets and clip-on strain relief for cross bars ● Quick assembly without any tools ● 2 and 3 layers on top of one another possible ● Each layer can be detached and changed later on ● High tensile forces in case of single-layer installation, decreasing with the number of layers

## chainfix nugget - for top hat rail and C-profile

● **Option 1:** Universal cable fixation, for diameter with  $\varnothing$  20 mm and  $\varnothing$  30 mm ● **Option 2:** Fastening through clipping onto standard top hat rail ● The smart helper for electricians in the machine building industry ● Accessory for all KMA with integrated C-profile ● Strain relief for top hat rail ● Easy to assemble, without any screws and tools ● Adjustable to every e-chain® filling ● Very small space requirement ● Easy strain relief due to fixation with pre-harnessed cable strap

## Strain relief separator

● Can be integrated in mounting bracket ● Strain-relief separator can be positioned as required ● Double strain relief possible ● Easy installation, cost-effective ● For most Series available from stock



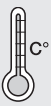

## igus® Materials:

- igumid G / GLW
- igumid NB
- igumid ESD
- igumid TE
- igumid GE
- igumid DT

Find technical data about igus® materials, temperatures and chemical resistance ► **from page 126**



igus® factory - automatic compounding and conveyor belt for igumid G / GLW

## plastics for longer life® - igus® know-how in polymer materials

Each year, igus® engineers develop more than one hundred new plastic compounds and test igus®-products in more than 15.000 experiments per year. That's how in recent years they have built an extensive database of the tribological properties of polymers. This database makes it possible for us to assess better most of the applications in advance and provide our customer with confidence during use. Our calculations and analyses are based on the result of ongoing practical tests in our Technical Center and our experience with gliding applications. The focal points of our tests are push-pull forces, friction values and abrasion under widely varying conditions and speeds, as well as factors such as dirt, weathering or impact and bumps. We test all system components such as cables, hoses, strain relief and other accessories, in addition to the e-chains® or e-tubes and Guide Troughs.

### Technical environment

The igumid G / GLW material, from which igus® e-chains® are made, possesses the following wide-ranging features to cope with a variety of environments: the ability to handle pressure and strenuous loads, abrasion resistance, sturdiness, stable behavior at high and low temperatures, and suitability for outdoor use. Numerous application examples, from refrigerator blocks to steel mills, prove this. In extreme cases, we also offer modifications and other igus® compounds as a solution. Please consult igus®.



## Technical environment:

- Fire resistance
- Radiation
- Weathering
- Cold, heat
- Explosion areas
- Vacuum
- Hot chips
- Dirt, dust
- Cleanroom
- Chemicals

## Magnetically detectable plastic e-chains®

For the food- and tobaccoindustry | **New** in this catalog

- The material igumid DT is detected to the tiniest fragment all common metal detection systems and can therefore be selected automatically
- Particles as small as 1.0 mm can be recognized for fragments passing at speeds of 20 m/min

Further Information ► [www.igus.eu/eu/detectable-chain](http://www.igus.eu/eu/detectable-chain)

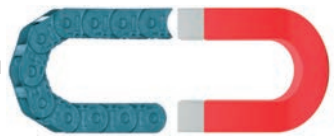

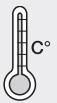

## Flammability of igumid G / GLW

The flame-retardant characteristics of igumid G / GLW can be described using various classifications: Test procedure VDE 0304 parts 3-5.70 - classification IIc. Tested according to UL94 "Standard Tests for Flammability of Plastic Materials for Parts in Devices and Appliances" classification 94 HB for 3.2 and 1.6 mm thickness of the body. Tested according to DIN 4102 "Fire Behavior of Building Materials and Parts" classification materials class B-2. For further requirements, please consult igus® for special solutions, such as materials with self-extinguishing properties (UL94-V2 or UL94-V0). All e-chains® (except for the easy chains® and Series 14) are made of from igumid G.

## Flammability of igumid NB

All easy e-chains® and Series 14, F17 e-chains® are made from the flame-retardant igumid NB material. These e-chains® have the following flame-retardant classifications:

- UL94 classification - V2
- VDE 0304 Parts 3-5.70 classification - IIb
- DIN 4102 flammability of materials - B2
- Please consult igus® for material availability of V0

## Temperature resistance

igumid G / GLW is very suitable for outdoor applications. In our experience, the mechanical properties of the e-chain® are not impaired. igumid G / GLW is also UV-resistant. igus® e-chains® are used in applications as cold as -40°C (40°F). Installation may be eventually compromised at temperatures below -25°C (-13°F). In such cases, we offer special solutions made from cold-elastic materials. 100°C (212°F) continuous temperatures are possible. However, the mechanical values are reduced and the service life is impaired.

## Resistance to radiation

igus® offers several solutions for high-radiation areas. igumid G / GLW is very resistant to high-energy radiation. Under gamma radiation, in the range of  $8 \times 10^4$  rd, the mechanical properties of igumid G / GLW change very little. Please consult igus®.



Series 4040R rol e-chain® on a coal unloading system - Travel 190 m, Speed 0.5 m/s, Fill weight 8.05 kg/m



Live broadcast from the Winter Olympics in Lillehammer - 75 m travel at -25°C (-13°F)



### Flammability class

- **igumid G / GLW:**  
UL94-HB (Standard)
- **igumid NB:**  
UL94-V2 (Standard)  
UL94-V0 (upon request)



### igumid G / GLW:

- UV-resistant!
- Temperature range from: -40°C (40°F) up to +100°C (212°F)



● **ESD** - Avoidance of static charges in the field of manufacturing processes of electronic components or assemblies

● **ATEX** - Prevention of explosive static charge in hazardous environment

# Technical Environment | ESD & ATEX

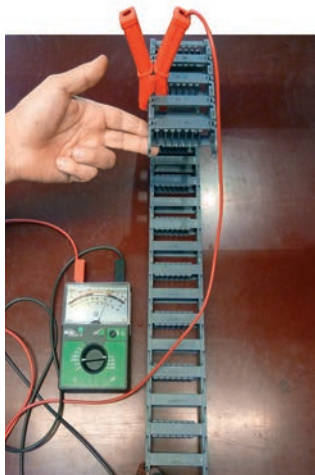

**100% of the produced ESD e-chains® are checked for their continuous conductivity "from one end to the other"**

Measurements of the electrical surface leakage resistance for igus® e-chains® with the special material igumid GC were made already in 1992 by the igus® GmbH together with the PTB (Physikalisch-Technische-Bundesanstalt) in Braunschweig, supplemented by additional certifications in 1998 and 1999 according to DIN 53482 and the guidelines for static electricity "ZH1/200" of the Federation of Trade Associations. In the course of further innovation, the material igumid ESD was certified by the PTB (Physikalisch-Technische-Bundesanstalt) in May 2002. The material igumid ESD combines in its properties the requirements of the ESD as well as ATEX criteria. In some mechanical requirements, the igumid ESD surpasses even the standard material igumid GLW and has been tested with over 10 million cycles in the igus® technology center.

## Your benefits with ESD products

- ESD material tested with over 10 million cycles for the highest requirements
- Snap-open e-chains® with mounting brackets and interior separation in ESD and ATEX design available from stock
- Standardized product - igumid ESD with PTB certificate
- Proven over years of use in explosion-proof areas
- Short delivery times: 08.00 - 20.00 h - ordering and delivery service



**Delivery program of ESD e-chains® from stock:**

### zipper

07 Bi 10 - 50 mm

09 Bi 16 - 50 mm

### E2/000

1500 Bi 15 - 80 mm

2500 Bi 25 - 125 mm

2700 Bi 50 - 125 mm

### E4.1

E4.21 Bi 30 - 70 mm

E4.28 Bi 40 - 125 mm

E4.32 Bi 50 - 200 mm

E4.42 Bi 50 - 200 mm

E4.56 Bi 75 - 300 mm

E4.80 Bi 75 - 300 mm

## Conductivity of igus® products from igumid ESD

In contrast to temporarily acting applied conductive surface coatings or volatile incorporated antistatic agents, the used additives grant a long lasting and maintenance-free conductivity. An e-chain® is not sufficient to ensure sufficient conductivity, if only the individual components exhibit conductivity, but the whole e-chain® from one to the other end must have a continuous conductivity. All products in this catalog are optimized in this regard and the continuous conductivity is measured and documented prior to delivery by a 100% test.

Only e-chains® that have passed this test are provided with the test seal and delivered. Color\* of igumid ESD products: similar to RAL7015, slate-gray to secure distinguishability with standard materials. (\*Exception: Cover zipper e-chains® series 07/09 - here black in color)



**Available from stock.**  
**Delivery in 24h or today!**  
Delivery time means time until shipping of goods (after technical release)

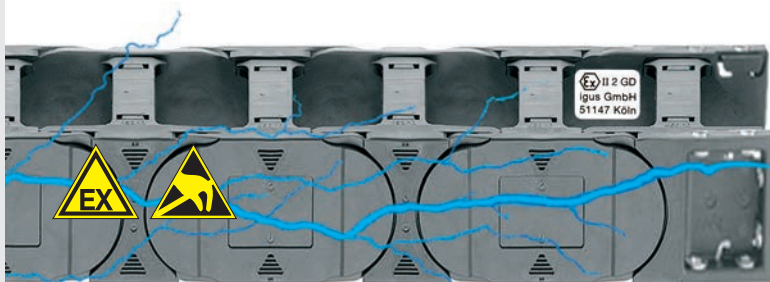



Further information for igus® ESD e-chains® - classification: Ex II 2 GD

● **General safety information:** These additional Operating Instructions apply to the explosion-protected versions of our e-chains® of Type "ESD" in color gray (similar to RAL 7015). They supplement the Installation Instructions for the standard e-chains® and the catalog information. The information in these instructions relates only to data impacting on explosion protection. The technical information in the Installation Instructions for the standard e-chains® and the category information still apply unchanged unless these Instructions explicitly exclude or replace the relevant information. Required documentation and other documents are filed with the following institute pursuant to the ATEX Directive:

**Physikalisch-Technische Bundesanstalt (PTB) Braunschweig and Berlin**  
 Bundesallee 100 • 38116 Braunschweig/Germany

● **Assembly, removal and installation:** Please follow the information in the Installation Instructions for the standard e-chains® and the catalog information on assembly, removal and installation for trouble-free operation. igus® ESD e-chains® must be grounded with appropriate measures in accordance with drawing number: 18392.2 in order to discharge any electrostatic charges occurring.

**Assembly, installation, commissioning and maintenance may be performed only by "personnel trained in explosion protection"!**

Please also note the corresponding national safety regulations and the relevant national regulations in respect of explosion protection during assembly and operation.

● **Commissioning:** Before commissioning the system, check that the system has been installed correctly in accordance with the Installation Instructions for the standard e-chains® and the catalog information. Correct grounding must be checked in particular in the case of ESD e-chains®.

● **Maintenance:** igus® e-chains® are maintenance-free. Correct grounding of the e-chains® must be inspected at regular intervals. (\*in case of large projects a customized maintenance plans can become an issue and will be created if necessary)

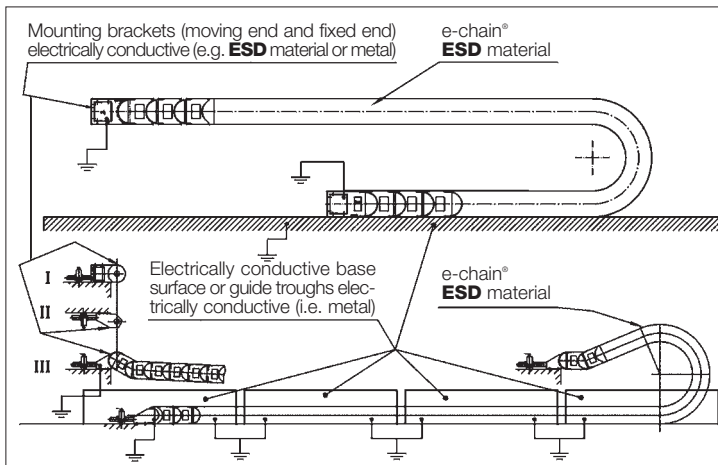

Connection of an e-chain® in accordance with ATEX Directive 94/9/EC



**igusid G/GLW:** Ex II 3 GD

igus® e-chains® made of standard material igumid G/GLW correspond to the German federal office of Physics and Technology (PTB) to classification Ex II 3 GD according to ATEX-RL 94/9/EG.

**igusid ESD:** Ex II 2 GD

igus® e-chains® made of igumid ESD correspond according to the German federal office of Physics and Technology (PTB) to classification Ex II 2 GD according to ATEX-RL 94/9/EG



**igus® igumid ESD with PTB certificate**

We have received an official certificate from the German National Standards Laboratory (PTB) on material igumid ESD and we are able to provide you with a copy on request.



Order separate catalog for igus® ESD e-chains® or find the full program online ► [www.igus.eu/eu/esd](http://www.igus.eu/eu/esd)

# Technical Environment | Clean Room and ESD

## Safe and clean with e-chains®

### igus® goes clean room - qualification of E6 and other igus® e-chains®

In many applications where cumbersome special solutions are used, a simple standard e-chain® can be used instead. A comprehensive test program was devised and performed for both gliding use and unsupported use. For many applications, the e-chains® in special materials are practically abrasion-free. Detailed test results are available upon request. IPA tests confirm that standard igus® e-chains® meet clean room requirements. "Tested and certified as very good!" e-chains® for clean room applications in the test stand Clean room environments demand very high wear resistance of moving parts. e-chains®, for example, must be very wear resistant, in order to meet normal requirements for such a sensitive environment.

#### IPA Fraunhofer Institute has tested igus® Series E3, E6 and easy chain® as follows:

- ISO class 1, as per stringent norm DIN EN ISO 14644-1 for System E3, Series E3.15.040.075.0 at v = 0,5 m/s, 1 m/s, 2 m/s
- ISO class 1, as per stringent norm DIN EN ISO 14644-1 for System E6 - special material\*, Series E6.29.060.150.0.CR at v = 0,5 m/s, 2 m/s
- ISO class 3, as per stringent norm DIN EN ISO 14644-1 for System E6 - standard material, Series E6.29.060.150.0 at v = 0,5 m/s, 1 m/s, 2 m/s
- ISO class 2, as per stringent norm DIN EN ISO 14644-1 for Series easy chain® E14.3.038 at v = 1 m/s

Class per DIN EN ISO 14644-1	Equivalent to VDI 2083	Equivalent to US Fed.Std. 209E	Classification Series	Report Number	Speed [m/s]
ISO Class 1	no comparable classification	no comparable classification	E3.15.040.075.0	IG0704-400	0,5 / 1,0 / 2,0
ISO Class 1	no comparable classification	no comparable classification	E6.29.060.150.0.CR*	IG0704-400	0,5 / 2,0
ISO Class 2	no comparable classification	no comparable classification	E14.3.038.0	IG0308-295	1,0
ISO Class 3	Class 1	Class 1	E6.29.060.150.0	IG0704-400	0,5 / 1,0 / 2,0
ISO Class 4	Class 2	Class 10			
ISO Class 5	Class 3	Class 100			
ISO Class 6	Class 4	Class 1.000			
ISO Class 7	Class 5	Class 10.000	*special material "clean room"		
ISO Class 8	Class 6	Class 100.000			



### Particle generation measurement



Result: Particle generation  
E14.3.038.0

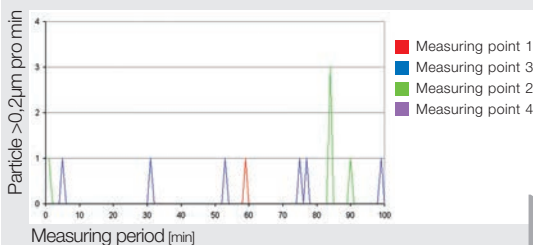

### ISO Class 2

acc. DIN EN ISO 14644-1 for E14.3.038.0



**Absorption LEVEL 1** confirmed by IPA-Fraunhofer-Institut according to SEMI E78-0998 for the E6 standard material. Continuously constant conductance value as there are no pin-bore connection (no air gaps).

### Field strength measurement



Result: Field strength  
E6.29.050.055.0

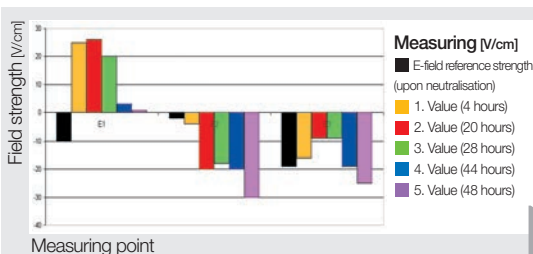

### Level 1

ESD-compatibility acc. to SEMI E78-0998 for E14.3.038.0 and E6.29.050.055.0

## Spatter, hot chips

Laboratory tests and numerous field applications have proved that igus® e-chains® and e-tubes reliably protect cables in welding robots and machine tools since 20 years. e-tubes made from the igus® igumid HT material are resistant against hot chips up to 850°C (1,562°F), no chips stick. This opens new possibilities for replacing more complex and expensive steel tubes. Product range: All standard E2 and E4 e-tube sizes, upon request. Please note: igumid G / GLW in direct contact with large amounts of melted aluminum is not recommended.

## Dirt, dust, chips

Materials and design make igus® e-chains® excellent problem-solvers in harsh environments. Experience and application references are available upon request. Please consult igus® with your application.

## Vacuum

igus® e-chains® made of igumid G / GLW can be used in vacuum applications. Very little outgassing occurs.

## Chemical resistance

igumid G / GLW is resistant to fuel, lubricants, oils, fats, alcohol, ester, ketone, and aliphatic and aromatic hydrocarbons. Oxidants and acids are damaging. The table ► **page 127** shows an excerpt of the precise details concerning resistance to chemicals. Acid-resistant e-chains® are available upon request.

## Coolant resistance

e-chains® and e-tubes have proven resistant to cooling agents. However, we are always willing to perform individual tests if you have particular problems or advanced developments.

**Table on resistance to chemicals ► page 127**



igus® e-tubes in the chip area of machine tools



Also hot asphalt is no problem for igus® e-tubes



System E4 in an incinerating plant - safe also in abrasive dirt and dust



Compost sludge - numerous related references available upon request



**igus® - Experience with:** Dust, dirt, mud, compost, wood, textile fibers, paper dust, abrasive paste, cooling agents, glass dust, glass splinters, coal dust, sand, carborundum and much more.



e-tubes that repel hot chips, up to 850 °C with the igus® "igumid HT" material. ► [www.igus.eu/eu/HT](http://www.igus.eu/eu/HT)

## Material data igumid

Material data table	Units of measure	Values igumid G/GLW	Values igumid NB	Values igumid ESD	Values igumid TE	Values igumid GE
<b>Mechanical properties</b>						
Yield stress (dry/wet)	MPa	190/130	78/40	*	*	*
Elongation at break (dry/wet)	%	004/006	20/210	*	*	*
Elasticity module (tensile test)	MPa	9000/7000	2900/1200	*	*	*
Limit of elasticity (bending)	MPa	7.800 <sup>1)</sup>	3.000 <sup>1)</sup>	9.500 <sup>1)</sup>	1.290 <sup>1)</sup>	7200 <sup>1)</sup>
Bending strength	MPa	240 <sup>1)</sup>	120 <sup>1)</sup>	230 <sup>1)</sup>	55 <sup>1)</sup>	200 <sup>1)</sup>
Hardness Shore D	–	79 <sup>1)</sup>	79 <sup>1)</sup>	83 <sup>1)</sup>	72 <sup>1)</sup>	80 <sup>1)</sup>
<b>General properties</b>						
Density	g/m <sup>3</sup>	1,37	1,14	1,2	1,02	1,46
Absorption of humidity 23/50 RF	% by weight	1,4	3,4	1,9	0,8	0,7
Max. water absorption	% by weight	5,6	7,6	7,3	1,6	4
<b>Electical properties</b>						
Specific transitional resistance	Ω*cm	>10 <sup>11</sup>	>10 <sup>11</sup>	<10 <sup>9</sup>	>10 <sup>11</sup>	>10 <sup>11</sup>
Surface resistance ROA	Ω	>10 <sup>11</sup>	>10 <sup>11</sup>	<10 <sup>9</sup>	>10 <sup>11</sup>	>10 <sup>11</sup>
<b>Thermal properties</b>						
Lower application temperature	°C / °F	-40°C / -40°F	-40°C / -40°F	-40°C / -40°F	-40°C / -40°F	-40°C / -40°F
Upper long-term application temp.	°C / °F	100°C / 212°F	80°C / 176°F	80°C / 176°F	70°C / 158°F	120°C / 248°F
Upper short-term application temp.	°C / °F	160°C / 320°F	170°C / 338°F	150°C / 302°F	140°C / 284°F	200°C / 392°F
<b>Material certificates</b>						
Fire resistance as per UL94	–	HB	V-2	HB	HB	HB
Silicone-free	–	yes	yes	yes	yes	yes
Halogen-free	–	yes	yes	yes	yes	no
2002/95/EG (RoHS)	–	yes	yes	yes	yes	yes
2002/96/EG (WEEE).	–	yes	yes	yes	yes	–
<b>Color</b>						
acc. to RAL, approx.	–	■ ≈RAL9004	■ ≈RAL9004	■ ≈RAL7015	■ ≈RAL9004	■ ≈RAL9004











<sup>1)</sup>Values upon request



## Colors and special solutions

Product prices are always based on the color black. e-chains® in any color shown in the color selection chart are subject to a percentage based color surcharge. Any other colors that are not shown in the chart are individually calculated depending on the article and quantity, insofar as this is technically possible. As a rule, colored e-chains® are not available from stock. Delivery lead-time and surcharges for colored e-chains® are available upon request. As a rule, all specifications related to stability (for instance unsupported lengths) and material characteristics apply only to black e-chains®. The characteristics of colored e-chains® may differ. This also applies to all e-chains® from special materials, such as conducting e-chains® made from igumid ESD material or other special materials. For technical reasons HT and ESD materials cannot be supplied in other colors.

### e-chain® color variations with RAL-numbers

 <b>Black</b>	Standard, from stock!	≈ RAL 9004	<b>Index .0</b>	 <b>White</b>	special color	≈ RAL 9003	<b>Index .1</b>
 <b>Slate grey</b>	ESD material only	≈ RAL 7015	<b>Index .ESD</b>	 <b>Gray white</b>	special color	≈ RAL 9002	<b>Index .1S</b>
 <b>Gray brown</b>	HT material only	≈ RAL 8019	<b>Index .HT</b>	 <b>Orange</b>	special color	≈ RAL 2003	<b>Index .2</b>
 <b>Gray</b>	special color, e-chains® only	≈ RAL 7023	<b>Index .3</b>	 <b>Yellow</b>	special color	≈ RAL 1018	<b>Index .4</b>
 <b>Dusty Gray</b>	special color, e-tubes only	≈ RAL 7037	<b>Index .31</b>	 <b>Light grey</b>	special color	≈ RAL 7035	<b>Index .14</b>



**Black e-chains® available from stock! Delivery time\* for special colors: from 5 work days.**

\*Delivery time means time until shipping of goods (after technical release)



## Chemical Resistance of igumid

Medium	Konzentration	igumid	igumid
	Gewicht %	G / GLW / NB	TE
Acetone	100	+	+
Formic acid (aqueous)	2	O	+
Ammonia (aqueous)	10	+	+
Gasoline	100	+	+
Benzole	100	+	+
Bitumen	100	O	-
Boric acid (aqueous)	10	+	O
Butyric acid	100	O	-
Calcium chloride (aqueous)	Sat. aq. sol.	+	+
Chlorinated hydrocarbons		+	O
Chlorine water	Sat. aq. sol.	-	-
Chromic acid (aqueous)	1	O	-
Diesel oil	100	+	+
Acetic acid	2	+	O
Color		+	+
Fats, cooking		+	+
Fluorinated hydrocarbons		+	+
Formaldehyde (aqueous)	30	O	O
Hydraulic oils		+	O
Caustic potash	10	+	+
Potassium carbonate (aqueous)	60	+	+
Potassium sulphate (aqueous)	100	+	+
Methyl acetate	100	+	+
Milk		+	+
Mineral oil		+	+
Sodium carbonate (aqueous)	50	+	+
Oil, cooking		+	+
Oil, lubricating oil		+	+
Oleic acid	100	+	+
Paraffin oil		+	+
Perchlorethylene	100	+	-
Polyester resins (with styrene)		+	+
Propane gas		+	+
Mercury		+	+
Hydrochloric acid	pH2	O	-
Hydrochloric acid	2	-	-
Hydrochloric acid	10	-	-
Ink, printing ink		+	+
Vaseline		+	+
Tartaric acid		O	+
Zinc sulfate (aqueous)	10	+	-



The values specified are values determined by laboratory tests and are material-specific. All specifications apply to black e-chains®.

### Resistance classes

+ = resistant

O = conditionally resistant

- = non-resistant

Sat. aq. sol. = saturated aqueous solution

# Certifying | Standards and Certificates



Quality inspection of every e-chain® production



Test location for ESD-e-chains®



chainflex® cables with many certificates for e.g. DESINA



Noise level tests in igus® own acoustic laboratory

## DIN EN ISO 9001:2008 and ISO/TS 16949:2009

igus® is certified in accordance with DIN EN ISO 9001:2008 and ISO/TS 16949:2009 in the field of energy chains® with cables and harnessing, as well as plastic pin bearings.



## TÜV construction test

igus® e-chains® and e-tubes are construction-tested by TÜV Rheinland. igus® e-chains® were tested and passed by TÜV Rheinland in accordance with the valid machine guidelines. As a result, the user of igus® e-chains® need not worry about meeting CE requirements through testing for this portion of the machinery. **The construction test 2PFG 1036 / 10/97 for protective equipment includes the following:** ● Application and safety ● Assembly ● Fatigue strength ● Resistance to external influences ● Sharp corners and edges



## ESD/ATEX

igus® e-chains® made of standard material igumid G/GLW correspond to the German federal office of Physics and Technology (PTB) to classification Ex II 3 GD according to ATEX-RL 94/9/EG. igus® e-chains® made of igumid ESD correspond according to the German federal office of Physics and Technology (PTB) to classification Ex II 2 GD according to ATEX-RL 94/9/EG.



## IPA Cleanroom

A lot of e-chains® are suitable for the use in cleanrooms according to DIN EN ISO 14644-1. Confirmed by the IPA Fraunhofer Institute.



## UL, CSA, CEI, CE and VDE

All igumid-materials for e-chains® and e-tubes have got the UL-material approval. The material igumid NB has got the fire protection class approval IIb according to the test VDE 0304 Part 3/5.70, the approval V2 according to UL94 and the construction material class B2 according to DIN 4102.



## Interbus, CC-Link and DESINA

chainflex® - cables are produced according to a lot of international standards: **Interbus certification:** For Interbus certification of certain CF11 bus cables. **CC-Link:** CC Link is a Fieldbus established by Mitsubishi Electric Automation. igus® chainflex® CFBUS035 is CC Link certified. **DESINA:** Many chainflex® cables are Desina-compliant.



## Clearly quieter

igus® e-chainsystems® are clearly quieter. In the acoustic laboratory of the TÜV and the igus® GmbH different e-chains® were compared (see also noise-optimized e-chains® ► page 91).



## igumid

The material igumid is free from toxins, according to 2002/95/EC (RoHS).

## iF Design Award

26 iF Design-Awards since 1987 ► [www.igus.eu/IF](http://www.igus.eu/IF)



# igus<sup>®</sup> readychain<sup>®</sup>

Ready made e-chainsystems<sup>®</sup>

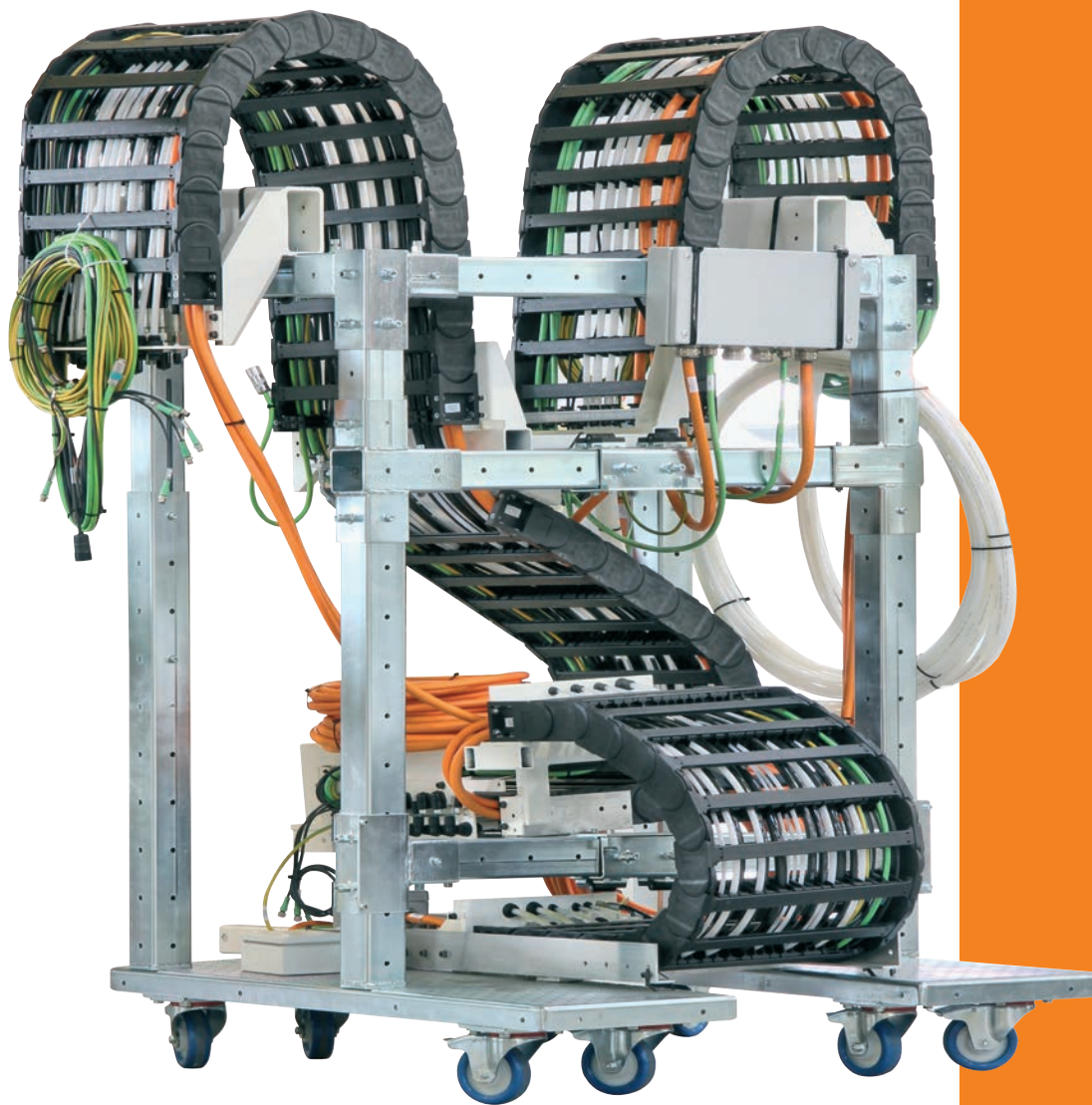

readychain® | We do it immediately...

...for your capacity increase...



3 shifts, 137 staff members, 13 project engineers, 500 orders/week on more than 3000 m<sup>2</sup>...

...for your Cash-flow...



...in the extended harnassing factory.

## You determine the degree of harnessing



**Any degree of harnessing is possible**  
 We harness from simple e-chainsystems® with inserted chainflex® cables to complex systems. These systems may include all cables and hoses (pneumatic, hydraulic), patch plugs, inner partitions, connecting elements and connecting parts as requested.

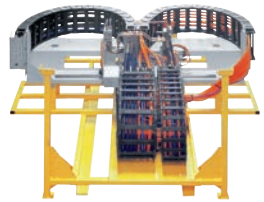

From easy ..... to project

## You determine the size



**Any size is possible**  
 Because of our up-to-date production processes we can deliver fast and cheap custom-build or serial production products.



From batch size 1 ..... to serial production

## You determine the travel



**Choosing the travel**  
 readychains® offers the whole spectrum of possible travels of the igus® e-chains®. We harness anything from extremely short to long travels. Safe transportation guarantees damage-free delivery of all lengths.



From short ..... to long travel

## Standardized readychain® packages help you get started

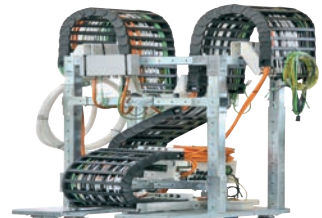
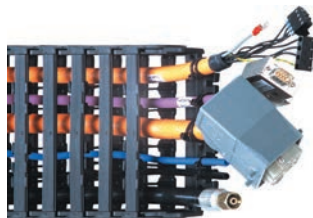
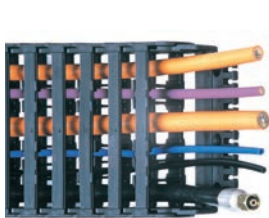

 readychain® "Basic"  
 Delivery time\*: 3 days

 readychain® "Standard"  
 Delivery time\*: 3-5 days

 readychain® "Premium"  
 Delivery time\*: 10 days

\*Delivery time means time until shipping of goods (after technical release)

## readycable® - harnessed cables in 24h-48h or today

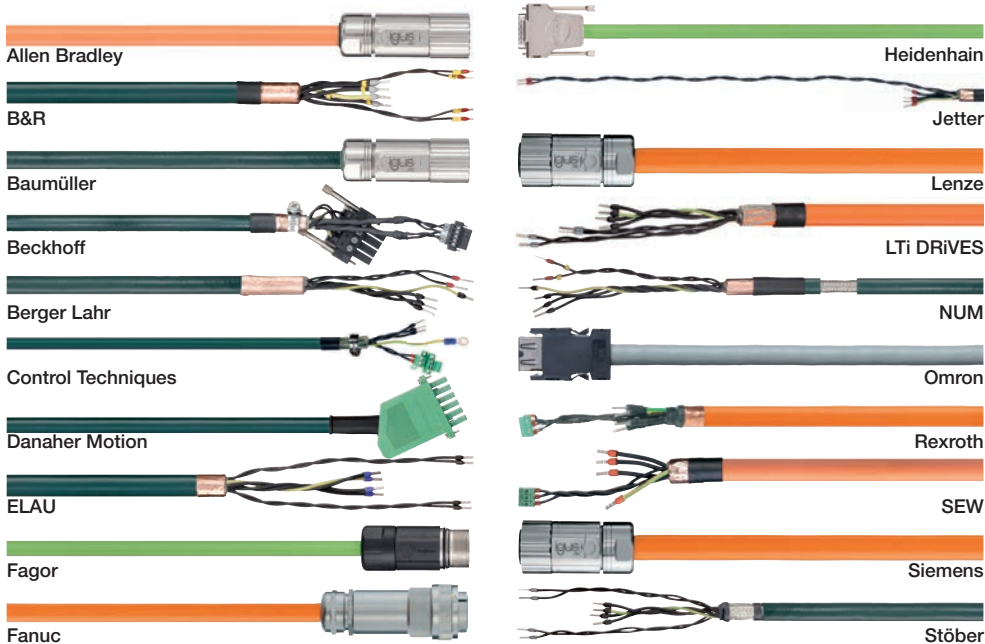

- igus® offers over 2.830 defined drive cables according to 20 different manufacturers standards
- Servo, power and signal/encoder cables
- No cutting costs and no surcharges for small quantities and packaging
- Cable length up to the centimeter to customer
- Smallest bending radii from 7,5 x d
- Reduce storage costs and increase cash flow

## Professionally produced and 100% tested



### QuickPin 2.0

Connector-Cable-Configurator  
with integrated EPLAN P8.

► [www.igus.eu/eu/quickpin](http://www.igus.eu/eu/quickpin)

# Ready made | Modular...quick...and ready to install

## Everything from one source

1

The readychain® system includes pre-assembled, customized energy chain systems\*. The "plug in and ready" solutions are configured, manufactured and delivered according to individual customer specifications. The use of the mounting rack can yield benefits even at low volumes.



2

## Flexible components

The telescoping supports and braces of the readychain® rack allow flexible adaptation to the installation situation on site. Changes in mass production can be undertaken easily. By the latching mechanism, additional components can also be easily attached to the rack subsequently.

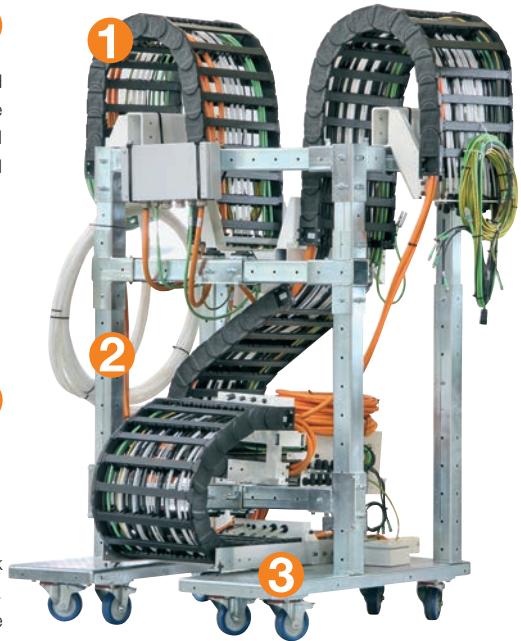

## readychain® rack

Your guide to reduced processing costs -  
Achieve your target in hours instead of days  
with the new modular transport rack from igus®

## Sustainable use

3

The components of the readychain® rack are galvanized and thus designed for a long life. Each rack is constructed within a few hours. The individual elements can be reused at any time removing the need to dispose of custom made parts, as with conventional welded transport racks.

## Precise fitting "Plug & Play"

4

All interfaces and attachments are designed in such a way that the installation of the e-chain® can be managed quickly and easily. The complete package includes the matching plugs and connectors, plates, sensor actuator boxes, linear bearings, links to the central lubrication, etc., all reducing the installation time considerably.



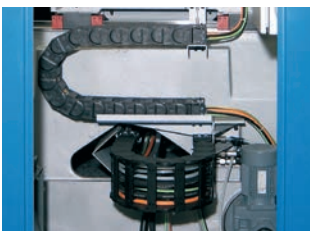

**We invite you!** Visit us in Cologne and learn more about our factory, order management, sales, planning and production.



**Christian Stremmlau**  
Manager readychain® systems  
Tel. +49(0)2203/9649-273  
E-Mail: cstremmlau@igus.de



 Find a video online ►  
[www.eu/eu/.readychain](http://www.eu/eu/.readychain)





readychain®-factory in Cologne, Germany more than 3,000 m<sup>2</sup> (orange shaded)



**11 readychain® factories worldwide:**

- readychain® factories
- igus® subsidiaries
- certified partners

- ① igus® Cologne
- ② igus® Brasil
- ③ igus® China
- ④ igus® India
- ⑤ igus® Italy
- ⑥ igus® Japan

- ⑦ igus® South Africa
- ⑧ igus® South Korea
- ⑨ igus® Spain
- ⑩ igus® UK
- ⑪ igus® USA

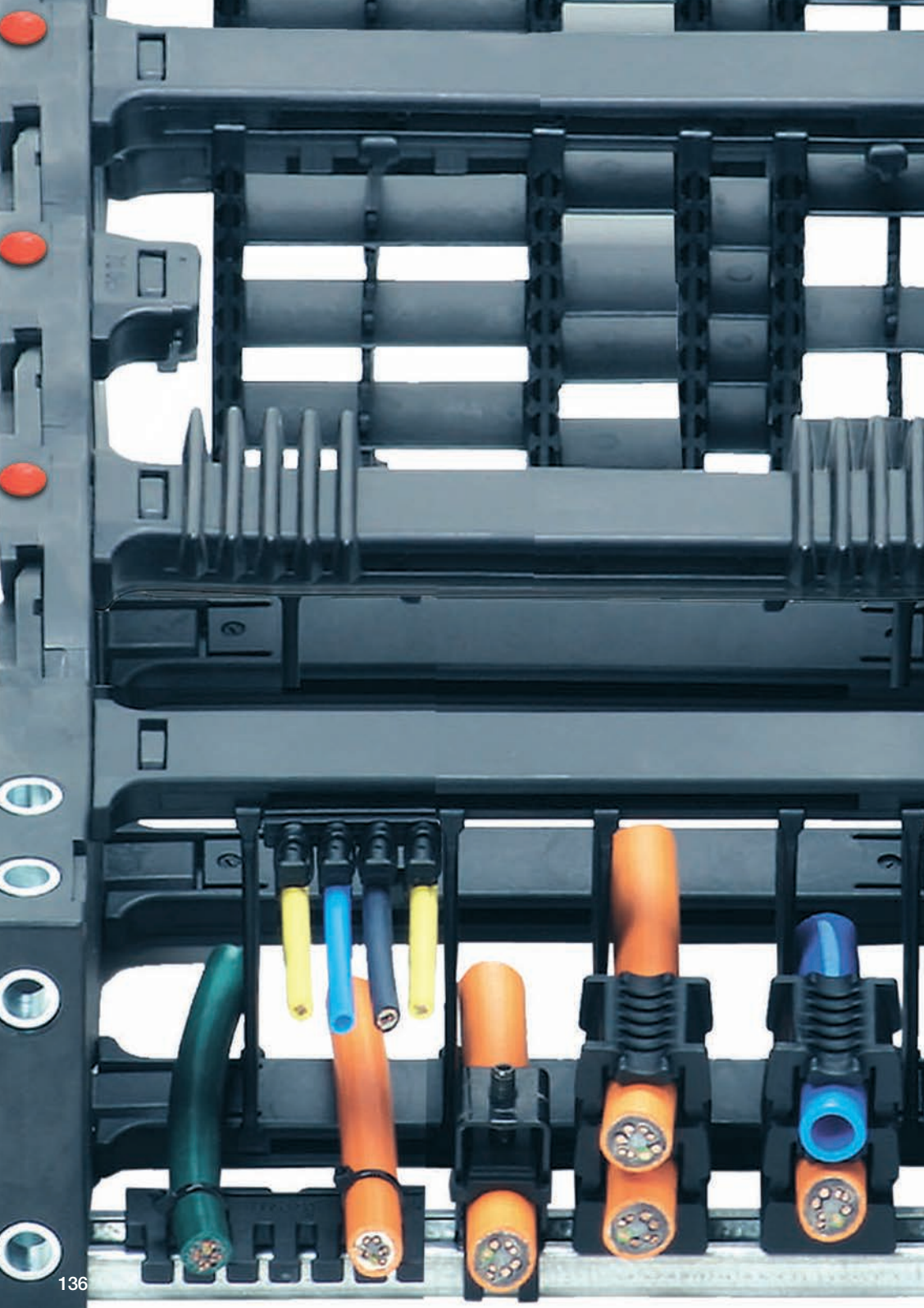

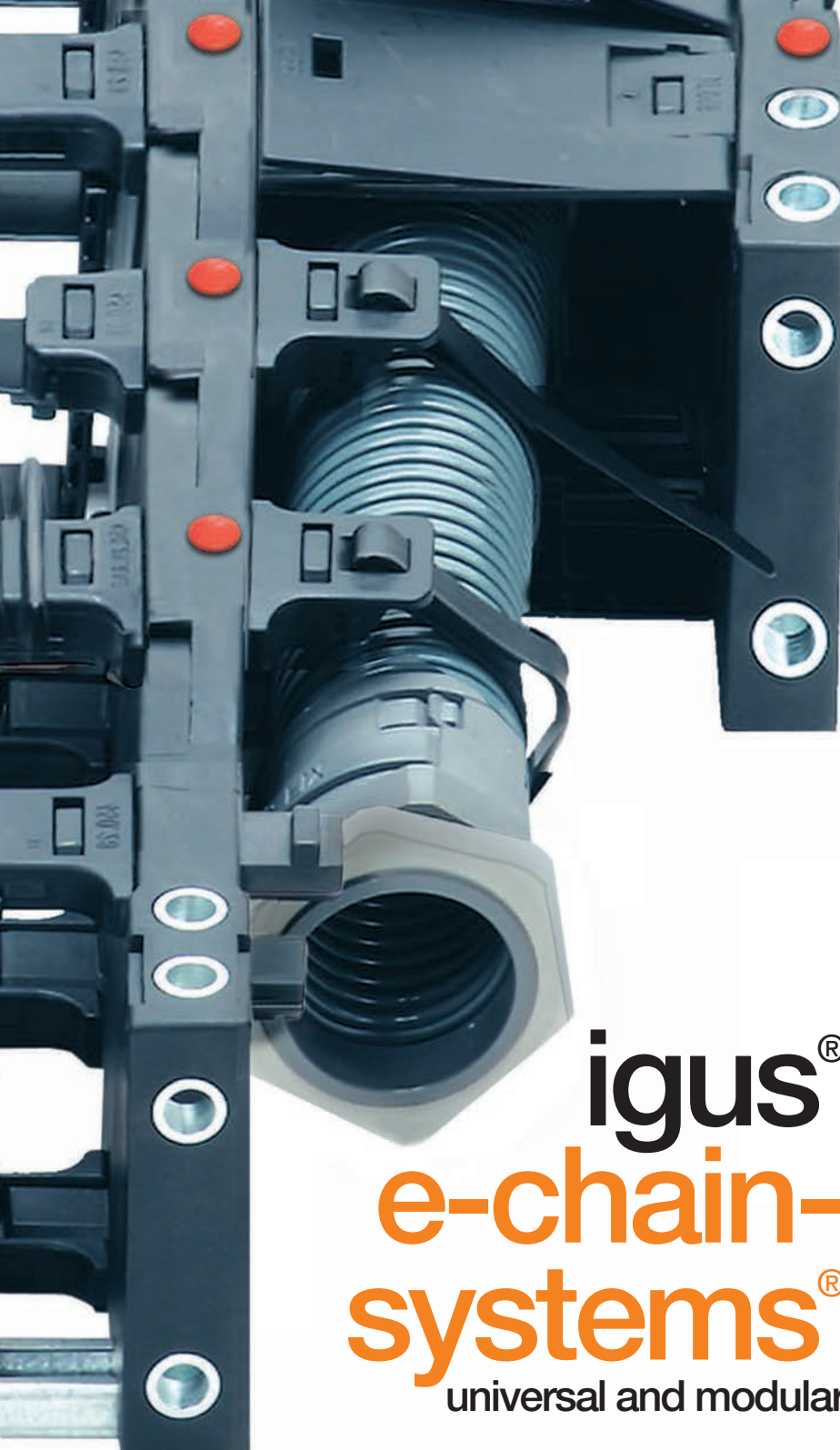

# igus<sup>®</sup> e-chain- systems<sup>®</sup>

universal and modular

clean room

system E4

E2 e-tubes

system E2

zipper

easy chain<sup>®</sup>

Universal:  
Mounting bracket with  
strain relief option

Save time:  
Simply press cables in  
without opening and  
closing crossbars

Flexible:  
Easy to lengthen and  
shorten at any point

Keep order:  
Interior separation possible  
with moulded in chamber  
systems (some types)

Cost effective:  
Low price with  
one-piece design

Clean room:  
Suitable for clean-  
room applications

Flexible:  
Torsional motions possible

Certification:  
UL94-V2 classification

# easy chain® - easy to fill and very cost effective

easy chains® are available with exterior (version E) press fit access, as well as interior (version Z) access. The assembly time reductions are a primary reason to choose easy chains®. Their material, igumid NB, presents more application opportunities with: Optimal elasticity, UL94-V2 classification and excellent clean room qualities. Their one-piece design keeps the easy chain® very price-effective

## Typical industries and applications

- General machinery
- Clean room applications
- Electronic apparatus
- Office equipment
- Vending machines
- Packaging machines
- Machine tools



## Clean room test acc. to Fraunhofer Institute IPA

Standard material - ISO Class 2 acc. to ISO 14644-1

Speed:  $v = 1,0 \text{ m/s}$  and  $a = 2,0 \text{ m/s}^2$  - Series E14.3.038



Electrically conductive  
ESD/ATEX versions upon request



With easy chain® rotatory and  
torsional motions are possible











42 dB(A) - Value determined at the igus® test-  
lab:  $v = 1,0 \text{ m/s}$  unsupported, Series E06.10.038.0



UL94-V2  
classification



# easy chain® | Selection Table

Series		Inner height	Inner width	Outer width	Outer height	Bending radius	Unsupported length	Page	
		<i>hf</i> [mm]	<i>Bi</i> [mm]	<i>Ba</i> [mm]	<i>ha</i> [mm]	<i>R</i> [mm]	max. length [m]		
 <p><b>easy chain® - Version "E"</b> simply press cables in</p> <p>Split crossbar along the outer radius</p>									
1-chamber	E03	5	5 - 10	8,7 - 13,7	8	10 - 28	0,40	142	
	 E04	7	7	13	10	15 - 48	0,55	144	
	E045	9,4	10 - 16	16 - 23	12,5	18 - 38	0,40	146	
	E06	10,7	10 - 20	16,5 - 26,5	15	18 - 38	0,55	148	
	E065	11,3	16	24,8	15	18 - 38	0,60	150	
	E08	14,6	10 - 50	18,2 - 58,2	19,3	28 - 48	1,00	152	
	E14	19	15 - 50	27 - 62	25	28 - 125	0,65	154	
	E200	24,3	57	74,4	35	55 - 200	1,75	156	
	E16	32	23 - 100	37,5 - 115,3	39	60 - 100	1,00	158	
	E26	36,5	75	92	50	63 - 250	2,00	160	
E300	48,5	75	95	64	75 - 300	2,25	162		
2-chamber	E045.2	9,4	7 - 9	23 - 27	12,5	18 - 38	0,40	146	
	 E065.2	11,3	9	29,3	15	18 - 38	0,60	150	
	E200.2	24,3	37 - 50	94,4 - 120,4	35	55 - 200	1,75	156	
	E26.2	37,1	48	117	50	63 - 250	2,00	160	
	E300.2	48,5	48	120	64	75 - 300	2,25	162	
3-chamber	E045.3	9,4	9	37	12,5	18 - 38	0,40	146	
	 E065.3	11,3	9	39,3	15	18 - 38	0,60	150	
	E26.3	37,1	47	167	50	63 - 250	2,00	160	
E300.3	48,5	46	170	64	75 - 300	2,25	162		
4-chamber	E065.4	11,3	9	49,3	15	18 - 38	0,60	150	
 <p><b>easy chain® - Version "Z"</b> simply press cables in</p> <p>Split crossbar along the inner radius</p>									
1-chamber	Z045	9,4	16	23	12,5	18 - 38	0,40	146	
	 Z06	10,5	10 - 20	16,5 - 26,5	15	18 - 38	0,55	148	
	Z08	14,6	10 - 50	18,2 - 58,2	19,3	28 - 48	1,00	152	
	Z14	19	15 - 50	27 - 62	25	28 - 125	0,65	154	
	Z200	24,3	57	74,4	35	55 - 200	1,75	156	
	Z16	32	23 - 100	37,5 - 115,3	39	40 - 100	1,00	158	
	Z26	36,5	75	92	50	63 - 250	2,00	160	
	Z300	48,5	75	95	64	75 - 300	2,25	162	
	2-chamber	Z045.2	9,4	16	23	12,5	18 - 38	0,40	146
		 Z200.2	24,3	37 - 50	94,4 - 120,4	35	55 - 200	1,75	156
Z26.2		37,1	48	117	50	63 - 250	2,00	160	
Z300.2		48,5	48	120	64	75 - 300	2,25	162	
3-chamber	Z045.3	9,4	9	37	12,5	18 - 38	0,40	146	
	 Z065.3	11,3	9	39,3	15	18 - 38	0,60	150	
	Z26.3	37,1	47	167	50	63 - 250	2,00	160	
E300.3	48,5	46	170	64	75 - 300	2,25	162		

## Technical Data



Gliding speed / acceleration (maximum) max. 3 [m/s] / max. 10 [m/s<sup>2</sup>]

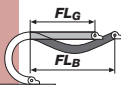

Speed / acceleration  $FL_G$  max. max. 20 [m/s] / max. 200 [m/s<sup>2</sup>]

Speed / acceleration  $FL_B$  max. max. 3 [m/s] / max. 6 [m/s<sup>2</sup>]



e-chain® material - permitted temperature °C, igumid NB -40° up to +80° C

Mounting brackets\* material - permitted temperature °C, igumid G -40° up to +120° C



Flammability class: igumid NB = VDE 0304 IIC UL94-V2 / igumid G = VDE 0304 IIC UL94-HB









■  $FL_G$  = with straight upper run ■  $FL_B$  = with permitted sag

\*Available in igumid NB upon request, please consult igus® for delivery time

## Installation methods overview, maximum travels

e-chain® Series	Unsupported application	Vertical hanging	Vertical standing	Side mounted unsupported	Rotary application	Zig-zag application
E03	≤ 0,40 m	upon request	upon request	upon request	with rework	upon request
E04	≤ 0,55 m	upon request	upon request	upon request	with rework	upon request
E045/Z045	≤ 0,40 m	upon request	upon request	upon request	with rework	upon request
E06/Z06	≤ 0,55 m	upon request	upon request	upon request	with rework	upon request
E065/Z065	≤ 0,60 m	upon request	upon request	upon request	with rework	upon request
E08/Z08	≤ 1,00 m	upon request	upon request	upon request	with rework	upon request
E14/Z14	≤ 0,65 m	upon request	upon request	upon request	with rework	upon request
E200/Z200	≤ 1,75 m	≤ 10 m	≤ 1,5 m	≤ 0,5 m	with rework	upon request
E16/Z16	≤ 2,00 m	≤ 10 m	≤ 1,5 m	≤ 0,5 m	with rework	upon request
E26/Z26	≤ 2,00 m	≤ 10 m	≤ 1,5 m	≤ 0,5 m	with rework	upon request
E300/Z300	≤ 2,25 m	≤ 10 m	≤ 1,5 m	≤ 0,5 m	with rework	upon request

## Options with order keys based on Series E200

 <p><i>Standard</i></p> <div style="border: 1px solid gray; padding: 5px; margin: 10px 0;"> <p>Part No. <b>Standard</b> e-chains®</p>  </div> <p> <b>E200.05.R.0</b></p>	<p><i>NC-Version - (no camber) without pretension</i></p> <div style="border: 1px solid gray; padding: 5px; margin: 10px 0;"> <p>Part No. <b>NC-Version</b> e-chains®</p> <p>NC</p>  </div> <p><b>E200.05.R.0.NC</b></p>	<p><i>Reverse bending radi- us for circular movements</i></p> <div style="border: 1px solid gray; padding: 5px; margin: 10px 0;"> <p>Part No. <b>RBR</b> e-chains®</p>  </div> <p><b>E200.05.R1/R2.0</b></p>	<p><i>ESD / ATEX classified e-chains®</i></p> <p> II 2 GD</p> <div style="border: 1px solid gray; padding: 5px; margin: 10px 0;"> <p>Part No. <b>ESD-Material</b> e-chains®</p>  </div> <p><b>E200.05.R.0.ESD</b></p>
<p> <b>Delivery from stock</b></p>	<p><b>Delivery time: upon request</b></p>	<p><b>Delivery time: upon request</b></p>	<p><b>Delivery time: upon request</b></p>

## Order example | Order key and color options based on Series E200

 **Order example for complete e-chain® (1,0 m), color black, with mounting brackets:**

e-chain® (1,0 m)	Please indicate e-chain® length or number of links: 1,0 m or 22 links	<b>E200.05.100.0</b>
<b>+ Mounting brackets</b>	1 set (+ tiwrap plates)	<b>2050.34PZB</b>
<b>Order text: 1,0 m E200.05.100.0 + 2050.34PZB</b>		

### Order key

Version "E" Split crossbar along outer radius	<b>E200.05.100.0</b>
Version "Z" Split crossbar along inner radius	<b>Z200.05.100.0</b>
Version "E" or "Z"	
Series / Type	
Width index (depends on <i>B</i> )	
Bending radius <i>R</i>	
Color index (standard black)	

### General igus® color options for e-chains® and e-tubes

Color	Order index	Color	Order index
<b>Black</b> Standard, from stock!	<b>.0</b>	<b>White</b> special color	<b>.1</b>
<b>Slate grey</b> only ESD material	<b>.ESD</b>	<b>Gray white</b> special color	<b>.1S</b>
<b>Gray brown</b> only HT material	<b>.HT</b>	<b>Orange</b> special color	<b>.2</b>
<b>Gray</b> special color only e-chains®	<b>.3</b>	<b>Yellow</b> special color	<b>.4</b>
<b>Dusty grey</b> special color only e-tubes	<b>.31</b>	<b>Light grey</b> special color	<b>.14</b>

**Black e-chains® available from stock!**  
**Delivery time for special colors: upon request**

**E200.05.100.0** = Version "E" - split crossbar along the outer radius, inner width *Bi* 57 mm, radius *R* 100 mm, color black  
**Z200.05.100.0** = Version "Z" - split crossbar along the inner radius, inner width *Bi* 57 mm, radius *R* 100 mm, color black



## Series E03 | Split crossbar along the outer radius

Split crossbar along outer radius	<i>Bi</i> [mm]	<i>Ba</i> [mm]	<i>R</i> Bending radii [mm]	Weight [kg/m]
E03.05 .R.0 <sup>1)</sup>	5	8,7	010   012   015   018   028	≈ 0,03
E03.07 .R.0 <sup>2)</sup>	7	10,7	010   012   015   018   028	≈ 0,04
E03.10 .R.0 <sup>2)</sup>	10	13,7	010   012   015   018   028	≈ 0,05

1) Crossbars do not overlap. Gap = 1 mm / 2) Crossbars do not overlap. Gap = 2 mm

Supplement Part No. with required radius (*R*) Example: E03.05.028.0

*Ba*: pin dimension approx. 0,1 - 0,3 mm wider.

## Dimensions

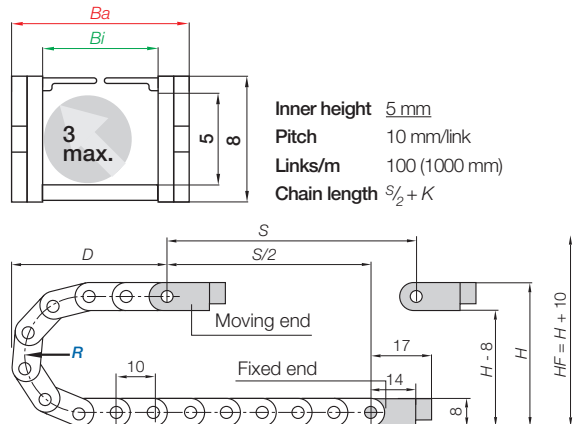
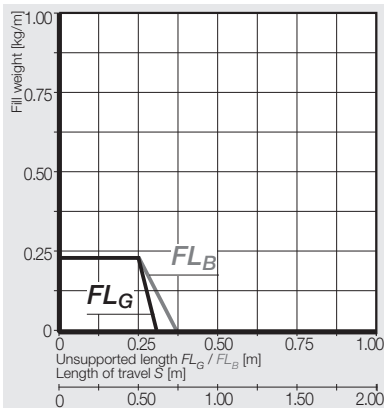

<i>R</i>	010	012	015	018	028
<i>H</i>	28	32	38	44	64
<i>D</i>	29	31	34	37	47
<i>K</i>	55	60	70	80	110

The required clearance height:  $H_F = H + 10$  mm (with 0,1 kg/m fill weight)



Mounting brackets, polymer one-piece | pivoting

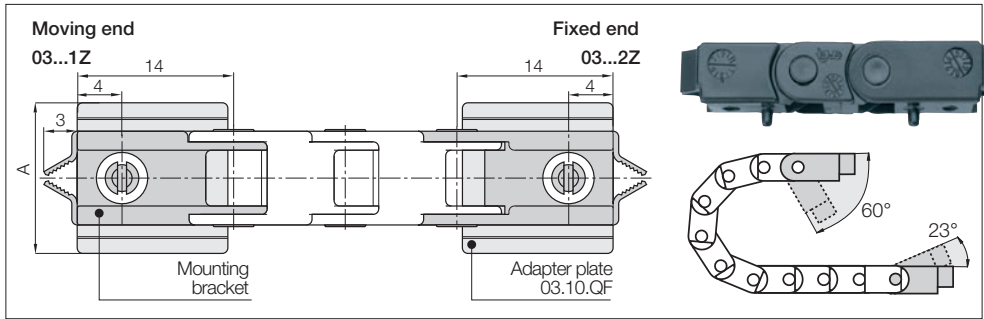

Width Index	Part No. full set	Dim A [mm]
.05. ▶	03.05. 12Z	8,7
.07. ▶	03.07. 12Z	10,7
.10. ▶	03.10. 12Z	13,7

Material mounting bracket - igumid G, temperature: -40° up to +120° C, VDE 0304 IIC UL94-HB

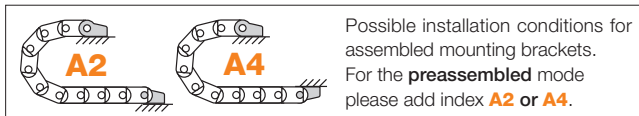

Possible installation conditions for assembled mounting brackets. For the **preassembled** mode please add index **A2** or **A4**.

Part No. structure

03.05. 12Z **A2**

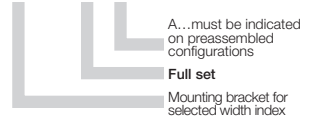

Additional Features

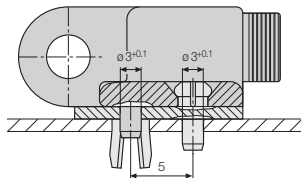

Adapter plate for rapid installation: for all sizes of Part No. 03.10.QF

The adapter has broken edges so that it can be adapted to the respective chain width. It is not absolutely necessary when attaching the mounting brackets. The mounting brackets can also be screwed on without the adapter plate.



## Series E04 | Split crossbar along the outer radius

Split crossbar along outer radius	<i>Bi</i> [mm]	<i>Ba</i> [mm]	<i>R</i> Bending radii [mm]	Weight [kg/m]
E04.07.R.0 <sup>1)</sup>	7	13	015   018   028   038   048	≈ 0,08

1) Crossbars do not overlap. Gap = 2,5 mm

Special solution with opening gap 0,8 mm: Part No. E04.07.015.0.S

Supplement Part No. with required radius (*R*) Example: E04.07.028.0

*Ba*: pin dimension approx. 0,1 - 0,3 mm wider.

## Dimensions

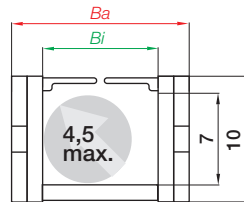
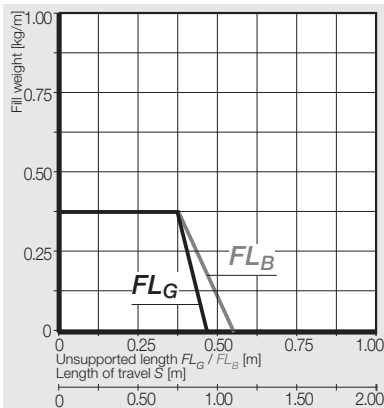

Inner height 7 mm  
 Pitch 16,7 mm/link  
 Links/m 60 (1002 mm)  
 Chain length  $S/2 + K$

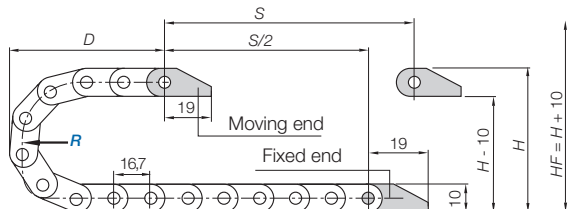

<i>R</i>	015	018	028	038	048
<i>H</i>	40	46	66	86	106
<i>D</i>	45	48	58	68	78
<i>K</i>	85	90	125	155	185

The required clearance height:  $H_F = H + 10$  mm (with 0,1 kg/m fill weight)

Mounting brackets, polymer one-piece | pivoting | More features ► [www.igus.eu/eu/E04](http://www.igus.eu/eu/E04)

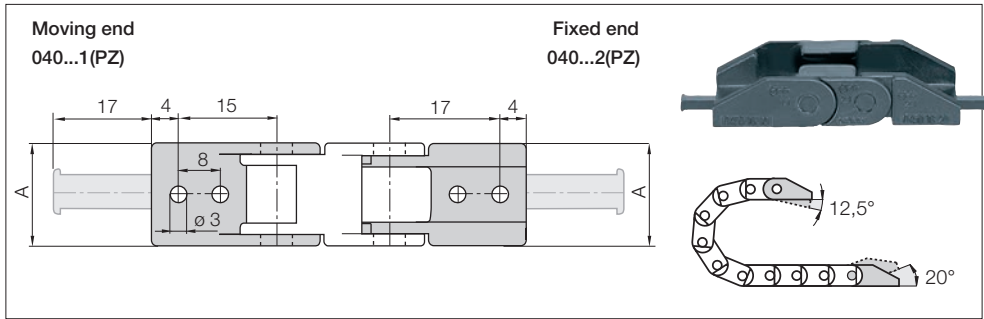

Width Index	Part No. full set with tie-wrap plates	Part No. full set without tie-wrap plates	Dim A [mm]	Number of teeth
.07. ►	040.07.12PZ	040.07.12	12	1

Material mounting bracket - igumid G, temperature: -40° up to +120° C, VDE 0304 IIC UL94-HB

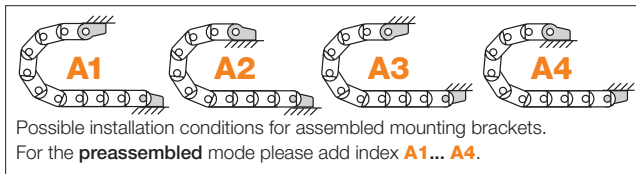

Part No. structure

**040.07. 12 PZ A2** A... must be indicated on preassembled configurations  
 With strain relief tie-wrap plates  
**Full set**  
 Mounting bracket for selected width index

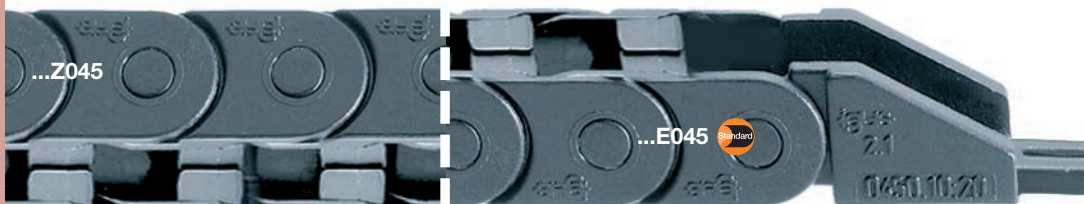

## Series E045 | Split crossbar along the outer radius | 1 / 2 / 3-chamber system

## Series Z045 | Split crossbar along the inner radius | 1 / 2-chamber system

Chamber system	Split crossbar along outer radius	Split crossbar along inner radius	$B_i$ [mm]	$B_a$ [mm]	$R$ Bending radii [mm]	Weight [kg/m]
<b>1-chamber</b> 	E045.10.R.0 <sup>1)</sup>	Z045.10.R.0 <sup>1)</sup> *	10	16	018   028   038	≈ 0,09
	E045.16.R.0	Z045.16.R.0	16	23	018   028   038	≈ 0,11
1) Crossbars do not overlap. Gap = 2 mm <span style="float: right;">*Width available upon request, please consult igus® for delivery time</span>						
<b>2-chamber</b> 	E045.2/7.R.0 <sup>2)</sup>	Z045.2/7.R.0 <sup>2)</sup>	7 / 7	23	018   028   038	≈ 0,13
	E045.2/9.R.0 <sup>2)</sup>	Z045.2/9.R.0 <sup>2)</sup> *	9 / 9	27	018   028   038	≈ 0,14
2) Crossbars do not overlap. Gap = 2,25 mm <span style="float: right;">*Width available upon request, please consult igus® for delivery time</span>						
<b>3-chamber</b> 	E045.3/9.R.0 <sup>3)</sup>	Z045.3/9.R.0 <sup>3)</sup> *	9 / 9 / 9	37	018   028   038	≈ 0,17
3) Crossbars do not overlap. Gap = 2,25 mm <span style="float: right;">*Width available upon request, please consult igus® for delivery time</span>						

Supplement Part No. with required radius ( $R$ ) Example: **E045.16.038.0**

$B_a$ : pin dimension approx. 0,1 - 0,3 mm wider.

## Dimensions

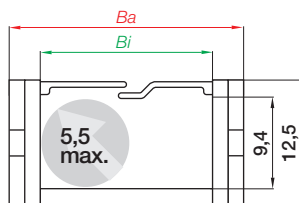
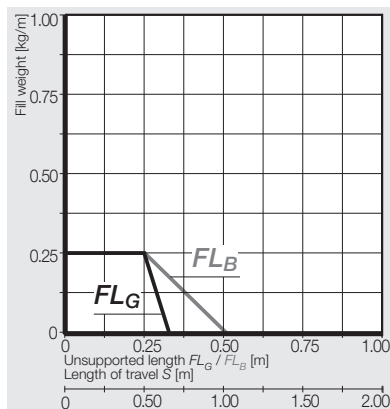

Inner height 9,4 mm  
 Pitch 13 mm/link  
 Links/m 77 (1001 mm)  
 Chain length  $S/2 + K$

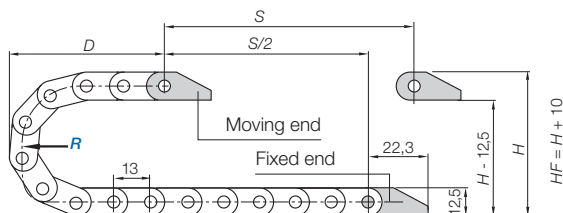

$R$	018	028	038
$H$	48,5	68,5	88,5
$D$	44	54	64
$K$	85	115	150

The required clearance height:  $H_f = H + 10$  mm (with 0,1 kg/m fill weight)

Mounting brackets, polymer one-piece | one side pivoting

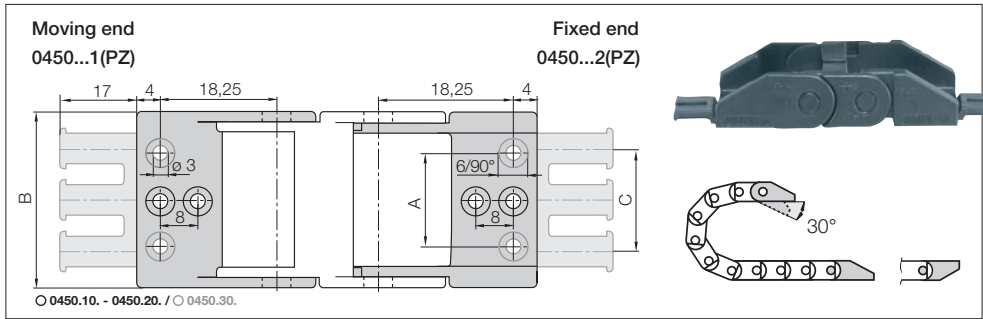

Width Index	Part No. full set with tiewrap plates	Part No. full set without tiewrap plates	Dim A [mm]	Dim B [mm]	Dim C [mm]	Number of teeth
.10. ▶	0450.10.12PZ	0450.10.12	–	16	–	1
.16. ▶	0450.16.12PZ	0450.16.12	–	22	10	2
.2/7. ▶	0450.16.12PZ	0450.16.12	–	22	10	2
.2/9. ▶	0450.20.12PZ	0450.20.12	–	26	10	2
.3/7. ▶	0450.30.12PZ	0450.30.12	22	36	20	3

Material mounting bracket - igumid G, temperature: -40° up to +120° C, VDE 0304 IIC UL94-HB

Mounting bracket with strain relief tiewrap plate has reductions of  $\varnothing 3$  mm /  $\varnothing 6$  mm, 90°.

Mounting bracket without strain relief tiewrap plate only has holes of  $\varnothing 3$  mm.

○ Drilling pattern for width index: 0450.10 - 0450.20. center bores only / ○ 0450.30. outer bores only (see figure above)

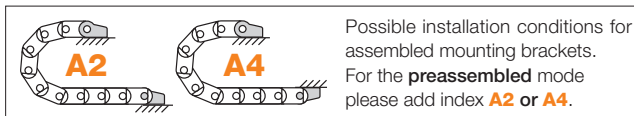

Part No. structure

0450.10.12 PZ **A2** A... must be indicated on preassembled configurations

- With strain relief tiewrap plates
- Full set
- Mounting bracket for selected width index



Series E06 | Split crossbar along the outer radius

Series Z06 | Split crossbar along the inner radius

 Split crossbar along outer radius	Split crossbar along inner radius	<i>Bi</i> [mm]	<i>Ba</i> [mm]	<i>R</i> Bending radii [mm]			Weight [kg/m]
E06.10 .R.0 <sup>1)</sup>	Z06.10 .R.0 <sup>1)</sup>	10	16,5	018	028	038	≈ 0,14
E06.16 .R.0 <sup>1)</sup>	Z06.16 .R.0 <sup>1)</sup>	16	22,5	018	028	038	≈ 0,16
E06.20 .R.0	Z06.20 .R.0	20	26,5	018	028	038	≈ 0,18

1) Crossbars do not overlap. Gap = 5,5 mm

Special solution with opening gap 3,5 mm: Part No. E06.10.018.0.S3

Supplement Part No. with required radius (*R*) Example: E06.10.028.0

*Ba*: pin dimension approx. 0,2 - 0,4 mm wider.

## Dimensions

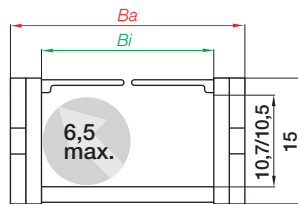
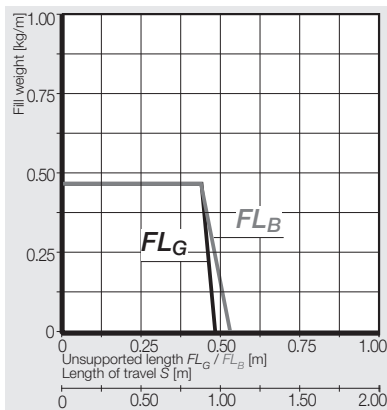

Inner height

Version E 10,7

Version Z 10,5 mm

Pitch 20 mm/link

Links/m 50 (1000 mm)

Chain length  $\frac{S}{2} + K$

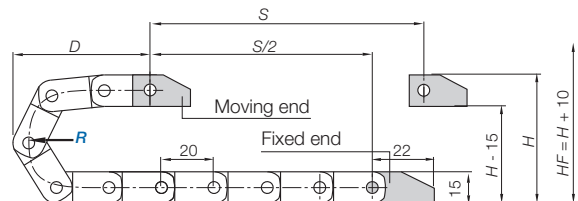

<i>R</i>	018	028	038
<i>H</i>	51	71	91
<i>D</i>	56	66	76
<i>K</i>	100	130	160

The required clearance height:  $H_F = H + 10$  mm (with 0,2 kg/m fill weight)

Mounting brackets, polymer one-piece | locking | More features ► [www.igus.eu/eu/E06](http://www.igus.eu/eu/E06)

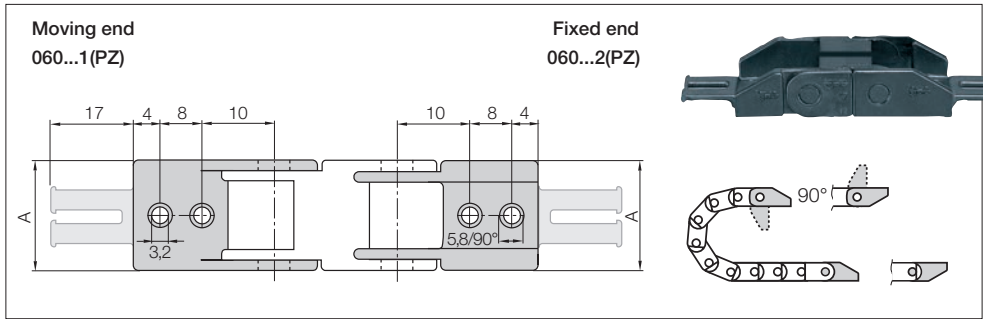

Width Index	 Part No. full set <b>with</b> tiewrap plates	Part No. full set <b>without</b> tiewrap plates	Dim A [mm]	Number of teeth
.10. ►	<b>060.10.12PZ</b>	<b>060.10.12</b>	16,5	1
.16. ►	<b>060.16.12PZ</b>	<b>060.16.12</b>	22,5	2
.20. ►	<b>060.20.12PZ</b>	<b>060.20.12</b>	27,0	2

Material mounting bracket - igumid G, temperature: -40° up to +120° C, VDE 0304 IIC UL94-HB

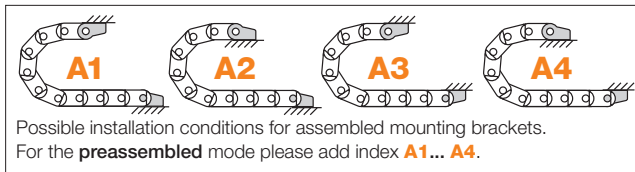

**Part No. structure**

**060.10. 12 PZ A1** A...must be indicated on preassembled configurations  
 With strain relief tiewrap plates  
**Full set**  
 Mounting bracket for selected width index

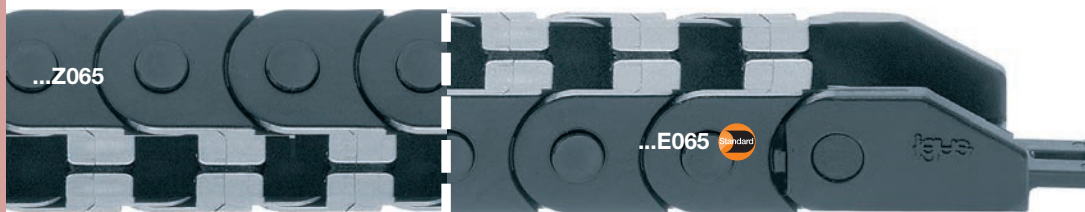

Series E065 | Split crossbar along the outer radius | 1 / 2 / 3 / 4-chamber system

Series Z065 | Split crossbar along the inner radius | 3-chamber system

Chamber system	Split crossbar along outer radius	Split crossbar along inner radius	Bi [mm]	Ba [mm]	R Bending radii [mm]	Weight [kg/m]
1-chamber	E065.16.R.0 <sup>1)</sup>	Z065.16.R.0 <sup>1)</sup> *	16	24,8	018   028   038	≈ 0,17
2-chamber	E065.2/9.R.0 <sup>2)</sup>	Z065.2/9.R.0 <sup>2)</sup> *	9 / 9	29,3	018   028   038	≈ 0,19
3-chamber	E065.3/9.R.0 <sup>3)</sup>	Z065.3/9.R.0 <sup>3)</sup> *	9 / 9 / 9	39,3	018   028   038	≈ 0,22
4-chamber	E065.4/9.R.0 <sup>4)</sup>	Z065.4/9.R.0 <sup>4)</sup> *	9 / 9 / 9 / 9	49,3	018   028   038	≈ 0,25

1) Crossbars do not overlap. Gap = 2,5 mm \*Width available upon request, please consult igus® for delivery time

2) Crossbars do not overlap. Gap = 2,5 mm \*Width available upon request, please consult igus® for delivery time

3) Crossbars do not overlap. Gap = 2,5 mm \*Width available upon request, please consult igus® for delivery time

4) Crossbars do not overlap. Gap = 2,5 mm \*Width available upon request, please consult igus® for delivery time

Supplement Part No. with required radius (R) Example: E065.16.038.0

Ba: pin dimension approx. 0,2 - 0,4 mm wider.

Dimensions

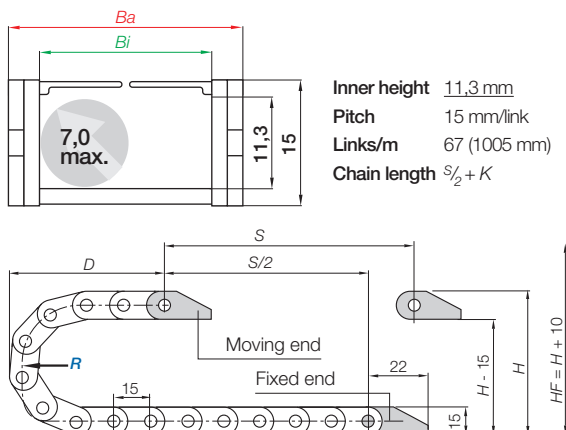
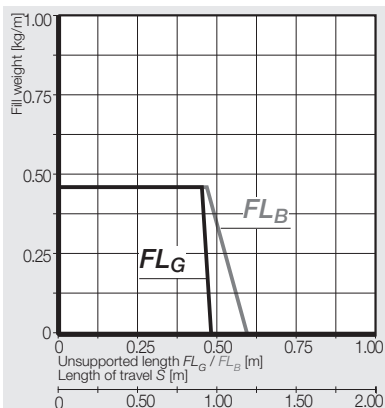

R	018	028	038
H	51	71	91
D	48	58	68
K	90	120	150

The required clearance height:  $H_F = H + 10$  mm (with 0,2 kg/m fill weight)



Mounting brackets, polymer one-piece | locking | More features ► [www.igus.eu/eu/E065](http://www.igus.eu/eu/E065)

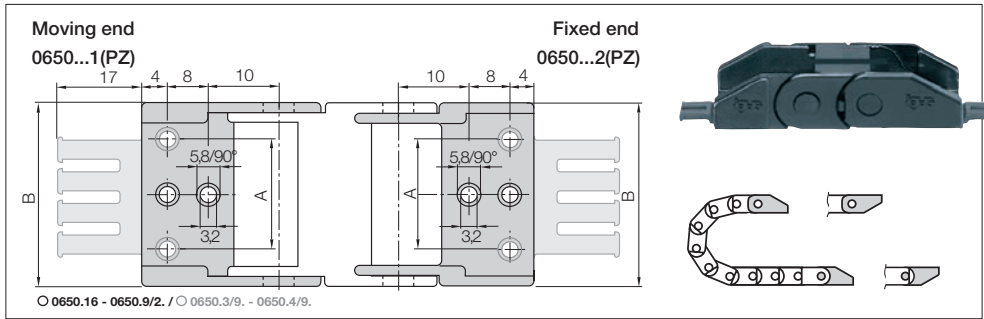

Width Index	Part No. full set with tiewrap plates	Part No. full set without tiewrap plates	Dim A [mm]	Dim B [mm]	Number of teeth
.16. ►	0650.16.12PZ	0650.16.12	–	22,5	2
.2/9. ►	0650.2/9.12PZ	0650.2/9.12	–	27	2
.3/9. ►	0650.3/9.12PZ	0650.3/9.12	22	37	3
.4/9. ►	0650.4/9.12PZ	0650.4/9.12	32	47	4

Material mounting bracket - igumid G, temperature: -40° up to +120° C, VDE 0304 IIC UL94-HB

○ Drilling pattern for width index: 0650.16 - 0650.9/2. center bores only / ○ 0650.3/9. - 0650.4/9 outer bores only (see figure above)

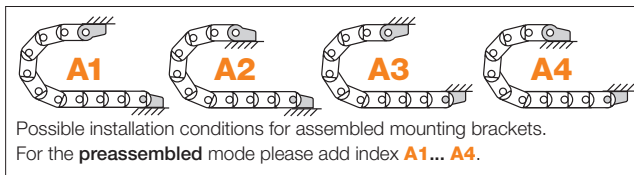

Part No. structure

0650.16. 12 PZ **A2** A...must be indicated on preassembled configurations

- With strain relief tiewrap plates
- Full set**
- Mounting bracket for selected width index



Series E08 | Split crossbar along the outer radius  
 Series Z08 | Split crossbar along the inner radius

 Split crossbar along outer radius	Split crossbar along inner radius	<i>Bi</i> [mm]	<i>Ba</i> [mm]	<i>R</i> Bending radii [mm]	Weight [kg/m]
E08.10 .R.0 <sup>1)</sup>	Z08.10 .R.0 <sup>1)</sup>	10	18,2	025*   028   038   048	≈ 0,21
E08.16 .R.0 <sup>2)</sup>	Z08.16 .R.0 <sup>2)</sup>	16	24,2	025*   028   038   048	≈ 0,24
E08.20 .R.0	Z08.20 .R.0	20	28,2	025*   028   038   048	≈ 0,25
E08.30 .R.0	Z08.30 .R.0	30	38,2	025*   028   038   048	≈ 0,28
E08.40 .R.0	Z08.40 .R.0	40	48,2	025*   028   038   048	≈ 0,31
E08.50 .R.0	Z08.50 .R.0	50	58,2	025*   028   038   048	≈ 0,37

<sup>1)</sup> Crossbars do not overlap. Gap = 5,5 mm / <sup>2)</sup> Crossbars do not overlap. Gap = 4,0 mm

\*Radius available upon request, please consult igus® for delivery time

Supplement Part No. with required radius (*R*) Example: E08.10.028.0

*Ba*: pin dimension approx. 0,3 - 0,5 mm wider.

## Dimensions

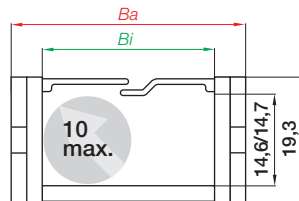
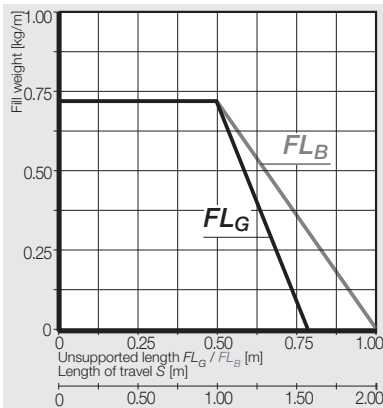

### Inner height

Version E 14,6

Version Z 14,7 mm

Pitch 20 mm/link

Links/m 50 (1000 mm)

Chain length  $\frac{S}{2} + K$

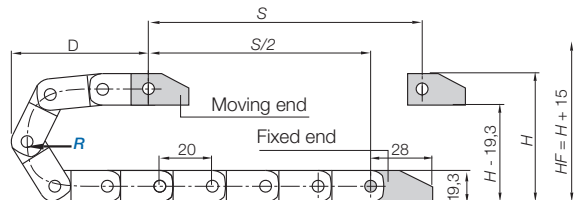



<i>R</i>	025*	028	038	048
<i>H</i>	69	75	95	115
<i>D</i>	65	68	78	88
<i>K</i>	120	130	160	195

The required clearance height:  $H_c = H + 15$  mm (with 0,3 kg/m fill weight)

\*Radius available upon request, please consult igus® for delivery time

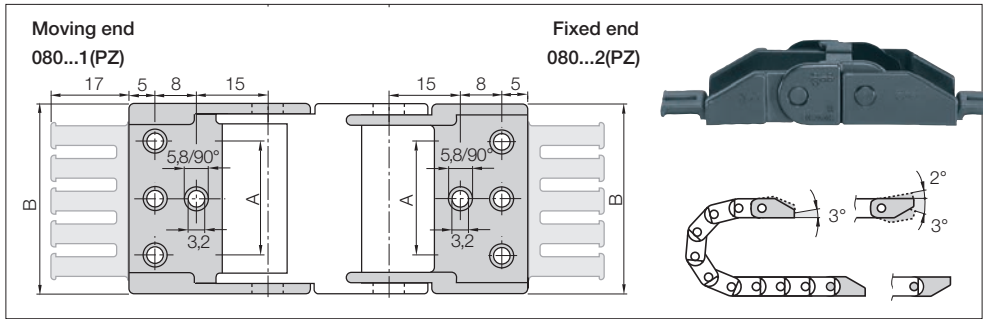
Mounting brackets, polymer one-piece | locking | More features ► [www.igus.eu/eu/08](http://www.igus.eu/eu/08)



Width Index	 Part No. full set <b>with</b> tiewrap plates	Part No. full set <b>without</b> tiewrap plates	Dim A [mm]	Dim B [mm]	Number of teeth
.10. ►	<b>080.10. 12PZ</b>	<b>080.10. 12</b>	–	18,2	1
.16. ►	<b>080.16. 12PZ</b>	<b>080.16. 12</b>	–	24,2	2
.20. ►	<b>080.20. 12PZ</b>	<b>080.20. 12</b>	–	28,2	2
.30. ►	<b>080.30. 12PZ</b>	<b>080.30. 12</b>	22	38,2	3
.40. ►	<b>080.40. 12PZ</b>	<b>080.40. 12</b>	32	48,2	4
.50. ►	<b>080.50. 12PZ</b>	<b>080.50. 12</b>	42	58,2	5

Material mounting bracket - igumid G, temperature: -40° up to +120° C, VDE 0304 IIC UL94-HB

Drilling pattern for width index: **080.10. - 080.20.** center bores only / **080.30. - 080.50.** all bores (see figure above)

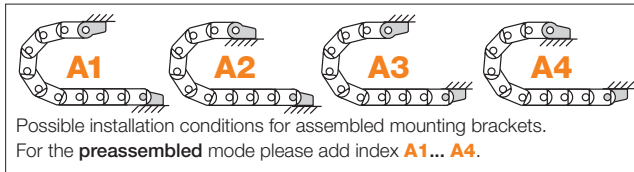

**Part No. structure**

**080.10. 12 PZ A2** A... must be indicated on preassembled configurations  
 With strain relief tiewrap plates  
**Full set**  
 Mounting bracket for selected width index

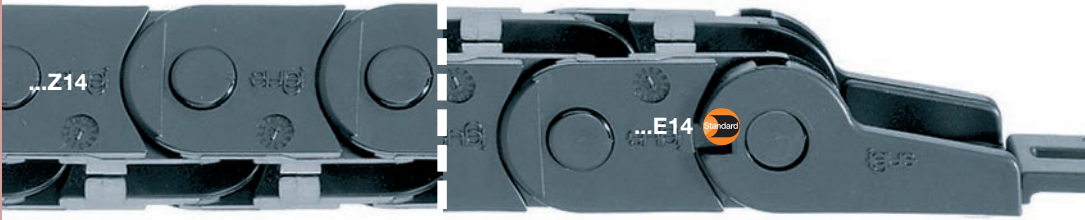

**Series E14 | Split crossbar along the outer radius**  
**Series Z14 | Split crossbar along the inner radius**

 Split crossbar along outer radius	Split crossbar along inner radius	<i>Bi</i> [mm]	<i>Ba</i> [mm]	<i>R</i> Bending radii [mm]	Weight [kg/m]
E14. 1 .R.0	Z14. 1 .R.0	15	27	028   038   048   075   100   125	≈ 0,31
E14. 2 .R.0	Z14. 2 .R.0	25	37	028   038   048   075   100   125	≈ 0,32
E14. 3 .R.0	Z14. 3 .R.0	38	50	028   038   048   075   100   125	≈ 0,40
E14. 4 .R.0	Z14. 4 .R.0	50	62	028   038   048   075   100   125	≈ 0,44

Supplement Part No. with required radius (*R*) Example: **E14.1.028.0**

*Ba*: pin dimension approx. 0,3 - 0,5 mm wider.

## Dimensions

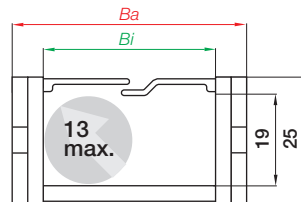
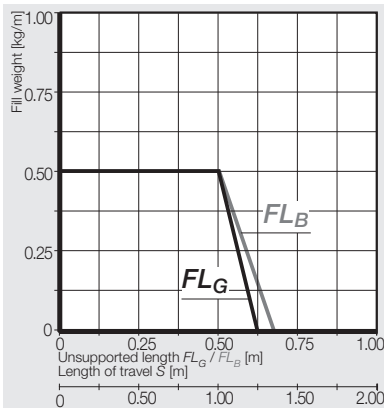

Inner height 20 mm  
 Pitch 30,5 mm/link  
 Links/m 33 (1006,5 mm)  
 Chain length  $S/2 + K$

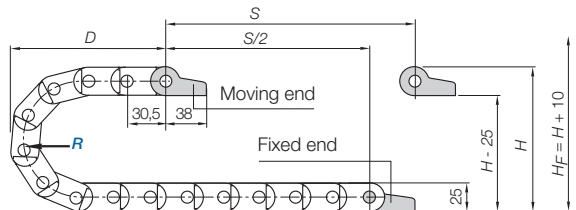

<i>R</i>	028	038	048	075	100	125
<i>H</i>	81	101	121	175	225	275
<i>D</i>	86	96	106	133	158	183
<i>K</i>	150	185	215	300	380	455

The required clearance height:  $H_F = H + 10$  mm (with 0,2 kg/m fill weight)

Mounting brackets, polymer one-piece | locking | More features ► [www.igus.eu/eu/E14](http://www.igus.eu/eu/E14)

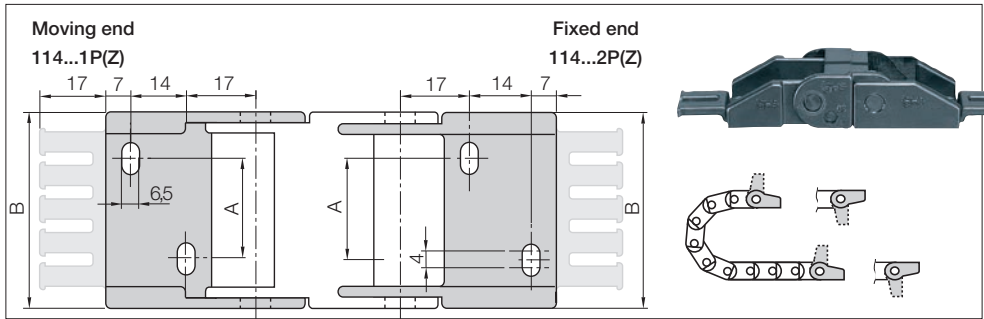

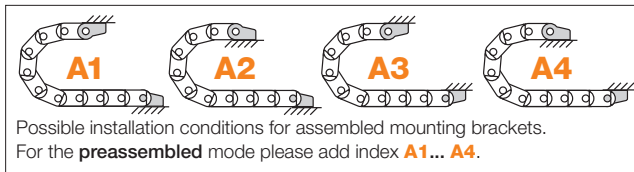

Width Index	 Part No. full set with tie-wrap plates	Part No. full set without tie-wrap plates	Dim A [mm]	Dim B [mm]	Number of teeth
1. ►	<b>114.1.12PZ</b>	<b>114.1.12P</b>	–	26,3	2
2. ►	<b>114.2.12PZ</b>	<b>114.2.12P</b>	10	36,3	3
3. ►	<b>114.3.12PZ</b>	<b>114.3.12P</b>	23	49,3	4
4. ►	<b>114.4.12PZ</b>	<b>114.4.12P</b>	35	61,3	5

Material mounting bracket - igumid G, temperature: -40° up to +120° C, VDE 0304 IIC UL94-HB



Part No. structure

<b>114.2. 12 PZ A1</b>	A...must be indicated on preassembled configurations
	With strain relief tie-wrap plates
	Full set
	Mounting bracket for selected width index

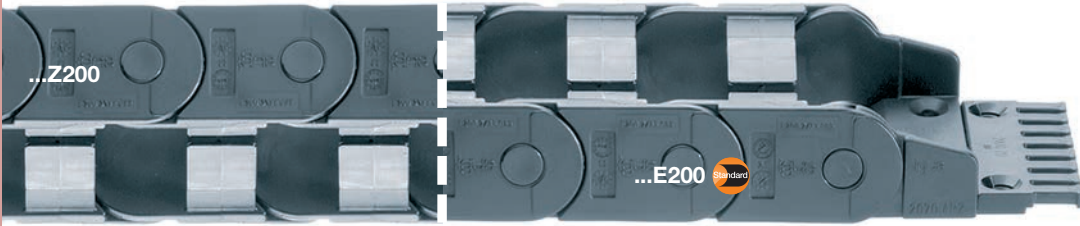

Series E200 | Split crossbar along the outer radius | 1 / 2-chamber system  
Series Z200 | Split crossbar along the inner radius | 1 / 2-chamber system

Chamber system	Split crossbar along outer radius	Split crossbar along inner radius	Bi [mm]	Ba [mm]	R Bending radii [mm]					Weight [kg/m]
1-chamber	E200.05.R.0	Z200.05.R.0	57	74,4	055	075	100	150	200	≈ 0,70
2-chamber	E200.2/35.R.0	Z200.2/35.R.0	37/37	94,4	055	075	100	150	200	≈ 0,79
	E200.2/50.R.0	Z200.2/50.R.0	50/50	120,4	055	075	100	150	200	≈ 0,82



Supplement Part No. with required radius (R) Example: E200.05.150.0

Ba: pin dimension approx. 0,1 - 0,3 mm wider.

Dimensions

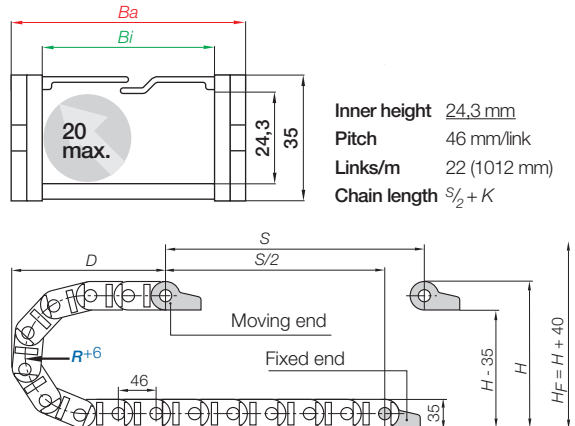
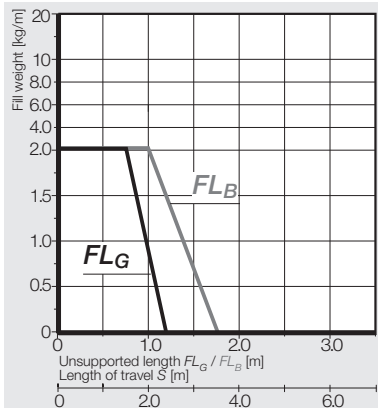

R	055	075	100	150	200
H +4	145	185	235	335	435
D	142	162	187	237	287
K	265	330	410	565	725

The required clearance height:  $H_F = H + 40$  mm (with 2,0 kg/m fill weight)

Mounting brackets, polymer | pivoting | locking

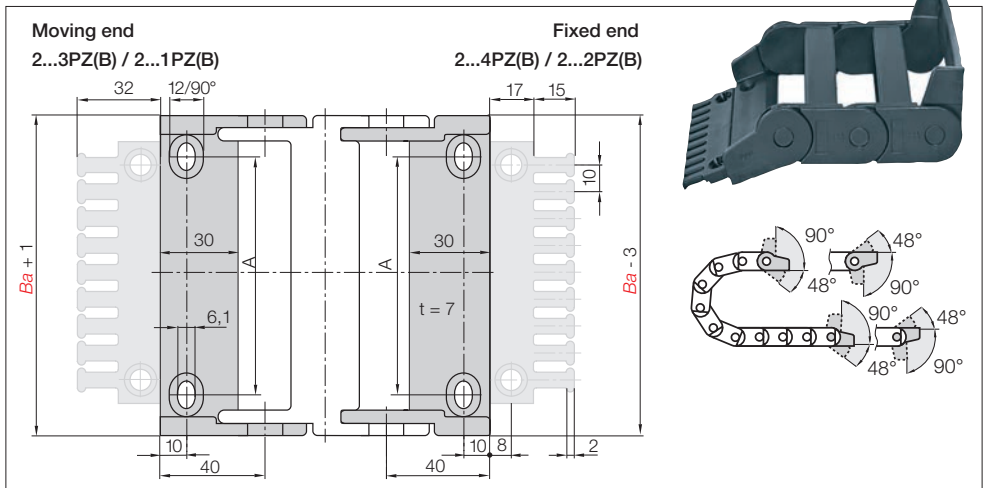

Width Index	Standard	Part No. full set pivoting:		Part No. full set locking:		Dim A [mm]	Number of teeth
		with tiewrap plates	without tiewrap plates	with tiewrap plates	without tiewrap plates		
.05.	▶	2050.34PZB	2050.34PZ	2050.12PZB	2050.12PZ	44	6
.2/35.	▶	2070.34PZB	2070.34PZ	2070.12PZB	2070.12PZ	64	8
.2/50.	▶	2100.34PZB	2100.34PZ	2100.12PZB	2100.12PZ	90	10

Material mounting bracket - igumid G, temperature: -40° up to +120° C, VDE 0304 IIC UL94-HB

Full set with tiewrap plate + 10 cable tiewraps, please add index **K1** ▶ e.g. 2050.34PZBK1

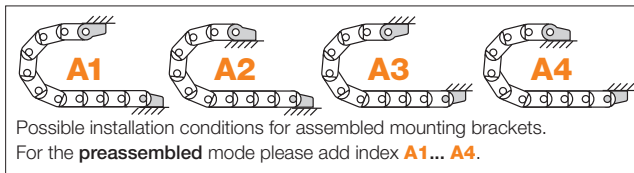

Part No. structure

**2050. 34 PZB A1** A...must be indicated on preassembled configurations  
 With strain relief tiewrap plates  
**Full set pivoting**  
 Mounting bracket for selected width index

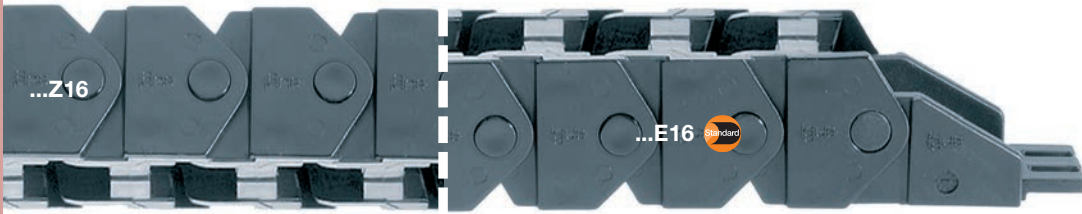
Series E16 | Split crossbar along the outer radiusSeries Z16 | Split crossbar along the inner radius

Split crossbar along outer radius	Split crossbar along inner radius	<i>Bi</i> [mm]	<i>Ba</i> [mm]	<i>R</i> Bending radii [mm]	Weight [kg/m]
E16. 2 .R.0 <sup>1)</sup>	Z16. 2 .R.0	23	37,5	040 <sup>1)</sup>  060 075 100 125*	≈ 0,51
E16. 3 .R.0	Z16. 3 .R.0 <sup>1)</sup>	36	50,5	040 <sup>1)</sup>  060 075 100 125*	≈ 0,57
E16. 4 .R.0	Z16. 4 .R.0 <sup>1)</sup>	48	62,5	040 <sup>1)</sup>  060 075 100 125*	≈ 0,62
E16. 5 .R.0	Z16. 5 .R.0	63	78,5	040* 060 075 100 125*	≈ 0,75
E16. 6 .R.0	Z16. 6 .R.0	80	95,5	040* 060 075 100 125*	≈ 0,83
E16. 7 .R.0	Z16. 7 .R.0	100	115,3	040* 060 075 100 125*	≈ 0,91

<sup>1)</sup>Radius available upon request, please consult igus\* for delivery time 1) Radius 040 only for E16.2. / Z16.3. / Z16.4 available)

Special solution with opening gap 3 mm: Part No. E16.2.100.0.N3 / Z16.2.075.0.N3

Supplement Part No. with required radius (*R*) Example: E16.7.100.0

*Ba*: pin dimension approx. 0,3 - 0,7 mm wider.

## Dimensions

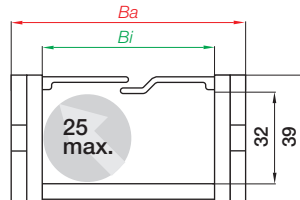
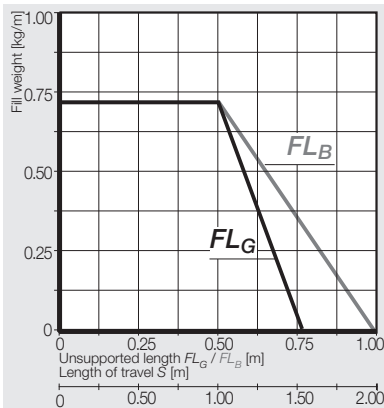

Inner height 32 mm  
Pitch 30,5 mm/link  
Links/m 33 (1006,5 mm)  
Chain length  $S/2 + K$

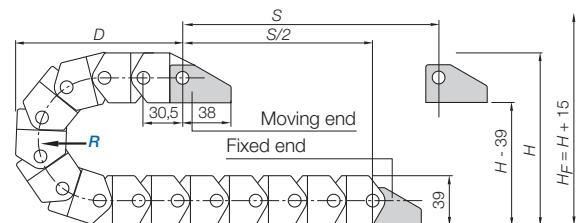

<i>R</i>	040*	060	075	100	125*
<i>H</i>	119	159	189	239	289
<i>D</i>	105	125	140	165	190
<i>K</i>	190	250	300	380	455

The required clearance height:  $H_c = H + 15$  mm (with 0,3 kg/m fill weight)

\*Radius available upon request, please consult igus\* for delivery time (Radius 040 for Z16.03 / Z16.04 available)



Mounting brackets, polymer one-piece | locking | More features ► [www.igus.eu/eu/E16](http://www.igus.eu/eu/E16)

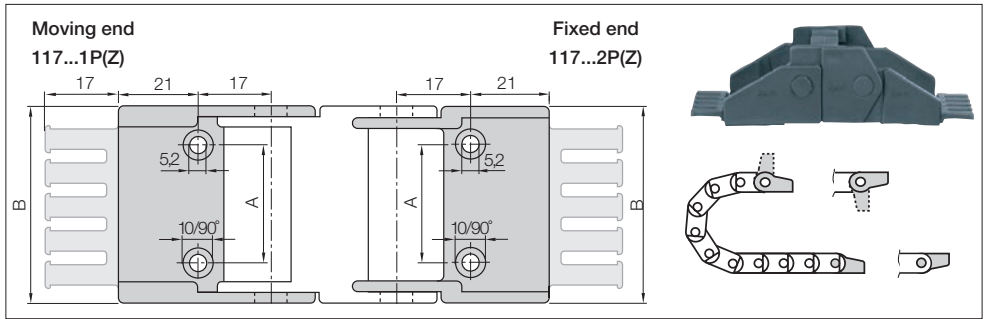

Width Index	 Part No. full set with tie-wrap plates	Part No. full set without tie-wrap plates	Dim A [mm]	Dim B [mm]	Number of teeth
.2. ►	117.2.12PZ	117.2.12P	12	35,5	3
.3. ►	117.3.12PZ	117.3.12P	25	48,5	4
.4. ►	117.4.12PZ	117.4.12P	37	60,5	5
.5. ►	117.5.12PZ	117.5.12P	48	76,0	6
.6. ►	117.6.12PZ	117.6.12P	65	93,0	8
.7. ►	117.7.12PZ	117.7.12P	85	113,0	10

Material mounting bracket - igumid G, temperature: -40° up to +120° C, VDE 0304 IIC UL94-HB

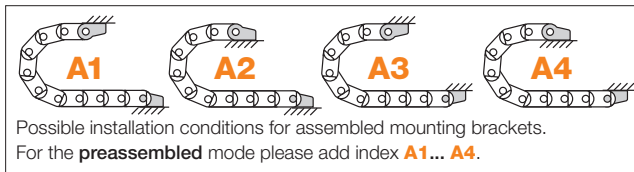

Part No. structure

117.2. 12 PZ **A1**

- A...must be indicated on preassembled configurations
- With strain relief tie-wrap plates
- Full set locking**
- Mounting bracket for selected width index

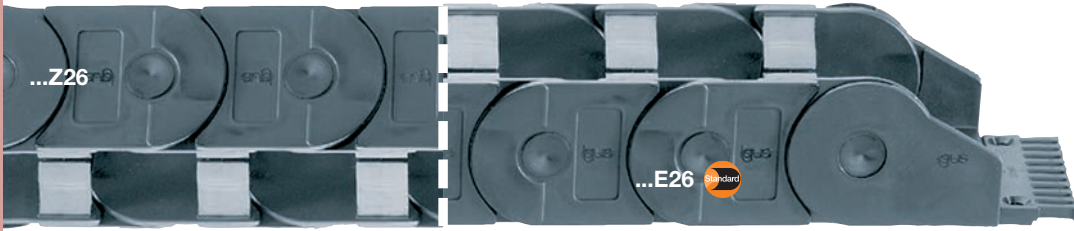

Series E26 | Split crossbar along the outer radius | 1 / 2 / 3-chamber system

Series Z26 | Split crossbar along the inner radius | 1 / 2 / 3-chamber system

Chamber system	Split crossbar along outer radius	Split crossbar along inner radius	Bi [mm]	Ba [mm]	R Bending radii [mm]	Weight [kg/m]
1-chamber	E26.07.R.0	Z26.07.R.0	75	92	063   075   100   125   150   175   200   250	≈ 0,96
2-chamber	E26.2/45.R.0	Z26.2/45.R.0	48/48	117	063   075   100   125   150   175   200   250	≈ 1,14
3-chamber	E26.3/45.R.0	Z26.3/45.R.0	47/48/47	167	063   075   100   125   150   175   200   250	≈ 1,30

Supplement Part No. with required radius (R) Example: E26.07.150.0

Ba: pin dimension approx. 0,3 - 0,5 mm wider.

## Dimensions

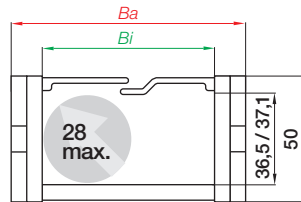
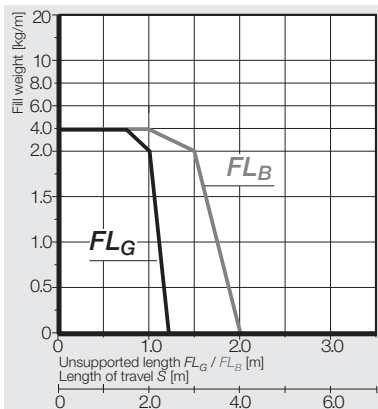

Inner height

1-chamber 36,5 mm

2/3-chamber 37,1 mm

Pitch 56 mm/link

Links/m 18 (1008 mm)

Chain length  $\frac{S}{2} + K$

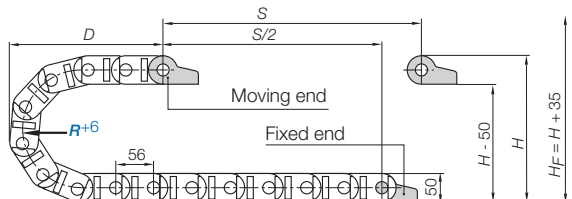

R	063	075	100	125	150	175	200	250
H +5	176	200	250	300	350	400	450	550
D	172	184	209	234	259	284	309	359
K	310	350	430	505	585	665	745	900

The required clearance height:  $H_F = H + 35$  mm (with 2,0 kg/m fill weight)

Mounting brackets, polymer | pivoting | locking

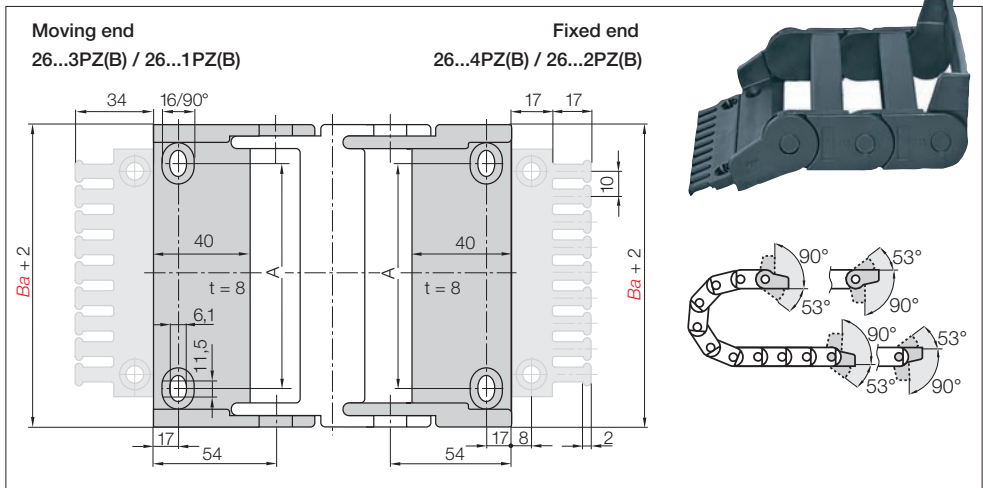

Width Index	Standard	Part No. full set pivoting:		Part No. full set locking:		Dim A [mm]	Number of teeth
		with tiewrap plates	without tiewrap plates	with tiewrap plates	without tiewrap plates		
07.	▶	2607.34PZB	2607.34PZ	2607.12PZB	2607.12PZ	55	7
2/45.	▶	2610.34PZB	2610.34PZ	2610.12PZB	2610.12PZ	80	10
3/45.	▶	2615.34PZB	2615.34PZ	2615.12PZB	2615.12PZ	130	15

Material mounting bracket - igumid G, temperature: -40° up to +120° C, VDE 0304 IIC UL94-HB

Full set with tiewrap plate + 10 cable tiewraps, please add index **K1** ▶ e.g. 2607.34PZBK1

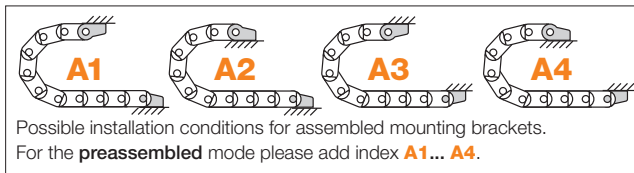

Part No. structure

**2607. 34 PZB A2** A...must be indicated on preassembled configurations  
With strain relief tiewrap plates  
**Full set pivoting**  
Mounting bracket for selected width index

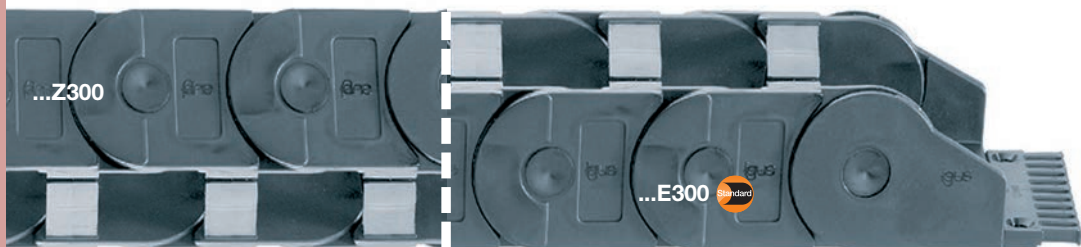

Series E300 | Split crossbar along the outer radius | 1 / 2 / 3-chamber system  
Series Z300 | Split crossbar along the inner radius | 1 / 2 / 3-chamber system

Chamber system	Split crossbar along outer radius	Split crossbar along inner radius	Bi [mm]	Ba [mm]	R Bending radii [mm]	Weight [kg/m]
1-chamber	E300.075.R.0	Z300.075.R.0	75	95	075   100   125   150   200   250   300	≈ 1,60
2-chamber	E300.2/45.R.0	Z300.2/45.R.0	48/48	120	075   100   125   150   200   250   300	≈ 1,78
3-chamber	E300.3/45.R.0	Z300.3/45.R.0	47/46/47	170	075   100   125   150   200   250   300	≈ 1,92

Supplement Part No. with required radius (R) Example: E300.075.150.0

Ba: pin dimension approx. 0,3 - 0,5 mm wider.

## Dimensions

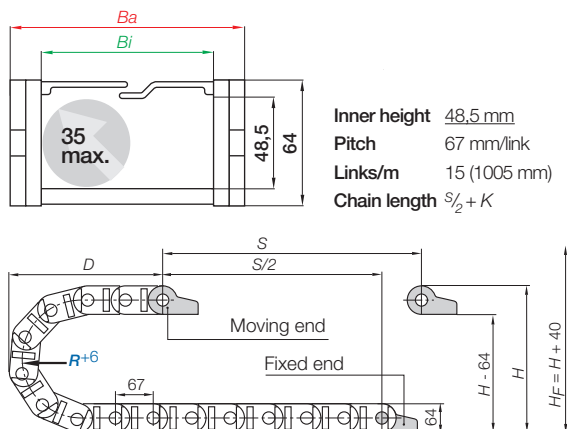
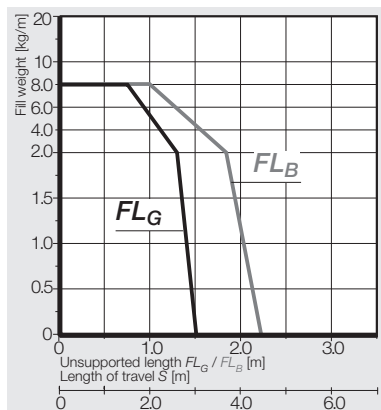

Inner height 48,5 mm  
Pitch 67 mm/link  
Links/m 15 (1005 mm)  
Chain length  $\frac{S}{2} + K$

R	075	100	125	150	200	250	300
H +5	214	264	314	364	464	564	664
D	208	233	258	283	333	383	433
K	370	450	530	610	765	920	1080

The required clearance height:  $H_F = H + 40$  mm (with 2,5 kg/m fill weight)

Mounting brackets, polymer | pivoting | locking

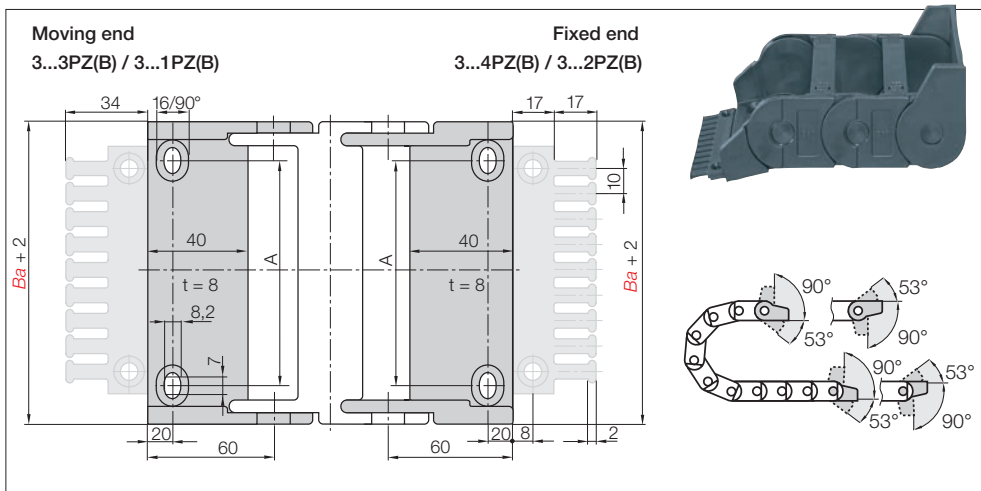

Width Index	Part No. full set pivoting:		Part No. full set locking:		Dim A [mm]	Number of teeth
	with tiewrap plates	without tiewrap plates	with tiewrap plates	without tiewrap plates		
.075. ▶	3075.34PZB	3075.34PZ	3075.12PZB	3075.12PZ	53	7
.2/45. ▶	3100.34PZB	3100.34PZ	3100.12PZB	3100.12PZ	78	10
.3/45. ▶	3150.34PZB	3150.34PZ	3150.12PZB	3150.12PZ	128	15

Material mounting bracket - igumid G, temperature: -40° up to +120° C, VDE 0304 IIC UL94-HB

Full set with tiewrap plate + 10 cable tiewraps, please add index **K1** ▶ e.g. 3075.34PZBK1

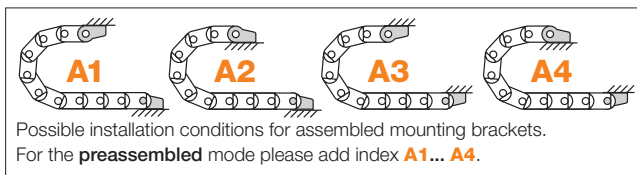

Part No. structure

**2607. 34 PZB A2** A... must be indicated on preassembled configurations  
With strain relief tiewrap plates  
**Full set pivoting**  
Mounting bracket for selected width index

Interior separation



Optional shelving for E300.3/45 and Z300.3/45 -Full-width shelf 386.54

Shelving enables subdivision of the inner space of the e-chain® Series E300.3/45 and Z300.3/45. This option makes sense in applications with many thin cables with similar diameters. For a consequent subdivision. Full-width shelves can be arranged at 7 different heights (in 7 mm increments). In standard configurations, shelves are installed in every other link.

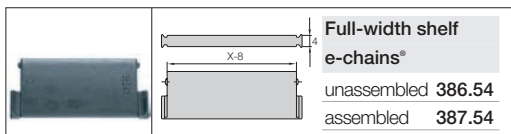

Easy to lengthen:  
Strips can simply be  
snapped together

Easy to shorten:  
Separation at each band

Save time:  
Very easy to fill because  
of snap-open lids

Cost effective:  
Low-price e-chain®

Space-efficient:  
Compact design with  
smooth outer contour

Variations:  
Different materials and  
colors available upon request

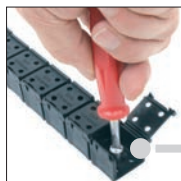

Easy  
attachment to  
the machine



E1 - e-chain® on one strip - easy to lengthen and to shorten...

## E1 - Modular, one-piece strip design for simple applications

E1: e-chain® modular, 1-piece strip designed for simple applications - The E1 design brings the benefits of an e-chain® to applications, where this solution previously was too expensive. E1 is more economic for higher volumes, quicker to assemble and still offers great control and protection for moving cables. The igus®-System E1 is very cost effective for high volumes and is especially ideal for automotive applications.

### Typical industries and applications

- Automotive
- Office solutions and technology
- Automation
- Electric equipment
- Machine-building



UL94-V2  
classification



# E1 | Selection Table | Technical Data | Order key

Series	Inner height <i>hi</i> [mm]	Inner width <i>Bi</i> [mm]	Outer width <i>Ba</i> [mm]	Outer height <i>ha</i> [mm]	Bending radius <i>R</i> [mm]	Segment length [mm]	Page
--------	--------------------------------	-------------------------------	-------------------------------	--------------------------------	---------------------------------	------------------------	------



**E1 one-piece strip -**  
snap-open along outer radius

E1.10.013.	10	13	16,5	15,5	18	200	166
E1.17.021.	17	21	26	25	28	255	167
E1.17.031.	17	31	36	25	28	204	167
E1.17.044.	17	44	49	25	28	255	167
E1.18.015.	18	15	20	26	28	127,5	168
E1.20.015.	20	15	22	27	28	250	169

## Technical Data



Material - permitted temperature °C, igumid NB

-40° up to +80° C



Flammability class igumid NB

VDE 0304 IIC UL94-V2

## Order example | Order key and color options based on Series E1.17



Order example for complete e-chain® (1,0 m), color black

e-chain® (1,0 m)

Please indicate chain-lengths or number of links

**E1.17.044.028.0**

Order text: 1,0 m E1.17.044.028.0



Order key

E1 snap-open along outer radius® **E1.17.044.028.0**

Series / Type

Width index (depends on *Bi*)

Bending radius *R*

Color index (standard black)



E1.17.044.028.0 = Snap-open along outer radius, inner width *Bi* 44 mm, radius *R* 28 mm, color black

## General igus® color options for e-chains® and e-tubes

Color	Order index	Color	Order index
Black Standard, from stock!	.0	White special color	.1
Slate grey only ESD material	.ESD	Gray white special color	.1S
Gray brown only HT material	.HT	Orange special color	.2
Gray special color only e-chains®	.3	Yellow special color	.4
Dusty grey special color only e-tubes	.31	Light grey special color	.14

Black e-chains® available from stock!

Delivery time for special colors: upon request



## Series E1.10 | Snap-open along outer radius

Snap-open along outer radius	<i>Bi</i> [mm]	<i>Ba</i> [mm]	<i>R</i> Bending radii [mm]	Weight [kg/Segment]
<b>E1.10.013.R.0</b>	<b>13</b>	<b>16,5</b>	<b>018</b>	≈ 0,0164

Supplement Part No. with required radius (*R*) Example: **E1.10.13.018.0**

## Dimensions

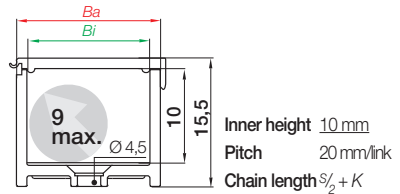
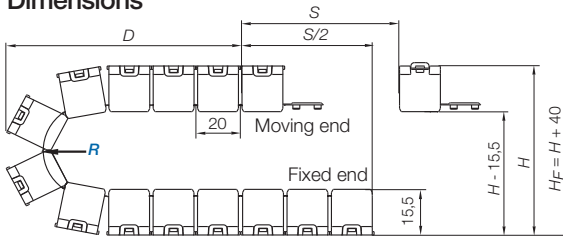

Series	Segment length Dim A [mm]	No. of links/Segment	No. of Segments/m
<b>E1.10.013.R.0</b>	200	10	5 (1000 mm)

<i>R</i>	<b>018</b>
<i>H</i>	62
<i>D</i>	66
<i>K</i>	100

The required clearance height:  $H_F = H + 40$  mm

More radii available upon request,  
please consult igus® for delivery time!

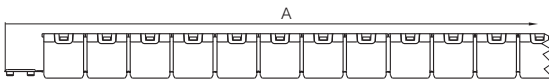





### Series E1.17 | Snap-open along outer radius

Snap-open along outer radius	<i>Bi</i> [mm]	<i>Ba</i> [mm]	<i>R</i> Bending radii [mm]	Weight [kg/Segment]
E1.17.021.R.0	21	26	028	≈ 0,0478
E1.17.031.R.0	31	36	028	≈ 0,0460
E1.17.044.R.0	44	49	028	≈ 0,0695

Supplement Part No. with required radius (*R*) Example: E1.17.021.028.0

### Dimensions

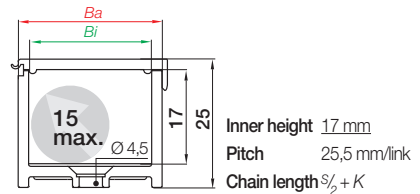
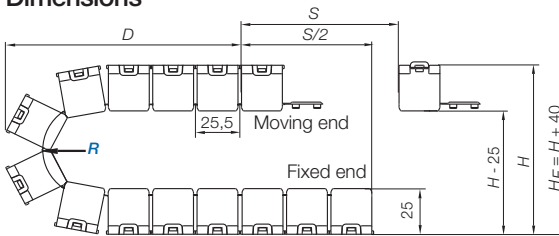

Series	Segment length Dim A [mm]	No. of links/Segment	No. of Segments/m
E1.17.021.R.0	255	10	4 (1020 mm)
E1.17.031.R.0	204	8	5 (1020 mm)
E1.17.044.R.0	255	10	4 (1020 mm)

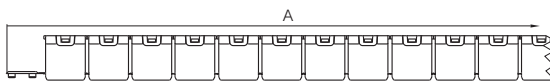

<i>R</i>	028
<i>H</i>	92
<i>D</i>	76
<i>K</i>	120

The required clearance height:  $H_F = H + 40$  mm

More radii available upon request, please consult igus® for delivery time!

### Mounting brackets for the Series E1.17.021 | New in this catalog



Compact, universal mounting bracket for E1.17.021: Part No. E1.170.021.TS - easy attachment



## Series E1.18 | Snap-open along outer radius

Snap-open along outer radius	<i>Bi</i> [mm]	<i>Ba</i> [mm]	<i>R</i> Bending radii [mm]	Weight [kg/Segment]
<b>E1.18.015.R.0</b>	<b>15</b>	<b>20</b>	<b>028</b>	~0,0169

Supplement Part No. with required radius (*R*) Example: **E1.18.15.028.0**

## Dimensions

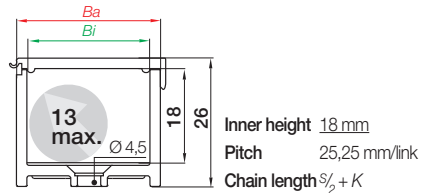
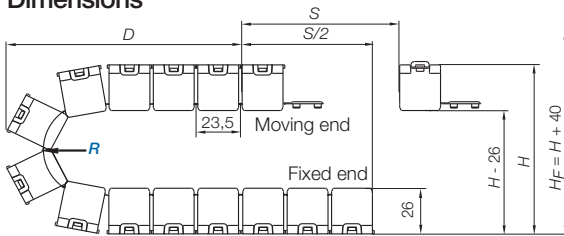

Series	Segment length Dim A [mm]	No. of links/Segment	No. of Segments/m
<b>E1.18.015.R.0</b>	101	4	10 (1010 mm)

<i>R</i>	<b>028</b>
<i>H</i>	92
<i>D</i>	76
<i>K</i>	120

The required clearance height:  $H_F = H + 40$  mm

More radii available upon request,  
please consult igus® for delivery time!

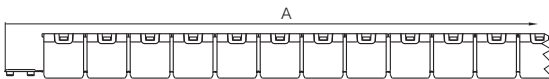

# E1 | Series E1.20 | Delivery program

e-chain® on one strip - small size, lids open reciprocally



## Series E1.20 | Snap-open along outer radius - lids open reciprocally

Snap-open along outer radius	<i>Bi</i> [mm]	<i>Ba</i> [mm]	<i>R</i> Bending radii [mm]	Weight [kg/Segment]
E1.20.015.R.0	15	22	028	≈ 0,0443

Supplement Part No. with required radius (*R*) Example: E1.20.15.028.0

### Dimensions

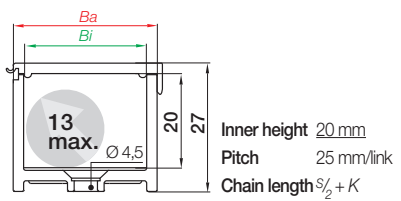
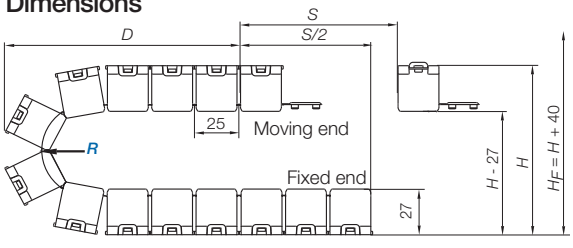

Series	Segment length Dim A [mm]	No. of links/Segment	No. of Segments/m
E1.20.015.R.0	250	10	4 (1000 mm)

<i>R</i>	028
<i>H</i>	92
<i>D</i>	76
<i>K</i>	120

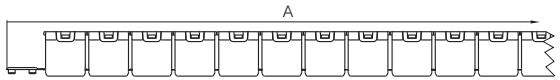

The required clearance height:  $H_F = H + 40$  mm

More radii available upon request, please consult igus® for delivery time!

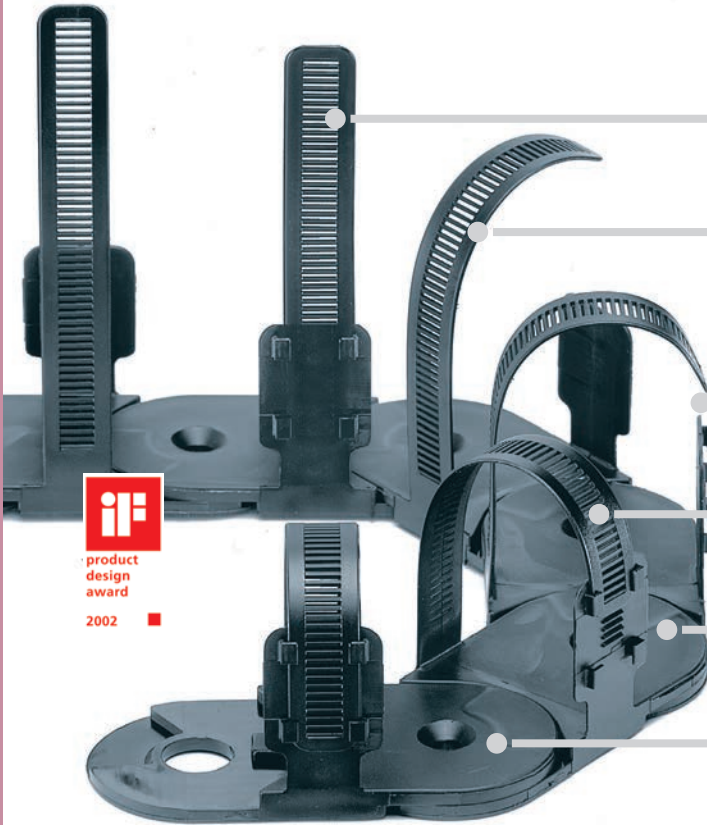

Save time:  
Fit cable assemblies quickly in bunches, available in 2 sizes

Flexible:  
Adjust and change loops at any time

Opening principle:  
Version TE14/TE26 can be opened along the outer and TZ14/TZ26 can be opened along the inner radius

Simple:  
Favorable alternative to complex hinged cable trays

Short lengths:  
Well-suited to short lengths, ideally 5 - 10 links

Flexible:  
Can be bent in 1 or 2 directions

## snapchain - fit cable assemblies quickly in bunches

igus® snapchain economical e-chains® for simple fillings. snapchains are easy to assemble and cost-effective. If an easy solution for minor number of travels is required.

### Typical industries and applications

- Switch cubicle construction
- Electrical equipment
- Computer cubicles
- Office furniture
- Wherever cables are moved infrequently

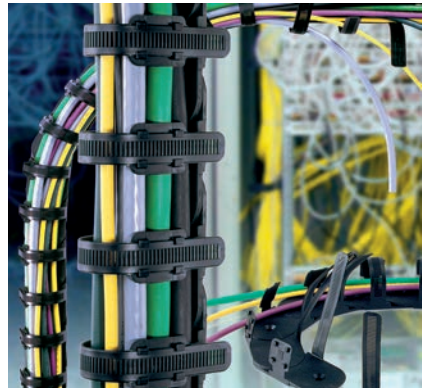

Series	Length loops [mm]	Pitch [mm]	Bending radius <i>R</i> [mm]	Page
				
<b>Version TE -</b> Loops to be opened along the outer radius				
<b>Version TZ -</b> Loops to be opened along the inner radius				
TE14.50	50	30,5	028 - 125	172
TE26.120	120	56	063 - 200	173
TZ14.50	50	30,5	028 - 125	172
TZ26.120	120	56	063 - 200	173

## Technical Data

	Material - permitted temperature °C, igumid NB	-40° up to +80° C
	Flammability class igumid NB	VDE 0304 IIC UL94-V2

## Order example | Order key and color options based on Series TE26.

 Order example for complete e-chain® (1,0 m), color black:

e-chain® (1,0 m)	Please indicate chain-lengths or number of links	TE26.120.100.0
------------------	--	----------------

Order text: 1,0 m TE26.120.100.0

## Order key











Version TE to be opened along the outer radius  
Version TZ to be opened along the inner radius

TE26.120.100.0  
TZ26.120.100.0

Version "TE" or "TZ"  
Series / Type  
Length of loops  
Bending radius *R*  
Color index (standard black)



## General igus® color options for e-chains® and e-tubes

Color	Order index	Color	Order index
 Black Standard, from stock	.0	 White special color	.1
 Slate grey only ESD material	.ESD	 Gray white special color	.1S
 Gray brown only HT material	.HT	 Orange special color	.2
 Gray special color only e-chains®	.3	 Yellow special color	.4
 Dusty grey special color only e-tubes	.31	 Light grey special color	.14

Black e-chains® available from stock!

Delivery time for special colors: upon request

TE26.120.100 = Version "TE" - Loops to be opened along the outer radius, radius *R* 100 mm, color black

TZ26.120.100 = Version "TZ" - Loops to be opened along the inner radius, radius *R* 100 mm, color black



Series TE14 | Loops to be opened along the outer radius

Series TZ14 | Loops to be opened along the inner radius

To be opened along the outer radius	To be opened along the inner radius	<b>R</b> Bending radii [mm]	Weight [kg/m]
TE14.50. <b>R.0</b> *	TZ14.50. <b>R.0</b>	028   038   048   075   100   125	≈ 0,15

\*also available as RBR (Reverse bending radius) Part No. TE14.50.Radius/Radius

Supplement Part No. with required radius (*R*) Example: TE14.50.100.0

## Dimensions

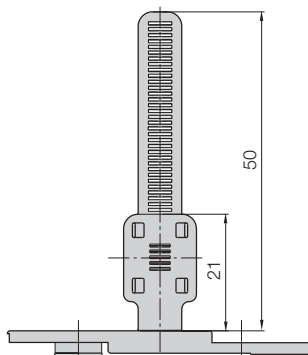
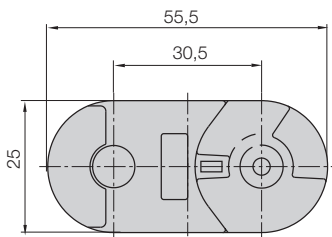

Pitch 30,5 mm/link  
Links/m 33 (1006,5 mm)  
Chain length  $\frac{S}{2} + K$

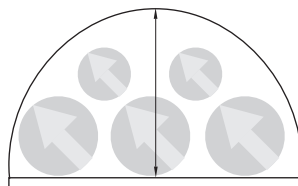

Cable package max.: 18 mm



Fit cable assemblies quickly in bunches - large size



Series TE26 | Loops to be opened along the outer radius  
 Series TZ26 | Loops to be opened along the inner radius

To be opened along the outer radius	To be opened along the inner radius	R Bending radii [mm]	Weight [kg/m]
TE26.120.R.0*	TZ26.120.R.0	063   075   100   125   150   200	≈ 0,43

\*also available as RBR (Reverse bending radius) Part No. TE26.120.Radius/Radius

Supplement Part No. with required radius (R) Example: TE26.120.100.0

### Dimensions

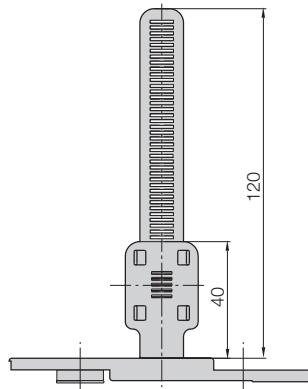
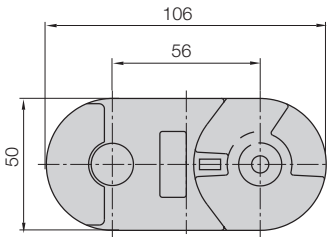

Pitch 56 mm/link  
 Links/m 18 (1008 mm)  
 Chain length  $S/2 + K$

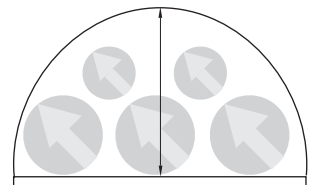

Cable package max.: 47 mm

Universal:  
Mounting bracket with  
strain relief option

Fast opening:  
zip-open along  
outer radius

Quiet:  
Small pitch for low-  
noise, smooth running

Flexible:  
Lids can be separated  
and joined at each link

Keep order:  
Interior separation possible  
(Series 09, 15/R15, 17/R17)

Dynamic:  
High accelerations 100 m/s<sup>2</sup>  
and more are possible

Stable:  
Double stop dog for long unsupported  
travels (Series 15/R15, 17/R17)

## Fast opening and closing with "zipper"

igus® "zipper" e-chains® and e-tubes convince in practicality and performance. The "zipper" function makes them a very useful product to reduce assembly time. The small pitch, the tough-elastic zipper-band, and the sturdy link work well in high-acceleration environments. The igus® "zipper" Series is one of the most popular e-chain® Series in demanding applications.

- zipper-like design for quick opening and closing of lids
- If high stability and excellent service life is required
- Small pitch for smooth running
- If fast, zipper-like accessibility to cables is required

### Typical industries and applications

- Pick & place robots
- Semi-conductor machines
- Linear motors, actuators
- Measuring equipment
- Machine tools (zipper e-tube)

Clean room Class 1 (ISO class 3)  
tested by the Dryden Engineering  
Company, California (Series 15)



58 dB(A) tested in igus® lab,  
v = 1,0 m/s unsupported, Series 09.50.028.0



UL94-V0 classification  
upon request



Electrically conductive ESD/ATEX versions  
several Series available from stock



**iF produkt design award**  
2002 igus® Series R09  
1989 igus® Series 15





# zipper | Selection Table

Series	Inner height <i>hi</i> [mm]	Inner width <i>Bi</i> [mm]	Outer width <i>Ba</i> [mm]	Outer height <i>ha</i> [mm]	Bending radius <i>R</i> [mm]	Unsupported max. length [m]	Page
--------	--------------------------------	-------------------------------	-------------------------------	--------------------------------	---------------------------------	--------------------------------	------

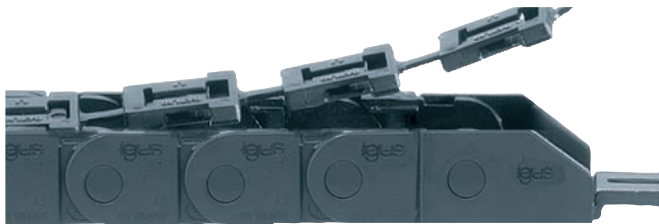

**zipper -  
two-piece e-chains®**  
zip-open along outer radius

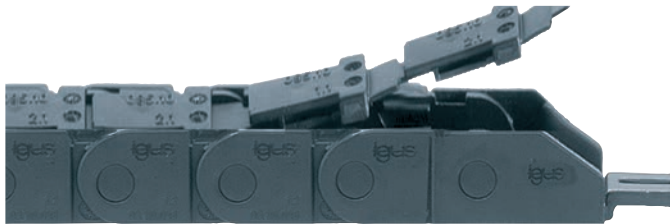

047	9,0	10 - 16	16,0 - 22,0	12,5	18 - 38	0,40	178
07	10,3	6 - 64	12,5 - 71,0	15,0	18 - 48	0,55	180
09	15,0	10 - 50	18,2 - 58,2	19,3	28 - 48	1,00	184
15	17,0	15 - 100	26,0 - 113,0	24,0	38 - 180	1,20	188
17	32,0	15 - 100	25,5 - 113,0	39,0	63 - 125	1,00	192



**zipper -  
two-piece e-tubes**  
Protection against dirt and chips,  
zip-open along outer radius



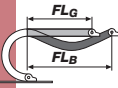

R07	10,3	10 - 50	16,5 - 57,0	15,0	38 - 48	0,55	182
R09	15,0	10 - 50	18,2 - 58,2	19,3	48 - 100	1,00	186
R15	17,0	25 - 80	36,0 - 94,0	24,0	63 - 180	1,20	190
R17	32,0	15 - 63	26,0 - 74	39,0	63 - 125	1,20	194

## Technical Data







	Gliding speed / acceleration (maximum)	max. 10 [m/s] / max. 50 [m/s <sup>2</sup> ]
	Speed / acceleration $FL_G$ max.	max. 20 [m/s] / max. 200 [m/s <sup>2</sup> ]
	Speed / acceleration $FL_B$ max.	max. 3 [m/s] / max. 6 [m/s <sup>2</sup> ]
	Material lower part - permitted temperature °C, igumid G	-40° up to +120° C
	Material lid - permitted temperature °C, igumid TE	-40° up to +70° C
	Flammability class, igumid G	VDE 0304 IIC UL94-HB

■  $FL_G$  = with straight upper run ■  $FL_B$  = with permitted sag

## Installation methods overview, maximum travels

Series e-chain® / e-tube	 Unsupported application	 Vertical hanging	 Vertical standing	 Side mounted unsupported
047	≤ 0,40 m	upon request	upon request	upon request
07	≤ 0,55 m	upon request	upon request	upon request
09	≤ 1,0 m	upon request	upon request	upon request
15	≤ 1,2 m	upon request	upon request	upon request
17	≤ 1,0 m	upon request	upon request	upon request
R07	≤ 0,55 m	upon request	upon request	upon request
R09	≤ 1,0 m	upon request	upon request	upon request
R15	≤ 1,2 m	upon request	upon request	upon request
R17	≤ 1,0 m	upon request	upon request	upon request

## Options with order keys based on Series 15

<p> <b>Standard</b></p> <p>Part No. <b>Standard</b> e-chains® / e-tubes</p> 	<p>NC-Version - (no camber) without pretension</p> <p>Part No. <b>NC-Version</b> e-chains® / e-tubes</p> <p>NC</p> 	<p>ESD / ATEX classified e-chains®</p> <p> II 2 GD</p> <p>Part No. <b>ESD-Material</b> e-chains® / e-tubes</p> 
<p> <b>15.025.R.0</b></p>	<p><b>15.025.R.0.NC</b></p>	<p><b>15.025.R.0.ESD</b></p>
<p> <b>Delivery from stock</b></p>	<p><b>Delivery time: upon request</b></p>	<p><b>Delivery time: Several series from stock</b></p>

## Order example | Order key and color options based on Series 15

 **Order example for complete e-chain® (1,0 m), color black, with mounting brackets and interior separation:**











e-chain® (1,0 m)	Please indicate e-chain® length or number of links: 1,0 m or 33 links	<b>15.025.075.0</b>
+ Mounting brackets	1 set (with integrated strain relief)	<b>1025.34PZ</b>
+ Interior separation	with 2 separators assembled every 2 <sup>nd</sup> link	<b>2 x 154</b>

Order text: 1,0 m 15.025.075.0 + 1025.34PZ + 2 x 154

### Order key

e-chain® zip-open along outer radius	<b>15.025.075.0</b>
e-tube zip-open along outer radius	<b>R15.025.075.0</b>
Series / Type	
Width index (depends on <i>Bi</i> )	
Bending radius <i>R</i>	
Color index (standard black)	

### General igus® color options for e-chains® and e-tubes

Color	Order index	Color	Order index
 <b>Black</b> Standard, from stock!	<b>.0</b>	 <b>White</b> special color	<b>.1</b>
 <b>Slate grey</b> only ESD material	<b>.ESD</b>	 <b>Gray white</b> special color	<b>.1S</b>
 <b>Gray brown</b> only HT material	<b>.HT</b>	 <b>Orange</b> special color	<b>.2</b>
 <b>Gray</b> special color only e-chains®	<b>.3</b>	 <b>Yellow</b> special color	<b>.4</b>
 <b>Dusty grey</b> special color only e-tubes	<b>.31</b>	 <b>Light grey</b> special color	<b>.14</b>

**Black e-chains® available from stock!**  
**Delivery time for special colors: upon request**

**15.025.075.0** = e-chain® zip-open along outer radius, inner width *Bi* 25 mm, radius *R* 75 mm, color black  
**R15.025.075.0** = e-tube zip-open along outer radius, inner width *Bi* 25 mm, radius *R* 75 mm, color black

**e-chain® | Series 047 | Zip-open along outer radius**

e-chain® zip-open along outer radius	<i>Bi</i> [mm]	<i>Ba</i> [mm]	<i>R</i> Bending radii [mm]	Weight [kg/m]
<b>047.10 .R.0</b>	<b>10</b>	<b>16</b>	<b>018   028   038</b>	≈ 0,10
<b>047.16 .R.0</b>	<b>16</b>	<b>22</b>	<b>018   028   038</b>	≈ 0,11

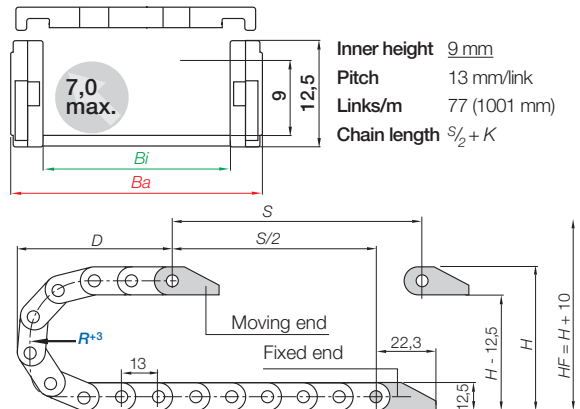
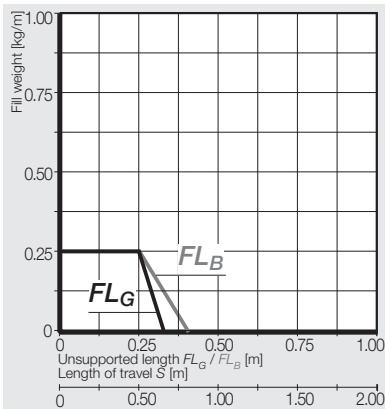
 Supplement Part No. with required radius (*R*) Example: **047.10.038.0**
**Dimensions**

<i>R</i>	<b>018</b>	<b>028</b>	<b>038</b>
<i>H</i>	48,5	68,5	88,5
<i>D</i>	44	54	64
<i>K</i>	85	115	150

 The required clearance height:  $H_F = H + 10$  mm (with 0,2 kg/m fill weight)

Mounting brackets, polymer one-piece | one side pivoting

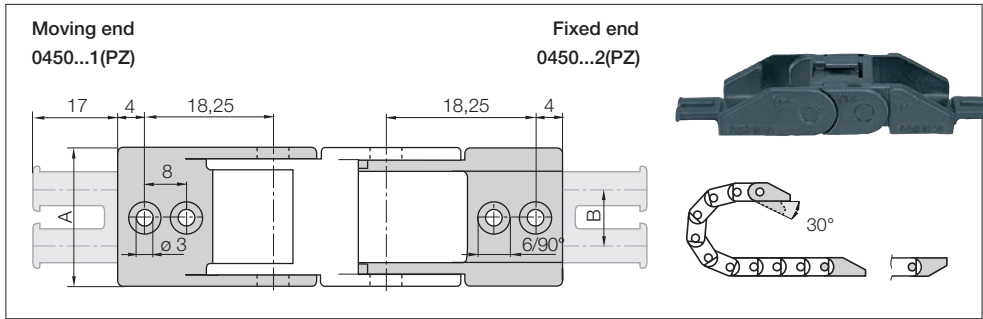

Width Index	 Part No. full set <b>with</b> tiewrap plates	Part No. full set <b>without</b> tiewrap plates	Dim A [mm]	Dim B [mm]	Number of teeth
10. ▶	<b>0450.10.12PZ</b>	<b>0450.10.12</b>	16	–	1
16. ▶	<b>0450.16.12PZ</b>	<b>0450.16.12</b>	22	10	2

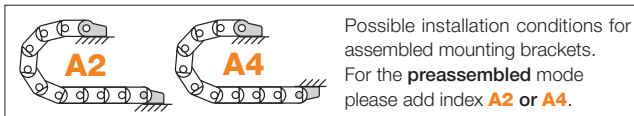

Mounting bracket with strain relief tiewrap plate has reductions of  $\varnothing 3 \text{ mm}$  /  $\varnothing 6 \text{ mm } 90^\circ$

Mounting bracket without strain relief tiewrap plate only has holes of  $\varnothing 3 \text{ mm}$



Possible installation conditions for assembled mounting brackets. For the **preassembled** mode please add index **A2** or **A4**.

Part No. structure

<b>0450.10. 12 PZ A2</b>	A...must be indicated on preassembled configurations
	With strain relief tiewrap plates
	<b>Full set</b>
	Mounting bracket for selected width index

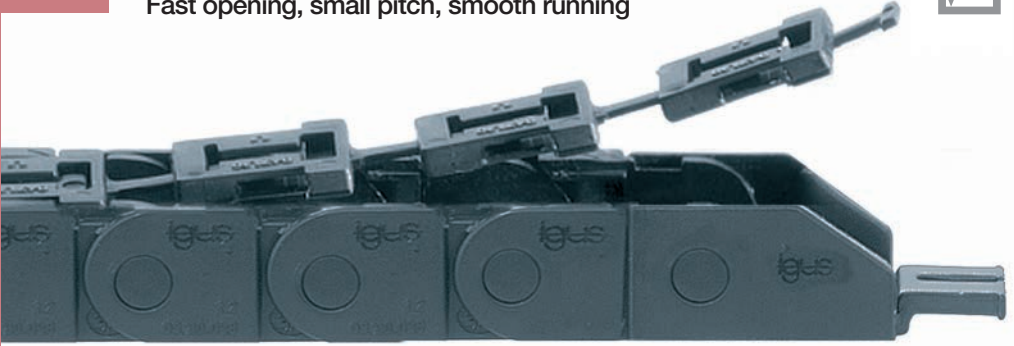

## e-chain® | Series 07 | Zip-open along outer radius

e-chain* zip-open along outer radius	<i>Bi</i> [mm]	<i>Ba</i> [mm]	<i>R</i> Bending radii [mm]	Weight [kg/m]
07. 06 .R.0	06	12,5	018  028  038  048*	≈ 0,13
07. 10 .R.0	10	16,5	018  028  038  048*	≈ 0,14
07. 16 .R.0	16	22,5	018  028  038  048*	≈ 0,16
07. 20 .R.0	20	27	018  028  038  048*	≈ 0,17
07. 30 .R.0	30	37	018  028  038  048*	≈ 0,20
07. 40 .R.0	40	47	018  028  038  048*	≈ 0,23
07. 50 .R.0	50	57	018  028  038  048*	≈ 0,26
07. 64 .R.0	64	71	018  028  038  048	≈ 0,30

Supplement Part No. with required radius (*R*) Example: 07.40.038.0

\*Radius available upon request, please consult igus® for delivery time

## Dimensions

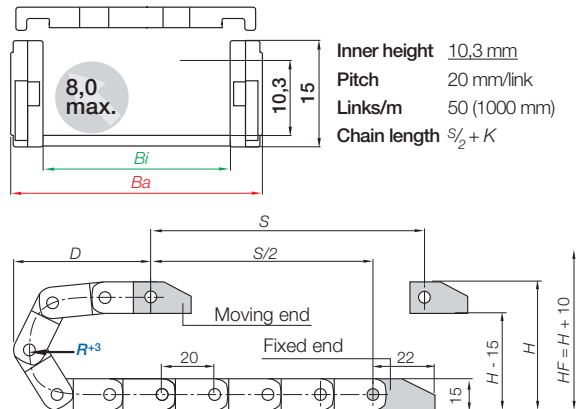
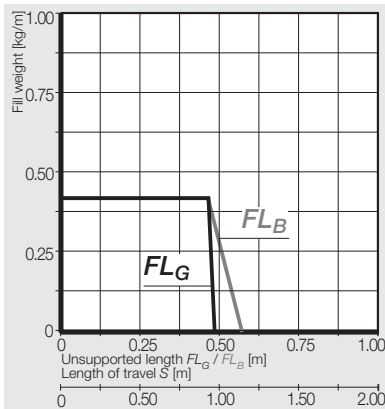

<i>R</i>	018	028	038	048*
<i>H</i>	51	71	91	111
<i>D</i>	56	66	76	86
<i>K</i>	100	130	160	195

The required clearance height:  $H_c = H + 10$  mm (with 0,2 kg/m fill weight)

\*Radius 048 only for Series 07.64 - for other widths available upon request, please consult igus® for delivery time

Mounting brackets, polymer one-piece | locking | More features ► [www.igus.eu/eu/07](http://www.igus.eu/eu/07)

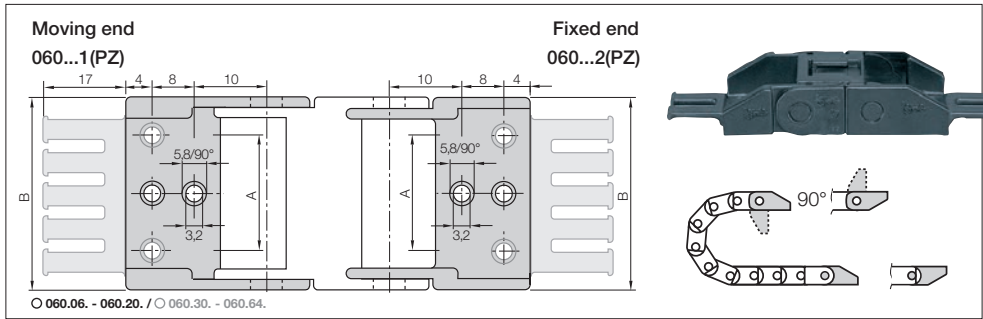

Width Index	Part No. full set with tiewrap plates	Part No. full set without tiewrap plates	Dim A [mm]	Dim B [mm]	Number of teeth
06. ►	060.06. 12PZ	060.06. 12	-	12,5	1
10. ►	060.10. 12PZ	060.10. 12	-	16,5	1
16. ►	060.16. 12PZ	060.16. 12	-	22,5	2
20. ►	060.20. 12PZ	060.20. 12	-	27,0	2
30. ►	060.30. 12PZ	060.30. 12	22	37,0	3
40. ►	060.40. 12PZ	060.40. 12	32	47,0	4
50. ►	060.50. 12PZ	060.50. 12	42	57,0	5
64. ►	060.64. 12PZ	060.64. 12	56	71,0	6

○ Drilling pattern for width index: 060.06. - 060.20. center bores only / ○ 060.30. - 060.64. outer bores only (see figure above)

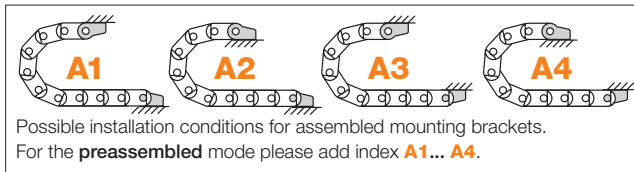

Part No. structure

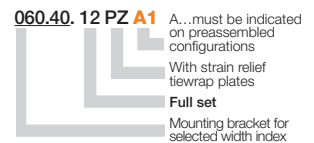

ESD/ATEX permanently conductive e-chains® - Several widths with delivery from stock:  
Inner widths **Bi 10 - 50**, radii **R 18 - 38**. Full ESD delivery program ► [www.igus.eu/eu/ESD](http://www.igus.eu/eu/ESD)



## e-tube | Series R07 | Zip-open along outer radius

e-tube zip-open along outer radius	<i>Bi</i> [mm]	<i>Ba</i> [mm]	<i>R</i> Bending radii [mm]	Weight [kg/m]
R07. 06 . <i>R</i> .0*	06	12,5	038   048	≈ 0,15
R07. 10 . <i>R</i> .0	10	16,5	038   048	≈ 0,16
R07. 16 . <i>R</i> .0	16	22,5	038   048	≈ 0,18
R07. 20 . <i>R</i> .0	20	27	038   048	≈ 0,19
R07. 30 . <i>R</i> .0	30	37	038   048	≈ 0,22
R07. 40 . <i>R</i> .0	40	47	038   048	≈ 0,25
R07. 50 . <i>R</i> .0	50	57	038   048	≈ 0,28
R07. 64 . <i>R</i> .0*	64	71	038   048	≈ 0,32

Supplement Part No. with required radius (*R*) Example: **R07.40.038.0**

\*Width available upon request, please consult igus® for delivery time

## Dimensions

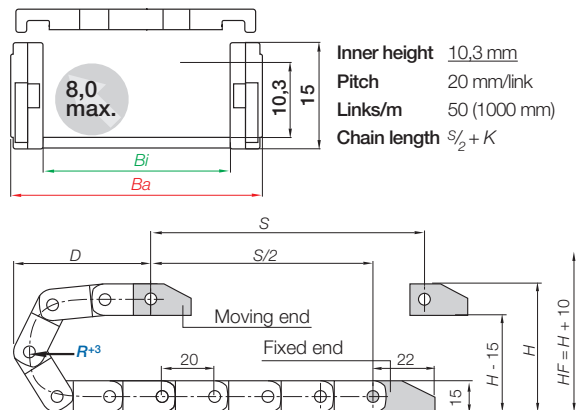
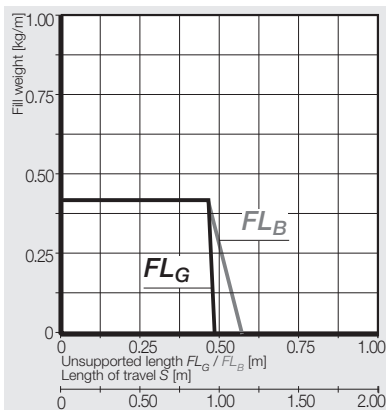



<i>R</i>	038	048
<i>H</i>	91	111
<i>D</i>	76	86
<i>K</i>	160	195

The required clearance height:  $H_F = H + 10$  mm (with 0,2 kg/m fill weight)

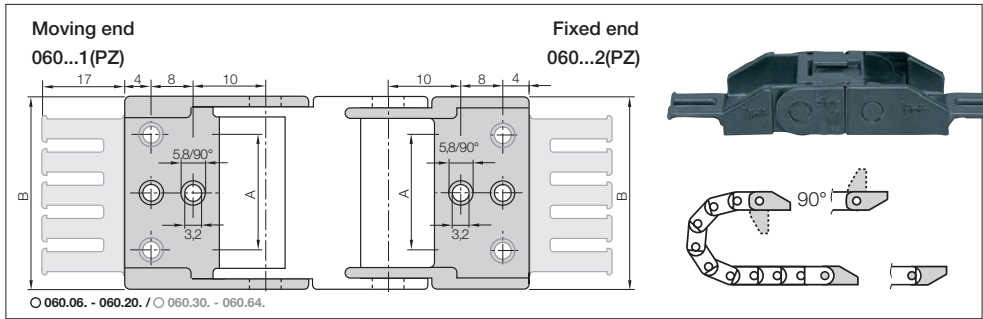

Mounting brackets, polymer one-piece | locking | More features ► [www.igus.eu/eu/R07](http://www.igus.eu/eu/R07)



Width Index	 Part No. full set with tiewrap plates	Part No. full set without tiewrap plates	Dim A [mm]	Dim B [mm]	Number of teeth
06.* ►	060.06. 12PZ	060.06. 12	–	12,5	1
10. ►	060.10. 12PZ	060.10. 12	–	16,5	1
16. ►	060.16. 12PZ	060.16. 12	–	22,5	2
20. ►	060.20. 12PZ	060.20. 12	–	27,0	2
30. ►	060.30. 12PZ	060.30. 12	22	37,0	3
40. ►	060.40. 12PZ	060.40. 12	32	47,0	4
50. ►	060.50. 12PZ	060.50. 12	42	57,0	5
64.* ►	060.64. 12PZ	060.64. 12	56	71,0	6

○ Drilling pattern for width index: 060.06. - 060.20. center bores only / ○ 060.30. - 060.64. outer bores only (see figure above)

\*Width available upon request, please consult igus\* for delivery time

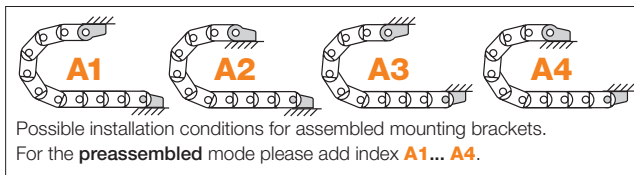

Part No. structure

**060.40. 12PZ A1** A... must be indicated on preassembled configurations  
 With strain relief tiewrap plates  
**Full set**  
 Mounting bracket for selected width index



## e-chain® | Series 09 | Zip-open along outer radius

e-chain® zip-open along outer radius	<i>Bi</i> [mm]	<i>Ba</i> [mm]	<i>R</i> Bending radii [mm]	Weight [kg/m]
09. 10 . <i>R</i> .0	10	18,2	028   038   048	≈ 0,21
09. 16 . <i>R</i> .0	16	24,2	028   038   048	≈ 0,24
09. 20 . <i>R</i> .0	20	28,2	028   038   048	≈ 0,25
09. 30 . <i>R</i> .0	30	38,2	028   038   048	≈ 0,28
09. 40 . <i>R</i> .0	40	48,2	028   038   048	≈ 0,31
09. 50 . <i>R</i> .0	50	58,2	028   038   048	≈ 0,34

Supplyment Part No. with required radius (*R*) Example: 09.40.048.0

## Dimensions

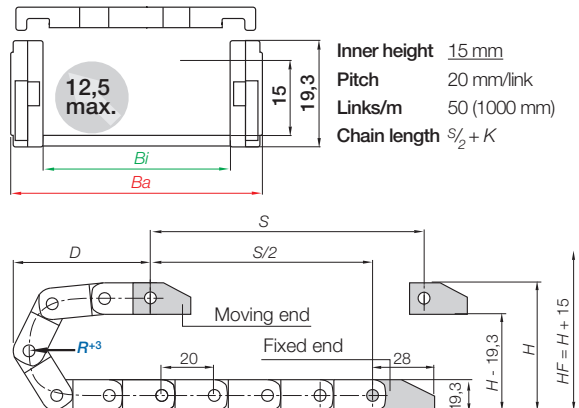
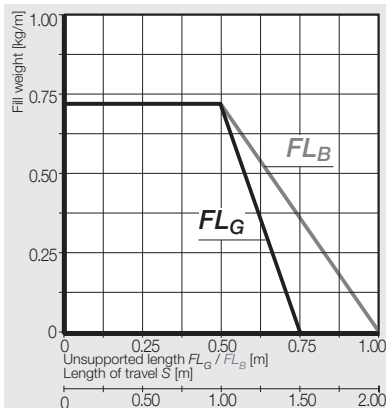

<i>R</i>	028	038	048
<i>H</i>	75	95	115
<i>D</i>	68	78	88
<i>K</i>	130	160	195

The required clearance height:  $H_F = H + 15$  mm (with 0,3 kg/m fill weight)

Mounting brackets, polymer one-piece | locking | More features ► [www.igus.eu/eu/09](http://www.igus.eu/eu/09)

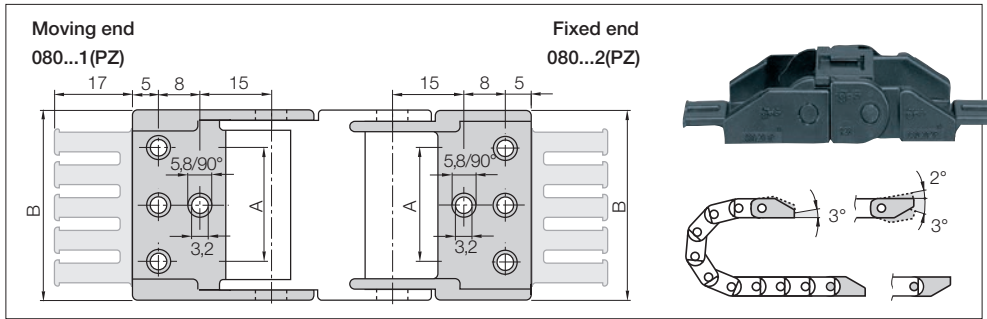

Width Index	 Part No. full set with tiewrap plates	Part No. full set without tiewrap plates	Dim A [mm]	Dim B [mm]	Number of teeth
10. ►	<b>080.10. 12PZ</b>	<b>080.10. 12</b>	–	18,2	1
16. ►	<b>080.16. 12PZ</b>	<b>080.16. 12</b>	–	24,2	2
20. ►	<b>080.20. 12PZ</b>	<b>080.20. 12</b>	–	28,2	2
30. ►	<b>080.30. 12PZ</b>	<b>080.30. 12</b>	22	38,2	3
40. ►	<b>080.40. 12PZ</b>	<b>080.40. 12</b>	32	48,2	4
50. ►	<b>080.50. 12PZ</b>	<b>080.50. 12</b>	42	58,2	5

Drilling pattern for width index: **080.10. - 080.20.** center bores only / **080.30. - 080.50.** all bores (see figure above)

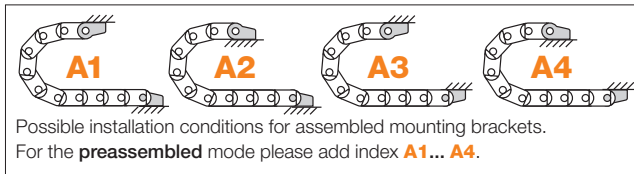

Part No. structure

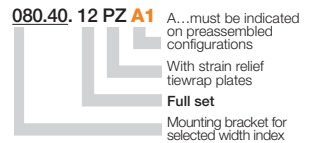

Interior separation

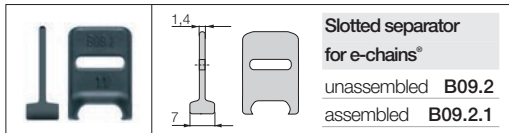

**Slotted separator B09.2**

is used when vertical and horizontal separation is required. Due to its slot, it allows basic vertical/horizontal shelving arrangements.

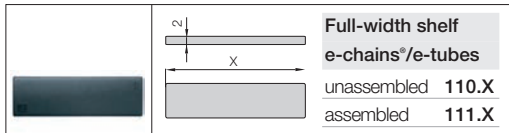

**Full-width shelf 110.X**

this option makes sense in applications with many thin cables with similar diameters. For a consequent subdivision.

Full-width shelves

Width X [mm]	unassembled	assembled	Width X [mm]	unassembled	assembled	Width X [mm]	unassembled	assembled
016	<b>110.16</b>	<b>111.16</b>	030	<b>110.30</b>	<b>111.30</b>	050	<b>110.50</b>	<b>111.50</b>
020	<b>110.20</b>	<b>111.20</b>	040	<b>110.40</b>	<b>111.40</b>			



ESD/ATEX permanently conductive e-chains® - Several widths with delivery from stock:

Inner widths **Bi 16 - 50**, radii **R 28 - 48**. Full ESD delivery program ► [www.igus.eu/eu/ESD](http://www.igus.eu/eu/ESD) 185



## e-tube | Series R09 | Zip-open along outer radius

e-tube zip-open along outer radius	<i>Bi</i> [mm]	<i>Ba</i> [mm]	<i>R</i> Bending radii [mm]	Weight [kg/m]
<b>R09.10</b> .R.0	10	18,2	048   075   100	≈ 0,23
<b>R09.16</b> .R.0	16	24,2	048   075   100	≈ 0,26
<b>R09.20</b> .R.0	20	28,2	048   075   100	≈ 0,27
<b>R09.30</b> .R.0	30	38,2	048   075   100	≈ 0,30
<b>R09.40</b> .R.0	40	48,2	048   075   100	≈ 0,33
<b>R09.50</b> .R.0	50	58,2	048   075   100	≈ 0,36

Supplement Part No. with required radius (*R*) Example: **R09.40.048.0**

## Dimensions

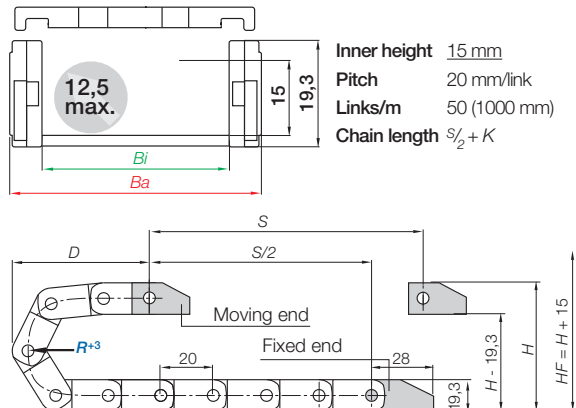
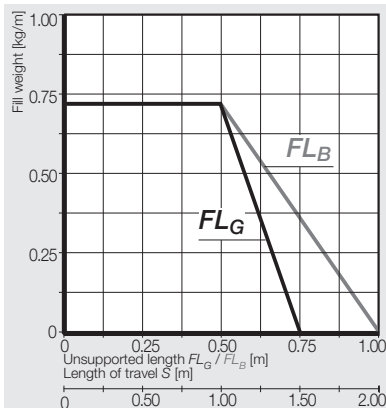

<b>R</b>	048	075	100
<b>H</b>	115	169	219
<b>D</b>	88	115	140
<b>K</b>	195	280	355

The required clearance height:  $H_F = H + 15$  mm (with 0,3 kg/m fill weight)

Mounting brackets, polymer one-piece | locking | More features ► [www.igus.eu/eu/R09](http://www.igus.eu/eu/R09)

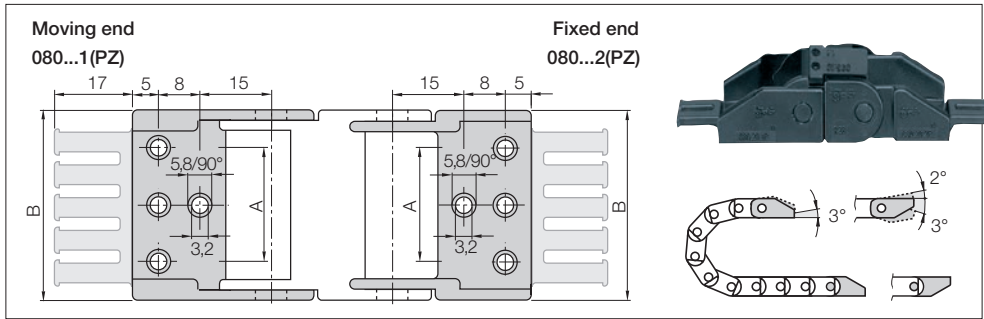

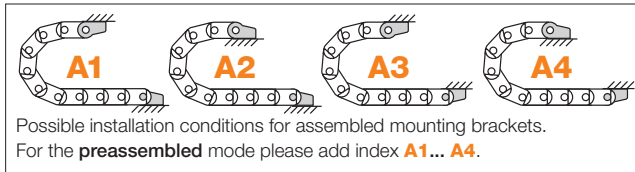

Width Index	 Part No. full set <b>with</b> tiewrap plates	Part No. full set <b>without</b> tiewrap plates	Dim A [mm]	Dim B [mm]	Number of teeth
10. ►	<b>080.10. 12PZ</b>	<b>080.10. 12</b>	–	18,2	1
16. ►	<b>080.16. 12PZ</b>	<b>080.16. 12</b>	–	24,2	2
20. ►	<b>080.20. 12PZ</b>	<b>080.20. 12</b>	–	28,2	2
30. ►	<b>080.30. 12PZ</b>	<b>080.30. 12</b>	22	38,2	3
40. ►	<b>080.40. 12PZ</b>	<b>080.40. 12</b>	32	48,2	4
50. ►	<b>080.50. 12PZ</b>	<b>080.50. 12</b>	42	58,2	5

Drilling pattern for width index: **080.10. - 080.20.** center bores only / **080.30. - 080.50.** all bores (see figure above)



**Part No. structure**

- 080.40. 12 PZ A1** A... must be indicated on preassembled configurations
-  With strain relief tiewrap plates
  - Full set**
  -  Mounting bracket for selected width index

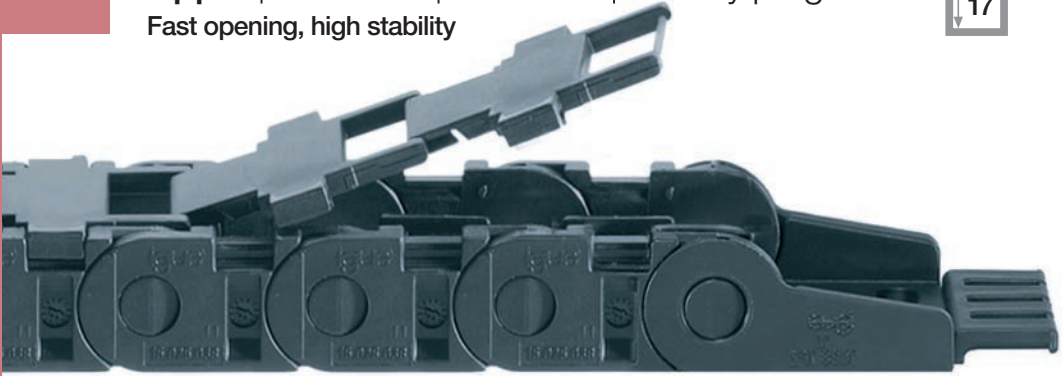

## e-chain® | Series 15 | Zip-open along outer radius

e-chain® zip-open along outer radius	<i>Bi</i> [mm]	<i>Ba</i> [mm]	<i>R</i> Bending radii [mm]	Weight [kg/m]
15. 015 . <i>R</i> .0	15	26	038   048   075   100   110   125   145   180	≈ 0,35
15. 025 . <i>R</i> .0	25	36	038   048   075   100   110   125   145   180	≈ 0,40
15. 038 . <i>R</i> .0	38	49	038   048   075   100   110   125   145   180	≈ 0,46
15. 050 . <i>R</i> .0	50	61	038   048   075   100   110   125   145   180	≈ 0,52
15. 5 . <i>R</i> .0	63	76	038   048   075   100   110   125   145   180	≈ 0,63
15. 6 . <i>R</i> .0	80	94	038   048   075   100   110   125   145   180	≈ 0,70
15. 7 . <i>R</i> .0	100	113	038   048   075   100   110   125   145   180	≈ 0,76

Before using this Series on long travels please consult igus®.

Supplement Part No. with required radius (*R*) Example: 15.025.038.0

## Dimensions

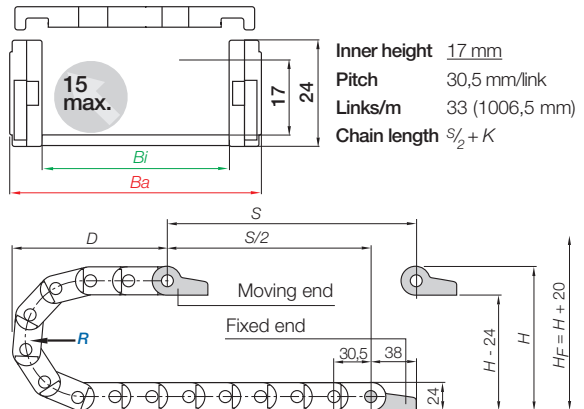
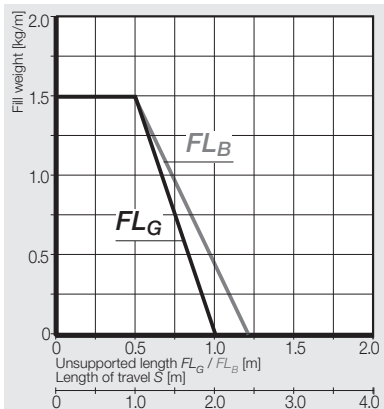

<i>R</i>	038	048	075	100	110	125	145	180
<i>H</i>	99	119	173	223	243	273	313	383
<i>D</i>	95	105	132	157	167	182	202	237
<i>K</i>	185	215	300	380	410	455	520	630

The required clearance height:  $H_F = H + 20$  mm (with 1,0 kg/m fill weight)



Mounting brackets, polymer one-piece | pivoting | locking

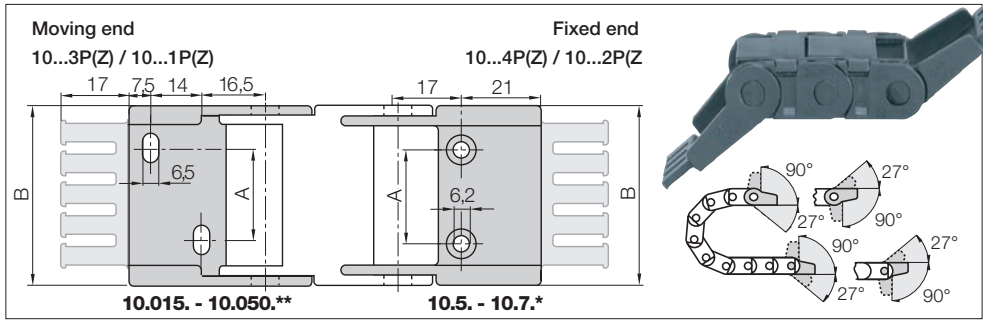

Width Index	Part No. full set pivoting:	Part No. full set locking:		Dim A [mm]	Dim B [mm]	
		with tiewrap plates	without tiewrap plates			with tiewrap plates
015.	1015.34PZ	1015.34P	1015.12PZ	1015.12P	–	25,5
025.	1025.34PZ	1025.34P	1025.12PZ	1025.12P	10	35,5
038.	1038.34PZ	1038.34P	1038.12PZ	1038.12P	23	48,5
050.	1050.34PZ	1050.34P	1050.12PZ	1050.12P	35	60,5
5.	105. 34PZ	105. 34P	105. 12PZ	105. 12P	48	75,0
6.	106. 34PZ	106. 34P	106. 12PZ	106. 12P	65	92,0
7.	107. 34PZ	107. 34P	107. 12PZ	107. 12P	85	112,0

\*\* Drilling pattern for width index: 15.015. - 15.050. see drawing left. Each valid for Moving end and Fixed end  
 \* Drilling pattern for width index: 15.5 - 15.7. see drawing right. Each valid for Moving end and Fixed end

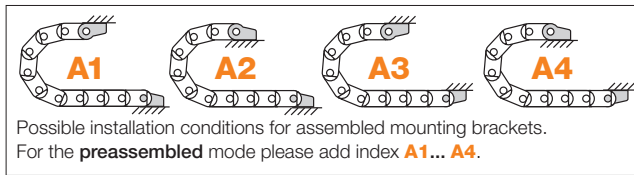

Part No. structure

<b>1025. 34 PZ A1</b>	A...must be indicated on preassembled configurations With strain relief tiewrap plates <b>Full set pivoting</b> Mounting bracket for selected width index
-----------------------	--

Interior separation

		<p><b>Slotted separator for e-chains®</b></p> <p>unassembled <b>153</b>                      assembled <b>154</b></p>
		<p><b>Side plate for e-chains®</b></p> <p>unassembled <b>155</b>                      assembled <b>156</b></p>
		<p><b>Full-width shelf for e-chains®</b></p> <p>unassembled <b>110.X</b>                      assembled <b>111.X</b></p>

**Slotted separator 153**

is used when vertical and horizontal separation is required. Due to its slot, it allows basic vertical/horizontal shelving arrangements.

**Side plate 155**

Side plate for use with full-width shelf 110.X and slotted separator 153.

**Full-width shelf 110.X**

this option makes sense in applications with many thin cables with similar diameters. For a consequent sub-division. Full-width shelves can be arranged at 3 different heights (in 5 mm increments).

Full-width shelves

Width X [mm]	unassembled	assembled	Width X [mm]	unassembled	assembled	Width X [mm]	unassembled	assembled
015	110.15	111.15	050	110.50	111.50	100	110.100	111.100
025	110.25	111.25	063	110.63	111.63			
038	110.38	111.38	080	110.80	111.80			

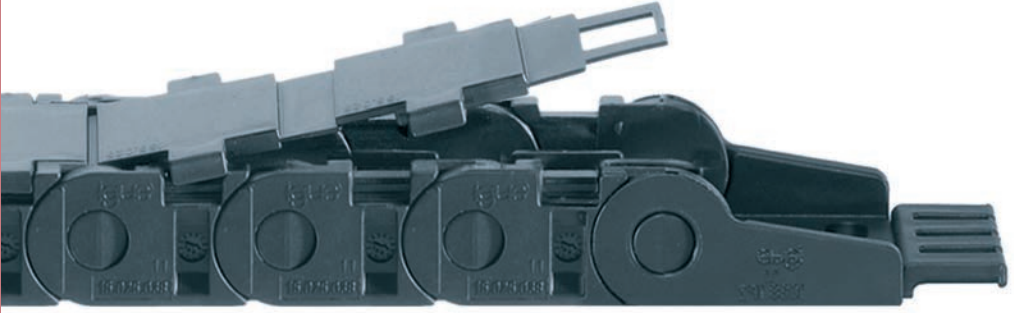

## e-tube | Series R15 | Zip-open along outer radius

e-tube zip-open along outer radius	<i>Bi</i> [mm]	<i>Ba</i> [mm]	<i>R</i> Bending radii [mm]	Weight [kg/m]
R15. <b>015</b> . <i>R</i> .0*	15	26	063   075   100   110   125   145   180	≈ 0,40
R15. <b>025</b> . <i>R</i> .0	25	36	063   075   100   110   125   145   180	≈ 0,45
R15. <b>038</b> . <i>R</i> .0	38	49	063   075   100   110   125   145   180	≈ 0,51
R15. <b>050</b> . <i>R</i> .0*	50	61	063   075   100   110   125   145   180	≈ 0,57
R15. <b>063</b> . <i>R</i> .0	63	76	063   075   100   110   125   145   180	≈ 0,68
R15. <b>080</b> . <i>R</i> .0	80	94	063   075   100   110   125   145   180	≈ 0,75
R15. <b>100</b> . <i>R</i> .0*	100	113	063   075   100   110   125   145   180	≈ 0,81

Before using this Series on long travels please consult igus®.

Supplement Part No. with required radius (*R*) Example: **R15.025.063.0**

## Dimensions

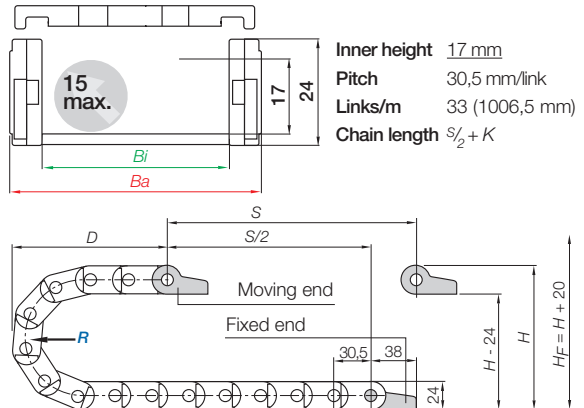
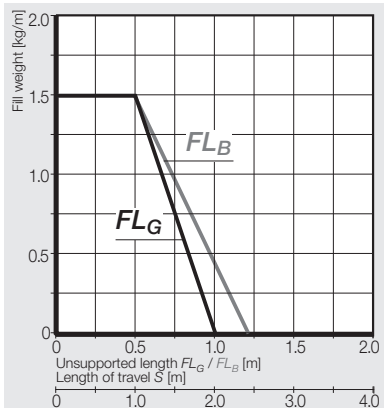

<i>R</i>	063	075	100	110	125	145	180
<i>H</i>	149	173	223	243	273	313	383
<i>D</i>	120	132	157	167	182	202	237
<i>K</i>	260	300	380	410	455	520	630

The required clearance height:  $H_F = H + 20$  mm (with 1,0 kg/m fill weight)





Mounting brackets, polymer one-piece | pivoting | locking

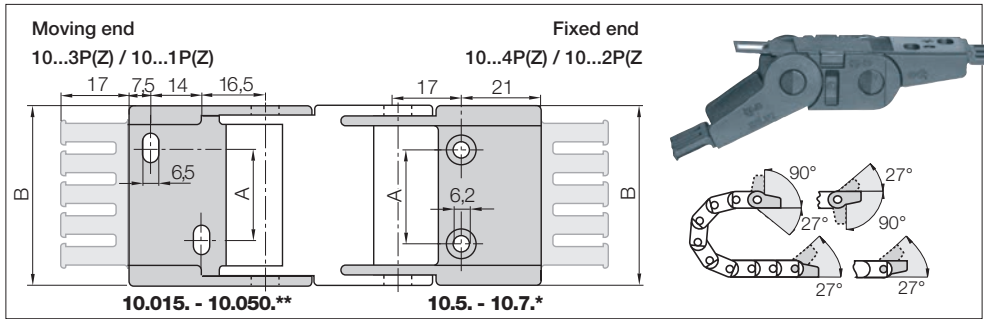

Width Index	Part No. full set <b>pivoting:</b> with tiewrap plates	without tiewrap plates	Part No. full set <b>locking:</b>		Dim A [mm]	Dim B [mm]	Number of teeth
			with tiewrap plates	without tiewrap plates			
015.	1015.34PZ	1015.34P	1015.12PZ	1015.12P	-	25,5	2
025.	1025.34PZ	1025.34P	1025.12PZ	1025.12P	10	35,5	3
038.	1038.34PZ	1038.34P	1038.12PZ	1038.12P	23	48,5	4
050.	1050.34PZ	1050.34P	1050.12PZ	1050.12P	35	60,5	5
5.	105. 34PZ	105. 34P	105. 12PZ	105. 12P	48	75,0	6
6.	106. 34PZ	106. 34P	106. 12PZ	106. 12P	65	92,0	8
7.	107. 34PZ	107. 34P	107. 12PZ	107. 12P	85	112,0	10

\*\* Drilling pattern for width index: 10.015. - 10.050. see drawing left. Each valid for Moving end and Fixed end

\* Drilling pattern for width index: 10.5. - 10.7. see drawing right. Each valid for Moving end and Fixed end

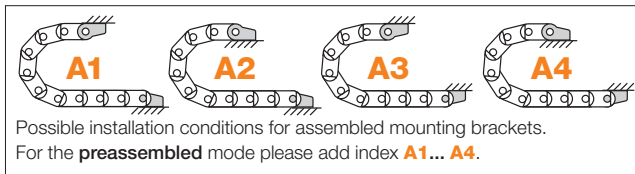

Part No. structure

<b>1025. 34 PZ A1</b>	A... must be indicated on preassembled configurations
	With strain relief tiewrap plates
	<b>Full set pivoting</b>
	Mounting bracket for selected width index

Interior separation

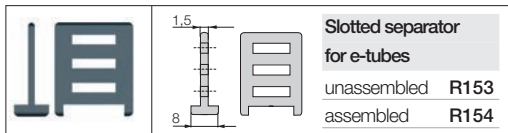

Slotted separator R153

is used when vertical and horizontal separation is required. Due to its slot, it allows basic vertical/horizontal shelving arrangements.

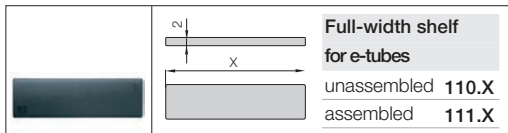

Full-width shelf 110.X

this option makes sense in applications with many thin cables with similar diameters. For a consequent subdivision. Full-width shelves can be arranged at 3 different heights (in 5 mm increments).

Full-width shelves

Width X [mm]	unassembled	assembled	Width X [mm]	unassembled	assembled
025	110.25	111.25	063	110.63	111.63
038	110.38	111.38	080	110.80	111.80

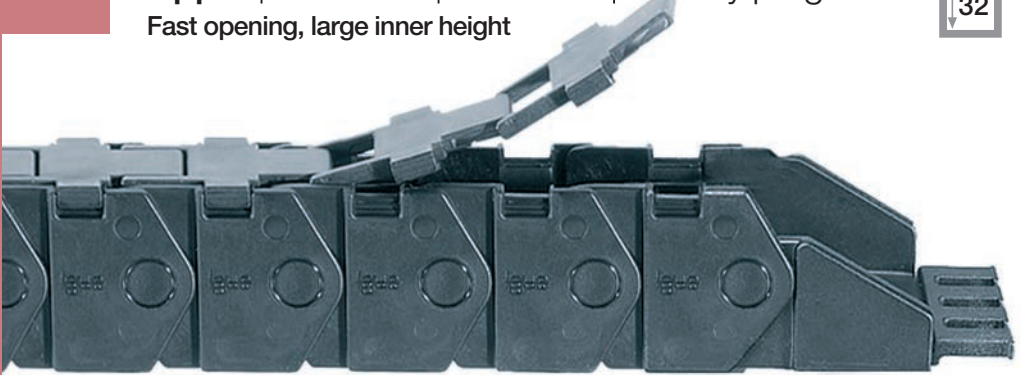

## e-chain® | Series 17 | Zip-open along outer radius

e-chain® zip-open along outer radius	<i>Bi</i> [mm]	<i>Ba</i> [mm]	<i>R</i> Bending radii [mm]	Weight [kg/m]
17. 1 .R.0	15	25,5	063   075   100   125	≈ 0,52
17. 2 .R.0	25	35,5	063   075   100   125	≈ 0,59
17. 3 .R.0	38	48,5	063   075   100   125	≈ 0,65
17. 4 .R.0	50	60,5	063   075   100   125	≈ 0,70
17. 5 .R.0	63	76	063   075   100   125	≈ 0,83
17. 6 .R.0	80	93	063   075   100   125	≈ 0,92
17. 7 .R.0	100	113	063   075   100   125	≈ 1,06

Supplyment Part No. with required radius (*R*) Example: 17.2.075.0

## Dimensions

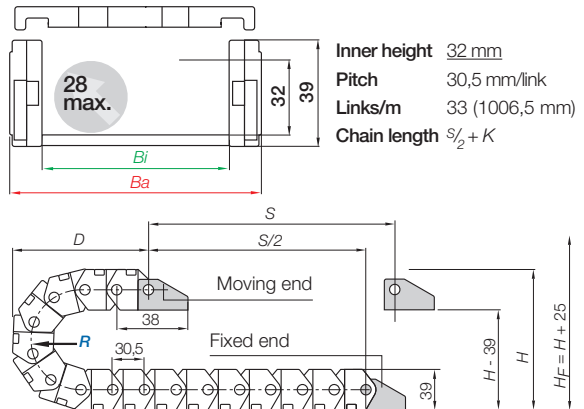
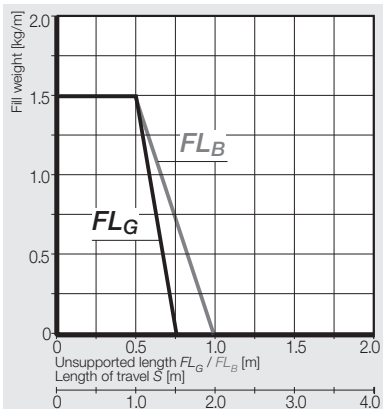

<i>R</i>	063	075	100	125
<i>H</i>	165	189	239	289
<i>D</i>	128	140	165	190
<i>K</i>	260	300	380	455

The required clearance height:  $H_F = H + 25$  mm (with 1,5 kg/m fill weight)

Mounting brackets, polymer one-piece | locking

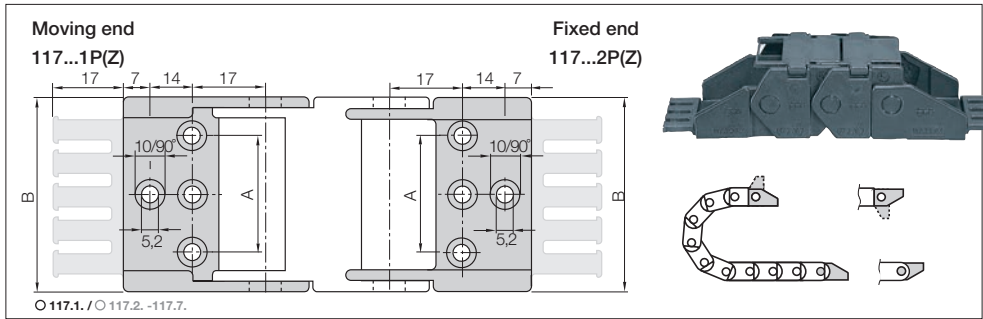

Width Index	Part No. full set with tiewrap plates	Part No. full set without tiewrap plates	Dim A [mm]	Dim B [mm]
1.	117.1.12PZ	117.1.12P	-	25,5
2.	117.2.12PZ	117.2.12P	12	35,5
3.	117.3.12PZ	117.3.12P	25	48,5
4.	117.4.12PZ	117.4.12P	37	60,5
5.	117.5.12PZ	117.5.12P	48	76
6.	117.6.12PZ	117.6.12P	65	93
7.	117.7.12PZ	117.7.12P	85	113

○ Drilling pattern for width index: 117.1. center bores only / ○ 117.2. - 117.7. outer bores only (see figure above)

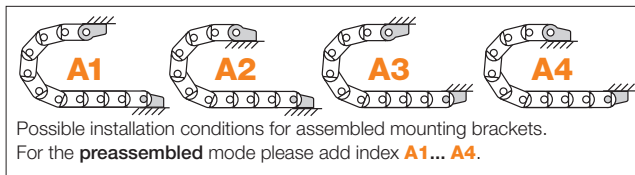

Part No. structure

Part No. structure	Description
117.2. 12 PZ A1	A... must be indicated on preassembled configurations With strain relief tiewrap plates Full set locking Mounting bracket for selected width index

Interior separation | Standard | Further interior separation elements ► www.igus.eu/eu/17

**Slotted separator for 17.1 up to 17.4**  
unassembled 171  
assembled 172

**Slotted separator 171** (17.1 up to 17.4) is used when vertical and horizontal separation is required. Due to its slot, it allows basic vertical/horizontal shelving arrangements.

**Slotted separator for 17.5 bis 17.7**  
unassembled 173  
assembled 174

**Slotted separator 173** (17.5 up to 17.7) is used when vertical and horizontal separation is required. Due to its slot, it allows basic vertical/horizontal shelving arrangements.

**Full-width shelf for e-chains®**  
unassembled 110.X  
assembled 111.X

**Full-width shelf 110.X** (for all widths) this option makes sense in applications with many thin cables with similar diameters. For a consequent subdivision. Full-width shelves can be arranged at 5 different heights (in 5 mm increments).

Full-width shelves

Width X [mm]	unassembled	assembled	Width X [mm]	unassembled	assembled	Width X [mm]	unassembled	assembled
015	110.15	111.15	050	110.50	111.50	100	110.100	111.100
025	110.25	111.25	063	110.63	111.63			
038	110.38	111.38	080	110.80	111.80			

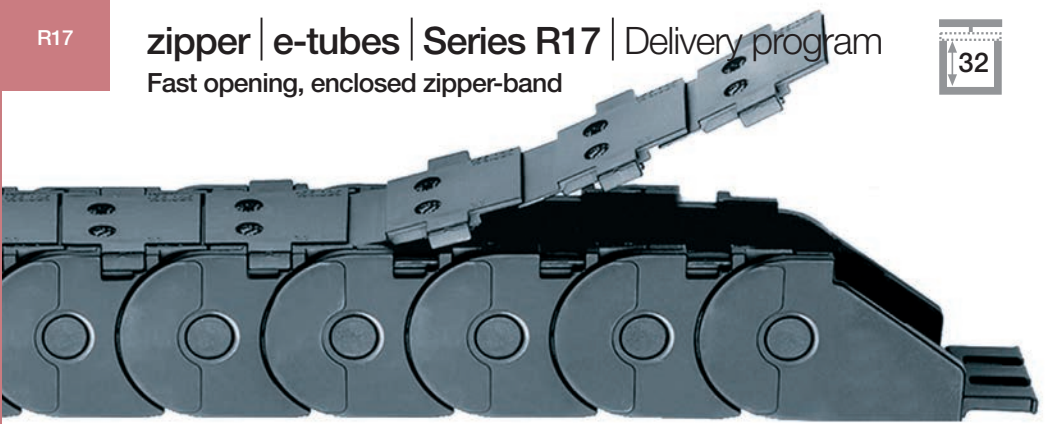

## e-chain® | Series R17 | Zip-open along outer radius

e-tube zip-open along outer radius	<i>Bi</i> [mm]	<i>Ba</i> [mm]	<i>R</i> Bending radii [mm]	Weight [kg/m]
R17. 015 .R.0	15	26	063   075   100   125	≈ 0,57
R17. 025 .R.0	25	36	063   075   100   125	≈ 0,64
R17. 063 .R.0	63	74	063   075   100   125	≈ 0,88

Supplement Part No. with required radius (*R*) Example: R17.015.063.0

## Dimensions

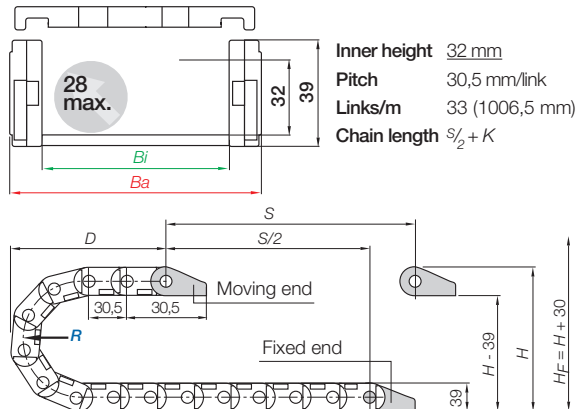
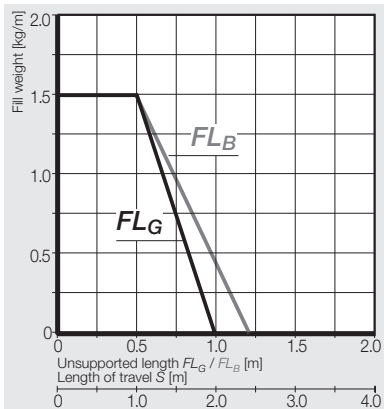

<i>R</i>	063	075	100	125
<i>H</i>	165	189	239	289
<i>D</i>	128	140	165	190
<i>K</i>	260	300	380	455

The required clearance height:  $H_F = H + 30$  mm (with 1,0 kg/m fill weight)

Mounting brackets, polymer one-piece | locking

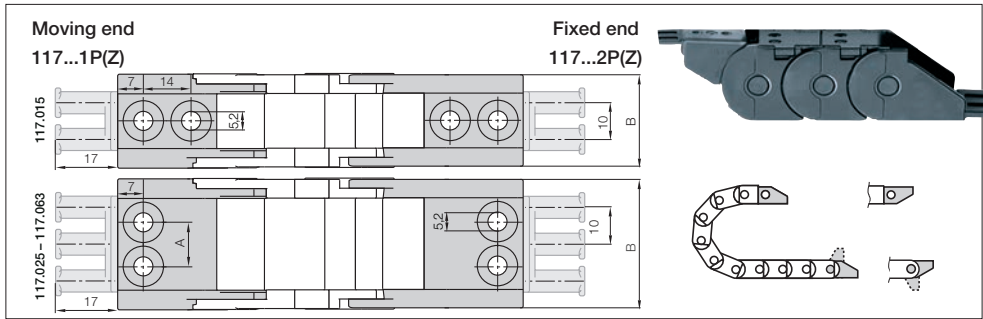

Width Index	 Part No. full set with tie-wrap plates	Part No. full set without tie-wrap plates	Dim A [mm]	Dim B [mm]	Number of teeth
015. ▶	<b>117.015.12PZ</b>	<b>117.015.12P</b>	–	25,7	2
025. ▶	<b>117.025.12PZ</b>	<b>117.025.12P</b>	12	35,7	3
063. ▶	<b>117.063.12PZ</b>	<b>117.063.12P</b>	48	73,7	6

Drilling pattern for width index: **117.015.** center bores only / **117.025. -117.7.** outer bores only (see figure above)

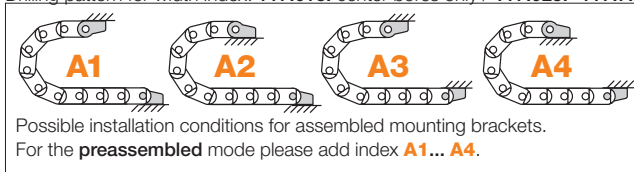

Part No. structure

**117.015. 12 PZ A1** A... must be indicated on preassembled configurations

- With strain relief tie-wrap plates
- Full set locking** Mounting bracket for selected width index

Possible installation conditions for assembled mounting brackets.  
For the **preassembled** mode please add index **A1... A4**.

Interior separation

**Slotted separator for e-tubes**  
unassembled **R171**  
assembled **R172**

Slotted separator R171

is used when vertical and horizontal separation is required. Due to its slot, it allows basic vertical/horizontal shelving arrangements.

**Full-width shelf for e-chains®**  
unassembled **110.X**  
assembled **111.X**

Full-width shelf 110.X

this option makes sense in applications with many thin cables with similar diameters. For a consequent subdivision. Full-width shelves can be arranged at 5 different heights (in 5 mm increments).

Width X [mm]	unassembled	assembled	Width X [mm]	unassembled	assembled
015	<b>110.15</b>	<b>111.15</b>	063	<b>110.63</b>	<b>111.63</b>
025	<b>110.25</b>	<b>111.25</b>			

Universal:  
Mounting bracket with  
strain relief option

Cost-effective:  
Very lightweight, low price

Smooth:  
Dirt-repellent exterior

Quiet:  
Small pitch for  
smooth running

Variations:  
Available as one-piece  
design, non snap-open  
(Series 03/04/045/05/06/08)

Variations:  
Available as two-piece  
design, snap-open  
along outer radius  
(Series B07/B09)

Variations:  
Available as one-  
piece design, snap-  
open along inner  
radius with film-hinge  
(Series 074/094)



**iF produkt design award**  
1989 igus® Series 05

## E2 micro - smallest inner heights and bending radii

**E2 micro** are very small, one-piece or two-piece (B07/B09), lightweight e-chains® ideal for high dynamic applications. E2 micro e-chains® are very cost effective and available in thousands of variations. igus® also offers a host of accessories and fixation options. "Upgrades" to openable versions are available for many types. In these cases they are interchangeable and offer more services as repair kits or new installations.

- e-chains® for limited space conditions
- One- and two-piece e-chains® available
- Smallest inner heights and bending radii
- Very lightweight, easy to assemble and cost-effective

### Typical industries and applications

- Models (micro e-chains®)
- Automatic doors
- Vehicles
- Measuring machines
- Electric equipment
- Handlings
- Pick and place robots
- General machinery



Clean room test  
upon request



42 dB(A) tested in igus® lab,  $v = 1,0$  m/s  
unsupported, Series 06.10.038.0



UL94-V2 classification - for Series  
03, 074, 094 (UL94-V0 upon request)



Electrically conductive  
ESD/ATEX versions upon request



# E2 micro | Selection Table

Series	Inner height <i>hi</i> [mm]	Inner width <i>Bi</i> [mm]	Outer width <i>Ba</i> [mm]	Outer height <i>ha</i> [mm]	Bending radius <i>R</i> [mm]	Unsupported max. length [m]	Page
--------	--------------------------------	-------------------------------	-------------------------------	--------------------------------	---------------------------------	--------------------------------	------



**E2 micro -  
One-piece e-chains®**  
One-piece, non snap-open

03	5,0	5 - 10	8,7 - 13,7	8,0	10 - 28	0,40	200
04	7,0	7 - 30	12,0 - 35,0	10,0	15 - 48	0,50	202
045	10,3	6 - 64	12,0 - 70,0	12,5	18 - 83	0,50	204
05	10,0	6 - 64	10,0 - 68,0	12,0	18 - 38	0,55	206
06	10,5	6 - 64	12,5 - 71,0	15,0	18 - 38	0,60	208
08	15,0	10 - 50	18,2 - 58,2	19,3	25 - 48	1,00	216

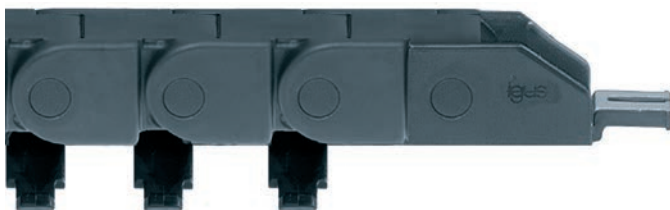

**E2 micro -  
One-piece e-chains®**  
Snap-open along inner  
radius with film-hinge

074	10,9	10	18,2	15,0	18 - 38	0,55	212
094	14,3	10	18,2	19,3	28 - 48	1,00	214



**E2 micro -  
Two-piece e-chains®**  
Snap-open along  
outer radius

B07	10,3	16 - 40	22,5 - 47,0	15,0	18 - 38	0,55	210
B09	14,3	16 - 40	24,2 - 48,2	19,3	28 - 48	1,00	218

## Next generation of micro e-chains® - System E2.1

● Lighter, more stable and easier to open ● Non snap-open or snapped open in the inner or outer radius ● In 2 inner heights available: 10 mm, 15 mm ● An e-chain®-opener is included with every Series E2.1 that can be opened, which significantly reduces installation time, especially for long lengths ● Interior separation and mounting brackets available **Further information** ► [www.igus.eu/E2.1open](http://www.igus.eu/E2.1open)



**New** in this catalog

## Technical Data



Gliding speed / acceleration (maximum) max. 3 [m/s] / max. 10 [m/s<sup>2</sup>]

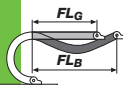

Speed / acceleration  $FL_G$  max. max. 20 [m/s] / max. 200 [m/s<sup>2</sup>]

Speed / acceleration  $FL_B$  max. max. 3 [m/s] / max. 6 [m/s<sup>2</sup>]



Material - permitted temperature °C, igumid G -40° up to +120° C

Material - permitted temperature °C, igumid NB (only Series 03, 074, 094) -40° up to +80° C



Flammability class: igumid G = VDE 0304 IIC UL94-HB / igumid NB = VDE 0304 IIC UL94-V2

■  $FL_G$  = with straight upper run ■  $FL_B$  = with permitted sag

## Installation methods overview, maximum travels

e-chain® Series	Unsupported application	Vertical hanging	Vertical standing	Side mounted unsupported	Rotary application	Zig-zag application
03	≤ 0,40 m	upon request	upon request	upon request	with rework	upon request
04	≤ 0,50 m	upon request	upon request	upon request	with rework	upon request
045	≤ 0,50 m	upon request	upon request	upon request	with rework	upon request
05	≤ 0,55 m	upon request	upon request	upon request	with rework	upon request
06	≤ 0,60 m	upon request	upon request	upon request	with rework	upon request
B07	≤ 0,55 m	upon request	upon request	upon request	with rework	upon request
074	≤ 0,55 m	upon request	upon request	upon request	with rework	upon request
094	≤ 1,00 m	upon request	upon request	upon request	with rework	upon request
08	≤ 1,00 m	upon request	upon request	upon request	with rework	upon request
B09	≤ 1,00 m	upon request	upon request	upon request	with rework	upon request



# E2 micro | Order keys and Options

## Options with order keys based on Series 08

	Standard	NC-Version - (no camber) without pretension	Reverse bending radius for circular movements	ESD / ATEX classified e-chains® 
Part No. Standard e-chains®		Part No. NC-Version e-chains®	Part No. RBR e-chains®	Part No. ESD-Material e-chains®
	08.50.R.0	08.50.R.0.NC	08.50.R1/R2.0	08.50.R.0.ESD
	Delivery from stock	Delivery time: upon request	Delivery time: upon request	Delivery time: upon request

## Order example | Order key and color options based on Series 08

Order example for complete e-chain® (1,0 m),  
color black, with mounting brackets and interior separation:

e-chain® (1,0 m)	Please indicate e-chain® length or number of links: 1,0 m or 50 links	08.50.038.0
+ Mounting brackets	1 set (+ tiwrap plates)	080.50.12PZ
+ Interior separation	with 2 separators assembled every 2 <sup>nd</sup> link	2 x B09.2.1
Order text: 1,0 m 08.50.038.0 + 080.50.12PZ + 2 x B09.2.1		

### Order key

e-chain®, non snap-open **08. 50. 038. 0**

Series / Type	
Width index (depends on B)	
Bending radius R	
Color index (standard black)	

08.50.038.0 = e-chain®, one-piece, non snap-open,  
inner width **B** 50 mm, radius **R** 38 mm, color black

### General igus® color options for e-chains® and e-tubes

Color	Order index	Color	Order index
<b>Black</b> Standard, from stock!	<b>.0</b>	<b>White</b> special color	<b>.1</b>
<b>Slate grey</b> only ESD material	<b>.ESD</b>	<b>Gray white</b> special color	<b>.1S</b>
<b>Gray brown</b> only HT material	<b>.HT</b>	<b>Orange</b> special color	<b>.2</b>
<b>Gray</b> special color only e-chains®	<b>.3</b>	<b>Yellow</b> special color	<b>.4</b>
<b>Dusty grey</b> special color only e-tubes	<b>.31</b>	<b>Light grey</b> special color	<b>.14</b>

**Black e-chains® available from stock!**  
Delivery time for special colors: upon request



## Series 03 | One-piece, non snap-open e-chain®

e-chain* non snap-open	<i>Bi</i> [mm]	<i>Ba</i> [mm]	<i>R</i> Bending radii [mm]	Weight [kg/m]
03. 05 .R.0	5	8,7	010   012   015   018   028	≈ 0,04
03. 07 .R.0	7	10,7	010   012   015   018   028	≈ 0,05
03. 10 .R.0	10	13,7	010   012   015   018   028	≈ 0,06

Supplement Part No. with required radius (*R*) Example: **03.05.028.0**

## Dimensions

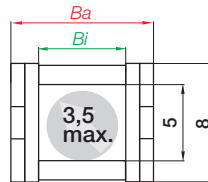
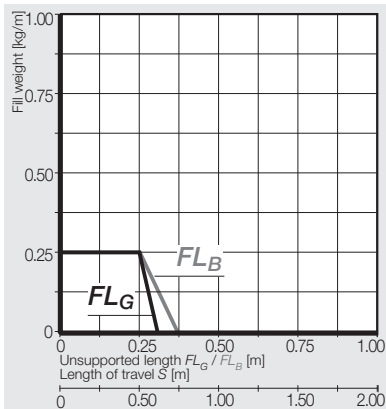

Inner height 5 mm  
Pitch 10 mm/link  
Links/m 100 (1000 mm)  
Chain length  $S/2 + K$

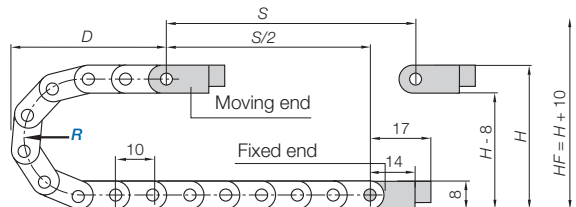

<i>R</i>	010	012	015	018	028
<i>H</i>	28	32	38	44	64
<i>D</i>	29	31	34	37	47
<i>K</i>	55	60	70	80	110

The required clearance height:  $H_F = H + 10$  mm (with 0,1 kg/m fill weight)

Mounting brackets, polymer one-piece | pivoting

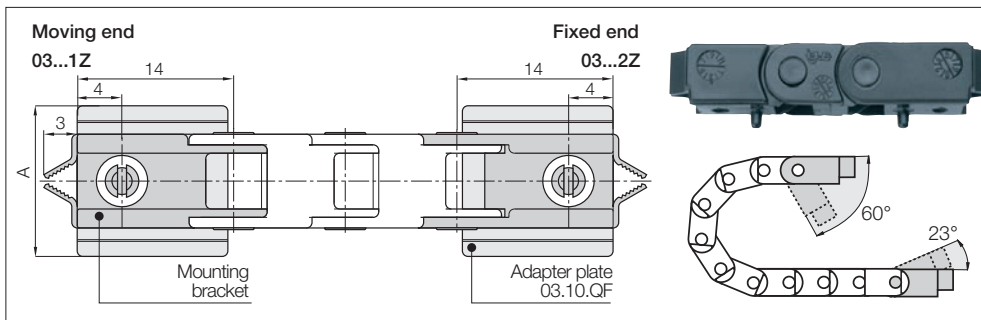

Width Index	Part No.  full set	Dim A [mm]
.05. ▶	<b>03.05. 12Z</b>	8,7
.07. ▶	<b>03.07. 12Z</b>	10,7
.10. ▶	<b>03.10. 12Z</b>	13,7

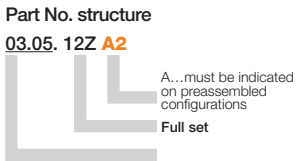
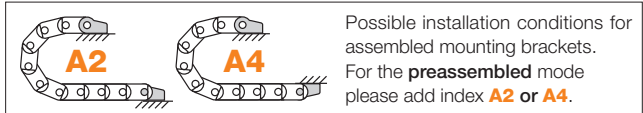

Additional Features

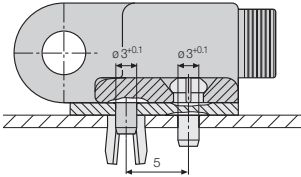

**Adapter plate for rapid installation: for all sizes of Part No. 03.10.QF**

The adapter has broken edges so that it can be adapted to the respective chain width. It is not absolutely necessary when attaching the mounting brackets. The mounting brackets can also be screwed on without the adapter plate.



### Series 04 | One-piece, non snap-open e-chain®

e-chain* non snap-open	<i>Bi</i> [mm]	<i>Ba</i> [mm]	<i>R</i> Bending radii [mm]	Weight [kg/m]
04. 07 .R.0	7	12	015   018   028   038   048	≈ 0,07
04. 10 .R.0	10	15	015   018   028   038   048	≈ 0,08
04. 16 .R.0	16	21	015   018   028   038   048	≈ 0,09
04. 20 .R.0	20	25	015   018   028   038   048	≈ 0,10
04. 30 .R.0	30	35	015   018   028   038   048	≈ 0,11

Supplement Part No. with required radius (*R*) Example: **04.10.028.0**

### Dimensions

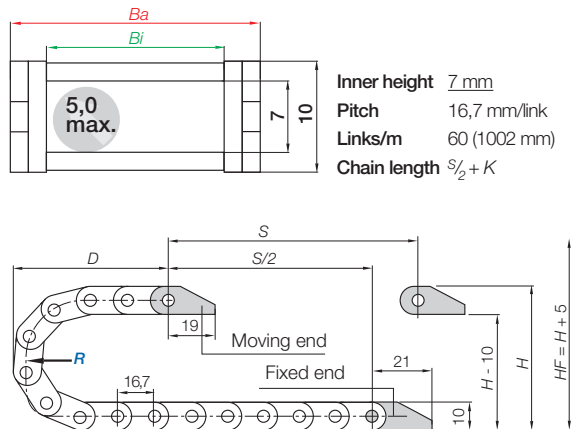
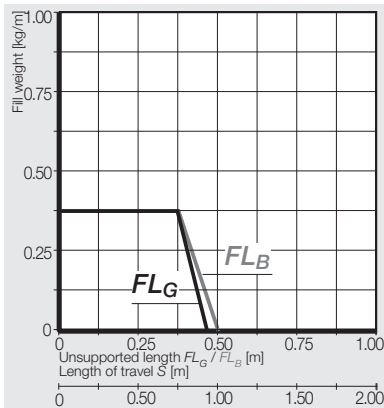

<i>R</i>	015	018	028	038	048
<i>H</i>	40	46	66	86	106
<i>D</i>	45	48	58	68	78
<i>K</i>	85	90	125	155	185

The required clearance height:  $H_f = H + 5$  mm (with 0,1 kg/m fill weight)

Mounting brackets, polymer one-piece | pivoting | More features ► [www.igus.eu/eu/04](http://www.igus.eu/eu/04)

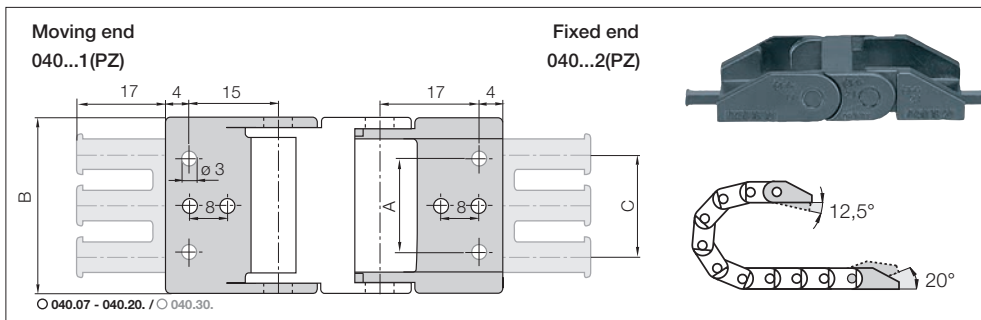

Width Index	Part No. full set with tiewrap plates	Part No. full set without tiewrap plates	Dim A [mm]	Dim B [mm]	Dim C [mm]	Number of teeth
.07. ►	040.07.12PZ	040.07.12	-	12	-	1
.10. ►	040.10.12PZ	040.10.12	-	15	-	1
.16. ►	040.16.12PZ	040.16.12	-	21	10	2
.20. ►	040.20.12PZ	040.20.12	-	25	10	2
.30. ►	040.30.12PZ	040.30.12	22	35	20	3

○ Drilling pattern for width index: 040.07 - 040.20. center bores only / ○ 040.30. outer bores only (see figure above)

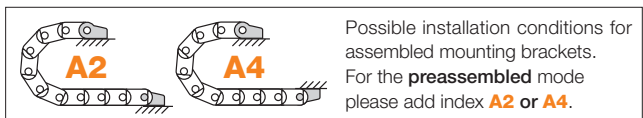

Part No. structure  
**040.07. 12 PZ A2** A...must be indicated on preassembled configurations  
 With strain relief tiewrap plates  
**Full set**  
 Mounting bracket for selected width index

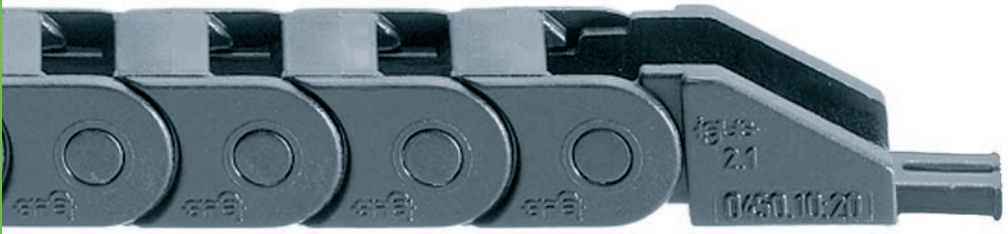

## Series 045 | One-piece, non snap-open e-chain®

e-chain* non snap-open	<i>Bi</i> [mm]	<i>Ba</i> [mm]	<i>R</i> Bending radii [mm]	Weight [kg/m]
045.06 .R.0	6	12	018  028  038  083*	≈ 0,09
045.10 .R.0	10	16	018  028  038  083*	≈ 0,10
045.16 .R.0	16	22	018  028  038  083*	≈ 0,11
045.20 .R.0	20	26	018  028  038  083	≈ 0,13
045.30 .R.0	30	36	018  028  038  083*	≈ 0,16
045.64 .R.0	64	70	018  028  038  083*	≈ 0,19

\*Radius 083 only for Series 045.20 - for other widths available upon request, please consult igus® for delivery time

Supplement Part No. with required radius (*R*) Example: 045.10.028.0

## Dimensions

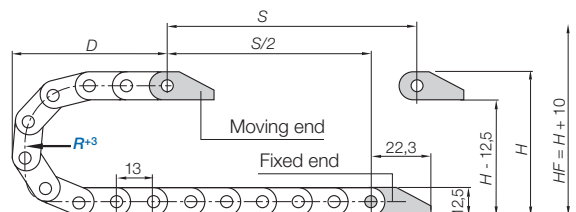
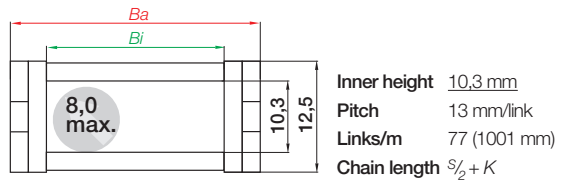
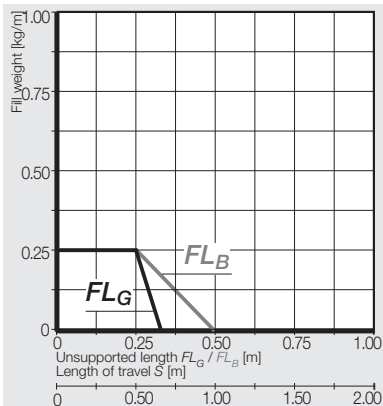

<i>R</i>	018	028	038	083*
<i>H</i>	48,5	68,5	88,5	178,5
<i>D</i>	44	54	64	109
<i>K</i>	85	115	150	290

The required clearance height:  $H_F = H + 10$  mm (with 0,2 kg/m fill weight)

\*Radius 083 only for Series 045.20 - for other widths available upon request, please consult igus® for delivery time

Mounting brackets, polymer one-piece | one side pivoting

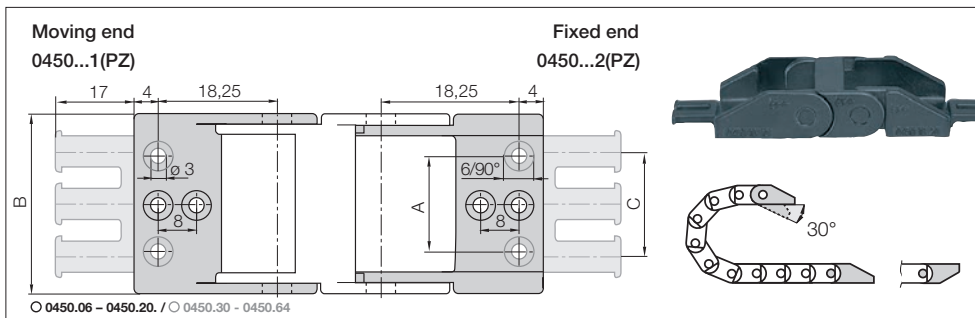

Width Index	Part No. full set with tiewrap plates	Part No. full set without tiewrap plates	Dim A [mm]	Dim B [mm]	Dim C [mm]	Number of teeth
.06.	0450.06.12PZ	0450.06.12	-	12	-	1
.10.	0450.10.12PZ	0450.10.12	-	16	-	1
.16.	0450.16.12PZ	0450.16.12	-	22	10	2
.20.	0450.20.12PZ	0450.20.12	-	26	10	2
.30.	0450.30.12PZ	0450.30.12	22	36	20	3
.64.	0450.64.12PZ	0450.64.12	56	70	50	6

Mounting bracket with strain relief tiewrap plate has reductions of  $\varnothing 3$  mm /  $\varnothing 6$  mm, 90°.

Mounting bracket without strain relief tiewrap plate only has holes of  $\varnothing 3$  mm.

○ Drilling pattern for width index: 0450.06 - 0450.20. center bores only / ○ 0450.30. - 0450.64. outer bores only (see figure above)

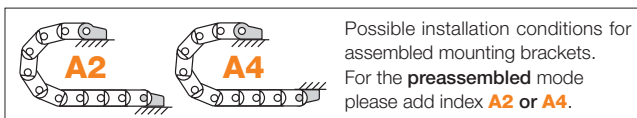

Part No. structure

0450.10. 12 PZ **A2**





## Series 05 | One-piece, non snap-open e-chain®

e-chain* non snap-open	<i>Bi</i> [mm]	<i>Ba</i> [mm]	<i>R</i> Bending radii [mm]	Weight [kg/m]
05. 06 .R.0	6	10	018   028   038	≈ 0,06
05. 10 .R.0	10	14	018   028   038	≈ 0,07
05. 16 .R.0	16	20	018   028   038	≈ 0,07
05. 20 .R.0	20	24	018   028   038	≈ 0,08
05. 30 .R.0	30	34	018   028   038	≈ 0,09
05. 64 .R.0	64	68	018   028   038	≈ 0,19

Supplement Part No. with required radius (*R*) Example: 05.10.028.0

## Dimensions

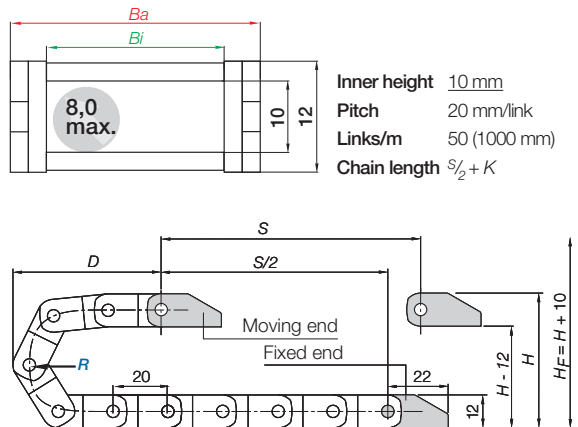
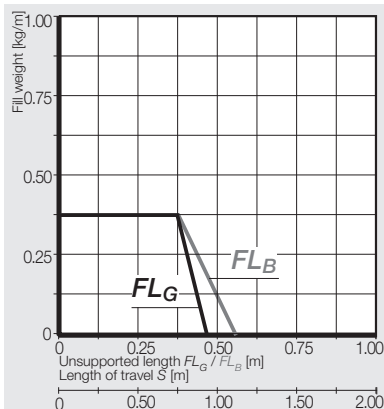

<i>R</i>	018	028	038
<i>H</i>	48	68	88
<i>D</i>	54	64	74
<i>K</i>	100	130	160

The required clearance height:  $H_F = H + 10$  mm (with 0,2 kg/m fill weight)



Mounting brackets, polymer one-piece | one side pivoting

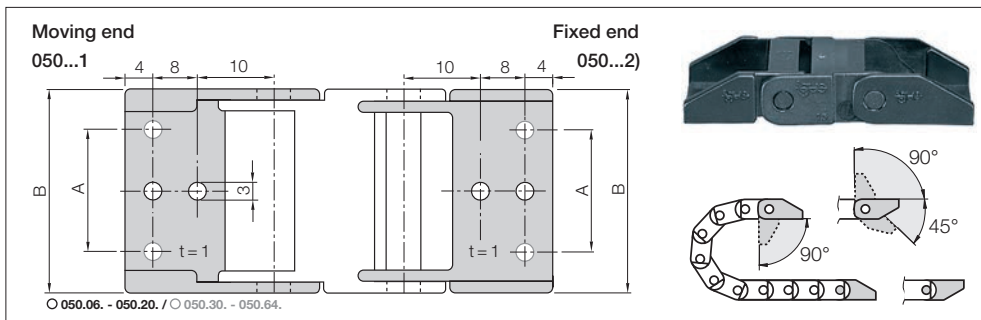

Width Index	Part No. full set	Dim A [mm]	Dim B [mm]	Number of teeth
.06.	050.06.12	-	10,7	-
.10.	050.10.12	-	14,7	-
.16.	050.16.12	-	20,7	-
.20.	050.20.12	-	24,7	-
.30.	050.30.12	22	34,7	-
.64.	050.64.12	56	68,7	-

○ Drilling pattern for width index: 050.06 - 050.20. center bores only / ○ 050.30 - 050.64. outer bores only (see figure above)

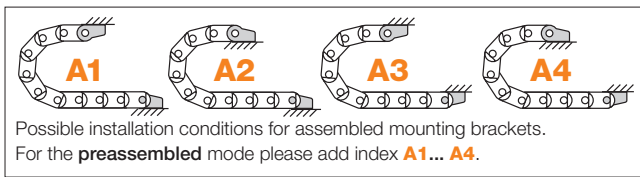

Part No. structure  
050.10. 12 **A1**

A...must be indicated on preassembled configurations  
**Full set**  
Mounting bracket for selected width index



## Series 06 | One-piece, non snap-open e-chain®

e-chain* non snap-open	<i>Bi</i> [mm]	<i>Ba</i> [mm]	<i>R</i> Bending radii [mm]	Weight [kg/m]
06. 06 .R.0	6	12,5	018   028   038	≈ 0,13
06. 10 .R.0	10	16,5	018   028   038	≈ 0,14
06. 16 .R.0	16	22,5	018   028   038	≈ 0,16
06. 20 .R.0	20	27	018   028   038	≈ 0,17
06. 30 .R.0	30	37	018   028   038	≈ 0,20
06. 40 .R.0	40	47	018   028   038	≈ 0,23
06. 50 .R.0	50	57	018   028   038	≈ 0,26
06. 64 .R.0	64	71	018   028   038	≈ 0,30

Supplement Part No. with required radius (*R*) Example: **06.10.028.0**

## Dimensions

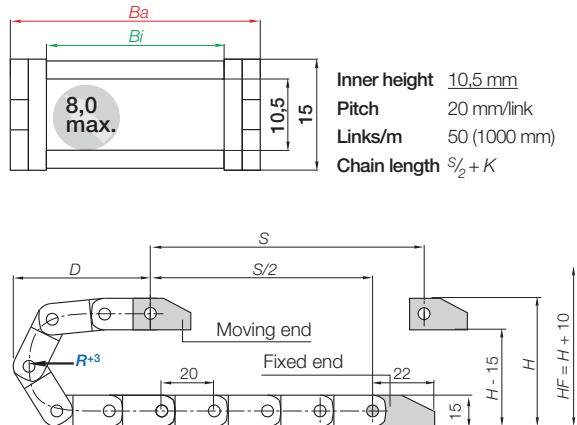
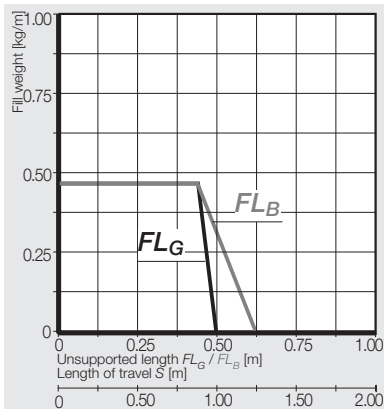

<i>R</i>	018	028	038
<i>H</i>	51	71	91
<i>D</i>	56	66	76
<i>K</i>	100	130	160

The required clearance height:  $H_F = H + 10$  mm (with 0,2 kg/m fill weight)

Mounting brackets, polymer one-piece | locking | More features ▶ [www.igus.eu/eu/06](http://www.igus.eu/eu/06)

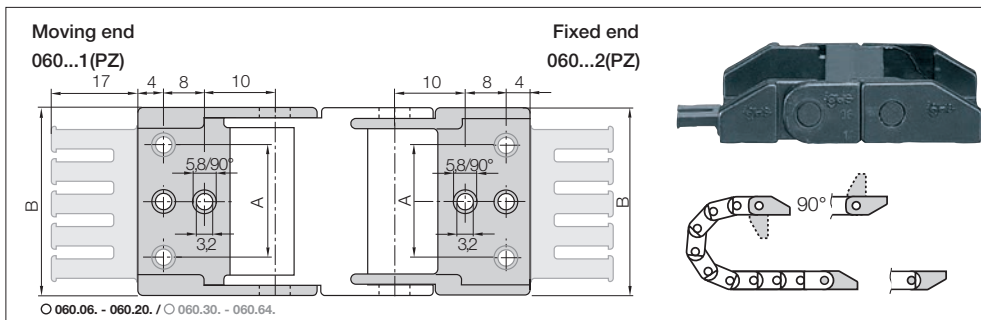

Width Index	Part No. full set with tiewrap plates	Part No. full set without tiewrap plates	Dim A [mm]	Dim B [mm]	Number of teeth
.06. ▶	060.06.12PZ	060.06.12	-	12,5	1
.10. ▶	060.10.12PZ	060.10.12	-	16,5	1
.16. ▶	060.16.12PZ	060.16.12	-	22,5	2
.20. ▶	060.20.12PZ	060.20.12	-	27,0	2
.30. ▶	060.30.12PZ	060.30.12	22	37,0	3
.40. ▶	060.40.12PZ	060.40.12	32	47,0	4
.50. ▶	060.50.12PZ	060.50.12	42	57,0	5
.64. ▶	060.64.12PZ	060.64.12	56	71,0	6

○ Drilling pattern for width index: 060.06. - 060.20. center bores only / ○ 060.30. - 060.64. outer bores only (see figure above)

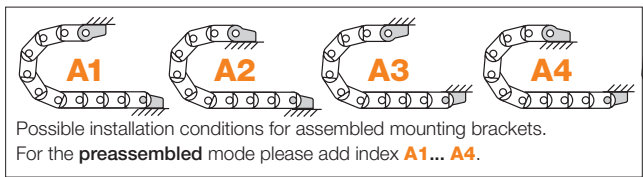

**Part No. structure**  
**060.10. 12 PZ A1** A... must be indicated on preassembled configurations  
 With strain relief tiewrap plates  
**Full set**  
 Mounting bracket for selected width index



## Series B07 | Two-piece link design, snap-open along outer radius

Snap-open along outer radius	<i>Bi</i> [mm]	<i>Ba</i> [mm]	<i>R</i> Bending radii [mm]	Weight [kg/m]
<b>B07. 16 .R.0</b>	16	22,5	018   028   038	≈ 0,16
<b>B07. 20 .R.0</b>	20	27	018   028   038	≈ 0,17
<b>B07. 30 .R.0</b>	30	37	018   028   038	≈ 0,20
<b>B07. 40 .R.0</b>	40	47	018   028   038	≈ 0,23

Supplement Part No. with required radius (*R*) Example: **B07.40.038.0**

## Dimensions

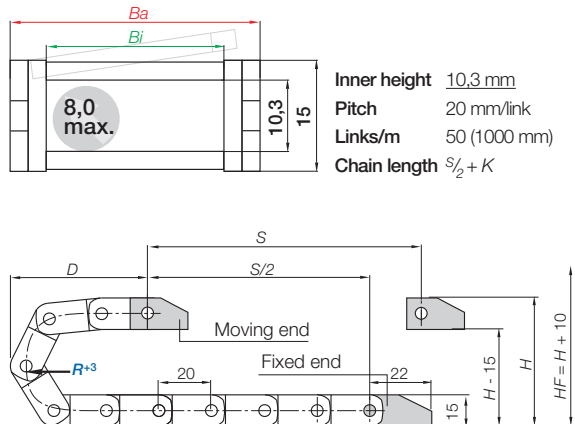
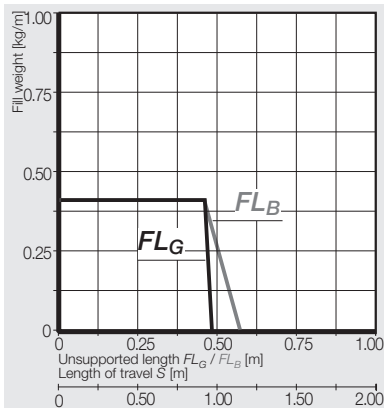

<i>R</i>	018	028	038
<i>H</i>	51	71	91
<i>D</i>	56	66	76
<i>K</i>	100	130	160

The required clearance height:  $H_F = H + 10$  mm (with 0,2 kg/m fill weight)

Mounting brackets, polymer one-piece | locking | More features ► [www.igus.eu/eu/B07](http://www.igus.eu/eu/B07)

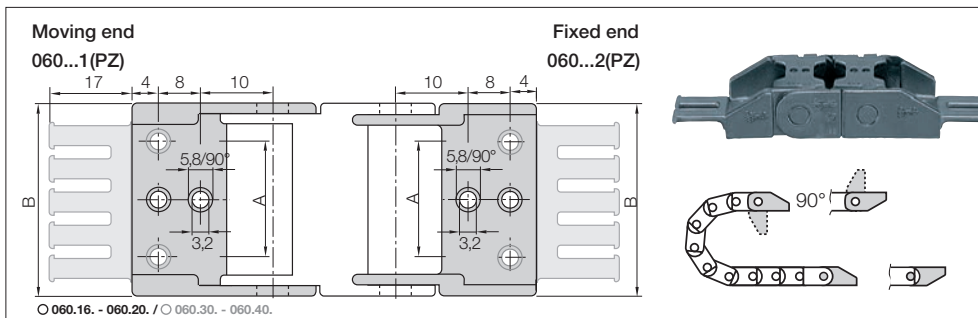

Width Index	Part No. full set with tiewrap plates	Part No. full set without tiewrap plates	Dim A [mm]	Dim B [mm]	Number of teeth
.16. ►	060.16. 12PZ	060.16. 12	-	22,5	2
.20. ►	060.20. 12PZ	060.20. 12	-	27,0	2
.30. ►	060.30. 12PZ	060.30. 12	22	37,0	3
.40. ►	060.40. 12PZ	060.40. 12	32	47,0	4

○ Drilling pattern for width index: 060.16. - 060.20. center bores only / ○ 060.30. - 060.40. outer bores only (see figure above)

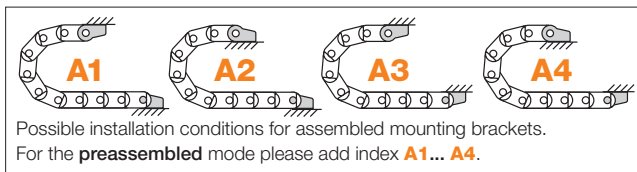

Part No. structure

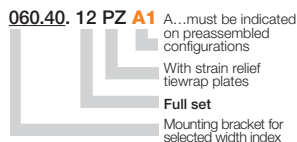

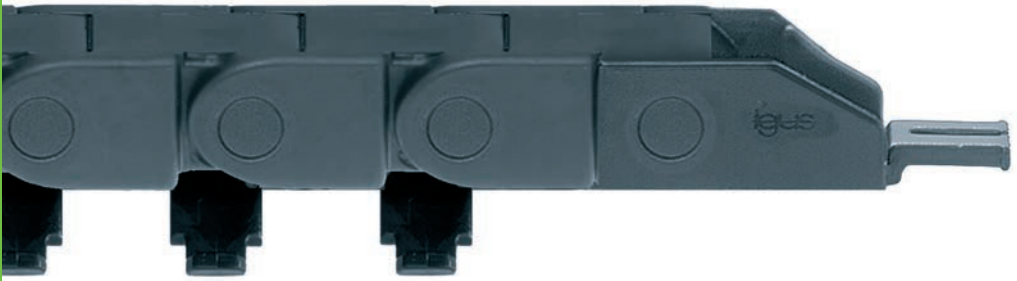

## Series 074 | One-piece, snap-open along inner radius with film-hinge

Snap-open along inner radius	<i>Bi</i> [mm]	<i>Ba</i> [mm]	<i>R</i> Bending radii [mm]	Weight [kg/m]
074. 10 .R.0	10	18,2	018   028   038	≈ 0,15
074. 16 .R.0*	16	22,5	018   028   038	≈ 0,16
074. 20 .R.0*	20	27	018   028   038	≈ 0,17
074. 30 .R.0*	30	37	018   028   038	≈ 0,20
074. 40 .R.0*	40	47	018   028   038	≈ 0,23

\*Width available upon request, please consult igus\* for delivery time

Supplement Part No. with required radius (*R*) Example: 074.10.018.0

## Dimensions

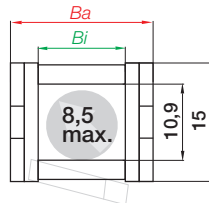
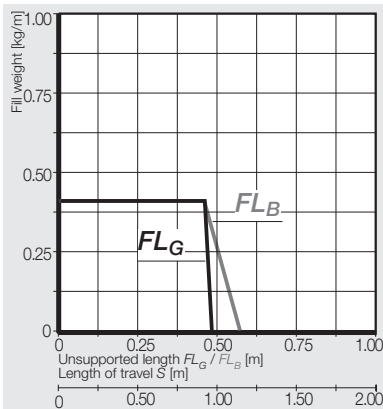

Inner height 10,9 mm  
Pitch 20 mm/link  
Links/m 50 (1000 mm)  
Chain length  $S/2 + K$

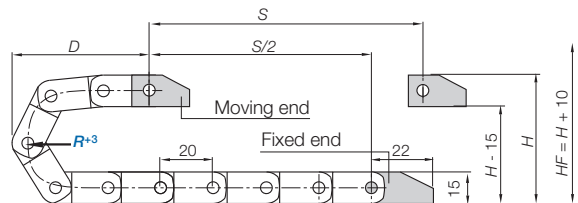

<i>R</i>	018	028	038
<i>H</i>	51	71	91
<i>D</i>	56	66	76
<i>K</i>	100	130	160

The required clearance height:  $H_F = H + 10$  mm (with 0,2 kg/m fill weight)

Mounting brackets, polymer one-piece | locking | More features ► [www.igus.eu/eu/074](http://www.igus.eu/eu/074)

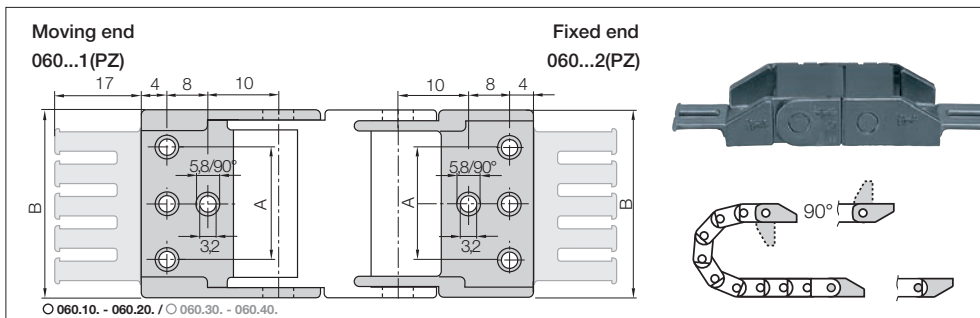

Width Index	 Part No. full set with tiewrap plates	Part No. full set without tiewrap plates	Dim A [mm]	Dim B [mm]	Number of teeth
.10. ►	<b>060.10. 12PZ</b>	<b>060.10. 12</b>	-	16,5	1
.16. ►	<b>060.16. 12PZ*</b>	<b>060.16. 12*</b>	-	22,5	2
.20. ►	<b>060.20. 12PZ*</b>	<b>060.20. 12*</b>	-	27	2
.30. ►	<b>060.30. 12PZ*</b>	<b>060.30. 12*</b>	22	37	3
.40. ►	<b>060.40. 12PZ*</b>	<b>060.40. 12*</b>	32	47	4

\*Width available upon request, please consult igus® for delivery time

○ Drilling pattern for width index: **060.10. - 060.20.** center bores only / ○ **060.30. - 060.40.** outer bores only (see figure above)

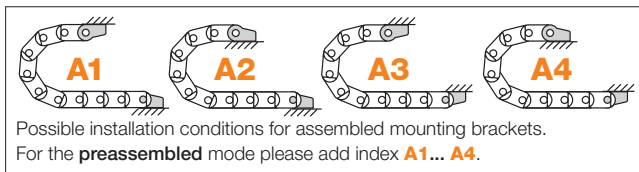

**Part No. structure**

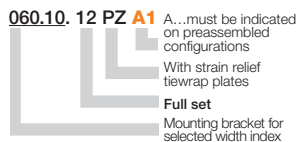

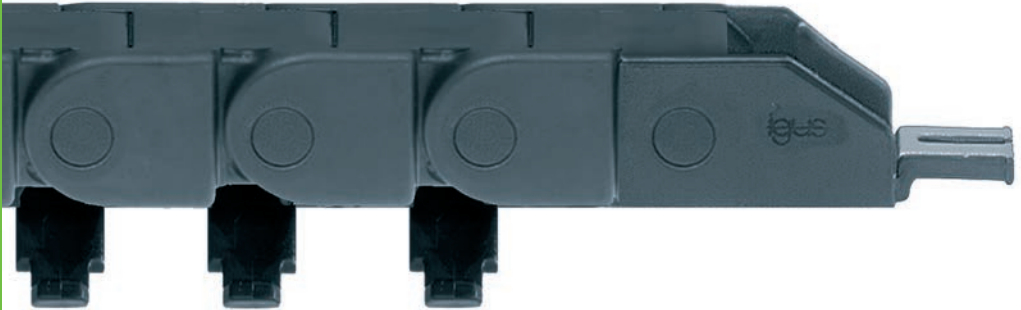

## Series 094 | One-piece, snap-open along inner radius with film-hinge

Snap-open along inner radius	<i>Bi</i> [mm]	<i>Ba</i> [mm]	<i>R</i> Bending radii [mm]	Weight [kg/m]
094. 10 . <i>R</i> .0	10	18,2	028   038   048	≈ 0,23
094. 16 . <i>R</i> .0*	16	24,2	028   038   048	≈ 0,24
094. 20 . <i>R</i> .0*	20	28,2	028   038   048	≈ 0,25
094. 30 . <i>R</i> .0*	30	38,2	028   038   048	≈ 0,28
094. 40 . <i>R</i> .0*	40	48,2	028   038   048	≈ 0,31

\*Width available upon request, please consult igus\* for delivery time

Supplement Part No. with required radius (*R*) Example: 094.10.028.0

## Dimensions

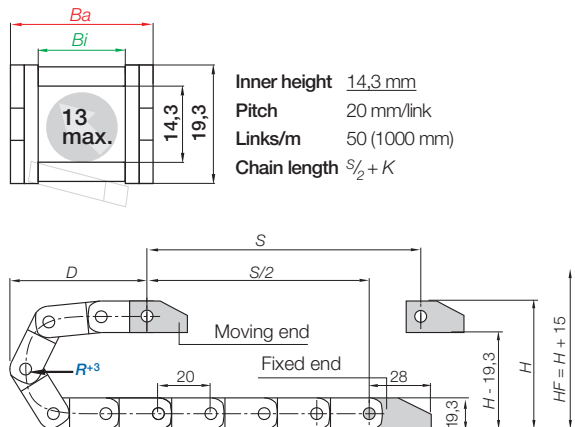
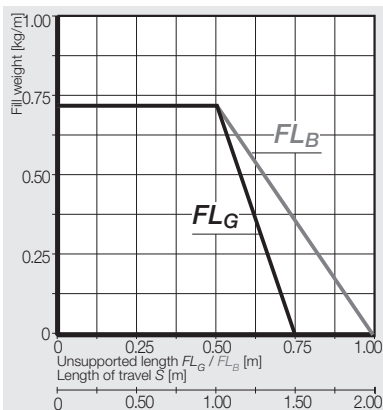



<i>R</i>	028	038	048
<i>H</i>	75	95	115
<i>D</i>	68	78	88
<i>K</i>	130	160	195

The required clearance height:  $H_F = H + 15$  mm (with 0,3 kg/m fill weight)

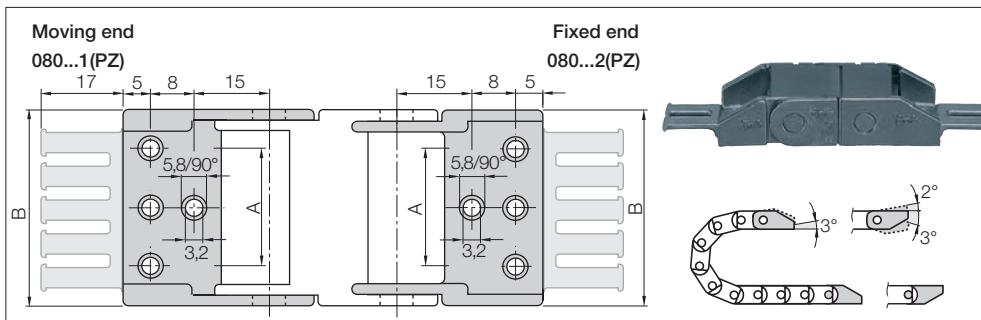

Mounting brackets, polymer one-piece | locking | More features ► [www.igus.eu/eu/094](http://www.igus.eu/eu/094)



Width Index	 Part No. full set with tiewrap plates	Part No. full set without tiewrap plates	Dim A [mm]	Dim B [mm]	Number of teeth
.10. ►	<b>080.10. 12PZ</b>	<b>080.10. 12</b>	–	18,2	1
.16. ►	<b>080.16. 12PZ*</b>	<b>080.16. 12*</b>	–	24,2	2
.20. ►	<b>080.20. 12PZ*</b>	<b>080.20. 12*</b>	–	28,2	2
.30. ►	<b>080.30. 12PZ*</b>	<b>080.30. 12*</b>	22	38,2	3
.40. ►	<b>080.40. 12PZ*</b>	<b>080.40. 12*</b>	32	48,2	4

\*Width available upon request, please consult igus® for delivery time

Drilling pattern for width index: **080.10. - 080.20.** center bores only / **080.30. - 080.40.** all bores (see figure above)

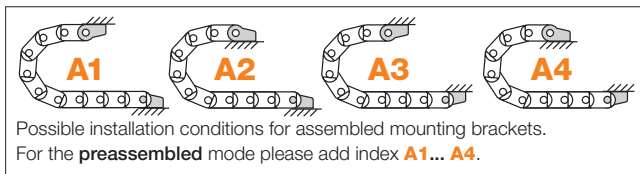

**Part No. structure**

**080.10. 12 PZ A1** A... must be indicated on preassembled configurations  
 With strain relief tiewrap plates  
**Full set**  
 Mounting bracket for selected width index



## Series 08 | One-piece, non snap-open e-chain®

e-chain* non snap-open	<i>Bi</i> [mm]	<i>Ba</i> [mm]	<i>R</i> Bending radii [mm]	Weight [kg/m]
08. 10 . <i>R</i> .0	10	18,2	025   028   038   048	≈ 0,21
08. 13 . <i>R</i> .0	13	21,2	025*   028   038   048*	≈ 0,23
08. 16 . <i>R</i> .0	16	24,2	025*   028   038   048	≈ 0,24
08. 20 . <i>R</i> .0	20	28,2	025   028   038   048	≈ 0,25
08. 30 . <i>R</i> .0	30	38,2	025*   028   038   048	≈ 0,28
08. 40 . <i>R</i> .0	40	48,2	025*   028   038   048	≈ 0,31
08. 50 . <i>R</i> .0	50	58,2	025*   028   038   048	≈ 0,37

\*Radius available upon request, please consult igus® for delivery time

Supplement Part No. with required radius (*R*) Example: 08.50.038.0

## Dimensions

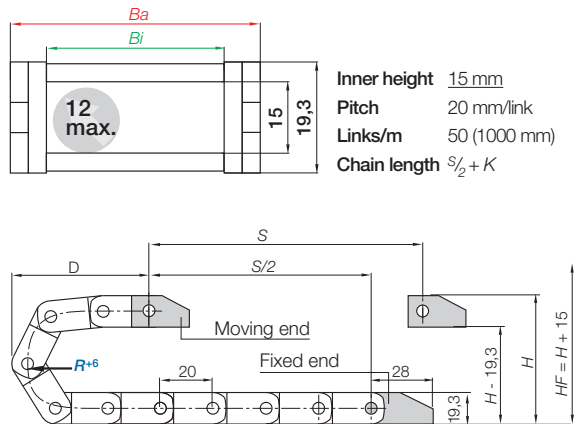
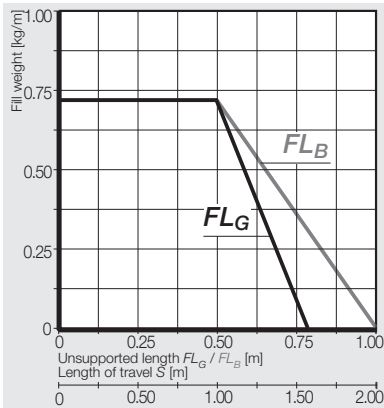

<i>R</i>	025*	028	038	048
<i>H</i>	69	75	95	115
<i>D</i>	65	68	78	88
<i>K</i>	120	130	160	195

The required clearance height:  $H_f = H + 15$  mm (with 0,3 kg/m fill weight)

\*Radius 025 only for Part.No. 08.10. and 08.20.

Mounting brackets, polymer one-piece | locking | More features ► [www.igus.eu/eu/08](http://www.igus.eu/eu/08)

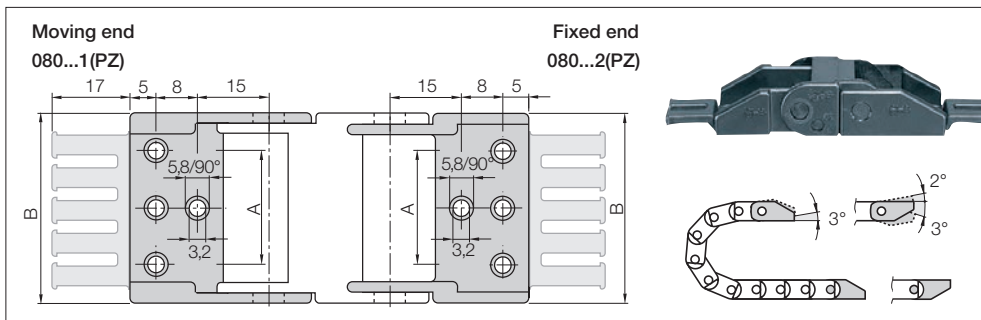

Width Index	Part No. full set with tiewrap plates	Part No. full set without tiewrap plates	Dim A [mm]	Dim B [mm]	Number of teeth
.10. ►	080.10. 12PZ	080.10. 12	-	18,2	1
.13. ►	080.13. 12PZ*	080.13. 12	-	21,2	-
.16. ►	080.16. 12PZ	080.16. 12	-	24,2	2
.20. ►	080.20. 12PZ	080.20. 12	-	28,2	2
.30. ►	080.30. 12PZ	080.30. 12	22	38,2	3
.40. ►	080.40. 12PZ	080.40. 12	32	48,2	4
.50. ►	080.50. 12PZ	080.50. 12	42	58,2	5

\*Available upon request, please consult igus® for delivery time

Drilling pattern for width index: 080.10. - 080.20. center bores only / 080.30. - 080.50. all bores (see figure above)

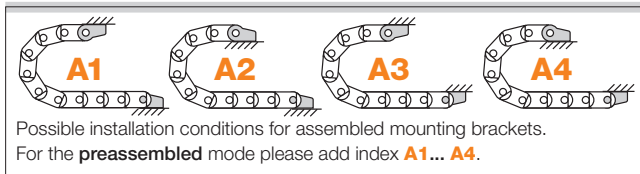

**Part No. structure**  
080.50. 12 PZ **A1**

A...must be indicated on preassembled configurations

With strain relief tiewrap plates

**Full set**

Mounting bracket for selected width index

**Interior separation**

**Slotted separator for e-chains\***

unassembled **B09.2**  
assembled **B09.2.1**

Dimensions: 1,4, 7

**Slotted separator B09.2**  
is used when vertical and horizontal separation is required. Due to its slot, it allows basic vertical/horizontal shelving arrangements.

**Full-width shelf e-chains\*/e-tubes**

unassembled **110.X**  
assembled **111.X**

Dimensions: x, 2

**Full-width shelf 110.X**  
this option makes sense in applications with many thin cables with similar diameters. For a consequent subdivision.

**Full-width shelves**

Width X [mm]	unassembled	assembled	Width X [mm]	unassembled	assembled	Width X [mm]	unassembled	assembled
010	110.10	111.10	020	110.20	111.20	050	110.50	111.50
013	110.13	111.13	030	110.30	111.30			
016	110.16	111.16	040	110.40	111.40			



## Series B09 | Two-piece link design, snap-open along outer radius

Snap-open along outer radius	<i>Bi</i> [mm]	<i>Ba</i> [mm]	<i>R</i> Bending radii [mm]	Weight [kg/m]
B09. 16 . <i>R</i> .0	16	24,2	028   038   048	≈ 0,24
B09. 20 . <i>R</i> .0	20	28,2	028   038   048	≈ 0,25
B09. 30 . <i>R</i> .0	30	38,2	028   038   048	≈ 0,28
B09. 40 . <i>R</i> .0	40	48,2	028   038   048	≈ 0,31

Supplement Part No. with required radius (*R*) Example: B09.40.038.0

## Dimensions

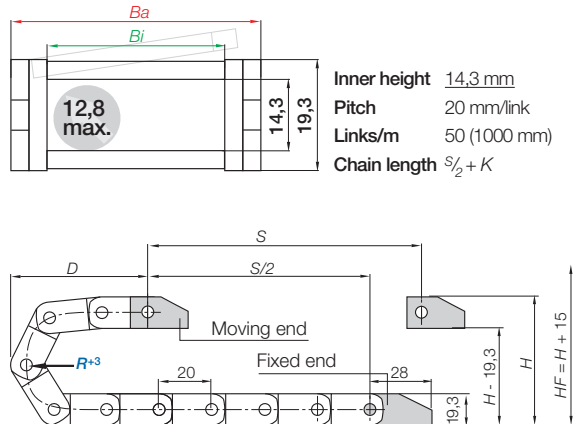
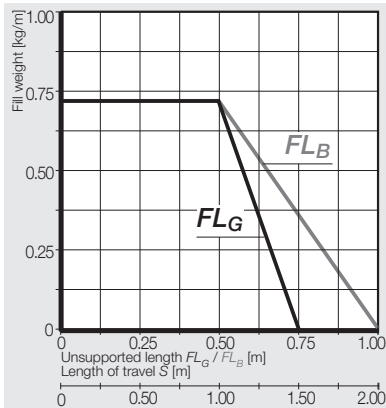

<i>R</i>	028	038	048
<i>H</i>	75	95	115
<i>D</i>	68	78	88
<i>K</i>	130	160	195

The required clearance height:  $H_F = H + 15$  mm (with 0,3 kg/m fill weight)

Mounting brackets, polymer one-piece | locking | More features ► [www.igus.eu/eu/B09](http://www.igus.eu/eu/B09)

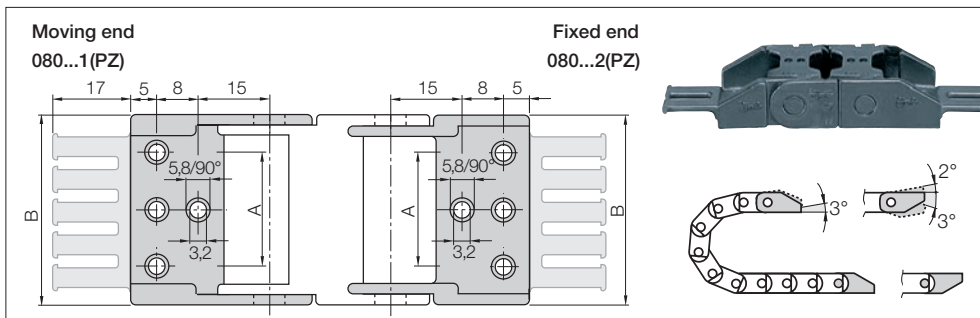

Width Index	Part No. full set with tiewrap plates	Part No. full set without tiewrap plates	Dim A [mm]	Dim B [mm]	Number of teeth
.16. ►	<b>080.16. 12PZ</b>	<b>080.16. 12</b>	–	24,2	2
.20. ►	<b>080.20. 12PZ</b>	<b>080.20. 12</b>	–	28,2	2
.30. ►	<b>080.30. 12PZ</b>	<b>080.30. 12</b>	22	38,2	3
.40. ►	<b>080.40. 12PZ</b>	<b>080.40. 12</b>	32	48,2	4

Drilling pattern for width index: **080.16. - 080.20.** center bores only / **080.30. - 080.40.** all bores (see figure above)

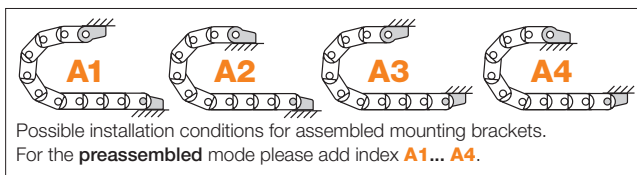

**Part No. structure**

**080.40. 12 PZ A1** A... must be indicated on preassembled configurations  
 With strain relief tiewrap plates  
**Full set**  
 Mounting bracket for selected width index

**Interior separation**

**Slotted separator for e-chains®**  
 unassembled **B09.2**  
 assembled **B09.2.1**

**Slotted separator B09.2**

is used when vertical and horizontal separation is required. Due to its slot, it allows basic vertical/horizontal shelving arrangements.

**Full-width shelf e-chains®/e-tubes**  
 unassembled **110.X**  
 assembled **111.X**

**Full-width shelf 110.X**

this option makes sense in applications with many thin cables with similar diameters. For a consequent subdivision.

**Full-width shelves**

Width X [mm]	unassembled	assembled	Width X [mm]	unassembled	assembled	Width X [mm]	unassembled	assembled
010	<b>110.10</b>	<b>111.10</b>	020	<b>110.20</b>	<b>111.20</b>	050	<b>110.50</b>	<b>111.50</b>
013	<b>110.13</b>	<b>111.13</b>	030	<b>110.30</b>	<b>111.30</b>			
016	<b>110.16</b>	<b>111.16</b>	040	<b>110.40</b>	<b>111.40</b>			

Universal:  
Mounting bracket with  
strain relief option

Space-efficient:  
Smallest inner heights  
and bending radii

Smooth:  
Dirt-repellent exterior

Quiet:  
Small pitch for  
smooth running

Variations:  
Available as two-piece  
design, snap-open  
along inner radius  
(Series 14/F17)

Variations:  
Available as two-piece  
design, snap-open  
along outer radius  
(Series B15/B17)

Variations:  
Available as one-  
piece design, snap-  
open along inner radius  
with film-hinge  
(Series 074/094)

Special version:  
Available as one-piece  
design, non snap-open  
(Series 10/11.031/  
11.080/11.1/11.)

## E2 mini - small and medium sizes

**E2 mini** are small one-piece or two-piece e-chains®, recommended for high dynamic applications. igus® also offers a host of accessories and fixation options. "Upgrades" to openable versions are available for many types; they are interchangeable and can also serve as replacements.

- Small pitch for smooth running
- One- and two-piece e-chains® available
- Smallest inner heights and bending radii
- Very lightweight, easy to assemble and cost-effective

### Typical industries and applications

- Construction machinery
- Handlings
- Furniture
- Packaging machines
- Textile machines
- Vehicle construction
- Woodworking machines
- Glass machines
- Automation
- General machinery

Clean room Class 1 (ISO class 3) for Series 10 and 14, tested by the Dryden Engineering Company, California



UL94-V2 classification - for Series 14 and F17 (UL94-V0 upon request)



Electrically conductive  
ESD/ATEX versions upon request



# E2 mini | Selection Table

Series	Inner height <i>hi</i> [mm]	Inner width <i>Bi</i> [mm]	Outer width <i>Ba</i> [mm]	Outer height <i>ha</i> [mm]	Bending radius <i>R</i> [mm]	Unsupported max. length [m]	Page
--------	--------------------------------	-------------------------------	-------------------------------	--------------------------------	---------------------------------	--------------------------------	------



**E2 mini - One-piece e-chains®**  
One-piece, non snap-open

<b>10</b>	18	15 - 100	26 - 113	23	028 - 180	1,20	<b>224</b>
<b>11.031</b>	23	31	41,2	28	045 - 070	≈1,35	<b>226</b>
<b>11.080</b>	28	80	93	33,4	038	1,50	<b>228</b>
<b>11.1/11.2</b>	41	15 - 25	25,5 - 35,5	46	040 - 100	≈1,35	<b>230</b>



**E2 mini - One-piece e-chains®**  
Snap-open along inner radius with film-hinge

<b>14</b>	20	15 - 50	26 - 61	25	028 - 125	0,65	<b>232</b>
<b>F17</b>	32	15	26	39	048	1,20	<b>238</b>

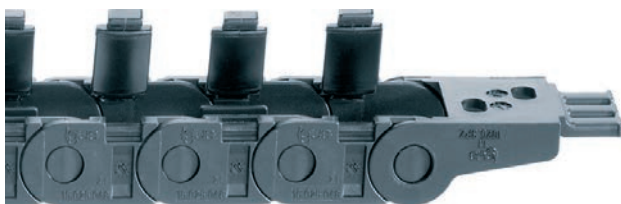

**E2 mini - Two-piece e-chains®**  
Snap-open along outer radius

<b>B15</b>	17	15 - 100	26 - 113	23	038 - 180	1,20	<b>234</b>
<b>B17</b>	32	15 - 100	25,5 - 113	39	048 - 125	1,00	<b>236</b>



**E2 mini - Two-piece e-chains®**  
Snap-open along inner radius

<b>B15i</b>	17	15 - 100	26 - 113	23	038 - 180	1,20	<b>234</b>
<b>B17i</b>	32	38	48,5	39	048 - 125	1,00	<b>236</b>

## Technical Data



Gliding speed / acceleration (maximum) max. 3 [m/s] / max. 10 [m/s<sup>2</sup>]

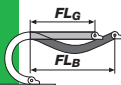

Speed / acceleration  $FL_G$  max. max. 20 [m/s] / max. 200 [m/s<sup>2</sup>]

Speed / acceleration  $FL_B$  max. max. 3 [m/s] / max. 6 [m/s<sup>2</sup>]



Material - permitted temperature °C, igumid G -40° up to +120° C

Material - permitted temperature °C, igumid NB (only Series 14, F17) -40° up to +80° C



Flammability class: igumid G = VDE 0304 IIC UL94-HB / igumid NB = VDE 0304 IIC UL94-V2

■  $FL_G$  = with straight upper run ■  $FL_B$  = with permitted sag









## Installation methods overview, maximum travels

e-chain® Series	Unsupported application	Vertical hanging	Vertical standing	Side mounted unsupported	Rotary application	Zig-zag application
10	≤ 1,20 m	upon request	upon request	upon request	with rework	upon request
11.031	≤ 1,35 m	upon request	upon request	upon request	—	upon request
11.080	≤ 1,50 m	upon request	upon request	upon request	—	upon request
11.1/11.2	≤ 1,35 m	upon request	upon request	upon request	—	upon request
14	≤ 0,65 m	upon request	upon request	upon request	with rework	upon request
B15i / B15	≤ 1,20 m	upon request	upon request	upon request	with rework	upon request
B17i / B17	≤ 1,00 m	upon request	upon request	upon request	with rework	upon request
F17	≤ 1,20 m	upon request	upon request	upon request	with rework	upon request



# E2 mini | Order keys and Options

## Options with order keys based on Series B15

 <b>Standard</b>	<i>NC-Version - (no camber) without pretension</i>	<i>Reverse bending radius for circular movements</i>	<i>Unsupported lengths +25% possible</i>	<i>ESD / ATEX classified e-chains®</i> 
Part No. <b>Standard e-chains®</b> 	Part No. <b>NC-Version e-chains®</b> NC 	Part No. <b>RBR e-chains®</b> 	Part No. <b>XXL-Material* e-chains®</b> 	Part No. <b>ESD-Material e-chains®</b> 
 <b>B15.025.R.0</b>	<b>B15.025.R.0.NC</b>	<b>B15.025.R1/R2.0</b>	<b>B15.025.R.0.XXL</b>	<b>B15.025.R.0.ESD</b>
 <b>Delivery from stock</b>	<b>Delivery time: upon request</b>	<b>Delivery time: upon request</b>	<b>Delivery time: upon request</b>	<b>Delivery time: upon request</b>

## Order example | Order key and color options based on Series B15

 **Order example for complete e-chain® (1,0 m), color black, with mounting brackets and interior separation:**

<b>e-chain® (1,0 m)</b>	Please indicate e-chain® length or number of links: 1,0 m or 33 links	<b>B15.025.038.0</b>
<b>+ Mounting brackets</b>	1 set (+ tiwrap plates)	<b>1025.34PZ</b>
<b>+ Interior separation</b>	with 2 separators assembled every 2 <sup>nd</sup> link	<b>2 x 154</b>
<b>Order text: 1,0 m B15.025.038.0 + 1025.34PZ + 2 x 154</b>		







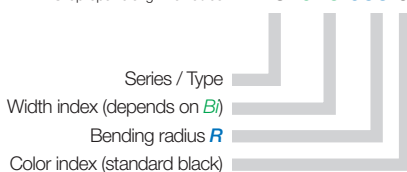



### Order key

Snap-open along outer radius  
Snap-open along inner radius

**B15.025.038.0**  
**B15i.025.038.0**



### General igus® color options for e-chains® and e-tubes

Color	Order index	Color	Order index
 <b>Black</b> Standard, from stock!	<b>.0</b>	 <b>White</b> special color	<b>.1</b>
 <b>Slate grey</b> only ESD material	<b>.ESD</b>	 <b>Gray white</b> special color	<b>.1S</b>
 <b>Gray brown</b> only HT material	<b>.HT</b>	 <b>Orange</b> special color	<b>.2</b>
 <b>Gray</b> special color only e-chains®	<b>.3</b>	 <b>Yellow</b> special color	<b>.4</b>
 <b>Dusty grey</b> special color only e-tubes	<b>.31</b>	 <b>Light grey</b> special color	<b>.14</b>

**Black e-chains® available from stock!**

**Delivery time for special colors: upon request**

**B15.025.038.0** = Snap-open along outer radius, inner width *Bi* 25 mm, radius *R* 38 mm, color black

**B15i.025.038.0** = Snap-open along inner radius, inner width *Bi* 25 mm, radius *R* 38 mm, color black



## Series 10 | One-piece, non snap-open e-chain®

e-chain* non snap-open	<i>Bi</i> [mm]	<i>Ba</i> [mm]	<i>R</i> Bending radii [mm]	Weight [kg/m]
10. 015 .R.0	15	26	028   038   048   075   100   110   125   145   180	≈ 0,35
10. 025 .R.0	25	36	028   038   048   075   100   110   125   145   180	≈ 0,40
10. 038 .R.0	38	49	028   038   048   075   100   110   125   145   180	≈ 0,46
10. 050 .R.0	50	61	028   038   048   075   100   110   125   145   180	≈ 0,52
10. 5 .R.0	63	76	028   038   048   075   100   110   125   145   180	≈ 0,63
10. 6 .R.0	80	94	028   038   048   075   100   110   125   145   180	≈ 0,70
10. 7 .R.0	100	113	028   038   048   075   100   110   125   145   180	≈ 0,76

Before using this Series on long travels please consult igus®.

Supplement Part No. with required radius (*R*) Example: 10.025.038.0

## Dimensions

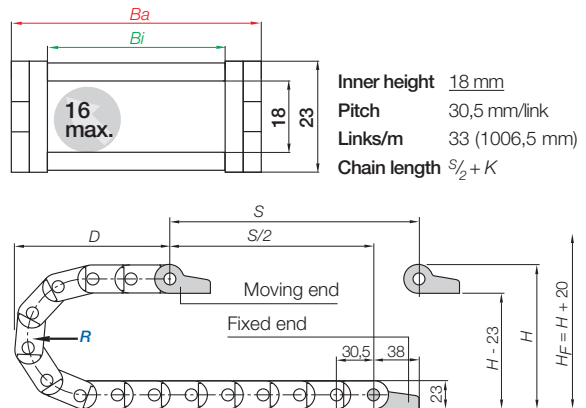
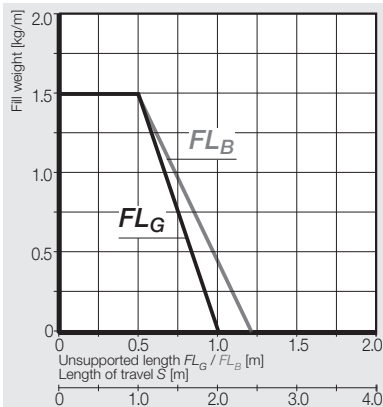

<i>R</i>	028	038	048	075	100	110	125	145	180
<i>H</i>	79	99	119	173	223	243	273	313	383
<i>D</i>	85	95	105	132	157	167	182	202	237
<i>K</i>	150	185	215	300	380	410	455	520	630

The required clearance height:  $H_F = H + 20$  mm (with 0,5 kg/m fill weight)

Mounting brackets, polymer one-piece | pivoting | locking

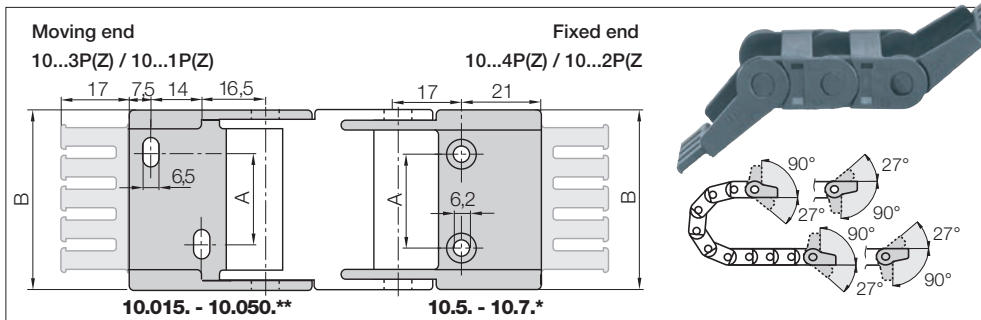

Width Index		Part No. full set pivoting:		Part No. full set locking:		Dim A [mm]	Dim B [mm]	Number of teeth
		with tiewrap plates	without tiewrap plates	with tiewrap plates	without tiewrap plates			
015.	▶	1015.34PZ	1015.34P	1015.12PZ	1015.12P	-	25,5	2
025.	▶	1025.34PZ	1025.34P	1025.12PZ	1025.12P	10	35,5	3
038.	▶	1038.34PZ	1038.34P	1038.12PZ	1038.12P	23	48,5	4
050.	▶	1050.34PZ	1050.34P	1050.12PZ	1050.12P	35	60,5	5
5.	▶	105. 34PZ	105. 34P	105. 12PZ	105. 12P	48	75	6
6.	▶	106. 34PZ	106. 34P	106. 12PZ	106. 12P	65	92	8
7.	▶	107. 34PZ	107. 34P	107. 12PZ	107. 12P	85	112	10

\*\* Drilling pattern for width index: 15.015. - 15.050. see drawing left. Each valid for Moving end and Fixed end

\* Drilling pattern for width index: 15.5 - 15.7. see drawing right. Each valid for Moving end and Fixed end

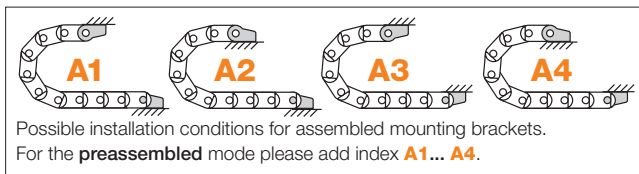

Part No. structure

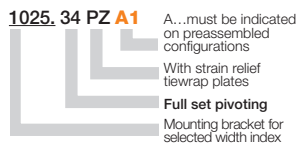

Interior separation

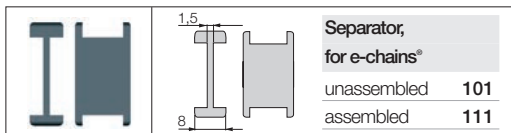

Separator 101

For a simple vertical subdivision on e-chains®. Separators can be arranged anywhere in the e-chain® cross section.

Interior separation for Series 10.015.R.0 not possible!

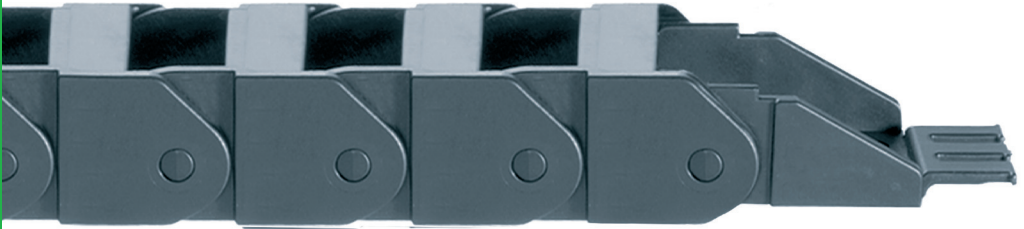

## Series 11.031 | One-piece, non snap-open e-chain®

e-chain* non snap-open	<i>Bi</i> [mm]	<i>Ba</i> [mm]	<i>R</i> Bending radii [mm]	Weight [kg/m]
11. 031 .R.0	31	41,2	045   070	≈ 0,43

Supplement Part No. with required radius (*R*) Example: 11.031.045.0

## Dimensions

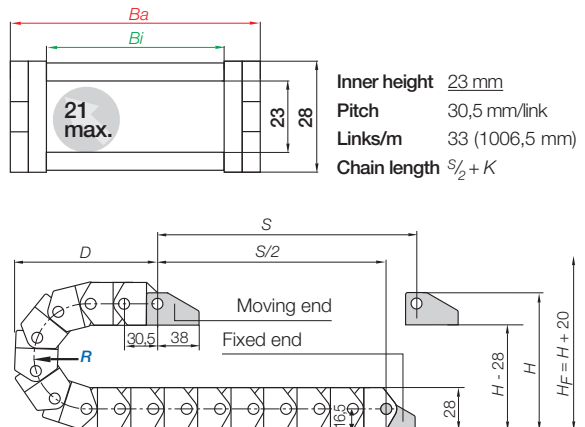
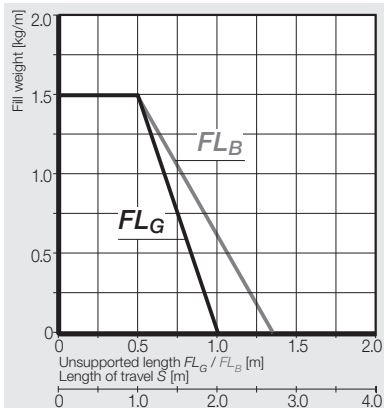

<i>R</i>	045	070
<i>H</i>	123	173
<i>D</i>	107	132
<i>K</i>	205	285

The required clearance height:  $H_F = H + 20$  mm (with 0,5 kg/m fill weight)

Mounting brackets, polymer one-piece | pivoting

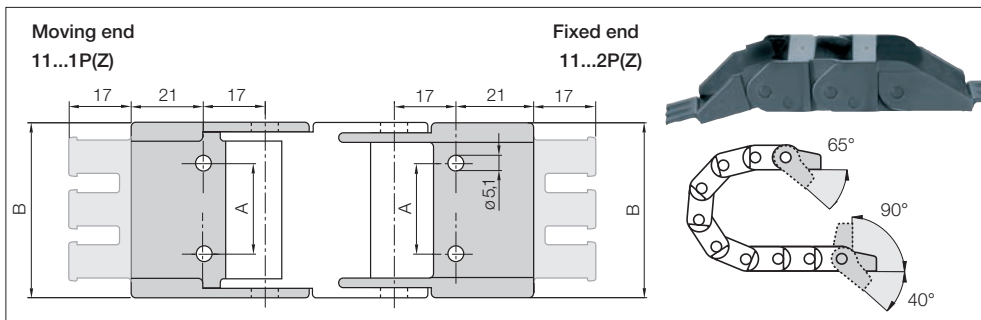

Width Index	 Part No. full set <b>with</b> tiewrap plates	Part No. full set <b>without</b> tiewrap plates	Dim A [mm]	Dim B [mm]	Number of teeth
031. ▶	<b>11.031.12PZ</b>	<b>11.031.12P</b>	16	42	3

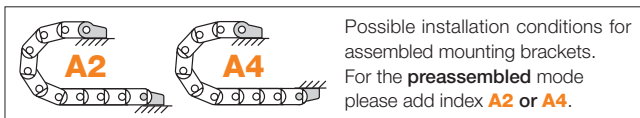

Possible installation conditions for assembled mounting brackets. For the **preassembled** mode please add index **A2** or **A4**.

Part No. structure  
**11.031. 12 PZ A2** A...must be indicated on preassembled configurations  
 With strain relief tiewrap plates  
**Full set pivoting**  
 Mounting bracket for selected width index

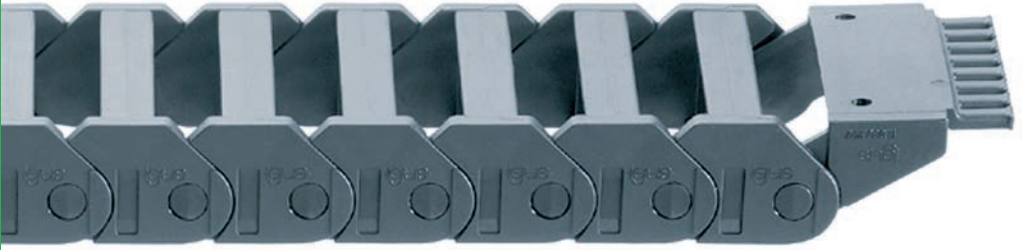

## Series 11.080 | Non snap-open e-chain® with moulded-in vertical separation

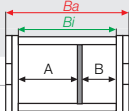
e-chain* non snap-open	<i>Bi</i> [mm]	<i>Ba</i> [mm]	<i>R</i> Bending radii [mm]		Dim. A [mm]	Dim. B [mm]	Weight [kg/m]
<b>11.080 .R.0</b>	<b>80</b>	<b>93</b>	<b>038</b>		<b>46</b>	<b>32</b>	≈ 0,73

Supplement Part No. with required radius (*R*) Example: **11.080.038.0**

## Dimensions

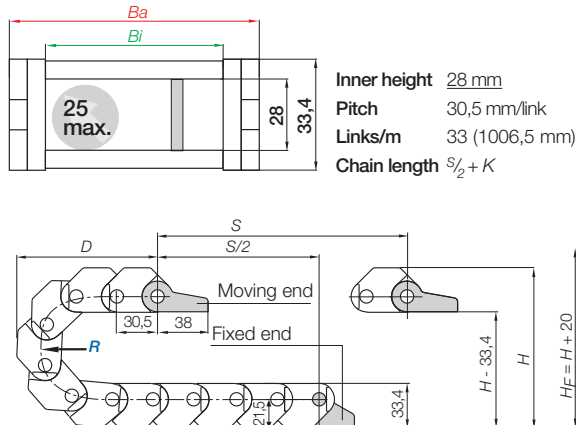
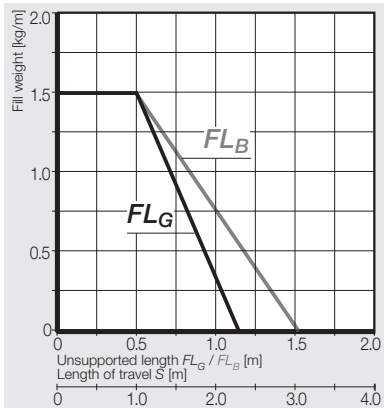

<b><i>R</i></b>	<b>038</b>
<b><i>H</i></b>	119
<b><i>D</i></b>	105
<b><i>K</i></b>	185

The required clearance height:  $H_F = H + 20$  mm (with 0,5 kg/m fill weight)

Mounting brackets, polymer one-piece | pivoting

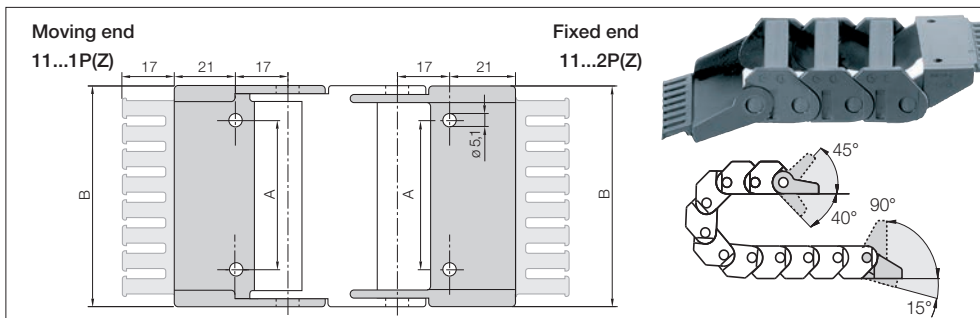

Width Index	 Part No. full set with tie-wrap plates	Part No. full set without tie-wrap plates	Dim A [mm]	Dim B [mm]	Number of teeth
080. ▶	11.080.12PZ	11.080.12P	65	93	8

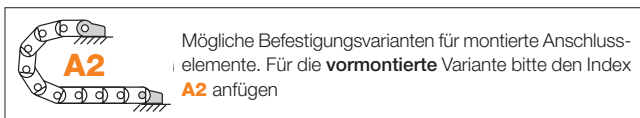

Part No. structure

**11.080. 12 PZ A2** A...must be indicated on preassembled configurations

With strain relief tie-wrap plates

**Full set pivoting** Mounting bracket for selected width index



Series 11.1·11.2 | One-piece, non snap-open e-chain®

e-chain* non snap-open	Bi [mm]	Ba [mm]	R Bending radii [mm]	Weight [kg/m]
11. 1 .R.0	15	25,5	040   063   075   100	≈ 0,50
11. 2 .R.0	25	35,5	040   063   075   100	≈ 0,53

Supplement Part No. with required radius (R) Example: 11.1.040.0

Dimensions

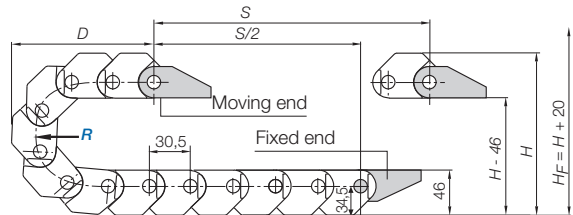
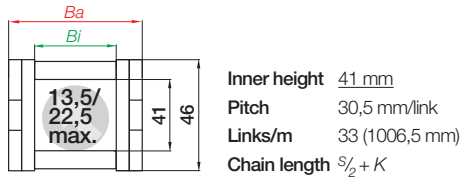
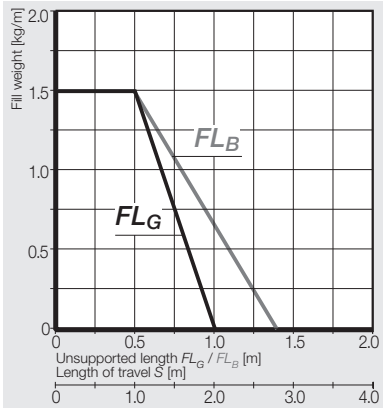



R	040	063	075	100
H	149	195	219	269
D	120	143	155	180
K	190	260	300	380

The required clearance height:  $H_F = H + 20$  mm (with 0,5 kg/m fill weight)

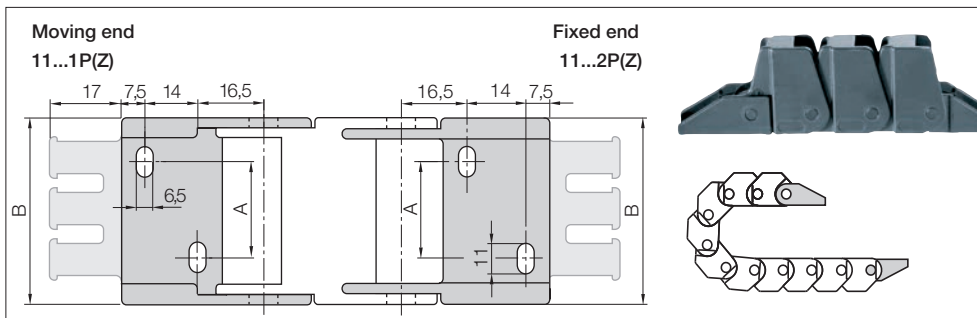

Mounting brackets, polymer one-piece | locking



Width Index	 Part No. full set <b>with</b> tiewrap plates	Part No. full set <b>without</b> tiewrap plates	Dim A [mm]	Dim B [mm]	Number of teeth
1. ▶	<b>101.12PZ</b>	<b>101.12P</b>	–	26	2
2. ▶	<b>102.12PZ</b>	<b>102.12P</b>	10	36	3

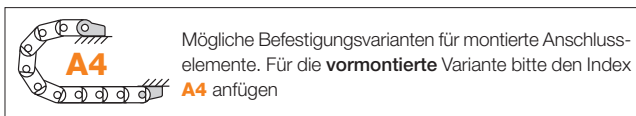

Part No. structure

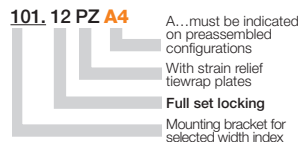

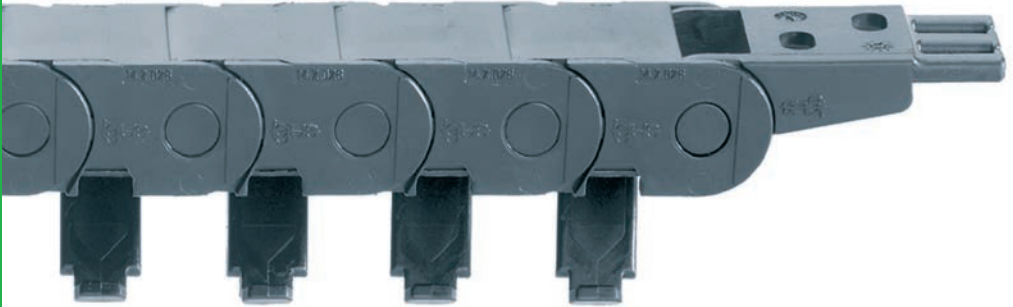

## Series 14 | One-piece, snap-open along inner radius with film-hinge

Snap-open along inner radius	<i>Bi</i> [mm]	<i>Ba</i> [mm]	<i>R</i> Bending radii [mm]	Weight [kg/m]
14. 1 .R.0	15	26	028   038   048   075   100   125	≈ 0,31
14. 2 .R.0	25	36	028   038   048   075   100   125	≈ 0,32
14. 3 .R.0	38	49	028   038   048   075   100   125	≈ 0,40
14. 4 .R.0	50	61	028   038   048   075   100   125	≈ 0,41

Supplement Part No. with required radius (*R*) Example: 14.2.038.0

## Dimensions

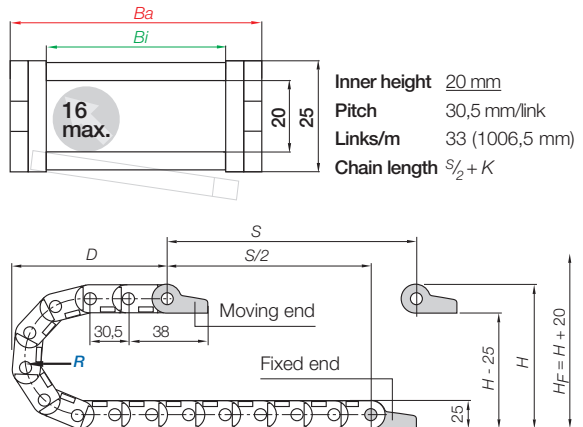
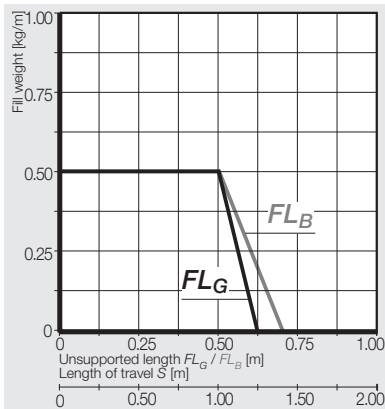

<i>R</i>	028	038	048	075	100	125
<i>H</i>	81	101	121	175	225	275
<i>D</i>	86	96	106	133	158	183
<i>K</i>	150	185	215	300	380	455

The required clearance height:  $H_F = H + 20$  mm (with 0,5 kg/m fill weight)

Mounting brackets, polymer one-piece | locking | More features ► [www.igus.eu/eu/14](http://www.igus.eu/eu/14)

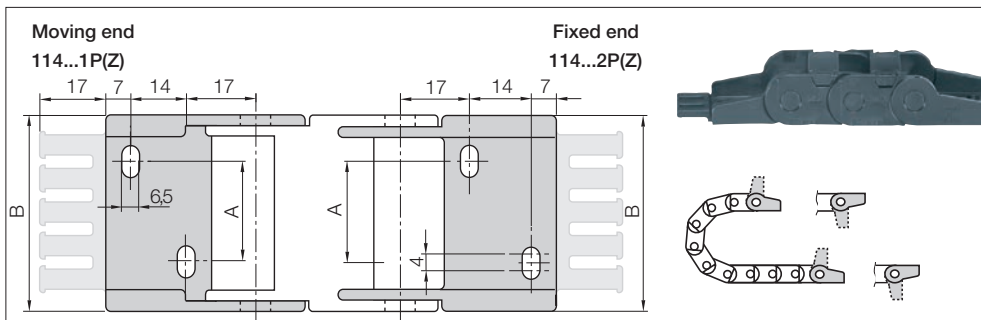

Width Index	 Part No. full set with tie-wrap plates	Part No. full set without tie-wrap plates	Dim A [mm]	Dim B [mm]	Number of teeth
1. ►	<b>114.1.12PZ</b>	<b>114.1.12P</b>	–	26,3	2
2. ►	<b>114.2.12PZ</b>	<b>114.2.12P</b>	10	36,3	3
3. ►	<b>114.3.12PZ</b>	<b>114.3.12P</b>	23	49,3	4
4. ►	<b>114.4.12PZ</b>	<b>114.4.12P</b>	35	61,3	5

Material mounting bracket - igumid G, temperature: -40° up to +120° C, VDE 0304 IIC UL94-HB

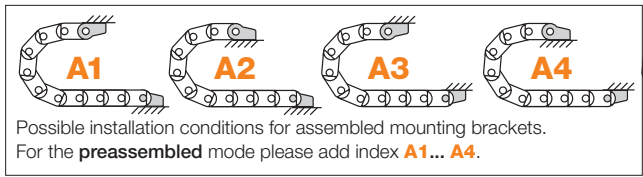

**Part No. structure**  
**114.2. 12 PZ A1** A...must be indicated on preassembled configurations  
 With strain relief tie-wrap plates  
**Full set pivoting**  
 Mounting bracket for selected width index



## Series B15i snap-open along inner radius | Series B15 along outer radius - Standard

Snap-open along inner radius	Snap-open along outer radius		<i>Bi</i> [mm]	<i>Ba</i> [mm]	<i>R</i> Bending radii [mm]										B15i [kg/m]	B15 [kg/m]
B15i.015 .R.0	B15.015 .R.0		15	26	038	048	075	100	110	125	145	180	≈0,35	≈0,35		
B15i.025 .R.0	B15.025 .R.0		25	36	038	048	075	100	110	125	145	180	≈0,40	≈0,40		
B15i.038 .R.0	B15.038 .R.0		38	49	038	048	075	100	110	125	145	180	≈0,46	≈0,46		
B15i.050 .R.0	B15.050 .R.0		50	61	038	048	075	100	110	125	145	180	≈0,52	≈0,52		
B15i.5 .R.0	B15.5 .R.0		63	76	038	048	075	100	110	125	145	180	≈0,63	≈0,63		
B15i.6 .R.0	B15.6 .R.0		80	94	038	048	075	100	110	125	145	180	≈0,70	≈0,70		
B15i.7 .R.0	B15.7 .R.0		100	113	038	048	075	100	110	125	145	180	≈0,76	≈0,76		

Before using this Series on long travels please consult igus®.

Supplement Part No. with required radius (*R*) Example: **B15.025.038.0**

## Dimensions

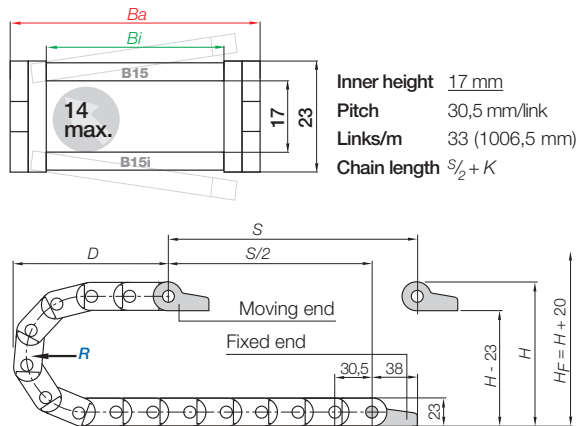
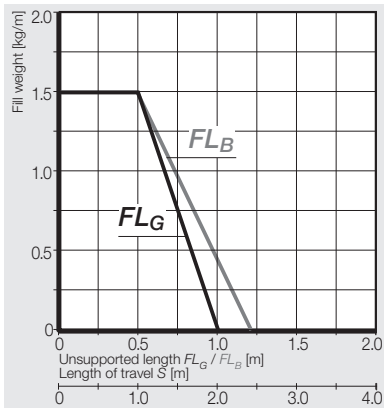

<i>R</i>	038	048	075	100	110	125	145	180
<i>H</i>	99	119	173	223	243	273	313	383
<i>D</i>	95	105	132	157	167	182	202	237
<i>K</i>	185	215	300	380	410	455	520	630

The required clearance height:  $H_F = H + 20$  mm (with 0,5 kg/m fill weight)



## Mounting brackets, polymer one-piece | pivoting | locking

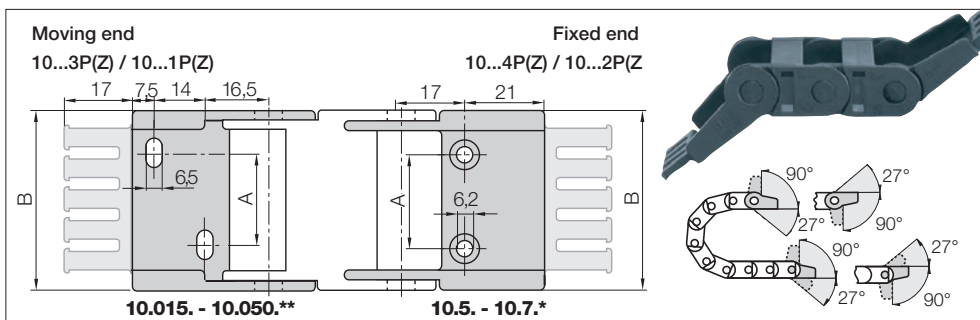

Width Index	Part No. full set <b>pivoting:</b> with tiewrap plates	without tiewrap plates	Part No. full set <b>locking:</b>		Dim A [mm]	Dim B [mm]	Number of teeth
			with tiewrap plates	without tiewrap plates			
015.	1015.34PZ	1015.34P	1015.12PZ	1015.12P	-	25,5	2
025.	1025.34PZ	1025.34P	1025.12PZ	1025.12P	10	35,5	3
038.	1038.34PZ	1038.34P	1038.12PZ	1038.12P	23	48,5	4
050.	1050.34PZ	1050.34P	1050.12PZ	1050.12P	35	60,5	5
5.	105. 34PZ	105. 34P	105. 12PZ	105. 12P	48	75	6
6.	106. 34PZ	106. 34P	106. 12PZ	106. 12P	65	92	8
7.	107. 34PZ	107. 34P	107. 12PZ	107. 12P	85	112	10

\*\* Drilling pattern for width index: 15.015. - 15.050. see drawing left. Each valid for Moving end and Fixed end

\* Drilling pattern for width index: 15.5 - 15.7. see drawing right. Each valid for Moving end and Fixed end

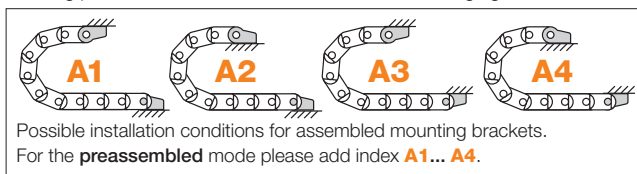

### Part No. structure

**1025. 34 PZ A1**

A...must be indicated on preassembled configurations  
With strain relief tiewrap plates  
**Full set pivoting**  
Mounting bracket for selected width index

## Interior separation

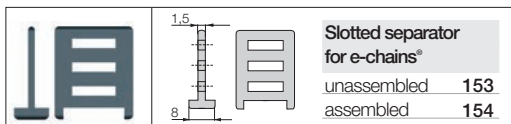

### Slotted separator 153

is used when vertical and horizontal separation is required. Due to its slot, it allows basic vertical/horizontal shelving arrangements.

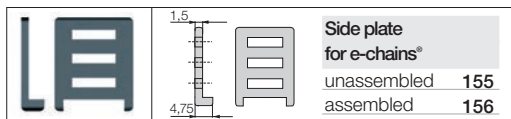

### Side plate 155

Side plate for use with full-width shelf 110.X and slotted separator 153.

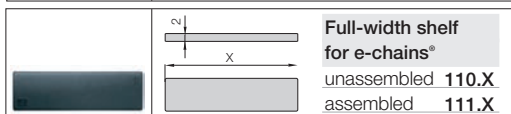

### Full-width shelf 110.X

this option makes sense in applications with many thin cables with similar diameters. For a consequent subdivision. Full-width shelves can be arranged at 3 different heights (in 5 mm increments).

## Full-width shelves

Width X [mm]	unassembled	assembled	Width X [mm]	unassembled	assembled	Width X [mm]	unassembled	assembled
015	110.15	111.15	050	110.50	111.50	100	110.100	111.100
025	110.25	111.25	063	110.63	111.63			
038	110.38	111.38	080	110.80	111.80			

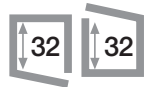

## Series B17i snap-open along inner radius | Series B17 along outer radius - Standard

Snap-open along inner radius	Snap-open along outer radius 	<i>B<sub>i</sub></i> [mm]	<i>B<sub>a</sub></i> [mm]	<i>R</i> Bending radii [mm]					B17i [kg/m]	B17 [kg/m]
B17i.1 . <i>R</i> .0**	B17.1 . <i>R</i> .0	15	25,5	048	063	075	100	125	≈ 0,52	≈ 0,52
B17i.2 . <i>R</i> .0**	B17.2 . <i>R</i> .0	25	35,5	048	063	075	100	125	≈ 0,59	≈ 0,59
B17i.3 . <i>R</i> .0	B17.3 . <i>R</i> .0	38	48,5	048	063	075	100	125	≈ 0,65	≈ 0,65
B17i.4 . <i>R</i> .0	B17.4 . <i>R</i> .0	50	60,5	048	063	075	100*	125*	≈ 0,70	≈ 0,70
B17i.5 . <i>R</i> .0**	B17.5 . <i>R</i> .0	63	76	048*	063	075	100	125	≈ 0,83	≈ 0,83
B17i.6 . <i>R</i> .0**	B17.6 . <i>R</i> .0	80	93	048	063	075	100	125	≈ 0,92	≈ 0,92
B17i.7 . <i>R</i> .0**	B17.7 . <i>R</i> .0	100	113	048*	063	075	100	125	≈ 1,06	≈ 1,06

\*\*Width available upon request, please consult igus\* for delivery time \*Radius available upon request, please consult igus\* for delivery time

Supplement Part No. with required radius (*R*) Example: **B17.2.048.0**

## Dimensions

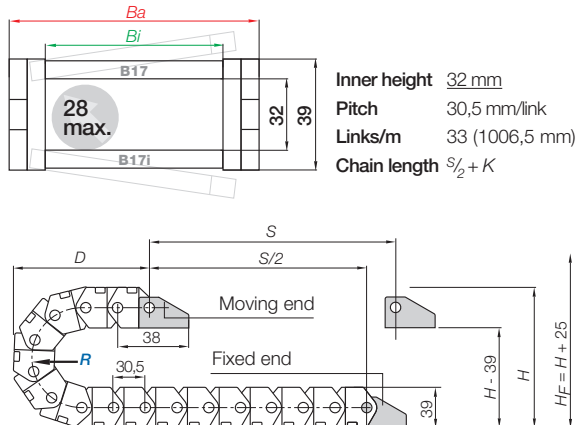
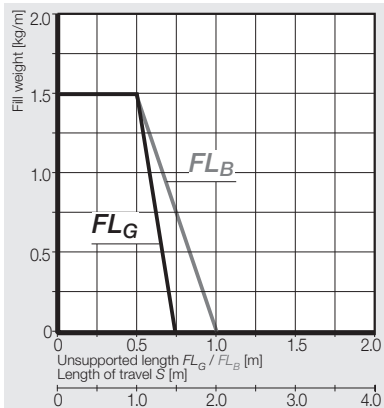

<i>R</i>	048 <sup>1)</sup>	063	075	100 <sup>2)</sup>	125 <sup>2)</sup>
<i>H</i>	135	165	189	239	289
<i>D</i>	113	128	140	165	190
<i>K</i>	215	260	300	380	455

The required clearance height:  $H_c = H + 25$  mm (with 1,5 kg/m fill weight)

<sup>1)</sup> For Series B17i.5/B17.5, B17i.7/B17.7 Radius 048 upon request. <sup>2)</sup> For Series B17i.4/B17.4 Radii 100, 125 upon request. Please consult igus\* for delivery time

Mounting brackets, polymer one-piece | locking

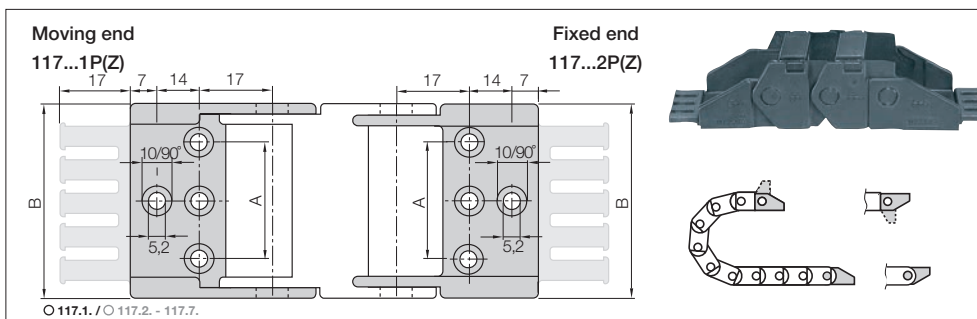

Width Index	Part No. full set with tiewrap plates	Part No. full set without tiewrap plates	Dim A [mm]	Dim B [mm]	Number of teeth
1.	117.1.12PZ	117.1.12P	-	25,5	2
2.	117.2.12PZ	117.2.12P	12	35,5	3
3.	117.3.12PZ	117.3.12P	25	48,5	4
4.	117.4.12PZ	117.4.12P	37	60,5	5
5.	117.5.12PZ	117.5.12P	48	76	6
6.	117.6.12PZ	117.6.12P	65	93	8
7.	117.7.12PZ	117.7.12P	85	113	10

○ Drilling pattern for width index: 117.1. center bores only / ○ 117.2. -117.7. outer bores only (see figure above)

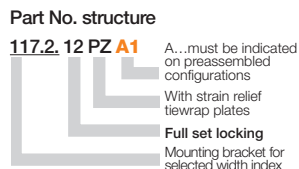
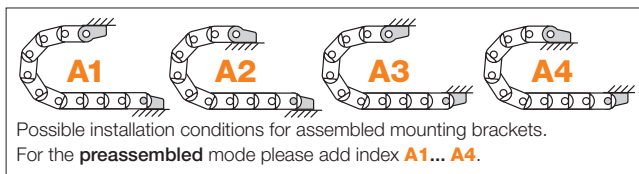

Interior separation | Standard | Further interior separation elements ► [www.igus.eu/eu/B17](http://www.igus.eu/eu/B17)

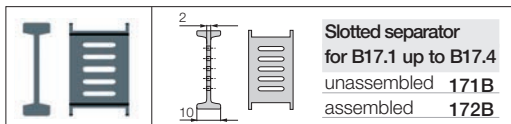

**Slotted separator 171B** (B17.1 up to B17.4) is used when vertical and horizontal separation is required. Due to its slot, it allows basic vertical/horizontal shelving arrangements.

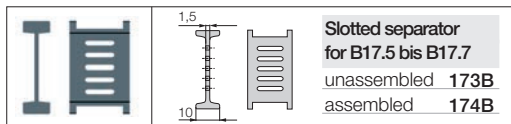

**Slotted separator 173B** (B17.5 up to B17.7) is used when vertical and horizontal separation is required. Due to its slot, it allows basic vertical/horizontal shelving arrangements.

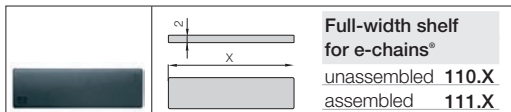

**Full-width shelf 110.X** (for all widths) this option makes sense in applications with many thin cables with similar diameters. For a consequent subdivision. Full-width shelves can be arranged at 5 different heights (in 5 mm increments).

Full-width shelves

Width X [mm]	unassembled	assembled	Width X [mm]	unassembled	assembled	Width X [mm]	unassembled	assembled
015	110.15	111.15	050	110.50	111.50	100	110.100	111.100
025	110.25	111.25	063	110.63	111.63			
038	110.38	111.38	080	110.80	111.80			



## Series F17 | One-piece, snap-open along inner radius with film-hinge

Snap-open along inner radius	<i>Bi</i> [mm]	<i>Ba</i> [mm]	<i>R</i> Bending radii [mm]	Weight [kg/m]
<b>F17.015.R.0</b>	<b>15</b>	<b>26</b>	048   063*   075*   100*   125*	≈ 0,52

\*Radius available upon request, please consult igus\* for delivery time

Supplement Part No. with required radius (*R*) Example: **F17.015.048.0**

## Dimensions

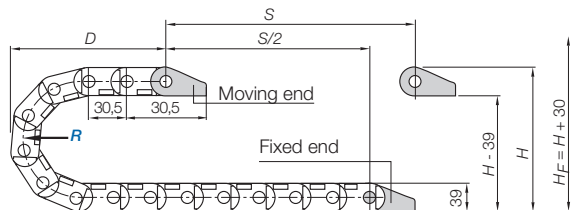
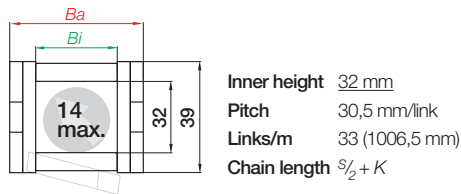
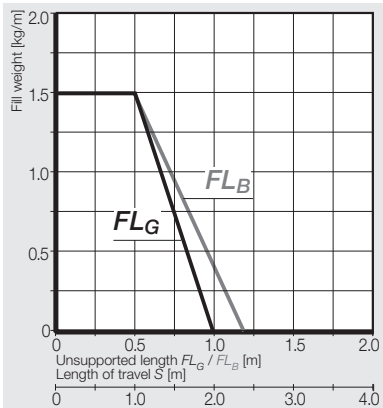

<i>R</i>	048	063*	075*	100*	125*
<i>H</i>	135	165	189	239	289
<i>D</i>	113	128	140	165	190
<i>K</i>	215	260	300	380	455

The required clearance height:  $H_c = H + 30$  mm (with 0,5 kg/m fill weight) \*

\*Radius available upon request, please consult igus\* for delivery time



Mounting brackets, polymer one-piece | locking

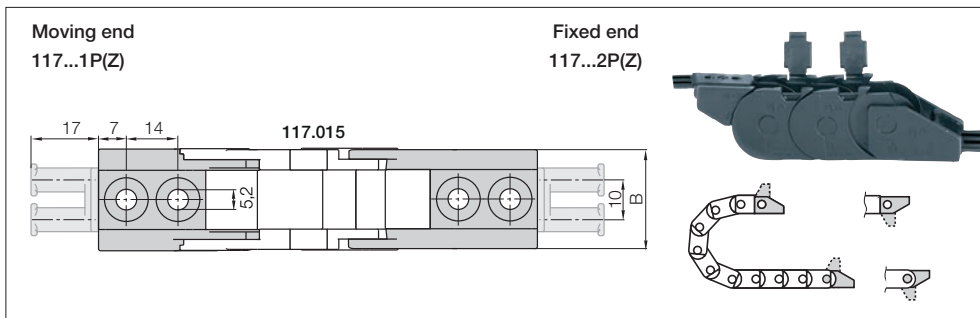

Width Index	Part No. full set with tiewrap plates	Part No. full set without tiewrap plates	Dim A [mm]	Dim B [mm]	Number of teeth
015 ▶	117.015.12PZ	117.015.12P	-	27,7	2

Material mounting bracket - igumid G, temperature: -40° up to +120° C, VDE 0304 IIC UL94-HB

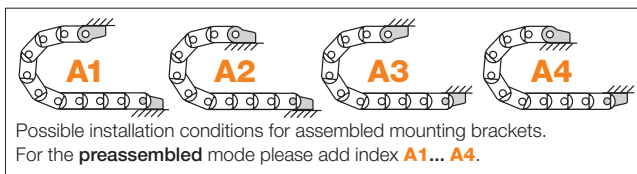

Part No. structure

**117.015.12 PZ A1** A...must be indicated on preassembled configurations

- With strain relief tiewrap plates
- Full set locking**
- Mounting bracket for selected width index

Interior separation

**Slotted separator for e-chains®**

unassembled **R171**  
assembled **R172**

**Slotted separator R171**

is used when vertical and horizontal separation is required. Due to its slot, it allows basic vertical/horizontal shelving arrangements.

**Full-width shelf e-chains®/e-tubes**

unassembled **110.X**  
assembled **111.X**

**Full-width shelf 110.X**

this option makes sense in applications with many thin cables with similar diameters. For a consequent subdivision. Full-width shelves can be arranged at 5 different heights (in 5 mm increments).

Full-width shelves

Width X [mm]	unassembled	assembled
015	110.15	111.15

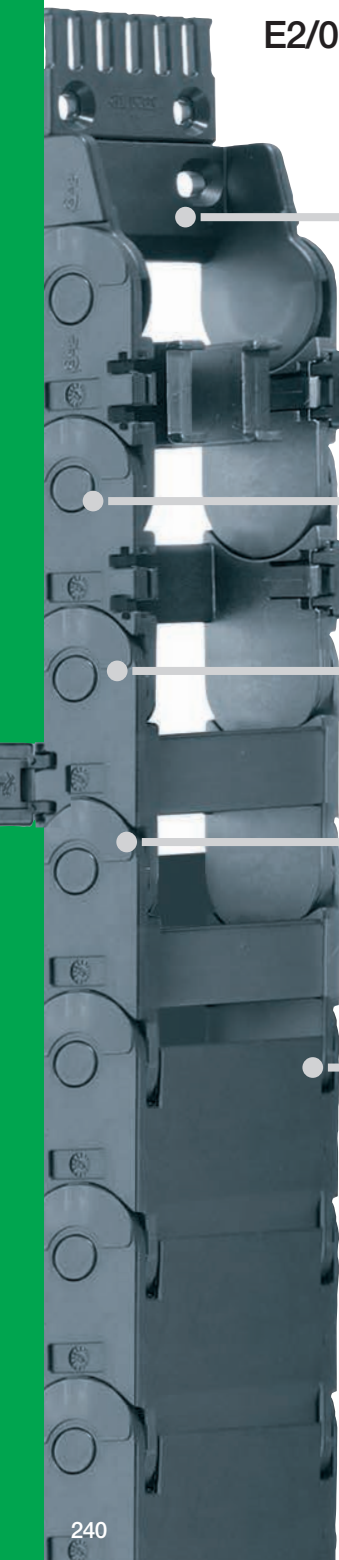

Universal:  
Many mounting options  
with or without strain relief

Easy to assemble:  
Opening system  
from left or right

High stability:  
Large pin "snap fastener"  
with high clamping force

Long lifetime:  
Lateral gliding surfaces

High unsupported  
lengths:  
Due to a double,  
squared stop dog

Variations:  
e-chain® or e-tube,  
openable at the  
inner or outer radius

# E2/000 - with 2-piece link-design for a wide range of applications

**E2/000 - the E2 standard** it is igus® fourth generation in this popular size range. All past experiences went into this Series: easy and versatile assembly combined with ruggedness - high stability paired with quieter motion - long cable life and many fixation options. The design is consistent within all E2/000 variations. It is the standard product for machine builders around the world.

## Typical industries and applications

- Material handling
- Construction machinery
- Woodworking machines
- Glass machines
- Plastic machines
- Long travel applications in many industries
- Semicon
- Theatre, entertainment and amusement parcs
- Vehicles
- General machinery



IPA Qualification Certificate Clean room ISO Class 3 (DIN 14644-1), at  $v = 2 \text{ m/s}$ , with standard material igumid G - Series 2500.05.055.0



Electrically conductive ESD/ATEX versions several Series available from stock



46 dB(A) tested in igus® lab,  $v = 1,0 \text{ m/s}$  unsupported, e.g. Series 2600.05.075.0



UL94-V0 classification upon request





New snap-open mechanism, choice of snap-open on left or right

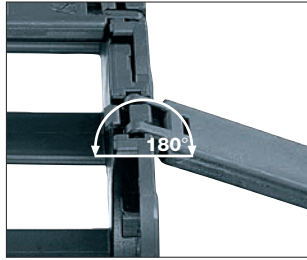

Hinged crossbar can be swiveled by more than 180° on both sides

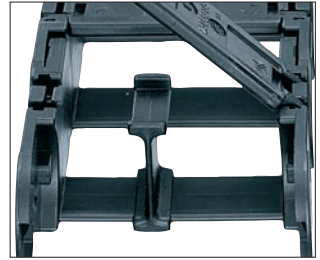

Secure fit of separators and interior separation even when e-chain® is open



Half e-tube - Fully enclosed in outer radius, choice of snap-open on left or right



Fast closing by thumb - secure fit without additional locking devices

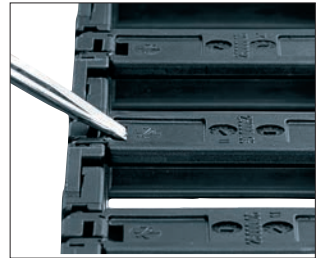

Rapid opening with a screwdriver or the e-chain® opener



Open E2/000 in a flash with the e-chain® opener ► [www.igus.eu/eu/savetime](http://www.igus.eu/eu/savetime)

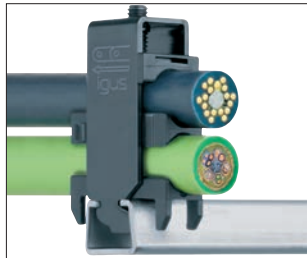

Strain relief e.g. clamps, tiwrap plates, nugs and plug-in clips ► **from page 630**



Extender crossbars - Enormous increase of the interior



Aluminium "SuperTrough" - The igus® standard guide trough ► **from page 664**



rol e-chain® E2/000 - Rolling instead of gliding. Reduce driving force



Support tray tool kit. For support of the lower run ► **from page 714**

# E2/000 | Selection Table

Series	Inner height <i>hi</i> [mm]	Inner width <i>Bi</i> [mm]	Outer width <i>Ba</i> [mm]	Outer height <i>ha</i> [mm]	Bending radius <i>R</i> [mm]	Unsupported max. length [m]	Page
--------	--------------------------------	-------------------------------	-------------------------------	--------------------------------	---------------------------------	--------------------------------	------

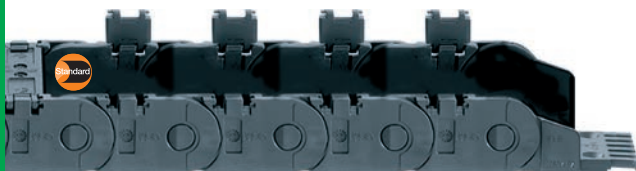

## E2/000 e-chains® Standard for System E2

snap-open along outer  
radius from both sides

1500	21	15 - 125	28,5 - 138,5	28	35 - 180	1,75	246
2500	25	25 - 125	41 - 141	35	55 - 250	2,25	258
2700	35	50 - 175	66 - 194	50	63 - 250	2,75	270
3500	45	50 - 250	70 - 270	64	75 - 300	3,00	282
255	24	38 - 103	54 - 119	35	55 - 250	1,80	294

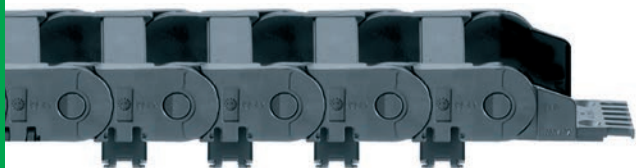

## E2/000 e-chains®

snap-open along inner  
radius from both sides

1400	21	15 - 125	28,5 - 138,5	28	35 - 180	1,75	246
2400	25	25 - 125	41 - 141	35	55 - 250	2,25	258
2600	35	50 - 175	66 - 194	50	63 - 250	2,75	270
3400	45	50 - 250	70 - 270	64	75 - 300	3,00	282



## Half e-tubes

snap-open along inner  
radius from both sides

1450	21	15 - 125	28,5 - 138,5	28	75 - 180	1,75	252
2450	25	25 - 125	41 - 141	35	75 - 250	2,25	264
2650	35	50 - 175	66 - 194	50	100 - 250	2,75	276
3450	45	50 - 250	70 - 270	64	125 - 300	3,00	288

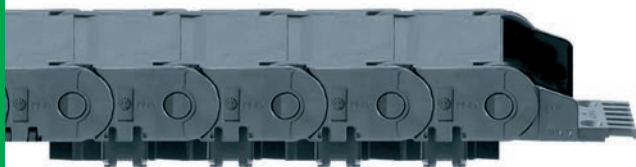

## Full e-tubes

snap-open along inner  
radius from both sides

1480	21	15 - 125	28,5 - 138,5	28	75 - 180	1,75	252
2480	25	25 - 125	41 - 141	35	75 - 250	2,25	264
2680	35	50 - 175	66 - 194	50	100 - 250	2,75	276
3480	45	50 - 250	70 - 270	64	125 - 300	3,00	288

## Technical Data



Gliding speed / acceleration (maximum) max. 10 [m/s] / max. 50 [m/s<sup>2</sup>]

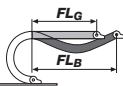

Speed / acceleration  $FL_G$  max. max. 20 [m/s] / max. 200 [m/s<sup>2</sup>]

Speed / acceleration  $FL_B$  max. max. 3 [m/s] / max. 6 [m/s<sup>2</sup>]



Material - permitted temperature °C, igumid G / GLW 40° up to +100° C



Flammability class, igumid G / GLW VDE 0304 IIC UL94-HB

■  $FL_G$  = with straight upper run ■  $FL_B$  = with permitted sag

## Installation methods overview, maximum travels

e-chain® / e-tube Series	Unsupported application	Gliding application	Vertical hanging	Vertical standing	Side mounted unsupported	Rotary application	Zig-zag application	Unsupp. length of lower run
1400/1500/1450/1480	≤ 1,75 m	≤ 75 m	≤ 20 m	≤ 2,0 m	≤ 0,7 m	with rework	upon request	upon request
2400/2500/2450/2480	≤ 2,25 m	≤ 100 m	≤ 40 m	≤ 3,0 m	≤ 1,0 m	with rework	upon request	upon request
2600/2700/2650/2680	≤ 2,75 m	≤ 120 m	≤ 50 m	≤ 3,0 m	≤ 1,0 m	with rework	upon request	upon request
3400/3500/3450/3480	≤ 3,00 m	≤ 150 m	≤ 80 m	≤ 3,0 m	≤ 1,0 m	with rework	upon request	upon request
255	≤ 1,80 m	≤ 100 m	≤ 40 m	≤ 3,0 m	≤ 1,0 m	with rework	upon request	upon request

# E2/000 | Order keys and Options

## Options with order keys | based on Series 2400/2500/2450/2480



Standard

Additional noise dampening with pads

NC-Version - (no camber) without pretension

Reverse bending radius for circular movements

Part No.  
Standard  
e-chains®/e-tubes



Part No.  
Low noise (with pads)  
e-chains®/e-tubes



Part No.  
NC-Version  
e-chains®/e-tubes



Part No.  
RBR  
e-chains®/e-tubes



2400.03.R.0

e-chain® snap-open along inner radius\*

S2400.03.R.0

e-chain® snap-open along inner radius\*

2400.03.R.0.NC

e-chain® snap-open along inner radius\*

2400.03.R1/R2.0

e-chain® snap-open along inner radius\*

2500.03.R.0

e-chain® snap-open along outer radius

S2450.03.R.0

Half e-tube snap-open along inner radius\*

2500.03.R.0.NC

e-chain® snap-open along outer radius

2500.03.R1/R2.0

e-chain® snap-open along outer radius

2450.03.R.0

Half e-tube snap-open along inner radius\*

S2480.03.R.0

e-tube snap-open along inner radius\*

2450.03.R.0.NC

Half e-tube snap-open along inner radius\*

2450.03.R1/R2.0<sup>1)</sup>

Half e-tube snap-open along inner radius\*

2480.03.R.0

e-tube snap-open along inner radius\*

2480.03.R.0.NC

e-tube snap-open along inner radius\*

2480.03.R1/R2.0<sup>1)</sup>

e-tube snap-open along inner radius\*



Delivery from stock

Delivery time: upon request

Delivery time: upon request

Delivery time: upon request

\* Before using this Series in gliding applications, please consult igus®

1) Available upon request, please consult igus® for delivery time!

## Order example | based on Series 2400/2500/2450/2480



Order example for complete e-chain® (1,0 m), color black, with mounting brackets and interior separation:

e-chain® (1,0 m) Please indicate e-chain® length or number of links: 1,0 m or 22 links **2500.03.100.0**

+ Mounting brackets 1 set (with tiwrap plates) **2030.34PZB+**

+ Interior separation with 2 separators assembled every 2<sup>nd</sup> link **2 x 211**

Order text: 1,0 m 2500.03.100.0 + 2100.34PZB + 2 x Part No. 211

### Magnetically detectable plastic e-chains®

For the food- and tobaccoindustry | **New** in this catalog

● The material igumid DT is detected to the tiniest fragment all common metal detection systems and can therefore be selected automatically ● Particles as small as 1.0 mm can be recognized for fragments passing at speeds of 20 m/min

Further Information ► [www.igus.eu/eu/detectable-chain](http://www.igus.eu/eu/detectable-chain)



# E2/000 | Order keys and Options

Unsupported lengths +25% possible

Part No.  
**XXL-Material<sup>2)</sup>**  
e-chains/e-tubes



**2400.03.R.0.XXL**

e-chain\* snap-open along inner radius\*

**2500.03.R.0.XXL**

e-chain\* snap-open along outer radius

**2450.03.R.0.XXL**

Half e-tube snap-open along inner radius\*

**2480.03.R.0.XXL**

e-tube snap-open along inner radius\*

**Delivery time:  
upon request**

No burning-in of hot chips up to 850°C (1562°F)

Part No.  
**igumid HT-Material**  
only for e-tubes



**2480/2450.03.R.0.HT**

Complete e-tube\*

**2480/2450.03.HT.R.0**

Bottom only\*

**Delivery time:  
upon request**

ESD / ATEX classified e-chains®  
**Ex II 2 GD**

Part No.  
**ESD-Material**  
e-chains®/e-tubes



**2400.03.R.0.ESD**

e-chain\* snap-open along inner radius\*

**2500.03.R.0.ESD**

e-chain\* snap-open along outer radius

**2450.03.R.0.ESD**

Half e-tube snap-open along inner radius\*

**2480.03.R.0.ESD**

e-tube snap-open along inner radius\*

**Delivery time:  
Several series  
from stock**

Magnetically detectable plastic e-chains® for the food- and tobacco industry

Part No.  
**igumid DT-Material**  
e-chains®/e-tubes



**2400.03.R.0.DT**

e-chain\* snap-open along inner radius\*

**2500.03.R.0.DT**

e-chain\* snap-open along outer radius

**2450.03.R.0.DT**

Half e-tube snap-open along inner radius\*

**2480.03.R.0.DT**

e-tube snap-open along inner radius\*

**Delivery time  
upon request**

\* Before using this Series for gliding applications, please consult igus®  
2) Lower part made of XXL-Material

## Order key and color options | based on Series 2400/2500/2450/2480



### Order key

- e-chain\* snap-open along outer radius
- e-chain\* snap-open along inner radius
- Half e-tube snap-open along inner radius
- Full e-tube snap-open along inner radius

**2500.03.100.0**  
**2400.03.100.0**  
**2450.03.100.0**  
**2480.03.100.0**

- Series / Type
- Width index (depends on *Bi*)
- Bending radius *R*
- Color index (standard black)



### General igus® color options for e-chains® and e-tubes

Color	Order index	Color	Order index
Black Standard, from stock!	.0	White special color	.1
Slate grey only ESD material	.ESD	Gray white special color	.1S
Gray brown only HT material	.HT	Orange special color	.2
Gray special color only e-chains®	.3	Yellow special color	.4
Dusty grey special color only e-tubes	.31	Light grey special color	.14

**Black e-chains® available from stock!**

**Delivery time for special colors: upon request**

**2500.03.100.0** = e-chain\* snap-open along outer radius, *Bi* 38 mm inner width, *R* 100 mm radius, color black

**2400.03.100.0** = e-chain\* snap-open along inner radius, *Bi* 38 mm inner width, *R* 100 mm radius, color black

**2450.03.100.0** = Half e-tube snap-open along inner radius, *Bi* 38 mm inner width, *R* 100 mm radius, color black

**2480.03.100.0** = Full e-tube snap-open along inner radius, *Bi* 38 mm inner width, *R* 100 mm radius, color black

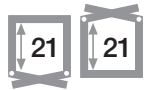

e-chains® | Series 1400 snap-open along inner radius

e-chains® | Series 1500 snap-open along outer radius

e-chains® snap-open along inner radius	e-chains® snap-open along outer radius		<i>Bi</i> [mm]	<i>Ba</i> [mm]	<i>R</i> Bending radii [mm]								1400 [kg/m]	1500 [kg/m]
1400. 015 . <i>R</i> .0	1500. 015 . <i>R</i> .0		15	28,5	035	038	048	075	100	125	145	180	≈ 0,46	≈ 0,46
1400. 020 . <i>R</i> .0	1500. 020 . <i>R</i> .0		20	33,5	035	038	048	075	100	125	145	180	≈ 0,47	≈ 0,47
1400. 025 . <i>R</i> .0	1500. 025 . <i>R</i> .0		25	38,5	035	038	048	075	100	125	145	180	≈ 0,49	≈ 0,49
1400. 038 . <i>R</i> .0	1500. 038 . <i>R</i> .0		38	51,5	035	038	048	075	100	125	145	180	≈ 0,53	≈ 0,53
1400. 050 . <i>R</i> .0	1500. 050 . <i>R</i> .0		50	63,5	035	038	048	075	100	125	145	180	≈ 0,56	≈ 0,56
1400. 068 . <i>R</i> .0	1500. 068 . <i>R</i> .0		68	81,5	035	038	048	075	100	125	145	180	≈ 0,63	≈ 0,63
1400. 080 . <i>R</i> .0	1500. 080 . <i>R</i> .0		80	93,5	035	038	048	075	100	125	145	180	≈ 0,67	≈ 0,67
1400. 100 . <i>R</i> .0	1500. 100 . <i>R</i> .0		100	113,5	035	038	048	075	100	125	145	180	≈ 0,74	≈ 0,74
1400. 125 . <i>R</i> .0	1500. 125 . <i>R</i> .0		125	138,5	035	038	048	075	100	125	145	180	≈ 0,83	≈ 0,83

Half e-tubes, Series 1450 and full e-tubes Series 1480 ► from page 252

Supplement Part No. with required radius. Example: 1500.038.100.0



ESD/ATEX permanently conductive e-chains® - 1500 several widths with delivery from stock:  
Inner widths *Bi* 15 - 80, radii *R* 38 - 145. Full ESD delivery program ► [www.igus.eu/eu/ESD](http://www.igus.eu/eu/ESD)

### Open e-chains® in a flash with the igus® e-chain® opener

Reduce assembly time from 33 to 2 sec. with the igus® e-chain® Opener. Open a long piece of e-chain® in one go. Part No. 908.254.1400 for Series 1400/1500. For widths *Bi* [mm]: 20, 50, 68, 80, 100.

Further information and video ► [www.igus.eu/eu/savetime](http://www.igus.eu/eu/savetime)







Unsupported applications | Short travels

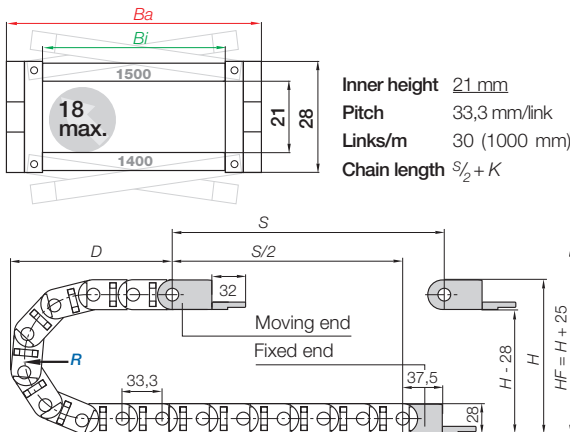
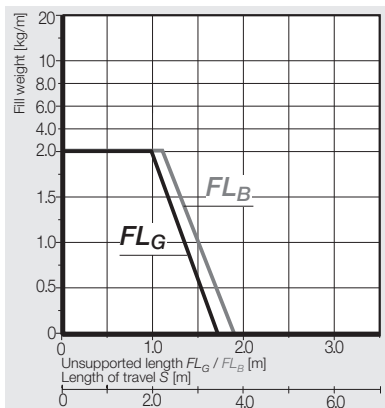

Inner height 21 mm  
Pitch 33,3 mm/link  
Links/m 30 (1000 mm)  
Chain length  $\frac{S}{2} + K$

R	035	038	048	075	100	125	145	180
H	98	104	124	178	228	278	318	388
D	99	102	112	139	164	189	209	244
K	180	190	220	305	385	460	525	635

The required clearance height:  $H_F = H + 25$  mm (with 0,5 kg/m fill weight)

Before using Series 1400 on long travels please consult igus®.

Gliding applications | Long travels from 10 m to max. 75 m

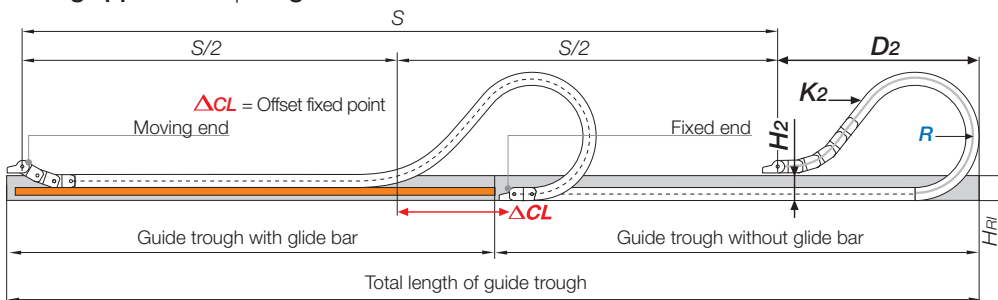

**Note:** For using Series 1400 for long travels (gliding), please consult with igus® first.

For long travels, igus® specifies **Series 1500** that snaps open along the outer radius.

In case of travels between 4 and 10 m we recommend a longer unsupported length. **Chain length**  $\frac{S}{2} + K_2$

R	035	038	048	075	100	125	145	180
H <sub>2</sub>	70	76	96	150	100	100	100	100
D <sub>2</sub> +25	99	102	112	139	340	495	540	690
K <sub>2</sub>	180	190	220	305	600	800	940	1170
ΔCL	-	-	-	-	179	305	340	445

Before using Series 1400 on long travels please consult igus®.

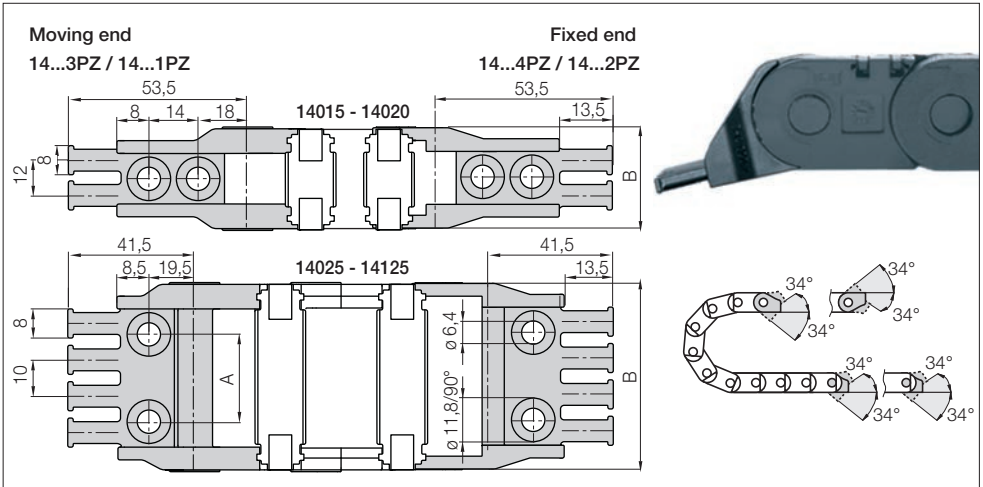

**Polymer pivoting** | Standard | Recommended for unsupported and gliding applications  
**Polymer locking** | Recommended for vertical hanging and standing applications

Width Index	Part No. full set <b>pivoting:</b> with tiewrap plates	Part No. full set <b>locking:</b> with tiewrap plates	Dim A [mm]	Dim B [mm]	Number of teeth
.015. ▶	14015.34PZ	14015.12PZ	–	28,5	2
.020. ▶	14020.34PZ	14020.12PZ	–	33,5	2
.025. ▶	14025.34PZ	14025.12PZ	13	38,5	2
.038. ▶	14038.34PZ	14038.12PZ	24	51,5	4
.050. ▶	14050.34PZ	14050.12PZ	36	63,5	5
.068. ▶	14068.34PZ	14068.12PZ	54	81,5	7
.080. ▶	14080.34PZ	14080.12PZ	66	93,5	8
.100. ▶	14100.34PZ	14100.12PZ	86	113,5	10
.125. ▶	14125.34PZ	14125.12PZ	111	138,5	13

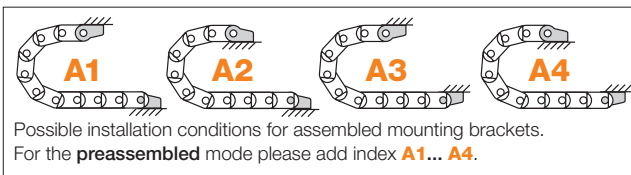

Part No. structure  
**14038. 34 PZ A1**

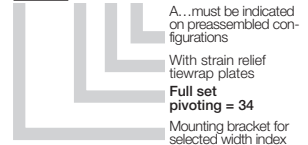

**Strain relief** e.g. clamps, tiewrap plates, nuggets and plug-in clips are available from stock. The complete chainfix range with order options ▶ from page 630

## Mounting brackets, polymer | pivoting

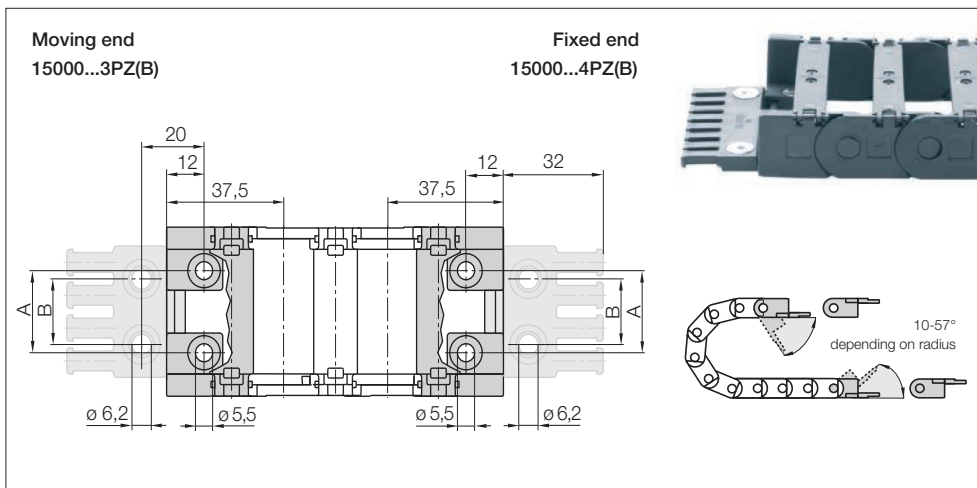

## Polymer pivoting | Recommended for unsupported and gliding applications For tight installation conditions

Width Index	Part No. full set pivoting:		Dim A [mm]	Dim B [mm]	Number of teeth
	with tiwrap plates	without tiwrap plates			
.015. ▶	-	-	-	-	-
.020. ▶	-	-	-	-	-
.025. ▶	15000.025.34PZB	15000.025.34PZ	12	15	3
.038. ▶	15000.038.34PZB	15000.038.34PZ	25	20	4
.050. ▶	15000.050.34PZB	15000.050.34PZ	37	30	5
.068. ▶	15000.068.34PZB	15000.068.34PZ	55	40	6
.080. ▶	15000.080.34PZB	15000.080.34PZ	67	60	8
.100. ▶	15000.100.34PZB	15000.100.34PZ	87	80	10
.125. ▶	15000.125.34PZB*	15000.125.34PZ*	112	100	12

\*Tiewrap plate (consists of 2 x 2050.ZB) does not snap on but needs to be bolted down separately

**Note:** Mounting brackets not to assemble at the gable end

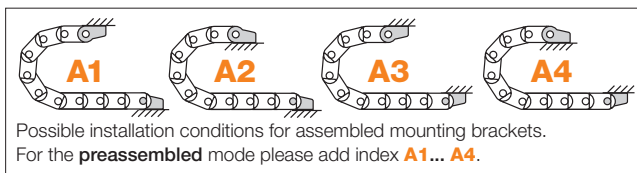

Part No. structure

15000.038.34PZ**A1**

A... must be indicated on preassembled configurations

With strain relief tiwrap plates

Full set pivoting = 34

Mounting bracket for selected width index

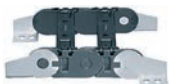

Option: Steel locking Part No. 14000.12 - For e-chains® and e-tubes available

- Locked connections
- One part (2-piece) for all e-chain® widths
- Electrically conductive



**Strain relief** e.g. clamps, tiwrap plates, nuggets and plug-in clips are available from stock. The complete chainfix range with order options ▶ from page 630

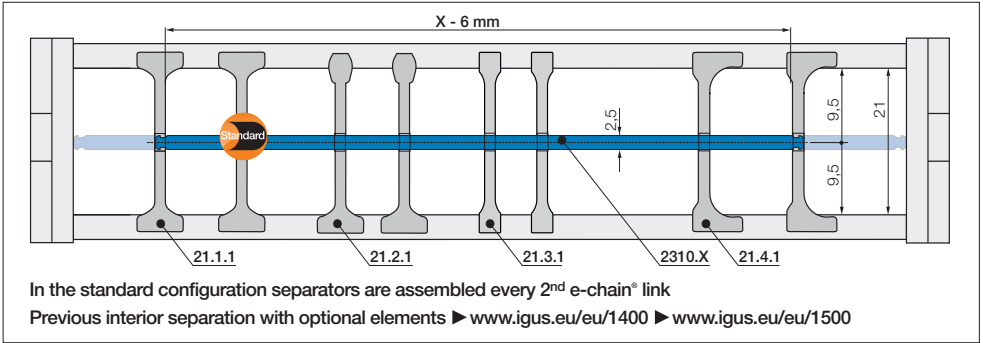

**Standard separator, wide base**

unassembled	<b>21.1</b>
assembled	<b>21.1.1</b>

### Standard - for all applications

Separator with wide base for maximum locking strength and safe standing in e-chains®.

**Separator, narrow head**

unassembled	<b>21.2</b>
assembled	<b>21.2.1</b>

### For even faster installation

Firm hold to one side with a wide base, narrow on opposed side for easy cable assembly (slight grip).

**Separator, narrow base**

unassembled	<b>21.3</b>
assembled	<b>21.3.1</b>

### For many thin cables

Separator with a narrow base for a large number of thin cables side by side. Saves space in e-chains®.

**Separator, asymmetrical**

unassembled	<b>21.4</b>
assembled	<b>21.4.1</b>

### For side-mounted applications

Asymmetrical separator, for defined distance. No additional spacers necessary.

**Full-width shelf, lockable**

unassembled	<b>2300.X</b>
assembled	<b>2310.X</b>

### Horizontal separation

Full-width shelf locks safely into separators on both ends, fixed width possible. Separators can be moved freely over the shelf in horizontal direction. Can be used at one height.

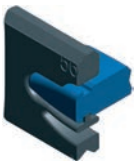

### Lockable full-width shelves - for the standard interior separation

Width X [mm]	unassembled	assembled	Width X [mm]	unassembled	assembled	Width X [mm]	unassembled	assembled
015	2300.015	2310.015	060	2300.060	2310.060	087	2300.87	2310.087
025	2300.025	2310.025	062	2300.062	2310.062	090	2300.90	2310.090
030	2300.030	2310.030	065	2300.065	2310.065	100	2300.100	2310.100
038	2300.038	2310.038	070	2300.070	2310.070	103	2300.103	2310.103
040	2300.040	2310.040	075	2300.075	2310.075	110	2300.110	2310.110
050	2300.050	2310.050	077	2300.077	2310.077	120	2300.120	2310.120
057	2300.057	2310.057	080	2300.080	2310.080	125	2300.125	2310.125



E2/000 Series 1400 in aircraft refuelling truck; telescopic crane with six sections

### Separator with integrated strain relief

Strain relief separator Part No. 21.1.Z can be integrated into the mounting bracket and can be placed there at any point of the e-chain®. It combines strain relief and interior separation, it can be installed on the first or last chain link and is easy to assemble without any screws. **Further Information ► from page 650**



### Optional: Support tray tool kit.

#### For support of the lower run.

Simple one-piece support trays according to your requirements and specification.

The complete range with order options ► from page 714



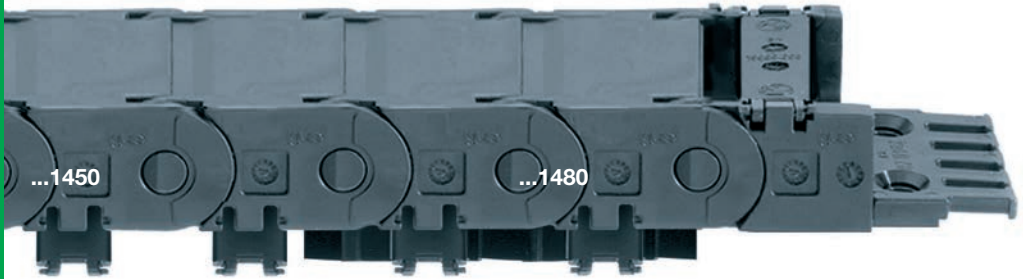

Half e-tubes | Series 1450 snap-open along inner radius, closed along outer radius  
Full e-tubes | Series 1480 snap-open along inner radius, fully enclosed

Half e-tubes snap-open along inner radius	Full e-tubes snap-open along inner radius	<i>Bi</i> [mm]	<i>Ba</i> [mm]	<i>R</i> Bending radii [mm]	1450 [kg/m]	1480 [kg/m]
1450. 015. <i>R</i> .0	1480. 015. <i>R</i> .0	15	28,5	035*   038*   048*   075   100   125   145   180	≈ 0,48	≈ 0,50
1450. 020. <i>R</i> .0**	1480. 020. <i>R</i> .0**	20	33,5	035*   038*   048*   075   100   125   145   180	≈ 0,51	≈ 0,51
1450. 025. <i>R</i> .0	1480. 025. <i>R</i> .0	25	38,5	035*   038*   048*   075   100   125   145   180	≈ 0,54	≈ 0,57
1450. 038. <i>R</i> .0	1480. 038. <i>R</i> .0	38	51,5	035*   038*   048*   075   100   125   145   180	≈ 0,59	≈ 0,61
1450. 050. <i>R</i> .0	1480. 050. <i>R</i> .0	50	63,5	035*   038*   048*   075   100   125   145   180	≈ 0,65	≈ 0,67
1450. 068. <i>R</i> .0	1480. 068. <i>R</i> .0	68	81,5	035*   038*   048*   075   100   125   145   180	≈ 0,74	≈ 0,77
1450. 080. <i>R</i> .0	1480. 080. <i>R</i> .0	80	93,5	035*   038*   048*   075   100   125   145   180	≈ 0,80	≈ 0,84
1450. 100. <i>R</i> .0	1480. 100. <i>R</i> .0	100	113,5	035*   038*   048*   075   100   125   145   180	≈ 0,90	≈ 0,95
1450. 125. <i>R</i> .0	1480. 125. <i>R</i> .0	125	138,5	035*   038*   048*   075   100   125   145   180	≈ 1,03	≈ 1,08

\*\*Width available upon request, please consult igus\* for delivery time

\*Radius available upon request, please consult igus\* for delivery time

For radii 035, 038, 048 the e-tube is not fully enclosed. Please consult igus\*.

Supplement Part No. with required radius. Example: 1450.038.100.0

### Open e-chains® in a flash with the igus® e-chain® opener

Reduce assembly time from 33 to 2 sec. with the igus® e-chain® Opener. Open a long piece of e-chain® in one go. Part No. 908.254.1400 for Series 1450. For widths *Bi* [mm]: 20, 50, 68, 80, 100.

Further information and video ► [www.igus.eu/eu/savetime](http://www.igus.eu/eu/savetime)





## Unsupported applications | Short travels

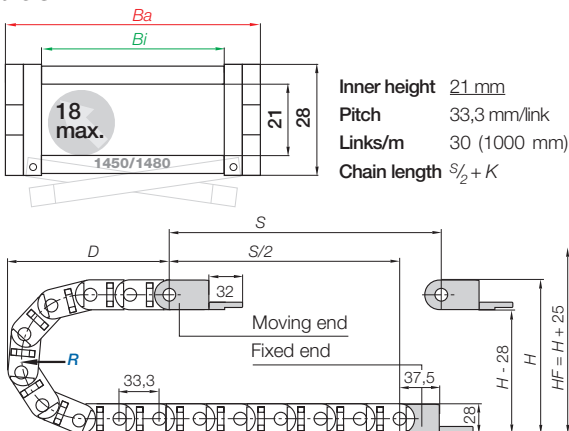
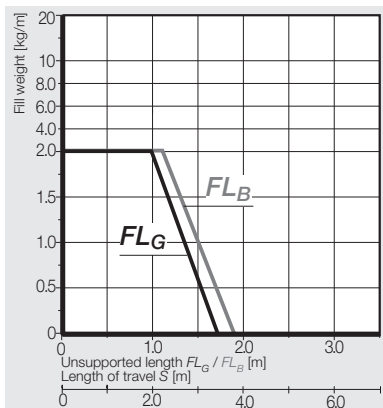

R	035*	038*	048*	075	100	125	145	180
H	98	104	124	178	228	278	318	388
D	99	102	112	139	164	189	209	244
K	180	190	220	305	385	460	525	635

The required clearance height:  $H_F = H + 25$  mm (with 0,5 kg/m fill weight)

\*Radius available upon request, please consult igus\* for delivery time Before using Series 1450/1480 on long travels please consult igus\*.

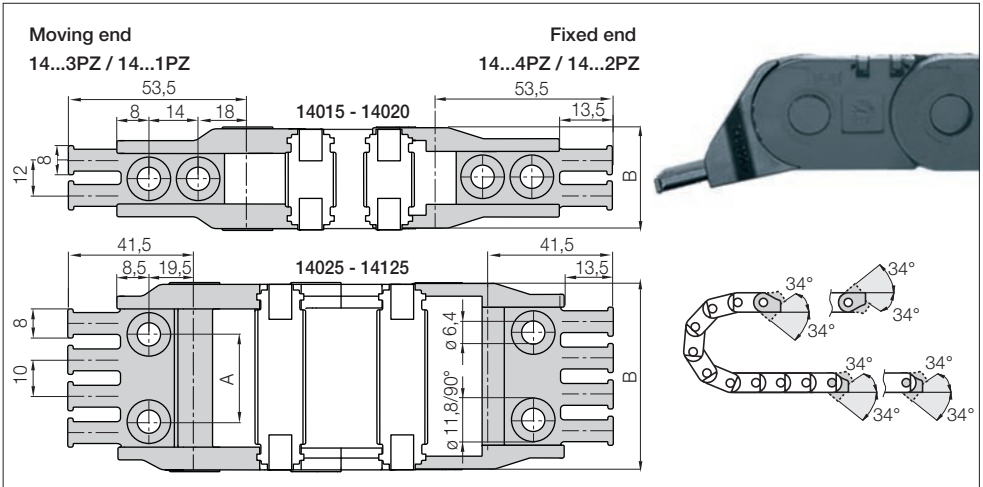

**Polymer pivoting** | Standard | Recommended for unsupported applications

**Polymer locking** | Recommended for vertical hanging and standing applications

Width Index	Part No. full set <b>pivoting:</b> with tiewrap plates	Part No. full set <b>locking:</b> with tiewrap plates	Dim A [mm]	Dim B [mm]	Number of teeth
.015. ▶	14015.34PZ	14015.12PZ	–	28,5	2
.020. ▶	14020.34PZ	14020.12PZ	–	33,5	2
.025. ▶	14025.34PZ	14025.12PZ	13	38,5	2
.038. ▶	14038.34PZ	14038.12PZ	24	51,5	4
.050. ▶	14050.34PZ	14050.12PZ	36	63,5	5
.068. ▶	14068.34PZ	14068.12PZ	54	81,5	7
.080. ▶	14080.34PZ	14080.12PZ	66	93,5	8
.100. ▶	14100.34PZ	14100.12PZ	86	113,5	10
.125. ▶	14125.34PZ	14125.12PZ	111	138,5	13

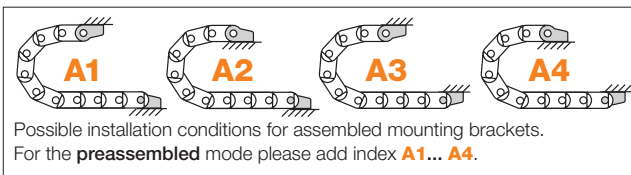

Part No. structure

14038. 34 PZ **A1**

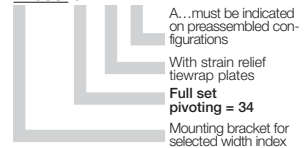

 **Strain relief** e.g. clamps, tiewrap plates, nuggets and plug-in clips are available from stock. The complete chainfix range with order options ▶ from page 630



## Mounting brackets, polymer | pivoting

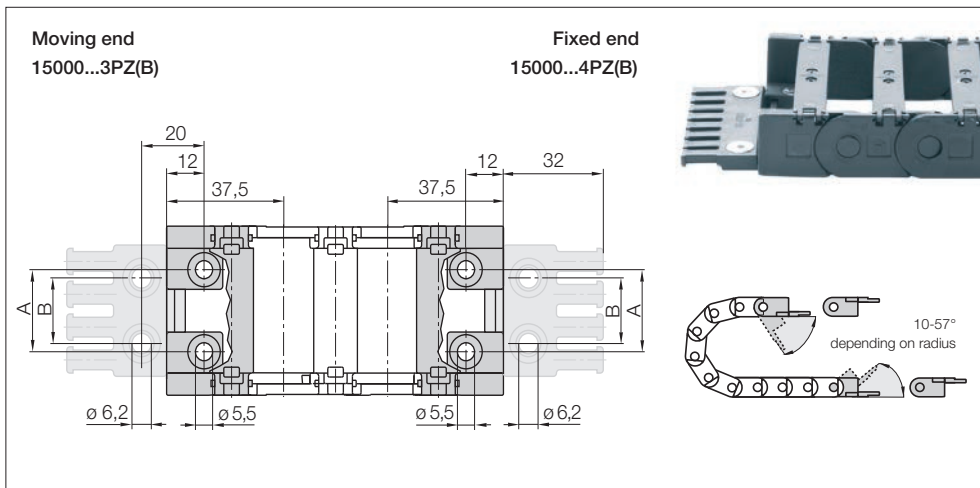

### Polymer pivoting | Recommended for unsupported applications

#### For tight installation conditions

Width Index	Part No. full set pivoting:		Dim A [mm]	Dim B [mm]	Number of teeth
	with tiwrap plates	without tiwrap plates			
.015. ▶	-	-	-	-	-
.020. ▶	-	-	-	-	-
.025. ▶	15000.025.34PZB	15000.025.34PZ	12	15	3
.038. ▶	15000.038.34PZB	15000.038.34PZ	25	20	4
.050. ▶	15000.050.34PZB	15000.050.34PZ	37	30	5
.068. ▶	15000.068.34PZB	15000.068.34PZ	55	40	6
.080. ▶	15000.080.34PZB	15000.080.34PZ	67	60	8
.100. ▶	15000.100.34PZB	15000.100.34PZ	87	80	10
.125. ▶	15000.125.34PZB*	15000.125.34PZ*	112	100	12

\*Tiewrap plate (consists of 2x2050.ZB) does not snap on but needs to be bolted down separately

**Note:** Mounting brackets not to assemble at the gable end

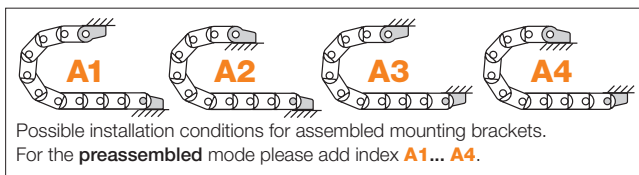

#### Part No. structure

**15000.038.34PZA1**

A... must be indicated on preassembled configurations

With strain relief tiwrap plates

Full set pivoting = 34

Mounting bracket for selected width index

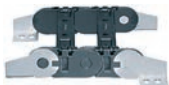

Option: Steel locking Part No. 14000.12 - For e-chains® and e-tubes available

- Locked connections
- One part (2-piece) for all e-chain® widths
- Electrically conductive



**Strain relief** e.g. clamps, tiwrap plates, nuggets and plug-in clips are available from stock. The complete chainfix range with order options ▶ from page 630

Interior separation

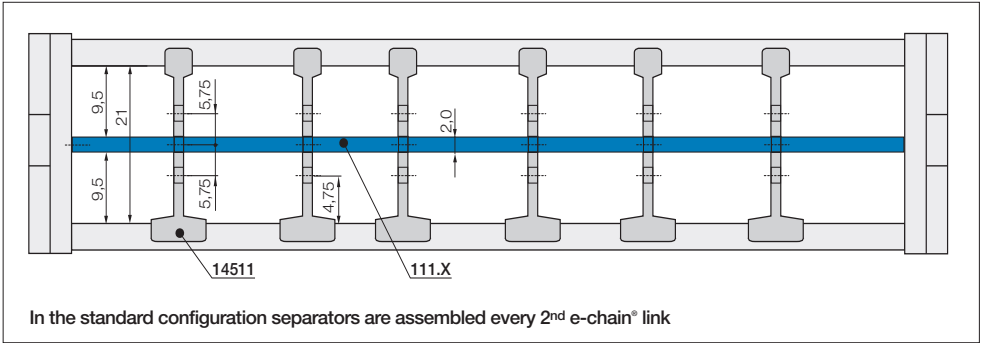

**Slotted separator for e-tubes**  
 unassembled **14501**  
 assembled **14511**

**Slotted separator 14501**

is used when vertical and horizontal separation is required. Due to its slot, it allows basic vertical/horizontal shelving arrangements.

**Full-width shelf for e-tubes**  
 unassembled **110.X**  
 assembled **111.X**

**Full-width shelf 110.X**

this option makes sense in applications with many thin cables with similar diameters. For a consequent subdivision. Full-width shelves can be arranged at 3 different heights (in 5,75 mm increments).

**Full-width shelves**

Width X [mm]	unassembled	assembled	Width X [mm]	unassembled	assembled	Width X [mm]	unassembled	assembled
015	110.15	111.15	038	110.38	111.38	080	110.80	111.80
020	110.20	111.20	050	110.50	111.50	100	110.100	111.100
025	110.25	111.25	068	110.68	111.68	125	110.125	111.125



Installation-optimized delivery of an igus® readychain®- here system E2/000

**Optional: Support tray tool kit.**

**For support of the lower run.**

Simple one-piece support trays according to your requirements and specification.

The complete range with order options ► from page 714



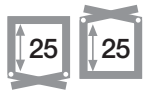

Allrounder, high stability

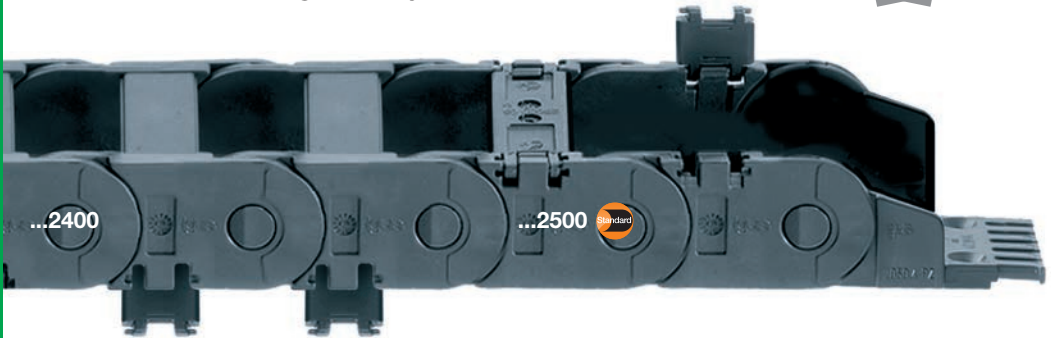

e-chains® | Series 2400 snap-open along inner radius

e-chains® | Series 2500 snap-open along outer radius

e-chains® snap-open along inner radius	e-chains® snap-open along outer radius	 <i>Bi</i> [mm]	<i>Ba</i> [mm]	<i>R</i> Bending radii [mm]	2400 [kg/m]	2500 [kg/m]
2400.02 .R.0	2500.02 .R.0	25	41	055   075   100   125   150   175   200   225   250	≈ 0,77	≈ 0,77
2400.03 .R.0	2500.03 .R.0	38	54	055   075   100   125   150   175   200   225   250	≈ 0,83	≈ 0,83
2400.05 .R.0	2500.05 .R.0	57	73	055   075   100   125   150   175   200   225   250	≈ 0,91	≈ 0,91
2400.07 .R.0	2500.07 .R.0	77	93	055   075   100   125   150   175   200   225   250	≈ 1,01	≈ 1,01
2400.09 .R.0	2500.09 .R.0	89	105	055   075   100   125   150   175   200   225   250	≈ 1,08	≈ 1,08
2400.10 .R.0	2500.10 .R.0	103	119	055   075   100   125   150   175   200   225   250	≈ 1,15	≈ 1,15
2400.12 .R.0	2500.12 .R.0	125	141	055   075   100   125   150   175   200   225   250	≈ 1,22	≈ 1,22

Half e-tubes, Series 2450 and full e-tubes Series 2480 ► from page 264

Supplement Part No. with required radius. Example: 2500.03.100.0

ESD/ATEX permanently conductive e-chains® - 2500 several widths with delivery from stock:  
Inner widths *Bi* 25 - 125, radii *R* 055 - 175. Full ESD delivery program ► [www.igus.eu/eu/ESD](http://www.igus.eu/eu/ESD)

## Open e-chains® in a flash with the igus® e-chain® opener

Reduce assembly time from 33 to 2 sec. with the igus® e-chain® Opener. Open a long piece of e-chain® in one go. Part No. 908.254.2400 for Series 2400/2500.

For widths *Bi* [mm]: 05, 07, 09Further information and video ► [www.igus.eu/savetime](http://www.igus.eu/savetime)



## Unsupported applications | Short travels

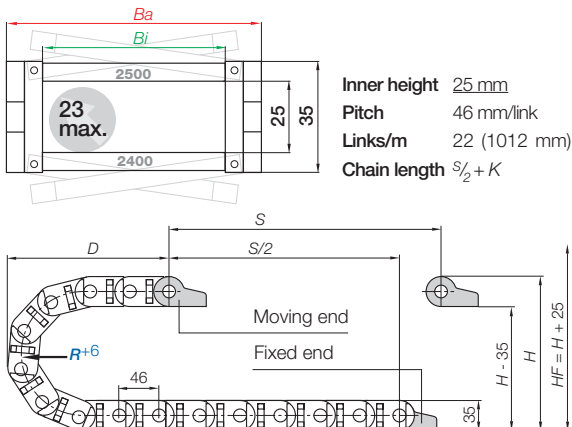
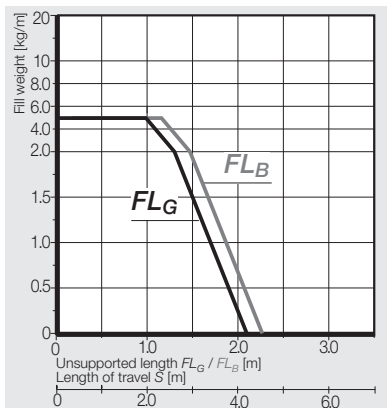

Inner height 25 mm  
Pitch 46 mm/link  
Links/m 22 (1012 mm)  
Chain length  $S/2 + K$

R	055	075	100	125	150	175	200	225	250
H	145	185	235	285	335	385	435	485	535
D	142	162	187	212	237	262	287	312	337
K	265	330	410	485	565	645	725	800	880

The required clearance height:  $H_F = H + 25$  mm (with 1,5 kg/m fill weight)

Before using Series 2400 on long travels please consult igus®.

## Gliding applications | Long travels from 10 m to max. 100 m

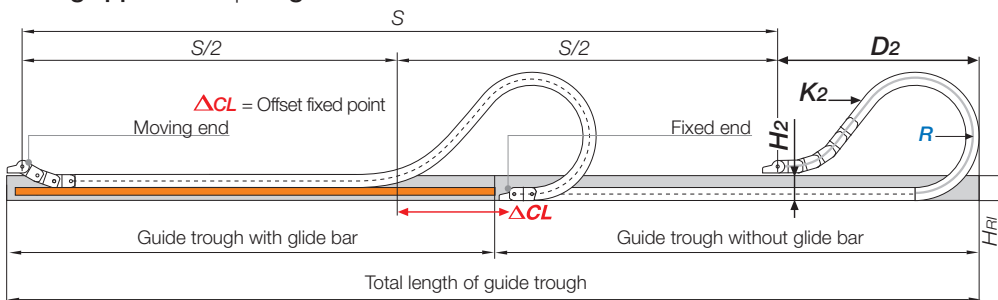

**Note:** For using Series 2400 for long travels (gliding), please consult with igus® first.

For long travels, igus® specifies **Series 2500** that snaps open along the outer radius.

In case of travels between 4 and 10 m we recommend a longer unsupported length. **Chain length**  $S/2 + K_2$

R	055	075	100	125	150	175	200	225	250
$H_2$	110	150	100	100	100	100	100	100	100
$D_2^{+25}$	142	162	380	440	590	755	950	1040	1130
$K_2$	265	330	644	736	1012	1242	1472	1610	1794
$\Delta CL$	-	-	204	244	364	504	674	754	804

Before using Series 2400 on long travels please consult igus®.

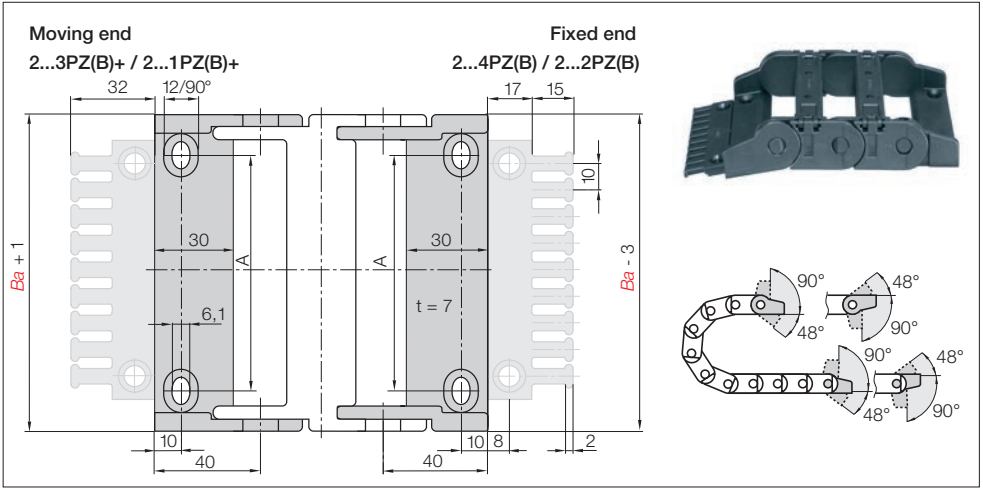

**Polymer pivoting** | Standard | Recommended for unsupported and gliding applications  
**Polymer locking** | Recommended for vertical hanging and standing applications

Width Index	standard	Part No. full set <b>pivoting</b> :		Part No. full set <b>locking</b> :		Dim A [mm]	Number of teeth
		with tiewrap plates	without tiewrap plates	with tiewrap plates	without tiewrap plates		
.02.	▶	2020.34PZB+	2020.34PZ+	2020.12PZB+	2020.12PZ+	12	3
.03.	▶	2030.34PZB+	2030.34PZ+	2030.12PZB+	2030.12PZ+	25	4
.05.	▶	2050.34PZB+	2050.34PZ+	2050.12PZB+	2050.12PZ+	44	6
.07.	▶	2070.34PZB+	2070.34PZ+	2070.12PZB+	2070.12PZ+	64	8
.09.	▶	2090.34PZB+	2090.34PZ+	2090.12PZB+	2090.12PZ+	77	9
.10.	▶	2100.34PZB+	2100.34PZ+	2100.12PZB+	2100.12PZ+	90	10
.12.	▶	2125.34PZB+	2125.34PZ+	2125.12PZB+	2125.12PZ+	112	12

Full set with tiewrap plate + 10 cable tiewraps, please add index **K1+** ▶ e.g. 2020.34PZBK1+

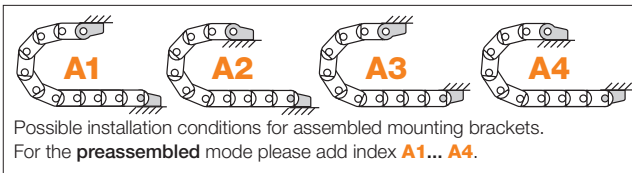

Part No. structure

2020.34 PZB+ A1

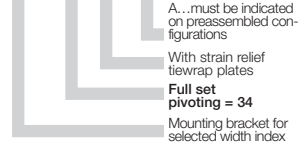

**Strain relief** e.g. clamps, tiewrap plates, nuggets and plug-in clips are available from stock. The complete chainfix range with order options ▶ from page 630

KMA mounting brackets | Attachment on all sides | pivoting | locking

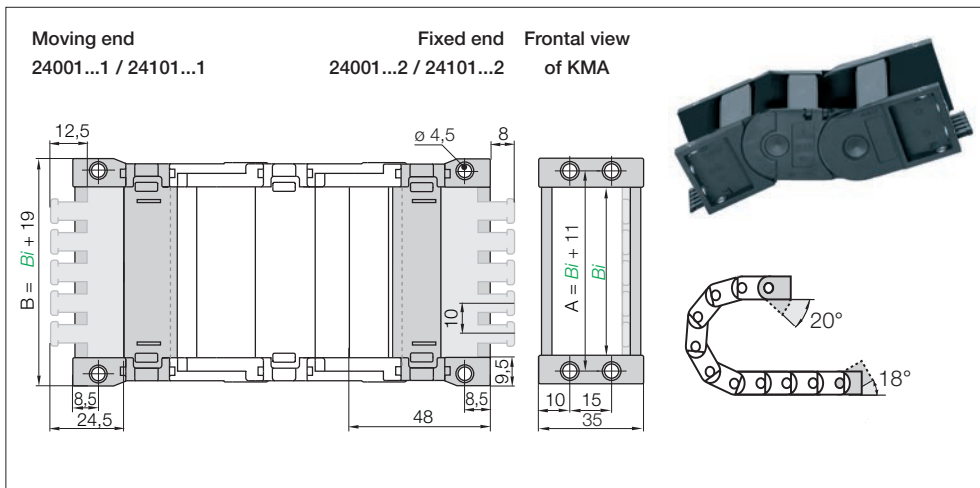

**KMA pivoting** | Recommended for unsupported and gliding applications

**KMA locking** | Recommended for vertical hanging and standing applications

Width Index	Part No. full set <b>KMA pivoting:</b>		Part No. full set <b>KMA locking:</b>		Dim A [mm]	Dim B [mm]	Number of teeth
	with tiewrap plates	without tiewrap plates	with tiewrap plates	without tiewrap plates			
.02.	▶ 24001.02.12ZB	24001.02.12	24101.02.12ZB	24101.02.12	36	44	2
.03.	▶ 24001.03.12ZB	24001.03.12	24101.03.12ZB	24101.03.12	49	57	4
.05.	▶ 24001.05.12ZB	24001.05.12	24101.05.12ZB	24101.05.12	68	76	6
.07.	▶ 24001.07.12ZB	24001.07.12	24101.07.12ZB	24101.07.12	88	86	7
.09.	▶ 24001.09.12ZB	24001.09.12	24101.09.12ZB	24101.09.12	100	108	9
.10.	▶ 24001.10.12ZB	24001.10.12	24101.10.12ZB	24101.10.12	114	122	10
.12.	▶ 24001.12.12ZB	24001.12.12	24101.12.12ZB	24101.12.12	136	144	12

(KMA = Polymer Metal Mounting Bracket)

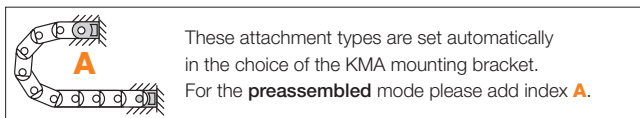

Part No. structure

24001.02.12ZB**A**



Option: Steel **pivoting** Part No. 2000.32 - For e-chains® and e-tubes available

● Pivoting connections ● One part (2-piece) for all e-chain® widths ● Electrically conductive

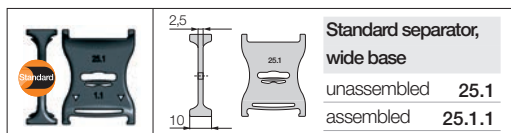
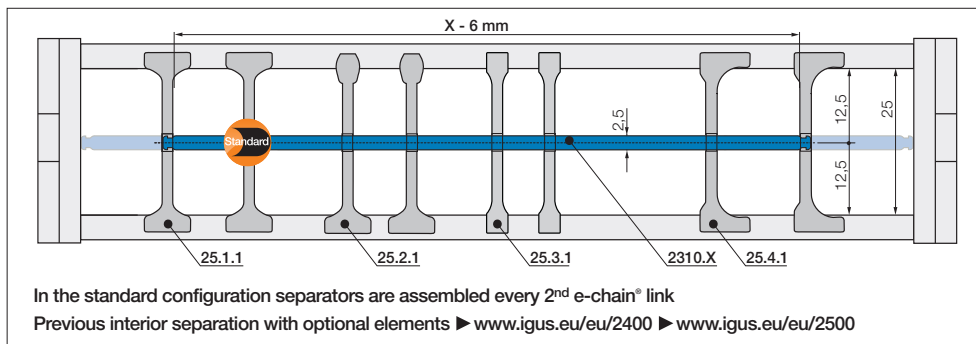

**Strain relief** e.g. clamps, tiewrap plates, nuggets and plug-in clips are available from stock. The complete chainfix range with order options ▶ from page 630

**Standard - for all applications**

Separator with a wide base for maximum locking strength and safe standing in e-chains®.

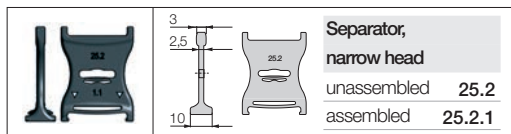
**For even faster installation**

Firm hold to one side with a wide base, narrow on opposed side for easy cable assembly (slight grip).

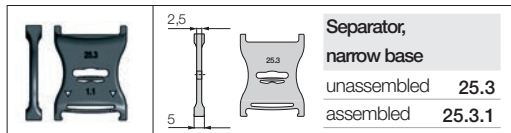
**For many thin cables**

Separator with a narrow base for a large number of thin cables side by side. Saves space in e-chains®.

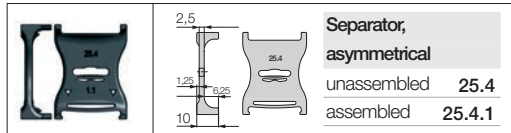
**For side-mounted applications**

Asymmetrical separator, for defined distance. No additional spacers necessary.

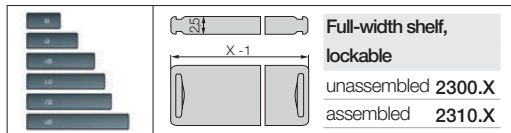
**Horizontal separation**

Full-width shelf locks safely into separators on both ends, fixed width possible. Separators can be moved freely over the shelf in horizontal direction. Can be used at one height.

**Lockable full-width shelves - for the standard interior separation**

Width X [mm]	unassembled	assembled	Width X [mm]	unassembled	assembled	Width X [mm]	unassembled	assembled
015	2300.015	2310.015	060	2300.060	2310.060	087	2300.087	2310.087
025	2300.025	2310.025	062	2300.062	2310.062	090	2300.090	2310.090
030	2300.030	2310.030	065	2300.065	2310.065	100	2300.100	2310.100
038	2300.038	2310.038	070	2300.070	2310.070	103	2300.103	2310.103
040	2300.040	2310.040	075	2300.075	2310.075	110	2300.110	2310.110
050	2300.050	2310.050	077	2300.077	2310.077	120	2300.120	2310.120
057	2300.057	2310.057	080	2300.080	2310.080	125	2300.125	2310.125

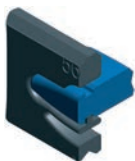



Extender crossbars

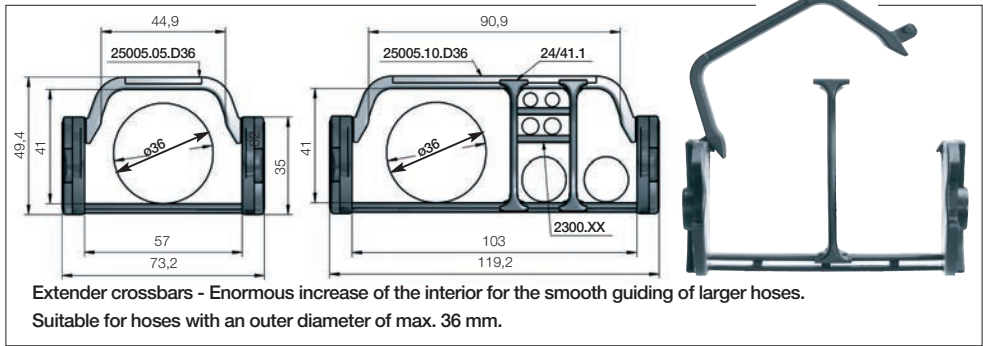

Extender crossbars - Enormous increase of the interior for the smooth guiding of larger hoses.  
Suitable for hoses with an outer diameter of max. 36 mm.

Extender crossbars for e-chains® snap-open along inner radius	Extender crossbars for e-chains® snap-open along outer radius	<i>Bi</i> [mm]	<i>Ba</i> [mm]	<i>R</i> Bending radii
2400.05 D36.R.0	2500.05 D36.R.0	57	73	055* 075 100 125 150 175 200 225 250
2400.10 D36.R.0	2500.10 D36.R.0	103	119	055* 075 100 125 150 175 200 225 250

\*Radius 055 only possible with e-chains® Series 2500

Supplement Part No. with required radius. Example: 2500.05D36.100.0

Interior separation for extender crossbars

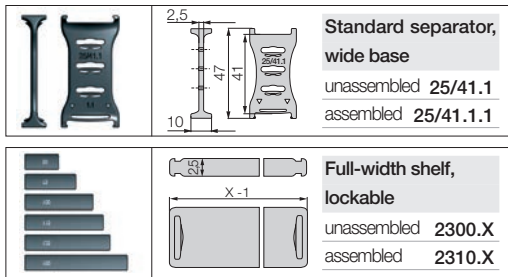

Standard separator, wide base

For maximum locking strength and safe standing. In standard configuration separators are assembled every 2<sup>nd</sup> link.

Horizontal separation

Full-width shelf locks safely into separators on both ends, fixed width possible. Separators can be moved freely over the shelf in horizontal direction. Can be arranged at 3 different heights. **Delivery program ▶ left page**

Separator with integrated strain relief

Strain relief separator Part No. 2020.Z can be integrated into the mounting bracket and can be placed there at any point of the e-chain®. It combines strain relief and interior separation, it can be installed on the first or last chain link and is easy to assemble without any screws. **Further Information ▶ from page 650**



Optional: Support tray tool kit.

For support of the lower run.

Simple one-piece support trays according to your requirements and specification. **The complete range with order options ▶ from page 714**



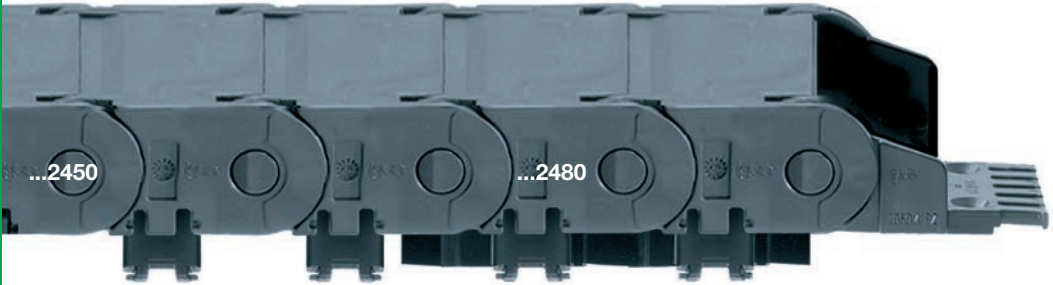

Half e-tubes | Series 2450 snap-open along inner radius, closed along outer radius  
Full e-tubes | Series 2480 snap-open along inner radius, fully enclosed

Half e-tubes snap-open along inner radius	Full e-tubes snap-open along inner radius	 <i>Bi</i> [mm]	<i>Ba</i> [mm]	<i>R</i> Bending radii [mm]	2450 [kg/m]	2480 [kg/m]
2450. 02 .R.0	2480. 02 .R.0	25	41	055*   075   100   125   150   175   200   225   250	≈ 0,80	≈ 0,82
2450. 03 .R.0	2480. 03 .R.0	38	54	055*   075   100   125   150   175   200   225   250	≈ 0,88	≈ 0,92
2450. 05 .R.0	2480. 05 .R.0	57	73	055*   075   100   125   150   175   200   225   250	≈ 0,99	≈ 1,03
2450. 07 .R.0	2480. 07 .R.0	77	93	055*   075   100   125   150   175   200   225   250	≈ 1,12	≈ 1,17
2450. 09 .R.0	2480. 09 .R.0	89	105	055*   075   100   125   150   175   200   225   250	≈ 1,20	≈ 1,26
2450. 10 .R.0	2480. 10 .R.0	103	119	055*   075*   100   125   150   175   200   225   250	≈ 1,27	≈ 1,34
2450. 12 .R.0	2480. 12 .R.0	125	141	055*   075   100   125   150   175   200   225   250	≈ 1,35	≈ 1,43

\*Radius available upon request, please consult igus® for delivery time

Radii 055: the e-tube is not completely enclosed. Please consult igus®

Supplement Part No. with required radius. Example: 2450.03.100.0

### Open e-chains® in a flash with the igus® e-chain® opener

Reduce assembly time from 33 to 2 sec. with the igus® e-chain® Opener. Open a long piece of e-chain® in one go. Part No. 908.254.2400 for Series 2450. For widths *Bi* [mm]: 05, 07, 09

Further information and video ► [www.igus.eu/savetime](http://www.igus.eu/savetime)





## Unsupported applications | Short travels

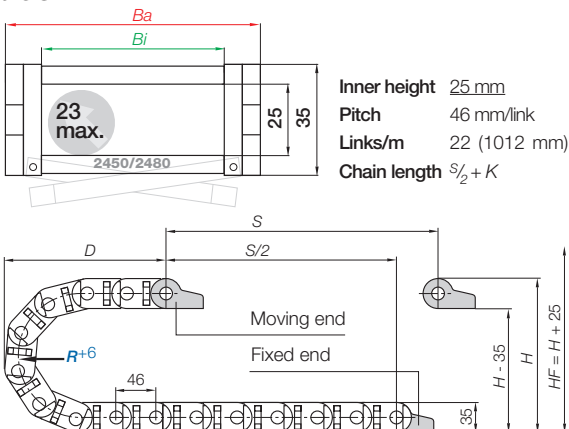
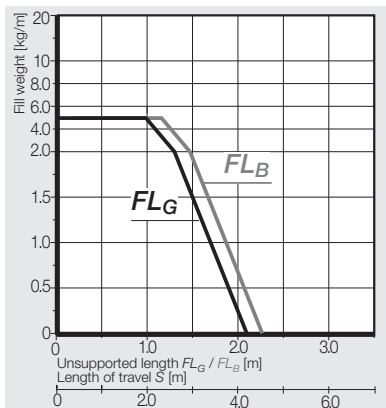

- Inner height 25 mm
- Pitch 46 mm/link
- Links/m 22 (1012 mm)
- Chain length  $\frac{S}{2} + K$

R	055*	075	100	125	150	175	200	225	250
H	145	185	235	285	335	385	435	485	535
D	142	162	187	212	237	262	287	312	337
K	265	330	410	485	565	645	725	800	880

The required clearance height:  $H_F = H + 25$  mm (with 1,5 kg/m fill weight)

\*Radius available upon request, please consult igus\* for delivery time Before using Series 2450/2480 on long travels please consult igus\*.

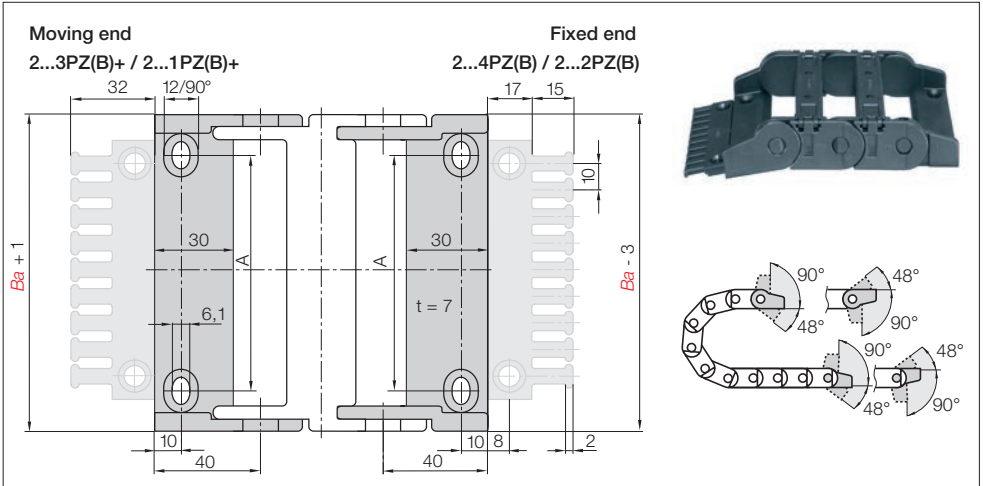

**Polymer pivoting** | Standard | Recommended for unsupported applications

**Polymer locking** | Recommended for vertical hanging and standing applications

Width Index	Standard	Part No. full set <b>pivoting</b> :		Part No. full set <b>locking</b> :		Dim A [mm]	Number of teeth
		with tiewrap plates	without tiewrap plates	with tiewrap plates	without tiewrap plates		
.02.	▶	2020.34PZB+	2020.34PZ+	2020.12PZB+	2020.12PZ+	12	3
.03.	▶	2030.34PZB+	2030.34PZ+	2030.12PZB+	2030.12PZ+	25	4
.05.	▶	2050.34PZB+	2050.34PZ+	2050.12PZB+	2050.12PZ+	44	6
.07.	▶	2070.34PZB+	2070.34PZ+	2070.12PZB+	2070.12PZ+	64	8
.09.	▶	2090.34PZB+	2090.34PZ+	2090.12PZB+	2090.12PZ+	77	9
.10.	▶	2100.34PZB+	2100.34PZ+	2100.12PZB+	2100.12PZ+	90	10
.12.	▶	2125.34PZB+	2125.34PZ+	2125.12PZB+	2125.12PZ+	112	12

Full set with tiewrap plate + 10 cable tiewraps, please add index **K1+** ▶ e.g. 2020.34PZBK1+

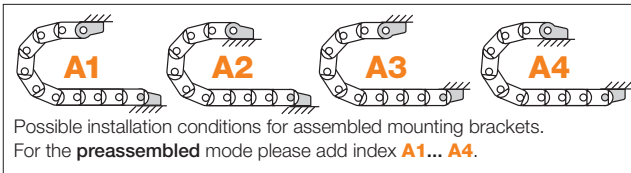

Part No. structure

2020.34 PZB+ **A1**

A... must be indicated on preassembled configurations

With strain relief tiewrap plates

Full set pivoting = 34

Mounting bracket for selected width index



**Strain relief** e.g. clamps, tiewrap plates, nuggets and plug-in clips are available from stock. The complete chainfix range with order options ▶ from page 630

KMA mounting brackets | Attachment on all sides | pivoting | locking

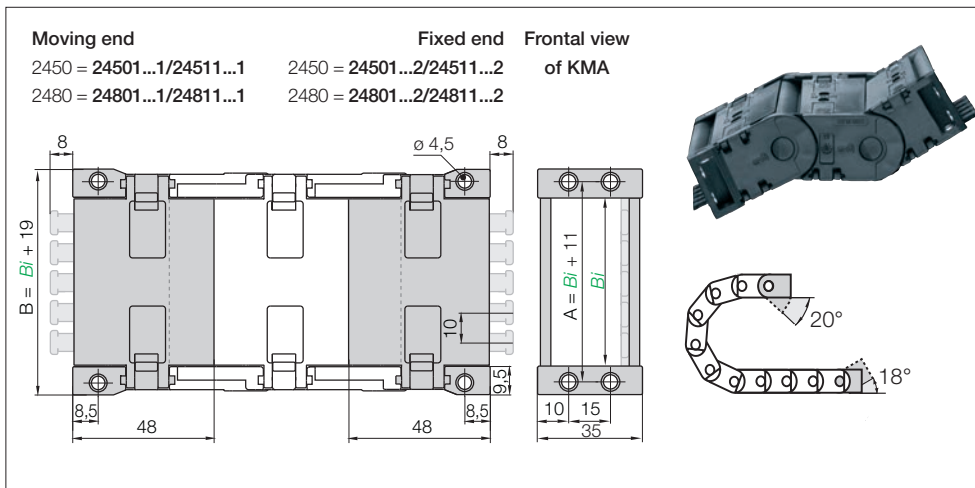

**KMA pivoting** | Recommended for unsupported applications

**KMA locking** | Recommended for vertical hanging and standing applications

Width Index	Part No. full set <b>KMA pivoting:</b>				Part No. full set <b>KMA locking:</b>				Dim A [mm]	Dim A [mm]	Number of teeth
	with tiewrap plates	without tiewrap plates	with tiewrap plates	without tiewrap plates	with tiewrap plates	without tiewrap plates	with tiewrap plates	without tiewrap plates			
.02.	▶ 24501	24801 .02.12ZB	24501	24801 .02.12	24511	24811 .02.12ZB	24511	24811 .02.12	36	44	2
.03.	▶ 24501	24801 .03.12ZB	24501	24801 .03.12	24511	24811 .03.12ZB	24511	24811 .03.12	49	57	4
.05.	▶ 24501	24801 .05.12ZB	24501	24801 .05.12	24511	24811 .05.12ZB	24511	24811 .05.12	68	76	6
.07.	▶ 24501	24801 .07.12ZB	24501	24801 .07.12	24511	24811 .07.12ZB	24511	24811 .07.12	88	86	7
.09.	▶ 24501	24801 .09.12ZB	24501	24801 .09.12	24511	24811 .09.12ZB	24511	24811 .09.12	100	108	9
.10.	▶ 24501	24801 .10.12ZB	24501	24801 .10.12	24511	24811 .10.12ZB	24511	24811 .10.12	114	122	10
.12.	▶ 24501	24801 .12.12ZB	24501	24801 .12.12	24511	24811 .12.12ZB	24511	24811 .12.12	136	144	12

**KMA pivoting:** Part No. 24501... for half e-tube Series 2450 / Part No. 24801... for full e-tube Series 2480

**KMA locking:** Part No. 24511... for half e-tube Series 2450 / Part No. 24811... for full e-tube Series 2480

(KMA = Polymer Metal Mounting Bracket)

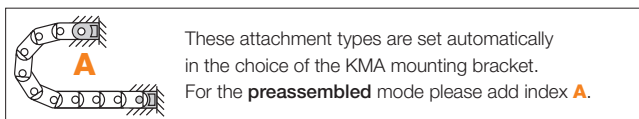

Part No. structure

24501.02.12ZB**A**



Option: Steel **pivoting** Part No. 2000.32 - For e-chains® and e-tubes available

● Pivoting connections ● One part (2-piece) for all e-chain® widths ● Electrically conductive



**Strain relief** e.g. clamps, tiewrap plates, nuggets and plug-in clips are available from stock. The complete chainfix range with order options ▶ from page 630

Interior separation

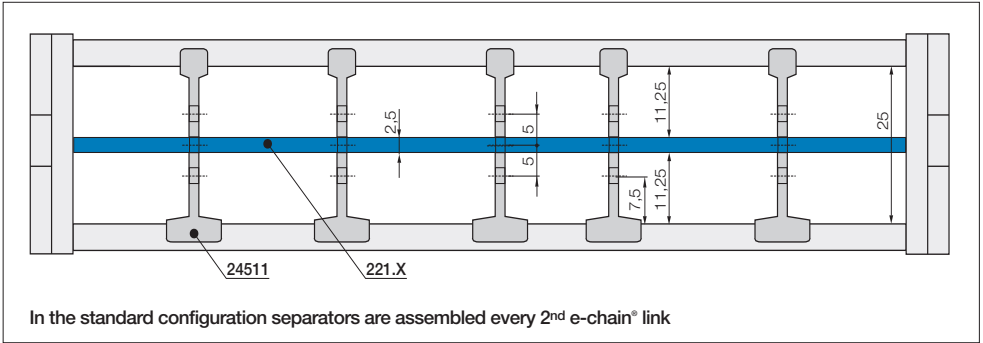

**Slotted separator for e-tubes**

unassembled	<b>24501</b>
assembled	<b>24511</b>

**Slotted separator 24501**

is used when vertical and horizontal separation is required. Due to its slot, it allows basic vertical/horizontal shelving arrangements.

**Full-width shelf for e-tubes**

unassembled	<b>220.X</b>
assembled	<b>221.X</b>

**Full-width shelf 220.X**

This option makes sense in applications with many thin cables with similar diameters. For a consequent subdivision. Full-width shelves can be arranged at 3 different heights (in 5 mm increments).

**Full-width shelves**

Width X [mm]	unassembled	assembled	Width X [mm]	unassembled	assembled	Width X [mm]	unassembled	assembled
025	<b>220.25</b>	<b>221.25</b>	077	<b>220.77</b>	<b>221.77</b>	125	<b>220.125</b>	<b>221.125</b>
038	<b>220.38</b>	<b>221.38</b>	090	<b>220.90</b>	<b>221.90</b>			
057	<b>220.57</b>	<b>221.57</b>	103	<b>220.103</b>	<b>221.103</b>			

Extender crossbars

Extender crossbars only for Series 2450 - Enormous increase of the interior for the smooth guiding of larger hoses. Suitable for hoses with an outer diameter of max. 36 mm.

Extender crossbars for half e-tubes snap-open along inner radius	<i>Bi</i> [mm]	<i>Ba</i> [mm]	<i>R</i> Bending radii [mm]
2450.05 D36.R.0	57	73	075  100  125  150  175  200  225  250
2450.10 D36.R.0	103	119	075  100  125  150  175  200  225  250

Supplement Part No. with required radius. Example: 2450.05D36.100.0

Interior separation for extender crossbars

**Standard separator, wide base**  
unassembled 25/41.1  
assembled 25/41.1.1

**Full-width shelf, lockable**  
unassembled 2300.X  
assembled 2310.X

Standard separator, wide base

For maximum locking strength and safe standing. In standard configuration separators are assembled every 2<sup>nd</sup> link.

Horizontal separation

Full-width shelf locks safely into separators on both ends, fixed width possible. Separators can be moved freely over the shelf in horizontal direction. Can be arranged at 3 different heights.

Separator with integrated strain relief

Strain relief separator Part No. 2020.ZR can be integrated into the mounting bracket and can be placed there at any point of the e-chain®. It combines strain relief and interior separation, it can be installed on the first or last chain link and is easy to assemble without any screws. **Further Information ► from page 650**



Optional: Support tray tool kit.

For support of the lower run.

Simple one-piece support trays according to your requirements and specification. The complete range with order options ► from page 714





Optimal height, high stability

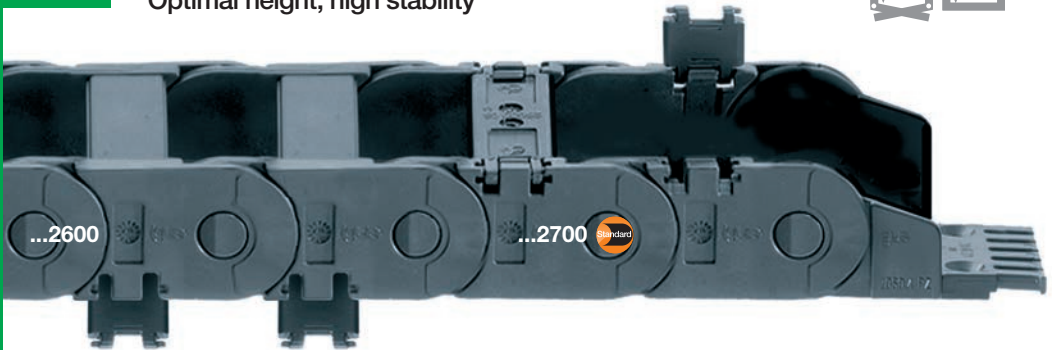

e-chains® | Series 2600 snap-open along inner radius

e-chains® | Series 2700 snap-open along outer radius

e-chains® snap-open along inner radius	e-chains® snap-open along outer radius	 <i>Bi</i> [mm]	<i>Ba</i> [mm]	<i>R</i> Bending radii [mm]											2600 [kg/m]	2700 [kg/m]				
2600.05 .R.0	2700.05 .R.0	50	66	063   075   100   125   150   175   200   250															≈ 1,17	≈ 1,17
2600.06 .R.0	2700.06 .R.0	65	81	063   075   100   125   150   175   200   250															≈ 1,24	≈ 1,24
2600.07 .R.0	2700.07 .R.0	75	91	063   075   100   125   150   175   200   250															≈ 1,30	≈ 1,30
2600.09 .R.0	2700.09 .R.0	90	106	063   075   100   125   150   175   200   250															≈ 1,37	≈ 1,37
2600.10 .R.0	2700.10 .R.0	100	116	063   075   100   125   150   175   200   250															≈ 1,39	≈ 1,39
2600.12 .R.0	2700.12 .R.0	125	141	063   075   100   125   150   175   200   250															≈ 1,48	≈ 1,48
2600.15 .R.0	2700.15 .R.0	150	166	063   075   100   125   150   175   200   250															≈ 1,62	≈ 1,62
2600.17 .R.0	2700.17 .R.0	175	194	063   075   100   125   150   175   200   250															≈ 1,85	≈ 1,85

Half e-tubes, Series 2650 and full e-tubes Series 2680 ► from page 276

Supplement Part No. with required radius. Example: 2700.05.100.0



ESD/ATEX permanently conductive e-chains® - 2700 several widths with delivery from stock:  
Inner widths *Bi* 50 - 125, radii *R* 063 - 150. Full ESD delivery program ► [www.igus.eu/eu/ESD](http://www.igus.eu/eu/ESD)

### Open e-chains® in a flash with the igus® e-chain® opener

Reduce assembly time from 33 to 2 sec. with the igus® e-chain® Opener. Open a long piece of e-chain® in one go. Part No. 908.254.2600 for Series 2600/2700.  
For widths *Bi* [mm]: 06, 07, 09, 10

Further information and video ► [www.igus.eu/savetime](http://www.igus.eu/savetime)







Unsupported applications | Short travels

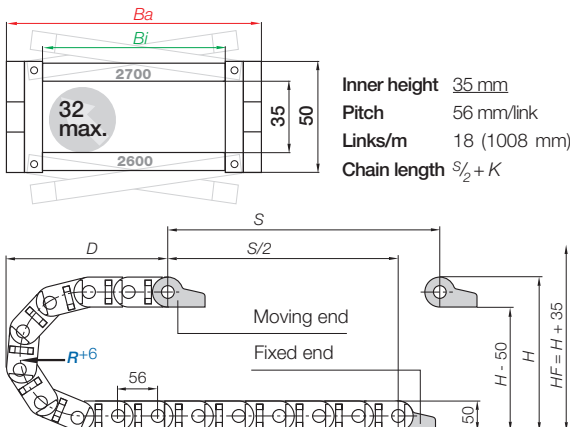
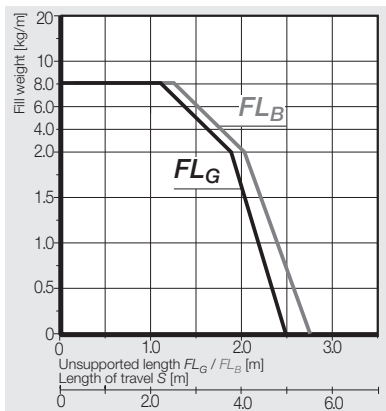

R	063	075	100	125	150	175	200	250
H	176	200	250	300	350	400	450	550
D	172	184	209	234	259	284	309	359
K	310	350	430	505	585	665	745	900

The required clearance height:  $H_F = H + 35$  mm (with 2,0 kg/m fill weight)

Before using Series 2600 on long travels please consult igus®.

Gliding applications | Long travels from 10 m to max. 120 m

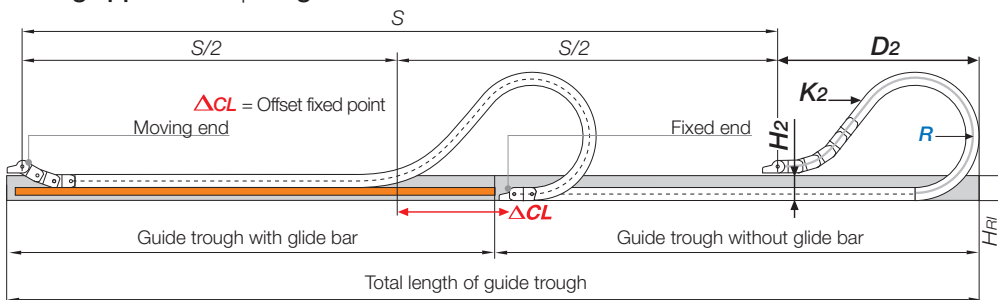

**Note:** For using Series 2600 for long travels (gliding), please consult with igus® first.

For long travels, igus® specifies **Series 2700** that snaps open along the outer radius.

In case of travels between 5 and 10 m we recommend a longer unsupported length. **Chain length**  $S/2 + K_2$

R	063	075	100	125	150	175	200	250
H <sub>2</sub>	130	150	166	166	166	166	166	166
D <sub>2</sub> <sup>+25</sup>	140	150	350	475	500	655	770	950
K <sub>2</sub>	335	375	616	784	896	1120	1288	1624
ΔCL	-	-	144	244	244	374	464	594

Before using Series 2600 on long travels please consult igus®.

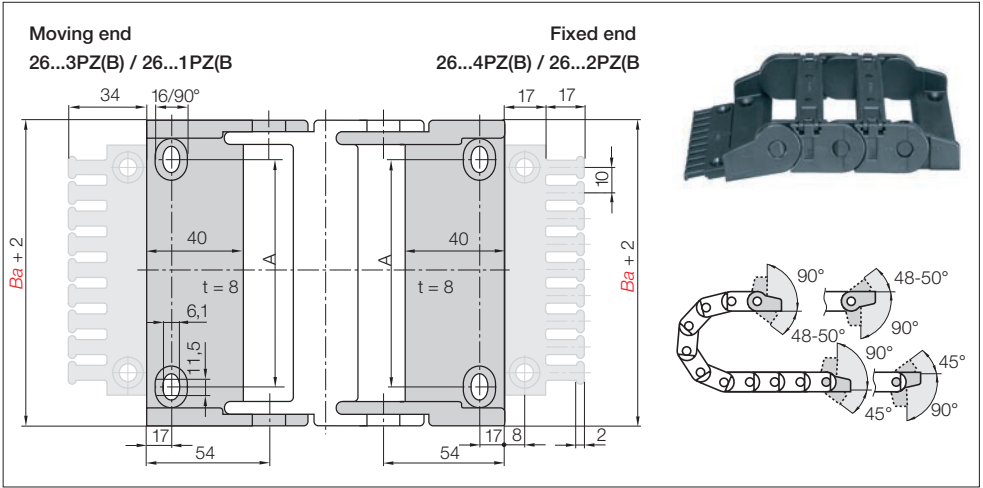

**Polymer pivoting** | Standard | Recommended for unsupported and gliding applications  
**Polymer locking** | Recommended for vertical hanging and standing applications

Width Index	Standard	Part No. full set <b>pivoting</b> :		Part No. full set <b>locking</b> :		Dim A [mm]	Number of teeth
		with tiewrap plates	without tiewrap plates	with tiewrap plates	without tiewrap plates		
.05.	▶	2605.34PZB	2605.34PZ	2605.12PZB	2605.12PZ	30	5
.06.	▶	2606.34PZB	2606.34PZ	2606.12PZB	2606.12PZ	45	5
.07.	▶	2607.34PZB	2607.34PZ	2607.12PZB	2607.12PZ	55	7
.09.	▶	2609.34PZB	2609.34PZ	2609.12PZB	2609.12PZ	70	9
.10.	▶	2610.34PZB	2610.34PZ	2610.12PZB	2610.12PZ	80	10
.12.	▶	2612.34PZB	2612.34PZ	2612.12PZB	2612.12PZ	105	12
.15.	▶	2615.34PZB	2615.34PZ	2615.12PZB	2615.12PZ	130	15
.17.	▶	2617.34PZB	2617.34PZ	2617.12PZB	2617.12PZ	155	17

Full set with tiewrap plate + 10 cable tiewraps, please add index **K1** ▶ e.g. 2605.34PZBK1

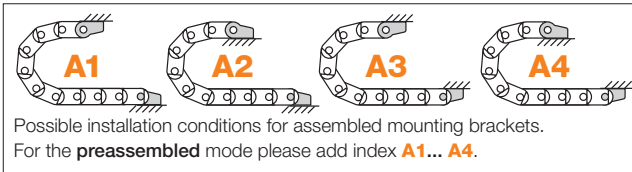

Part No. structure

2605. 34 PZB **A1**

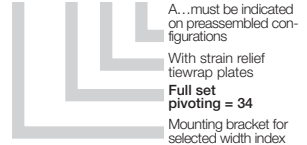

**Strain relief** e.g. clamps, tiewrap plates, nuggets and plug-in clips are available from stock. The complete chainfix range with order options ▶ from page 630

KMA mounting brackets | Attachment on all sides | pivoting | locking

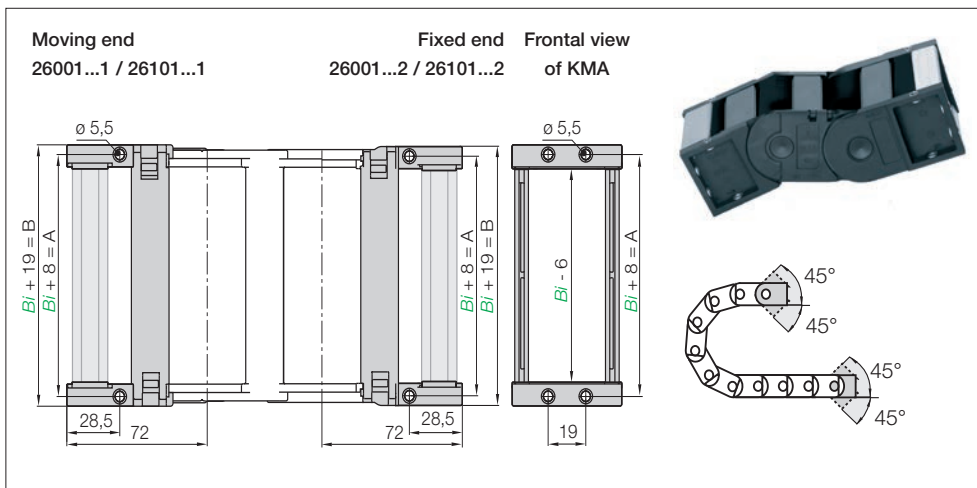

**KMA pivoting** | Recommended for unsupported and gliding applications

**KMA locking** | Recommended for vertical hanging and standing applications

Width Index	Part No. full set <b>KMA pivoting:</b>		Part No. full set <b>KMA locking:</b>		Dim A [mm]	Dim B [mm]
	with C-profile	without C-profile	with C-profile	without C-profile		
.05.	▶ 26001.05.12.C	26001.05.12	26101.05.12.C	26101.05.12	58	69
.06.	▶ 26001.06.12.C	26001.06.12	26101.06.12.C	26101.06.12	73	84
.07.	▶ 26001.07.12.C	26001.07.12	26101.07.12.C	26101.07.12	83	94
.09.	▶ 26001.09.12.C	26001.09.12	26101.09.12.C	26101.09.12	98	109
.10.	▶ 26001.10.12.C	26001.10.12	26101.10.12.C	26101.10.12	108	119
.12.	▶ 26001.12.12.C	26001.12.12	26101.12.12.C	26101.12.12	133	144
.15.	▶ 26001.15.12.C	26001.15.12	26101.15.12.C	26101.15.12	158	169
.17.	▶ 26001.17.12.C	26001.17.12	26101.17.12.C	26101.17.12	183	194

KMA pivoting to one side: **Moving end 26101...3 / Fixed end 26101...4**

(KMA = Polymer Metal Mounting Bracket)

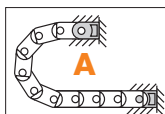

These attachment types are set automatically in the choice of the KMA mounting bracket. For the **preassembled** mode please add index **A**.

Part No. structure

**26001. 05. 12.C A**



Option: **Steel locking** Part No. 260.12 - For e-chains® and e-tubes available

● Locked connections ● One part (2-piece) for all e-chain® widths ● Electrically conductive

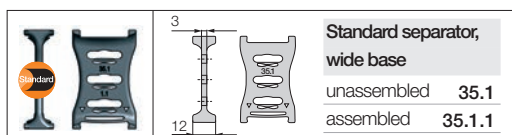
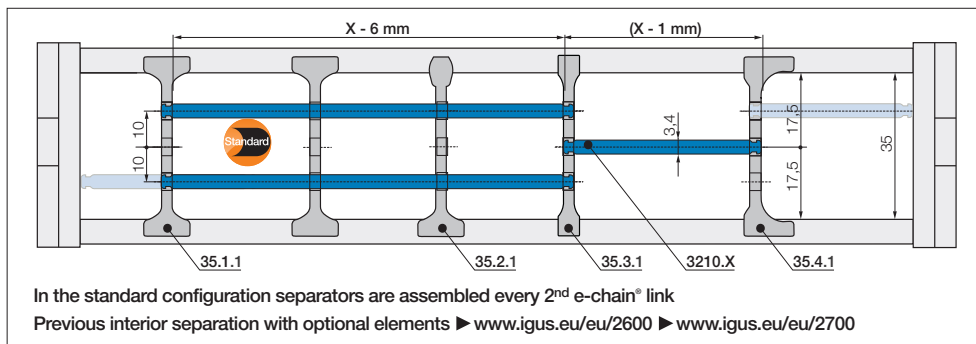

**Strain relief** e.g. clamps, tiwrap plates, nuggets and plug-in clips are available from stock. The complete chainfix range with order options ▶ from page 630

**Standard - for all applications**

Separator with a wide base for maximum locking strength and safe standing in e-chains®.

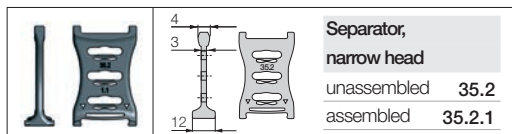
**For even faster installation**

Firm hold to one side with a wide base, narrow on opposed side for easy cable assembly (slight grip).

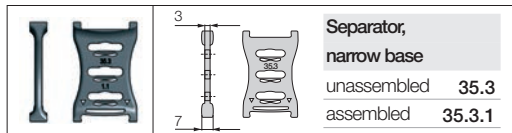
**For many thin cables**

Separator with a narrow base for a large number of thin cables side by side. Saves space in e-chains®.

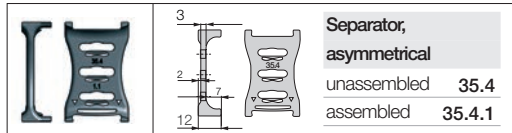
**For side-mounted applications**

Asymmetrical separator, for defined distance. No additional spacers necessary.

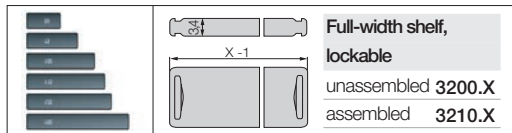
**Horizontal separation**

Full-width shelf locks safely into separators on both ends, fixed width possible. To be used as full-width shelf for a consequent subdivision or as shelf for a pattern system in 3 levels.

**Lockable full-width shelves - for the standard interior separation**

Width X [mm]	unassembled	assembled	Width X [mm]	unassembled	assembled	Width X [mm]	unassembled	assembled
050	3200.050	3210.050	115	3200.115	3210.115	175	3200.175	3210.175
075	3200.075	3210.075	125	3200.125	3210.125			
100	3200.100	3210.100	150	3200.150	3210.150			



Extender crossbars

Extender crossbars - Enormous increase of the interior for the smooth guiding of larger hoses.  
Suitable for hoses with an outer diameter of max. 58 mm.

Extender crossbars for e-chains® snap-open along inner radius	Extender crossbars for e-chains® snap-open along outer radius	<i>Bi</i> [mm]	<i>Ba</i> [mm]	<i>R</i> Bending radii [mm]
2600.07 D58.R.0	2700.07 D58.R.0	75	91	063* 075* 100 125 150 175 200 250
2600.15 D58.R.0	2700.15 D58.R.0	150	166	063* 075* 100 125 150 175 200 250

\*Radius 055 only possible with e-chains® Series 2700

Supplement Part No. with required radius. Example: 2700.15D58.100.0

Interior separation for extender crossbars

**Standard separator, wide base**  
unassembled 35/62.1  
assembled 35/62.1.1

**Full-width shelf, lockable**  
unassembled 3200.X  
assembled 3210.X

Standard separator, wide base

For maximum locking strength and safe standing. In standard configuration separators are assembled every 2<sup>nd</sup> link.

Horizontal separation

Full-width shelf locks safely into separators on both ends, fixed width possible. Separators can be moved freely over the shelf in horizontal direction. Can be arranged at 5 different heights.

Separator with integrated strain relief

Strain relief separator Part No. 262.Z can be integrated into the mounting bracket and can be placed there at any point of the e-chain®. It combines strain relief and interior separation, it can be installed on the first or last chain link and is easy to assemble without any screws. **Further Information ▶ from page 650**



Optional: Support tray tool kit.

For support of the lower run.

Simple one-piece support trays according to your requirements and specification.

The complete range with order options ▶ from page 714





Half e-tubes | Series 2650 snap-open along inner radius, closed along outer radius

Full e-tubes | Series 2680 snap-open along inner radius, fully enclosed

Half e-tubes snap-open along inner radius	Full e-tubes snap-open along inner radius	 <i>Bi</i> [mm]	<i>Ba</i> [mm]	<i>R</i> Bending radii [mm]	2650 [kg/m]	2680 [kg/m]
2650.05 .R.0	2680.05 .R.0	50	66	063* 075* 100 125 150 175 200 250	≈ 1,25	≈ 1,33
2650.06 .R.0	2680.06 .R.0	65	81	063* 075* 100 125 150 175 200 250	≈ 1,36	≈ 1,43
2650.07 .R.0	2680.07 .R.0	75	91	063* 075* 100 125 150 175 200 250	≈ 1,40	≈ 1,51
2650.09 .R.0	2680.09 .R.0	90	106	063* 075* 100 125 150 175 200 250	≈ 1,55	≈ 1,62
2650.10 .R.0	2680.10 .R.0	100	116	063* 075* 100 125 150 175 200 250	≈ 1,61	≈ 1,81
2650.12 .R.0	2680.12 .R.0	125	141	063* 075* 100 125 150 175 200 250	≈ 1,70	≈ 1,99
2650.15 .R.0	2680.15 .R.0	150	166	063* 075* 100 125 150 175 200 250	≈ 1,80	≈ 2,17
2650.17 .R.0	2680.17 .R.0	175	194	063* 075* 100 125 150 175 200 250	≈ 2,00	≈ 2,35

\*Radius available upon request, please consult igus\* for delivery time

Radii 063, 075: the e-tube is not completely enclosed. Please consult igus\*

Supplement Part No. with required radius. Example: 2650.05.100.0

### Open e-chains® in a flash with the igus® e-chain® opener

Reduce assembly time from 33 to 2 sec. with the igus® e-chain® Opener. Open a long piece of e-chain® in one go. Part No. 908.254.2600 for Series 2650. For widths *Bi* [mm]: 06, 07, 09, 10

Further information and video ► [www.igus.eu/savetime](http://www.igus.eu/savetime)





## Unsupported applications | Short travels

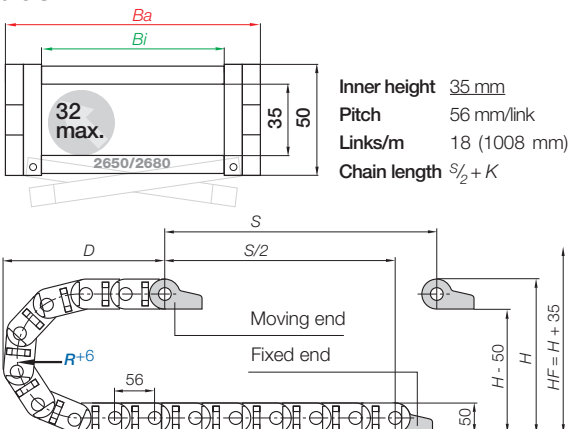
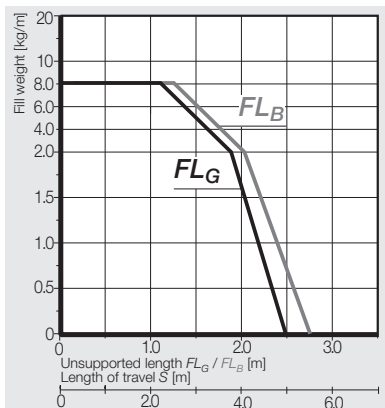

**Inner height** 35 mm  
**Pitch** 56 mm/link  
**Links/m** 18 (1008 mm)  
**Chain length**  $S/2 + K$

R	063*	075*	100	125	150	175	200	250
H	176	200	250	300	350	400	450	550
D	172	184	209	234	259	284	309	359
K	310	350	430	505	585	665	745	900

The required clearance height:  $H_F = H + 35$  mm (with 2,0 kg/m fill weight)

\*Radius available upon request, please consult igus\* for delivery time Before using Series 2650/2680 on long travels please consult igus\*.

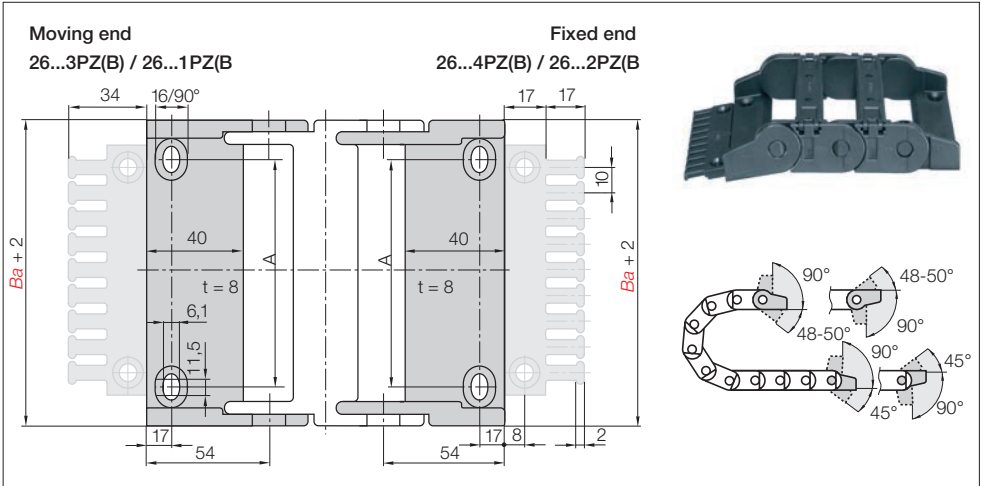

**Polymer pivoting | Standard | Recommended for unsupported applications**

**Polymer locking | Recommended for vertical hanging and standing applications**

Width Index	Standard	Part No. full set <b>pivoting</b> :		Part No. full set <b>locking</b> :		Dim A [mm]	Number of teeth
		with tiewrap plates	without tiewrap plates	with tiewrap plates	without tiewrap plates		
.05.	▶	2605.34PZB	2605.34PZ	2605.12PZB	2605.12PZ	30	5
.06.	▶	2606.34PZB	2606.34PZ	2606.12PZB	2606.12PZ	45	5
.07.	▶	2607.34PZB	2607.34PZ	2607.12PZB	2607.12PZ	55	7
.09.	▶	2609.34PZB	2609.34PZ	2609.12PZB	2609.12PZ	70	9
.10.	▶	2610.34PZB	2610.34PZ	2610.12PZB	2610.12PZ	80	10
.12.	▶	2612.34PZB	2612.34PZ	2612.12PZB	2612.12PZ	105	12
.15.	▶	2615.34PZB	2615.34PZ	2615.12PZB	2615.12PZ	130	15
.17.	▶	2617.34PZB	2617.34PZ	2617.12PZB	2617.12PZ	155	17

Full set with tiewrap plate + 10 cable tiewraps, please add index **K1** ▶ e.g. 2605.34PZBK1

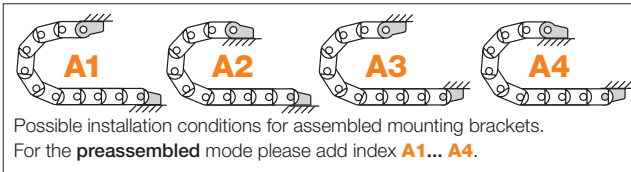

**Part No. structure**

**2605. 34 PZB A1**

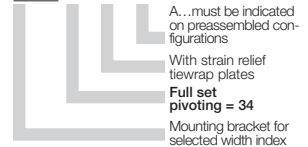

**Strain relief** e.g. clamps, tiewrap plates, nuggets and plug-in clips are available from stock. The complete chainfix range with order options ▶ from page 630



KMA mounting brackets | Attachment on all sides | pivoting | locking

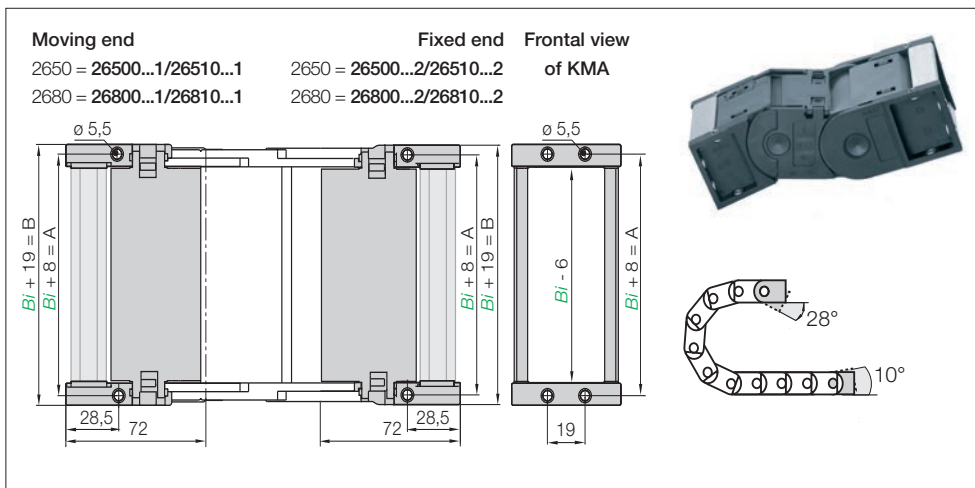

**KMA pivoting** | Recommended for unsupported applications

**KMA locking** | Recommended for vertical hanging and standing applications

Width Index	Part No. full set <b>KMA pivoting:</b>				Part No. full set <b>KMA locking:</b>				Dim A [mm]	Dim A [mm]
	with C-profile		without C-profile		with C-profile		without C-profile			
.05.	▶ 26500	▶ 26800.05.12.C	▶ 26500	▶ 26800.05.12	▶ 26510	▶ 26810.05.12.C	▶ 26510	▶ 26810.05.12	58	69
.06.	▶ 26500	▶ 26800.06.12.C	▶ 26500	▶ 26800.06.12	▶ 26510	▶ 26810.06.12.C	▶ 26510	▶ 26810.06.12	73	84
.07.	▶ 26500	▶ 26800.07.12.C	▶ 26500	▶ 26800.07.12	▶ 26510	▶ 26810.07.12.C	▶ 26510	▶ 26810.07.12	83	94
.09.	▶ 26500	▶ 26800.09.12.C	▶ 26500	▶ 26800.09.12	▶ 26510	▶ 26810.09.12.C	▶ 26510	▶ 26810.09.12	98	109
.10.	▶ 26500	▶ 26800.10.12.C	▶ 26500	▶ 26800.10.12	▶ 26510	▶ 26810.10.12.C	▶ 26510	▶ 26810.10.12	108	119
.12.	▶ 26500	▶ 26800.12.12.C	▶ 26500	▶ 26800.12.12	▶ 26510	▶ 26810.12.12.C	▶ 26510	▶ 26810.12.12	133	144
.15.	▶ 26500	▶ 26800.15.12.C	▶ 26500	▶ 26800.15.12	▶ 26510	▶ 26810.15.12.C	▶ 26510	▶ 26810.15.12	158	169
.17.	▶ 26500	▶ 26800.17.12.C	▶ 26500	▶ 26800.17.12	▶ 26510	▶ 26810.17.12.C	▶ 26510	▶ 26810.17.12	183	194

**KMA pivoting:** Part No. 26500... for half e-tube Series 2650 / Part No. 26800... for full e-tube Series 2680

**KMA locking:** Part No. 26510... for half e-tube Series 2650 / Part No. 26810... for full e-tube Series 2680

(KMA = Polymer Metal Mounting Bracket)

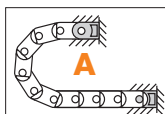

These attachment types are set automatically in the choice of the KMA mounting bracket. For the **preassembled** mode please add index **A**.

**Part No. structure**

**26500.05.12.C A**



**Option: Steel locking Part No. 260.12 - For e-chains® and e-tubes available**

● Locked connections ● One part (2-piece) for all e-chain® widths ● Electrically conductive



**Strain relief** e.g. clamps, tiwrap plates, nuggets and plug-in clips are available from stock. The complete chainfix range with order options ▶ from page 630

Interior separation

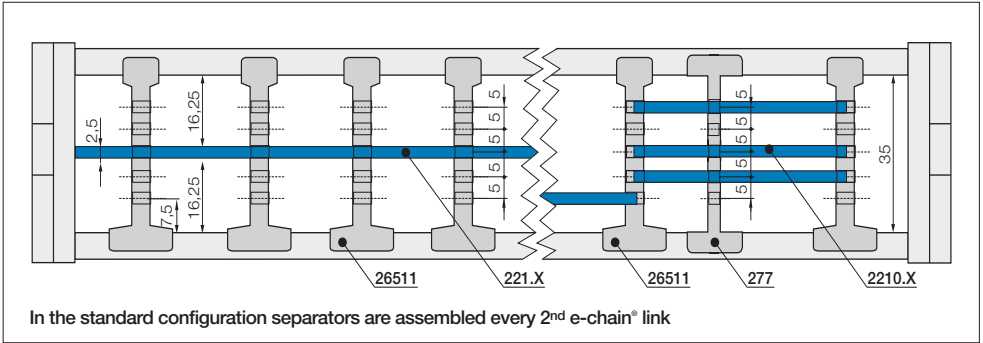

**Slotted separator for e-tubes**  
 unassembled **26501**  
 assembled **26511**

**Slotted separator 26501**

is used when vertical and horizontal separation is required. Due to its slot, it allows basic vertical/horizontal shelving arrangements.

**Full-width shelf for e-tubes**  
 unassembled **220.X**  
 assembled **221.X**

**Full-width shelf 220.X**

This option makes sense in applications with many thin cables with similar diameters. For a consequent subdivision. Full-width shelves can be arranged at 5 different heights (in 5 mm increments).

**Full-width shelves**

Width X [mm]	unassembled	assembled	Width X [mm]	unassembled	assembled	Width X [mm]	unassembled	assembled
050	220.50	221.50	090	220.90	221.90	150	220.150	221.150
065	220.65	221.65	100	220.100	221.100	175	220.175	221.175
075	220.75	221.75	125	220.125	221.125			

**Open slotted separator for e-tubes**  
 unassembled **276**  
 assembled **277**

**Open slotted separator 276**

Quick assembly - retrofitting into an existing interior separation system without dismantling.

**Shelf for e-tubes**  
 unassembled **2200.X**  
 assembled **2210.X**

**Shelf 2200.X**

For applications involving many cables with different diameters, shelves can be arranged at alternate heights. They can be arranged at 5 different heights (in 5 mm increments).

**Shelves**

Width X [mm]	unassembled	assembled	Width X [mm]	unassembled	assembled	Width X [mm]	unassembled	assembled
018	2200.18	2210.18	043	2200.43	2210.43	088	2200.88	2210.88
023	2200.23	2210.23	048	2200.48	2210.48	099	2200.99	2210.99
028	2200.28	2210.28	058	2200.58	2210.58	124	2200.124	2210.124
033	2200.33	2210.33	068	2200.68	2210.68	149	2200.149	2210.149
038	2200.38	2210.38	073	2200.73	2210.73			

Extender crossbars

Extender crossbars only for Series 2650 - Enormous increase of the interior for the smooth guiding of larger hoses. Suitable for hoses with an outer diameter of max. 58 mm.

Extender crossbars for half e-tubes snap-open along inner radius	<i>Bi</i> [mm]	<i>Ba</i> [mm]	<i>R</i> Bending radii [mm]					
2650.07 D58.R.0	75	91	100	125	150	175	200	250
2650.15 D58.R.0	150	166	100	125	150	175	200	250

Supplement Part No. with required radius. Example: 2650.15D58.100.0

Interior separation for extender crossbars

**Standard separator, wide base**  
unassembled 35/62.1  
assembled 35/62.1.1

**Full-width shelf, lockable**  
unassembled 3200.X  
assembled 3210.X

Standard separator, wide base

For maximum locking strength and safe standing. In standard configuration separators are assembled every 2<sup>nd</sup> link.

Horizontal separation

Full-width shelf locks safely into separators on both ends, fixed width possible. Separators can be moved freely over the shelf in horizontal direction. Can be arranged at 5 different heights.

**Optional: Support tray tool kit.**  
For support of the lower run.

Simple one-piece support trays according to your requirements and specification.  
The complete range with order options ► from page 714

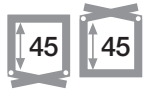

Large inner height, high stability

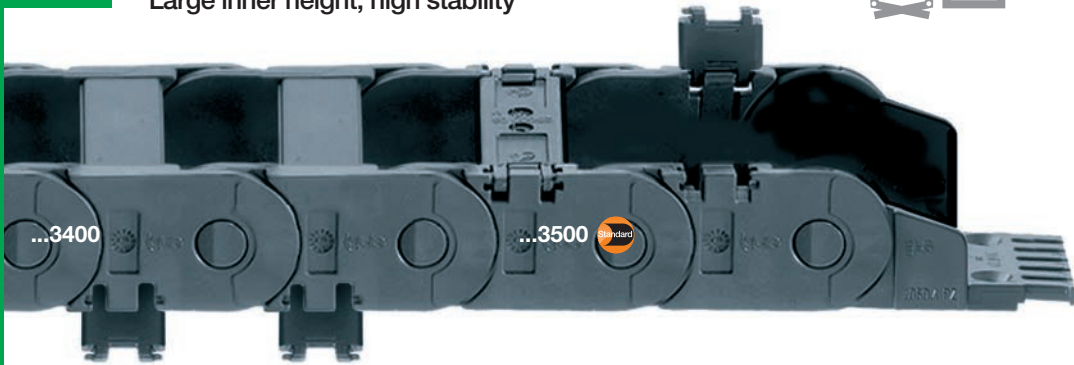

e-chains® | Series 3400 snap-open along inner radius

e-chains® | Series 3500 snap-open along outer radius

e-chains® snap-open along inner radius	e-chains® snap-open along outer radius		<i>Bi</i> [mm]	<i>Ba</i> [mm]	<i>R</i> Bending radii [mm]										3400 [kg/m]	3500 [kg/m]
3400.050. <i>R.0</i>	3500.050. <i>R.0</i>		50	70	075	100	125	150	200	250	300		≈ 1,60	≈ 1,60		
3400.075. <i>R.0</i>	3500.075. <i>R.0</i>		75	95	075	100	125	150	200	250	300		≈ 1,78	≈ 1,78		
3400.100. <i>R.0</i>	3500.100. <i>R.0</i>		100	120	075	100	125	150	200	250	300		≈ 1,93	≈ 1,93		
3400.115. <i>R.0</i>	3500.115. <i>R.0</i>		115	135	075	100	125	150	200	250	300		≈ 1,99	≈ 1,99		
3400.125. <i>R.0</i>	3500.125. <i>R.0</i>		125	145	075	100	125	150	200	250	300		≈ 2,03	≈ 2,03		
3400.150. <i>R.0</i>	3500.150. <i>R.0</i>		150	170	075	100	125	150	200	250	300		≈ 2,17	≈ 2,17		
3400.175. <i>R.0</i>	3500.175. <i>R.0</i>		175	195	075	100	125	150	200	250	300		≈ 2,28	≈ 2,28		
3400.200. <i>R.0</i>	3500.200. <i>R.0</i>		200	220	075	100	125	150	200	250	300		≈ 2,45	≈ 2,45		
3400.225. <i>R.0</i>	3500.225. <i>R.0</i>		225	245	075	100	125	150	200	250	300		≈ 2,59	≈ 2,59		
3400.250. <i>R.0</i>	3500.250. <i>R.0</i>		250	270	075	100	125	150	200	250	300		≈ 2,73	≈ 2,73		

Half e-tubes, Series 3450 and full e-tubes Series 3480 ► from page 288

Supplement Part No. with required radius. Example: 3500.075.200.0

## Open e-chains® in a flash with the igus® e-chain® opener

Reduce assembly time from 33 to 2 sec. with the igus® e-chain® Opener. Open a long piece of e-chain® in one go. Part No. 908.254.3400 for Series 3400/3500. For widths *Bi* [mm]: 050, 075, 100, 115.

Further information and video ► [www.igus.eu/eu/savetime](http://www.igus.eu/eu/savetime)



Unsupported applications | Short travels

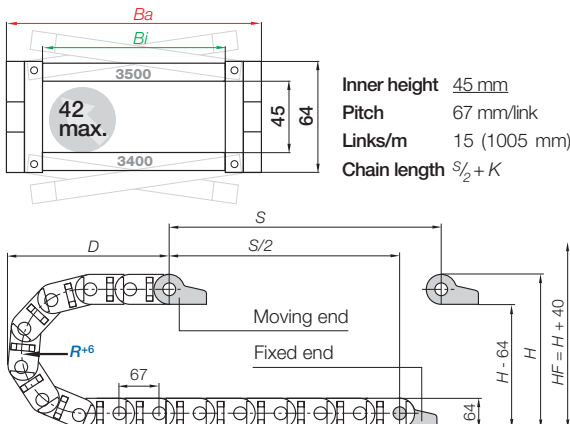
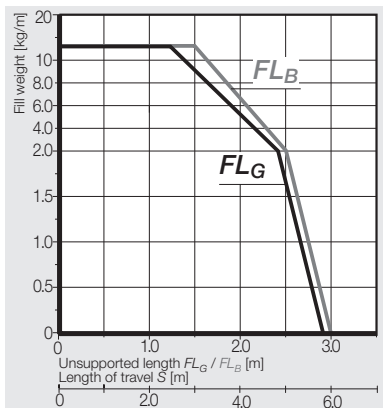

Inner height 45 mm  
Pitch 67 mm/link  
Links/m 15 (1005 mm)  
Chain length  $\frac{S}{2} + K$

R	075	100	125	150	200	250	300
H	214	264	314	364	464	564	664
D	208	233	258	283	333	383	433
K	370	450	530	610	765	920	1080

The required clearance height:  $H_F = H + 40$  mm (with 2,5 kg/m fill weight)

Before using Series 3400 on long travels please consult igus®.

Gliding applications | Long travels from 10 m to max. 150 m

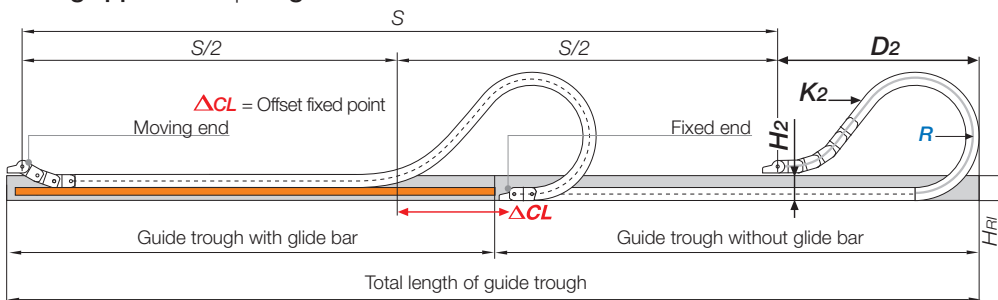

**Note:** For using Series 3400 for long travels (gliding), please consult with igus® first.

For long travels, igus® specifies **Series 3500** that snaps open along the outer radius.

In case of travels between 6 and 10 m we recommend a longer unsupported length. **Chain length**  $\frac{S}{2} + K_2$

R	075	100	125	150	200	250	300
H <sub>2</sub>	150	200	186	186	186	186	186
D <sub>2</sub> <sup>+25</sup>	208	233	475	570	780	1010	1150
K <sub>2</sub>	370	450	804	1005	1340	1675	1943
ΔCL	-	-	233	303	463	643	733

Before using Series 3400 on long travels please consult igus®.

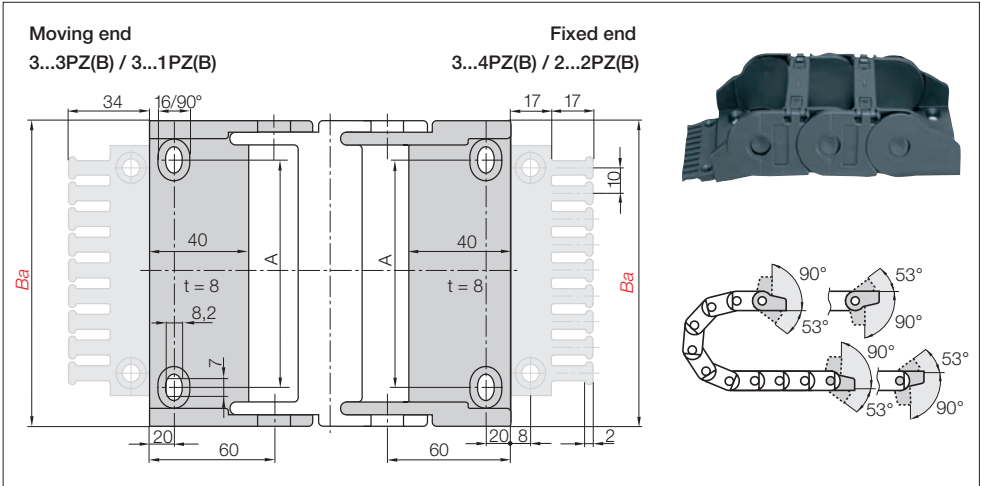

**Polymer pivoting** | Standard | Recommended for unsupported and gliding applications  
**Polymer locking** | Recommended for vertical hanging and standing applications

Width Index	Standard	Part No. full set <b>pivoting</b> :		Part No. full set <b>locking</b> :		Dim A [mm]	Number of teeth
		with tiewrap plates	without tiewrap plates	with tiewrap plates	without tiewrap plates		
.050.	▶	3050.34PZB	3050.34PZ	3050.12PZB	3050.12PZ	28	5
.075.	▶	3075.34PZB	3075.34PZ	3075.12PZB	3075.12PZ	53	7
.100.	▶	3100.34PZB	3100.34PZ	3100.12PZB	3100.12PZ	78	10
.115.	▶	3115.34PZB	3115.34PZ	3115.12PZB	3115.12PZ	93	11
.125.	▶	3125.34PZB	3125.34PZ	3125.12PZB	3125.12PZ	103	12
.150.	▶	3150.34PZB	3150.34PZ	3150.12PZB	3150.12PZ	128	15
.175.	▶	3175.34PZB	3175.34PZ	3175.12PZB	3175.12PZ	153	17
.200.	▶	3200.34PZB	3200.34PZ	3200.12PZB	3200.12PZ	178	20
.225.	▶	3225.34PZB	3225.34PZ	3225.12PZB	3225.12PZ	203	22
.250.	▶	3250.34PZB	3250.34PZ	3250.12PZB	3250.12PZ	228	25

Full set with tiewrap plate + 10 cable tiewraps, please add index **K1** ▶ e.g. **3250.34PZBK1**

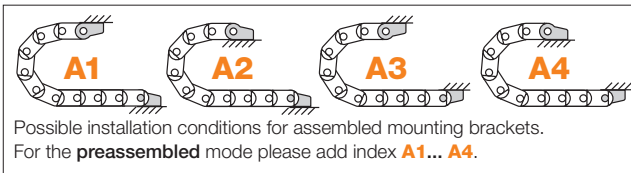

### Part No. structure

**3075. 34 PZB A1**

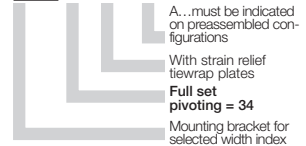

**Strain relief** e.g. clamps, tiewrap plates, nuggets and plug-in clips are available from stock. The complete chainfix range with order options ▶ from page 630

KMA mounting brackets | Attachment on all sides | pivoting | locking

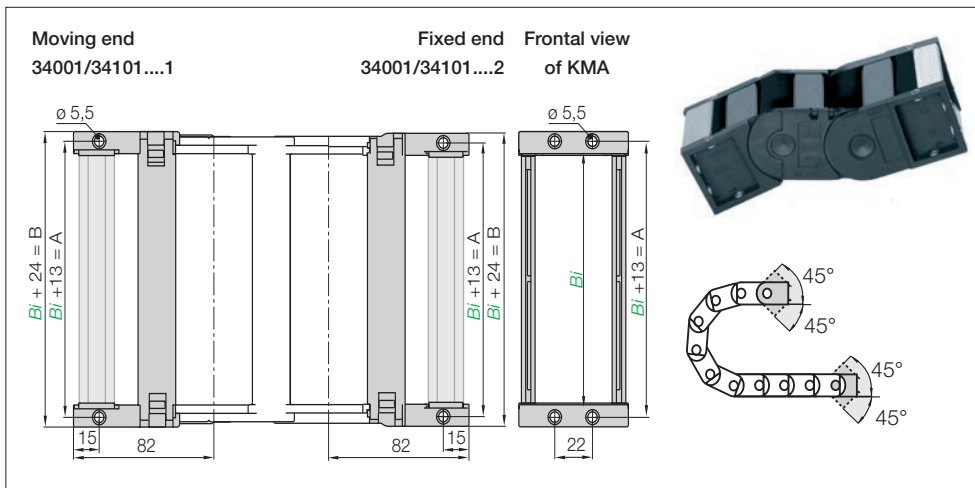

**KMA pivoting** | Recommended for unsupported and gliding applications

**KMA locking** | Recommended for vertical hanging and standing applications

Width Index	Part No. full set <b>KMA pivoting:</b>		Part No. full set <b>KMA locking:</b>		Dim A [mm]	Dim B [mm]
	with C-profile	without C-profile	with C-profile	without C-profile		
.050. ▶	34001.050.12.C	34001.050.12	34101.050.12.C	34101.050.12	63	74
.075. ▶	34001.075.12.C	34001.075.12	34101.075.12.C	34101.075.12	88	99
.100. ▶	34001.100.12.C	34001.100.12	34101.100.12.C	34101.100.12	113	124
.115. ▶	34001.115.12.C	34001.115.12	34101.115.12.C	34101.115.12	128	139
.125. ▶	34001.125.12.C	34001.125.12	34101.125.12.C	34101.125.12	138	149
.150. ▶	34001.150.12.C	34001.150.12	34101.150.12.C	34101.150.12	163	174
.175. ▶	34001.175.12.C	34001.175.12	34101.175.12.C	34101.175.12	188	199
.200. ▶	34001.200.12.C	34001.200.12	34101.200.12.C	34101.200.12	213	224
.225. ▶	34001.225.12.C	34001.225.12	34101.225.12.C	34101.225.12	238	249
.250. ▶	34001.250.12.C	34001.250.12	34101.250.12.C	34101.250.12	263	274

KMA pivoting to one side: **Moving end 34001...3 / Fixed end 34001...4**

(KMA = Polymer Metal Mounting Bracket)

Part No. structure

**34001.075.12.C A**

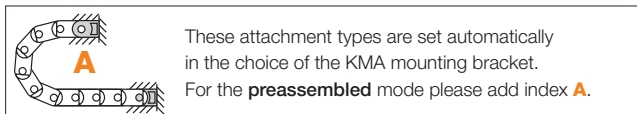
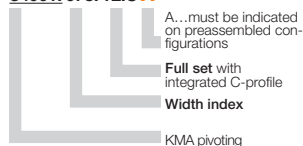

Option: **Steel pivoting Part No. 3000.12** - For e-chains® and e-tubes available

● Pivoting connections ● One part (2-piece) for all e-chain® widths ● Electrically conductive

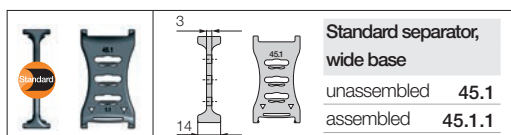
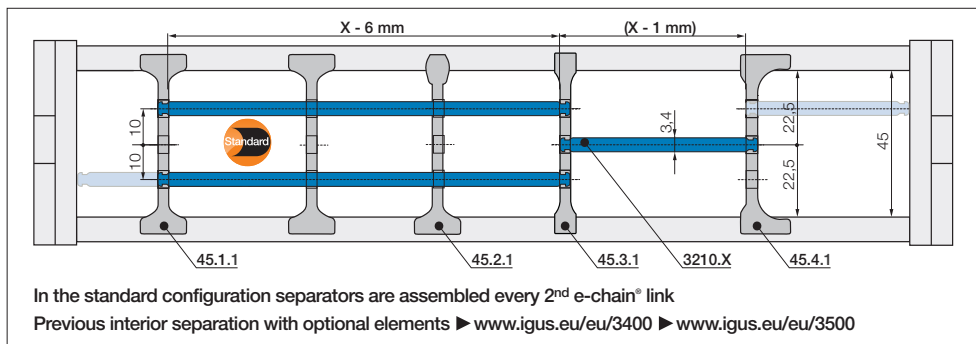

**Strain relief** e.g. clamps, tiwrap plates, nuggets and plug-in clips are available from stock. The complete chainfix range with order options ▶ from page 630

**Standard - for all applications**

Separator with a wide base for maximum locking strength and safe standing in e-chains®.

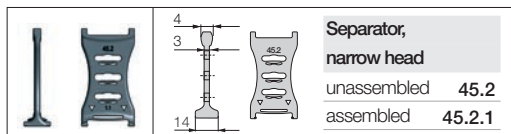
**For even faster installation**

Firm hold to one side with a wide base, narrow on opposed side for easy cable assembly (slight grip).

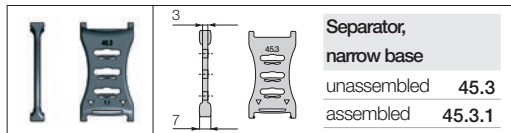
**For many thin cables**

Separator with a narrow base for a large number of thin cables side by side. Saves space in e-chains®.

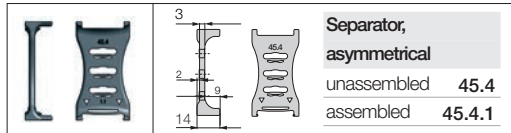
**For side-mounted applications**

Asymmetrical separator, for defined distance. No additional spacers necessary.

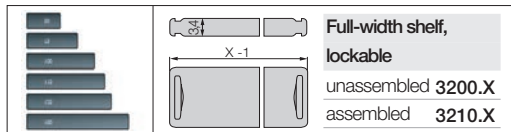
**Horizontal separation**

Full-width shelf locks safely into separators on both ends, fixed width possible. To be used as full-width shelf for a consequent subdivision or as shelf for a pattern system in 3 levels.

**Lockable full-width shelves - for the standard interior separation**

Width X [mm]	unassembled	assembled	Width X [mm]	unassembled	assembled	Width X [mm]	unassembled	assembled
050	3200.050	3210.050	115	3200.115	3210.115	175	3200.175	3210.175
075	3200.075	3210.075	125	3200.125	3210.125			
100	3200.100	3210.100	150	3200.150	3210.150			



## Extender crossbars

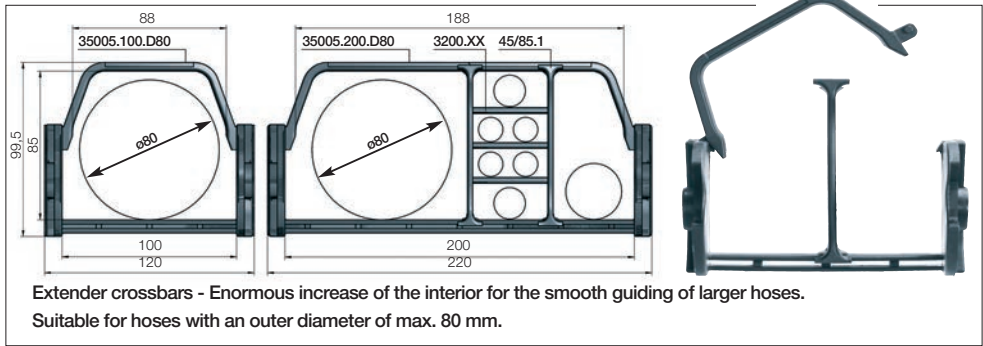

Extender crossbars for e-chains® snap-open along inner radius	Extender crossbars for e-chains® snap-open along outer radius	<i>Bi</i> [mm]	<i>Ba</i> [mm]	<i>R</i> Bending radii [mm]
3400.100 D80.R.0	3500.100 D80.R.0	100	120	075*   100*   125   150   200   250   300
3400.200 D80.R.0	3500.200 D80.R.0	200	220	075*   100*   125   150   200   250   300

\*Radius 075 and 100 only possible with e-chains® Series 3500

Supplement Part No. with required radius. Example: 3500.100D80.200.0

## Interior separation for extender crossbars

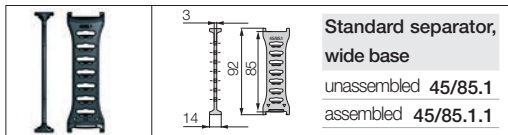

### Standard separator, wide base

For maximum locking strength and safe standing. In standard configuration separators are assembled every 2<sup>nd</sup> link.

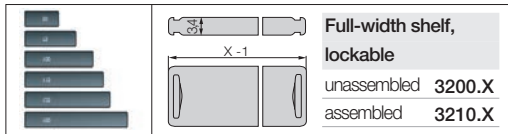

### Horizontal separation

Full-width shelf locks safely into separators on both ends, fixed width possible. Separators can be moved freely over the shelf in horizontal direction. Can be arranged at 7 different heights.

## Separator with integrated strain relief

Strain relief separator Part No. 301.Z can be integrated into the mounting bracket and can be placed there at any point of the e-chain®. It combines strain relief and interior separation, it can be installed on the first or last chain link and is easy to assemble without any screws. **Further Information ► from page 650**



## Optional: Support tray tool kit.

### For support of the lower run.

Simple one-piece support trays according to your requirements and specification.

The complete range with order options ► from page 714



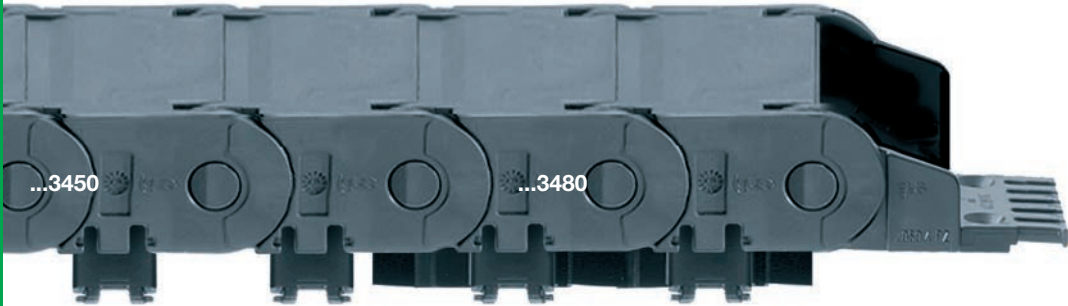

Half e-tubes | Series 3450 snap-open along inner radius, closed along outer radius

Full e-tubes | Series 3480 snap-open along inner radius, fully enclosed

Half e-tubes snap-open along inner radius	Full e-tubes snap-open along inner radius	<i>Bi</i> [mm]	<i>Ba</i> [mm]	<i>R</i> Bending radii [mm]	3450 [kg/m]	3480 [kg/m]
3450.050. <i>R</i> .0	3480.050. <i>R</i> .0	50	70	075* 100* 125 150 200 250 300	≈ 1,77	≈ 1,96
3450.075. <i>R</i> .0	3480.075. <i>R</i> .0	75	95	075* 100* 125 150 200 250 300	≈ 1,95	≈ 2,07
3450.100. <i>R</i> .0	3480.100. <i>R</i> .0	100	120	075* 100* 125 150 200 250 300	≈ 2,15	≈ 2,30
3450.115. <i>R</i> .0	3480.115. <i>R</i> .0	115	135	075* 100* 125 150 200 250 300	≈ 2,30	≈ 2,46
3450.125. <i>R</i> .0	3480.125. <i>R</i> .0	125	145	075* 100* 125 150 200 250 300	≈ 2,42	≈ 2,49
3450.150. <i>R</i> .0	3480.150. <i>R</i> .0	150	170	075* 100* 125 150 200 250 300	≈ 2,60	≈ 2,62
3450.175. <i>R</i> .0	3480.175. <i>R</i> .0	175	195	075* 100* 125 150 200 250 300	≈ 2,75	≈ 2,80
3450.200. <i>R</i> .0	3480.200. <i>R</i> .0	200	220	075* 100* 125 150 200 250 300	≈ 2,90	≈ 2,94
3450.225. <i>R</i> .0	3480.225. <i>R</i> .0	225	245	075* 100* 125 150 200 250 300	≈ 3,15	≈ 3,12
3450.250. <i>R</i> .0	3480.250. <i>R</i> .0	250	270	075* 100* 125 150 200 250 300	≈ 3,30	≈ 3,28

\*Radius available upon request, please consult igus® for delivery time

Radii 075, 100: the e-tube is not completely enclosed. Please consult igus®

Supplement Part No. with required radius. Example: 3450.075.200.0

### Open e-chains® in a flash with the igus® e-chain® opener

Reduce assembly time from 33 to 2 sec. with the igus® e-chain® Opener. Open a long piece of e-chain® in one go. Part No. 908.254.3400 for Series 3450. For widths *Bi* [mm]: 050, 075, 100, 115.

Further information and video ► [www.igus.eu/eu/savetime](http://www.igus.eu/eu/savetime)





## Unsupported applications | Short travels

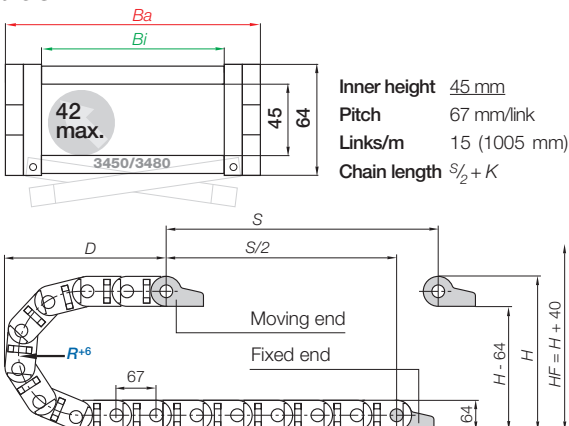
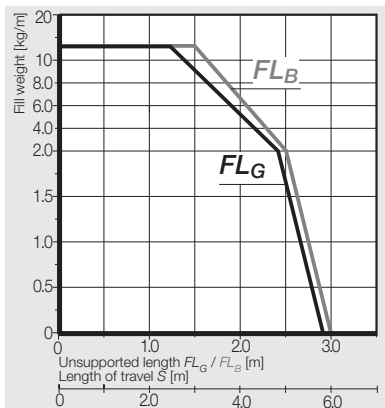

Inner height 45 mm  
Pitch 67 mm/link  
Links/m 15 (1005 mm)  
Chain length  $\frac{S}{2} + K$

R	075*	100*	125	150	200	250	300
H	214	264	314	364	464	564	664
D	208	233	258	283	333	383	433
K	370	450	530	610	765	920	1080

The required clearance height:  $H_F = H + 40$  mm (with 2,5 kg/m fill weight)

\*Radius available upon request, please consult igus\* for delivery time Before using Series 3450/3480 on long travels please consult igus\*.

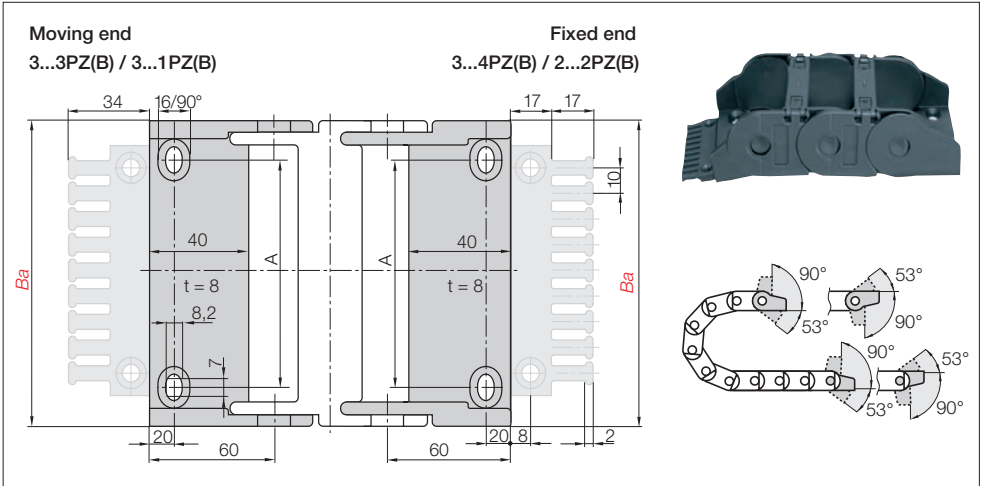

**Polymer pivoting** | Standard | Recommended for unsupported applications

**Polymer locking** | Recommended for vertical hanging and standing applications

Width Index	Standard	Part No. full set <b>pivoting</b> :		Part No. full set <b>locking</b> :		Dim A [mm]	Number of teeth
		with tiewrap plates	without tiewrap plates	with tiewrap plates	without tiewrap plates		
.050.	▶	3050.34PZB	3050.34PZ	3050.12PZB	3050.12PZ	28	5
.075.	▶	3075.34PZB	3075.34PZ	3075.12PZB	3075.12PZ	53	7
.100.	▶	3100.34PZB	3100.34PZ	3100.12PZB	3100.12PZ	78	10
.115.	▶	3115.34PZB	3115.34PZ	3115.12PZB	3115.12PZ	93	11
.125.	▶	3125.34PZB	3125.34PZ	3125.12PZB	3125.12PZ	103	12
.150.	▶	3150.34PZB	3150.34PZ	3150.12PZB	3150.12PZ	128	15
.175.	▶	3175.34PZB	3175.34PZ	3175.12PZB	3175.12PZ	153	17
.200.	▶	3200.34PZB	3200.34PZ	3200.12PZB	3200.12PZ	178	20
.225.	▶	3225.34PZB	3225.34PZ	3225.12PZB	3225.12PZ	203	22
.250.	▶	3250.34PZB	3250.34PZ	3250.12PZB	3250.12PZ	228	25

Full set with tiewrap plate + 10 cable tiewraps, please add index **K1** ▶ e.g. 3250.34PZBK1

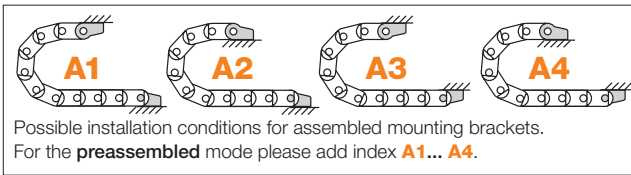

Part No. structure

**3075. 34 PZB A1**

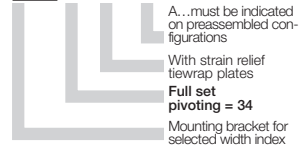

 **Strain relief** e.g. clamps, tiewrap plates, nuggets and plug-in clips are available from stock. The complete chainfix range with order options ▶ from page 630

KMA mounting brackets | Attachment on all sides | pivoting | locking

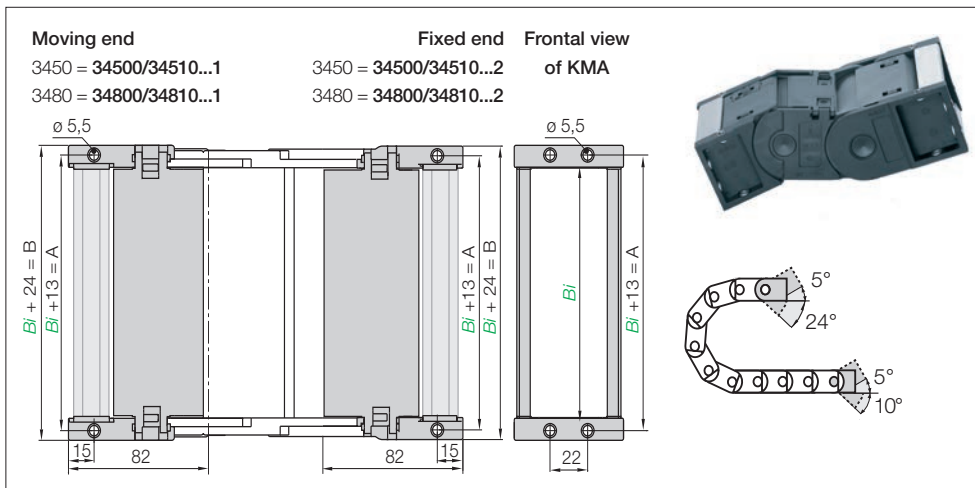

**KMA pivoting** | Recommended for unsupported applications

**KMA locking** | Recommended for vertical hanging and standing applications

Width Index	Part No. full set <b>KMA pivoting:</b>				Part No. full set <b>KMA locking:</b>				Dim A [mm]	Dim A [mm]
	with C-profile		without C-profile		with C-profile		without C-profile			
.050. ▶	34500	34800.050.12.C	34500	34800.050.12	34510	34810.050.12.C	34510	34810.050.12	63	74
.075. ▶	34500	34800.075.12.C	34500	34800.075.12	34510	34810.075.12.C	34510	34810.075.12	88	99
.100. ▶	34500	34800.100.12.C	34500	34800.100.12	34510	34810.100.12.C	34510	34810.100.12	113	124
.115. ▶	34500	34800.115.12.C	34500	34800.115.12	34510	34810.115.12.C	34510	34810.115.12	128	139
.125. ▶	34500	34800.125.12.C	34500	34800.125.12	34510	34810.125.12.C	34510	34810.125.12	138	149
.150. ▶	34500	34800.150.12.C	34500	34800.150.12	34510	34810.150.12.C	34510	34810.150.12	163	174
.175. ▶	34500	34800.175.12.C	34500	34800.175.12	34510	34810.175.12.C	34510	34810.175.12	188	199
.200. ▶	34500	34800.200.12.C	34500	34800.200.12	34510	34810.200.12.C	34510	34810.200.12	213	224
.225. ▶	34500	34800.225.12.C	34500	34800.225.12	34510	34810.225.12.C	34510	34810.225.12	238	249
.250. ▶	34500	34800.250.12.C	34500	34800.250.12	34510	34810.250.12.C	34510	34810.250.12	263	274

**KMA pivoting:** Part No. 34500... for half e-tube Series 3450 / Part No. 34800... for full e-tube Series 3480

**KMA locking:** Part No. 34510... for half e-tube Series 3450 / Part No. 34810... for full e-tube Series 3480

(KMA = Polymer Metal Mounting Bracket)

Part No. structure

**34500.075.12.C A**

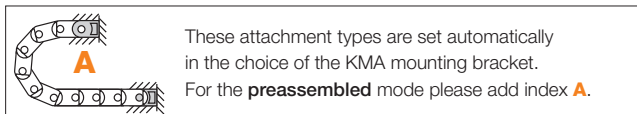
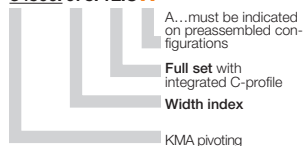

Option: **Steel pivoting** Part No. 3000.12 - For e-chains® and e-tubes available

● Pivoting connections ● One part (2-piece) for all e-chain® widths ● Electrically conductive

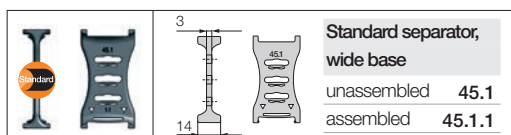
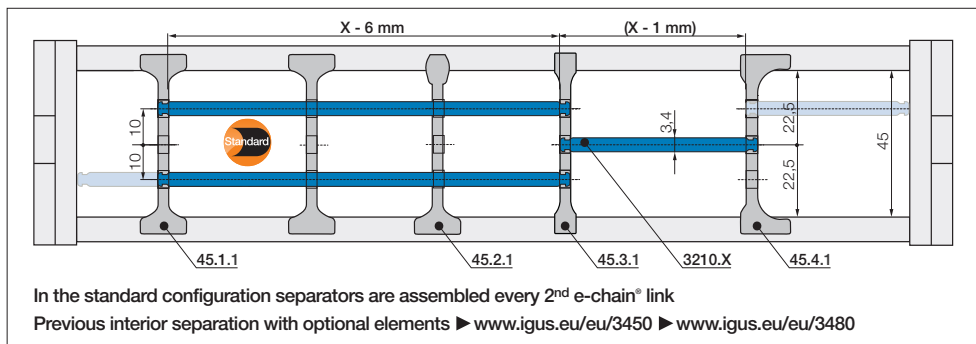

**Strain relief** e.g. clamps, tiwrap plates, nuggets and plug-in clips are available from stock. The complete chainfix range with order options ▶ from page 630

**Standard - for all applications**

Separator with a wide base for maximum locking strength and safe standing in e-chains®.

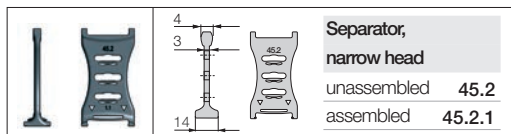
**For even faster installation**

Firm hold to one side with a wide base, narrow on opposed side for easy cable assembly (slight grip).

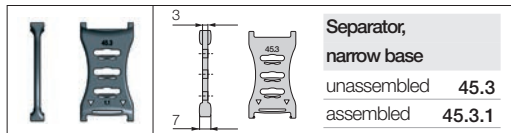
**For many thin cables**

Separator with a narrow base for a large number of thin cables side by side. Saves space in e-chains®.

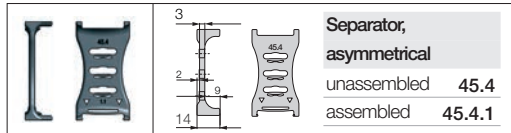
**For side-mounted applications**

Asymmetrical separator, for defined distance. No additional spacers necessary.

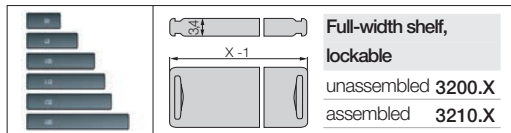
**Horizontal separation**

Full-width shelf locks safely into separators on both ends, fixed width possible. To be used as full-width shelf for a consequent subdivision or as shelf for a pattern system in 3 levels.

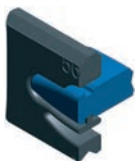
**Lockable full-width shelves - for the standard interior separation**

Width X [mm]	unassembled	assembled	Width X [mm]	unassembled	assembled	Width X [mm]	unassembled	assembled
050	3200.050	3210.050	115	3200.115	3210.115	175	3200.175	3210.175
075	3200.075	3210.075	125	3200.125	3210.125			
100	3200.100	3210.100	150	3200.150	3210.150			

## Extender crossbars

Extender crossbars only for Series 3450 - Enormous increase of the interior for the smooth guiding of larger hoses. Suitable for hoses with an outer diameter of max. 80 mm.

Extender crossbars for half e-tubes snap-open along inner radius	<i>Bi</i> [mm]	<i>Ba</i> [mm]	<i>R</i> Bending radii [mm]				
3450.100 D80. <i>R</i> .0	100	120	125	150	200	250	300
3450.200 D80. <i>R</i> .0	200	220	125	150	200	250	300

Supplement Part No. with required radius. Example: 3450.100D80.200.0

## Interior separation for extender crossbars

**Standard separator, wide base**  
unassembled 45/85.1  
assembled 45/85.1.1

### Standard separator, wide base

For maximum locking strength and safe standing. In standard configuration separators are assembled every 2<sup>nd</sup> link.

**Full-width shelf, lockable**  
unassembled 3200.X  
assembled 3210.X

### Horizontal separation

Full-width shelf locks safely into separators on both ends, fixed width possible. Separators can be moved freely over the shelf in horizontal direction. Can be arranged at 7 different heights.

## Separator with integrated strain relief

Strain relief separator Part No. 34501.Z can be integrated into the mounting bracket and can be placed there at any point of the e-chain®. It combines strain relief and interior separation, it can be installed on the first or last chain link and is easy to assemble without any screws. **Further Information ► from page 650**



## Optional: Support tray tool kit.

### For support of the lower run.

Simple one-piece support trays according to your requirements and specification.

The complete range with order options ► from page 714



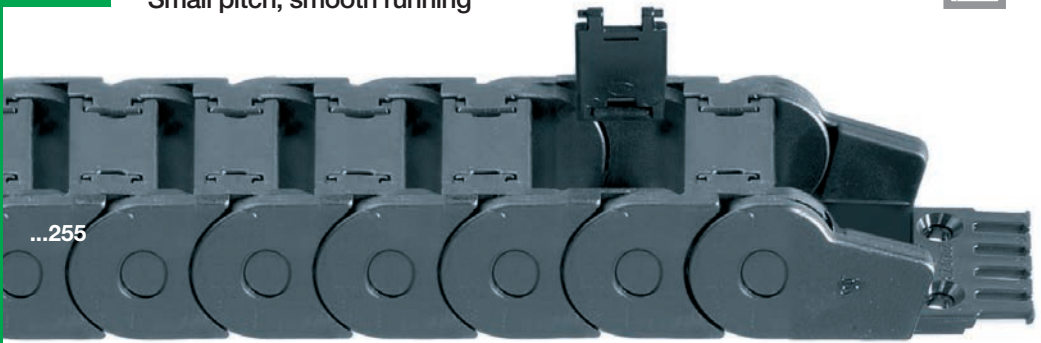

## Series 255 | Snap-open along outer radius

Snap-open along inner radius	<i>Bi</i> [mm]	<i>Ba</i> [mm]	<i>R</i> Bending radii [mm]	Weight [kg/m]
255.03. <i>R</i> .0	38	54	055   075   100   125   150   175   200   225   250	≈ 0,81
255.05. <i>R</i> .0	57	73	055   075   100   125   150   175   200   225   250	≈ 0,90
255.07. <i>R</i> .0	77	93	055   075   100   125   150   175   200   225   250	≈ 1,01
255.10. <i>R</i> .0	103	119	055   075   100   125   150   175   200   225   250	≈ 1,15

Supplement Part No. with required radius. Example: 255.10.200.0





## Unsupported applications | Short travels

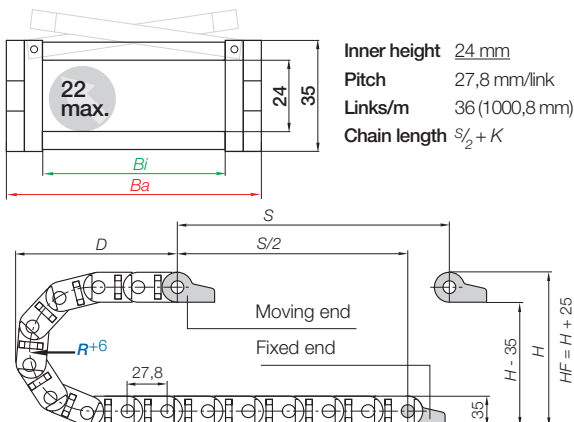
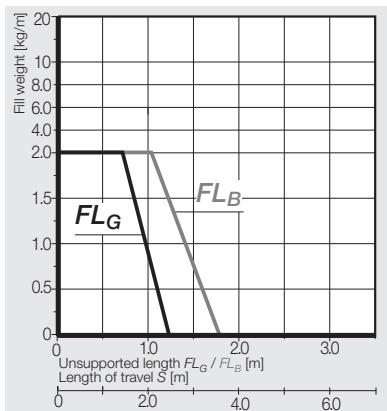

R	055	075	100	125	150	175	200	225	250
$H+4_0$	145	185	235	285	335	385	435	485	535
D	114	134	159	184	209	234	259	284	309
K	230	295	370	450	530	610	685	765	845

The required clearance height:  $H_F = H + 25$  mm (with 1,5 kg/m fill weight)

## Gliding applications | Long travels from 10 m to max. 100 m

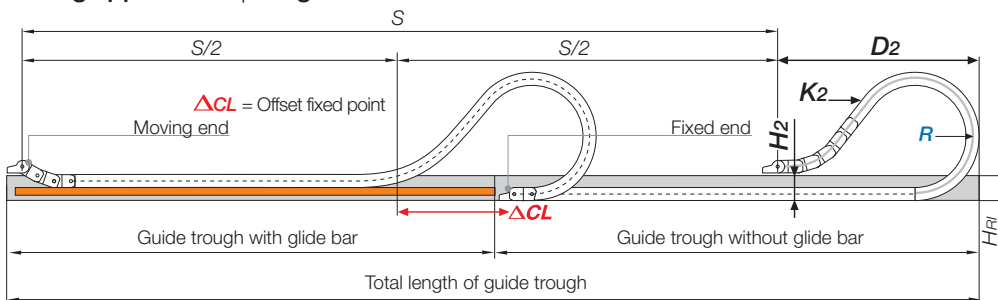

Solution for long travel applications. We recommend to realize the engineering of such a plant by our technicians.

In case of travels between 4 and 10 m we recommend a longer unsupported length. Chain length  $S/2 + K_2$

R	055	075	100	125	150	175	200	225	250
$H_2$	110	150	100	100	100	100	100	100	100
$D_2+25$	114	134	380	495	570	665	740	1040	1130
$K_2$	230	295	612	806	945	1112	1223	1610	1779
$\Delta CL$	-	-	222	322	372	437	497	*	822

\*Values upon request

# E2 medium | Series 255 | Accessories

## Mounting brackets, polymer | pivoting | locking

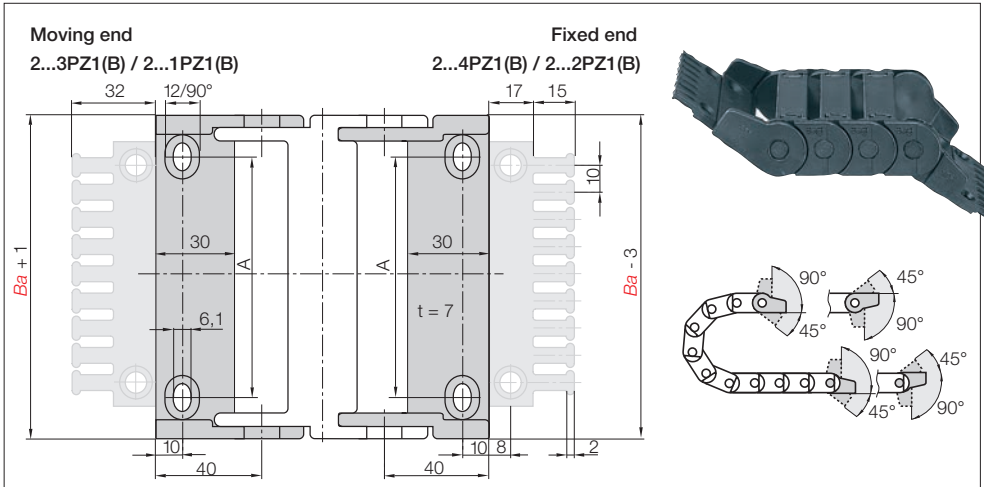

**Polymer pivoting** | Standard | Recommended for unsupported and gliding applications  
**Polymer locking** | Recommended for vertical hanging and standing applications

Width Index	Standard	Part No. full set <b>pivoting</b> :		Part No. full set <b>locking</b> :		Dim A [mm]	Number of teeth
		with tiewrap plates	without tiewrap plates	with tiewrap plates	without tiewrap plates		
.03.	▶	2030.34PZ1B	2030.34PZ1	2030.12PZ1B	2030.12PZ1	25	4
.05.	▶	2050.34PZ1B	2050.34PZ1	2050.12PZ1B	2050.12PZ1	44	6
.07.	▶	2070.34PZ1B	2070.34PZ1	2070.12PZ1B	2070.12PZ1	64	8
.10.	▶	2100.34PZ1B	2100.34PZ1	2100.12PZ1B	2100.12PZ1	90	10

Full set with tiewrap plate + 10 cable tiewraps, please add index **K1** ▶ e.g. 2030.34PZ1BK1

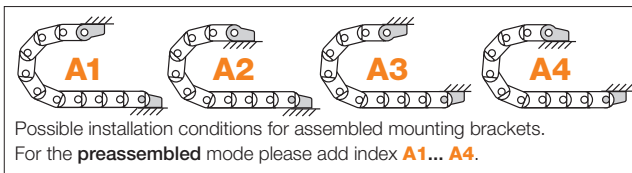

Part No. structure

2100.34 PZB **A1**

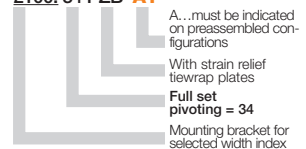

**Strain relief** e.g. clamps, tiewrap plates, nuggets and plug-in clips are available from stock. The complete chainfix range with order options ▶ from page 630

Interior separation

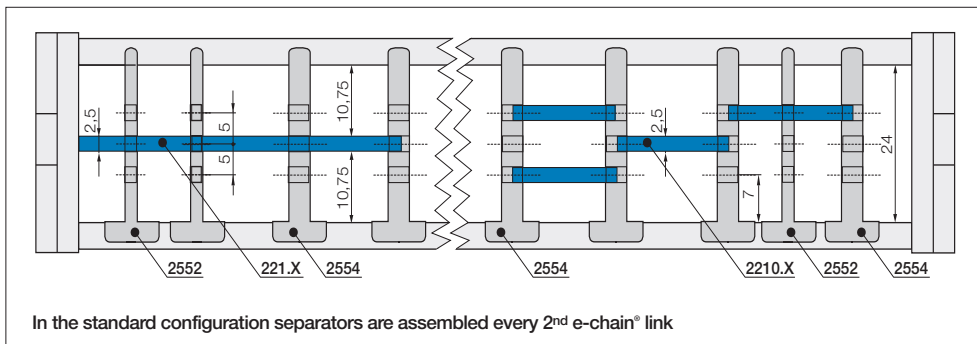

**Slotted separator for e-chains®**

unassembled	<b>2551</b>
assembled	<b>2552</b>

**Standard slotted separator 2551**

Due to its slot, it allows basic vertical/horizontal shelving arrangements (determining which type of separator to use depends on any potential retrofit requirements).

**Full-width shelf for e-tubes**

unassembled	<b>220.X</b>
assembled	<b>221.X</b>

**Full-width shelf 220.X**

This option makes sense in applications with many thin cables with similar diameters. For a consequent subdivision. Full-width shelves can be arranged at 3 different heights (in 5 mm increments).

**Full-width shelves**

Width X [mm]	unassembled	assembled	Width X [mm]	unassembled	assembled
038	<b>220.38</b>	<b>221.38</b>	077	<b>220.77</b>	<b>221.77</b>
057	<b>220.57</b>	<b>221.57</b>	103	<b>220.103</b>	<b>221.103</b>

**Slotted separator for e-chains®**

unassembled	<b>2553</b>
assembled	<b>2554</b>

**Slotted separator 2553**

Due to its slot, it allows basic vertical/horizontal shelving arrangements (determining which type of separator to use depends on any potential retrofit requirements).

**Shelf for e-chains®**

unassembled	<b>2200.X</b>
assembled	<b>2210.X</b>

**Shelf 2200.X**

For applications involving many cables with different diameters, shelves can be arranged at alternate heights. They can be arranged at 3 different heights (in 5 mm increments).

**Shelves**

Width X [mm]	unassembled	assembled	Width X [mm]	unassembled	assembled	Width X [mm]	unassembled	assembled
018	<b>2200.18</b>	<b>2210.18</b>	038	<b>2200.38</b>	<b>2210.38</b>	068	<b>2200.68</b>	<b>2210.68</b>
023	<b>2200.23</b>	<b>2210.23</b>	043	<b>2200.43</b>	<b>2210.43</b>	073	<b>2200.73</b>	<b>2210.73</b>
028	<b>2200.28</b>	<b>2210.28</b>	048	<b>2200.48</b>	<b>2210.48</b>	088	<b>2200.88</b>	<b>2210.88</b>
033	<b>2200.33</b>	<b>2210.33</b>	058	<b>2200.58</b>	<b>2210.58</b>	099	<b>2200.99</b>	<b>2210.99</b>



Universal:  
Attachment on all sides

Chip protection:  
Smooth, chip-  
repellent exterior

Long lifetime:  
Lateral gliding  
surfaces

Quick assembly:  
Snap-open  
accessibility along  
inner or outer radius

Space-efficient:  
Optimized ratio of inner  
to outer dimension

Long service life:  
Double stop dog for strong  
unsupported length

Dirt repellent:  
Covered  
pin/bore connection



iF produkt design award  
2000 Series R117/R118

# E2 Series R100 - protection against dirt and debris, cost effective

E2 Series R100 - cost effective, for applications with low and medium speeds. e-tubes R100 work in hot chip areas, in areas of dirt and dust generated by woodworking, steel-mills, pulp and paper, textile, agriculture, coal-fired plants and many other hostile environments.

- Very good protection against chips (including hot chips)
- Robust and tight
- Space-efficient with optimized ratio of inner dimension to outer dimension
- Modular interior separation
- Universal KMA mounting brackets with attachment options on all sides

## Typical industries and applications

- Tooling machines
- Woodworking machines
- All kind of industries and machines with chip, dirt and dust



e-tubes with igumid HT-Material for hot chips up to 850°C available upon request



Electrically conductive  
ESD/ATEX versions upon request



UL94-V0 classification  
upon request



# E2 e-tubes R100 | Selection Table

Series	Inner height <i>hi</i> [mm]	Inner width <i>Bi</i> [mm]	Outer width <i>Ba</i> [mm]	Outer height <i>ha</i> [mm]	Bending radius <i>R</i> [mm]	Unsupported max. length [m]	Page
--------	--------------------------------	-------------------------------	-------------------------------	--------------------------------	---------------------------------	--------------------------------	------



**E2 e-tubes R100 -**  
hinged, snap-open on both  
sides of the inner radius

<b>R117</b>	21	20 - 100	32 - 112	28	63 - 180	1,20	<b>302</b>
<b>R157</b>	40	40 - 200	56 - 216	50	100 - 250	2,25	<b>306</b>
<b>R167</b>	50	50 - 250	68 - 268	64	100 - 300	2,50	<b>314</b>



**E2 e-tubes R100 -**  
**Standard**  
hinged, snap-open on both  
sides of the outer radius

<b>R118</b>	21	25 - 80	37 - 92	28	63 - 180	1,20	<b>302</b>
<b>R158</b>	40	40 - 200	56 - 216	50	100 - 250	2,25	<b>306</b>
<b>R168</b>	50	50 - 200	68 - 218	64	100 - 300	2,50	<b>314</b>

## Technical Data



Gliding speed / acceleration (maximum)

upon request <sup>1)</sup>

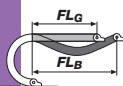

Speed / acceleration  $FL_G$  max.

max. 10 [m/s] / max. 100 [m/s<sup>2</sup>]

Speed / acceleration  $FL_B$  max.

max. 3 [m/s] / max. 6 [m/s<sup>2</sup>]



e-tube material - permitted temperature °C

igumid G / -40° up to +120° C







Flammability class, igumid G

VDE 0304 IIC UL94-HB

■  $FL_G$  = with straight upper run ■  $FL_B$  = with permitted sag



1) In special cases, gliding applications are also possible, please consult igus®.

## Installation methods overview, maximum travels

Series e-tube	 Unsupported application	 Vertical hanging	 Vertical standing	 Side mounted unsupported
R117 / R118	≤ 1,20 m	≤ 20 m	≤ 2,0 m	≤ 0,7 m
R157 / R158	≤ 2,25 m	≤ 40 m	≤ 3,0 m	≤ 1,0 m
R167 / R168	≤ 2,50 m	≤ 50 m	≤ 3,0 m	≤ 1,0 m

# E2 e-tubes R100 | Order keys and Options

## Options with order keys based on Series R167

 <p><i>Standard</i></p> <p>Part No. <b>Standard</b> e-tubes</p> 	<p><i>NC-Version - (no camber) without pretension</i></p> <p>Part No. <b>NC-Version</b> e-tubes</p> <p>NC</p> 	<p><i>No burning-in of hot chips up to 850°C (1562°F)</i></p> <p>Part No. <b>igumid HT-Material</b> only for e-tubes</p> 	<p><i>ESD / ATEX classified e-chains®</i></p> <p> II 2 GD</p> <p>Part No. <b>ESD-Material</b> e-tubes</p> 
 <p><b>168.100.R.0</b></p>	<p><b>168.100.R.0.NC</b></p>	<p><b>168.100.R.0.HT</b></p>	<p><b>168.100.R.0.ESD</b></p>
 <p><b>Delivery from stock</b></p>	<p><b>Delivery time: upon request</b></p>	<p><b>Delivery time: upon request</b></p>	<p><b>Delivery time: upon request</b></p>

## Order example | Order key and color options based on Series R168











 **Order example for complete e-tube (1,0 m), color black, with mounting brackets and interior separation:**

<b>e-tube (1,0 m)</b>	Please indicate e-tube length or number of links: 1,0 m or 17 links	<b>168.100.100.0</b>
<b>+ Mounting brackets</b>	KMA, extended - 1set	<b>1680.100.12</b>
<b>+ Interior separation</b>	with 2 separators assembled every 2 <sup>nd</sup> link	<b>2 x 1686.01</b>
Order text: 1,0 m <b>168.100.100.0</b> + <b>1680.100.12</b> + 2 x <b>1686.01</b>		

### Order key

e-tube snap-open along outer radius	<b>168.100.100.0</b>
e-tube snap-open along inner radius	<b>167.100.100.0</b>
Series / Type	
Width index (depends on <i>B</i> )	<i>B</i>
Bending radius <i>R</i>	<i>R</i>
Color index (standard black)	Color

### General igus® color options for e-chains® and e-tubes

Color	Order index	Color	Order index
 <b>Black</b> Standard, from stock!	<b>.0</b>	 <b>White</b> special color	<b>.1</b>
 <b>Slate grey</b> only ESD material	<b>.ESD</b>	 <b>Gray white</b> special color	<b>.1S</b>
 <b>Gray brown</b> only HT material	<b>.HT</b>	 <b>Orange</b> special color	<b>.2</b>
 <b>Gray</b> special color only e-chains®	<b>.3</b>	 <b>Yellow</b> special color	<b>.4</b>
 <b>Dusty grey</b> special color only e-tubes	<b>.31</b>	 <b>Light grey</b> special color	<b>.14</b>

**Black e-chains® available from stock!**  
**Delivery time for special colors: upon request**

**168.100.100.0** = e-tube snap-open on both sides of the outer radius, inner width *Bi* 100 mm, radius *R* 100 mm, color black  
**167.100.100.0** = e-tube snap-open on both sides of the inner radius, inner width *Bi* 100 mm, radius *R* 100 mm, color black



Series R117 | Hinged, snap-open on both sides of the inner radius

Series R118 | Hinged, snap-open on both sides of the outer radius | Standard

e-tubes snap-open along inner radius	e-tubes snap-open along outer radius 	<i>B<sub>i</sub></i> [mm]	<i>B<sub>a</sub></i> [mm]	<i>R</i> Bending radii [mm]								R117 [kg/m]	R118 [kg/m]
117.020. <i>R.0</i>	118.020. <i>R.0</i> *	20	32	063	075	100	110	125	145	180	≈ 0,43	≈ 0,43	
117.025. <i>R.0</i>	118.025. <i>R.0</i>	25	37	063	075	100	110	125	145	180	≈ 0,46	≈ 0,46	
117.038. <i>R.0</i>	118.038. <i>R.0</i> *	38	50	063	075	100	110	125	145	180	≈ 0,56	≈ 0,56	
117.048. <i>R.0</i>	118.048. <i>R.0</i>	48	60	063	075	100	110	125	145	180	≈ 0,66	≈ 0,66	
117.063. <i>R.0</i>	118.063. <i>R.0</i> *	63	75	063	075	100	110	125	145	180	≈ 0,76	≈ 0,76	
117.080. <i>R.0</i>	118.080. <i>R.0</i>	80	92	063	075	100	110	125	145	180	≈ 0,89	≈ 0,89	
117.100. <i>R.0</i>	118.100. <i>R.0</i> *	100	112	063	075	100	110	125	145	180	≈ 1,06	≈ 1,06	

\*Width available upon request, please consult igus® for delivery time

Supplement Part No. with required radius. Example: 118.080.100.0

### Hot Chips up to 850°C

e-tubes that repel hot chips, up to 850 °C. Some applications, depending on amount and size of the chips, can burn or melt the surface. That is no longer the case with the igus® "igumid HT" material. Order example: Full e-tube made of igumid HT:

**Part No. 118.080.100.0.HT** (for long travels upon request)

Delivery time upon request. **Further Information** ► [www.igus.eu/eu/HT](http://www.igus.eu/eu/HT)

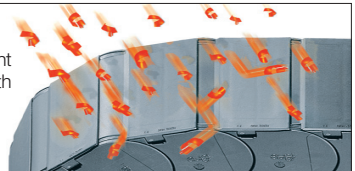





## Unsupported applications | Short travels

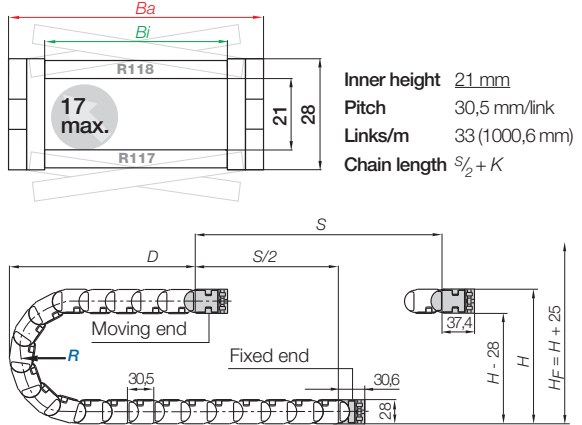
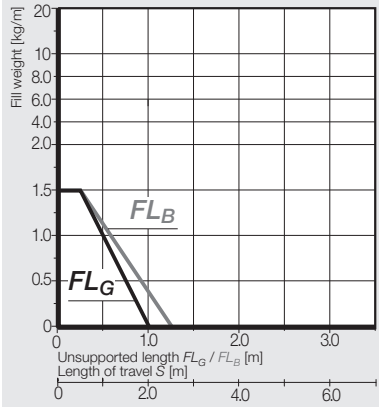

R	063	075	100	110	125	145	180
H	154	178	228	248	278	318	388
D	123	135	160	170	185	205	240
K	260	300	380	410	455	520	630

The required clearance height:  $H_F = H + 25$  mm (with 1,0 kg/m fill weight)

## Interior separation | Standard

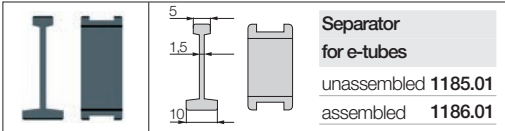

### Vertical Separator 1185.01

Vertical Separators are used if a vertical subdivision of the e-tube interior is required - By standard Vertical Separators are assembled every other e-tube link.

# E2 e-tubes R100 | R117·R118 | Accessories

## KMA mounting brackets | Attachment on all sides | one side pivoting

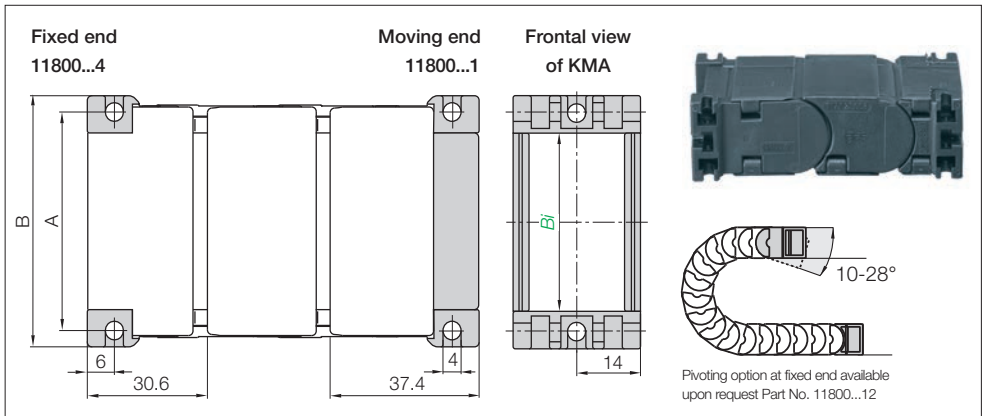

### KMA one side pivoting | Recommended for short travels | Standard

Width Index	Part No. full set <b>KMA one side pivoting:</b>	Dim A [mm]	Dim B [mm]
020. ▶	<b>11800.020.14</b>	29	36
025. ▶	<b>11800.025.14</b>	34	41
038. ▶	<b>11800.038.14</b>	47	54
048. ▶	<b>11800.048.14</b>	57	64
063. ▶	<b>11800.063.14</b>	72	79
080. ▶	<b>11800.080.14</b>	89	96
100. ▶	<b>11800.100.14</b>	109	116

(KMA = Polymer Metal Mounting Bracket)

The mounting brackets are supplied with hexagon nuts and can be attached with M4 bolts, or the mounting brackets may also be attached with M4 socket head cap bolts.

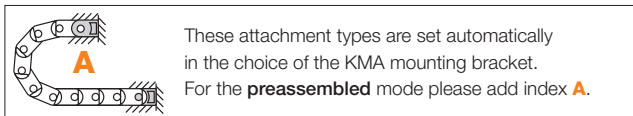

#### Part No. structure

<b>11800.020.14 A</b>	A...must be indicated on preassembled configurations
11800.020.14	Full set
11800.020.14	Width index
11800.020.14	KMA pivoting



**Strain relief** e.g. clamps, tie-wrap plates, nuggets and plug-in clips are available from stock. The complete chainfix range with order options ▶ from page 630

## Mounting brackets, angled, polymer | one side pivoting

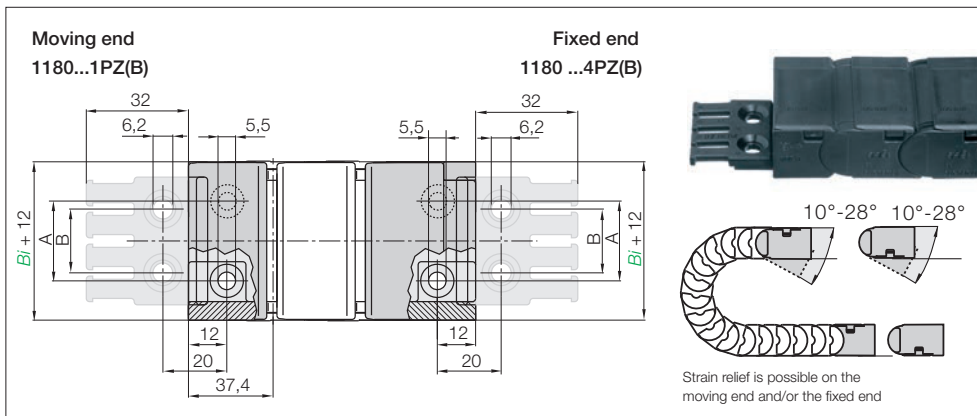

### Angled polymer bracket one side pivoting | Recommended for short travels

Width Index	Part No. full set with tiewrap plates	Part No. full set without tiewrap plates	Dim A [mm]	Dim B [mm]	Number of teeth
025. ▶	1180.025.14PZB	1180.025.14PZ	12	15	3
038. ▶	1180.038.14PZB	1180.038.14PZ	25	20	4
048. ▶	1180.048.14PZB	1180.048.14PZ	35	30	5
063. ▶	1180.063.14PZB	1180.063.14PZ	50	40	6
080. ▶	1180.080.14PZB	1180.080.14PZ	67	60	8
100. ▶	1180.100.14PZB	1180.100.14PZ	87	80	10

The following parts are required for attachment of the mounting brackets:

- Countersunk bolt M5 DIN 912-8.8 Length depends on the thickness of the attachment base
- Hexagon nut M5 DIN 934-8

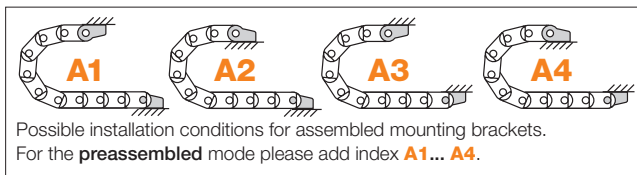

#### Part No. structure

**1180.048.14PZBA1** A... must be indicated on preassembled configurations  
 With strain relief tiewrap plates  
**Full set**  
**Width index**  
 Mounting bracket for selected width index



**Strain relief** e.g. clamps, tiewrap plates, nuggets and plug-in clips are available from stock. The complete chainfix range with order options ▶ from page 630

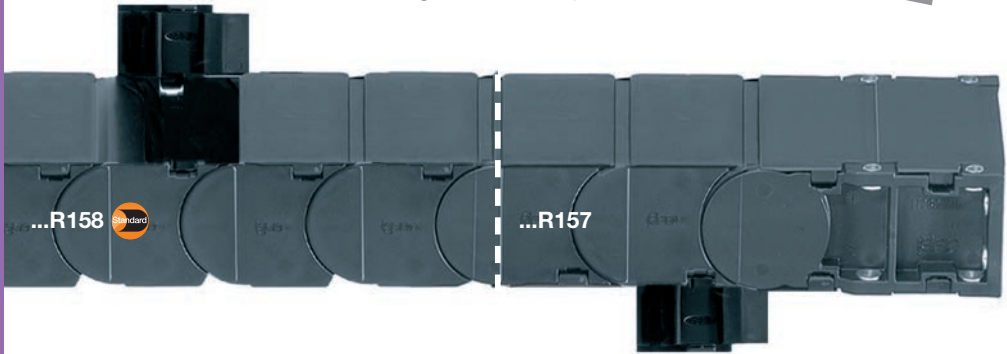

Series R157 | Hinged, snap-open on both sides of the inner radius

Series R158 | Hinged, snap-open on both sides of the outer radius | Standard

e-tubes snap-open along inner radius	e-tubes snap-open along outer radius 	<i>B<sub>i</sub></i> [mm]	<i>B<sub>a</sub></i> [mm]	<i>R</i> Bending radii [mm]						R157 [kg/m]	R158 [kg/m]
157.040 .R.0 <sup>1)</sup>	158.040 .R.0 <sup>1)</sup>	40	56	100	125	150	175	200	250	≈ 1,21	≈ 1,21
157.050 .R.0	158.050 .R.0	50	66	100	125	150	175	200	250	≈ 1,30	≈ 1,30
157.075 .R.0	158.075 .R.0	75	91	100	125	150	175	200	250	≈ 1,50	≈ 1,50
157.088 .R.0	158.088 .R.0	88	104	100	125	150	175	200	250	≈ 1,57	≈ 1,57
157.090 .R.0 <sup>2)</sup>	158.090 .R.0 <sup>2)</sup>	88	104	100	125	150	175	200	250	≈ 1,63	≈ 1,63
157.100 .R.0	158.100 .R.0	100	116	100	125	150	175	200	250	≈ 1,71	≈ 1,71
157.125 .R.0	158.125 .R.0	125	141	100	125	150	175	200	250	≈ 1,92	≈ 1,92
157.135 .R.0	158.135 .R.0	135	150	100	125	150	175	200	250	≈ 2,10	≈ 2,10
157.150 .R.0	158.150 .R.0	150	166	100	125	150	175	200	250	≈ 2,13	≈ 2,13
157.175 .R.0	158.175 .R.0	175	191	100	125	150	175	200	250	≈ 2,34	≈ 2,34
157.200 .R.0	158.200 .R.0	200	216	100	125	150	175	200	250	≈ 2,55	≈ 2,55

1) Lid removable only, not hinged

2) Same dimensions as 157.088 - less recent design, no hinged option

Supplement Part No. with required radius. Example: **158.100.100.0**

### Hot Chips up to 850°C

e-tubes that repel hot chips, up to 850 °C. Some applications, depending on amount and size of the chips, can burn or melt the surface. That is no longer the case with the igus® "igumid HT" material. Order example: Full e-tube made of igumid HT:

**Part No. 158.100.100.0.HT** (for long travels upon request)

Delivery time upon request. **Further Information** ► [www.igus.eu/eu/HT](http://www.igus.eu/eu/HT)

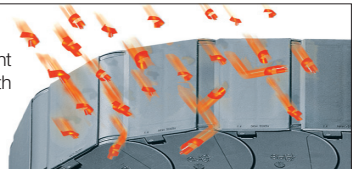



## Unsupported applications | Short travels

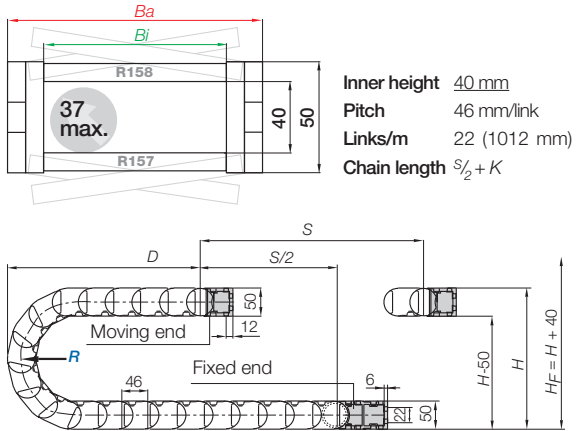
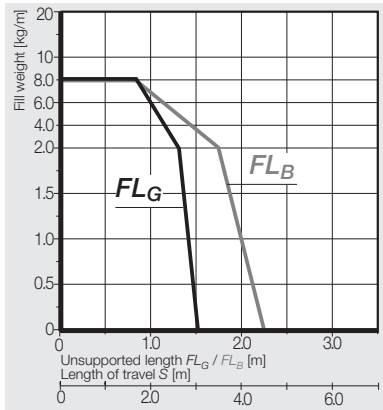

R	100	125	150	175	200	250
H	250	300	350	400	450	550
D	194	219	244	269	294	344
K	410	485	565	645	725	880

The required clearance height:  $H_F = H + 40$  mm (with 1,0 kg/m fill weight)

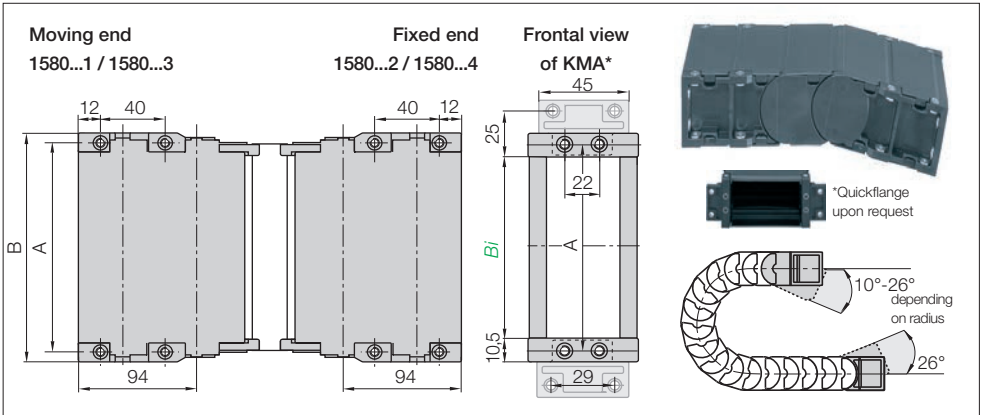

**KMA, extended pivoting | Recommended for short travels | Standard**

**KMA, extended locking | Recommended for vertical hanging, standing applications**

Width Index		Part No. full set <b>KMA pivoting:</b>	Part No. full set <b>KMA locking:</b>	Dim A [mm]	Dim B [mm]
.040.	▶	15801.040.12	15801.040.34	50	61
.050.	▶	15800.050.12	15800.050.34	60	71
.075.	▶	15800.075.12	15800.075.34	85	96
.088.	▶	15800.088.12	15800.088.34	98	109
.090.	▶	15801.090.12	15801.090.34	98	109
.100.	▶	15800.100.12	15800.100.34	110	121
.125.	▶	15800.125.12	15800.125.34	135	146
.135.	▶	15800.135.12	15800.135.34	145	156
.150.	▶	15800.150.12	15800.150.34	160	171
.175.	▶	15800.175.12	15800.175.34	185	196
.200.	▶	15800.200.12	15800.200.34	210	221

Full set with assembled Quickflange, please add index **QF** ▶ e.g. **15800.200.12.QF**. Quickflange unassembled: **Part No. 15800.QF**

KMA = Polymer Metal Mounting Bracket)

The following parts are required for attachment of the mounting brackets:

- Socket head cap bolt M5 DIN 912-8.8 Length depends on the thickness of the attachment base
- Hexagon nut M5 DIN 934-8 ● Washer 5,3 DIN 125-ST

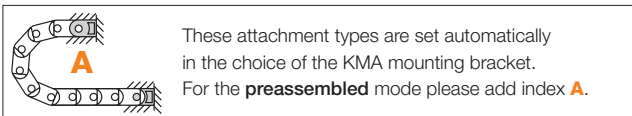

Part No. structure

**15800.100.12 A**

A... must be indicated on preassembled configurations

Full set pivoting = 12

Width index

Mounting bracket for selected width index



**Strain relief** e.g. clamps, tiwrap plates, nuggets and plug-in clips are available from stock. The complete chainfix range with order options ▶ from page 630

KMA mounting brackets, abbreviated | Attachment on all sides | pivoting | locking

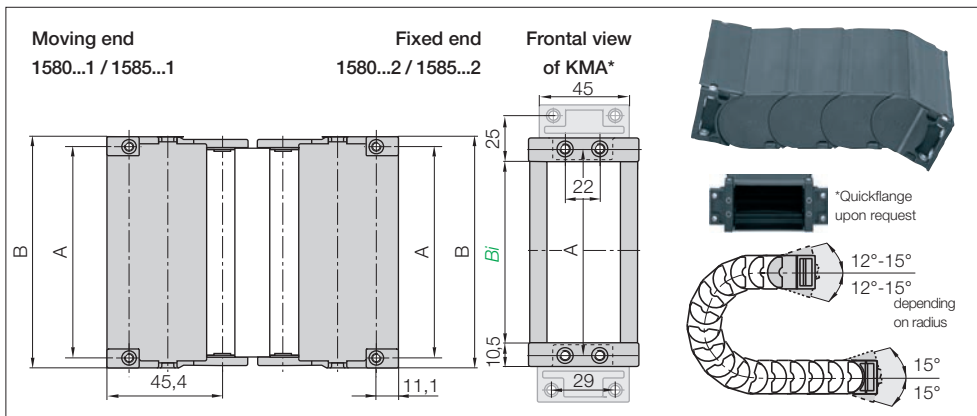

**KMA, abbreviated pivoting** | Recommended for short travels | Standard

**KMA, abbreviated locking** | Recommended for vertical hanging, standing applications

Width Index	Part No. full set <b>KMA pivoting:</b>	Part No. full set <b>KMA locking:</b>	Dim A [mm]	Dim B [mm]
.040. ▶	1580.040.12	1585.040.12	50	61
.050. ▶	1580.050.12	1585.050.12	60	71
.075. ▶	1580.075.12	1585.075.12	85	96
.088. ▶	1580.088.12	1585.088.12	98	109
.090. ▶	1580.090.12	1585.090.12	98	109
.100. ▶	1580.100.12	1585.100.12	110	121
.125. ▶	1580.125.12	1585.125.12	135	146
.135. ▶	1580.135.12	1585.135.12	145	156
.150. ▶	1580.150.12	1585.150.12	160	171
.175. ▶	1580.175.12	1585.175.12	185	196
.200. ▶	1580.200.12	1585.200.12	210	221

Full set with assembled Quickflange, please add index **QF** ▶ e.g. **1580.200.12.QF**. Quickflange unassembled: **Part No. 15800.QF**

(KMA = Polymer Metal Mounting Bracket)

The following parts are required for attachment of the mounting brackets:

- Socket head cap bolt M5 DIN 912-8.8 Length depends on the thickness of the attachment base
- Hexagon nut M5 DIN 934-8 ● Washer 5,3 DIN 125-ST

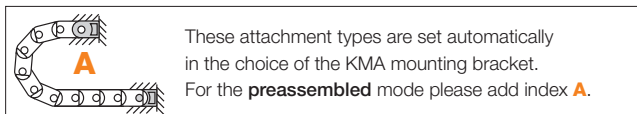

Part No. structure

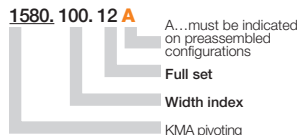

**Strain relief** e.g. clamps, tiewrap plates, nuggets and plug-in clips are available from stock. The complete chainfix range with order options ▶ from page 630

# E2 e-tubes R100 | R157·R158 | Accessories

## Mounting brackets, flange steel | locking

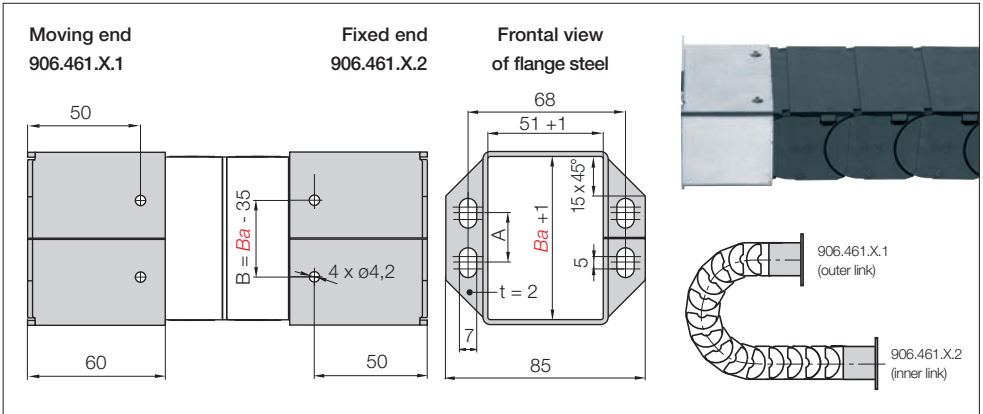

### Flange steel, pivoting | Recommended for short travels

Width Index	Hole pattern	Part No. full set steel, flange	Bi [mm]	Ba [mm]	Dim A [mm]	Dim B [mm]
.050. ▶	58.05	906.461.1.12	50	66	20	31
.075. ▶	58.1	906.461.2.12	75	91	30	57

Mounting only with hexagon socket DIN 912 M6 and washer DIN 125, 6,3 mm

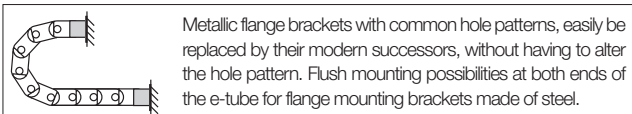

Flange steel mounting brackets for E2 e-tubes

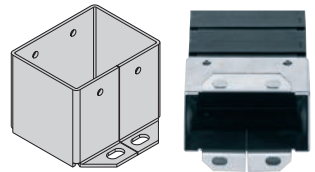

 **Strain relief** e.g. clamps, tie-wrap plates, nuggets and plug-in clips are available from stock. The complete chainfix range with order options ▶ from page 630



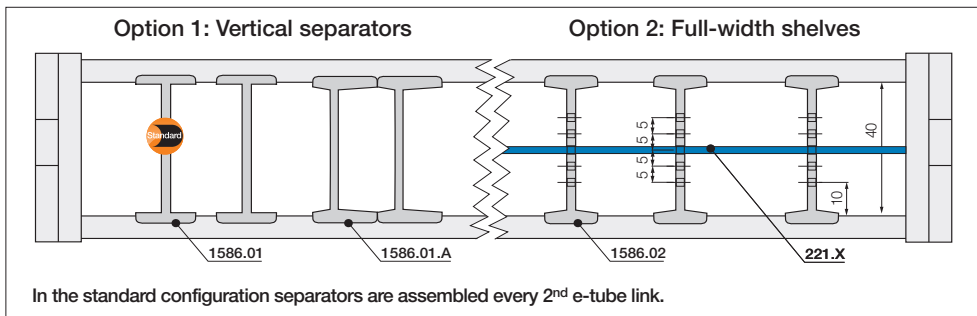

**Separator for e-tubes**

unassembled **1585.01**  
assembled **1586.01**

### Separator 1585.01

For a vertical subdivision.

Offers safe stability due to its wide base design, also when used with thick cables or hoses.

**Asymmetrical separator**

unassembled **1585.01.A**  
assembled **1586.01.A**

### Asymmetrical separator 1585.01.A

For side-mounted applications.

Asymmetrical separator, for defined distance. No additional spacers necessary.

**Separator, slotted for e-tubes**

unassembled **1585.02**  
assembled **1586.02**

### Slotted separator 1585.02

is used when vertical and horizontal separation is required. Due to its slot, it allows basic vertical/horizontal shelving arrangements.

**Full-width shelf for e-tubes**

unassembled **220.X**  
assembled **221.X**

### Full-width shelf 220.X

This option makes sense in applications with many thin cables with similar diameters. Full-width shelves can be arranged at 5 different heights (in 5 mm increments).

### Full-width shelf

Width X [mm]	unassembled	assembled	Width X [mm]	unassembled	assembled	Width X [mm]	unassembled	assembled
040	220.40	221.40	100	220.100	221.100	175	220.175	221.175
050	220.50	221.50	125	220.125	221.125	200	220.200	221.200
075	220.75	221.75	135	220.135	221.135			
088	220.88	221.88	150	220.150	221.150			

Option 3: Shelves

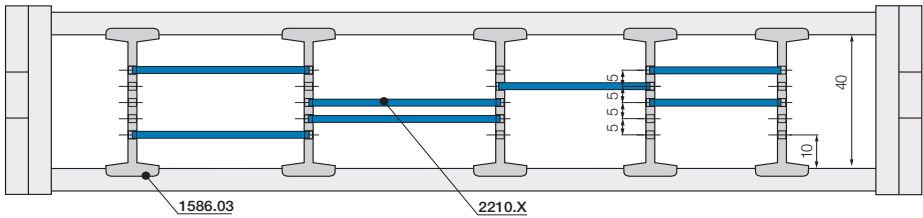

In the standard configuration separators are assembled every 2<sup>nd</sup> e-tube link.

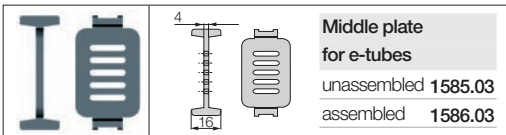

**Middle plate for e-tubes**  
unassembled 1585.03  
assembled 1586.03

**Middle plate 1585.03**

To achieve a modular shelving the shelf 2200.X can be arranged at 5 different heights (in 5 mm increments).

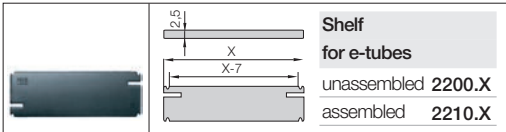

**Shelf for e-tubes**  
unassembled 2200.X  
assembled 2210.X

**Shelf 2200.X**

For applications involving many cables with different diameters, shelves can be arranged at alternate heights. They can be arranged at 5 different heights (in 5 mm increments).

**Shelves**

Width X [mm]	unassembled	assembled	Width X [mm]	unassembled	assembled	Width X [mm]	unassembled	assembled
018	2200.18	2210.18	043	2200.43	2210.43	088	2200.88	2210.88
023	2200.23	2210.23	048	2200.48	2210.48	099	2200.99	2210.99
028	2200.28	2210.28	058	2200.58	2210.58	124	2200.124	2210.124
033	2200.33	2210.33	068	2200.68	2210.68	149	2200.149	2210.149
038	2200.38	2210.38	073	2200.73	2210.73			

### Separator with integrated strain relief

Strain relief separator Part No. 1585.01.Z can be integrated into the mounting bracket and can be placed there at any point of the e-chain\*. It combines strain relief and interior separation, it can be installed on the first or last chain link and is easy to assemble without any screws. **Further Information ► from page 650**

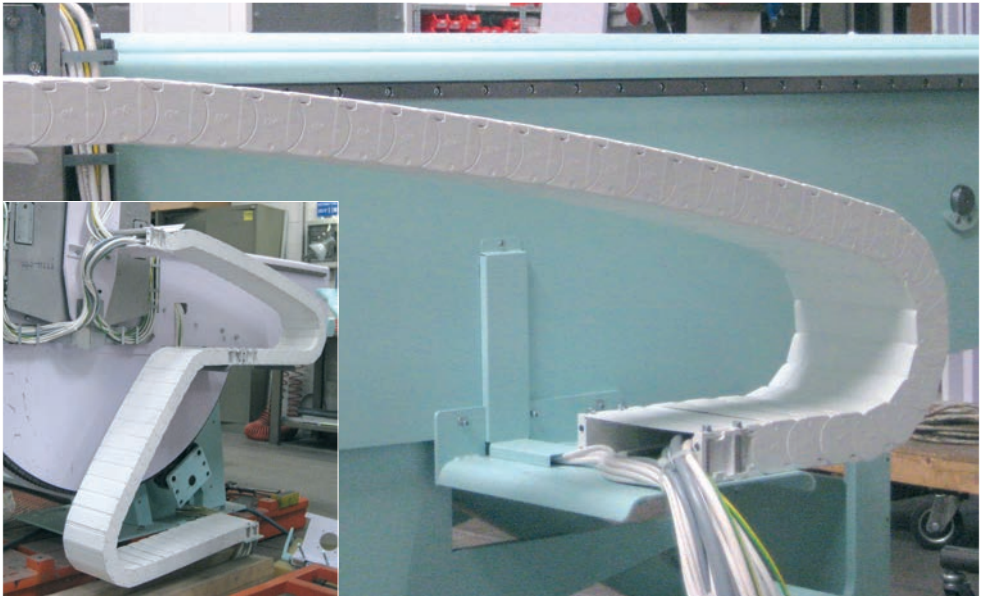

igus® white e-tubes Series R100 in a medical application



Series R167 | Hinged, snap-open on both sides of the inner radius

Series R168 | Hinged, snap-open on both sides of the outer radius | Standard

e-tubes snap-open along inner radius	e-tubes snap-open along outer radius 	<i>B<sub>i</sub></i> [mm]	<i>B<sub>a</sub></i> [mm]	<i>R</i> Bending radii [mm]								R167 [kg/m]	R168 [kg/m]
167.050. <i>R.0</i>	168.050. <i>R.0</i>	50	68	100	125	150	175	200	225	250	300	≈ 1,58	≈ 1,58
167.075. <i>R.0</i>	168.075. <i>R.0</i>	75	93	100	125	150	175	200	225	250	300	≈ 1,84	≈ 1,84
167.100. <i>R.0</i>	168.100. <i>R.0</i>	100	118	100	125	150	175	200	225	250	300	≈ 2,09	≈ 2,09
167.115. <i>R.0</i>	168.115. <i>R.0</i>	115	133	100	125	150	175	200	225	250	300	≈ 2,24	≈ 2,24
167.125. <i>R.0</i>	168.125. <i>R.0</i> *	125	143	100	125	150	175	200	225	250	300	≈ 2,35	≈ 2,35
167.150. <i>R.0</i>	168.150. <i>R.0</i>	150	168	100	125	150	175	200	225	250	300	≈ 2,60	≈ 2,60
167.175. <i>R.0</i>	168.175. <i>R.0</i>	175	193	100	125	150	175	200	225	250	300	≈ 2,86	≈ 2,86
167.200. <i>R.0</i>	168.200. <i>R.0</i>	200	218	100	125	150	175	200	225	250	300	≈ 3,11	≈ 3,11
167.225. <i>R.0</i>	168.225. <i>R.0</i> *	225	243	100	125	150	175	200	225	250	300	≈ 3,37	≈ 3,37
167.250. <i>R.0</i>	168.250. <i>R.0</i> *	250	268	100	125	150	175	200	225	250	300	≈ 3,62	≈ 3,62

\*Width available upon request, please consult igus\* for delivery time

Supplement Part No. with required radius. Example: 168.100.100.0

### Hot Chips up to 850°C

e-tubes that repel hot chips, up to 850 °C. Some applications, depending on amount and size of the chips, can burn or melt the surface. That is no longer the case with the igus® "igumid HT" material. Order example: Full e-tube made of igumid HT:

Part No. 168.100.100.0.HT (for long travels upon request)

Delivery time upon request. Further Information ► [www.igus.eu/eu/HT](http://www.igus.eu/eu/HT)

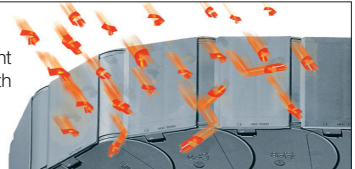



## Unsupported applications | Short travels

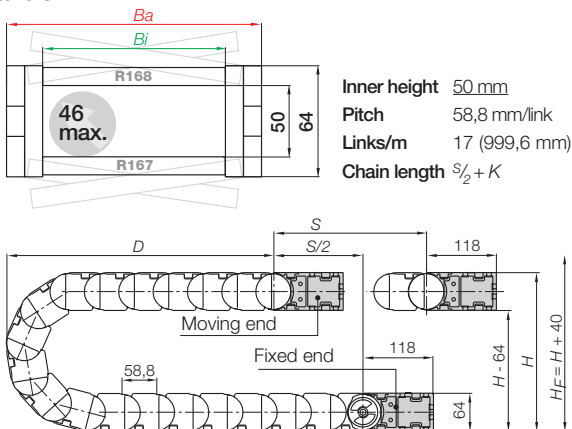
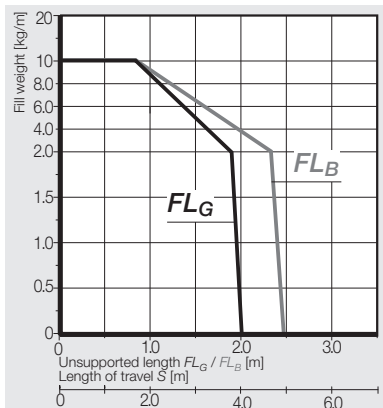

Inner height 50 mm  
Pitch 58,8 mm/link  
Links/m 17 (999,6 mm)  
Chain length  $\frac{S}{2} + K$

R	100	125	150	175	200	225	250	300
H	264	314	364	414	464	514	564	664
D	220	245	270	295	320	345	370	420
K	435	515	590	670	750	825	905	1065

The required clearance height:  $H_F = H + 40$  mm (with 2,0 kg/m fill weight)

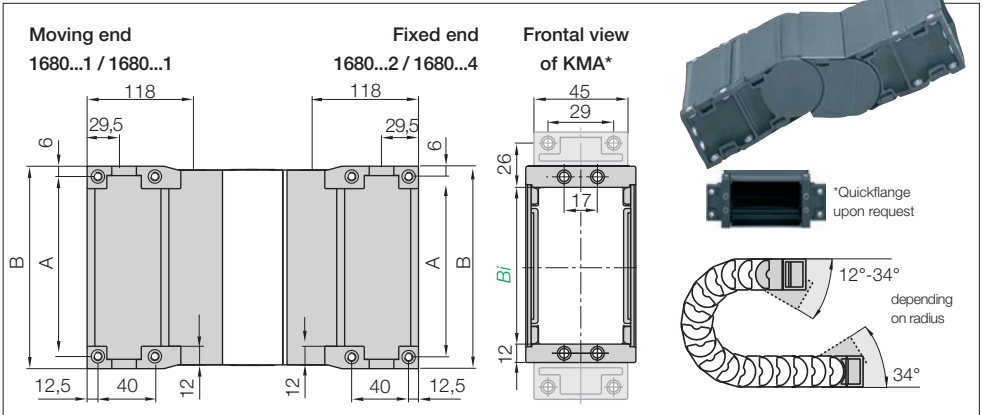

**KMA, pivoting** | Recommended for short travels | Standard

**KMA, locking** | Recommended for vertical hanging, standing applications

Width Index	 Part No. full set <b>KMA pivoting:</b>	Part No. full set <b>KMA locking:</b>	Dim A [mm]	Dim B [mm]
.050. ▶	1680.050.12	1680.050.14	62	74
.075. ▶	1680.075.12	1680.075.14	87	99
.100. ▶	1680.100.12	1680.100.14	112	124
.115. ▶	1680.115.12	1680.115.14	127	139
.125. ▶	1680.125.12	1680.125.14	137	149
.150. ▶	1680.150.12	1680.150.14	162	174
.175. ▶	1680.175.12	1680.175.14	187	199
.200. ▶	1680.200.12	1680.200.14	212	224
.225. ▶	1680.225.12	1680.225.14	237	249
.250. ▶	1680.250.12	1680.250.14	262	274

Full set with assembled Quickflange, please add index **QF** ▶ e.g. **1680.250.12.QF**. Quickflange unassembled: **Part No. 16800.QF**

(KMA = Polymer Metal Mounting Bracket)

The following parts are required for attachment of the mounting brackets:

- Socket head cap bolt M5 DIN 912-8.8 Length depends on the thickness of the attachment base
- Washer 5,3 DIN 125-ST ● Hexagon nut M5 DIN 934-8

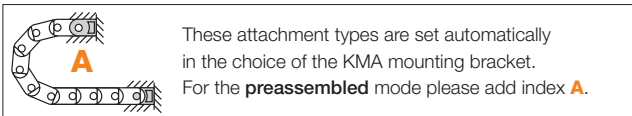

**Part No. structure**

**1680.100.12 A**

A...must be indicated on preassembled configurations

Full set pivoting = 12

Width index  
Mounting bracket for selected width index



**Strain relief** e.g. clamps, tiewrap plates, nuggets and plug-in clips are available from stock. The complete chainfix range with order options ▶ from page 630

## Mounting brackets, flange steel | locking

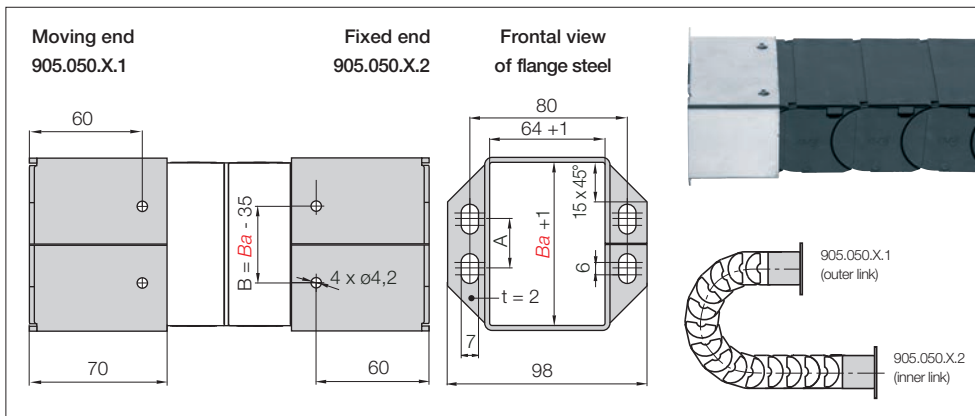

## Flange steel, pivoting | Recommended for short travels

Width Index	Hole pattern	Part No. full set steel, flange	<i>Bi</i> [mm]	<i>Ba</i> [mm]	Dim A [mm]	Dim B [mm]
.075. ▶	68.01	905.050.1.12	75	93	30	58
.115. ▶	68.02	905.050.2.12	115	133	50	98
.175. ▶	68.03	905.050.3.12	175	193	100	158

Mounting only with hexagon socket DIN 912 M6 and washer DIN 125, 6,3 mm

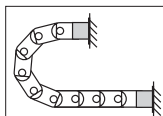

Metallic flange brackets with common hole patterns, easily be replaced by their modern successors, without having to alter the hole pattern. Flush mounting possibilities at both ends of the e-tube for flange mounting brackets made of steel.

Flange steel mounting brackets for E2 e-tubes

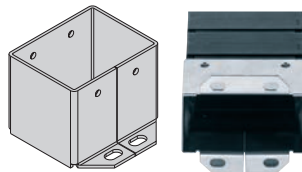

**Strain relief** e.g. clamps, tie-wrap plates, nuggets and plug-in clips are available from stock. The complete chainfix range with order options ▶ from page 630

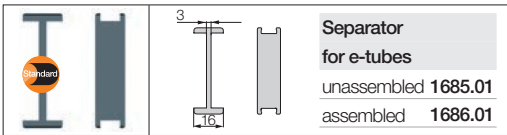
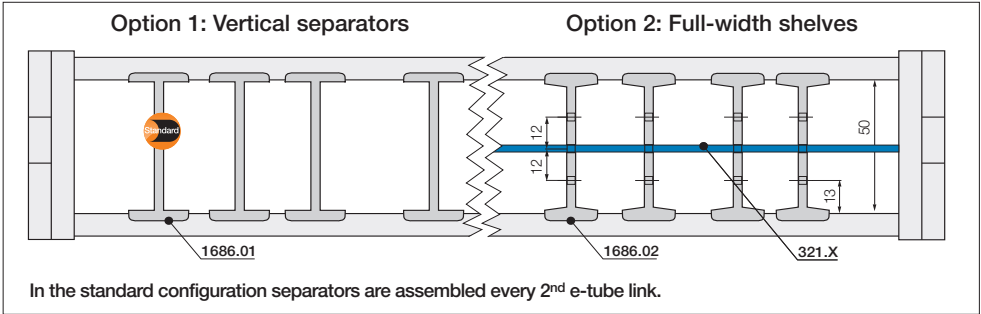

### Separator 1685.01

For a vertical subdivision.

Offers safe stability due to its wide base design, also when used with thick cables or hoses.

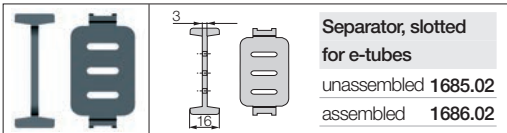

### Slotted separator 1685.02

is used when vertical and horizontal separation is required. Due to its slot, it allows basic vertical/horizontal shelving arrangements.

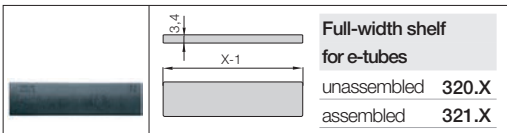

### Full-width shelf 320.X

This option makes sense in applications with many thin cables with similar diameters. Full-width shelves can be arranged at 3 different heights (in 12 mm increments).

### Full-width shelf

Width X [mm]	unassembled	assembled	Width X [mm]	unassembled	assembled	Width X [mm]	unassembled	assembled
050	320.050	321.050	125	320.125	321.125	225	320.225	321.225
075	320.075	321.075	150	320.150	321.150	250	320.250	321.250
100	320.100	321.100	175	320.175	321.175			
115	320.115	321.115	200	320.200	321.200			



## Interior separation | Option 3

### Option 3: Shelves

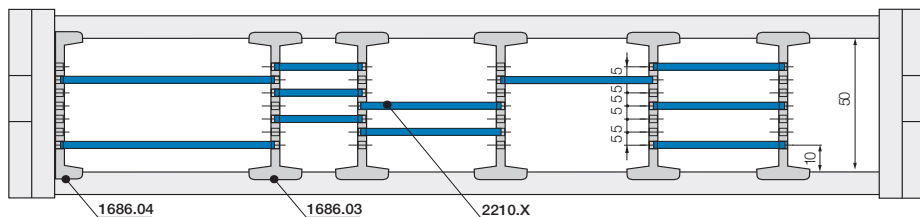

In the standard configuration separators are assembled every 2<sup>nd</sup> e-tube link.

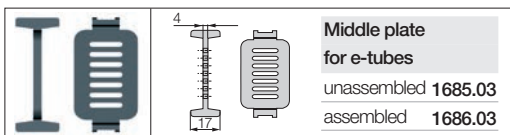

#### Middle plate for e-tubes

unassembled **1685.03**

assembled **1686.03**

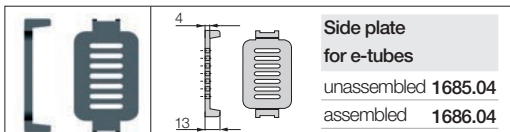

#### Side plate for e-tubes

unassembled **1685.04**

assembled **1686.04**

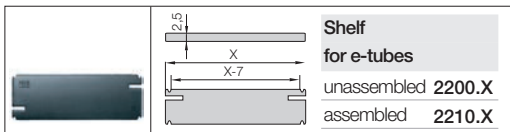

#### Shelf for e-tubes

unassembled **2200.X**

assembled **2210.X**

### Middle plate 1685.03

To achieve a modular shelving the shelf 2200.X can be arranged at 7 different heights (in 5 mm increments).

### Side plate 1685.04

Side plate for use with shelf 2200.X and middle plate 1685.03.

### Shelf 2200.X

For applications involving many cables with different diameters, shelves can be arranged at alternate heights. They can be arranged at 7 different heights (in 5 mm increments).

## Shelves

Width X [mm]	unassembled	assembled	Width X [mm]	unassembled	assembled	Width X [mm]	unassembled	assembled
018	2200.18	2210.18	043	2200.43	2210.43	088	2200.88	2210.88
023	2200.23	2210.23	048	2200.48	2210.48	099	2200.99	2210.99
028	2200.28	2210.28	058	2200.58	2210.58	124	2200.124	2210.124
033	2200.33	2210.33	068	2200.68	2210.68	149	2200.149	2210.149
038	2200.38	2210.38	073	2200.73	2210.73			

### Separator with integrated strain relief

Strain relief separator Part No. **1685.01.Z** can be integrated into the mounting bracket and can be placed there at any point of the e-chain®. It combines strain relief and interior separation, it can be installed on the first or last chain link and is easy to assemble without any screws. **Further Information ► from page 650**

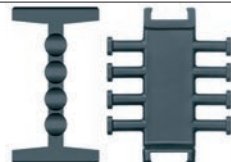

Universal:  
Attachment on all sides

Chip protection:  
Smooth, chip-  
repellent exterior

Quick assembly:  
Removable lids  
along outer radius

Long service life:  
Large pins for  
high stability

Quiet:  
Small pitch for low-noise,  
smooth operation

Long service life:  
Double stop dog for  
strong unsupported length



**iF produkt design award**  
1987 igus® Series R68

## E2 Series R - chip protection - higher speeds and smooth running

E2 Series R - small pitch for higher speeds and smooth motion. igus® e-tubes work in hot chip areas, in areas of dirt and dust generated by woodworking, steelmills, pulp and paper, textile, agriculture, coal plant and many other hostile environments.

- Very good protection against chips (including hot chips)
- Robust and tight
- Space-efficient with optimized ratio of inner dimension to outer dimension
- Modular interior separation
- Universal KMA mounting brackets with attachment options on all sides

### Typical industries and applications

- Tooling machines
- Woodworking machines
- All kind of industries and machines with chip, dirt and dust



e-tubes with igumid HT-Material for hot chips up to 850°C available upon request



Electrically conductive  
ESD/ATEX versions upon request



UL94-V0 classification  
upon request



# E2 e-tubes R | Selection Table

Series	Inner height <i>hi</i> [mm]	Inner width <i>Bi</i> [mm]	Outer width <i>Ba</i> [mm]	Outer height <i>ha</i> [mm]	Bending radius <i>R</i> [mm]	Unsupported max. length [m]	Page
--------	--------------------------------	-------------------------------	-------------------------------	--------------------------------	---------------------------------	--------------------------------	------



**E2 e-tubes R -**  
Removable lids  
along outer radius

<b>R48</b>	25	25 - 130	36 - 141	36	60 - 250	1,50	<b>324</b>
<b>R58</b>	35	50 - 200	66 - 216	50	75 - 250	2,30	<b>330</b>
<b>R68</b>	45	50 - 250	68 - 268	64	100 - 300	2,50	<b>336</b>



E2 e-tubes in chip-area of a tooling machine. Resistant against hot metal chips up to 850°C

## Technical Data



Gliding <sup>1)</sup> speed / acceleration (maximum) max. 3 [m/s] / max. 10 [m/s<sup>2</sup>]

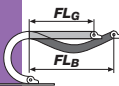

Speed / acceleration  $FL_G$  max. max. 10 [m/s] / max. 100 [m/s<sup>2</sup>]

Speed / acceleration  $FL_B$  max. max. 3 [m/s] / max. 6 [m/s<sup>2</sup>]



Material - permitted temperature °C, igumid G / GLW -40° up to +100° C









Flammability class, igumid G / GLW VDE 0304 IIC UL94-HB

■  $FL_G$  = with straight upper run ■  $FL_B$  = with permitted sag

1) For gliding applications, please consult igus\*.









## Installation methods overview, maximum travels

e-chain® / e-tube Series	 Unsupported application	 Gliding application <sup>1)</sup>	 Vertical hanging	 Vertical standing	 Side mounted unsupported	 Zig-zag application	 Unsupp. length of lower run
R48	≤ 1,30 m	≤ 50 m	≤ 50 m	≤ 4,0 m	≤ 1,5 m	upon request	upon request
R58	≤ 2,30 m	≤ 75 m	≤ 50 m	≤ 4,0 m	≤ 2,0 m	upon request	upon request
R68	≤ 2,50 m	≤ 100 m	≤ 60 m	≤ 4,0 m	≤ 2,0 m	upon request	upon request

1) For gliding applications, please consult igus\*.

# E2 e-tubes R | Order keys and Options

## Options with order keys based on Series R58

 <b>Standard</b>  Part No. <b>Standard</b> e-tubes 	NC-Version - (no camber) without pretension  Part No. <b>NC-Version</b> e-tubes 	No burning-in of hot chips up to 850°C (1562°F)  Part No. <b>igumid HT-Material</b> only for e-tubes 	ESD / ATEX classified e-chains®   Part No. <b>ESD-Material</b> e-tubes 
 <b>58.100.R.0</b>	<b>58.100.R.0.NC</b>	<b>58.100.R.0.HT</b>	<b>58.100.R.0.ESD</b>
 <b>Delivery from stock</b>	<b>Delivery time: upon request</b>	<b>Delivery time: upon request</b>	<b>Delivery time: upon request</b>

## Order example | Order key and color options based on Series R58

 **Order example for complete e-tube (1,0 m), color black, with mounting brackets and interior separation:**





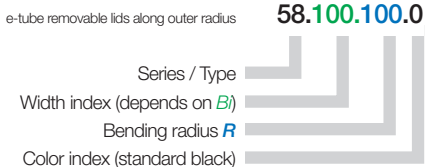





e-tube (1,0 m)	Please indicate e-tube length or number of links: 1,0 m or 56 links	<b>58.100.100.0</b>
+ Mounting brackets	KMA, pivoting - 1set	<b>580.100.12</b>
+ Interior separation	with 2 separators assembled every 2 <sup>nd</sup> link	<b>2 x 582</b>
Order text: 1,0 m <b>58.100.100.0</b> + <b>580.100.12</b> + 2 x <b>582</b>		

### Order key



**58.100.100.0** = e-tube snap-open on both sides of the outer radius, inner width *B* 100 mm, radius *R* 100 mm, color black

### General igus® color options for e-chains® and e-tubes

Color	Order index	Color	Order index
 <b>Black</b> Standard, from stock!	<b>.0</b>	 <b>White</b> special color	<b>.1</b>
 <b>Slate grey</b> only ESD material	<b>.ESD</b>	 <b>Gray white</b> special color	<b>.1S</b>
 <b>Gray brown</b> only HT material	<b>.HT</b>	 <b>Orange</b> special color	<b>.2</b>
 <b>Gray</b> special color only e-chains®	<b>.3</b>	 <b>Yellow</b> special color	<b>.4</b>
 <b>Dusty grey</b> special color only e-tubes	<b>.31</b>	 <b>Light grey</b> special color	<b>.14</b>

**Black e-chains® available from stock!**  
**Delivery time for special colors: upon request**

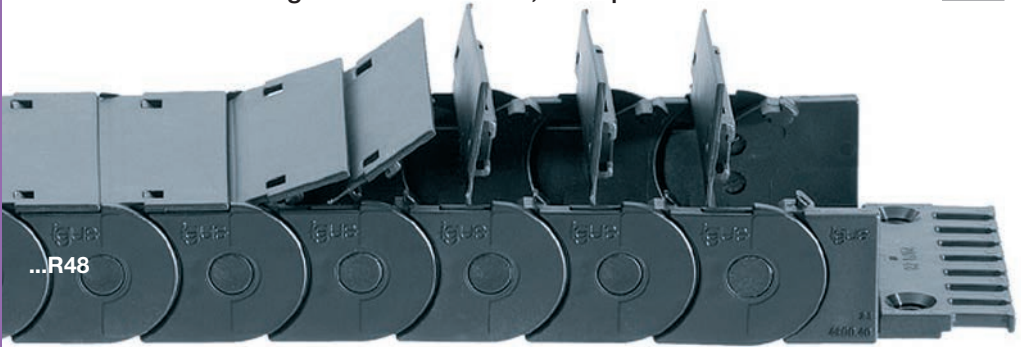

## Series R48 | Removable lids along outer radius

Removable lids along outer radius	<i>Bi</i> [mm]	<i>Ba</i> [mm]	<i>R</i> Bending radii [mm]										Weight [kg/m]
48.025 .R.0	25	36	060	075	100	125	150	175	200	250	≈ 0,64		
48.050 .R.0	50	61	060	075	100	125	150	175	200	250	≈ 0,84		
48.075 .R.0	75	86	060	075	100	125	150	175	200	250	≈ 1,03		
48.100 .R.0	100	111	060	075	100	125	150	175	200	250	≈ 1,23		
48.130 .R.0	130	141	060	075	100	125	150	175	200	250	≈ 1,46		

Supplement Part No. with required radius. Example: 48.100.100.0

### Hot Chips up to 850°C

e-tubes that repel hot chips, up to 850 °C. Some applications, depending on amount and size of the chips, can burn or melt the surface. That is no longer the case with the igus® "igumid HT" material. Order example: Full e-tube made of igumid HT:

**Part No. 48.100.100.0.HT** (for long travels upon request)

Delivery time upon request. **Further Information** ► [www.igus.eu/HT](http://www.igus.eu/HT)

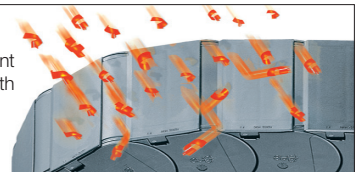



## Unsupported applications | Short travels

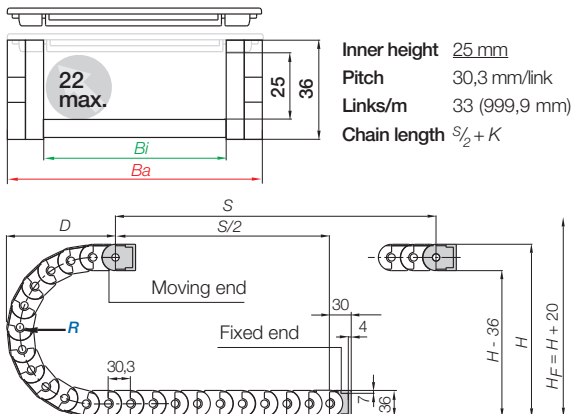
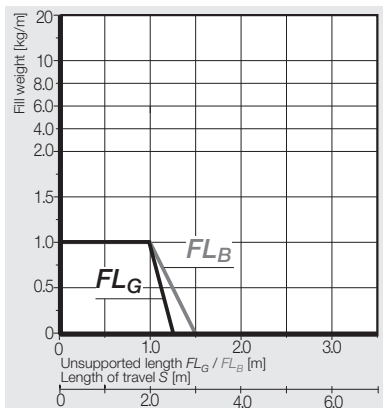

R	060	075	100	125	150	175	200	250
H	156	186	236	286	336	386	436	536
D	123	138	163	188	213	238	263	313
K	250	300	375	455	535	615	690	850

The required clearance height:  $H_F = H + 20$  mm (with 0,5 kg/m fill weight)

## Gliding<sup>1)</sup> applications | Long travels from 5 m to max. 50 m

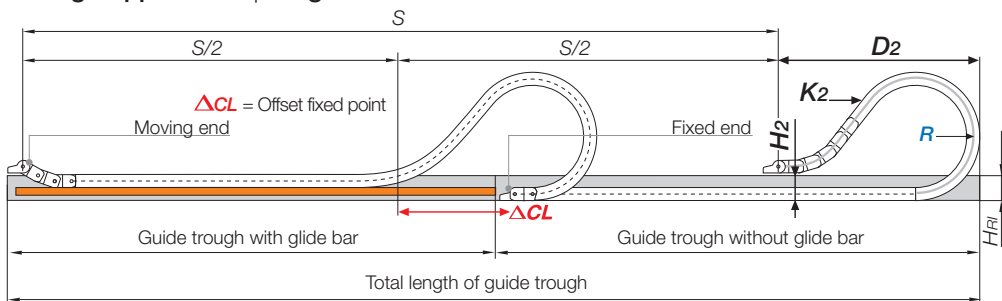

**Note:** For long travel applications with more than 100 m we recommend to realize the engineering of such a plant by our technicians. In case of travels between 2 and 5 m we recommend a longer unsupported length. **Chain length**  $S/2 + K_2$

<sup>1)</sup> For gliding applications, please consult igus\*.

R	060	075	100	125	150	175	200	250
H <sub>2</sub>	156	186	176	176	176	176	176	*
D <sub>2</sub>	110	125	330	450	610	730	690	*
K <sub>2</sub>	250	300	545	758	970	1151	1182	*
$\Delta CL$	*	*	170	270	380	470	*	*

\*Values upon request

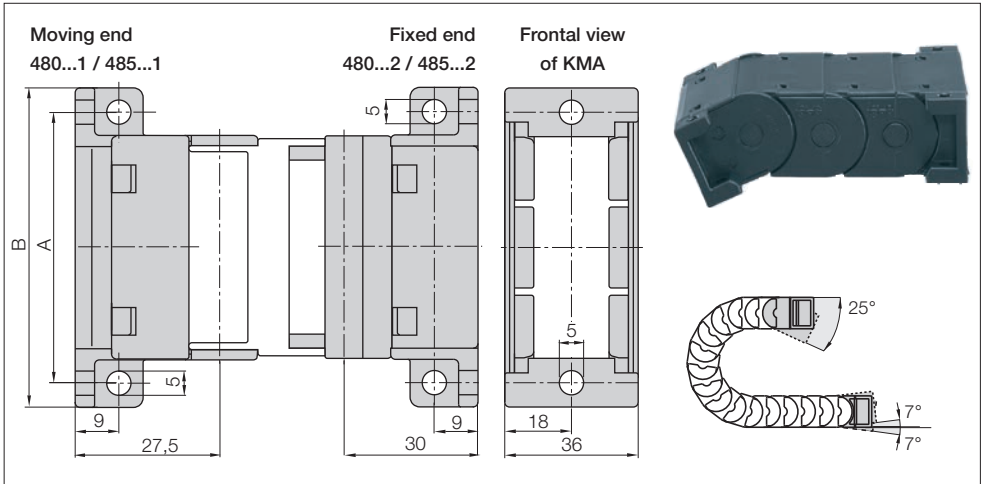

**KMA pivoting | Standard | Recommended for unsupported applications**

**KMA locking | Recommended for vertical hanging and standing applications**

Width Index	 Part No. full set <b>KMA pivoting:</b>	Part No. full set <b>KMA locking:</b>	Dim A [mm]	Dim B [mm]
.025. ▶	<b>480.025.12</b>	<b>485.025.12</b>	45	55
.050. ▶	<b>480.050.12</b>	<b>485.050.12</b>	70	80
.075. ▶	<b>480.075.12</b>	<b>485.075.12</b>	95	105
.100. ▶	<b>480.100.12</b>	<b>485.100.12</b>	120	130
.130. ▶	<b>480.130.12</b>	<b>485.130.12</b>	150	160

(KMA = Polymer Metal Mounting Bracket)

The following parts are required for attachment of the mounting brackets:

- Socket head cap bolt M5 DIN 912-8.8 Length depends on the thickness of the attachment base
- Hexagon nut M5 DIN 934-8 ● Washer 5,3 DIN 125-ST

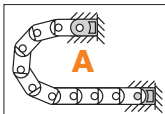

These attachment types are set automatically in the choice of the KMA mounting bracket.  
For the **preassembled** mode please add index **A**.

**Part No. structure**

**480. 100. 12 A**

A...must be indicated on preassembled configurations

**Full set** with strain relief tiwrap plates

**Width index**

KMA pivoting



**Strain relief** e.g. clamps, tiwrap plates, nuggets and plug-in clips are available from stock. The complete chainfix range with order options ▶ from page 630



# E2 e-tubes R | Series R48 | Accessories

## Mounting brackets, angled, polymer | one side pivoting

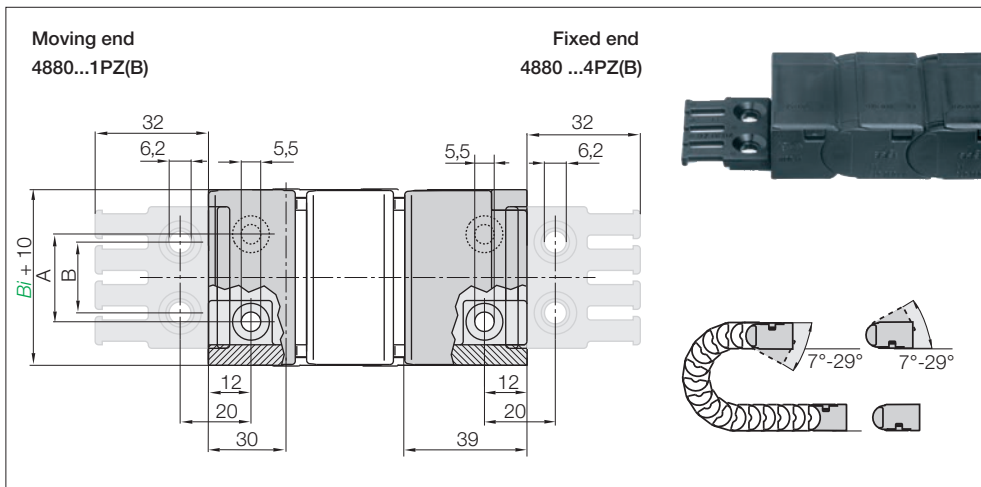

### Angled polymer bracket | one side pivoting

#### Recommended for short and long travels

Width Index	Part No. full set <b>with</b> tiewrap plates	Part No. full set <b>without</b> tiewrap plates	Dim A [mm]	Dim B [mm]	Number of teeth
.025. ▶	4800.025.12PZB	4800.025.12	12	15	3
.050. ▶	4800.050.12PZB	4800.050.12	37	30	5
.075. ▶	4800.075.12PZB	4800.075.12	62	60	8
.100. ▶	4800.100.12PZB	4800.100.12	87	80	10
.130. ▶	-	4800.130.12	117	-	-

The following parts are required for attachment of the mounting brackets:

- Countersunk bolt M5 DIN 912-8.8 Length depends on the thickness of the attachment base
- Hexagon nut M5 DIN 934-8

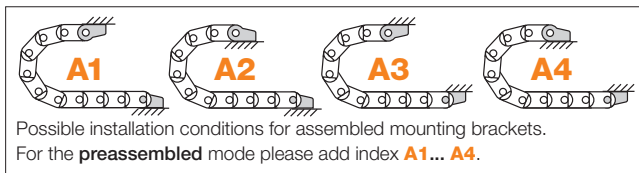

#### Part No. structure

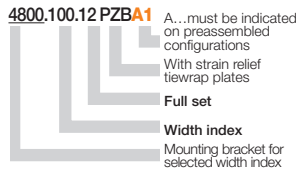

 **Strain relief** e.g. clamps, tiewrap plates, nuggets and plug-in clips are available from stock. The complete chainfix range with order options ▶ from page 630

# E2 e-tubes R | Series R48 | Accessories

## Mounting brackets, steel | one side pivoting

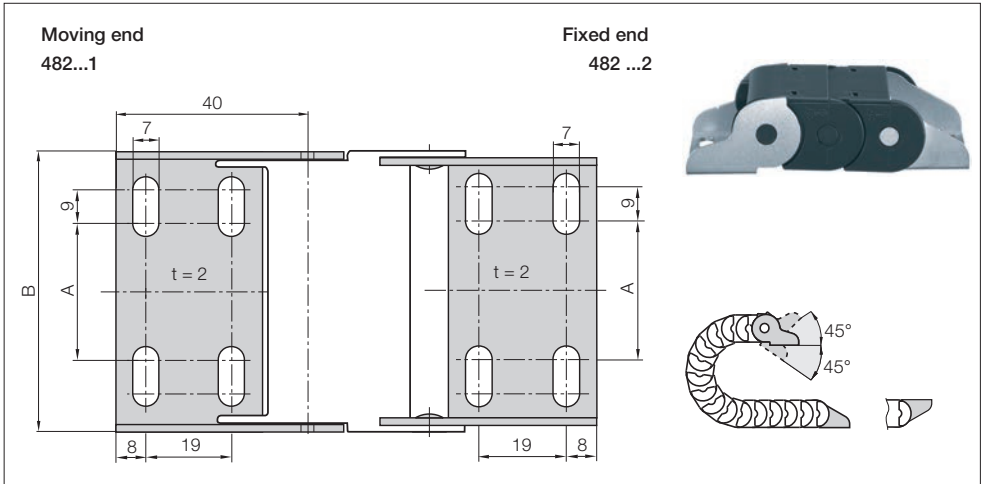

### Steel pivoting | one side pivoting

Recommended for unsupported, vertical hanging, standing applications

Width Index	Part No. full set Steel on side pivoting:	Dim A [mm]	Dim B [mm]
.025. ▶	482.025 .12	–	35
.050. ▶	482.050 .12	22	60
.075. ▶	482.075 .12	47	85
.100. ▶	482.100 .12	72	110
.130. ▶	482.130 .12	102	140

The following parts are required for attachment of the mounting brackets:

- Socket head cap bolt M5 DIN 912-8.8 Length depends on the thickness of the attachment base
- Hexagon nut M5 DIN 934-8 ● Washer 5,3 DIN 125-ST

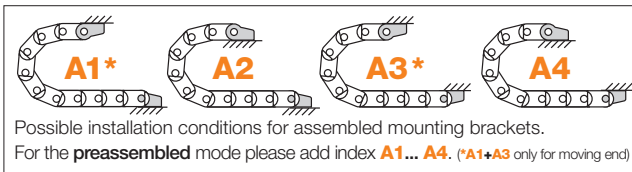

### Part No. structure

482. 100. 12 **A1**

A...must be indicated on preassembled configurations

Full set with strain relief tiewrap plates

Width index

Mounting bracket for selected width index



**Strain relief** e.g. clamps, tiewrap plates, nuggets and plug-in clips are available from stock. The complete chainfix range with order options ▶ from page 630

Interior separation

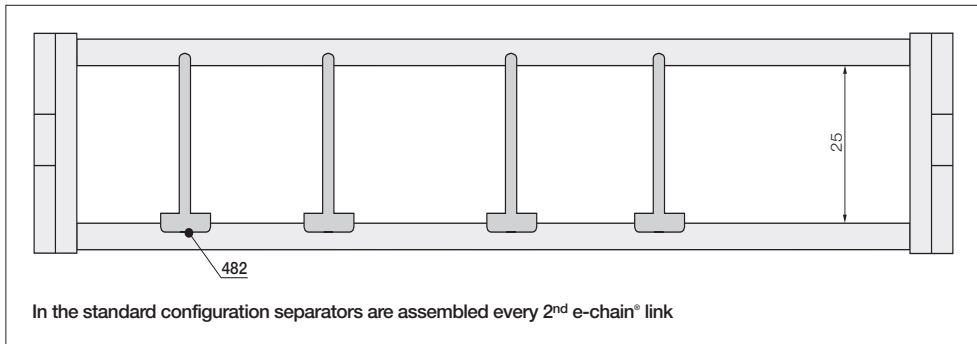

Separator for e-tubes	
unassembled	481
assembled	482

**Separator 481**

Vertical Separators are used if a vertical subdivision of the e-tube interior is required - By standard Vertical Separators are assembled every other e-tube link.

**Separator with integrated strain relief**

Strain relief separator Part No. 481.ZR can be integrated into the mounting bracket and can be placed there at any point of the e-chain®. It combines strain relief and interior separation, it can be installed on the first or last chain link and is easy to assemble without any screws. **Further Information ► from page 650**





## Series R58 | Removable lids along outer radius

Removable lids along outer radius	<i>Bi</i> [mm]	<i>Ba</i> [mm]	<i>R</i> Bending radii [mm]	Weight [kg/m]
58.050.R.0	50	66	075   100   125   150   200   250	≈ 1,50
58.075.R.0	75	91	075   100   125   150   200   250	≈ 1,77
58.100.R.0	100	116	075   100   125   150   200   250	≈ 2,04
58.125.R.0	125	141	075   100   125   150   200   250	≈ 2,31
58.150.R.0	150	166	075   100   125   150   200   250	≈ 2,61
58.175.R.0	175	191	075   100   125   150   200   250	≈ 2,88
58.200.R.0	200	216	075   100   125   150   200   250	≈ 3,15

Supplement Part No. with required radius. Example: 58.100.100.0

### Hot Chips up to 850°C

e-tubes that repel hot chips, up to 850 °C. Some applications, depending on amount and size of the chips, can burn or melt the surface. That is no longer the case with the igus® "Igmuid HT" material. Order example: Full e-tube made of Igmuid HT:

Part No. 58.100.100.0.HT (for long travels upon request)

Delivery time upon request. **Further Information** ► [www.igus.eu/eu/HT](http://www.igus.eu/eu/HT)

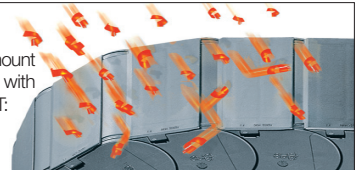



## Unsupported applications | Short travels

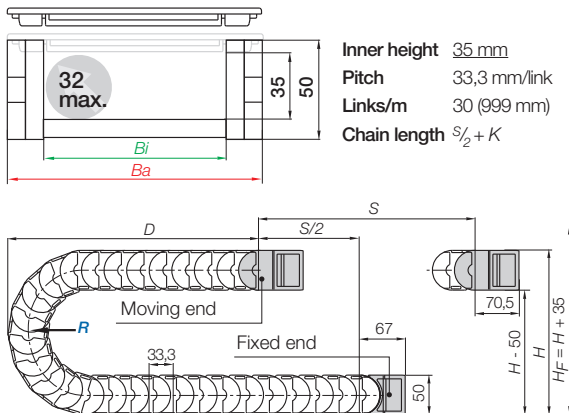
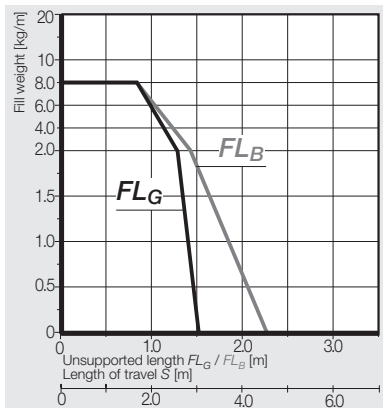

Inner height 35 mm  
 Pitch 33,3 mm/link  
 Links/m 30 (999 mm)  
 Chain length  $\frac{S}{2} + K$

R	075	100	125	150	200	250
H	200	250	300	350	450	550
D	150	175	200	225	275	325
K	305	385	460	540	695	855

The required clearance height:  $H_F = H + 35$  mm (with 0,5 kg/m fill weight)

## Gliding<sup>1)</sup> applications | Long travels from 5 m to max. 75 m

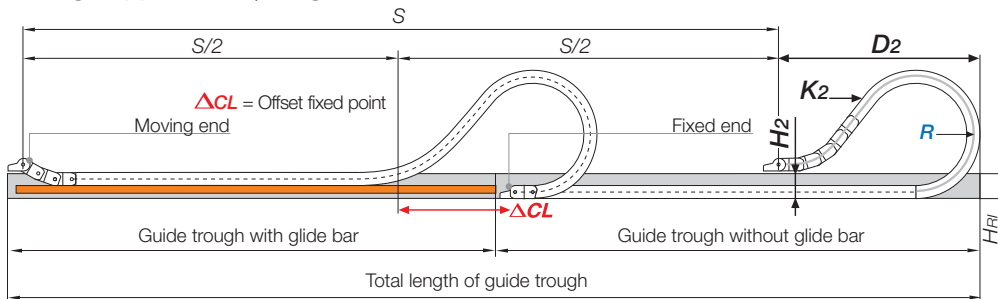

**Note:** For long travel applications with more than 100 m we recommend to realize the engineering of such a plant by our technicians. In case of travels between 3 and 5 m we recommend a longer unsupported length. **Chain length**  $\frac{S}{2} + K_2$

<sup>1)</sup> For gliding applications, please consult igus\*.

R	075	100	125	150	200	250
H <sub>2</sub>	200	216	216	216	216	216
D <sub>2</sub>	150	310	380	480	800	1050
K <sub>2</sub>	375	500	699	866	1265	1665
ΔCL	*	122	167	247	512	717

\*Values upon request

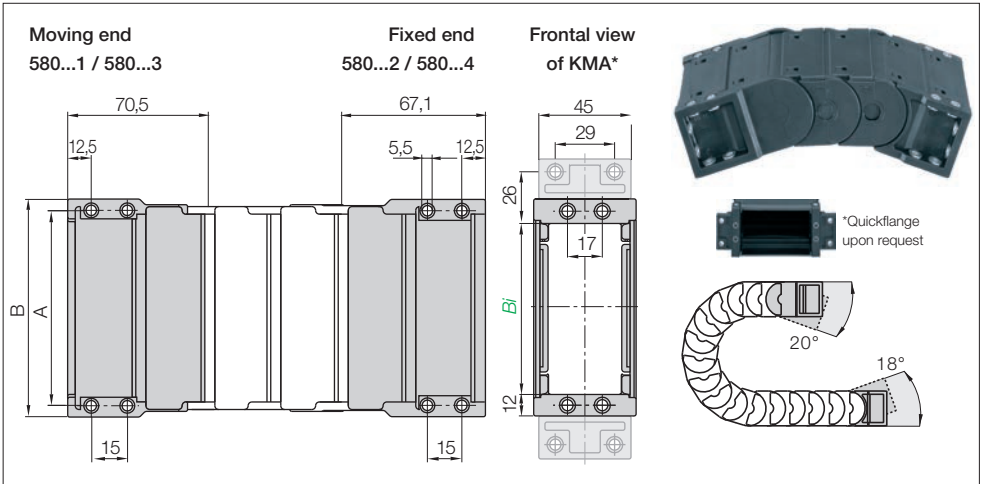

**KMA pivoting | Standard | Recommended for unsupported applications**

**KMA locking | Recommended for vertical hanging and standing applications**

Width Index	 Part No. full set <b>KMA pivoting:</b>	Part No. full set <b>KMA locking:</b>	Dim A [mm]	Dim B [mm]
.050. ▶	<b>580.050.12</b>	<b>580.050.34</b>	62	74
.075. ▶	<b>580.075.12</b>	<b>580.075.34</b>	87	99
.100. ▶	<b>580.100.12</b>	<b>580.100.34</b>	112	124
.125. ▶	<b>580.125.12</b>	<b>580.125.34</b>	137	149
.150. ▶	<b>580.150.12</b>	<b>580.150.34</b>	162	174
.175. ▶	<b>580.175.12</b>	<b>580.175.34</b>	187	199
.200. ▶	<b>580.200.12</b>	<b>580.200.34</b>	212	224

Full set with assembled Quickflange, please add index **QF** ▶ e.g. **16800.12.QF**. Quickflange unassembled: **Part No. 16800.QF**

(KMA = Polymer Metal Mounting Bracket)

The following parts are required for attachment of the mounting brackets:

- Socket head cap bolt M5 DIN 912-8.8 Length depends on the thickness of the attachment base
- Hexagon nut M5 DIN 934-8 ● Washer 5,3 DIN 125-ST

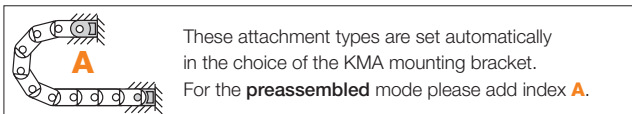

**Part No. structure**

**580. 100. 12 A**

A... must be indicated on preassembled configurations

**Full set pivoting = 12**

**Width index**

Mounting bracket for selected width index



**Strain relief** e.g. clamps, tiewrap plates, nuggets and plug-in clips are available from stock. The complete chainfix range with order options ▶ from page 630

## Mounting brackets, flange steel | pivoting

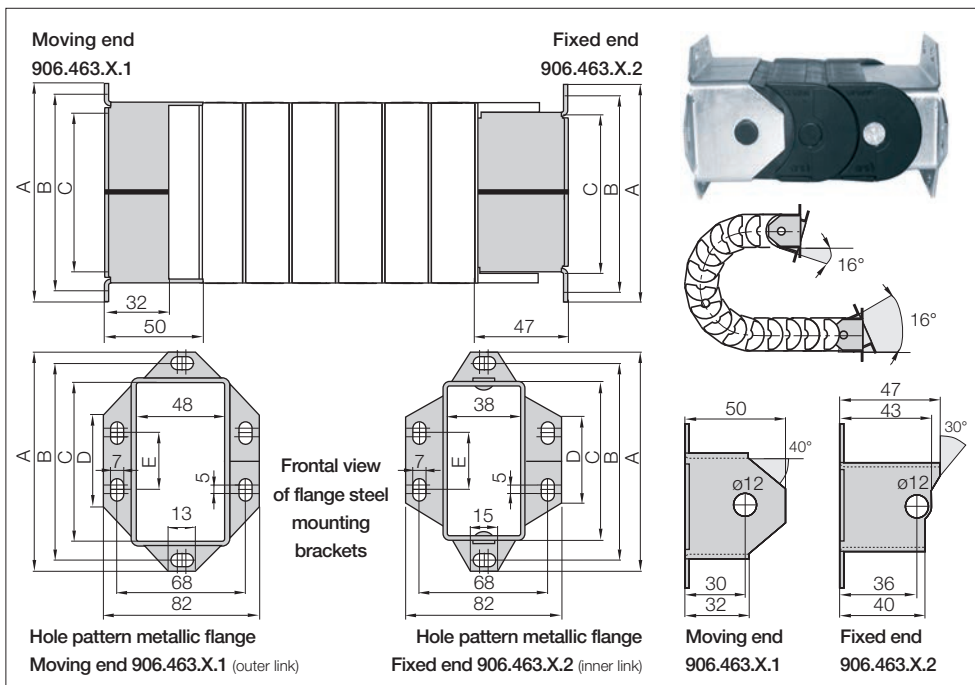

## Flange steel, pivoting | Recommended for unsupported applications

Width Index	Hole pattern	Part No. Moving end	Bi [mm]	Dim A [mm]	Dim B [mm]	Dim C [mm]	Dim D [mm]	Dim E [mm]
.050. ▶	58.05	906.463.05.1	50	90,5	78,5	58,3	24,5	20
.075. ▶	58.1	906.463.1.1	75	116	104	83,3	50	30
Width Index	Hole pattern	Part No. Fixed end	Bi [mm]	Dim A [mm]	Dim B [mm]	Dim C [mm]	Dim D [mm]	Dim E [mm]
.050. ▶	58.05	906.463.05.2	50	90,5	78,5	57,5	28	20
.075. ▶	58.1	906.463.1.2	75	116	104	82,5	45	30

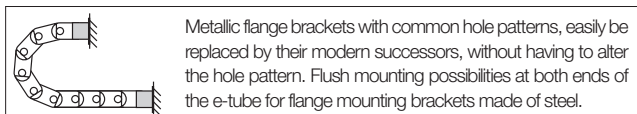

 **Strain relief** e.g. clamps, tiewrap plates, nuggets and plug-in clips are available from stock. The complete chainfix range with order options ▶ from page 630

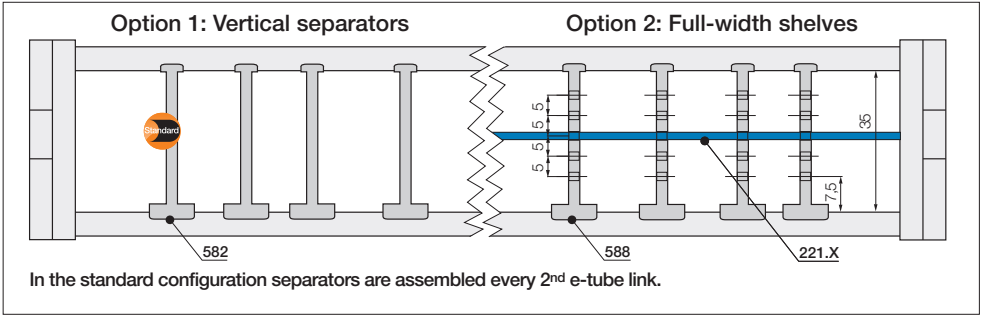

**Separator for e-tubes**

unassembled	<b>581</b>
assembled	<b>582</b>

### Separator 581

For a vertical subdivision.  
Offers safe stability due to its wide base design, also when used with thick cables or hoses.

**Separator, slotted for e-tubes**

unassembled	<b>587</b>
assembled	<b>588</b>

### Slotted separator 587

is used when vertical and horizontal separation is required. Due to its slot, it allows basic vertical/horizontal shelving arrangements.

**Full-width shelf for e-tubes**

unassembled	<b>220.X</b>
assembled	<b>221.X</b>

### Full-width shelf 220.X

This option makes sense in applications with many thin cables with similar diameters. Full-width shelves can be arranged at 5 different heights (in 5 mm increments).

### Full-width shelf

Width X [mm]	unassembled	assembled	Width X [mm]	unassembled	assembled	Width X [mm]	unassembled	assembled
050	220.50	221.50	125	220.125	221.125	200	220.200	221.200
075	220.75	221.75	150	220.150	221.150			
100	220.100	221.100	175	220.175	221.175			



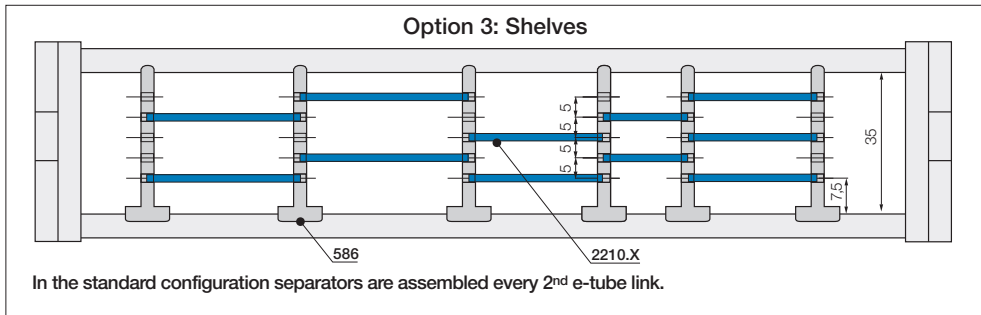

**Middle plate for e-tubes**

unassembled	<b>585</b>
assembled	<b>586</b>

### Middle plate 585

To achieve a modular shelving the shelf 2200.X can be arranged at 5 different heights (in 5 mm increments).

**Shelf for e-tubes**

unassembled	<b>2200.X</b>
assembled	<b>2210.X</b>

### Shelf 2200.X

For applications involving many cables with different diameters, shelves can be arranged at alternate heights. They can be arranged at 5 different heights (in 5 mm increments).

### Shelves

Width X [mm]	unassembled	assembled	Width X [mm]	unassembled	assembled	Width X [mm]	unassembled	assembled
018	2200.18	2210.18	043	2200.43	2210.43	088	2200.88	2210.88
023	2200.23	2210.23	048	2200.48	2210.48	099	2200.99	2210.99
028	2200.28	2210.28	058	2200.58	2210.58	124	2200.124	2210.124
033	2200.33	2210.33	068	2200.68	2210.68	149	2200.149	2210.149
038	2200.38	2210.38	073	2200.73	2210.73			



## Series R68 | Removable lids along outer radius

Removable lids along outer radius	<i>Bi</i> [mm]	<i>Ba</i> [mm]	<i>R</i> Bending radii [mm]										Weight [kg/m]
68.050.R.0	50	68	100	125	150	175	200	225	250	300	≈ 1,90		
68.075.R.0	75	93	100	125	150	175	200	225	250	300	≈ 2,18		
68.100.R.0	100	118	100	125	150	175	200	225	250	300	≈ 2,46		
68.115.R.0	115	133	100	125	150	175	200	225	250	300	≈ 2,63		
68.125.R.0	125	143	100	125	150	175	200	225	250	300	≈ 2,77		
68.150.R.0	150	168	100	125	150	175	200	225	250	300	≈ 3,05		
68.175.R.0	175	193	100	125	150	175	200	225	250	300	≈ 3,36		
68.200.R.0	200	218	100	125	150	175	200	225	250	300	≈ 3,64		
68.225.R.0	225	243	100	125	150	175	200	225	250	300	≈ 3,92		
68.250.R.0	250	268	100	125	150	175	200	225	250	300	≈ 4,23		

Supplement Part No. with required radius. Example: **68.100.100.0**

### Hot Chips up to 850°C

e-tubes that repel hot chips, up to 850 °C. Some applications, depending on amount and size of the chips, can burn or melt the surface. That is no longer the case with the igus® igumid HT™ material. Order example: Full e-tube made of igumid HT:

**Part No. 68.100.100.0.HT** (for long travels upon request)

Delivery time upon request. **Further Information** ► [www.igus.eu/HT](http://www.igus.eu/HT)

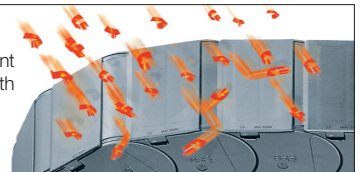



## Unsupported applications | Short travels

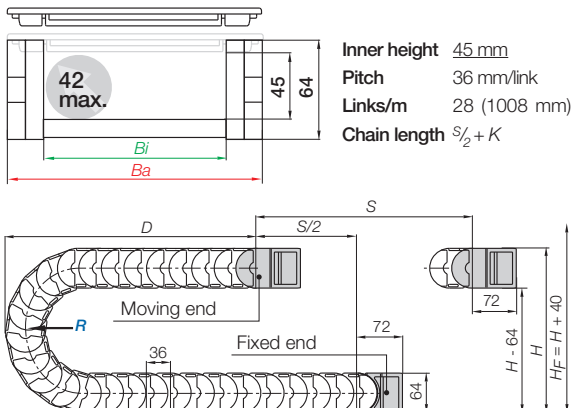
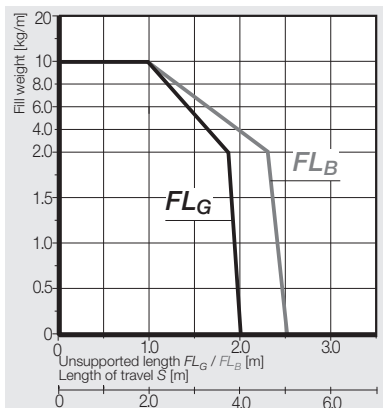

	R 100	125	150	175	200	225	250	300
H	264	314	364	414	464	514	564	664
D	186	211	236	261	286	311	336	386
K	390	465	545	625	705	780	860	1015

The required clearance height:  $H_F = H + 40$  mm (with 2,5 kg/m fill weight)

## Gliding<sup>1)</sup> applications | Long travels from 6 m to max. 100 m

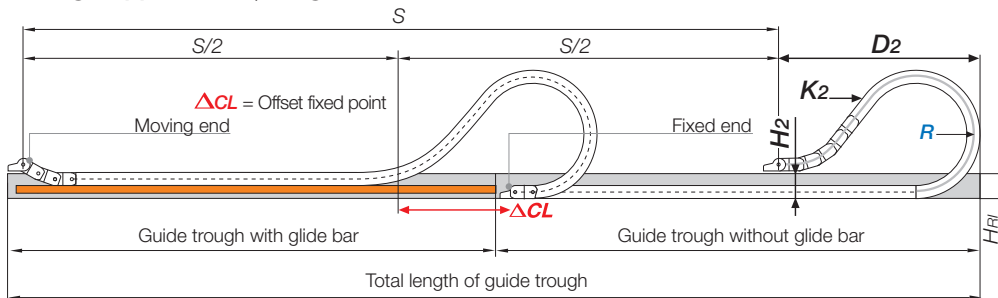

**Note:** For long travel applications with more than 100 m we recommend to realize the engineering of such a plant by our technicians. In case of travels between 4 and 6 m we recommend a longer unsupported length. **Chain length**  $\frac{S}{2} + K_2$

<sup>1)</sup> For gliding applications, please consult igus\*.

	R 100	125	150	175	200	225	250	300
$H_2$	265	284	284	284	284	284	284	284
$D_2$	200	370	440	540	650	700	850	1050
$K_2$	500	648	792	900	1116	1269	1476	1800
$\Delta CL$	*	164	204	294	364	439	514	664

\*Values upon request

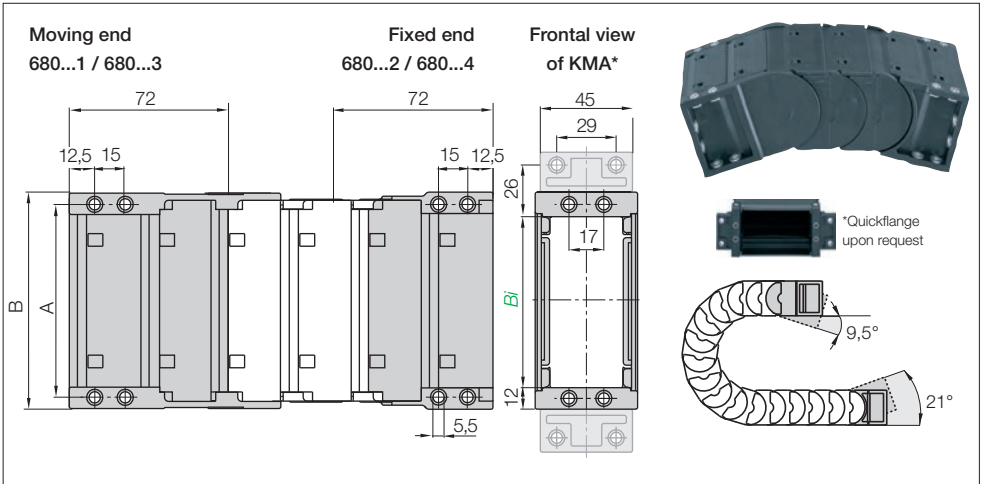

**KMA pivoting | Standard | Recommended for unsupported applications**

**KMA locking | Recommended for vertical hanging and standing applications**

Width Index	 Part No. full set <b>KMA pivoting:</b>	Part No. full set <b>KMA locking:</b>	Dim A [mm]	Dim B [mm]
.050. ▶	<b>680.050.12</b>	<b>680.050.34</b>	62	74
.075. ▶	<b>680.075.12</b>	<b>680.075.34</b>	87	99
.100. ▶	<b>680.100.12</b>	<b>680.100.34</b>	112	124
.115. ▶	<b>680.115.12</b>	<b>680.115.34</b>	127	139
.125. ▶	<b>680.125.12</b>	<b>680.125.34</b>	137	149
.150. ▶	<b>680.150.12</b>	<b>680.150.34</b>	162	174
.175. ▶	<b>680.175.12</b>	<b>680.175.34</b>	187	199
.200. ▶	<b>680.200.12</b>	<b>680.200.34</b>	212	224
.225. ▶	<b>680.225.12</b>	<b>680.225.34</b>	237	249
.250. ▶	<b>680.250.12</b>	<b>680.250.34</b>	262	274

Full set with assembled Quickflange, please add index **QF** ▶ e.g. **680.100.12.QF**. Quickflange unassembled: **Part No. 16800.QF**

(KMA = Polymer Metal Mounting Bracket)

The following parts are required for attachment of the mounting brackets:

- Socket head cap bolt M5 DIN 912-8.8 Length depends on the thickness of the attachment base
- Hexagon nut M5 DIN 934-8 ● Washer 5,3 DIN 125-ST

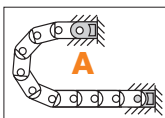

These attachment types are set automatically in the choice of the KMA mounting bracket.  
For the **preassembled** mode please add index **A**.

**Part No. structure**

**680. 100. 12 A**

A...must be indicated on preassembled configurations

**Full set pivoting = 12**

**Width index**

Mounting bracket for selected width index



**Strain relief** e.g. clamps, tiewrap plates, nuggets and plug-in clips are available from stock. The complete chainfix range with order options ▶ from page 630

## Mounting brackets, flange steel | pivoting

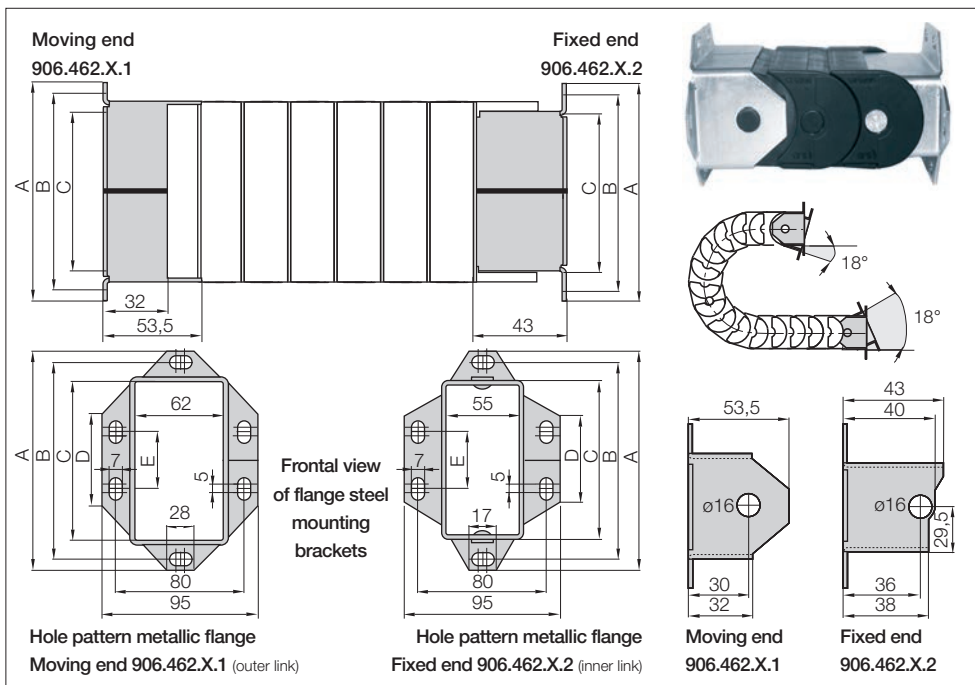

## Flange steel, pivoting | Recommended for unsupported applications

Width Index	Hole pattern	Part No. Moving end	Bi [mm]	Dim A [mm]	Dim B [mm]	Dim C [mm]	Dim D [mm]	Dim E [mm]
.075. ▶	68.1	906.462.1.1	75	116	104	83,3	50	30
.115. ▶	68.2	906.462.2.1	115	156	144	123,3	90	50
.115. ▶	68.3	906.462.3.1	175	216	204	183,3	150	100
Width Index	Hole pattern	Part No. Fixed end	Bi [mm]	Dim A [mm]	Dim B [mm]	Dim C [mm]	Dim D [mm]	Dim E [mm]
.075. ▶	68.1	906.462.1.2	75	116	104	83,4	38	30
.115. ▶	68.2	906.462.2.2	115	156	144	123,4	78	50
.115. ▶	68.3	906.462.3.2	175	216	204	183,4	138	100

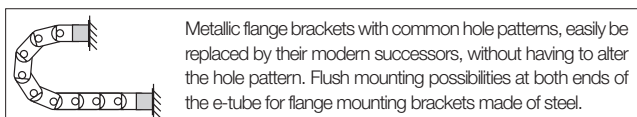

 **Strain relief** e.g. clamps, tiwrap plates, nuggets and plug-in clips are available from stock. The complete chainfix range with order options ▶ from page 630

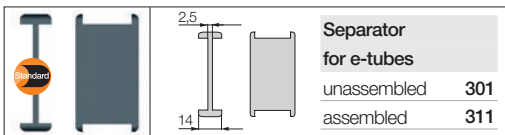
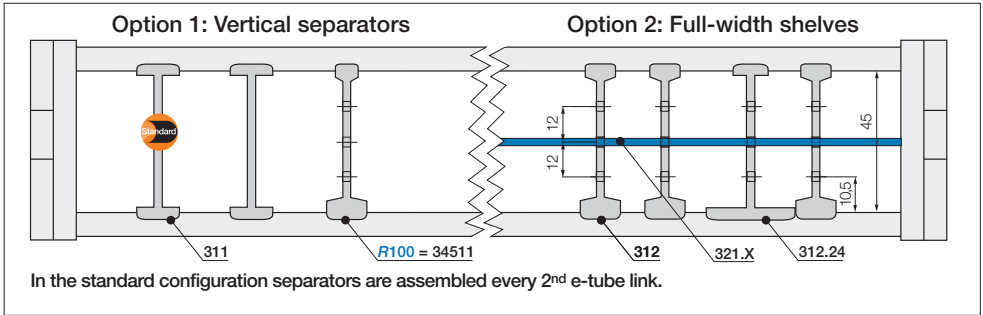

### Separator 301

For a vertical subdivision.

Offers safe stability due to its wide base design, also when used with thick cables or hoses.

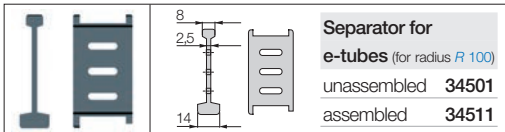

### Separator 34511

if you select bending radius  $R 100$  please use this Separator for a vertical subdivision.

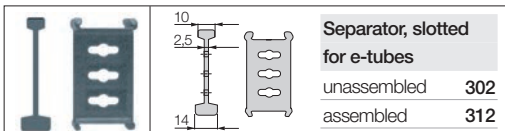

### Slotted separator 302

is used when vertical and horizontal separation is required. Due to its slot, it allows basic vertical/horizontal shelving arrangements.

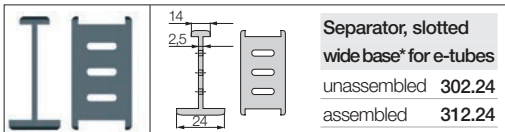

### Slotted separator 302.24

If a wide space between the separators has to be kept or separators have to be fixed in their position.

(\*for side-mounted applications)

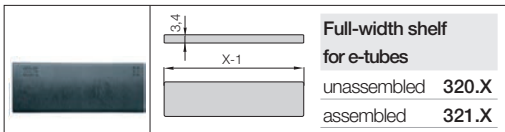

### Full-width shelf 320.X

This option makes sense in applications with many thin cables with similar diameters. Full-width shelves can be arranged at 3 different heights (in 12 mm increments).

### Full-width shelf

Width X [mm]	unassembled	assembled	Width X [mm]	unassembled	assembled	Width X [mm]	unassembled	assembled
050	320.050	321.050	125	320.125	321.125	225	320.225	321.225
075	320.075	321.075	150	320.150	321.150	250	320.250	321.250
100	320.100	321.100	175	320.175	321.175			
115	320.115	321.115	200	320.200	321.200			

## Interior separation | Option 3

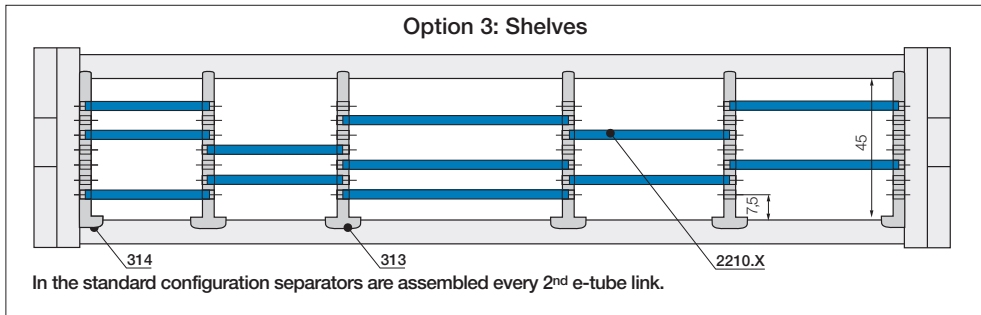

**Side plate for e-tubes**

unassembled	<b>303</b>
assembled	<b>313</b>

### Side plate 303

Side plate for use with shelf 2200.X and middle plate 304.

**Middle plate for e-tubes**

unassembled	<b>304</b>
assembled	<b>314</b>

### Middle plate 304

To achieve a modular shelving the shelf 2200.X can be arranged at 7 different heights (in 5 mm increments).

**Shelf for e-tubes**

unassembled	<b>2200.X</b>
assembled	<b>2210.X</b>

### Shelf 2200.X

For applications involving many cables with different diameters, shelves can be arranged at alternate heights. They can be arranged at 5 different heights (in 5 mm increments).

## Shelves

Width X [mm]	unassembled	assembled	Width X [mm]	unassembled	assembled	Width X [mm]	unassembled	assembled
018	2200.18	2210.18	043	2200.43	2210.43	088	2200.88	2210.88
023	2200.23	2210.23	048	2200.48	2210.48	099	2200.99	2210.99
028	2200.28	2210.28	058	2200.58	2210.58	124	2200.124	2210.124
033	2200.33	2210.33	068	2200.68	2210.68	149	2200.149	2210.149
038	2200.38	2210.38	073	2200.73	2210.73			

# RX System - Extremely chip repellent e-tubes

## Problem solver for energy supply systems in areas with chips - available in 4 sizes

Chips and dirt can significantly reduce the service life of cables and hoses. With RX System igus® presents an extremely tough but smoothly shaped polymer e-tube that can easily be opened along the outer radius.

- Round contour prevents chip accumulation
- Injection-molded "sealing lip" all around
- No holes, cracks or undercuts
- IP40 tested (TÜV Saarland) - RX40
- Interior separation and support tray tool kit available
- Covered pin/bore connection and stop dogs
- "RBR"-Version with reverse bending radius available

## Typical industries and applications

- Tooling machines
- All applications with direct chip appearance
- Applications with dirt and dust
- General machinery



RX e-tubes -  
IP tested



Special equipment: Electrically conductive  
ESD/ATEX version upon request



UL94-V0 classifications  
upon request



Optional available with igumid  
HT-Material for hot chips up to 850 °C



reddot design award  
winner 2011

Flush attachment:  
Mounting bracket with  
strain relief option

Smooth:  
Without undercuts,  
projecting edges or gaps

Dirt repellent:  
Round contour prevents  
chip accumulation

Keep order:  
Interior separation  
available

Quick assembly:  
Removable lids along outer  
radius with embedded  
locking mechanism

Safe:  
Covered pin/bore  
connection and stop dogs





# RX e-tubes | Selection Table

Series	Inner height <i>hi</i> [mm]	Inner width <i>Bi</i> [mm]	Outer width <i>Ba</i> [mm]	Outer height <i>ha</i> [mm]	Bending radius <i>R</i> [mm]	Unsupported max. length [m]	Page
--------	--------------------------------	-------------------------------	-------------------------------	--------------------------------	---------------------------------	--------------------------------	------



**RX System -**  
Extremely chip repellent e-tubes  
Removable lids along outer radius

<b>RX32</b>	26 / 42	80	98,4	56	80 - 150	1,7	<b>346</b>
<b>RX40</b>	32 / 52	100	123	70	100 - 300	1,8	<b>350</b>
<b>RX48</b>	35 / 62	120	147,6	84	120 - 150	2,1	<b>354</b>
<b>RX56</b>	41 / 73	140	172,2	98	140	2,3	<b>358</b>

**RX32**

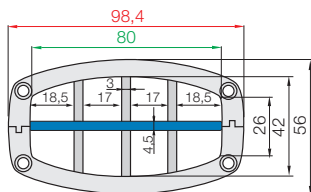

**RX40**

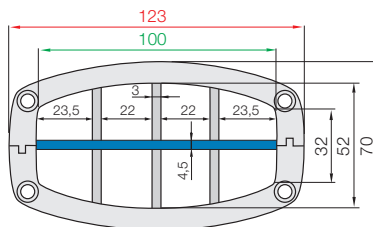

**RX48**

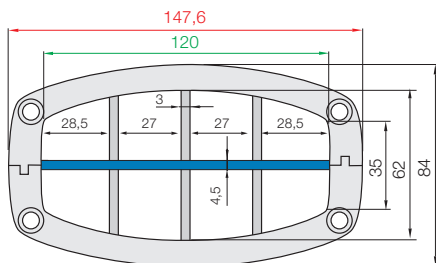

**RX56**

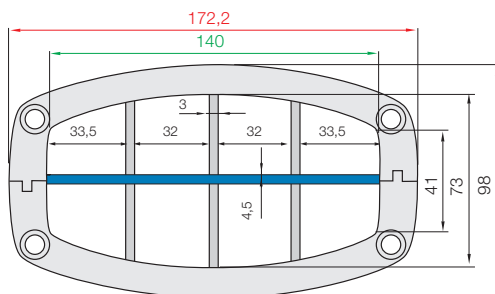

## Technical Data



Speed / acceleration  $FL_G$  max.

max. 10 [m/s] / max. 100 [m/s<sup>2</sup>]



Speed / acceleration  $FL_B$  max.

max. 3 [m/s] / max. 6 [m/s<sup>2</sup>]



Material - permitted temperature °C, igumid G / GLW

40° up to +100° C



Flammability class, igumid G / GLW

VDE 0304 IIC UL94-HB

■  $FL_G$  = with straight upper run ■  $FL_B$  = with permitted sag

## Installation methods overview, maximum travels

e-tube Series	Unsupported application	Vertical hanging	Vertical standing	Side mounted unsupported	Rotary application	Zig-zag application
RX32	≤ 1,20 m	upon request	upon request	upon request	—	upon request
RX40	≤ 1,50 m	upon request	upon request	upon request	—	upon request
RX48	≤ 1,80 m	upon request	upon request	upon request	—	upon request
RX56	≤ 2,00 m	upon request	upon request	upon request	—	upon request

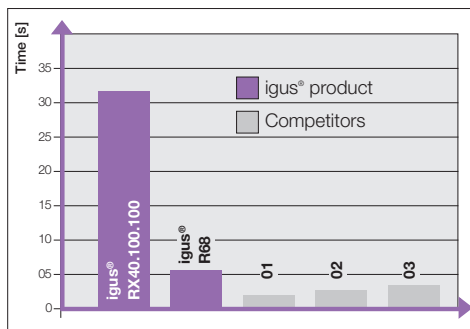



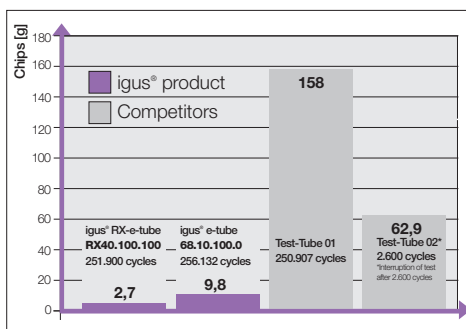





Test: Drowning - Various tube styles were drowned under water. For the RX e-tube, it takes more than 30 sec. to fill up with water



Test: Chip intrusion - Various tube styles were charged with a defined quantity of chips. Only 2,7 g of chips were found inside the RX e-tube after 251.900 cycles

# RX e-tubes | Order keys and Options

## Options with order keys based on Series RX40

 <b>Standard</b>  Part No. <b>Standard</b> RX e-tubes 	Reverse bending radius for circular movements  Part No. <b>RBR</b> RX e-tubes 	No burning-in of hot chips up to 850°C (1562° F)  Part No. <b>igumid HT-Material</b> RX e-tubes 	ATEX / ESD classified e-chains® -  II 2 GD  Part No. <b>ESD-Material</b> RX e-tubes 
 <b>RX40.100.R.0</b>	<b>RX40.100.R1/R2.0</b>	<b>RX40.100.R.0.HT</b>	<b>RX40.100.R.0.ESD</b>
 <b>Delivery from stock</b>	<b>Delivery time: upon request</b>	<b>Delivery time: upon request</b>	<b>Delivery time: upon request</b>

## Order example | Order key and color options based on Series RX40

 **Order example for complete e-tube (1,0 m), color black, with mounting brackets and interior separation:**

e-tube (1,0 m)	Please indicate e-tube length or number of links: 1,0 m or 25 links	<b>RX40.100.100.0</b>
+ Mounting brackets	1 set (+ tiwrap plates)	<b>RX401.100.12ZB</b>
+ Interior separation	with 1 separator (central positioning) assembled every 2 <sup>nd</sup> link	<b>1 x RX40.1.1</b>
+ Interior separation	with 2 separators (lateral positioning) assembled every 2 <sup>nd</sup> link	<b>2 x RX40.2.1</b>

Order text: 1,0 m RX40.100.100.0 + RX401.100.12 ZB + 1 x RX40.1.1 + 2 x RX40.2.1

### Order key

e-tube - removable lids along outer radius **RX40.100.100.0**



Series / Type

Width index (depends on *B*)

Bending radius *R*

Color index (standard black)

**RX40.100.100.0** = e-tube snap-open along outer radius,  
*B* 100 mm inner width, *R* 100 mm radius, color black

### General igus® color options for e-chains® and e-tubes

Color	Order index	Color	Order index
<b>Black</b> Standard, from stock!	<b>.0</b>	<b>White</b> special color	<b>.1</b>
<b>Slate grey</b> only ESD material	<b>.ESD</b>	<b>Gray white</b> special color	<b>.1S</b>
<b>Gray brown</b> only HT material	<b>.HT</b>	<b>Orange</b> special color	<b>.2</b>
<b>Gray</b> special color only e-chains®	<b>.3</b>	<b>Yellow</b> special color	<b>.4</b>
<b>Dusty grey</b> special color only e-tubes	<b>.31</b>	<b>Light grey</b> special color	<b>.14</b>

**Black e-chains® available from stock!**

**Delivery time for special colors: upon request**



## Series RX32 | Removable lids along outer radius

Removable lids along outer radius	<i>Bi</i> [mm]	<i>Ba</i> [mm]	<i>R</i> Bending radii [mm]								Weight [kg/m]
<b>RX32.080.R.0</b>	<b>80</b>	<b>98,4</b>	<b>080</b>	<b>100*</b>	<b>125*</b>	<b>150</b>	<b>175*</b>	<b>200*</b>	<b>225*</b>	<b>250*</b>	≈ 1,23

\*Radius available upon request, please consult igus\* for delivery time!

Supplement Part No. with required radius (*R*). Example: **RX32.080.080.0**

## Dimensions

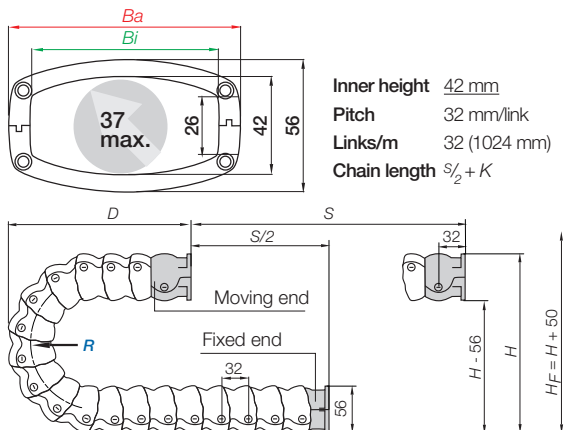
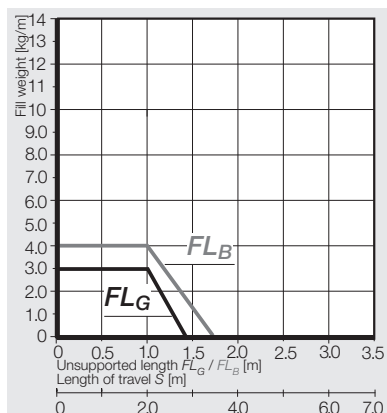

<i>R</i>	080	100*	125*	150	175*	200*	225*	250*
<i>H</i>	216	256	306	356	406	456	506	556
<i>D</i>	156	176	201	226	251	276	301	326
<i>K</i>	320	380	460	540	615	695	775	850

The required clearance height:  $H_F = H + 50$  mm (with 0,5 kg/m fill weight)

\*Radius available upon request, please consult igus\* for delivery time!

Mounting brackets, flange | Polymer locking, two-piece

**Moving end**  
RX321.080.1(ZB)

**Fixed end**  
RX321.080.2(ZB)

**Frontal view of flange**

**Lateral view of igus® RX32 e-tube with flange mounting brackets and optional strain relief (upon request)**

Two-piece mounting bracket with flange attachment

Flange mounting brackets, locking

Width Index	Part No. full set <b>with</b> tiewrap plates	Part No. full set <b>without</b> tiewrap plates	Number of teeth
.080. ▶	RX321.080.12ZB	RX321.080.12	8

Flange mounting brackets for flush mounting possibilities. Easy fixation. Optional M6 insert nuts. For the **preassembled** mode please add index **A**.

**RX321.080.12ZB A** Part No. structure

- A... must be indicated on preassembled configurations
- With integrated strain relief tiewrap plates
- Full set**
- Width Index
- Mounting bracket for selected width index

**Strain relief** e.g. clamps, tiewrap plates, nuggets and plug-in clips are available from stock. The complete chainfix range with order options ▶ from page 630

Interior separation

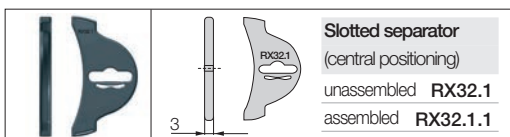
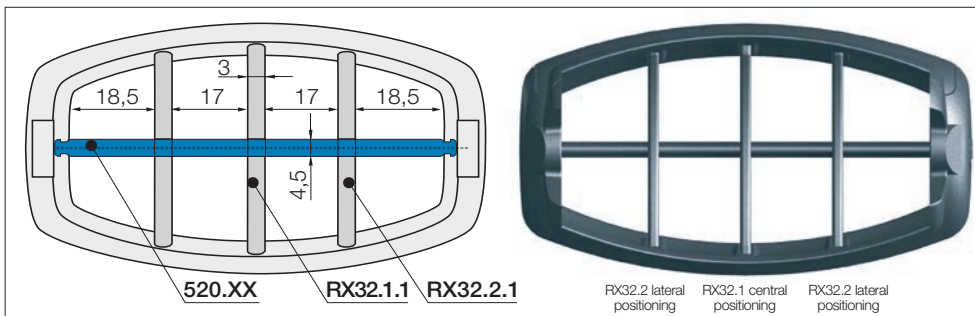

**Slotted separator**  
(central positioning)  
unassembled **RX32.1**  
assembled **RX32.1.1**

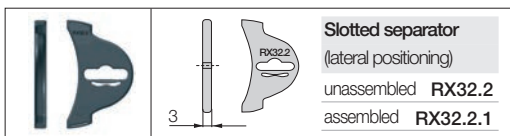

**Slotted separator**  
(lateral positioning)  
unassembled **RX32.2**  
assembled **RX32.2.1**

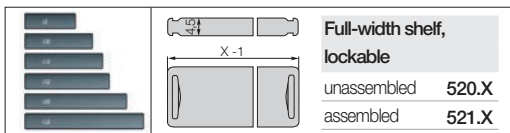

**Full-width shelf, lockable**  
unassembled **520.X**  
assembled **521.X**

**Vertical separation - slotted separators:**

**RX32.1** (central positioning)

**RX32.2** (lateral positioning)

Vertical separation of the large filling space by cable-friendly, polymer separators. Due to their slots, basic vertical/horizontal shelving arrangements are possible. In the standard configuration separators are assembled every 2<sup>nd</sup> e-chain® link!

**Horizontal separation**

Full-width shelf locks safely into separators on both ends, fixed width possible. Separators can be moved freely over the shelf in horizontal direction. Can be used at one height.

**Lockable full-width shelves**

Width X [mm]	unassembled	assembled	Width X [mm]	unassembled	assembled
029	520.29	521.29	079	520.79	521.79
054	520.54	521.54	104	520.104	521.104



## Hot Chips up to 850°C

RX e-tubes that repel hot chips, up to 850 °C. Some applications, depending on amount and size of the chips, can burn or melt the surface. That is no longer the case with the igus® "igumid HT" material. Order example: **Part No. RX32.080.080.0.HT** Delivery time upon request.

Further Information ► [www.igus.eu/eu/HT](http://www.igus.eu/eu/HT)



## Optional: Support tray tool kit.

For support of the lower run.

- Open trough design for safe guidance of the RX e-tube
- Chips can fall through ● In 2 lengths available

Further Information ► [www.igus.eu/eu/RX32](http://www.igus.eu/eu/RX32)



## Polymer strain relief block.

For RX e-tubes flange mounting brackets.

- Tight strain relief block according to your specifications ● Fast assembly by standard screw connection ● Can be mounted in the mounting bracket

Further Information ► [www.igus.eu/eu/RX32](http://www.igus.eu/eu/RX32)

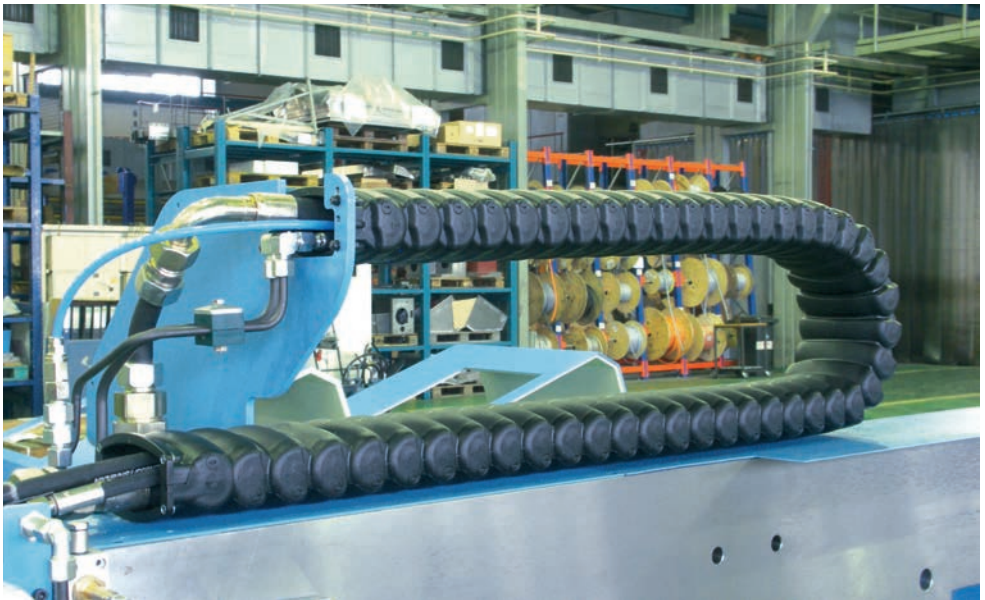

Supply of the main spindle in a tooling machine with igus® RX e-tube. The rounded contour of the energy supply repels all kind of chips



## Series RX40 | Removable lids along outer radius

Removable lids along outer radius	<i>Bi</i> [mm]	<i>Ba</i> [mm]	<i>R</i> Bending radii [mm]										Weight [kg/m]
RX40.100.R.0	100	123	100	125	150	175	200	225	250	275	300	~ 1,89	

Supplement Part No. with required radius (*R*). Example: RX40.080.080.0

## Dimensions

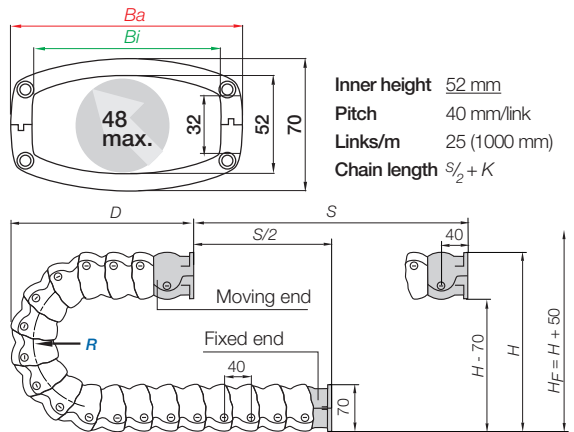
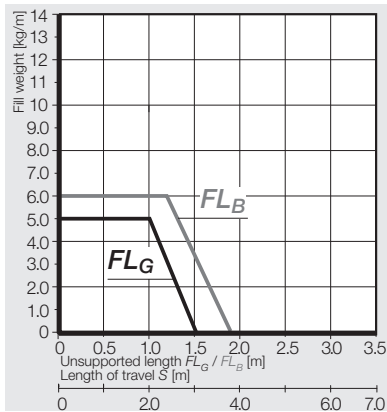

<i>R</i>	100	125	150	175	200	225	250	275	300
<i>H</i>	270	320	370	420	470	520	570	620	670
<i>D</i>	195	220	245	270	295	320	345	370	395
<i>K</i>	395	475	555	630	710	790	870	945	1025

The required clearance height:  $H_F = H + 50$  mm (with 0,5 kg/m fill weight)



Mounting brackets, flange | Polymer locking, two-piece

Moving end  
RX401.100.1(ZB)

Fixed end  
RX401.100.2(ZB)

Frontal view  
of flange

Lateral view of igus®  
RX40 e-tube with flange  
mounting brackets  
and optional strain relief  
(upon request)

Two-piece mounting bracket  
with flange attachment

Flange mounting brackets, locking

Width Index	Part No. full set <b>with</b> tiewrap plates	Part No. full set <b>without</b> tiewrap plates	Number of teeth
.100. ▶	RX401.100.12ZB	RX401.100.12	10

Flange mounting brackets for flush mounting possibilities. Easy fixation. Optional M6 insert nuts. For the **preassembled** mode please add index **A**.

**RX401.100.12ZB A** Part No. structure

- A... must be indicated on preassembled configurations
- With integrated strain relief tiewrap plates
- Full set**
- Width Index
- Mounting bracket for selected width index

**Strain relief** e.g. clamps, tiewrap plates, nuggets and plug-in clips are available from stock. The complete chainfix range with order options ▶ from page 630

## Interior separation

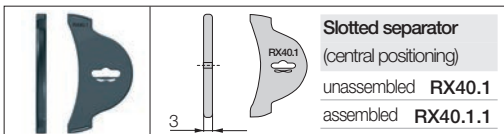
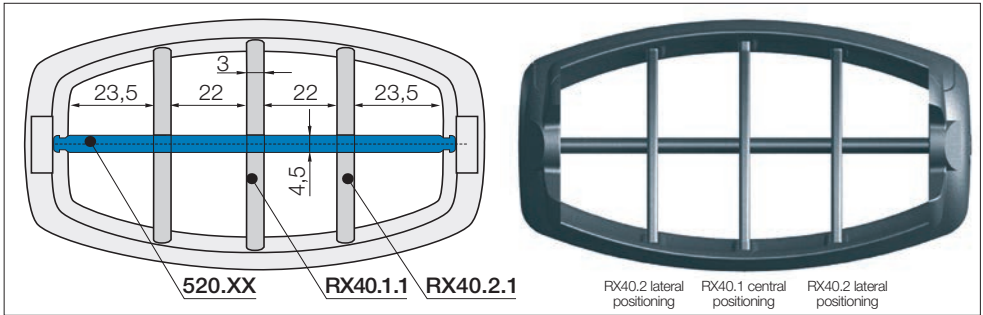
**Slotted separator**  
(central positioning)

unassembled **RX40.1**  
assembled **RX40.1.1**

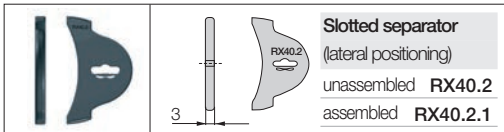
**Slotted separator**  
(lateral positioning)

unassembled **RX40.2**  
assembled **RX40.2.1**

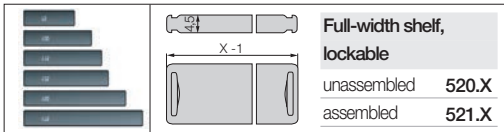
**Full-width shelf,**  
**lockable**

unassembled **520.X**  
assembled **521.X**

**Vertical separation - slotted separators:****RX40.1** (central positioning)**RX40.2** (lateral positioning)

Vertical separation of the large filling space by cable-friendly, polymer separators. Due to their slots, basic vertical/horizontal shelving arrangements are possible. In the standard configuration separators are assembled every 2<sup>nd</sup> e-chain® link!

**Horizontal separation**

Full-width shelf locks safely into separators on both ends, fixed width possible. Separators can be moved freely over the shelf in horizontal direction. Can be used at one height.

**Lockable full-width shelves**

Width X [mm]	unassembled	assembled	Width X [mm]	unassembled	assembled
029	520.29	521.29	079	520.79	521.79
054	520.54	521.54	104	520.104	521.104



**Hot Chips up to 850°C**

RX e-tubes that repel hot chips, up to 850 °C. Some applications, depending on amount and size of the chips, can burn or melt the surface. That is no longer the case with the igus® "igumid HT" material. Order example: **Part No. RX40.100.100.0.HT** Delivery time upon request.

Further Information ► [www.igus.eu/eu/HT](http://www.igus.eu/eu/HT)



**Optional: Support tray tool kit.**

For support of the lower run.

- Open trough design for safe guidance of the RX e-tube
- Chips can fall through ● In 2 lengths available

Further Information ► [www.igus.eu/eu/RX40](http://www.igus.eu/eu/RX40)



**Polymer strain relief block.**

For RX e-tubes flange mounting brackets.

- Tight strain relief block according to your specifications ● Fast assembly by standard screw connection ● Can be mounted in the mounting bracket

Further Information ► [www.igus.eu/eu/RX40](http://www.igus.eu/eu/RX40)



Chip tests at the igus® test-lab prove the excellent tightness of RX e-tube. Video online ► [www.igus.eu/eu/RX\\_tested](http://www.igus.eu/eu/RX_tested)



## Series RX48 | Removable lids along outer radius

Removable lids along outer radius	<i>Bi</i> [mm]	<i>Ba</i> [mm]	<i>R</i> Bending radii [mm]								Weight [kg/m]	
RX48. 120 .R.0	120	147,6	120	150	175*	200*	225*	250*	275*	300*	325*	~2,76

\*Radius available upon request, please consult igus\* for delivery time!

Supplement Part No. with required radius (*R*). Example: RX48.120.120.0

## Dimensions

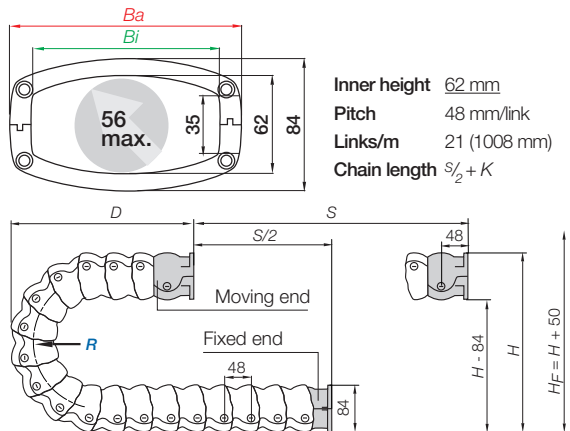
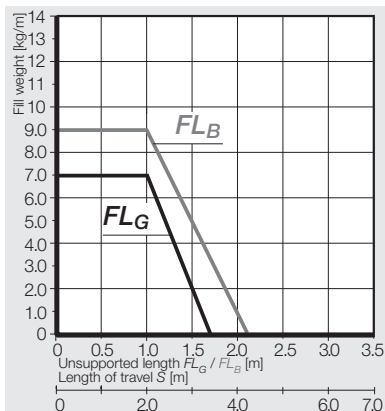

<i>R</i>	120	150	175*	200*	225*	250*	275*	300*	325*
<i>H</i>	324	384	434	484	534	584	634	684	734
<i>D</i>	234	264	289	314	339	364	389	414	439
<i>K</i>	475	570	650	725	805	885	960	1040	1120

The required clearance height:  $H_F = H + 50$  mm (with 0,5 kg/m fill weight)

\*Radius available upon request, please consult igus\* for delivery time!

Mounting brackets, flange | Polymer locking, two-piece

Moving end  
RX481.120.1

Fixed end  
RX481.120.2

Frontal view  
of flange

Lateral view of igus®  
RX48 e-tube with flange  
mounting brackets  
and optional strain relief  
(upon request)

Two-piece mounting bracket  
with flange attachment

Flange mounting brackets, locking

Width Index	Part No. full set with tiewrap plates	Part No. full set without tiewrap plates	Number of teeth
.120. ▶	upon request	RX481.120.12	upon request

**A**

Flange mounting brackets for flush mounting possibilities. Easy fixation. Optional M6 insert nuts. For the **preassembled** mode please add index **A**.

RX481.120.12 **A** Part No. structure



**Strain relief** e.g. clamps, tiewrap plates, nuggets and plug-in clips are available from stock. The complete chainfix range with order options ▶ from page 630

## Interior separation

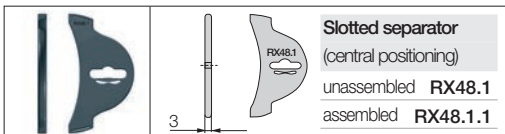
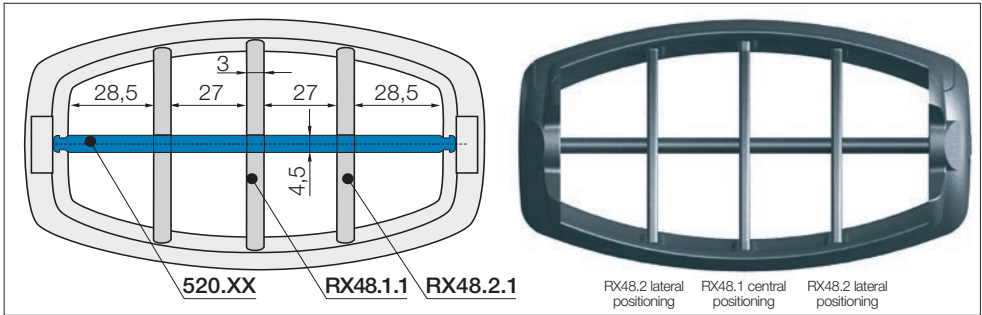

## Vertical separation - slotted separators:

RX48.1 (central positioning)

RX48.2 (lateral positioning)

Vertical separation of the large filling space by cable-friendly, polymer separators. Due to their slots, basic vertical/horizontal shelving arrangements are possible. In the standard configuration separators are assembled every 2<sup>nd</sup> e-chain® link!

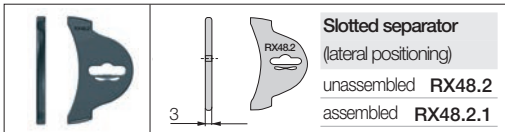

## Horizontal separation

Full-width shelf locks safely into separators on both ends, fixed width possible. Separators can be moved freely over the shelf in horizontal direction. Can be used at one height.

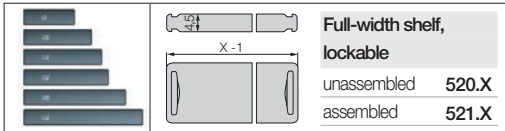

## Lockable full-width shelves

Width X [mm]	unassembled	assembled	Width X [mm]	unassembled	assembled
034	520.34	521.34	094	520.94	521.94
064	520.64	521.64	124	520.124	521.124



**Hot Chips up to 850°C**

RX e-tubes that repel hot chips, up to 850 °C. Some applications, depending on amount and size of the chips, can burn or melt the surface. That is no longer the case with the igus® "igumid HT" material. Order example: **Part No. RX48.120.120.0.HT** Delivery time upon request.

Further Information ► [www.igus.eu/eu/HT](http://www.igus.eu/eu/HT)



**Optional: Support tray tool kit.**

For support of the lower run.

- Open trough design for safe guidance of the RX e-tube
- Chips can fall through ● In 2 lengths available

Further Information ► [www.igus.eu/eu/RX48](http://www.igus.eu/eu/RX48)



**Polymer strain relief block.**

For RX e-tubes flange mounting brackets.

- Tight strain relief block according to your specifications ● Fast assembly by standard screw connection ● Can be mounted in the mounting bracket

Further Information ► [www.igus.eu/eu/RX48](http://www.igus.eu/eu/RX48)



With the extreme tight igus® RX e-tube and the harnessed chainflex®-cables, the lifetime of this woodworking machine could be considerably increased. Because of dust and dirt, most after one month previously installed cables failed



## Series RX56 | Removable lids along outer radius

Removable lids along outer radius	<i>Bi</i> [mm]	<i>Ba</i> [mm]	<i>R</i> Bending radii [mm]	Weight [kg/m]
RX56. 140 .R.0	140	172,2	140   175*   200*   225*   250*   275*   300*   325*   350*	~3,83

\*Radius available upon request, please consult igus\* for delivery time!

Supplement Part No. with required radius (*R*). Example: RX56.140.140.0

## Dimensions

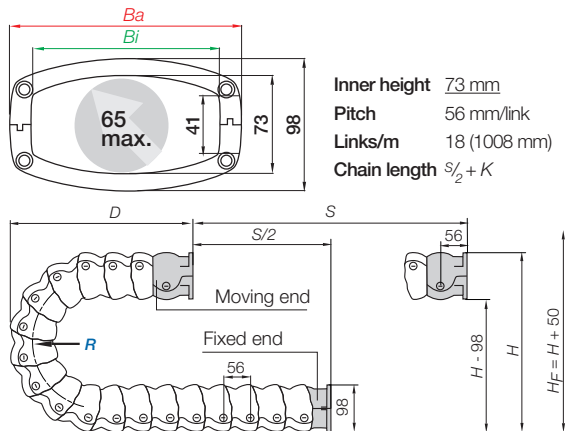
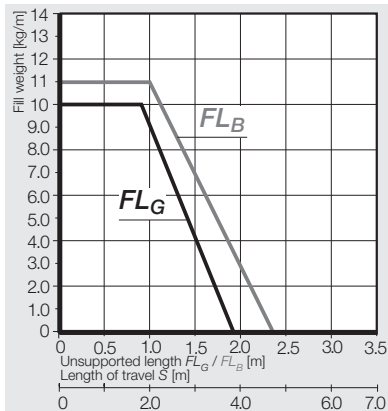

<i>R</i>	140	175*	200*	225*	250*	275*	300*	325*	350*
<i>H</i>	378	448	498	548	598	648	698	748	798
<i>D</i>	273	308	333	358	383	408	433	458	483
<i>K</i>	555	665	745	820	900	980	1055	1135	1215

The required clearance height:  $H_F = H + 50$  mm (with 0,5 kg/m fill weight)

\*Radius available upon request, please consult igus\* for delivery time!



Mounting brackets, flange | Polymer locking, two-piece

Moving end  
RX561.140.1

Fixed end  
RX561.140.2

Frontal view  
of flange

Lateral view of igus®  
RX56 e-tube with flange  
mounting brackets  
and optional strain relief  
(upon request)

Two-piece mounting bracket  
with flange attachment

Flange mounting brackets, locking

Width Index	Part No. full set with tiewrap plates	Part No. full set without tiewrap plates	Number of teeth
.140. ▶	upon request	RX561.120.12	upon request

Flange mounting brackets for flush mounting possibilities. Easy fixation. Optional M6 insert nuts. For the **preassembled** mode please add index **A**.

RX561.120.12 A Part No. structure



 **Strain relief** e.g. clamps, tiewrap plates, nuggets and plug-in clips are available from stock. The complete chainfix range with order options ▶ from page 630

Interior separation

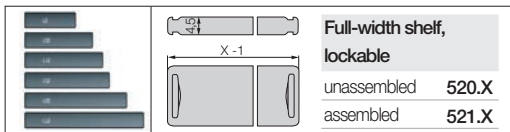
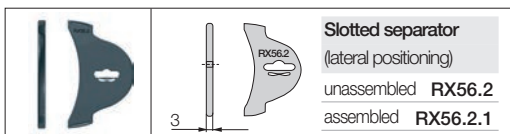
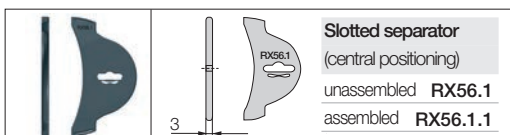
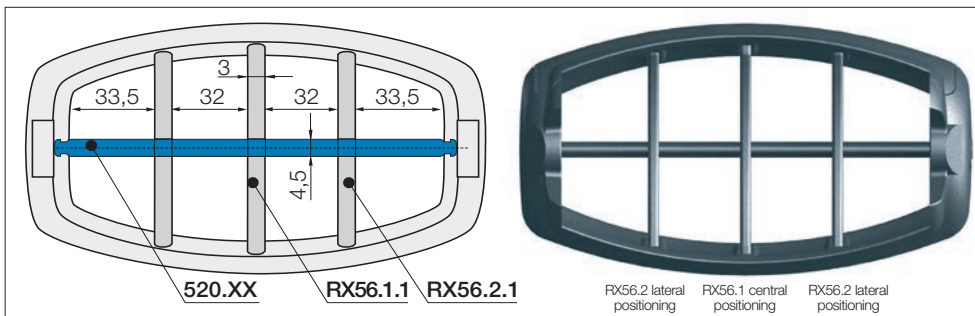

Vertical separation - slotted separators:

RX56.1 (central positioning)

RX56.2 (lateral positioning)

Vertical separation of the large filling space by cable-friendly, polymer separators. Due to their slots, basic vertical/horizontal shelving arrangements are possible. In the standard configuration separators are assembled every 2<sup>nd</sup> e-chain® link!

Horizontal separation

Full-width shelf locks safely into separators on both ends, fixed width possible. Separators can be moved freely over the shelf in horizontal direction. Can be used at one height.

Lockable full-width shelves

Width X [mm]	unassembled	assembled	Width X [mm]	unassembled	assembled
039	520.39	521.39	109	520.109	521.109
074	520.74	521.74	144	520.144	521.144



**Hot Chips up to 850°C**

RX e-tubes that repel hot chips, up to 850 °C. Some applications, depending on amount and size of the chips, can burn or melt the surface. That is no longer the case with the igus® "igumid HT" material. Order example: **Part No. RX56.140.140.0.HT** Delivery time upon request.

Further Information ► [www.igus.eu/eu/HT](http://www.igus.eu/eu/HT)



**Optional: Support tray tool kit.**

For support of the lower run.

- Open trough design for safe guidance of the RX e-tube
- Chips can fall through ● In 2 lengths available

Further Information ► [www.igus.eu/eu/RX56](http://www.igus.eu/eu/RX56)



**Polymer strain relief block.**

For RX e-tubes flange mounting brackets.

- Tight strain relief block according to your specifications ● Fast assembly by standard screw connection ● Can be mounted in the mounting bracket

Further Information ► [www.igus.eu/eu/RX56](http://www.igus.eu/eu/RX56)



Despite the restricted installation space, the RX e-tube is used in this compact turning machine with reverse bending radius (RBR)

## ONE e-chain® series for almost all applications

The E4.1 system combines all the advantages of its three predecessors. E4.1 profits from 25 years of igus® experience in 4-piece e-chains® and is the best igus® e-chain® in the product range. The E4.1 series is more stable with the same or smaller dimensions than their predecessors. Almost all accessory components and mounting dimensions are identical. With the E4.1, the service life of your application can be still increased with lower costs.

- Undercut design for best lateral stability, high shear force on long travels and for large unsupported lengths
- Well suited for side-mounted applications
- Noise dampening pads
- Outer and inner links for quick assembly, with or without pretension
- Dirt repellant, with smooth, wear-resistant surface and side wear pads

### Typical industries and applications

- Crane ● Indoor crane ● Composting plants
- Sewage plants ● Machine tools ● General mechanical engineering ● Materials handling technology ● Refrigeration engineering ● Construction machinery ● Wood working ● Any type of machines ● Robotics

Universal: Attachment on all sides

Low noise: Optional dampening pads

Chip protection: Openable lids

Long lifetime: Gliding surfaces for long travels

High stability: "Undercut" design, high strengths and loads

25% faster: Easy assembly with QuickLock-crossbars

Straight run: Due to inner/outer link principle

No camber: No rework due to special design principle

Precise dividing: Notch crossbar with visual scale

Low noise operation: Due to integrated "brakes"



Clean room test upon request



41 dB(A) tested at igus® lab, v = 1,8 m/s unsupported, Series E4.21.060.038.0



Electrically conductive ESD/ATEX versions several Series available from stock



e-tubes available as special design with HT material for 850°C hot chips



# E4.1 | Features | Accessories



New generation interior separation - even more cable-friendly



Previous interior separation - still available ► [www.igus.eu/eu/E4.1](http://www.igus.eu/eu/E4.1)

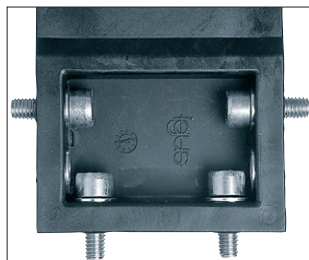

KMA mounting brackets with attachment options on all sides

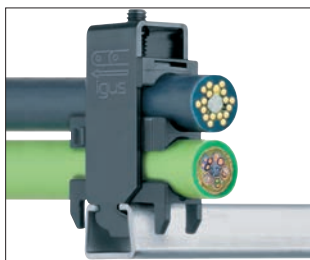

Strain relief e.g. clamps, tiwrap plates, nugs and plug-in clips ► **from page 630**

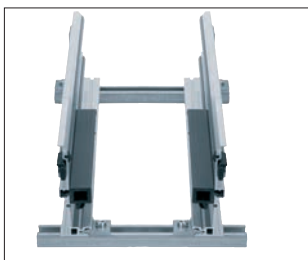

Guide troughs - "Super Aluminum Trough" Basic and Heavy-Duty ► **from page 664**

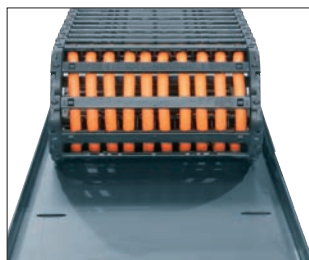

Support tray tool kit. For support of the lower run ► **from page 714**

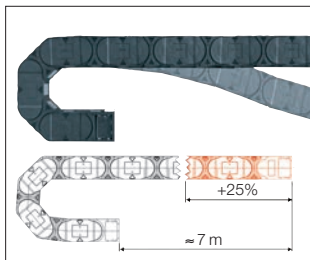

Up to 25% more unsupported length with XXL material ► [www.igus.eu/eu/E4.1](http://www.igus.eu/eu/E4.1)

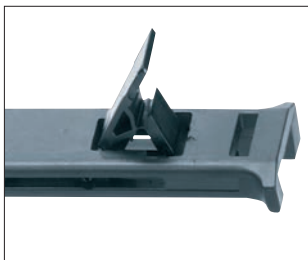

QuickLock crossbar - reduce assembly time up to 25% ► [www.igus.eu/eu/E4.1](http://www.igus.eu/eu/E4.1)



autoglide crossbars available, long travels without guide troughs

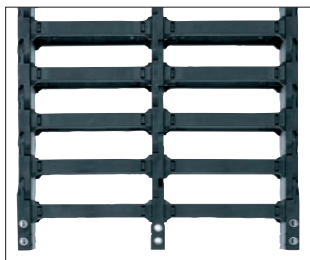

The extension link design allows virtually limitless side-by-side attachment



Round or square extender crossbar - safe guiding for large hoses



The E4 e-chain® opener reduces assembly time ► [www.igus.eu/eu/E4savetime](http://www.igus.eu/eu/E4savetime)

## E4.1 | All applications with one e-chain®

Undercut design principle combined with the inner/ outer-link solution

Smooth,  
cable-friendly  
inner surfaces

Low noise operation  
through integrated "brake"  
on the radial stop dogs

Smooth and wear-resis-  
tant gliding surface - no  
additional gliding shoe

Types with or without  
pretension by reversing  
outer links

Special e-chain® link contour  
provides low rolling noise

Optional noise  
dampening pads

Straight run and fast assembly  
due to inner- / outer-link design

## E4.1 | All applications with one e-chain®

Undercut design principle combined with the inner/ outer-link solution

Perfect ESD suitability due "tongue and groove" design

Stable crossbars with double locking

Double vertical stop dog system for larger unsupported lengths

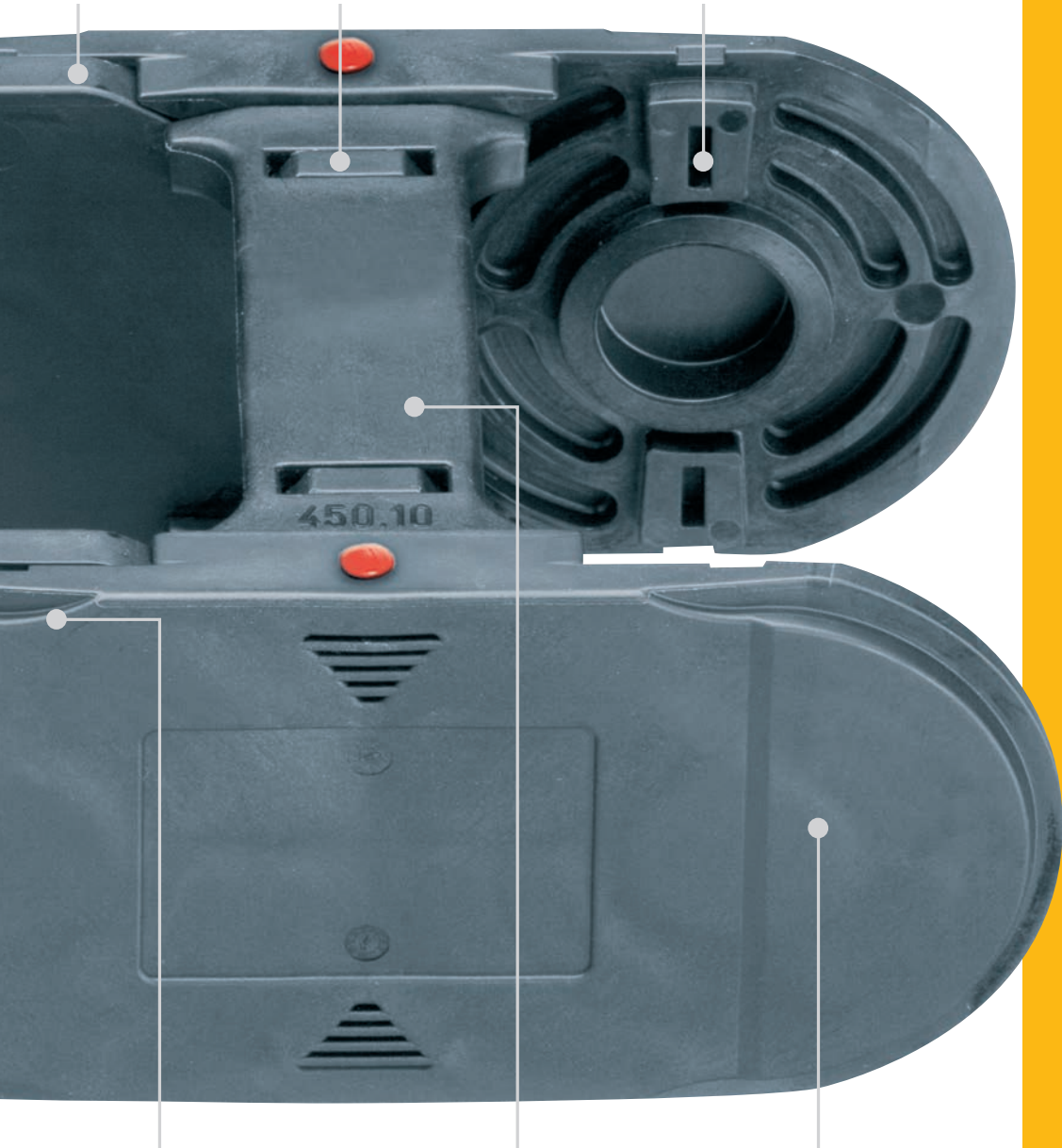

Very high stiffness and carrying capacity due to the undercut design

Cable-friendly, rounded crossbar

Integrated lateral wear pads for a long service life (also for side-mounted applications)

# E4.1 | Selection Table

Series	Inner height <i>hi</i> [mm]	Inner width <i>Bi</i> [mm]	Outer width <i>Ba</i> [mm]	Outer height <i>ha</i> [mm]	Bending radius <i>R</i> [mm]	Unsupported max. length. [m]	page
--------	--------------------------------	-------------------------------	-------------------------------	--------------------------------	---------------------------------	---------------------------------	------



## Crossbars every link

e-chains® for particularly demanding applications

E4.21	21	30 - 140	44 - 154	28	38 - 200	2,50	370
E4.28	28	40 - 300	60 - 320	42	55 - 250	2,50	374
E4.32	32	50 - 400	73 - 423	54	63 - 300	3,30	380
E4.42	42	50 - 400	76 - 426	64	75 - 350	4,00	386
E4.56	56	50 - 600	84 - 634	84	135 - 500	5,00	392
E4.80	80	50 - 600	100 - 650	108	150 - 1000	6,20	398
E4.112 <b>New*</b>	112	50 - 600	102 - 652	140	200 - 1000	6,50	404
800	200	200 - 600	260 - 660	236	325 - 1000	8,00	410
840	204	100 - 563	160 - 623	236	325 - 1000	8,00	414
E4.350	350	400 - 800	540 - 940	450	500 - 1000	6,20	418



## Crossbars every 2<sup>nd</sup> link

e-chains® for almost all applications - Standard

H4.32	32	50 - 400	73 - 423	54	63 - 300	3,30	380
H4.42	42	50 - 400	76 - 426	64	75 - 350	4,00	386
H4.56	56	50 - 600	84 - 634	84	135 - 500	5,00	392
H4.80	80	50 - 600	100 - 650	108	150 - 1000	6,20	398
H4.112 <b>New*</b>	112	50 - 600	102 - 652	140	200 - 1000	6,50	404



## e-tubes

fully enclosed,  
excellent cable protection

R4.28	28	50 - 300	70 - 320	42	75 - 250	2,50	374
R4.32	32	50 - 300	73 - 323	54	125 - 300	3,30	380
R4.42	42	50 - 300	76 - 326	64	125 - 350	4,00	386
R4.56	56	75 - 462	109 - 497	84	135 - 500	5,00	392
R4.80	80	150 - 462	200 - 513	108	200 - 1000	6,20	398
R4.112 <b>New*</b>	108	200 - 400	252 - 452	140	250 - 1000	6,50	404

\* in this catalog



# E4.1 | Technical Data | Overview

## Technical Data



Gliding speed / acceleration (maximum) max. 10 [m/s] / max. 50 [m/s<sup>2</sup>]

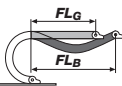

Speed / acceleration  $FL_G$  max. max. 20 [m/s] / max. 200 [m/s<sup>2</sup>]

Speed / acceleration  $FL_B$  max. max. 3 [m/s] / max. 6 [m/s<sup>2</sup>]



Material - permitted temperature °C, igumid G / GLW -40° up to +100° C



Flammability class, igumid G / GLW VDE 0304 IIC UL94-HB

■  $FL_G$  = with straight upper run ■  $FL_B$  = with permitted sag







## Installation methods overview, maximum travels

e-chain® / e-tube Series	Unsupported application	Gliding application	Vertical hanging	Vertical standing	Side mounted unsupported	Rotary application	Zig-zag application	Unsupp. length of lower run
E4.21	≤ 2,5 m	≤ 120 m	≤ 40 m	≤ 3,0 m	≤ 1,0 m	with rework	upon request	upon request
E4.28/R4.28	≤ 2,5 m	≤ 200 m	≤ 80 m	≤ 5,0 m	≤ 1,2 m	with rework	upon request	upon request
E4.32/H4.32/R4.32	≤ 3,3 m	≤ 200 m	≤ 80 m	≤ 5,0 m	≤ 1,5 m	with rework	upon request	upon request
E4.42/H4.42/R4.42	≤ 4,0 m	≤ 300 m	≤ 100 m	≤ 6,0 m	≤ 2,0 m	with rework	upon request	upon request
E4.56/H4.56/R4.56	≤ 5,0 m	≤ 400 m	≤ 100 m	≤ 6,0 m	≤ 2,5 m	with rework	upon request	upon request
E4.80/H4.80/R4.80	≤ 6,2 m	≤ 400 m	≤ 120 m	≤ 6,0 m	≤ 3,0 m	with rework	upon request	upon request
E4.112/H4.112/R4.112*	≤ 6,5 m	≤ 450 m	≤ 120 m	≤ 6,0 m	≤ 3,0 m	with rework	upon request	upon request
800	≤ 8,0 m	≤ 450 m	≤ 120 m	≤ 6,0 m	≤ 6,0 m	with rework	upon request	upon request
840	≤ 8,0 m	≤ 450 m	≤ 120 m	≤ 6,0 m	≤ 6,0 m	with rework	upon request	upon request
E4.350	upon request	upon request	upon request	upon request	upon request	with rework	upon request	upon request

\* **New** in this catalog

# E4.1 | Order keys and Options

## Options with order keys | based on Series E4.56/H4.56/R4.56

 <b>Standard</b>	<i>Additional noise dampening with pads</i>	<i>QuickLock crossbar - reduce assembly time up to 25%</i>		
<b>Part No. Standard</b> e-chains®/e-tubes	<b>Part No. Low noise (with pads)</b> e-chains®/e-tubes	<b>Part No. QuickLock crossbar for inner radius</b>	<b>Part No. QuickLock crossbar for outer radius</b>	<b>Part No. QuickLock crossbar for both radii</b>
			QuickLock crossbars: inner widths from Bi 15 (150 mm)	
 <b>E4.56.30.R.0</b> Crossbar every link	<b>ES4.56.30.R.0</b> Crossbar every link	<b>E4.56.30QZ.R.0</b> Crossbar every link	<b>E4.56.30QE.R.0</b> Crossbar every link	<b>E4.56.30Q.R.0</b> Crossbar every link
<b>H4.56.30.R.0</b> Crossbar every 2 <sup>nd</sup> link	<b>HS4.56.30.R.0</b> Crossbar every 2 <sup>nd</sup> link	<b>H4.56.30QZ.R.0</b> Crossbar every 2 <sup>nd</sup> link	<b>H4.56.30QE.R.0</b> Crossbar every 2 <sup>nd</sup> link	<b>H4.56.30Q.R.0</b> Crossbar every 2 <sup>nd</sup> link
<b>R4.56.30.R.0</b> e-tube, closed	<b>RS4.56.30.R.0</b> e-tube, closed			
 <b>Delivery from stock</b>	<b>Delivery time: upon request</b>	<b>Delivery time: upon request</b>	<b>Delivery time: upon request</b>	<b>Delivery time: upon request</b>

## Order example | based on Series E4.56/H4.56/R4.56

 **Order example for complete e-chain® (3,0 m, with crossbars every link), color black, mounting brackets and interior separation**

<b>e-chain® (3,0 m)</b>	Please indicate e-chain® length or number of links: 3,0 m or 33 links	<b>E4.56.30.300.0</b>
<b>+ Mounting brackets</b>	KMA - 1 set (with odd number of links and integrated C-profiles)	<b>E4.560.30.1.12.C</b>
<b>+ Interior separation</b>	with 2 separators assembled every 2 <sup>nd</sup> link	<b>2 x 56.1.1</b>

Order text: 3,0 m E4.56.30.300.0 + E4.560.30.1.12.C + 2 x Part No. 56.1.1

### Magnetically detectable plastic e-chains®

**For the food- and tobaccoindustry | New** in this catalog

● The material igumid DT is detected to the tiniest fragment all common metal detection systems and can therefore be selected automatically ● Particles as small as 1.0 mm can be recognized for fragments passing at speeds of 20 m/min

Further Information ► [www.igus.eu/eu/detectablechain](http://www.igus.eu/eu/detectablechain)

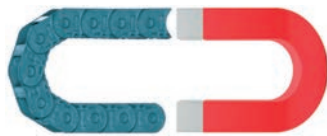

# E4.1 | Order keys and Options

Simply turn outer side link without additional work

Part No.

**NC-Version**

e-chains®/e-tubes



Reverse bending radius for circular movements

Part No.

**RBR**

e-chains®/e-tubes



Unsupported lengths +25% possible

Part No.

**XXL-Material 1)**

e-chains®/e-tubes



No burning-in of hot chips up to 850°C (1562°F)

Part No.

**igumid HT-Material**  
only for e-tubes



ESD / ATEX classified e-chains®

Part No.

**ESD-Material**

e-chains®/e-tubes



Magnetically detectable plastic e-chains®

Part No.

**igumid DT-Material**

e-chains®/e-tubes



**E4.56.30.R.0.NC**

Crossbar every link

**E4.56.30.R1/R2.0**

Crossbar every link

**E4.56.30.R.0.XXL**

Crossbar every link

**R4.56.30.R.0.HT**

Complete e-tube<sup>2)</sup>

**E4.56.30.R.0.ESD**

Crossbar every link

**E4.56.30.R.0.DT**

Crossbar every link

**H4.56.30.R.0.NC**

Crossbar every 2<sup>nd</sup> link

**H4.56.30.R1/R2.0**

Crossbar every 2<sup>nd</sup> link

**H4.56.30.R.0.XXL**

Crossbar every 2<sup>nd</sup> link

**R4.56.30.HT.R.0**

Lid and bottom

**H4.56.30.R.0.ESD**

Crossbar every 2<sup>nd</sup> link

**H4.56.30.R.0.DT**

Crossbar every 2<sup>nd</sup> link

**R4.56.30.R.0.NC**

e-tube, closed

**R4.56.30.R1/R2.0**

e-tube, closed

**R4.56.30.R.0.XXL**

e-tube, closed

**R4.56.30.HTZ.R.0**

Bottom only

**R4.56.30.R.0.ESD**

e-tube, closed

**R4.56.30.R.0.DT**

e-tube, closed

**R4.56.30.HTE.R.0**

Lid only

**Delivery time: upon request**

**Delivery time: upon request**

*(2-5 work days with express surcharge)*

**Delivery time: upon request**

*1) Sidebands made from XXL-Material*

**Delivery time: upon request**

*2) for gliding applications please consult igus®*

**Delivery time: Several series from stock**

**Delivery time: upon request**

*3) for the food- and tobacco industry*

## Order key and color options | based on Series E4.56/H4.56/R4.56



### Order key

e-chain® crossbars every link

e-chain® crossbars every 2<sup>nd</sup> link

e-tube fully enclosed

Series / Type

Inner height

Width index (depends on *Bi*)

Bending radius *R*

Color index (standard black)

**E4.56.30.300.0**

**H4.56.30.300.0**

**R4.56.30.300.0**

**H4.56.30.300.0**

**R4.56.30.300.0**

**H4.56.30.300.0**

**R4.56.30.300.0**

**H4.56.30.300.0**

**R4.56.30.300.0**

### General igus® color options for e-chains® and e-tubes

Color	Order index	Color	Order index
■ <b>Black</b> Standard, from stock!	<b>.0</b>	□ <b>White</b> special color	<b>.1</b>
■ <b>Slate grey</b> only ESD material	<b>.ESD</b>	□ <b>Gray white</b> special color	<b>.1S</b>
■ <b>Gray brown</b> only HT material	<b>.HT</b>	■ <b>Orange</b> special color	<b>.2</b>
■ <b>Gray</b> special color only e-chains®	<b>.3</b>	■ <b>Yellow</b> special color	<b>.4</b>
■ <b>Dusty grey</b> special color only e-tubes	<b>.31</b>	■ <b>Light grey</b> special color	<b>.14</b>

**Black e-chains® available from stock!**

**Delivery time for special colors: upon request**

**E4.56.30.300.0** = e-chain® with crossbars every link, inner width *Bi* 300 mm, radius *R* 300 mm, color black

**H4.56.30.300.0** = e-chain® with crossbars every 2<sup>nd</sup> link, inner width *Bi* 300 mm, radius *R* 300 mm, color black

**R4.56.30.300.0** = e-tube fully enclosed, inner width *Bi* 300 mm, radius *R* 300 mm, color black

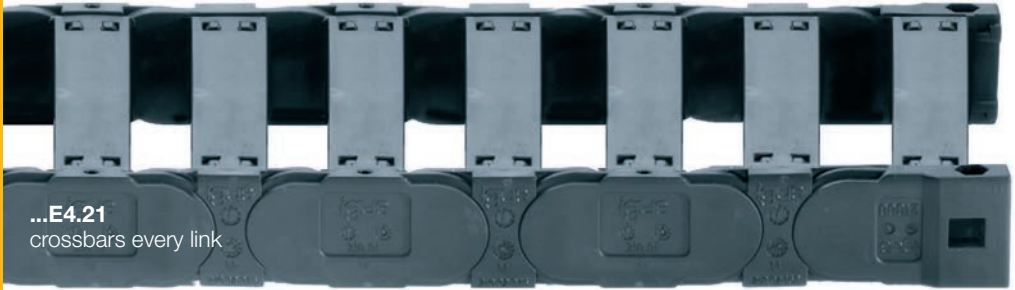

### e-chains® | Series E4.21 crossbars every link (crossbars removable along both radii)

Part No. e-chains®	<i>Bi</i> [mm]	<i>Ba</i> [mm]	E4.21 [kg/m]	Part No. e-chains®	<i>Bi</i> [mm]	<i>Ba</i> [mm]	E4.21 [kg/m]
E4.21.030. R.0	30	44	≈ 0,60	E4.21.090. R.0	90	104	≈ 0,82
E4.21.040. R.0	40	54	≈ 0,64	E4.21.100. R.0	100	114	≈ 0,85
E4.21.050. R.0	50	64	≈ 0,67	E4.21.110. R.0	110	124	≈ 0,89
E4.21.060. R.0	60	74	≈ 0,71	E4.21.120. R.0	120	134	≈ 0,92
E4.21.070. R.0	70	84	≈ 0,74	E4.21.140. R.0	140	154	≈ 0,99
E4.21.080. R.0	80	94	≈ 0,78				

Available bending radii  $R$  [mm] 038 | 048 | 063 | 075 | 100 | 150 | 200

Supplement Part No. with required radius ( $R$ ). Example:

E4.21.120.100.0 = e-chain® with crossbars every link, inner width  $Bi$  120 mm, radius  $R$  100 mm, color black



ESD/ATEX permanently conductive e-chains® - E4.21 several widths with delivery from stock: Inner widths  $Bi$  30 - 70, radii  $R$  48 - 100. Full ESD delivery program ► [www.igus.eu/eu/ESD](http://www.igus.eu/eu/ESD)



## Unsupported applications | Short travels

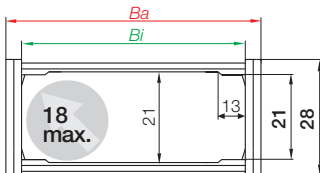
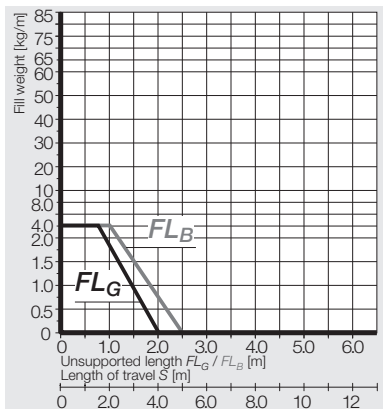

Inner height 21 mm  
 Pitch 30,5 mm/link  
 Links/m 33 (1007 mm)  
 Chain length  $s/2 + K$

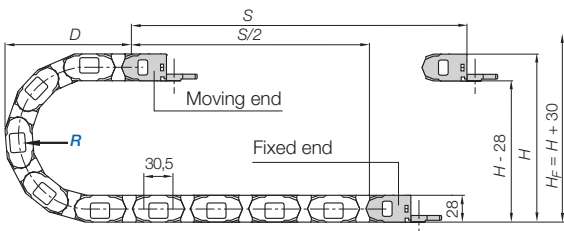

$R$	038	048	063	075	100	150	200
$H$	104	124	154	178	228	328	428
$D$	98	108	123	135	160	210	260
$K$	185	215	260	300	380	535	690

The required clearance height:  $H_F = H + 30$  mm (with 1,5 kg/m fill weight)

## Gliding applications | Long travels from 10 m to max. 120 m

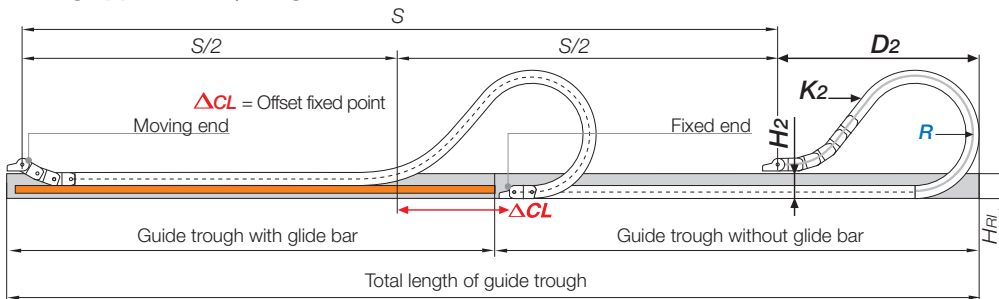

**Note:** For long travel applications with more than 100 m we recommend to realize the engineering of such a plant by our technicians. In case of travels between 4 and 10 m we recommend a longer unsupported length. **Chain length**  $s/2 + K_2$

$R$	038	048	063	075	100	150	200
$H_2$	76	96	126	152	135	135	135
$D_2^{+25}$	085	095	110	120	490	530	665
$K_2$	185	215	260	300	782	920	1104
$\Delta CL$	-	-	-	-	270	370	470

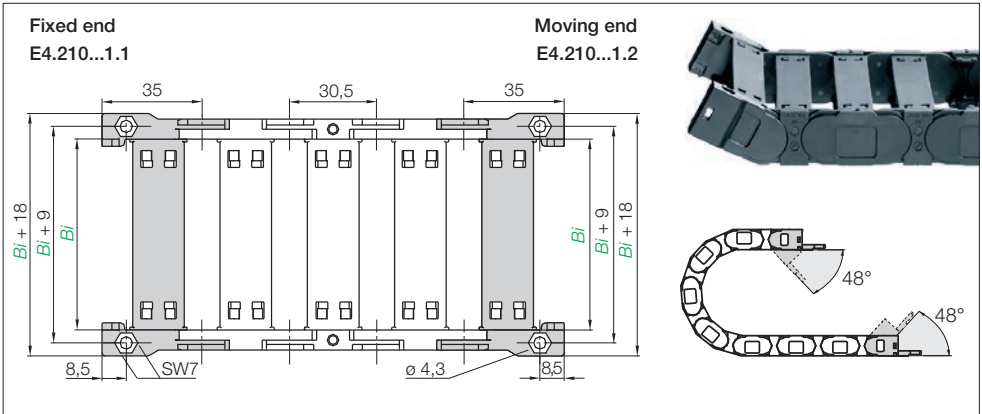

### KMA pivoting | Recommended for unsupported and gliding applications

Width Index	Part No. full set KMA pivoting:	Bi [mm]	Width Index	Part No. full set KMA pivoting:	Bi [mm]
030.	▶ E4.210. 030.1.12	30	090.	▶ E4.210. 090.1.12	90
040.	▶ E4.210. 040.1.12	40	100.	▶ E4.210. 100.1.12	100
050.	▶ E4.210. 050.1.12	50	110.	▶ E4.210. 110.1.12	110
060.	▶ E4.210. 060.1.12	60	120.	▶ E4.210. 120.1.12	120
070.	▶ E4.210. 070.1.12	70	140.	▶ E4.210. 140.1.12	140
080.	▶ E4.210. 080.1.12	80			

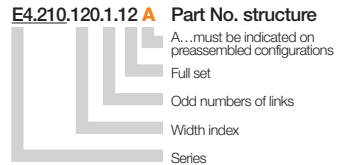

#### Special feature mounting brackets - E4.21

- Special design of the counterbore as hexagon - the inlay of the nut (M4) and the counterboring of the hexagon socket head screw (M4), is consequently possible
- **Note:** E4.21 mounting brackets with attachment points on all sides always need to end with an inner plate (odd number of links). For the **preassembled** mode please add index **A**.

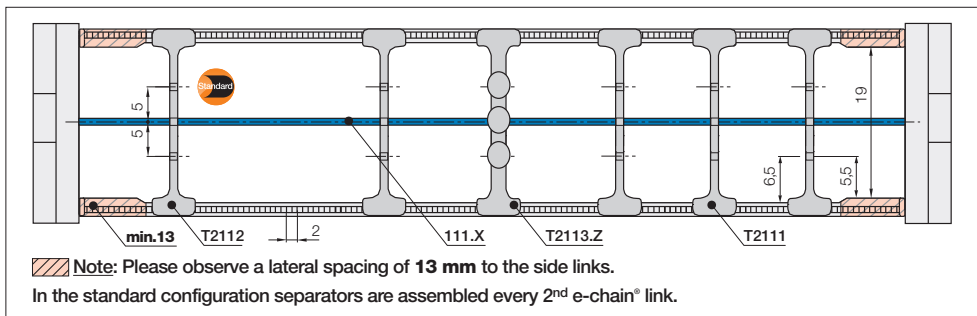

**Strain relief** e.g. clamps, tiewrap plates, nuggets and plug-in clips are available from stock. The complete chainfix range with order options ▶ from page 630

## Interior separation

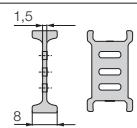
**Separator for e-chains®**  
unassembled **T2102**  
assembled **T2112**

### Standard separator T2102

is used when vertical and horizontal separation is required. Due to its slot, it allows basic vertical/horizontal shelving arrangements.

**Notch separator for e-chains®**  
unassembled **T2101**  
assembled **T2111**

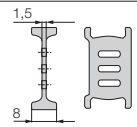
### Notch separator T2101

can be locked in 2 mm increments due to gaps on the crossbars of e-chains®. The separator cannot slide sideways during the operation.

**Full-width shelf (30-120 mm)**  
unassembled **110.X**  
assembled **111.X**

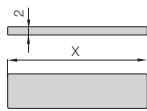
### Full-width shelf 110.X

this option makes sense in applications with many thin cables with similar diameters. Full-width shelves can be arranged at 3 different heights (in 5 mm increments).

### Full-width shelf

Width X [mm]	unassembled	assembled	Width X [mm]	unassembled	assembled	Width X [mm]	unassembled	assembled
030	110.30	111.30	070	110.70	111.70	110	110.110	111.110
040	110.40	111.40	080	110.80	111.80	120	110.120	111.120
050	110.50	111.50	090	110.90	111.90			
060	110.60	111.60	100	110.100	111.100			

### Separator with integrated strain relief

Strain relief separator Part No. T2103.Z can be integrated into the mounting bracket and can be placed there at any point of the e-chain®. It combines strain relief and interior separation, it can be installed on the first or last chain link and is easy to assemble without any screws. **Further Information ► from page 650**



### Optional: Support tray tool kit.

#### For support of the lower run.

Simple one-piece support trays according to your requirements and specification.

The complete range with order options ► from page 714



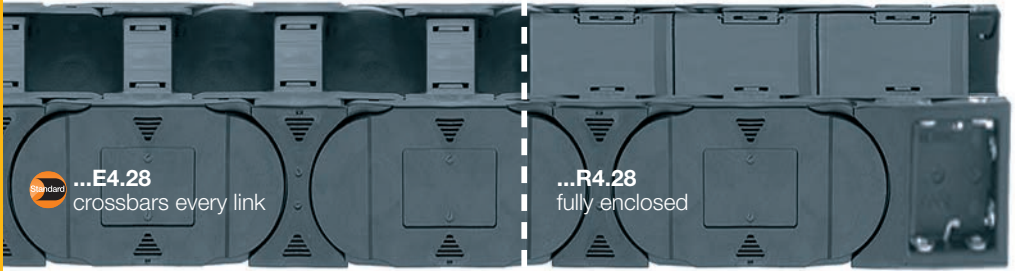
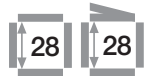

**e-chains® | Series E4.28 crossbars every link** (crossbars removable along both radii)  
**e-tubes | Series R4.28 fully enclosed** (hinged snap-open removable lids along outer radius)

Part No. e-chains® / e-tubes	<i>Bi</i> [mm]	<i>Ba</i> [mm]	E4.28 [kg/m]	R4.28 [kg/m]	Part No. e-chains® / e-tubes	<i>Bi</i> [mm]	<i>Ba</i> [mm]	E4.28 [kg/m]	R4.28 [kg/m]
E4. – 28.040.R.0	40	60	≈ 1,06	–	E4. R4.28. 150. R.0	150	170	≈ 1,61	≈ 3,02
E4. R4.28. 050. R.0	50	70	≈ 1,11	≈ 2,20	E4. R4.28. 175. R.0	175	195	≈ 1,71	≈ 3,26
E4. – 28.062.R.0	62	82	≈ 1,17	–	E4. R4.28. 200. R.0	200	220	≈ 1,84	≈ 3,50
E4. – 28.070.R.0	70	90	≈ 1,20	–	E4. R4.28. 225. R.0	225	245	≈ 1,99	≈ 3,82
E4. R4.28. 075. R.0	75	95	≈ 1,23	≈ 2,32	E4. R4.28. 250. R.0	250	270	≈ 2,14	≈ 3,98
E4. – 28.087.R.0	87	107	≈ 1,28	–	E4. – 28.275. R.0	275	295	≈ 2,27	–
E4. R4.28. 100. R.0	100	120	≈ 1,37	≈ 2,54	E4. R4.28. 300. R.0	300	320	≈ 2,39	≈ 4,46
E4. R4.28. 125. R.0	125	145	≈ 1,51	≈ 2,78					

\*Radius not available for e-tubes

Available bending radii *R* [mm] 055\* | 063\* | 075 | 100 | 125 | 150 | 175 | 200 | 250

Supplement Part No. with required radius (*R*). Examples:

E4.28.100.100.0 = e-chain® with **crossbars every link**, inner width *Bi* 100 mm, radius *R* 100 mm, color black

R4.28.100.100.0 = e-tube **fully enclosed**, inner width *Bi* 100 mm, radius *R* 100 mm, color black



ESD/ATEX permanently conductive e-chains® - E4.28 several widths with delivery from stock:  
 Inner widths *Bi* 40 - 125, radii *R* 55 - 125. Full ESD delivery program ► [www.igus.eu/eu/ESD](http://www.igus.eu/eu/ESD)





## Unsupported applications | Short travels

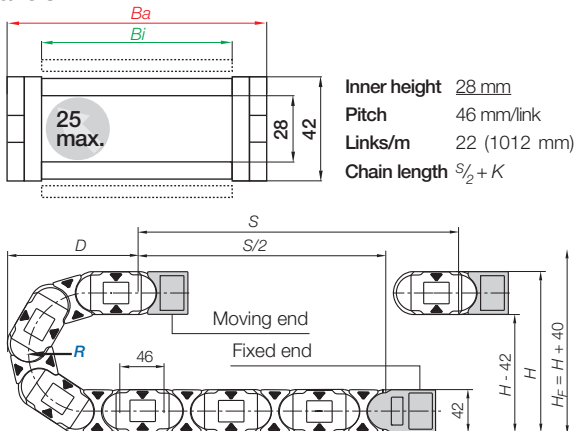
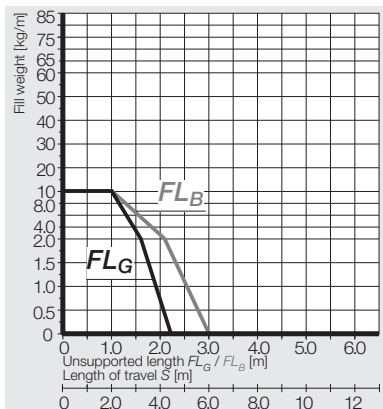

	055	063	075	100	125	150	175	200	250
<b>R</b>	055	063	075	100	125	150	175	200	250
<b>H</b>	152	168	192	242	292	342	392	442	542
<b>D</b>	145	153	165	190	215	240	265	290	340
<b>K</b>	265	290	330	410	485	565	645	725	880

The required clearance height:  $H_F = H + 40$  mm (with 1,0 kg/m fill weight)

\*Radius not available for e-tubes

## Gliding applications | Long travels from 10 m to max. 200 m

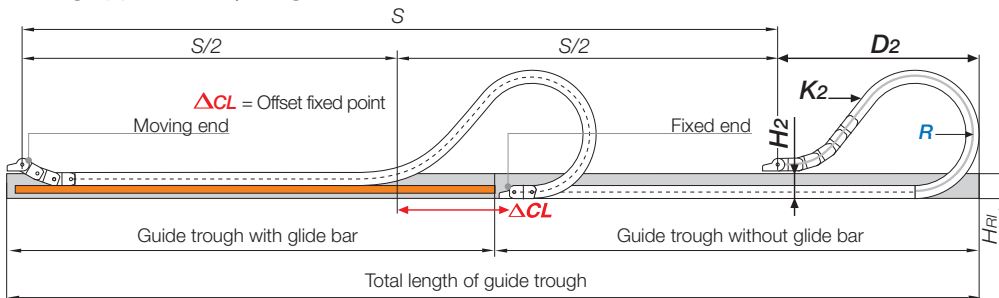

**Note:** For long travel applications with more than 100 m we recommend to realize the engineering of such a plant by our technicians. In case of travels between 5 and 10 m we recommend a longer unsupported length. **Chain length**  $S/2 + K_2$

	055*	063*	075	100	125	150	175	200	250
<b>H<sub>2</sub></b>	110	126	150	158	158	158	158	158	158
<b>D<sub>2</sub>+25</b>	122	130	142	350	490	530	665	730	935
<b>K<sub>2</sub></b>	265	290	330	598	782	920	1104	1242	1610
<b>ΔCL</b>	-	-	-	150	270	300	400	450	600

\*Radius not available for e-tubes

# E4.1 | Series E4.28 | Accessories

KMA mounting brackets | Attachment on all sides | pivoting | locking

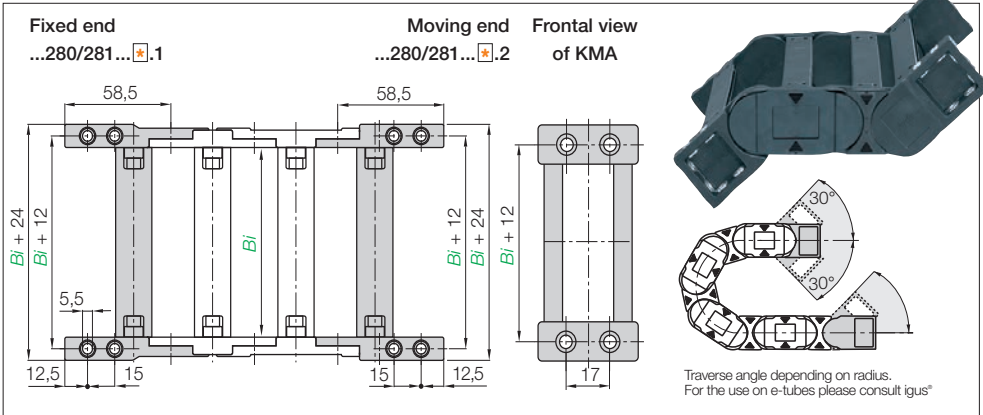



**KMA pivoting** | Standard | Recommended for unsupported and gliding applications  
**KMA locking** | Recommended for vertical hanging and standing applications

Width Index	Standard	Part No. full set KMA pivoting:	Part No. full set KMA locking:	Bi [mm]	Width Index	Standard	Part No. full set KMA pivoting:	Part No. full set KMA locking:	Bi [mm]
040.	▶	E4. - 280.040. 1.12	E4. - 281.040. 2.12	40	150.	▶	E4. R4. 280.150. 1.12	E4. R4. 281.150. 2.12	150
050.	▶	E4. R4. 280.050. 1.12	E4. R4. 281.050. 1.12	50	175.	▶	E4. R4. 280.175. 1.12	E4. R4. 281.175. 1.12	175
062.	▶	E4. - 280.062. 1.12	E4. - 281.062. 1.12	62	200.	▶	E4. R4. 280.200. 1.12	E4. R4. 281.200. 1.12	200
070.	▶	E4. - 280.070. 1.12	E4. - 281.070. 1.12	70	225.	▶	E4. R4. 280.225. 1.12	E4. R4. 281.225. 1.12	225
075.	▶	E4. R4. 280.075. 1.12	E4. R4. 281.075. 1.12	75	250.	▶	E4. R4. 280.250. 1.12	E4. R4. 281.250. 1.12	250
087.	▶	E4. - 280.087. 1.12	E4. - 281.087. 1.12	87	275.	▶	E4. - 280.275. 1.12	E4. - 281.275. 1.12	275
100.	▶	E4. R4. 280.100. 1.12	E4. R4. 281.100. 1.12	100	300.	▶	E4. R4. 280.300. 1.12	E4. R4. 281.300. 1.12	300
125.	▶	E4. R4. 280.125. 1.12	E4. R4. 281.125. 1.12	125					

**Note**\*: The E4.1 may end with either an inner or an outer side link. An outer side link always forms the first e-chain® link at the moving end. The Part No. depend on an even or odd numbers of links. Please insert: Index **1** (for odd) or **2** (for even). For the **preassembled** mode please add index **A**.

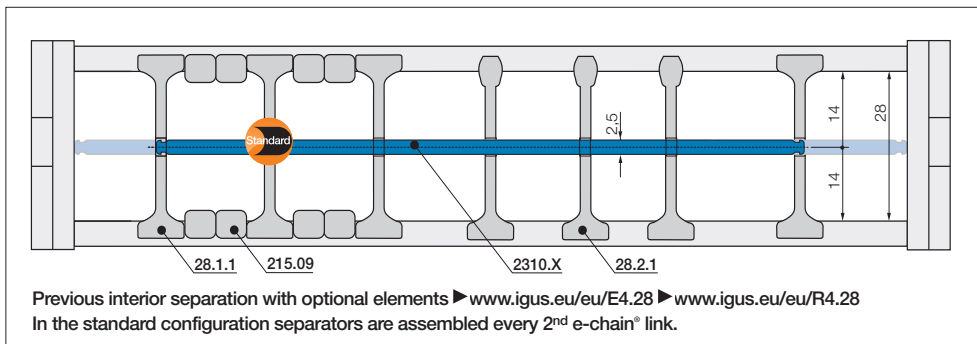

**Strain relief** e.g. clamps, tiewrap plates, nuggets and plug-in clips are available from stock. The complete chainfix range with order options ▶ from page 630





**Standard separator, wide base**

unassembled	<b>28.1</b>
assembled	<b>28.1.1</b>

**Standard - for all applications**

Separator with wide base for maximum locking strength and safe standing in e-chains®.



**Separator, narrow head**

unassembled	<b>28.2</b>
assembled	<b>28.2.1</b>

**For even faster installation**

Firm hold to one side with a wide base, narrow on opposed side for easy cable assembly (slight grip).



**Spacer for e-chains®**

unassembled	<b>205.09</b>
assembled	<b>215.09</b>

**Spacer 205.09**

Separators can be fixed in position by spacers. The available interior height is reduced by 2 mm per spacer (4 mm when spacers are fitted on both sides). To avoid this, the parts can also be installed from the outside on the opening crossbar. (not for long travel applications).



**Full-width shelf, lockable**

unassembled	<b>2300.X</b>
assembled	<b>2310.X</b>

**Horizontal separation**

Full-width shelf locks safely into separators on both ends, fixed width possible. Separators can be moved freely over the shelf in horizontal direction. Can be used at one height.

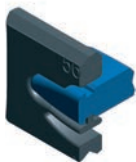



**Lockable full-width shelves - for the standard interior separation**

Width X [mm]	unassembled	assembled	Width X [mm]	unassembled	assembled	Width X [mm]	unassembled	assembled
015	<b>2300.015</b>	<b>2310.015</b>	060	<b>2300.060</b>	<b>2310.060</b>	087	<b>2300.87</b>	<b>2310.087</b>
025	<b>2300.025</b>	<b>2310.025</b>	062	<b>2300.062</b>	<b>2310.062</b>	090	<b>2300.90</b>	<b>2310.090</b>
030	<b>2300.030</b>	<b>2310.030</b>	065	<b>2300.065</b>	<b>2310.065</b>	100	<b>2300.100</b>	<b>2310.100</b>
038	<b>2300.038</b>	<b>2310.038</b>	070	<b>2300.070</b>	<b>2310.070</b>	103	<b>2300.103</b>	<b>2310.103</b>
040	<b>2300.040</b>	<b>2310.040</b>	075	<b>2300.075</b>	<b>2310.075</b>	110	<b>2300.110</b>	<b>2310.110</b>
050	<b>2300.050</b>	<b>2310.050</b>	077	<b>2300.077</b>	<b>2310.077</b>	120	<b>2300.120</b>	<b>2310.120</b>
057	<b>2300.057</b>	<b>2310.057</b>	080	<b>2300.080</b>	<b>2310.080</b>	125	<b>2300.125</b>	<b>2310.125</b>

# E4.1 | Series E4.28 | Accessories

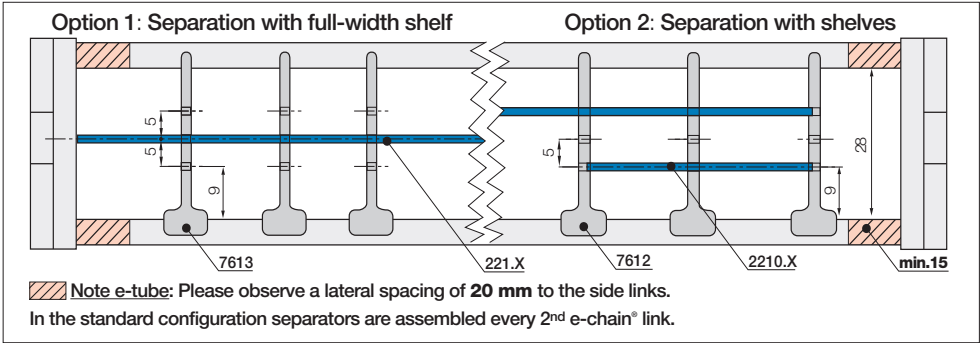
Interior separation | Only for e-tubes (e-chains® ► previous page)





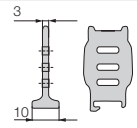

**Separator for e-tubes**

unassembled **7603**

assembled **7613**

---



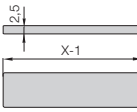

**Full-width shelf (40-200 mm)**

unassembled **220.X**

assembled **221.X**

### Separator 7603 (e-tubes only)

is used when vertical and horizontal separation is required. Due to its slot, it allows basic vertical/horizontal shelving arrangements.

### Full-width shelf 220.X

This option makes sense in applications with many thin cables with similar diameters. Full-width shelves can be arranged at 3 different heights (in 5 mm increments).

### Full-width shelf

Width X [mm]	unassembled	assembled	Width X [mm]	unassembled	assembled	Width X [mm]	unassembled	assembled
040	220.40	221.40	075	220.75	221.75	150	220.150	221.150
050	220.50	221.50	087	220.87	221.87	175	220.175	221.175
062	220.62	221.62	100	220.100	221.100	200	220.200	221.200
070	220.70	221.70	125	220.125	221.125			



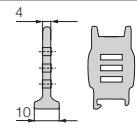

**Middle plate for e-tubes**

unassembled **7602**

assembled **7612**

---



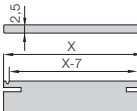

**Shelf (18-149 mm)**

unassembled **2200.X**

assembled **2210.X**

### Middle plate 7602 (e-tubes only)

To achieve a modular shelving by shelf 2200.X arranged at 3 different heights (in 5 mm increments).

### Shelf 2200.X

For horizontal separation. Shelves of various widths can be arranged at 3 different heights (in 5 mm increments).

### Shelves

Width X [mm]	unassembled	assembled	Width X [mm]	unassembled	assembled	Width X [mm]	unassembled	assembled
018	2200.18	2210.18	043	2200.43	2210.43	088	2200.88	2210.088
023	2200.23	2210.23	048	2200.48	2210.48	099	2200.99	2210.099
028	2200.28	2210.28	058	2200.58	2210.58	124	2200.124	2210.124
033	2200.33	2210.33	068	2200.68	2210.68	149	2200.149	2210.149
038	2200.38	2210.38	073	2200.73	2210.73			

## Optional: **Support tray tool kit.**

### For support of the lower run.

Simple one-piece support trays according to your requirements and specification.  
The complete range with order options ► from page 714

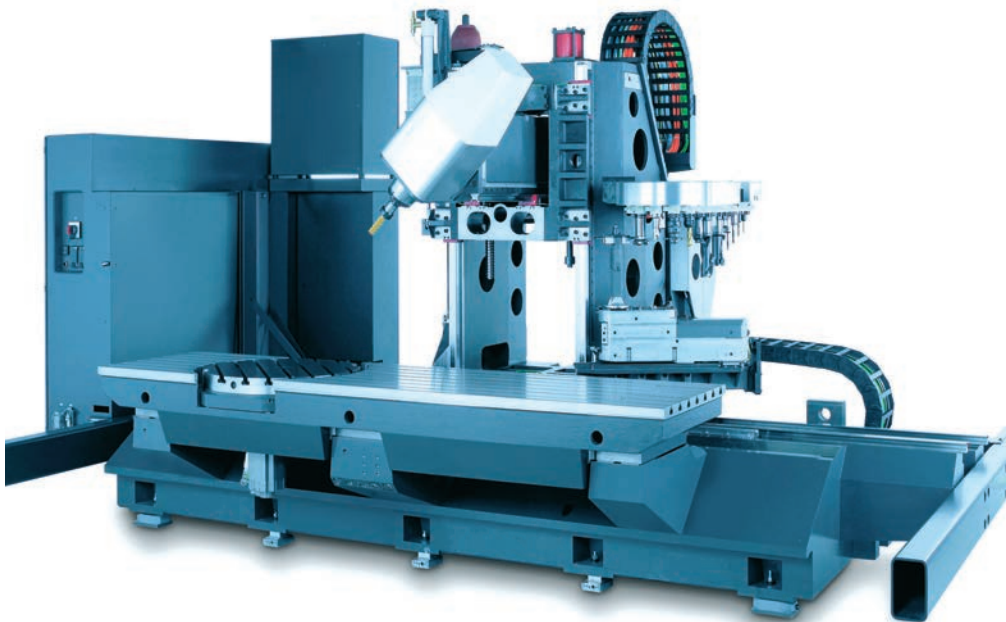

Due to the "undercut design" igus® E4.1 series feature high lateral stability.  
High lateral accelerations of up to 8 m/s<sup>2</sup> can be managed on this milling machine for bicycles

# E4.1 | Series E4.32 | Delivery program

Stable due to undercut design, medium inner height

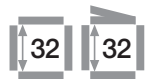

e-chains® | Series E4.32 crossbars every link (crossbars removable along both radii)  
 e-chains® | Series H4.32 crossbars every 2<sup>nd</sup> link (crossbars removable along both radii)  
 e-tubes | Series R4.32 fully enclosed (hinged snap-open removable lids along outer radius)

Part No. e-chains® / e-tubes	<i>Bi</i> [mm]	<i>Ba</i> [mm]	E4.32 [kg/m]	H4.32 [kg/m]	R4.32 [kg/m]
E4. H4. R4.1) 32. 05. R.0	50	73	1,567	1,425	2,450
E4. H4. - 32. 06. R.0	68	91	1,697	1,49	-
E4. H4. R4. 32. 07. R.0	75	98	1,730	1,507	2,570
E4. H4. - 32. 087.R.0	87	110	1,803	1,543	-
E4. H4. - 32. 097.R.0	97	120	1,867	1,575	-
E4. H4. R4. 32. 10. R.0	100	123	1,886	1,584	2,650
E4. H4. R4. 32. 11. R.0	108	131	1,942	1,612	2,760
E4. H4. - 32. 112.R.0	112	136	1,956	1,619	-
E4. H4. R4. 32. 12. R.0	125	148	2,069	1,676	2,850
E4. H4. - 32. 137.R.0	137	161	2,122	1,702	-
E4. H4. R4. 32. 15. R.0	150	173	2,212	1,747	3,010
E4. H4. - 32. 162.R.0	162	186	2,240	1,762	-
E4. H4. R4. 32. 17. R.0	168	191	2,323	1,803	3,210
E4. H4. - 32. 18. R.0	175	198	2,345	1,814	-
E4. H4. - 32. 187.R.0	187	211	2,392	1,837	-
E4. H4. R4. 32. 20. R.0	200	223	2,518	1,900	3,410

Part No. e-chains® / e-tubes	<i>Bi</i> [mm]	<i>Ba</i> [mm]	E4.32 [kg/m]	H4.32 [kg/m]	R4.32 [kg/m]
E4. H4. - 32. 212.R.0	212	236	2,568	1,925	-
E4. H4. - 32. 23. R.0	225	248	2,669	1,976	-
E4. H4. - 32. 237.R.0	237	261	2,698	1,990	-
E4. H4. R4. 32. 25. R.0	250	273	2,834	2,059	3,860
E4. H4. - 32. 262.R.0	262	286	2,917	2,100	-
E4. H4. - 32. 28. R.0	275	298	2,989	2,136	-
E4. H4. - 32. 29. R.0	287	311	3,023	2,153	-
E4. H4. R4. 32. 30. R.0	300	323	3,151	2,217	4,250
E4. H4. - 32. 312.R.0	312	336	3,175	2,229	-
E4. H4. - 32. 325.R.0	325	348	3,277	2,280	-
E4. H4. - 32. 337.R.0	337	361	3,338	2,311	-
E4. H4. - 32. 350.R.0	350	373	3,565	2,424	-
E4. H4. - 32. 362.R.0	362	386	3,662	2,473	-
E4. H4. - 32. 375.R.0	375	398	3,735	2,509	-
E4. H4. - 32. 387.R.0	387	411	3,803	2,543	-
E4. H4. - 32. 400.R.0	400	423	3,868	2,575	-

\*Radius not available for e-tubes 1) Removable lid only, no hinged option

Available bending radii *R* [mm] 063\* | 075\* | 100\* | 125 | 150 | 175 | 200 | 220 | 250 | 300

Supplement Part No. with required radius (*R*). Examples:

E4.32.30.300.0 = e-chain® with crossbars every link, inner width *Bi* 300 mm, radius *R* 300 mm, color black

H4.32.30.300.0 = e-chain® with crossbars every 2<sup>nd</sup> link, inner width *Bi* 300 mm, radius *R* 300 mm, color black

R4.32.30.300.0 = e-tube fully enclosed, inner width *Bi* 300 mm, radius *R* 300 mm, color black



ESD/ATEX permanently conductive e-chains® - E4.32 several widths with delivery from stock:  
 Inner widths *Bi* 50 - 200, radii *R* 63 - 250. Full ESD delivery program ► [www.igus.eu/eu/ESD](http://www.igus.eu/eu/ESD)



## Unsupported applications | Short travels

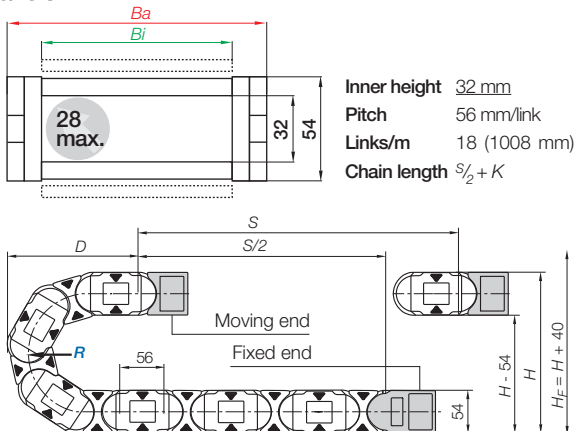
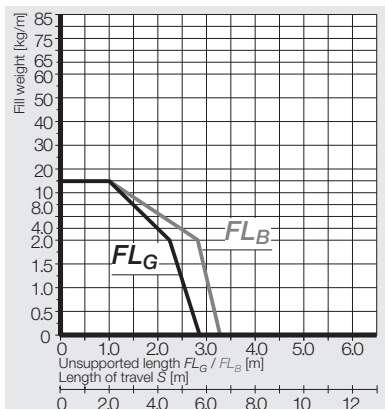

R	063	075	100	125	150	175	200	220	250	300
H + <sup>20</sup> <sub>0</sub>	180	204	254	304	354	404	454	494	554	654
D	174	186	211	236	261	286	311	331	361	411
K	310	350	430	505	585	665	745	805	900	1055

The required clearance height:  $H_F = H + 40$  mm (with 2,0 kg/m fill weight)

\*Radius not available for e-tubes

## Gliding applications | Long travels from 10 m to max. 200 m

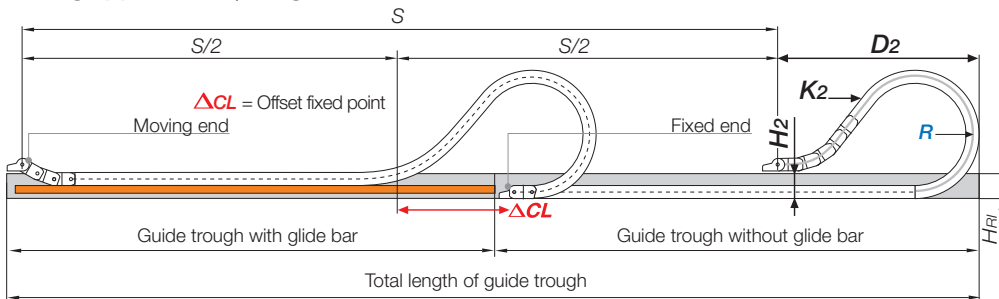

**Note:** For long travel applications with more than 100 m we recommend to realize the engineering of such a plant by our technicians. In case of travels between 7 and 10 m we recommend a longer unsupported length. **Chain length**  $S/2 + K_2$

R	063*	075*	100*	125	150	175	200	220	250	300
H <sub>2</sub>	126	150	166	166	166	166	166	166	166	166
D <sub>2</sub> + <sup>25</sup> <sub>0</sub>	146	158	370	470	500	655	770	900	930	1100
K <sub>2</sub>	310	350	616	784	896	1120	1288	1456	1568	1904
ΔCL	-	-	160	210	240	370	460	540	570	690

\*Radius not available for e-tubes

# E4.1 | Series E4.32 | Accessories

KMA mounting brackets | Attachment on all sides | pivoting | locking

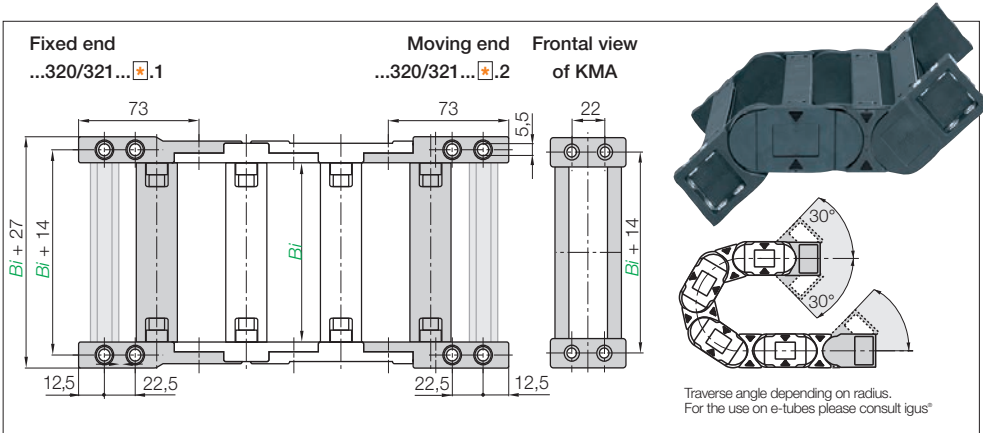

**KMA pivoting** | Standard | Recommended for unsupported and gliding applications  
**KMA locking** | Recommended for vertical hanging and standing applications

Width Index	Standard	Part No. full set KMA pivoting:	Part No. full set KMA locking:	Bi [mm]	Width Index	Standard	Part No. full set KMA pivoting:	Part No. full set KMA locking:	Bi [mm]
05.	▶	E4. R4.320.05 .12.C	E4. R4.321.05 .12.C	50	212.	▶	E4. - 320.212 .12.C	E4. - 321.212 .12.C	212
06.	▶	E4. - 320.06 .12.C	E4. - 321.06 .12.C	68	23.	▶	E4. - 320.23 .12.C	E4. - 321.23 .12.C	225
07.	▶	E4. R4.320.07 .12.C	E4. R4.321.07 .12.C	75	237.	▶	E4. - 320.237 .12.C	E4. - 321.237 .12.C	237
087.	▶	E4. - 320.087 .12.C	E4. - 321.087 .12.C	87	25.	▶	E4. R4.320.25 .12.C	E4. R4.321.25 .12.C	250
09.	▶	E4. - 320.097 .12.C	E4. - 321.09 .12.C	97	262.	▶	E4. - 320.262 .12.C	E4. - 321.262 .12.C	262
10.	▶	E4. R4.320.10 .12.C	E4. R4.321.10 .12.C	100	28.	▶	E4. - 320.28 .12.C	E4. - 321.28 .12.C	275
11.	▶	E4. R4.320.11 .12.C	E4. R4.321.11 .12.C	108	29.	▶	E4. - 320.29 .12.C	E4. - 321.29 .12.C	287
112.	▶	E4. - 320.112 .12.C	E4. - 321.112 .12.C	112	30.	▶	E4. R4.320.30 .12.C	E4. R4.321.30 .12.C	300
12.	▶	E4. R4.320.12 .12.C	E4. R4.321.12 .12.C	125	312.	▶	E4. - 320.312 .12.C	E4. - 321.312 .12.C	312
137.	▶	E4. - 320.137 .12.C	E4. - 321.137 .12.C	137	325.	▶	E4. - 320.325 .12.C	E4. - 321.325 .12.C	325
15.	▶	E4. R4.320.15 .12.C	E4. R4.321.15 .12.C	150	337.	▶	E4. - 320.337 .12.C	E4. - 321.337 .12.C	337
162.	▶	E4. - 320.162 .12.C	E4. - 321.162 .12.C	162	350.	▶	E4. - 320.350 .12.C	E4. - 321.350 .12.C	350
17.	▶	E4. R4.320.17 .12.C	E4. R4.321.17 .12.C	175	362.	▶	E4. - 320.362 .12.C	E4. - 321.362 .12.C	362
18.	▶	E4. - 320.18 .12.C	E4. - 321.18 .12.C	168	375.	▶	E4. - 320.375 .12.C	E4. - 321.375 .12.C	375
187.	▶	E4. - 320.187 .12.C	E4. - 321.187 .12.C	187	387.	▶	E4. - 320.387 .12.C	E4. - 321.387 .12.C	387
20.	▶	E4. R4.320.20 .12.C	E4. R4.321.20 .12.C	200	400.	▶	E4. - 320.400 .12.C	E4. - 321.400 .12.C	400

**Note\***: The E4.1 may end with either an inner or an outer side link. An outer side link always forms the first e-chain® link at the moving end. The Part No. depend on an even or odd numbers of links. Please insert: Index 1 (for odd) or 2 (for even). For the preassembled mode please add index A.

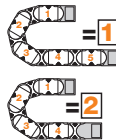

E4.320.30.2.12.CA Part No. structure

- A... must be indicated on preassembled configurations
- C-profile option
- Full set
- Even numbers of links
- Width index
- Series





**Strain relief** e.g. clamps, tiewrap plates, nuggets and plug-in clips are available from stock. The complete chainfix range with order options ▶ from page 630

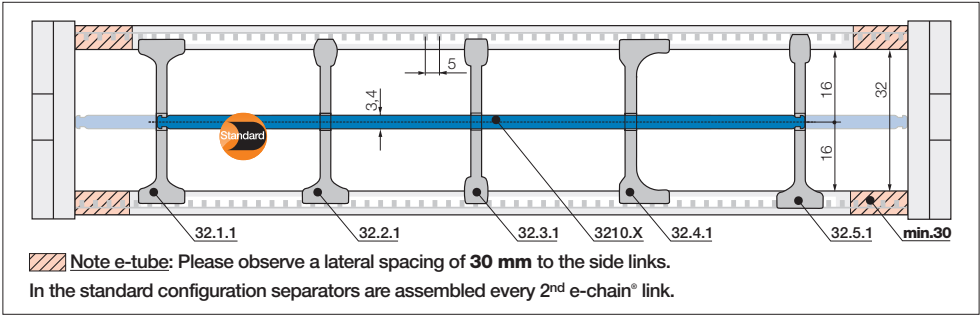

# E4.1 | Series E4.32 | Accessories

Interior separation | New generation - Previous separation options ► [www.igus.eu/eu/E4.32](http://www.igus.eu/eu/E4.32)





**Standard separator, wide base**

unassembled	<b>32.1</b>
assembled	<b>32.1.1</b>

## Standard - for all applications

Separator with a wide base for maximum locking strength and safe standing in e-chains® and e-tubes.



**Separator for QuickLock crossbar**

unassembled	<b>32.2</b>
assembled	<b>32.2.1</b>

## For even faster installation

Separator for igus® QuickLock crossbar 385.X.Q. Firm hold to one side with a wide base, narrow on opposed side for easy cable assembly (slight grip). For e-tubes also.



**Separator, narrow base**

unassembled	<b>32.3</b>
assembled	<b>32.3.1</b>

## For many thin cables

Separator with a narrow base for a large number of thin cables side by side. Saves space in e-chains® and e-tubes. Also available for QuickLock crossbars.



**Separator, asymmetrical**

unassembled	<b>32.4</b>
assembled	<b>32.4.1</b>

## For side-mounted applications

Asymmetrical separator, for defined distance. No additional spacers necessary for e-chains® and e-tubes.



**Notch separator for notch crossbar**

unassembled	<b>32.5</b>
assembled	<b>32.5.1</b>

## Locks safely in 5 mm increments

Notch separator for the new notch crossbar, with scaling on the notch crossbars. For exact positioning in e-chains® and e-tubes. Recommended for side-mounted applications.

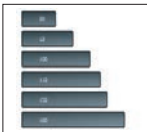

**Full-width shelf, lockable**

unassembled	<b>3200.X</b>
assembled	<b>3210.X</b>

## Horizontal separation

Shelf locks safely into separators on both ends, fixed width possible. Separators can be moved freely over the shelf in horizontal direction. Can be used at one height.

## Lockable full-width shelves



	Width X [mm]		Width X [mm]		Width X [mm]			
	unassembled	assembled	unassembled	assembled	unassembled	assembled		
050	3200.050	3210.050	125	3200.125	3210.125	225	3200.225	3210.225
075	3200.075	3210.075	150	3200.150	3210.150	250	3200.250	3210.250
100	3200.100	3210.100	175	3200.175	3210.175			
115	3200.115	3210.115	200	3200.200	3210.200			

# E4.1 | Series E4.32 | Further Accessories

## Extension links | Extender crossbars

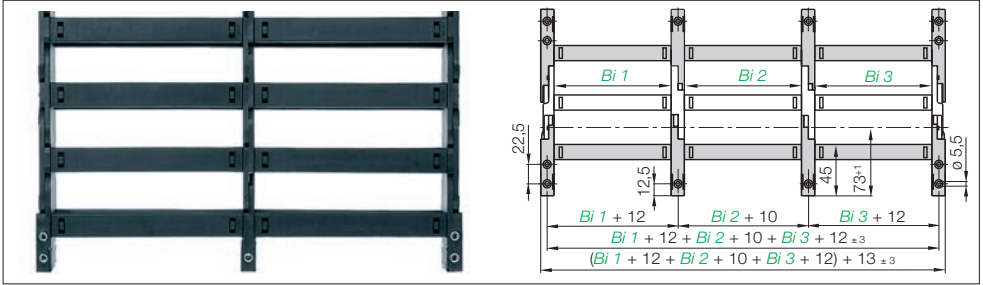

### Extension links | For extremely wide e-chains® up to 3,0 m

- Virtually limitless side-by-side attachment for high fill weights necessitate extremely wide e-chains® (up to 3000 mm)
- The unsupported length  $FL_G$  max. can be increased when additional loads are required

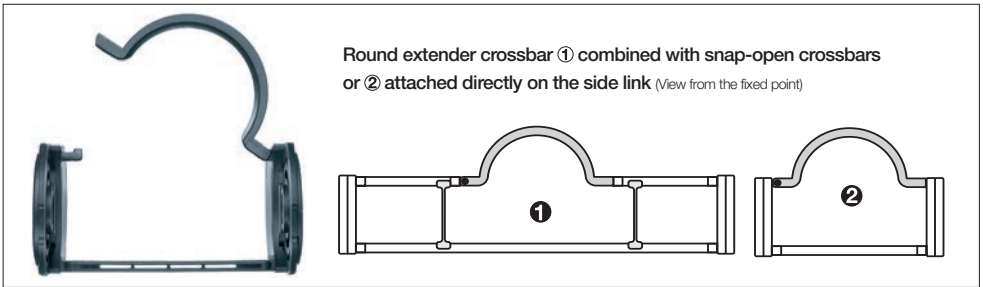

### Extender crossbars | Safe guiding for large hoses

- Suitable for hoses with a maximum outer diameter of 245 mm
- Gliding with crossbars assembled along outer radius and a special guide trough
- Extender crossbar ① for snap-open crossbars or ② attached directly on the side link

Part No. single part	Max Ø [mm] hose	Form	② Installation on side link	① Combination with snap-open crossbars
385.15.RHD115	105	○ round	no	yes
385.18.RD115	105	○ round	yes	no

## E4.1 | Series E4.32 | Further Accessories

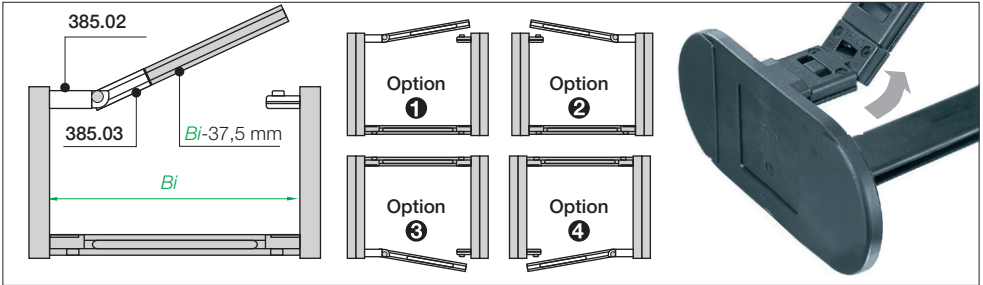

### Hinged crossbars | When snap-open crossbars have to remain attached

- Please consult igus® for design assistance
- Hinged crossbar: Part No. 385.02
- Snap-open crossbar (shortened):  $Bi-37,5$  mm Part No. 385.03 (smallest inner width  $Bi = 87,5$ )

### Optional: Support tray tool kit.

#### For support of the lower run.

Simple one-piece support trays according to your requirements and specification.

The complete range with order options ► from page 714



Many e-chains® are used in this customized CNC-machine for the woodworking industry

# E4.1 | Series E4.42 | Delivery program

Stable due to undercut design, medium inner height



- e-chains® | Series E4.42 crossbars every link (crossbars removable along both radii)
- e-chains® | Series H4.42 crossbars every 2<sup>nd</sup> link (crossbars removable along both radii)
- e-tubes | Series R4.42 fully enclosed (hinged snap-open removable lids along outer radius)

Part No. e-chains® / e-tubes	Bi [mm]	Ba [mm]	E4.42 [kg/m]	H4.42 [kg/m]	R4.42 [kg/m]
E4. H4. R4.1) 42. 05. R.0	50	76	1,923	1,804	2,150
E4. H4. - 42. 06. R.0	68	94	2,031	1,858	-
E4. H4. R4. 42. 07. R.0	75	101	2,059	1,872	2,280
E4. H4. R4. 42. 087.R.0	87	114	2,119	1,903	2,410
E4. H4. - 42. 097.R.0	97	120	2,135	1,919	-
E4. H4. R4. 42. 10. R.0	100	126	2,188	1,973	2,520
E4. H4. R4. 42. 11. R.0	108	134	2,235	1,960	2,570
E4. H4. - 42. 112.R.0	112	139	2,247	1,966	-
E4. H4. R4. 42. 12. R.0	125	151	2,341	2,014	2,730
E4. H4. - 42. 137.R.0	137	164	2,385	2,035	-
E4. H4. R4. 42. 15. R.0	150	176	2,460	2,073	2,980
E4. H4. - 42. 162.R.0	162	189	2,484	2,085	-
E4. H4. R4. 42. 17. R.0	168	194	2,553	2,119	3,150
E4. H4. - 42. 18. R.0	175	201	2,571	2,128	-
E4. H4. - 42. 187.R.0	187	214	2,610	2,148	-
E4. H4. R4. 42. 20. R.0	200	226	2,715	2,200	3,450

Part No. e-chains® / e-tubes	Bi [mm]	Ba [mm]	E4.42 [kg/m]	H4.42 [kg/m]	R4.42 [kg/m]
E4. H4. - 42. 212.R.0	212	239	2,757	2,221	-
E4. H4. - 42. 23. R.0	225	251	2,841	2,263	-
E4. H4. - 42. 237.R.0	237	264	2,865	2,275	-
E4. H4. R4. 42. 25. R.0	250	276	2,979	2,332	4,250
E4. H4. - 42. 262.R.0	262	289	3,048	2,367	-
E4. H4. - 42. 28. R.0	275	301	3,108	2,397	-
E4. H4. - 42. 29. R.0	287	314	3,136	2,411	-
E4. H4. R4. 42. 30. R.0	300	326	3,243	2,464	4,890
E4. H4. - 42. 312.R.0	312	339	3,262	2,474	-
E4. H4. - 42. 325.R.0	325	351	3,348	2,517	-
E4. H4. - 42. 337.R.0	337	364	3,399	2,542	-
E4. H4. - 42. 350.R.0	350	376	3,588	2,637	-
E4. H4. - 42. 362.R.0	362	389	3,669	2,677	-
E4. H4. - 42. 375.R.0	375	402	3,730	2,708	-
E4. H4. - 42. 387.R.0	387	414	3,786	2,736	-
E4. H4. - 42. 400.R.0	400	426	3,840	2,763	-

\*Radius not available for e-tubes 1) Removable lid only, no hinged option

Available bending radii *R* [mm] 075\* | 100\* | 115\* | 125 | 150 | 160 | 175 | 200 | 250 | 300 | 350

Supplement Part No. with required radius (*R*). Examples:

E4.42.30.300.0 = e-chain® with crossbars every link, inner width *Bi* 300 mm, radius *R* 300 mm, color black

H4.42.30.300.0 = e-chain® with crossbars every 2<sup>nd</sup> link, inner width *Bi* 300 mm, radius *R* 300 mm, color black

R4.42.30.300.0 = e-tube fully enclosed, inner width *Bi* 300 mm, radius *R* 300 mm, color black



ESD/ATEX permanently conductive e-chains® - E4.42 several widths with delivery from stock: Inner widths *Bi* 50 - 200, radii *R* 75 - 250. Full ESD delivery program ► [www.igus.eu/eu/ESD](http://www.igus.eu/eu/ESD)



## Unsupported applications | Short travels

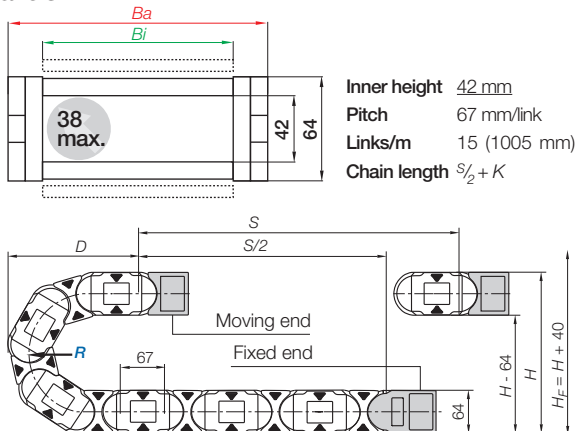
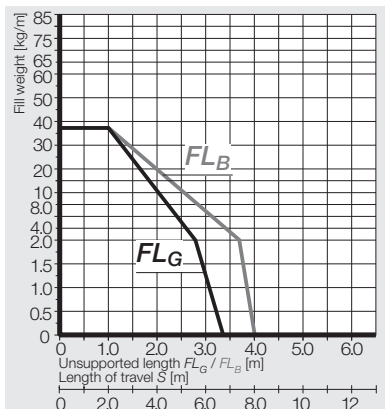

	075*	100*	115*	125	150	160	175	200	250	300	350
$H_{+25}^0$	214	264	294	314	364	384	414	464	564	664	764
$D$	208	233	248	258	283	293	308	333	383	433	483
$K$	370	450	500	530	610	640	685	765	920	1080	1235

The required clearance height:  $H_F = H + 40$  mm (with 3,0 kg/m fill weight)

\*Radius not available for e-tubes

## Gliding applications | Long travels from 12 m to max. 300 m

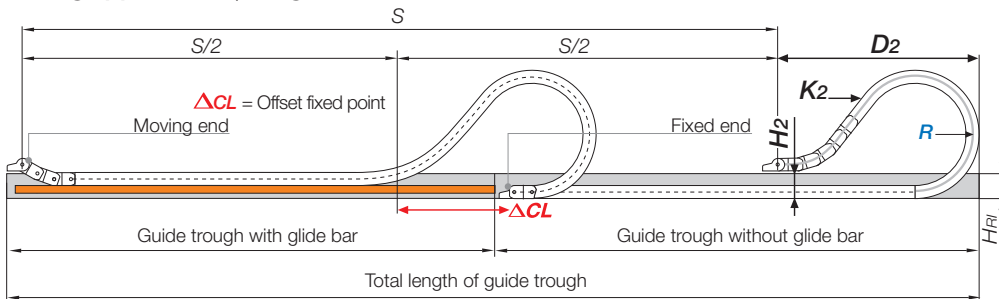

**Note:** For long travel applications with more than 100 m we recommend to realize the engineering of such a plant by our technicians. In case of travels between 8 and 12 m we recommend a longer unsupported length. **Chain length**  $S/2 + K_2$

	075*	100*	115*	125	150	160	175	200	250	300	350
$H_2$	150	200	230	186	186	186	186	186	186	186	186
$D_2^{+25}$	174	199	**	475	570	623	670	780	1030	1150	1500
$K_2$	370	450	**	804	938	1072	1139	1340	1675	1943	2412
$\Delta CL$	-	-	-	230	300	380	380	460	660	730	1030

\*Radius not available for e-tubes \*\*Values upon request

# E4.1 | Series E4.42 | Accessories

KMA mounting brackets | Attachment on all sides | pivoting | locking

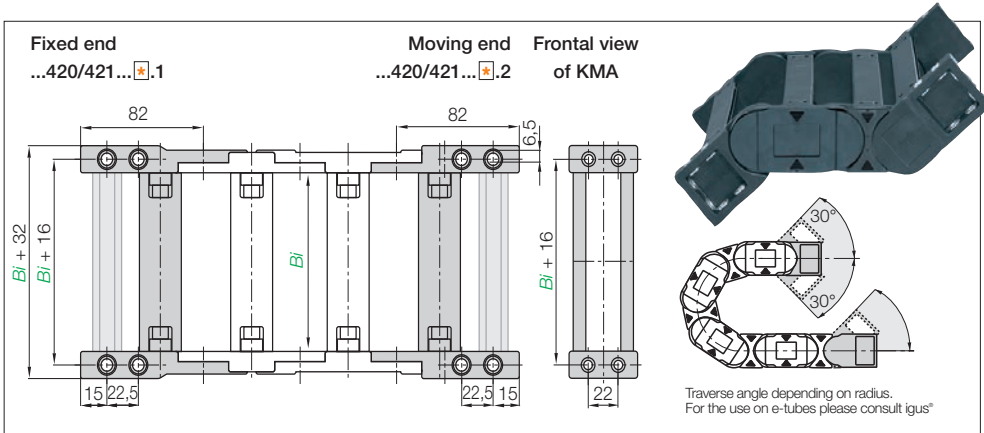

**KMA pivoting** | Standard | Recommended for unsupported and gliding applications  
**KMA locking** | Recommended for vertical hanging and standing applications

Width Index	Standard	Part No. full set KMA pivoting:	Part No. full set KMA locking:	Bi [mm]	Width Index	Standard	Part No. full set KMA pivoting:	Part No. full set KMA locking:	Bi [mm]
05.	▶	E4. R4. 420.05 .12.C	E4. R4. 421.05 .12.C	50	212.	▶	E4. - 420.212 .12.C	E4. - 421.212 .12.C	212
06.	▶	E4. - 420.06 .12.C	E4. - 421.06 .12.C	68	23.	▶	E4. - 420.23 .12.C	E4. - 421.23 .12.C	225
07.	▶	E4. R4. 420.07 .12.C	E4. R4. 421.07 .12.C	75	237.	▶	E4. - 420.237 .12.C	E4. - 421.237 .12.C	237
087.	▶	E4. R4. 420.087 .12.C	E4. R4. 421.087 .12.C	87	25.	▶	E4. R4. 420.25 .12.C	E4. R4. 421.25 .12.C	250
09.	▶	E4. - 420.09 .12.C	E4. - 421.09 .12.C	97	262.	▶	E4. - 420.262 .12.C	E4. - 421.262 .12.C	262
10.	▶	E4. R4. 420.10 .12.C	E4. R4. 421.10 .12.C	100	28.	▶	E4. - 420.28 .12.C	E4. - 421.28 .12.C	275
11.	▶	E4. R4. 420.11 .12.C	E4. R4. 421.11 .12.C	108	29.	▶	E4. - 420.29 .12.C	E4. - 421.29 .12.C	287
112.	▶	E4. - 420.112 .12.C	E4. - 421.112 .12.C	112	30.	▶	E4. R4. 420.30 .12.C	E4. R4. 421.30 .12.C	300
12.	▶	E4. R4. 420.12 .12.C	E4. R4. 421.12 .12.C	125	312.	▶	E4. - 420.312 .12.C	E4. - 421.312 .12.C	312
137.	▶	E4. - 420.137 .12.C	E4. - 421.137 .12.C	137	325.	▶	E4. - 420.325 .12.C	E4. - 421.325 .12.C	325
15.	▶	E4. R4. 420.15 .12.C	E4. R4. 421.15 .12.C	150	337.	▶	E4. - 420.337 .12.C	E4. - 421.337 .12.C	337
162.	▶	E4. - 420.162 .12.C	E4. - 421.162 .12.C	162	350.	▶	E4. - 420.350 .12.C	E4. - 421.350 .12.C	350
17.	▶	E4. R4. 420.17 .12.C	E4. R4. 421.17 .12.C	175	362.	▶	E4. - 420.362 .12.C	E4. - 421.362 .12.C	362
18.	▶	E4. - 420.18 .12.C	E4. - 421.18 .12.C	168	375.	▶	E4. - 420.375 .12.C	E4. - 421.375 .12.C	375
187.	▶	E4. - 420.187 .12.C	E4. - 421.187 .12.C	187	387.	▶	E4. - 420.387 .12.C	E4. - 421.387 .12.C	387
20.	▶	E4. R4. 420.20 .12.C	E4. R4. 421.20 .12.C	200	400.	▶	E4. - 420.400 .12.C	E4. - 421.400 .12.C	400

**Note\***: The E4.1 may end with either an inner or an outer side link. An outer side link always forms the first e-chain® link at the moving end. The Part No. depend on an even or odd numbers of links. Please insert: Index **1** (for odd) or **2** (for even). For the **preassembled** mode please add index **A**.

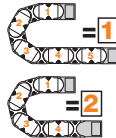

E4.420.30.2.12.CA	Part No. structure
	A... must be indicated on preassembled configurations
	C-profile option
	Full set
	Even numbers of links
	Width index
	Series



**Strain relief** e.g. clamps, tiewrap plates, nuggets and plug-in clips are available from stock. The complete chainfix range with order options ▶ from page 630

# E4.1 | Series E4.42 | Accessories

Interior separation | New generation - Previous separation options ► [www.igus.eu/eu/E4.42](http://www.igus.eu/eu/E4.42)

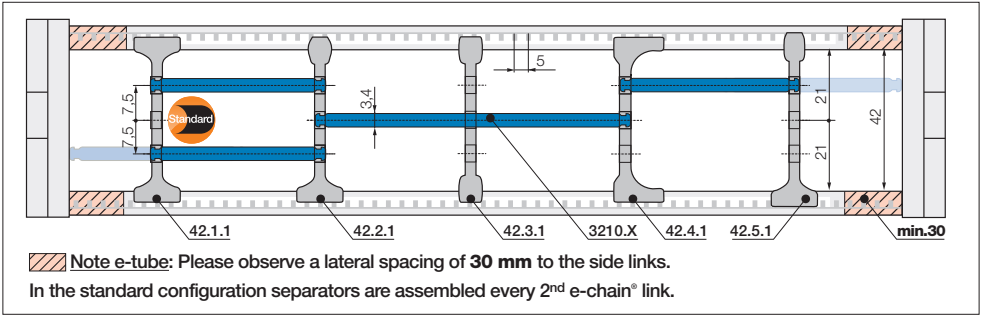

**Standard separator, wide base**  
unassembled **42.1**  
assembled **42.1.1**

## Standard - for all applications

Separator with a wide base for maximum locking strength and safe standing in e-chains® and e-tubes.

**Separator for QuickLock crossbar**  
unassembled **42.2**  
assembled **42.2.1**

## For even faster installation

Separator for igus® QuickLock crossbar 385.X.Q. Firm hold to one side with a wide base, narrow on opposed side for easy cable assembly (slight grip). For e-tubes also.

**Separator, narrow base**  
unassembled **42.3**  
assembled **42.3.1**

## For many thin cables

Separator with a narrow base for a large number of thin cables side by side. Saves space in e-chains® and e-tubes. Also available for QuickLock crossbars.

**Separator, asymmetrical**  
unassembled **42.4**  
assembled **42.4.1**

## For side-mounted applications

Asymmetrical separator, for defined distance. No additional spacers necessary for e-chains® and e-tubes.

**Notch separator for notch crossbar**  
unassembled **42.5**  
assembled **42.5.1**

## Locks safely in 5 mm increments

Notch separator for the new notch crossbar, with scaling on the notch crossbars. For exact positioning in e-chains® and e-tubes. Recommended for side-mounted applications.

**Full-width shelf, lockable**  
unassembled **3200.X**  
assembled **3210.X**

## Horizontal separation

Shelf locks safely into separators on both ends, fixed width possible. Separators can be moved freely over the shelf in horizontal direction. Can be arranged at 3 different heights.

## Lockable full-width shelves



	Width X [mm]	unassembled	assembled	Width X [mm]	unassembled	assembled	Width X [mm]	unassembled	assembled
	050	3200.050	3210.050	125	3200.125	3210.125	225	3200.225	3210.225
	075	3200.075	3210.075	150	3200.150	3210.150	250	3200.250	3210.250
	100	3200.100	3210.100	175	3200.175	3210.175			
	115	3200.115	3210.115	200	3200.200	3210.200			

# E4.1 | Series E4.42 | Further Accessories

## Extension links | Extender crossbars

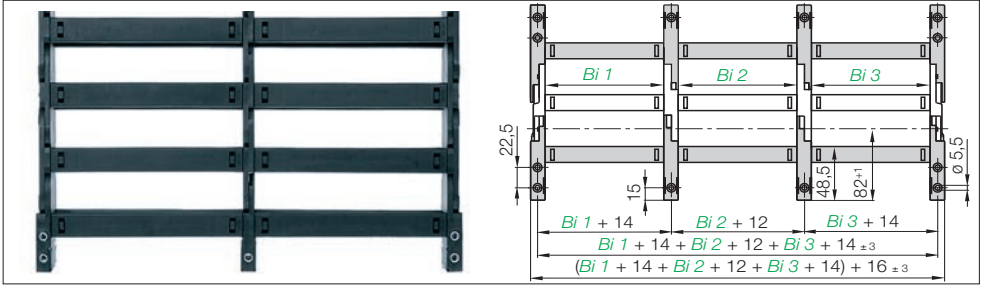

### Extension links | For extremely wide e-chains® up to 3,0 m

- Virtually limitless side-by-side attachment for high fill weights necessitate extremely wide e-chains® (up to 3000 mm)
- The unsupported length  $FL_G$  max. can be increased when additional loads are required

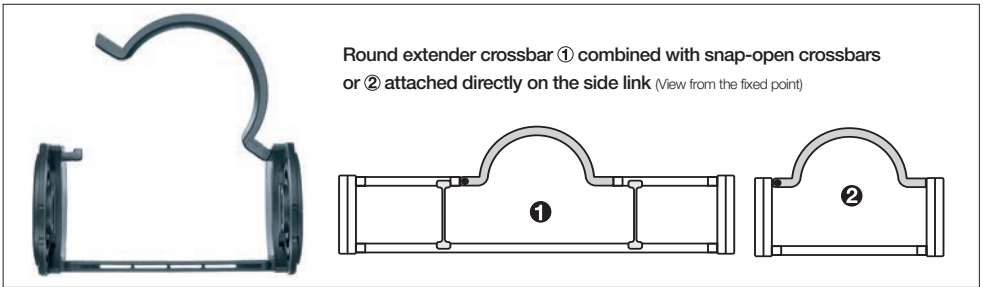

### Extender crossbars | Safe guiding for large hoses

- Suitable for hoses with a maximum outer diameter of 245 mm
- Gliding with crossbars assembled along outer radius and a special guide trough
- Extender crossbar ① for snap-open crossbars or ② attached directly on the side link

Part No. single part	Max Ø [mm] hose	Form	② Installation on side link	① Combination with snap-open crossbars
385.15.RHD115	105	○ round	no	yes
385.18.RD115	105	○ round	yes	no



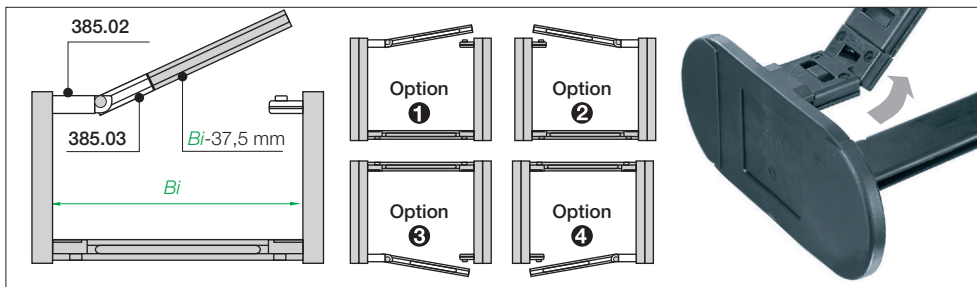

**Hinged crossbars | When snap-open crossbars have to remain attached**

- Please consult igus® for design assistance
- Hinged crossbar: Part No. 385.02
- Snap-open crossbar (shortened): *Bi*-37,5 mm Part No. 385.03 (smallest inner width *Bi* = 87,5)

**Optional: Support tray tool kit.**

**For support of the lower run.**

Simple one-piece support trays according to your requirements and specification.

The complete range with order options ► from page 714



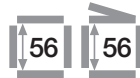

e-chains® | Series E4.56 crossbars every link (crossbars removable along both radii)

e-chains® | Series H4.56 crossbars every 2<sup>nd</sup> link (crossbars removable along both radii)

e-tubes | Series R4.56 fully enclosed (hinged snap-open removable lids along outer radius)

Part No. e-chains® / e-tubes	<i>Bi</i> [mm]	<i>Ba</i> [mm]	E4.56 [kg/m]	H4.56 [kg/m]	R4.56 [kg/m]
E4. H4. - 56. 05. R.0	50	84	3,301	3,158	-
E4. H4. - 56. 06. R.0	65	99	3,390	3,202	-
E4. H4. R4. 1) 56. 07. R.0	75	109	3,458	3,236	3,910
E4. H4. - 56. 08. R.0	87	121	3,538	3,276	-
E4. H4. R4. 56. 10. R.0	100	134	3,633	3,323	4,200
E4. H4. - 56. 11. R.0	112	147	3,749	3,382	-
E4. H4. R4. 56. 12. R.0	125	159	3,827	3,420	4,560
E4. H4. - 56. 13. R.0	137	172	3,963	3,488	-
E4. H4. R4. 56. 15. R.0	150	184	4,000	3,507	4,940
E4. H4. - 56. 16. R.0	162	197	4,113	3,563	-
E4. H4. R4. 56. 17. R.0	175	209	4,245	3,630	5,250
E4. H4. - 56. 18. R.0	187	222	4,357	3,685	-
E4. H4. R4. 56. 20. R.0	200	234	4,413	3,713	5,560
E4. H4. - 56. 21. R.0	212	247	4,484	3,749	-
E4. H4. - 56. 22. R.0	225	259	4,553	3,784	-
E4. H4. - 56. 23. R.0	237	272	4,663	3,838	-
E4. H4. R4. 56. 25. R.0	250	284	4,774	3,894	6,290
E4. H4. - 56. 26. R.0	262	297	4,865	3,939	-
E4. H4. R4. 56. 27. R.0	275	309	4,967	3,990	6,650
E4. H4. - 56. 28. R.0	287	322	5,025	4,019	-
E4. H4. R4. 56. 30. R.0	300	334	5,177	4,095	6,950

Part No. e-chains® / e-tubes	<i>Bi</i> [mm]	<i>Ba</i> [mm]	E4.56 [kg/m]	H4.56 [kg/m]	R4.56 [kg/m]
E4. H4. - 56. 31. R.0	312	347	5,214	4,114	-
E4. H4. - 56. 32. R.0	325	359	5,317	4,166	-
E4. H4. - 56. 33. R.0	337	372	5,437	4,225	-
E4. H4. R4. 56. 35. R.0	350	384	5,639	4,326	7,650
E4. H4. - 56. 36. R.0	362	397	5,549	4,282	-
E4. H4. - 56. 37. R.0	375	409	5,646	4,330	-
E4. H4. - 56. 38. R.0	387	422	5,762	4,388	-
E4. H4. R4. 56. 40. R.0	400	434	6,031	4,523	8,650
E4. H4. - 56. 41. R.0	412	447	5,955	4,484	-
E4. H4. - 56. 42. R.0	425	459	6,247	4,630	-
E4. H4. - 56. 43. R.0	437	472	6,090	4,552	-
E4. H4. - 56. 45. R.0	450	484	6,420	4,717	-
E4. H4. R4. 56. 46. R.0	462	497	6,372	4,693	9,118
E4. H4. - 56. 47. R.0	475	509	6,412	4,713	-
E4. H4. - 56. 48. R.0	487	522	6,658	4,836	-
E4. H4. - 56. 50. R.0	500	534	6,755	4,885	-
E4. H4. - 56. 51. R.0	512	547	6,688	4,841	-
E4. H4. - 56. 52. R.0	525	559	6,842	4,928	-
E4. H4. - 56. 53. R.0	537	572	6,934	4,974	-
E4. H4. - 56. 55. R.0	550	584	7,355	5,184	-
E4. H4. - 56. 60. R.0	600	634	7,584	5,299	-

\*Radius not available for e-tubes 1) Removable lid only, no hinged option

Available bending radii *R* [mm] 135\* | 150 | 175 | 200 | 240 | 250 | 300 | 350 | 400 | 450 | 500

Supplement Part No. with required radius (*R*). Examples:

E4.56.30.300.0 = e-chain® with crossbars every link, inner width *Bi* 300 mm, radius *R* 300 mm, color black

H4.56.30.300.0 = e-chain® with crossbars every 2<sup>nd</sup> link, inner width *Bi* 300 mm, radius *R* 300 mm, color black

R4.56.30.300.0 = e-tube fully enclosed, inner width *Bi* 300 mm, radius *R* 300 mm, color black



ESD/ATEX permanently conductive e-chains® - E4.56 several widths with delivery from stock: Inner widths *Bi* 75 - 300, radii *R* 135 - 250. Full ESD delivery program ► [www.igus.eu/eu/ESD](http://www.igus.eu/eu/ESD)



## Unsupported applications | Short travels

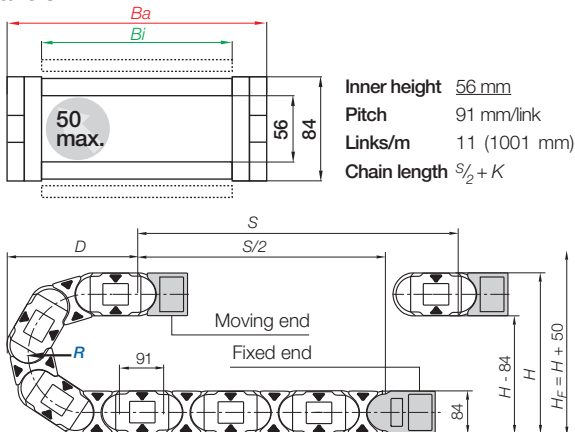
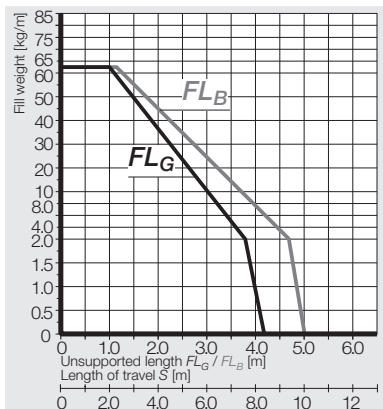

$R$	135	150	175	200	240	250	300	350	400	450	500
$H_{+25}^0$	354	384	434	484	564	584	684	784	884	984	1084
$D$	314	329	354	379	419	429	479	529	579	629	679
$K$	610	655	735	815	940	970	1125	1285	1440	1600	1755

The required clearance height:  $H_F = H + 50$  mm (with 3,0 kg/m fill weight)

\*Radius not available for e-tubes

## Gliding applications | Long travels from 12 m to max. 400 m

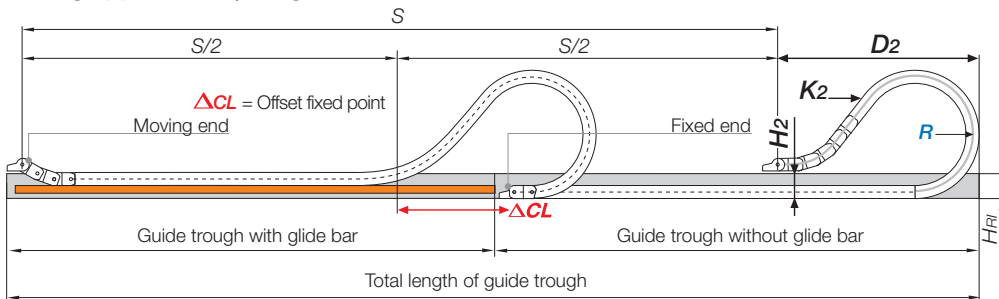

**Note:** For for long travel applications with more than 100 m we recommend to realize the engineering of such a plant by our technicians. In case of travels between 10 and 12 m we recommend a longer unsupported length. **Chain length**  $\frac{S}{2} + K_2$

$R$	135*	150	175	200	240	250	300	350	400	450	500
$H_2$	270	266	266	266	266	266	266	266	266	266	266
$D_{+25}_2$	268	450	580	710	900	980	1180	1440	1530	1700	1850
$K_2$	610	819	1092	1274	1547	1638	2002	2275	2548	2912	3276
$\Delta CL$	-	159	259	359	509	559	709	909	959	1059	1159

\*Radius not available for e-tubes

# E4.1 | Series E4.56 | Accessories

KMA mounting brackets | Attachment on all sides | pivoting | locking

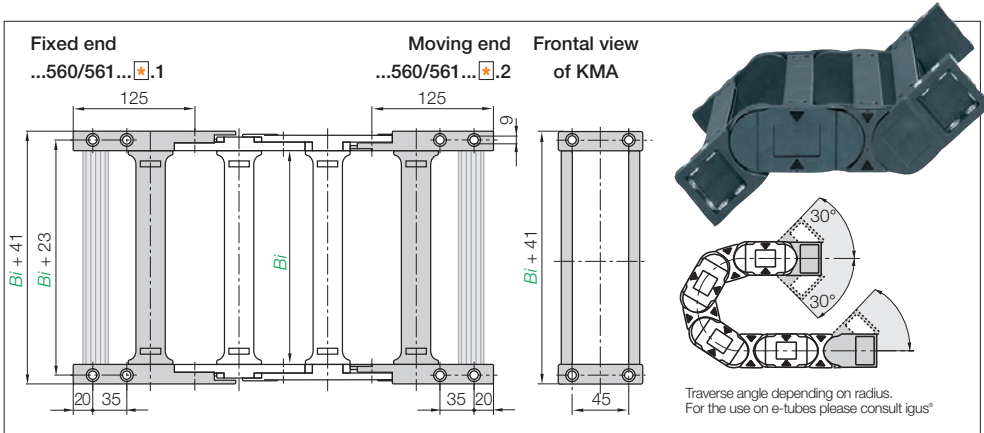

**KMA pivoting** | Standard | Recommended for unsupported and gliding applications  
**KMA locking** | Recommended for vertical hanging and standing applications

Width Index	Standard	Part No. full set KMA pivoting:	Part No. full set KMA locking:	Bi [mm]	Width Index	Standard	Part No. full set KMA pivoting:	Part No. full set KMA locking:	Bi [mm]
05.	▶	E4. - 560.05.12.C	E4. - 561.05.12.C	50	31.	▶	E4. - 560.31.12.C	E4. - 561.31.12.C	312
06.	▶	E4. - 560.06.12.C	E4. - 561.06.12.C	65	32.	▶	E4. - 560.32.12.C	E4. - 561.32.12.C	325
07.	▶	E4. R4.560.07.12.C	E4. R4.561.07.12.C	75	33.	▶	E4. - 560.33.12.C	E4. - 561.33.12.C	337
08.	▶	E4. - 560.08.12.C	E4. - 561.08.12.C	87	35.	▶	E4. R4.560.35.12.C	E4. R4.561.35.12.C	350
10.	▶	E4. R4.560.10.12.C	E4. R4.561.10.12.C	100	36.	▶	E4. - 560.36.12.C	E4. - 561.36.12.C	362
11.	▶	E4. - 560.11.12.C	E4. - 561.11.12.C	112	37.	▶	E4. - 560.37.12.C	E4. - 561.37.12.C	375
12.	▶	E4. R4.560.12.12.C	E4. R4.561.12.12.C	125	38.	▶	E4. - 560.38.12.C	E4. - 561.38.12.C	387
13.	▶	E4. - 560.13.12.C	E4. - 561.13.12.C	137	40.	▶	E4. R4.560.40.12.C	E4. R4.561.40.12.C	400
15.	▶	E4. R4.560.15.12.C	E4. R4.561.15.12.C	150	41.	▶	E4. - 560.41.12.C	E4. - 561.41.12.C	412
16.	▶	E4. - 560.16.12.C	E4. - 561.16.12.C	162	42.	▶	E4. - 560.42.12.C	E4. - 561.42.12.C	425
17.	▶	E4. R4.560.17.12.C	E4. R4.561.17.12.C	175	43.	▶	E4. - 560.43.12.C	E4. - 561.43.12.C	437
18.	▶	E4. - 560.18.12.C	E4. - 561.18.12.C	187	45.	▶	E4. - 560.45.12.C	E4. - 561.45.12.C	450
20.	▶	E4. R4.560.20.12.C	E4. R4.561.20.12.C	200	46.	▶	E4. R4.560.46.12.C	E4. R4.561.46.12.C	462
21.	▶	E4. - 560.21.12.C	E4. - 561.21.12.C	212	47.	▶	E4. - 560.47.12.C	E4. - 561.47.12.C	475
22.	▶	E4. - 560.22.12.C	E4. - 561.22.12.C	225	48.	▶	E4. - 560.48.12.C	E4. - 561.48.12.C	487
23.	▶	E4. - 560.23.12.C	E4. - 561.23.12.C	237	50.	▶	E4. - 560.50.12.C	E4. - 561.50.12.C	500
25.	▶	E4. R4.560.25.12.C	E4. R4.561.25.12.C	250	51.	▶	E4. - 560.51.12.C	E4. - 561.51.12.C	512
26.	▶	E4. - 560.26.12.C	E4. - 561.26.12.C	262	52.	▶	E4. - 560.52.12.C	E4. - 561.52.12.C	525
27.	▶	E4. R4.560.27.12.C	E4. R4.561.27.12.C	275	53.	▶	E4. - 560.53.12.C	E4. - 561.53.12.C	537
28.	▶	E4. - 560.28.12.C	E4. - 561.28.12.C	287	55.	▶	E4. - 560.55.12.C	E4. - 561.55.12.C	550
30.	▶	E4. R4.560.30.12.C	E4. R4.561.30.12.C	300	60.	▶	E4. - 560.60.12.C	E4. - 561.60.12.C	600

**Note\***: The E4.1 may end with either an inner or an outer side link. An outer side link always forms the first e-chain® link at the moving end. The Part No. depend on an even or odd numbers of links. Please insert: Index 1 (for odd) or 2 (for even). For the **preassembled** mode please add index **A**.

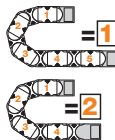

**E4.560.30.2.12.CA** Part No. structure

- A... must be indicated on preassembled configurations
- C-profile option
- Full set
- Even numbers of links
- Width index
- Series



# E4.1 | Series E4.56 | Accessories

Interior separation | New generation - Previous separation options ► [www.igus.eu/eu/E4.56](http://www.igus.eu/eu/E4.56)

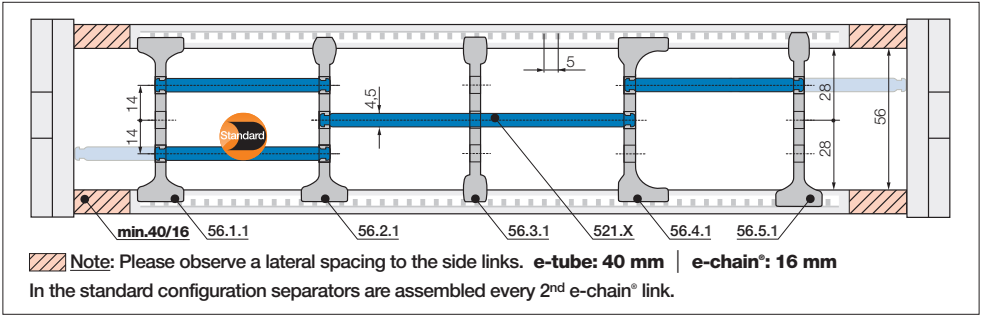

		<b>Standard separator, wide base</b>
		unassembled <b>56.1</b> assembled <b>56.1.1</b>

### Standard - for all applications

Separator with a wide base for maximum locking strength and safe standing in e-chains\* and e-tubes.

		<b>Separator for QuickLock crossbar</b>
		unassembled <b>56.2</b> assembled <b>56.2.1</b>

### For even faster installation

Separator for igus® QuickLock crossbar 450.X.Q. Firm hold to one side with a wide base, narrow on opposed side for easy cable assembly (slight grip). For e-tubes also.

		<b>Separator, narrow base</b>
		unassembled <b>56.3</b> assembled <b>56.3.1</b>

### For many thin cables

Separator with a narrow base for a large number of thin cables side by side. Saves space in e-chains\* and e-tubes. Also available for QuickLock crossbars.

		<b>Separator, asymmetrical</b>
		unassembled <b>56.4</b> assembled <b>56.4.1</b>

### For side-mounted applications

Asymmetrical separator, for defined distance. No additional spacers necessary for e-chains\* and e-tubes.

		<b>Notch separator for notch crossbar</b>
		unassembled <b>56.5</b> assembled <b>56.5.1</b>

### Locks safely in 5 mm increments

Notch separator for the new notch crossbar, with scaling on the notch crossbars. For exact positioning in e-chains\* and e-tubes. Recommended for side-mounted applications.

		<b>Full-width shelf, lockable</b>
		unassembled <b>520.X</b> assembled <b>521.X</b>

### Horizontal separation

Shelf locks safely into separators on both ends, fixed width possible. Separators can be moved freely over the shelf in horizontal direction. Can be arranged at 3 different heights.

### Lockable full-width shelves

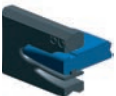

Width X [mm]	unassembled	assembled	Width X [mm]	unassembled	assembled	Width X [mm]	unassembled	assembled
050	520.050	521.050	125	520.125	521.125	225	520.225	521.225
065	520.065	521.065	150	520.150	521.150	250	520.250	521.250
075	520.075	521.075	175	520.175	521.175	300	520.300	521.300
100	520.100	521.100	200	520.200	521.200	450	520.450	521.450

# E4.1 | Series E4.56 | Further Accessories

## Extension links | Extender crossbars

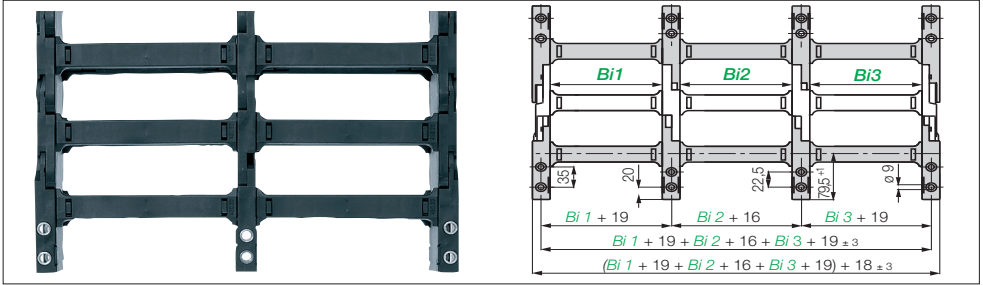

### Extension links | For extremely wide e-chains® up to 3,0 m

- Virtually limitless side-by-side attachment for high fill weights necessitate extremely wide e-chains® (up to 3000 mm)
- The unsupported length  $FL_G$  max. can be increased when additional loads are required

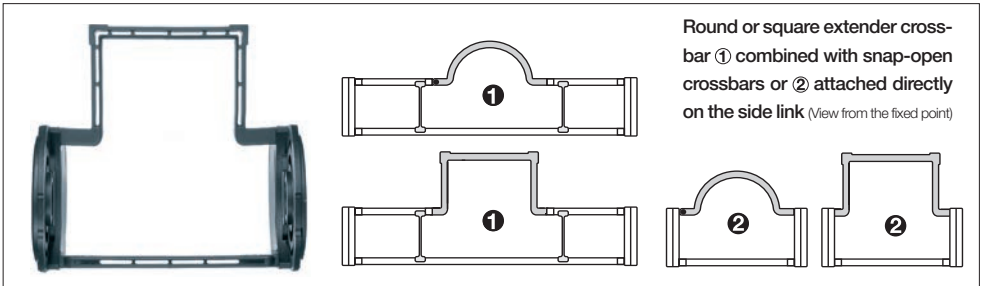

### Extender crossbars | Safe guiding for large hoses

- Suitable for hoses with a maximum outer diameter of 245 mm
- Gliding with crossbars assembled along outer radius and a special guide trough
- Extender crossbar 1 for snap-open crossbars or 2 attached directly on the side link

Part No. single part	Max Ø [mm] hose	Form	② Installation on side link	① Combination with snap-open crossbars
450.15.RHD115	115	○ round	no	yes
450.17.RD115	115	○ round	yes	no
450.25.D150	150	□ square	yes	no
450.30.D200	180	□ square	yes	no
450.35.D250	195	□ square	yes	no
450.40.D300	245	□ square	yes	no
450.20.HD150	150	□ square	no	yes
450.25.HD200	180	□ square	no	yes
450.30.HD250	195	□ square	no	yes

### E4 snapclip - clip-on cable binder

- For side-mounted applications
- Serves as a clip-on, lateral guide for hoses and cables on e-chains®
- The loops can be adjusted as required
- Compatible with many E4 e-chains®
- One clip and one locking band are needed for each e-chain® link. The complete range with order options ► [www.igus.eu/eu/E4.56](http://www.igus.eu/eu/E4.56)

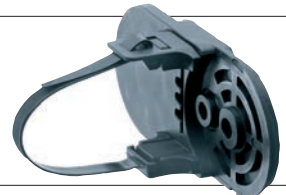

## The igus® e-chain® opener reduces assembly time

e-chain® opener tools for convenient opening and closing of E4 series igus® e-chains® ● Especially for e-chains® with many crossbars the assembly is much easier ● Especially in areas difficult to access mounting is simplified big savings in assembly time. Please call us or visit ► [www.igus.eu/eu/E4savetime](http://www.igus.eu/eu/E4savetime)

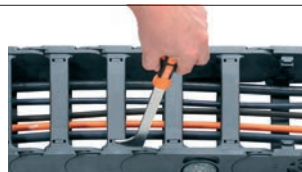

## Optional: Support tray tool kit.

### For support of the lower run.

Simple one-piece support trays according to your requirements and specification. The complete range with order options ► from page 714



## Heavy-Duty Version - For very long travels or high additional loads - Series 4040HD-R8840HD

● High side-mount stability due to undercut ● High torsional rigidity and tensile stability ● Robust Steel-Mounting Brackets ● For long-term operation in very humid environments. Please call us or visit ► [www.igus.eu/eu/4040HD](http://www.igus.eu/eu/4040HD)



igus® System E4 e-chains® in a container-crane. High loads and high speeds also at difficult weather conditions

# E4.1 | Series E4.80 | Delivery program

Stable due to undercut design, very large inner height



**e-chains® | Series E4.80 crossbars every link** (crossbars removable along both radii)

**e-chains® | Series H4.80 crossbars every 2<sup>nd</sup> link** (crossbars removable along both radii)

**e-tubes | Series R4.80 fully enclosed** (hinged snap-open removable lids along outer radius)

Part No. e-chains® / e-tubes	<i>Bi</i> [mm]	<i>Ba</i> [mm]	E4.80 [kg/m]	H4.80 [kg/m]	R4.80 [kg/m]
E4. H4. – 80.05. R.0	50	100	5,339	5,221	–
E4. H4. – 80.06. R.0	65	115	5,411	5,257	–
E4. H4. – 80.07. R.0	75	125	5,467	5,285	–
E4. H4. – 80.08. R.0	87	137	5,563	5,319	–
E4. H4. – 80.10. R.0	100	150	5,610	5,357	–
E4. H4. – 80.11. R.0	112	163	5,705	5,404	–
E4. H4. – 80.12. R.0	125	175	5,769	5,436	–
E4. H4. – 80.13. R.0	137	188	5,890	5,492	–
E4. H4. R4.1) 80.15. R.0	150	200	5,911	5,507	6,720
E4. H4. – 80.16. R.0	162	213	6,003	5,553	–
E4. H4. – 80.17. R.0	175	225	6,111	5,607	–
E4. H4. – 80.18. R.0	187	238	6,202	5,653	–
E4. H4. R4. 80.20. R.0	200	250	6,248	5,676	7,230
E4. H4. – 80.21. R.0	212	263	6,306	5,705	–
E4. H4. – 80.22. R.0	225	275	6,363	5,733	–
E4. H4. – 80.23. R.0	237	288	6,453	5,778	–
E4. H4. R4. 80.25. R.0	250	300	6,543	5,824	8,060
E4. H4. – 80.26. R.0	262	313	6,618	5,861	–
E4. H4. – 80.27. R.0	275	325	6,701	5,902	–
E4. H4. – 80.28. R.0	287	338	6,749	5,926	–
E4. H4. R4. 80.30. R.0	300	350	6,873	5,988	8,730

Part No. e-chains® / e-tubes	<i>Bi</i> [mm]	<i>Ba</i> [mm]	E4.80 [kg/m]	H4.80 [kg/m]	R4.80 [kg/m]
E4. H4. – 80.31. R.0	312	363	6,904	6,004	–
E4. H4. – 80.32. R.0	325	375	6,988	6,046	–
E4. H4. – 80.33. R.0	337	388	7,086	6,095	–
E4. H4. R4. 80.35. R.0	350	400	7,251	6,177	9,470
E4. H4. – 80.36. R.0	362	413	7,178	6,141	–
E4. H4. – 80.37. R.0	375	425	7,257	6,180	–
E4. H4. – 80.38. R.0	387	438	7,352	6,228	–
E4. H4. R4. 80.40. R.0	400	450	7,572	6,338	10,210
E4. H4. – 80.41. R.0	412	463	7,510	6,307	–
E4. H4. – 80.42. R.0	425	475	7,749	6,426	–
E4. H4. – 80.43. R.0	437	488	7,621	6,362	–
E4. H4. – 80.45. R.0	450	500	7,890	6,497	–
E4. H4. R4. 80.46. R.0	462	513	7,851	6,477	10,960
E4. H4. – 80.47. R.0	475	525	7,884	6,494	–
E4. H4. – 80.48. R.0	487	538	8,086	6,595	–
E4. H4. – 80.50. R.0	500	550	8,093	6,598	–
E4. H4. – 80.51. R.0	512	563	8,165	6,634	–
E4. H4. – 80.52. R.0	525	575	8,235	6,670	–
E4. H4. – 80.53. R.0	537	588	8,311	6,707	–
E4. H4. – 80.55. R.0	550	600	8,655	6,879	–
E4. H4. – 80.60. R.0	600	650	8,843	6,973	–

\*Radius not available for e-tubes 1) Removable lid only, no hinged option

Available bending radii *R* [mm] 150\* | 200 | 250 | 300 | 350 | 400 | 500 | 550 | 600 | 1000

Supplement Part No. with required radius (*R*). Examples:

E4.80.30.300.0 = e-chain® with crossbars every link, inner width *Bi* 300 mm, radius *R* 300 mm, color black

H4.80.30.300.0 = e-chain® with crossbars every 2<sup>nd</sup> link, inner width *Bi* 300 mm, radius *R* 300 mm, color black

R4.80.30.300.0 = e-tube fully enclosed, inner width *Bi* 300 mm, radius *R* 300 mm, color black



ESD/ATEX permanently conductive e-chains® - E4.80 several widths with delivery from stock:  
Inner widths *Bi* 75 - 300, radii *R* 200 - 300. Full ESD delivery program ► [www.igus.eu/eu/ESD](http://www.igus.eu/eu/ESD)





## Unsupported applications | Short travels

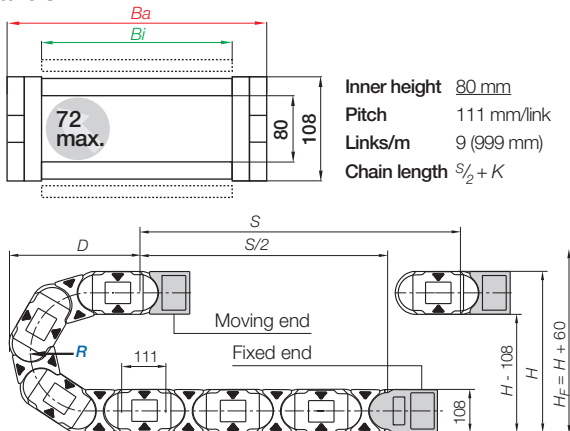
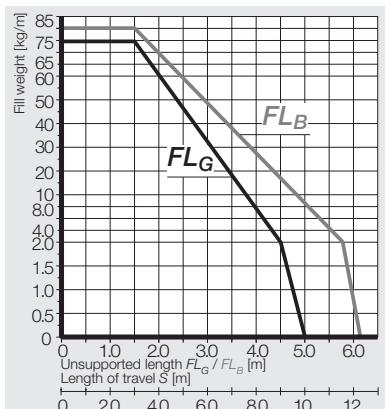

R	150	200	250	300	350	400	500	550	600	1000
$H_{+25}^0$	408	508	608	708	808	908	1108	1208	1308	2108
D	371	421	471	521	571	621	721	771	821	1221
K	695	855	1010	1165	1325	1480	1795	1950	2110	3365

The required clearance height:  $H_F = H + 60$  mm (with 3,0 kg/m fill weight)

\*Radius not available for e-tubes

## Gliding applications | Long travels from 12 m to max. 400 m

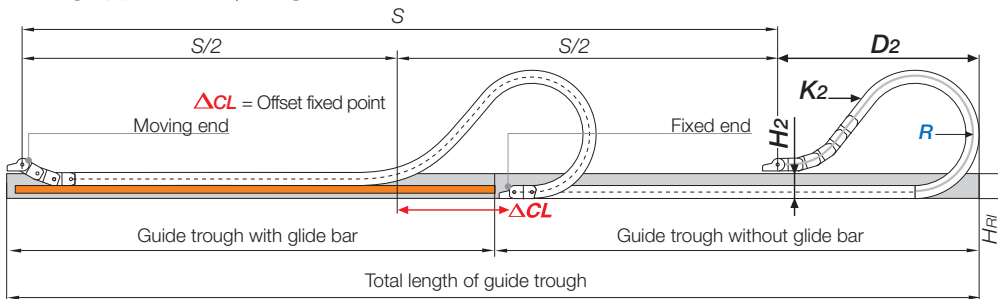

**Note:** For for long travel applications with more than 100 m we recommend to realize the engineering of such a plant by our technicians. In case of travels between 10 and 12 m we recommend a longer unsupported length. **Chain length**  $s/2 + K_2$

R	150*	200	250	300	350	400	500	550	600	1000
$H_2$	242	242	242	242	242	242	242	-	-	-
$D_{+25}$	550	800	1000	1200	1450	1600	2100	-	-	-
$K_2$	890	1330	1665	2000	2330	2660	3440	-	-	-
$\Delta CL$	189	389	539	689	889	989	1389	-	-	-

\*Radius not available for e-tubes

# E4.1 | Series E4.80 | Accessories

KMA mounting brackets | Attachment on all sides | pivoting | locking

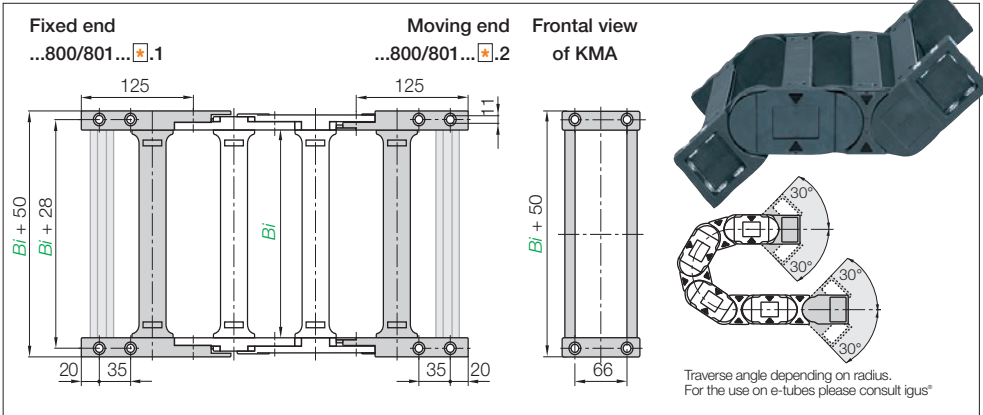

**KMA pivoting** | Standard | Recommended for unsupported and gliding applications  
**KMA locking** | Recommended for vertical hanging and standing applications

Width Index	Standard	Part No. full set KMA pivoting:	Part No. full set KMA locking:	Bi [mm]	Width Index	Standard	Part No. full set KMA pivoting:	Part No. full set KMA locking:	Bi [mm]
05.	▶	E4.- 800.05.1.12.C	E4.- 801.05.1.12.C	50	31.	▶	E4.- 800.31.1.12.C	E4.- 801.31.1.12.C	312
06.	▶	E4.- 800.06.1.12.C	E4.- 801.06.1.12.C	65	32.	▶	E4.- 800.32.1.12.C	E4.- 801.32.1.12.C	325
07.	▶	E4.- 800.07.1.12.C	E4.- 801.07.1.12.C	75	33.	▶	E4.- 800.33.1.12.C	E4.- 801.33.1.12.C	337
08.	▶	E4.- 800.08.1.12.C	E4.- 801.08.1.12.C	87	35.	▶	E4. R4.800.35.1.12.C	E4. R4.801.35.1.12.C	350
10.	▶	E4.- 800.10.1.12.C	E4.- 801.10.1.12.C	100	36.	▶	E4.- 800.36.1.12.C	E4.- 801.36.1.12.C	362
11.	▶	E4.- 800.11.1.12.C	E4.- 801.11.1.12.C	112	37.	▶	E4.- 800.37.1.12.C	E4.- 801.37.1.12.C	375
12.	▶	E4.- 800.12.1.12.C	E4.- 801.12.1.12.C	125	38.	▶	E4.- 800.38.1.12.C	E4.- 801.38.1.12.C	387
13.	▶	E4.- 800.13.1.12.C	E4.- 801.13.1.12.C	137	40.	▶	E4. R4.800.40.1.12.C	E4. R4.801.40.1.12.C	400
15.	▶	E4. R4.800.15.1.12.C	E4. R4.801.15.1.12.C	150	41.	▶	E4.- 800.41.1.12.C	E4.- 801.41.1.12.C	412
16.	▶	E4.- 800.16.1.12.C	E4.- 801.16.1.12.C	162	42.	▶	E4.- 800.42.1.12.C	E4.- 801.42.1.12.C	425
17.	▶	E4.- 800.17.1.12.C	E4.- 801.17.1.12.C	175	43.	▶	E4.- 800.43.1.12.C	E4.- 801.43.1.12.C	437
18.	▶	E4.- 800.18.1.12.C	E4.- 801.18.1.12.C	187	45.	▶	E4.- 800.45.1.12.C	E4.- 801.45.1.12.C	450
20.	▶	E4. R4.800.20.1.12.C	E4. R4.801.20.1.12.C	200	46.	▶	E4. R4.800.46.1.12.C	E4. R4.801.46.1.12.C	462
21.	▶	E4.- 800.21.1.12.C	E4.- 801.21.1.12.C	212	47.	▶	E4.- 800.47.1.12.C	E4.- 801.47.1.12.C	475
22.	▶	E4.- 800.22.1.12.C	E4.- 801.22.1.12.C	225	48.	▶	E4.- 800.48.1.12.C	E4.- 801.48.1.12.C	487
23.	▶	E4.- 800.23.1.12.C	E4.- 801.23.1.12.C	237	50.	▶	E4.- 800.50.1.12.C	E4.- 801.50.1.12.C	500
25.	▶	E4. R4.800.25.1.12.C	E4. R4.801.25.1.12.C	250	51.	▶	E4.- 800.51.1.12.C	E4.- 801.51.1.12.C	512
26.	▶	E4.- 800.26.1.12.C	E4.- 801.26.1.12.C	262	52.	▶	E4.- 800.52.1.12.C	E4.- 801.52.1.12.C	525
27.	▶	E4.- 800.27.1.12.C	E4.- 801.27.1.12.C	275	53.	▶	E4.- 800.53.1.12.C	E4.- 801.53.1.12.C	537
28.	▶	E4.- 800.28.1.12.C	E4.- 801.28.1.12.C	287	55.	▶	E4.- 800.55.1.12.C	E4.- 801.55.1.12.C	550
30.	▶	E4. R4.800.30.1.12.C	E4. R4.801.30.1.12.C	300	60.	▶	E4.- 800.60.1.12.C	E4.- 801.60.1.12.C	600

**Note\***: The E4.1 may end with either an inner or an outer side link. An outer side link always forms the first e-chain® link at the moving end. The Part No. depend on an even or odd numbers of links. Please insert: Index 1 (for odd) or 2 (for even). For the **preassembled** mode please add index **A**.

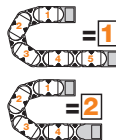

**E4.800.30.2.12.CA** Part No. structure  
 A... must be indicated on preassembled configurations  
 C-profile option  
 Full set  
 Even numbers of links  
 Width index  
 Series



# E4.1 | Series E4.80 | Accessories

Interior separation | New generation - Previous separation options ► [www.igus.eu/eu/E4.80](http://www.igus.eu/eu/E4.80)

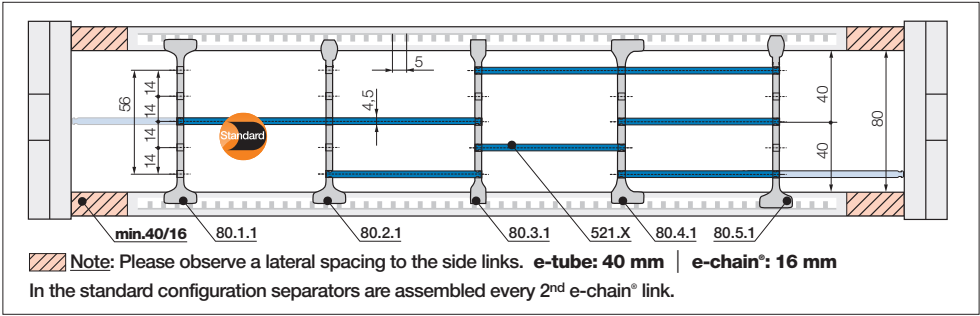
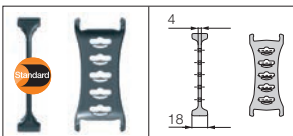
**Standard separator, wide base**

unassembled	80.1
assembled	80.1.1

**Standard - for all applications**  
Separator with a wide base for maximum locking strength and safe standing in e-chains® and e-tubes.

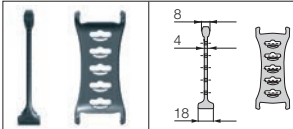

**Separator for QuickLock crossbar**

unassembled	80.2
assembled	80.2.1

**For even faster installation**  
Separator for igus® QuickLock crossbar 450.X.Q. Firm hold to one side with a wide base, narrow on opposed side for easy cable assembly (slight grip). For e-tubes also.

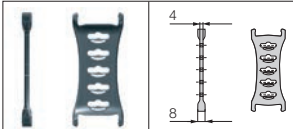

**Separator, narrow base**

unassembled	80.3
assembled	80.3.1

**For many thin cables**  
Separator with a narrow base for a large number of thin cables side by side. Saves space in e-chains® and e-tubes. Also available for QuickLock crossbars.

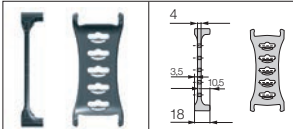

**Separator, asymmetrical**

unassembled	80.4
assembled	80.4.1

**For side-mounted applications**  
Asymmetrical separator, for defined distance. No additional spacers necessary for e-chains® and e-tubes.

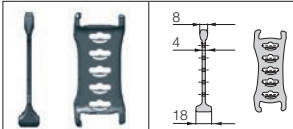

**Notch separator for notch crossbar**

unassembled	80.5
assembled	80.5.1

**Locks safely in 5 mm increments**  
Notch separator for the new notch crossbar, with scaling on the notch crossbars. For exact positioning in e-chains® and e-tubes. Recommended for side-mounted applications.

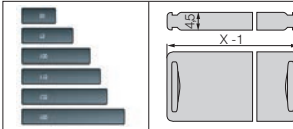

**Full-width shelf, lockable**

unassembled	520.X
assembled	521.X

**Horizontal separation**  
Shelf locks safely into separators on both ends, fixed width possible. Separators can be moved freely over the shelf in horizontal direction. Can be arranged at 5 different heights.

Lockable full-width shelves	Width X [mm]		Width X [mm]		Width X [mm]	
	unassembled	assembled	unassembled	assembled	unassembled	assembled
	050	520.050	521.050	125	520.125	521.125
	065	520.065	521.065	150	520.150	521.150
	075	520.075	521.075	175	520.175	521.175
	200	520.200	521.200	250	520.250	521.250
	300	520.300	521.300	450	520.450	521.450

## E4.1 | Series E4.80 | Further Accessories

### Extension links | Extender crossbars

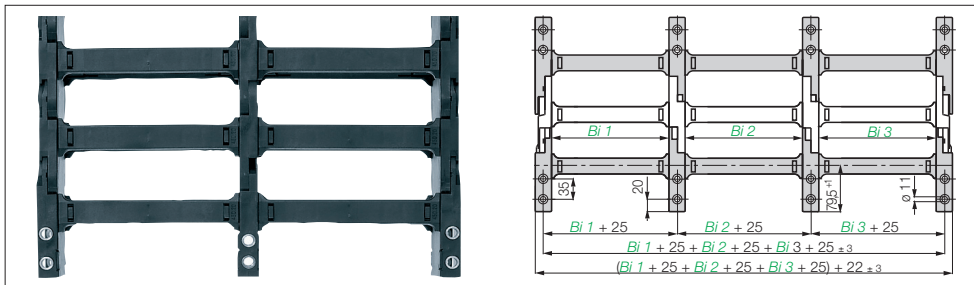

### Extension links | For extremely wide e-chains® up to 3,0 m

- Virtually limitless side-by-side attachment for high fill weights necessitate extremely wide e-chains® (up to 3000 mm)
- The unsupported length  $FL_G$  max. can be increased when additional loads are required

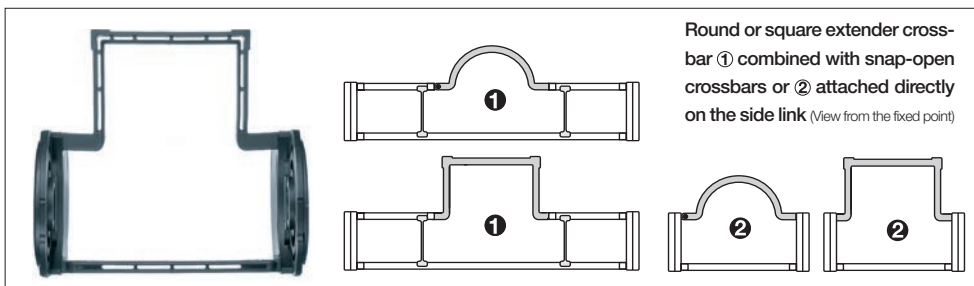

### Extender crossbars | Safe guiding for large hoses

- Suitable for hoses with a maximum outer diameter of 245 mm
- Gliding with crossbars assembled along outer radius and a special guide trough
- Extender crossbar 1 for snap-open crossbars or 2 attached directly on the side link

Part No. single part	Max Ø [mm] hose	Form	② Installation on side link	① Combination with snap-open crossbars
450.15.RHD115	115	○ round	no	yes
450.17.RD115	115	○ round	yes	no
450.25.D150	150	□ square	yes	no
450.30.D200	200	□ square	yes	no
450.35.D250	220	□ square	yes	no
450.40.D300	270	□ square	yes	no
450.20.HD150	150	□ square	no	yes
450.25.HD200	200	□ square	no	yes
450.30.HD250	220	□ square	no	yes

### E4 snapclip - clip-on cable binder

- For side-mounted applications
- Serves as a clip-on, lateral guide for hoses and cables on e-chains®
- The loops can be adjusted as required
- Compatible with many E4 e-chains®
- One clip and one locking band are needed for each e-chain® link. The complete range with order options ► [www.igus.eu/eu/E4.80](http://www.igus.eu/eu/E4.80)

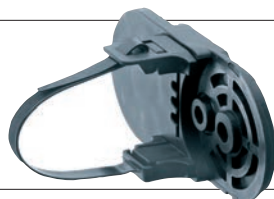

## The igus® e-chain® opener reduces assembly time

e-chain® opener tools for convenient opening and closing of E4 series igus® e-chains® ● Especially for e-chains® with many crossbars the assembly is much easier ● Especially in areas difficult to access mounting is simplified big savings in assembly time. Please call us or visit ► [www.igus.eu/eu/E4savetime](http://www.igus.eu/eu/E4savetime)

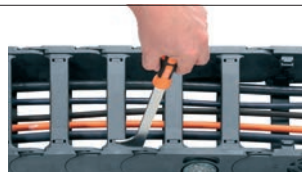

## Optional: Support tray tool kit.

### For support of the lower run.

Simple one-piece support trays according to your requirements and specification. The complete range with order options ► from page 714



## Heavy-Duty Version - For very long travels or high additional loads - Series 5050HD-R9850HD

● High side-mount stability due to undercut ● High torsional rigidity and tensile stability ● Robust Steel-Mounting Brackets ● For long-term operation in very humid environments. Please call us or visit ► [www.igus.eu/eu/5050HD](http://www.igus.eu/eu/5050HD)

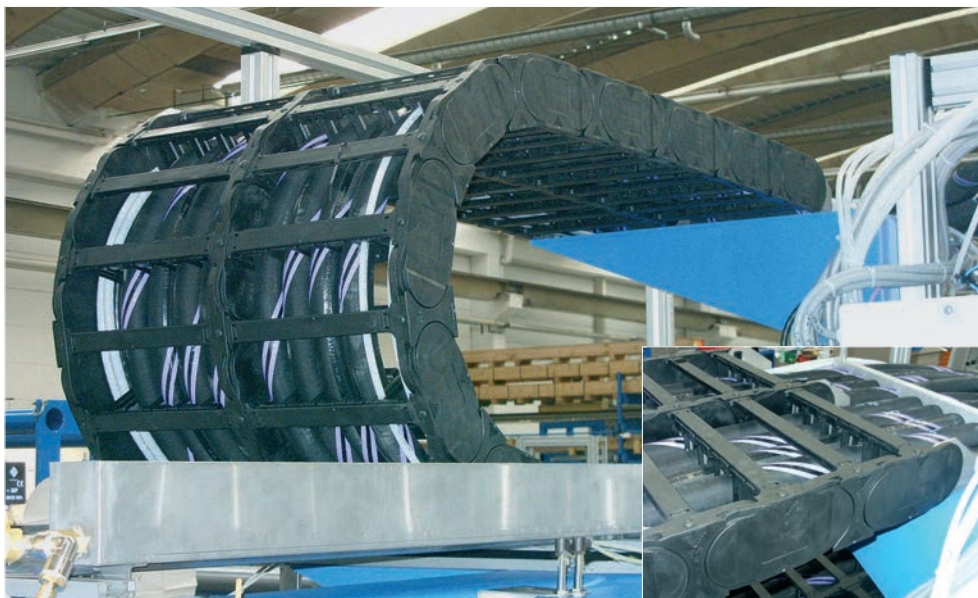
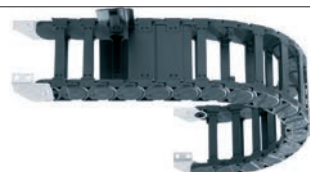

Series ES4.80 as a noise-optimized version with extension links. Unsupported application with high fill weights. Harnessed with rigid hydraulic hoses. Due to the optionally rubber pads, the max. noise-level can be reduced up to 9 dB(A)

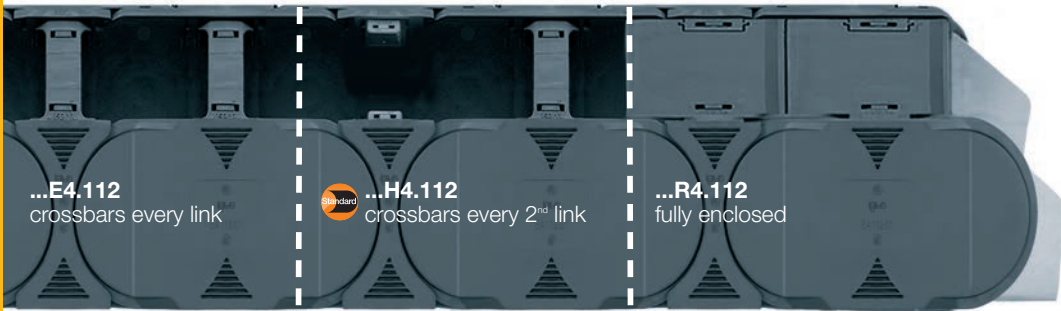

e-chains® | Series E4.112 crossbars every link (crossbars removable along both radii)

e-chains® | Series H4.112 crossbars every 2<sup>nd</sup> link (crossbars removable along both radii)

e-tubes | Series R4.112 fully enclosed (hinged snap-open removable lids along outer radius)

Part No. e-chains® / e-tubes	Bi [mm]	Ba [mm]	E4.112 [kg/m]	H4.112 [kg/m]	R4.112 [kg/m]
E4. H4. - 112.05. R.0	50	102	≈ 6,89	≈ 6,88	-
E4. H4. - 112.06. R.0	65	117	≈ 6,95	≈ 6,91	-
E4. H4. - 112.07. R.0	75	127	≈ 6,99	≈ 6,93	-
E4. H4. - 112.08. R.0	87	139	≈ 7,05	≈ 6,96	-
E4. H4. - 112.10. R.0	100	152	≈ 7,10	≈ 6,99	-
E4. H4. - 112.11. R.0	112	164	≈ 7,18	≈ 7,03	-
E4. H4. - 112.12. R.0	125	177	≈ 7,23	≈ 7,05	-
E4. H4. - 112.13. R.0	137	189	≈ 7,31	≈ 7,09	-
E4. H4. - 112.15. R.0	150	202	≈ 7,34	≈ 7,11	-
E4. H4. - 112.16. R.0	162	214	≈ 7,41	≈ 7,14	-
E4. H4. - 112.17. R.0	175	227	≈ 7,49	≈ 7,18	-
E4. H4. - 112.18. R.0	187	239	≈ 7,56	≈ 7,22	-
E4. H4. R4. 112.20. R.0	200	252	≈ 7,60	≈ 7,24	≈ 9,26
E4. H4. - 112.21. R.0	212	264	≈ 7,64	≈ 7,26	-
E4. H4. - 112.22. R.0	225	277	≈ 7,69	≈ 7,28	-
E4. H4. - 112.23. R.0	237	289	≈ 7,76	≈ 7,32	-
E4. H4. R4. 112.25. R.0	250	302	≈ 7,83	≈ 7,35	≈ 9,91
E4. H4. - 112.26. R.0	262	314	≈ 7,89	≈ 7,38	-
E4. H4. - 112.27. R.0	275	327	≈ 7,95	≈ 7,41	-
E4. H4. - 112.28. R.0	287	339	≈ 7,99	≈ 7,43	-
E4. H4. R4. 112.30. R.0	300	352	≈ 8,09	≈ 7,48	≈ 10,53

Part No. e-chains® / e-tubes	Bi [mm]	Ba [mm]	E4.112 [kg/m]	H4.112 [kg/m]	R4.112 [kg/m]
E4. H4. - 112.31. R.0	312	364	≈ 8,11	≈ 7,49	-
E4. H4. - 112.32. R.0	325	377	≈ 8,18	≈ 7,52	-
E4. H4. - 112.33. R.0	337	389	≈ 8,25	≈ 7,56	-
E4. H4. R4. 112.35. R.0	350	402	≈ 8,38	≈ 7,63	≈ 11,18
E4. H4. - 112.36. R.0	362	414	≈ 8,32	≈ 7,60	-
E4. H4. - 112.37. R.0	375	427	≈ 8,38	≈ 7,63	-
E4. H4. - 112.38. R.0	387	439	≈ 8,46	≈ 7,67	-
E4. H4. R4. 112.40. R.0	400	452	≈ 8,63	≈ 7,75	≈ 11,82
E4. H4. - 112.41. R.0	412	464	≈ 8,58	≈ 7,73	-
E4. H4. - 112.42. R.0	425	477	≈ 8,77	≈ 7,82	-
E4. H4. - 112.43. R.0	437	489	≈ 8,67	≈ 7,77	-
E4. H4. - 112.45. R.0	450	502	≈ 8,88	≈ 7,88	-
E4. H4. - 112.46. R.0	462	514	≈ 8,85	≈ 7,86	-
E4. H4. - 112.47. R.0	475	527	≈ 8,87	≈ 7,87	-
E4. H4. - 112.48. R.0	487	539	≈ 9,03	≈ 7,95	-
E4. H4. - 112.50. R.0	500	552	≈ 9,09	≈ 7,98	-
E4. H4. - 112.51. R.0	512	564	≈ 9,03	≈ 7,95	-
E4. H4. - 112.52. R.0	525	577	≈ 9,15	≈ 8,01	-
E4. H4. - 112.53. R.0	537	589	≈ 9,20	≈ 8,04	-
E4. H4. - 112.55. R.0	550	602	≈ 9,47	≈ 8,17	-
E4. H4. - 112.60. R.0	600	652	≈ 9,62	≈ 8,25	-

\*Radius not available for e-tubes

Available bending radii  $R$  [mm] 200\* | 250 | 300 | 350 | 400 | 450 | 500 | 550 | 600 | 750 | 1000

Supplement Part No. with required radius ( $R$ ). Examples:

E4.112.30.300.0 = e-chain® with crossbars every link, inner width  $Bi$  300 mm, radius  $R$  300 mm, color black

H4.112.30.300.0 = e-chain® with crossbars every 2<sup>nd</sup> link, inner width  $Bi$  300 mm, radius  $R$  300 mm, color black

R4.112.30.300.0 = e-tube fully enclosed, inner width  $Bi$  300 mm, radius  $R$  300 mm, color black



## Unsupported applications | Short travels

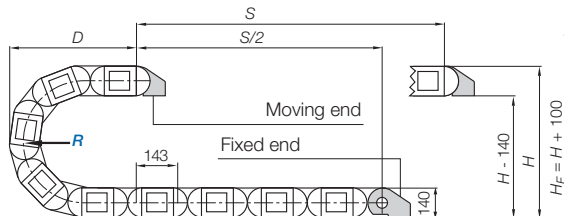
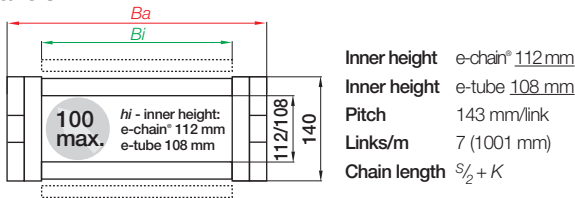
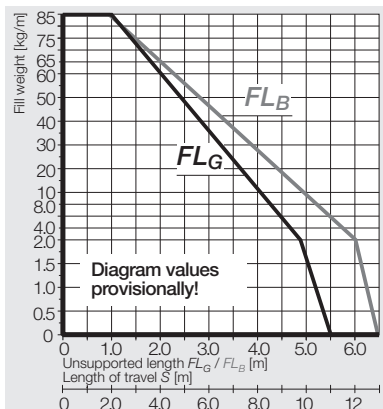

R	200	250	300	350	400	450	500	550	600	750	1000
H	545	645	745	845	945	1045	1145	1245	1345	1645	2145
D	415	465	515	565	615	665	715	765	815	965	1215
K	915	1075	1230	1390	1545	1700	1860	2015	2175	2645	3430

The required clearance height:  $H_F = H + 100$  mm (with 5,0 kg/m fill weight)

## Gliding applications | Long travels from 14 m to max. 450 m

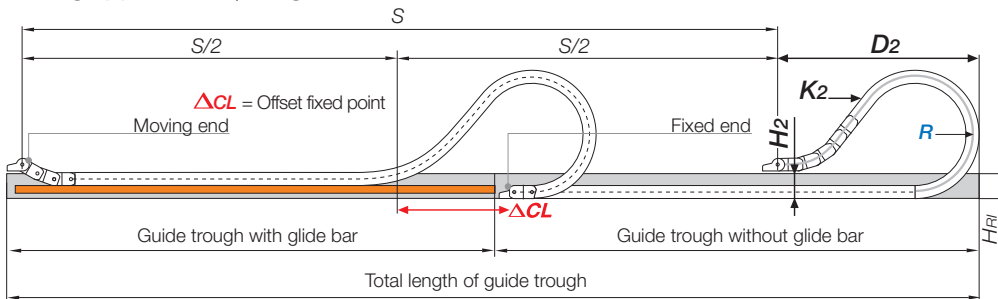

**Note:** For long travel applications with more than 100 m we recommend to realize the engineering of such a plant by our technicians. In case of travels between 11 and 14 m we recommend a longer unsupported length. **Chain length**  $s_2 + K_2$

R	200	250	300	350	400	450	500	550	600	750	1000
H <sub>2</sub>	325	325	325	325	325	325	325	325	325	-	-
D <sub>2</sub>	900	1000	1100	1250	1450	1600	1700	1900	2050	-	-
K <sub>2</sub>	1573	1716	1859	2288	2574	2860	3146	3432	3861	-	-
ΔCL	450	500	550	650	800	900	950	1100	1200	-	-

# E4.1 | Series E4.112 | Accessories

## Steel mounting brackets | pivoting | locking

Fixed end	Moving end
E4.11210.1 <b>locking</b>	E.11210.2 <b>locking</b>
E4.11210.3 <b>pivoting</b>	E4.11210.4 <b>pivoting</b>

**Polymer mounting brackets are in preperation - please ask igus® for more information.**

**Steel pivoting | Recommended for unsupported, gliding and vertical hanging applications**  
**Steel locking | Recommended for unsupported, gliding, vertical hanging, standing applications**

E4.11210.1.34.VS.E Full set (both sides) for e-chain®, ending with outer side link

E4.11210.2.34.VS.E Full set (both sides) for e-chain®, beginning with outer side link (moving end), ending with inner side link (fixed end)

E4.11210.3 Mounting bracket set moving end (one side) for outer side link

E4.11210.4 Mounting bracket set fixed end (one side) for inner side link

E4.11210.1.12.VS.E Full set (both sides) for e-chain®, ending with outer side link

E4.11210.2.12.VS.E Full set (both sides) for e-chain®, beginning with outer side link (moving end), ending with inner side link (fixed end)

E4.11210.1 Mounting bracket set moving end (one side) for outer side link

E4.11210.2 Mounting bracket set fixed end (one side) for inner side link

**Note:** By ordering steel mounting brackets in combination with an e-chain® / e-tube, they will be delivered assembled.

Stainless steel version available - please add index .E (Material: stainless steel 1.4301)

**Note:** Depending on the e-chain® length, the carrier will end with 1 outer or 2 inner side links. For the best appearance, make sure the e-chain® ends with 1 outer side link whenever possible. (with odd number of links)



**Strain relief** e.g. clamps, tiewrap plates, nuggets and plug-in clips are available from stock. The complete chainfix range with order options ► from page 630



# E4.1 | Series E4.112 | Accessories

Interior separation | Option 1 | Separators and spacers (option 2 ► next page)

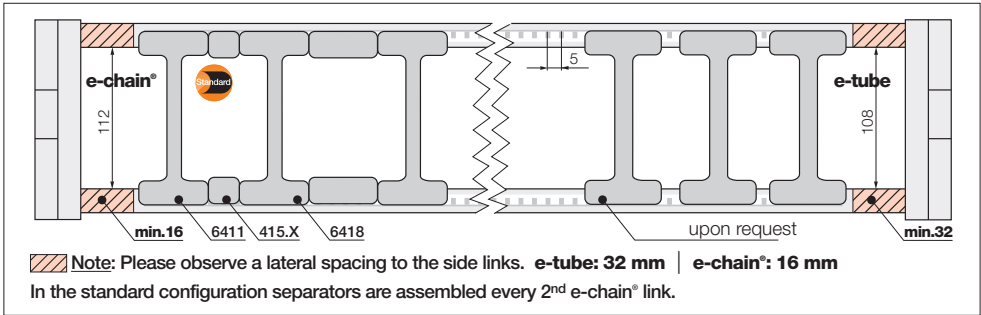

		<b>Separator for e-chains*</b> unassembled <b>6401</b> assembled <b>6411</b>
--	--	--

## Separator 6401 (e-chains\* only)

For a vertical subdivision. Offers safe stability due to its wide base design, also when used with thick cables or hoses (Separator for e-tubes 1608 upon request).

		<b>Locking separator for e-chains*</b> unassembled <b>6408</b> assembled <b>6418</b>
--	--	--

## Locking separator 6408 (e-chains\* only)

For applications exposed to very high humidity (> 85%). Locks with extra retention force. Tip: one locking separator per e-chain\* link for better mounting.

		<b>Spacer* for e-chains*</b> unassembled <b>405.XX</b> assembled <b>415.XX</b>
--	--	--

## Spacer\* 405.XX (e-chains\* only)

Separators can be fixed in position by spacers. The available interior height is reduced by 2 mm per spacer (4 mm when spacers are fitted on both sides). To avoid this, the parts can also be installed from the outside on the opening crossbar. (not for long travel applications). **XX = width of the spacer** (please choose between 10, 15, 20, 30, 40 mm).

		<b>Rollclip for e-chains*</b> unassembled <b>489.27</b> assembled <b>490.27</b>
--	--	---

## Additional elements - interior separation

### Rollclip

Minimizes abrasion of particularly sensitive hoses - simply clamped onto the opening crossbar. The movable rollers compensate for relative movement between the e-chain\* and hose.

# E4.1 | Series E4.112 | Accessories

## Interior separation | Option 2 | Shelves

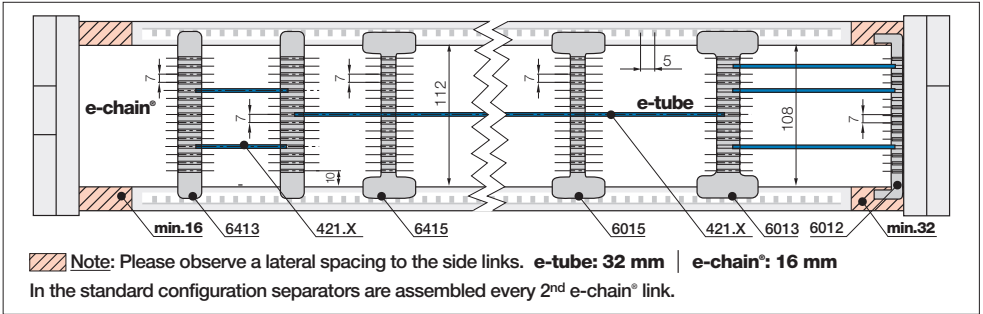

	<p><b>Open, slotted separator for e-chains®</b></p> <p>unassembled <b>6405</b></p> <p>assembled <b>6415</b></p>
--	---

**Open, slotted separator 6405 (unilateral open)**  
Fast assembly - can be retrofitted into an existing interior separation system without a need for dismantling the interior separators. During an installation of open slotted separators, the top and bottom notches cannot be occupied by shelves. e-chains® only.

	<p><b>Open, slotted separator for e-tubes</b></p> <p>unassembled <b>6005</b></p> <p>assembled <b>6005</b></p>
--	---

**Open, slotted separator 6005 (e-tubes only, unilateral open)**  
Works like open, slotted separator 6405 on e-tube 1608.

	<p><b>Middle plate for e-chains®</b></p> <p>unassembled <b>6403</b></p> <p>assembled <b>6413</b></p>
--	--

**Middle plate 6403 (e-chains® only)**  
To achieve a modular shelving the shelf 420.X can be arranged at 15 different heights (in 7 mm increments).

	<p><b>Middle plate for e-tubes</b></p> <p>unassembled <b>6003</b></p> <p>assembled <b>6013</b></p>
--	--

**Middle plate 6003 (e-tubes only)**  
Works like middle plate 6403 on e-tube 1608.

	<p><b>Side plate for e-chains®/e-tubes</b></p> <p>unassembled <b>6002</b></p> <p>assembled <b>6012</b></p>
--	--

**Side plate 6002 (e-chains®/e-tubes)**  
Works like middle plate.  
Allows modular shelving close to the side links.

	<p><b>Shelf (18-149 mm)</b></p> <p>unassembled <b>420.X</b></p> <p>assembled <b>421.X</b></p>
--	---

**Shelf 420.X**  
For horizontal separation. Shelves of various widths can be arranged at 15 different heights (in 7 mm increments). - see table below.

### Shelves

Width X	unassembled	assembled	Width X	unassembled	assembled	Width X	unassembled	assembled	Width X	unassembled	assembled
018	420.18	421.18	033	420.33	421.33	075	420.75	421.75	150	420.150	421.150
023	420.23	421.23	043	420.43	421.43	088	420.88	421.88	175	420.175	421.175
025	420.25	421.25	050	420.50	421.50	100	420.100	421.100	187	420.187	421.187
028	420.28	421.28	062	420.62	421.62	125	420.125	421.125	200	420.200	421.200

## Extension links | Extender crossbars

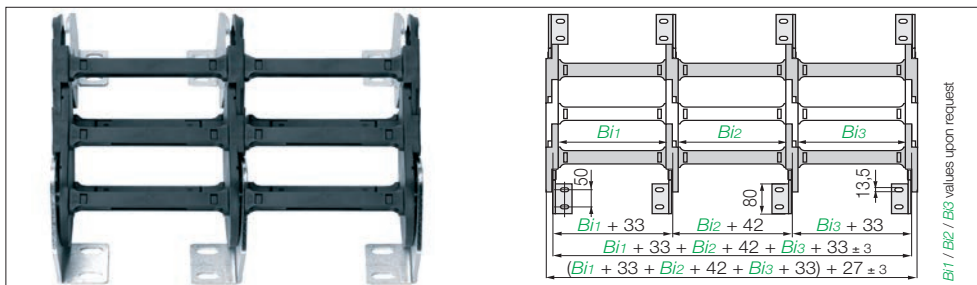

### Extension links | For extremely wide e-chains® up to 3,0 m

- Virtually limitless side-by-side attachment for high fill weights necessitate extremely wide e-chains® (up to 3000 mm)
- The unsupported length  $FL_G$  max. can be increased when additional loads are required

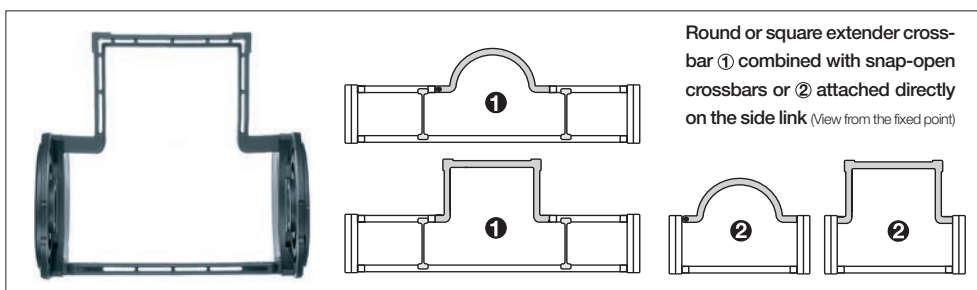

### Extender crossbars | Safe guiding for large hoses

- Suitable for hoses with a maximum outer diameter of 245 mm
- Gliding with crossbars assembled along outer radius and a special guide trough
- Extender crossbar ① for snap-open crossbars or ② attached directly on the side link

Part No. single part	Max Ø [mm] hose	Form	② Installation on side link	① Combination with snap-open crossbars
450.15.RHD115	115	○ round	no	yes
450.17.RD115	115	○ round	yes	no
450.25.D150	150	□ square	yes	no
450.30.D200	200	□ square	yes	no
450.35.D250	220	□ square	yes	no
450.40.D300	270	□ square	yes	no
450.20.HD150	150	□ square	no	yes
450.25.HD200	200	□ square	no	yes
450.30.HD250	220	□ square	no	yes

### The igus® e-chain® opener reduces assembly time

e-chain® opener tools for convenient opening and closing of E4 series igus® e-chains® ● Especially for e-chains® with many crossbars the assembly is much easier ● Especially in areas difficult to access mounting is simplified big savings in assembly time. Please call us or visit ► [www.igus.eu/eu/E4savetime](http://www.igus.eu/eu/E4savetime)



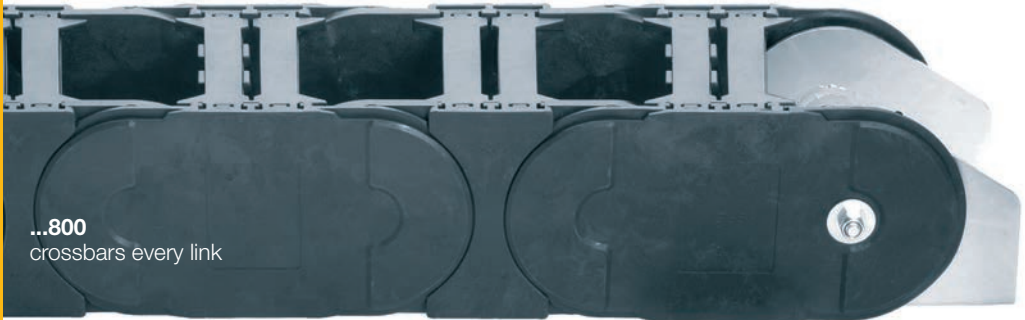

...800  
crossbars every link

e-chains® | Series 800 crossbars every link (crossbars removable along both radii)

Part No. e-chains®	<i>Bi</i> [mm]	<i>Ba</i> [mm]	800 [kg/m]	Part No. e-chains®	<i>Bi</i> [mm]	<i>Ba</i> [mm]	800 [kg/m]
800. 20. <i>R.0</i>	200	260	≈ 15,09	800. 40. <i>R.0</i>	400	460	≈ 16,74
800. 25. <i>R.0</i>	250	310	≈ 15,50	800. 45. <i>R.0</i>	450	510	≈ 16,88
800. 30. <i>R.0</i>	300	360	≈ 15,89	800. 50. <i>R.0</i>	500	560	≈ 17,23
800. 32. <i>R.0</i>	325	385	≈ 16,05	800. 55. <i>R.0</i>	550	610	≈ 17,63
800. 35. <i>R.0</i>	350	410	≈ 16,22	800. 60. <i>R.0</i>	600	660	≈ 18,19

Available bending radii *R* [mm] 325 | 350 | 400 | 450 | 500 | 600 | 750 | 1000

Supplement Part No. with required radius (*R*). Example:

800.40.400.0 = e-chain® with crossbars every link, inner width *Bi* 450 mm, radius *R* 400 mm, color black



## Unsupported applications | Short travels

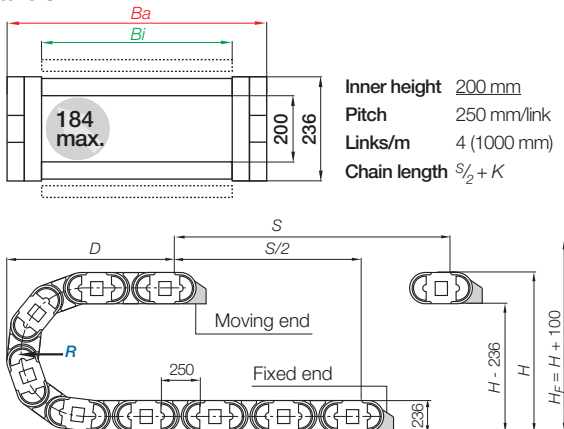
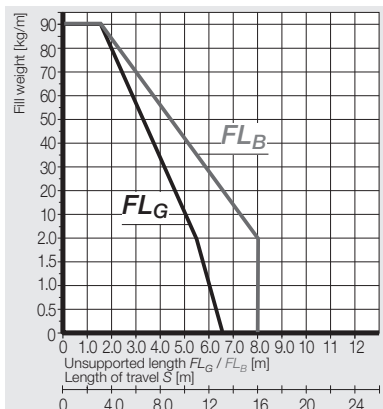

$R$	325	350	400	450	500	600	750	1000
$H$	886	936	1036	1136	1236	1436	1736	2236
$D$	818	843	893	943	993	1093	1243	1493
$K$	1525	1600	1760	1915	2075	2385	2860	3645

The required clearance height:  $H_f = H + 100$  mm (with 5,0 kg/m fill weight)

## Gliding applications | Long travels from 15 m to max. 450 m

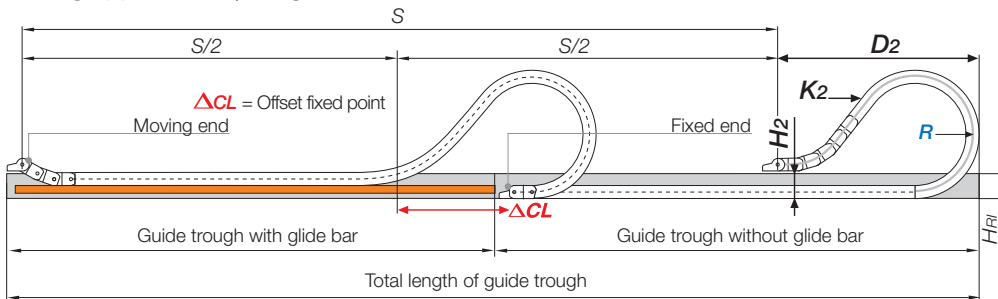

**Note:** For for long travel applications with more than 100 m we recommend to realize the engineering of such a plant by our technicians. In case of travels between 12 and 15 m we recommend a longer unsupported length. Chain length  $S/2 + K_2$

$R$	325	350	400	450	500	600	750	1000
$H_2$	580	580	580	580	580	580	580	580
$D_2 + 25$	1030	1080	1380	1610	2000	2480	*	*
$K_2$	2000	2000	2500	3000	3250	4000	*	*
$\Delta CL$	250	300	550	750	1050	1400	*	*

\*Values upon request

# E4.1 | Series 800 | Accessories

## Steel mounting brackets | pivoting

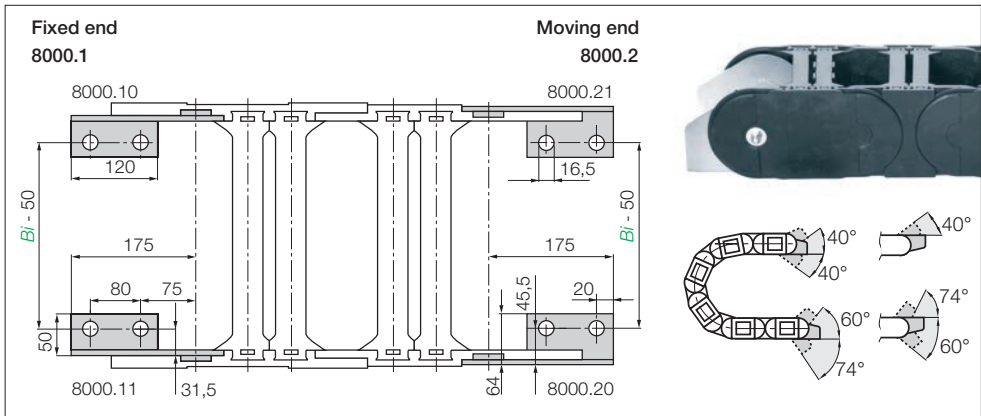

**Steel | Recommended for unsupported, gliding, vertical hanging, standing applications**

Part No.	Mounting bracket
8000.1.12.E	Full set (both sides) for e-chain®, ending with outer side link
8000.3.12.E	Full set (both sides) for e-chain®, beginning with outer side link (moving end), ending with inner side link (fixed end)
8000.1.E	Mounting bracket set <b>moving end</b> (one side) for outer side link
8000.2.E	Mounting bracket set <b>fixed end</b> (one side) for inner side link

**Note:** By ordering steel mounting brackets in combination with an e-chain® / e-tube, they will be delivered assembled  
Stainless steel version available - please add index **.E** (Material: stainless steel 1.4301)

**Note:** Depending on the e-chain® length, the carrier will end with **1** outer or **3** inner side links. For the best appearance, make sure the e-chain® ends with **1** outer side link whenever possible. (with odd number of links)



**Strain relief** e.g. clamps, tiewrap plates, nuggets and plug-in clips are available from stock. The complete chainfix range with order options ► from page 630

## Interior separation

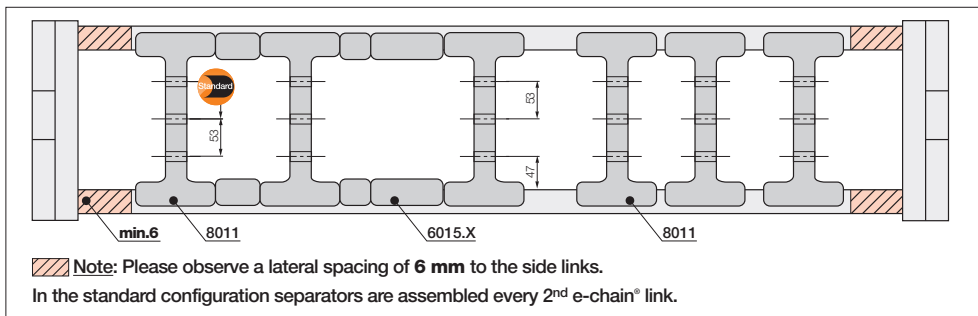

	<p><b>Separator for e-chains®</b></p> <p>unassembled <b>8001</b></p> <p>assembled <b>8011</b></p>
	<p><b>Spacer* for e-chains®</b></p> <p>unassembled <b>6005.XX</b></p> <p>assembled <b>6015.XX</b></p>

### Separator 8001

For a vertical subdivision. Offers safe stability due to its wide base design, also when used with thick cables or hoses.

### Spacer\* 6005.XX

Separators can be fixed in position by spacers. The available interior height is reduced by 2 mm per spacer (4 mm when spacers are fitted on both sides). To avoid this, the parts can also be installed from the outside on the opening crossbar. (not for long travel applications). **XX = width of the spacer** (please choose between 10, 15, 20 mm).

## Modular E4 shelving system for Series 800

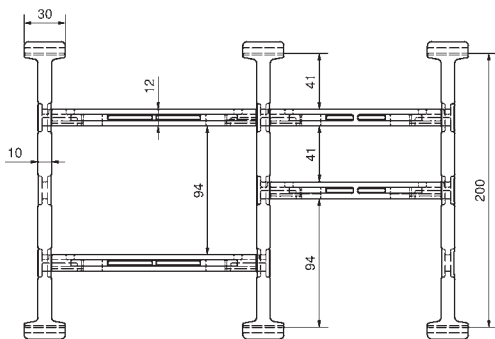

- Secure guide even for large cables
- Easy assembly
- Robust, also for large cable diameters
- Modular
- Widths from 50 - 600 mm

Part No. unassembled	Part No. assembled	Snap in tab	Part No. separator	Part No. crossbar	Width [mm]
8001H1	8011H1	single-sided	8001	450.XX.A	50-600
8001H2	8011H2	double-sided	8001	450.XX.A	50-600

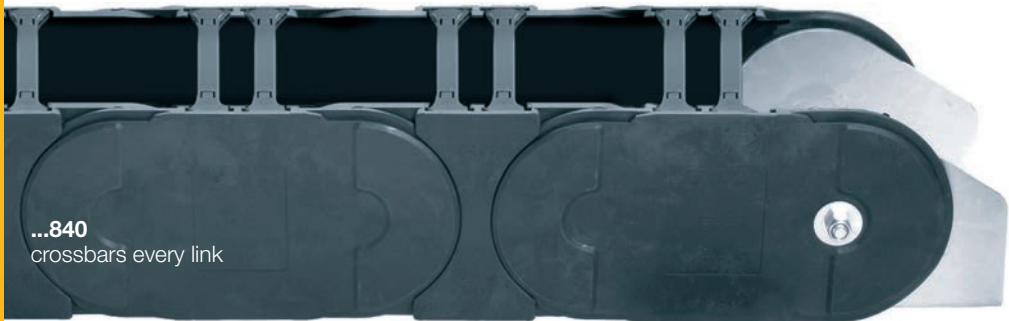

e-chains® | Series 840 crossbars every link (crossbars removable along both radii)

Part No. e-chains®	<i>Bi</i> [mm]	<i>Ba</i> [mm]	840 [kg/m]	Part No. e-chains®	<i>Bi</i> [mm]	<i>Ba</i> [mm]	840 [kg/m]
840. 13. <i>R.0</i>	100	160	≈ 13,84	840. 36. <i>R.0</i>	325	385	≈ 15,09
840. 15. <i>R.0</i>	113	173	≈ 13,87	840. 37. <i>R.0</i>	338	398	≈ 15,11
840. 16. <i>R.0</i>	125	185	≈ 13,95	840. 38. <i>R.0</i>	350	410	≈ 15,15
840. 17. <i>R.0</i>	138	198	≈ 14,04	840. 40. <i>R.0</i>	363	423	≈ 15,34
840. 18. <i>R.0</i>	150	210	≈ 14,13	840. 41. <i>R.0</i>	375	435	≈ 15,39
840. 20. <i>R.0</i>	163	223	≈ 14,17	840. 42. <i>R.0</i>	388	448	≈ 15,50
840. 21. <i>R.0</i>	175	235	≈ 14,22	840. 43. <i>R.0</i>	400	460	≈ 15,57
840. 22. <i>R.0</i>	188	248	≈ 14,27	840. 45. <i>R.0</i>	413	473	≈ 15,63
840. 23. <i>R.0</i>	200	260	≈ 14,35	840. 46. <i>R.0</i>	425	485	≈ 15,69
840. 25. <i>R.0</i>	213	273	≈ 14,43	840. 47. <i>R.0</i>	438	498	≈ 15,72
840. 26. <i>R.0</i>	225	285	≈ 14,49	840. 48. <i>R.0</i>	450	510	≈ 15,80
840. 27. <i>R.0</i>	238	298	≈ 14,57	840. 50. <i>R.0</i>	463	523	≈ 15,87
840. 28. <i>R.0</i>	250	310	≈ 14,61	840. 51. <i>R.0</i>	475	535	≈ 15,91
840. 30. <i>R.0</i>	263	323	≈ 14,72	840. 52. <i>R.0</i>	488	548	≈ 15,93
840. 31. <i>R.0</i>	275	335	≈ 14,75	840. 53. <i>R.0</i>	500	560	≈ 16,00
840. 32. <i>R.0</i>	288	348	≈ 14,82	840. 55. <i>R.0</i>	513	573	≈ 16,31
840. 33. <i>R.0</i>	300	360	≈ 14,91	840. 60. <i>R.0</i>	563	623	≈ 16,47
840. 35. <i>R.0</i>	313	373	≈ 15,06				

Available bending radii *R* [mm] 325 | 350 | 400 | 450 | 500 | 600 | 750 | 1000

Supplement Part No. with required radius (*R*). Example:

840.40.400.0 = e-chain® with crossbars every link, inner width *Bi* 363 mm, radius *R* 400 mm, color black





## Unsupported applications | Short travels

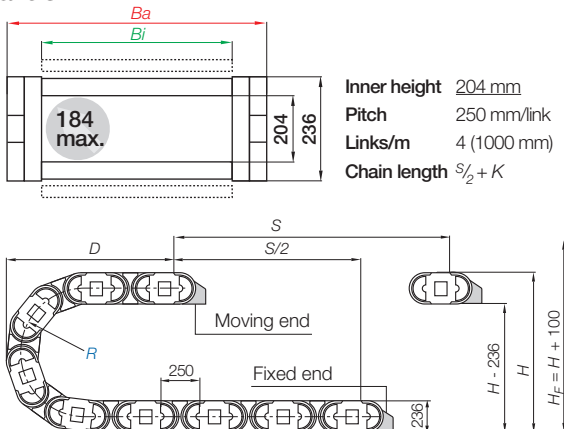
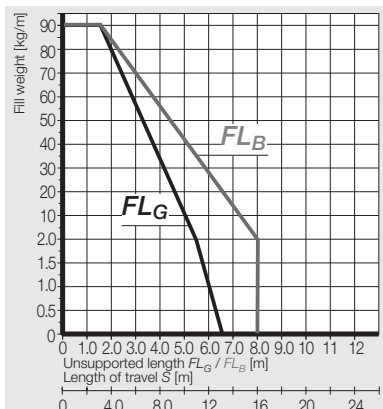

R	325	350	400	450	500	600	750	1000
H	886	936	1036	1136	1236	1436	1736	2236
D	818	843	893	943	993	1093	1243	1493
K	1525	1600	1760	1915	2075	2385	2860	3645

The required clearance height:  $H_f = H + 100$  mm (with 5,0 kg/m fill weight)

## Gliding applications | Long travels from 15 m to max. 450 m

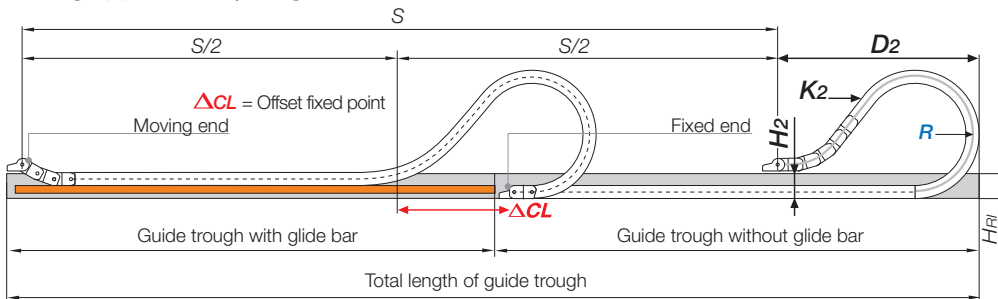

**Note:** For long travel applications with more than 100 m we recommend to realize the engineering of such a plant by our technicians. In case of travels between 12 and 15 m we recommend a longer unsupported length. **Chain length**  $S/2 + K_2$

R	325	350	400	450	500	600	750	1000
H <sub>2</sub>	580	580	580	580	580	580	580	580
D <sub>2</sub> +25	1030	1080	1380	1610	2000	2480	*	*
K <sub>2</sub>	2000	2000	2500	3000	3250	4000	*	*
ΔCL	250	300	550	750	1050	1400	*	*

\*Values upon request

# E4.1 | Series 840 | Accessories

## Steel mounting brackets | pivoting

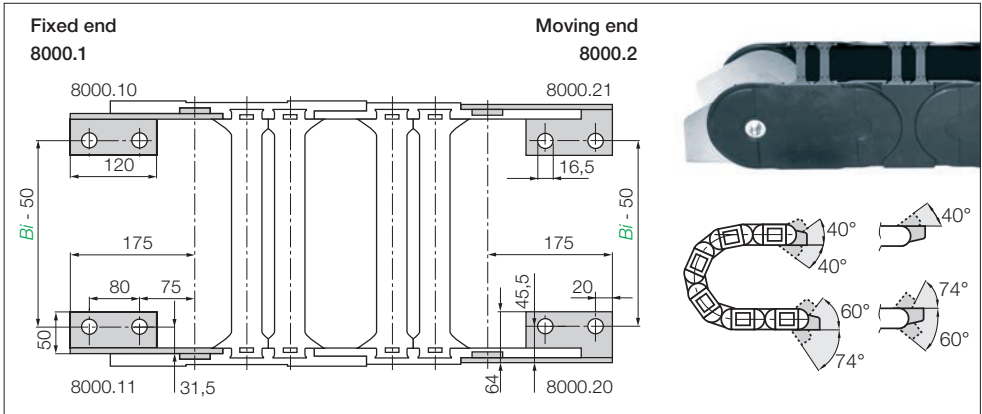

**Steel | Recommended for unsupported, gliding, vertical hanging, standing applications**

Part No.	Mounting bracket
8000.1.12.E	Full set (both sides) for e-chain®, ending with outer side link
8000.3.12.E	Full set (both sides) for e-chain®, beginning with outer side link (moving end), ending with inner side link (fixed end)
8000.1.E	Mounting bracket set <b>moving end</b> (one side) for outer side link
8000.2.E	Mounting bracket set <b>fixed end</b> (one side) for inner side link

**Note:** By ordering steel mounting brackets in combination with an e-chain® / e-tube, they will be delivered assembled  
Stainless steel version available - please add index **.E** (Material: stainless steel 1.4301)

**Note:** Depending on the e-chain® length, the carrier will end with **1** outer or **3** inner side links. For the best appearance, make sure the e-chain® ends with **1** outer side link whenever possible. (with odd number of links)

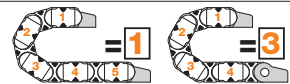

**Strain relief** e.g. clamps, tiewrap plates, nuggets and plug-in clips are available from stock. The complete chainfix range with order options ► from page 630

## Interior separation

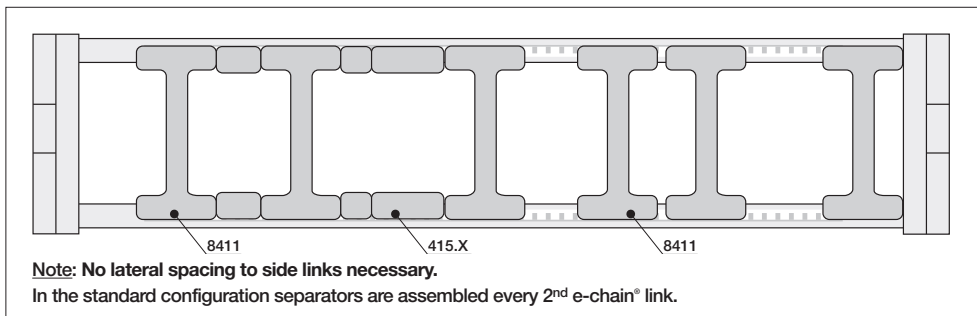

		<b>Separator for e-chains®</b> unassembled <b>8401</b> assembled <b>8411</b>
--	--	--

### Separator 8401

For a vertical subdivision. Offers safe stability due to its wide base design, also when used with thick cables or hoses.

		<b>Spacer* for e-chains®</b> unassembled <b>405.XX</b> assembled <b>415.XX</b>
--	--	--

### Spacer\* 405.XX

Separators can be fixed in position by spacers. The available interior height is reduced by 2 mm per spacer (4 mm when spacers are fitted on both sides). To avoid this, the parts can also be installed from the outside on the opening crossbar. (not for long travel applications). **XX = width of the spacer** (please choose between 10, 15, 20, 30, 40 mm).

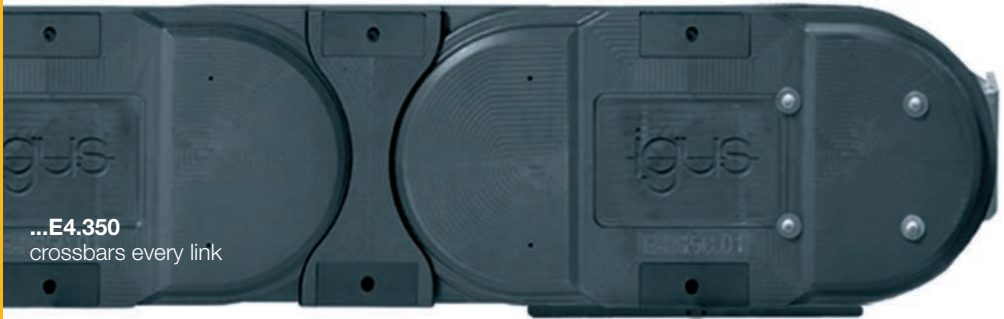

### e-chains® | Series E4.350 crossbars every link (crossbars removable along both radii)

Part No. e-chains®	<i>Bi</i> [mm]	<i>Ba</i> [mm]	E4.350 [kg/m]
E4.350. 400. <i>R.0</i>	400	540	61,9
E4.350. 500. <i>R.0</i>	500	640	65,7
E4.350. 600. <i>R.0</i>	600	740	69,6

Part No. e-chains®	<i>Bi</i> [mm]	<i>Ba</i> [mm]	E4.350 [kg/m]
E4.350. 700. <i>R.0</i>	700	840	73,4
E4.350. 800. <i>R.0</i>	800	940	77,2

Available bending radii *R* [mm] 500 | 750 | 1000

Supplement Part No. with required radius (*R*). Example:

E4.350.500.500.0 = e-chain® with crossbars every link, inner width *Bi* 500 mm, radius *R* 500 mm, color black



**Largest\* all-plastic e-chain®.**

**Extreme inner height: 350 mm**

**Series E4.350** - Please ask for additional support for this series. An optimal dimensioning is done by the igus® project team. (\*Issue 11/2011) ► Phone +49- (0) 22 03-96 49-800



## Unsupported applications | Short travels

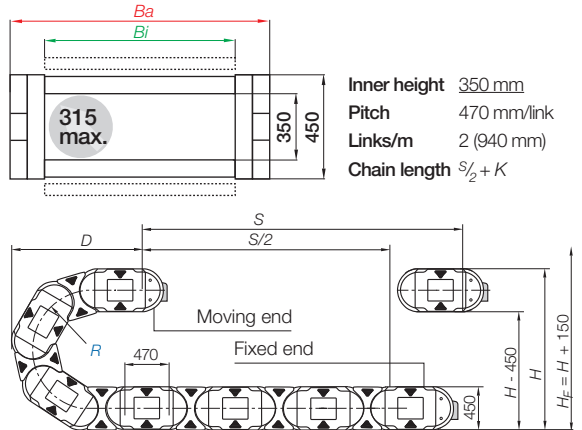
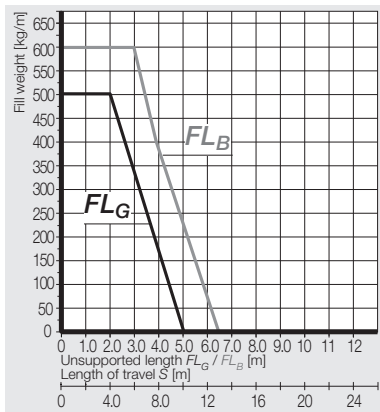

R	500	750	1000
$H_{+25}^0$	1450	1950	2450
D	1430	1680	1930
K	2515	3300	4085

The required clearance height:  $H_F = H + 150$  mm

## For long travel gliding applications - please consult igus®



Cleaning of a port basin in Antwerp. On a stroke of 138 meters an e-chain® Series E4.350 guides cables and hoses with a total additional load of 98 kg/m

# E4.1 | Series E4.350 | Accessories

## Steel mounting brackets | pivoting

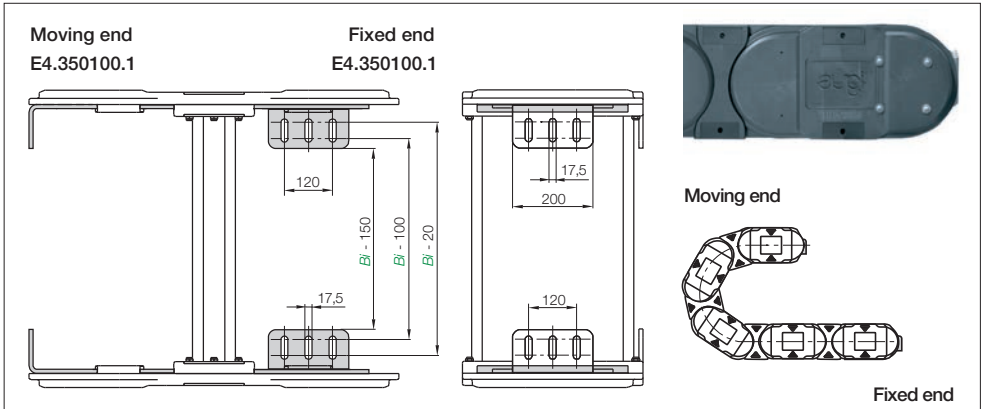

### Steel mounting brackets

Part No.	Mounting bracket
E4.350100.1.12.E	Full set (both sides) for e-chain®, ending with outer side link
E4.350100.1.E	Mounting bracket set (one side) for outer side link

**Note:** By ordering steel mounting brackets in combination with an e-chain® / e-tube, they will be delivered assembled  
Stainless steel version available - please add index **.E** (Material: stainless steel 1.4301)



Robust steel mounting bracket for secure fixation and connection

## Interior separation

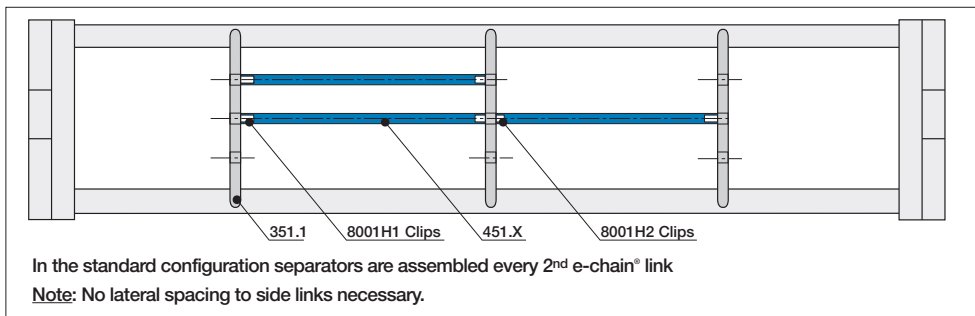

**Separator for vertical subdivision**  
 unassembled **350.1**  
 assembled **351.1**

### Separator for vertical subdivision 350.1

For a vertical subdivision 450.X at 3 different heights.

**Shelf for horizontal subdivision**  
 unassembled **450.X**  
 assembled **451.X**

### Shelf for horizontal subdivision 450.X

For horizontal separation with clips separators for vertical subdivision. Horizontal shelves of various widths can be arranged at 3 different heights.

### Horizontal shelves

Width X [mm]	unassembled	assembled	Width X [mm]	unassembled	assembled	Width X [mm]	unassembled	assembled
50	450.50	451.50	225	450.225	451.225	400	450.400	451.400
65	450.65	451.65	237	450.237	451.237	412	450.412	451.412
75	450.75	451.75	250	450.250	451.250	425	450.425	451.425
87	450.87	451.87	262	450.262	451.262	437	450.437	451.437
100	450.100	451.100	275	450.275	451.275	450	450.450	451.450
112	450.112	451.112	287	450.287	451.287	462	450.462	451.462
125	450.125	451.125	300	450.300	451.300	475	450.475	451.475
137	450.137	451.137	312	450.312	451.312	487	450.487	451.487
150	450.150	451.150	325	450.325	451.325	500	450.500	451.500
162	450.162	451.162	337	450.337	451.337	512	450.512	451.512
175	450.175	451.175	350	450.350	451.350	525	450.525	451.525
187	450.187	451.187	362	450.362	451.362	537	450.537	451.537
200	450.200	451.200	375	450.375	451.375	550	450.550	451.550
212	450.212	451.212	387	450.387	451.387	600	450.600	451.600

Universal: Attachment on all sides

High stability: "Undercut" design

Space-saving: More usable space with less installation space

Easy access: Openable on inner- and outer radius

Efficient: Less weight, enhanced dynamics

Convenient: Crossbars are openable on both sides

No camber: No rework due to special design principle

Straight run: Due to inner/outer link principle

Low noise operation: Due to integrated "brakes"

## E4.1 light - High dynamics and cost effective

The E4.1 light series was developed to incorporate the advantages of both E2/000 and E4.1 series. It has all the design features that make the E4.1 so strong, and combines them with the comfortable opening mechanism of the E2/000, a bigger usable surface, and a low price.

- Less weight, enhanced dynamics possible
- Optimized interior-exterior dimensions ratio due to narrower outer links and optimized crossbar shape
- Inner diameter completely accessible for easy filling
- Unique side plate with tongue and groove system
- Cost-effective
- Short assembly time
- Inner heights 38 mm and 48 mm

### Typical industries and applications

- Low-cost alternative to E4.1
- For unsupported applications
- Strength between series E2/000 and E4.1



Electrically conductive ESD/ATEX versions upon request



Low noise operation: Due to integrated "brakes"



High torsional rigidity





# E4.1 light | Features | Accessories

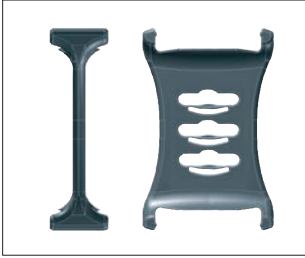

New generation interior separation - even more cable-friendly

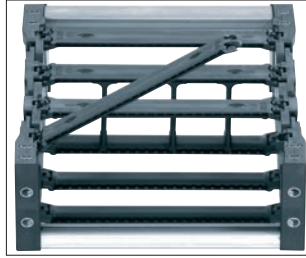

New snap-open mechanism, Series E4.1 light choice of snap-open on left or right

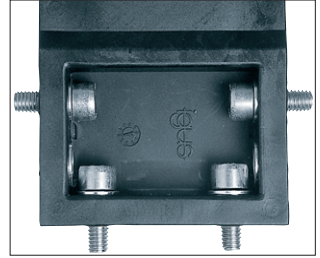

KMA mounting brackets with attachment options on all sides

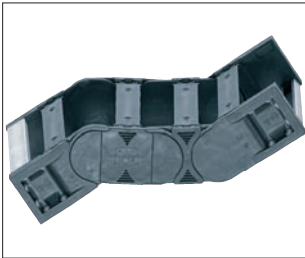

Pivoting and locking KMA mounting brackets are available

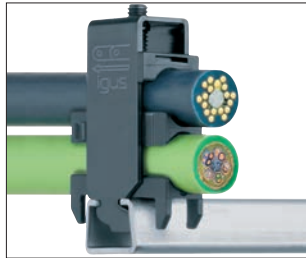

Strain relief e.g. clamps, tie-wrap plates, nugs and plug-in clips ▶ from page 630



Support tray tool kit. For support of the lower run ▶ from page 714

## System E4.1 light - system comparison

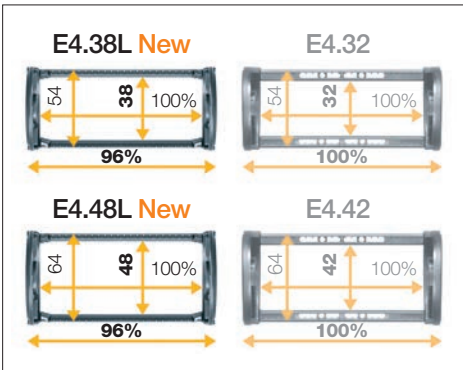

E4.1 light: More inner height at less outer width - save weight, increase capability

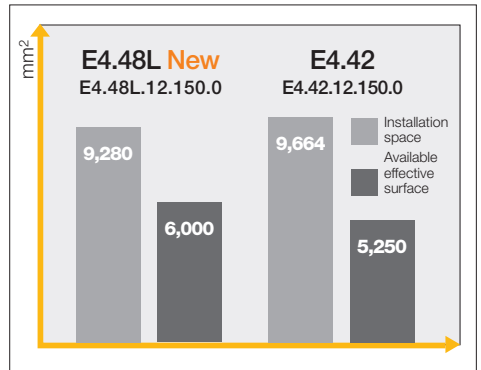

Series E4.48L - More available space with less installation space, compared to Series E4.42

# E4.1 light | Selection Table | Technical Data | Overview

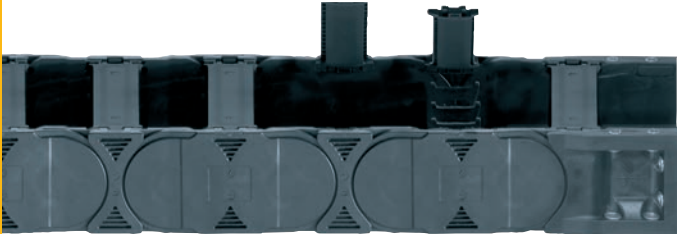
Series	Inner height <i>hi</i> [mm]	Inner width <i>Bi</i> [mm]	Outer width <i>Ba</i> [mm]	Outer height <i>ha</i> [mm]	Bending radius <i>R</i> [mm]	Unsupported max. length [m]	Page
							
<b>E4.38L New*</b>	38	50 - 150	66 - 166	54	150	2,75	426
<b>E4.48L New*</b>	48	50 - 150	70 - 170	64	150	3,75	430

\* in this catalog

## E4.1 light

Crossbars are openable on both sides, and on the inner- and outer radius

## Technical Data



Gliding speed / acceleration (maximum)<sup>1)</sup>

upon request

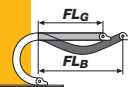

Speed / acceleration  $FL_G$  max.

max. 20 [m/s] / max. 200 [m/s<sup>2</sup>]

Speed / acceleration  $FL_B$  max.

max. 3 [m/s] / max. 6 [m/s<sup>2</sup>]



Material - permitted temperature °C, igumid G / GLW

-40° bis +100° C



Flammability class, igumid G / GLW

VDE 0304 IIC UL94-HB

■  $FL_G$  = with straight upper run ■  $FL_B$  = with permitted sag

<sup>1)</sup> In special cases, gliding applications are also possible, please consult igus\*.









## Installation methods overview, maximum travels

e-chain® Series	Unsupported application	Gliding application	Vertical hanging	Vertical standing	Side mounted unsupported
<b>E4.38 light</b>	≤ 2,75 m	upon request <sup>1)</sup>	≤ 50 m	≤ 3 m	≤ 1,0 m
<b>E4.48 light</b>	≤ 3,75 m	upon request <sup>1)</sup>	≤ 80 m	≤ 3 m	≤ 1,2 m

<sup>1)</sup> In special cases, gliding applications are also possible, please consult igus\*.

# E4.1 light | Order keys and Options

## Options with order keys based on Series E4.38 light

 <b>Standard</b>	Simply turn outer side link without additional work	Reverse bending radius for circular movements	Unsupported lengths +25% possible	ESD / ATEX classified e-chains® 
<b>Part No. Standard</b> 	<b>Part No. NC-Version</b> 	<b>Part No. RBR</b> 	<b>Part No. XXL-Material**</b> 	<b>Part No. ESD-Material</b> 
 <b>E4.38L.12.R.0</b>	<b>E4.38L.12.R.0.NC</b>	<b>E4.38L.12.R1/R2.0</b>	<b>E4.38L.12.R.0.XXL</b> <small>**Sidebands made from XXL-Material</small>	<b>E4.38L.12.R.0.ESD</b>
 <b>Delivery from stock</b>	<b>Delivery time: upon request</b>	<b>Delivery time: upon request</b>	<b>Delivery time: upon request</b>	<b>Delivery time: upon request</b>

## Order example | Order key and color options based on Series E4.38 light

 **Order example for complete e-chain® (1,0 m), color black, with mounting brackets and interior separation:**

<b>e-chain® (1,0 m)</b>	Please indicate e-chain® length or number of links: 1,0 m or 18 links	<b>E4.38L.100.150.0</b>
<b>+ Mounting brackets</b>	KMA - 1 set (with odd number of links and integrated C-profiles)	<b>E4.380.100.2.12.C</b>
<b>+ Interior separation</b>	with 2 separators assembled every 2 <sup>nd</sup> link	<b>2 x 38.1.1</b>







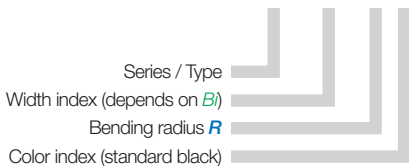



Order text: 1,0 m E4.38L.12.150.0 + E4.380.100.2.12.C + 2 x Art. Nr. 38.1.1

### Order key

e-chain® crossbars every link: **E4.38L.100.150.0**



### General igus® color options for e-chains® and e-tubes

Color	Order index	Color	Order index
 <b>Black</b> Standard, from stock!	<b>.0</b>	 <b>White</b> special color	<b>.1</b>
 <b>Slate grey</b> only ESD material	<b>.ESD</b>	 <b>Gray white</b> special color	<b>.1S</b>
 <b>Gray brown</b> only HT material	<b>.HT</b>	 <b>Orange</b> special color	<b>.2</b>
 <b>Gray</b> special color only e-chains®	<b>.3</b>	 <b>Yellow</b> special color	<b>.4</b>
 <b>Dusty grey</b> special color only e-tubes	<b>.31</b>	 <b>Light grey</b> special color	<b>.14</b>

**Black e-chains® available from stock!**  
Delivery time for special colors: upon request

E4.38L.100.150.0 = with inner width **Bi 100** mm, radius **R 150** mm, color black

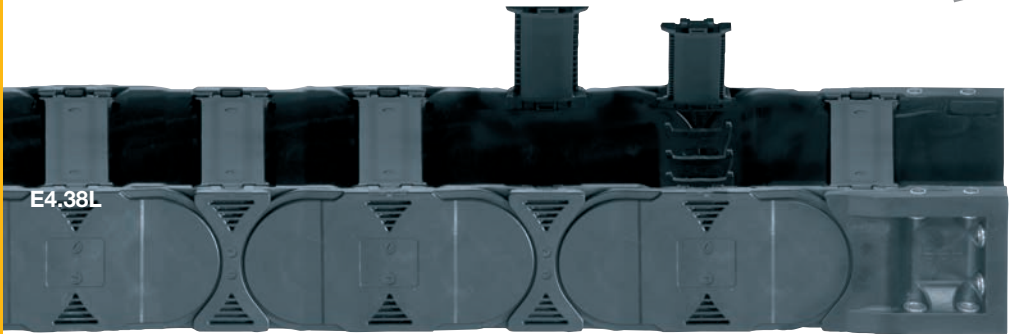

### Series E4.38L | Crossbars are openable on both sides

Part No. e-chains <sup>§</sup>	<i>Bi</i> [mm]	<i>Ba</i> [mm]	E4.38L [kg/m]	Part No. e-chains <sup>§</sup>	<i>Bi</i> [mm]	<i>Ba</i> [mm]	E4.38L [kg/m]
E4.38L.050.R.0	50	66	≈ 1,13	E4.38L.225.R.0**	225	241	≈ 1,97
E4.38L.062.R.0**	62,5	78,5	≈ 1,19	E4.38L.237.R.0**	237,5	253,5	≈ 2,05
E4.38L.075.R.0	75	91	≈ 1,26	E4.38L.250.R.0**	250	266	≈ 2,11
E4.38L.087.R.0**	87,5	103,5	≈ 1,30	E4.38L.262.R.0**	262,5	278,5	≈ 2,15
E4.38L.100.R.0	100	116	≈ 1,37	E4.38L.275.R.0**	275	291	≈ 2,22
E4.38L.105.R.0	105	125	≈ 1,39	E4.38L.287.R.0**	287,5	303,5	≈ 2,30
E4.38L.112.R.0**	112,5	128,5	≈ 1,44	E4.38L.300.R.0**	300	316	≈ 2,36
E4.38L.125.R.0	125	141	≈ 1,50	E4.38L.312.R.0**	312,5	328,5	≈ 2,40
E4.38L.137.R.0**	137,5	153,5	≈ 1,55	E4.38L.325.R.0**	325	341	≈ 2,47
E4.38L.150.R.0	150	166	≈ 1,65	E4.38L.337.R.0**	337,5	353,5	≈ 2,55
E4.38L.162.R.0**	162,5	178,5	≈ 1,69	E4.38L.350.R.0**	350	366	≈ 2,57
E4.38L.175.R.0**	175	191	≈ 1,74	E4.38L.362.R.0**	362,5	378,5	≈ 2,60
E4.38L.187.R.0**	187,5	203,5	≈ 1,80	E4.38L.375.R.0**	375	391	≈ 2,65
E4.38L.200.R.0**	200	216	≈ 1,86	E4.38L.387.R.0**	387,5	403,5	≈ 2,76
E4.38L.212.R.0**	212,5	228,5	≈ 1,90	E4.38L.400.R.0**	400	416	≈ 2,83

\*\*Width available upon request, please consult igus® for delivery time!

\*Radius available upon request, please consult igus® for delivery time!

Available bending radii *R* [mm] 063\* | 075\* | 100\* | 125\* | 150 | 175\* | 200\* | 250\* | 300\* | 350\*

Supplement Part No. with required radius (*R*). Examples:

E4.38L.100.150.0 = e-chain with inner width *Bi* 100 mm, radius *R* 150 mm, color black



Unsupported applications | Short travels

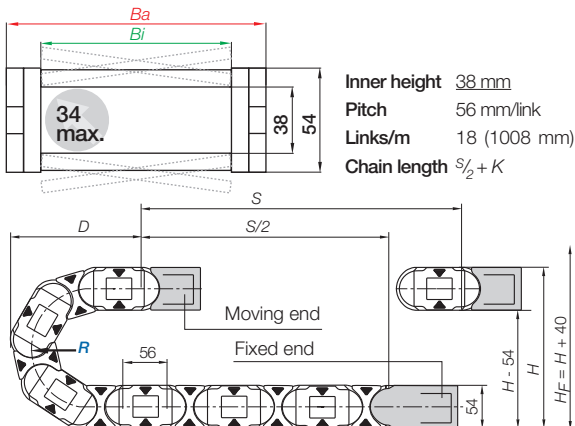
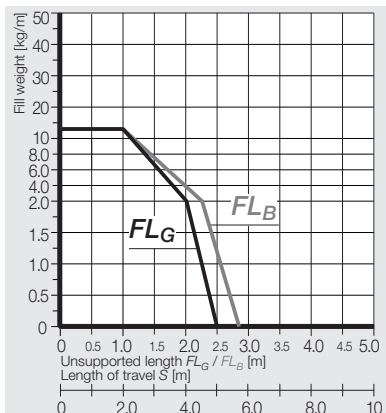

Inner height 38 mm  
 Pitch 56 mm/link  
 Links/m 18 (1008 mm)  
 Chain length  $S/2 + K$

R	063*	075*	100*	125*	150	175*	200*	250*	300*	350*
H	180	204	254	304	354	404	454	554	654	754
D	146	158	183	208	233	258	283	333	383	433
K	310	350	430	505	585	665	745	900	1055	1215

The required clearance height:  $H_F = H + 40$  mm (with 2,0 kg/m fill weight)

\*Radius available upon request, please consult igus\* for delivery time!

**Optional: Support tray tool kit.**

**For support of the lower run.**

Simple one-piece support trays according to your requirements and specification.

The complete range with order options ▶ from page 714



# E4.1 light | Series E4.38L | Accessories

## KMA mounting brackets | Attachment on all sides | pivoting

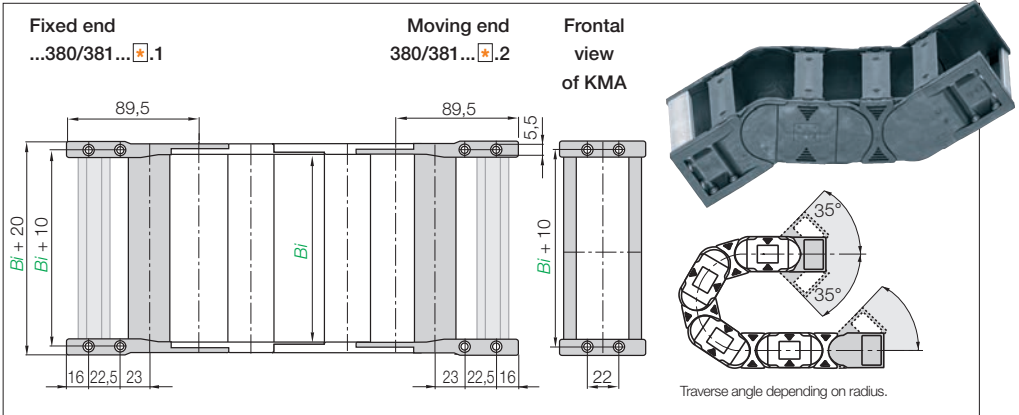

**KMA pivoting** | Standard | Recommended for unsupported and gliding applications<sup>1)</sup>  
**KMA locking** | Recommended for vertical hanging and standing applications

Width Index	Standard	Part No. full set KMA pivoting:	Part No. full set KMA locking:	Bi [mm]	Width Index	Standard	Part No. full set KMA pivoting:	Part No. full set KMA locking:	Bi [mm]
050.	▶	E4.380.050 [1].12.C	E4.381.050 [1].12.C	50	225.	▶	E4.380.225 [1].12.C*	E4.381.225 [1].12.C*	225
062.	▶	E4.380.062 [1].12.C*	E4.381.062 [1].12.C*	62,5	237.	▶	E4.380.237 [1].12.C*	E4.381.237 [1].12.C*	237,5
075.	▶	E4.380.075 [1].12.C	E4.381.075 [1].12.C	75	250.	▶	E4.380.250 [1].12.C*	E4.381.250 [1].12.C*	250
087.	▶	E4.380.087 [1].12.C*	E4.381.087 [1].12.C*	87,5	262.	▶	E4.380.262 [1].12.C*	E4.381.262 [1].12.C*	262,5
100.	▶	E4.380.100 [1].12.C	E4.381.100 [1].12.C	100	275.	▶	E4.380.275 [1].12.C*	E4.381.275 [1].12.C*	275
105.	▶	E4.380.105 [1].12.C	E4.381.105 [1].12.C	105	287.	▶	E4.380.287 [1].12.C*	E4.381.287 [1].12.C*	287,5
112.	▶	E4.380.112 [1].12.C*	E4.381.112 [1].12.C*	112,5	300.	▶	E4.380.300 [1].12.C*	E4.381.300 [1].12.C*	300
125.	▶	E4.380.125 [1].12.C	E4.381.125 [1].12.C	125	312.	▶	E4.380.312 [1].12.C*	E4.381.312 [1].12.C*	312,5
137.	▶	E4.380.137 [1].12.C*	E4.381.137 [1].12.C*	137,5	325.	▶	E4.380.325 [1].12.C*	E4.381.325 [1].12.C*	325
150.	▶	E4.380.150 [1].12.C	E4.381.150 [1].12.C	150	337.	▶	E4.380.337 [1].12.C*	E4.381.337 [1].12.C*	337,5
162.	▶	E4.380.162 [1].12.C*	E4.381.162 [1].12.C*	162,5	350.	▶	E4.380.350 [1].12.C*	E4.381.350 [1].12.C*	350
175.	▶	E4.380.175 [1].12.C*	E4.381.175 [1].12.C*	175	362.	▶	E4.380.362 [1].12.C*	E4.381.362 [1].12.C*	362,5
187.	▶	E4.380.187 [1].12.C*	E4.381.187 [1].12.C*	187,5	375.	▶	E4.380.375 [1].12.C*	E4.381.375 [1].12.C*	375
200.	▶	E4.380.200 [1].12.C*	E4.381.200 [1].12.C*	200	387.	▶	E4.380.387 [1].12.C*	E4.381.387 [1].12.C*	387,5
212.	▶	E4.380.212 [1].12.C*	E4.381.212 [1].12.C*	212,5	400.	▶	E4.380.400 [1].12.C*	E4.381.400 [1].12.C*	400

(KMA = Polymer Metal Mounting Bracket) <sup>1)</sup> Please consult igus\* for gliding applications

\*Width available upon request, please consult igus\* for delivery time!

**Note\*:** The E4.1 may end with either an inner or an outer side link. An outer side link always forms the first e-chain® link at the moving end. The Part No. depend on an even or odd numbers of links. Please insert: Index [1] (for odd) or [2] (for even). For the **preassembled** mode please add index **A**.

**E4.380.100 [2].12.C A** Part No. structure

- A... must be indicated on preassembled configurations
- C-profile option
- Full set
- Even numbers of links
- Width index
- Series

**Strain relief** e.g. clamps, tiewrap plates, nuggets and plug-in clips are available from stock. The complete chainfix range with order options ▶ from page 630

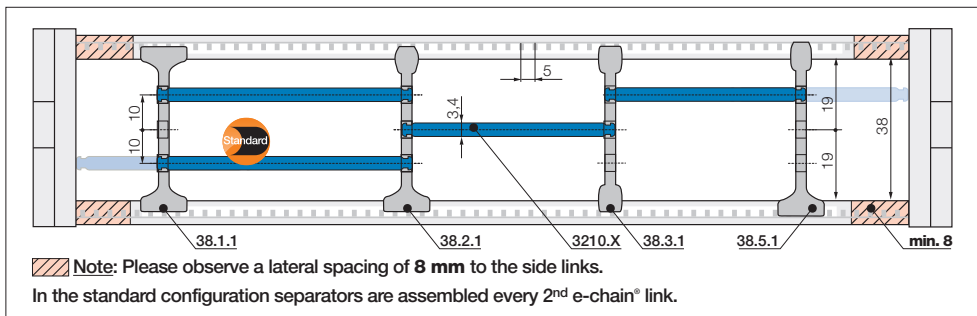

**Standard separator, wide base**  
unassembled **38.1**  
assembled **38.1.1**

**Standard - for all applications**  
Separator with a wide base for maximum locking strength and safe standing in e-chains® and e-tubes.

**Separator, narrow head**  
unassembled **38.2**  
assembled **38.2.1**

**For even faster installation**  
Firm hold to one side with a wide base, narrow on opposed side for easy cable assembly (slight grip).

**Separator, narrow base**  
unassembled **38.3**  
assembled **38.3.1**

**For many thin cables**  
Separator with a narrow base for a large number of thin cables side by side. Saves space in e-chains®.

**Notch separator for notch crossbar**  
unassembled **38.5**  
assembled **38.5.1**

**Locks safely in 5 mm increments**  
Notch separator for the new notch crossbar, with scaling on the notch crossbars. For exact positioning in e-chains®. Recommended for side-mounted applications.

**Full-width shelf, lockable**  
unassembled **3200.X**  
assembled **3210.X**

**Horizontal separation**  
Shelf locks safely into separators on both ends, fixed width possible. Separators can be moved freely over the shelf in horizontal direction. Can be arranged at 3 different heights.

**Lockable full-width shelves**



Width X [mm]	unassembled	assembled	Width X [mm]	unassembled	assembled	Width X [mm]	unassembled	assembled
050	3200.050	3210.050	125	3200.125	3210.125	225	3200.225	3210.225
075	3200.075	3210.075	150	3200.150	3210.150	250	3200.250	3210.250
100	3200.100	3210.100	175	3200.175	3210.175			
115	3200.115	3210.115	200	3200.200	3210.200			

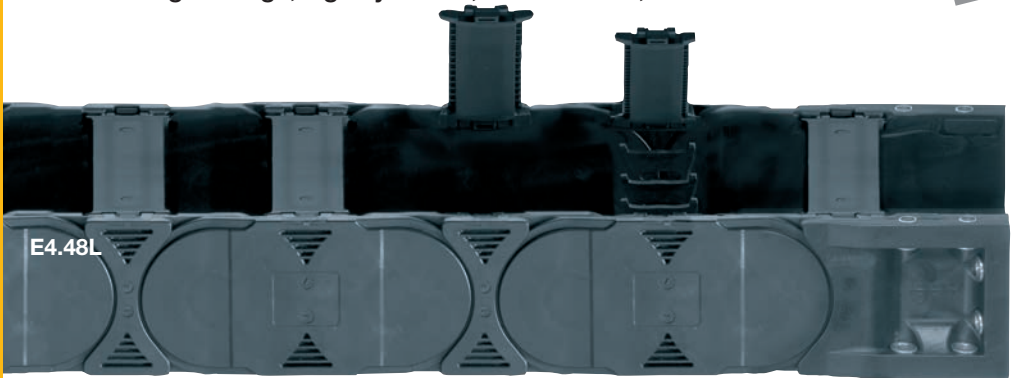

E4.48L

## Series E4.48L | Crossbars are openable on both sides

Part No. e-chains <sup>g</sup>	<i>Bi</i> [mm]	<i>Ba</i> [mm]	E4.48L [kg/m]	Part No. e-chains <sup>g</sup>	<i>Bi</i> [mm]	<i>Ba</i> [mm]	E4.48L [kg/m]
E4.48L.050.R.0	50	70	≈ 1,53	E4.48L.225.R.0**	225	245	≈ 2,24
E4.48L.062.R.0**	62,5	82,5	≈ 1,58	E4.48L.237.R.0**	237,5	257,5	≈ 2,30
E4.48L.075.R.0	75	95	≈ 1,64	E4.48L.250.R.0**	250	270	≈ 2,35
E4.48L.087.R.0**	87,5	107,5	≈ 1,67	E4.48L.262.R.0**	262,5	282,5	≈ 2,39
E4.48L.100.R.0	100	120	≈ 1,73	E4.48L.275.R.0**	275	295	≈ 2,45
E4.48L.105.R.0	105	125	≈ 1,74	E4.48L.287.R.0**	287,5	307,5	≈ 2,51
E4.48L.112.R.0**	112,5	132,5	≈ 1,79	E4.48L.300.R.0**	300	320	≈ 2,56
E4.48L.125.R.0	125	145	≈ 1,84	E4.48L.312.R.0**	312,5	332,5	≈ 2,60
E4.48L.137.R.0**	137,5	157,5	≈ 1,88	E4.48L.325.R.0**	325	345	≈ 2,66
E4.48L.150.R.0	150	170	≈ 1,97	E4.48L.337.R.0**	337,5	357,5	≈ 2,72
E4.48L.162.R.0**	162,5	182,5	≈ 2,00	E4.48L.350.R.0**	350	370	≈ 2,74
E4.48L.175.R.0**	175	195	≈ 2,04	E4.48L.362.R.0**	362,5	382,5	≈ 2,77
E4.48L.187.R.0**	187,5	207,5	≈ 2,09	E4.48L.375.R.0**	375	395	≈ 2,81
E4.48L.200.R.0**	200	220	≈ 2,14	E4.48L.387.R.0**	387,5	407,5	≈ 2,90
E4.48L.212.R.0**	212,5	232,5	≈ 2,18	E4.48L.400.R.0**	400	420	≈ 2,96

\*\*Width available upon request, please consult igus<sup>®</sup> for delivery time!\*Radius available upon request, please consult igus<sup>®</sup> for delivery time!Available bending radii *R* [mm] 075\* | 100\* | 125\* | 150 | 175\* | 200\* | 250\* | 300\* | 350\* |Supplement Part No. with required radius (*R*). Examples:E4.48L.100.150.0 = e-chain with inner width *Bi* 100 mm, radius *R* 150 mm, color black





Unsupported applications | Short travels

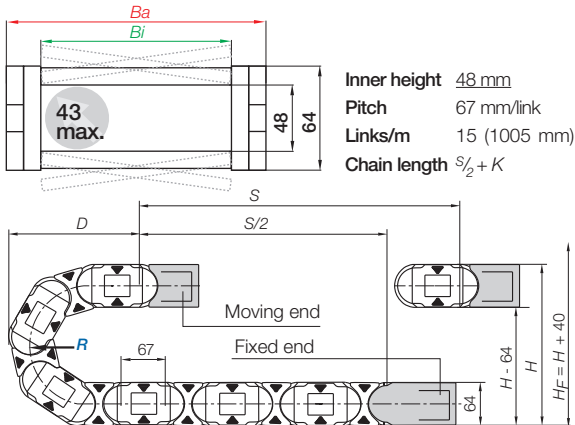
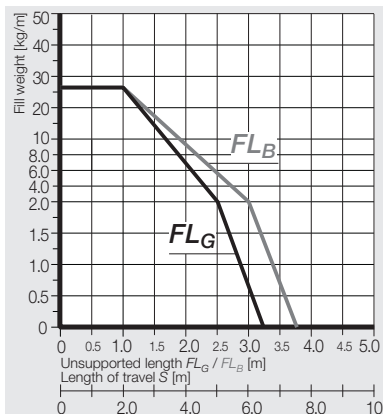

Inner height 48 mm  
 Pitch 67 mm/link  
 Links/m 15 (1005 mm)  
 Chain length  $\frac{S}{2} + K$

	075*	100*	125*	150	175*	200*	250*	300*	350*
<b>R</b>	214	264	314	364	414	464	564	664	764
<b>H</b>	208	233	258	283	308	333	383	433	483
<b>D</b>	370	450	530	610	685	765	920	1080	1235

The required clearance height:  $H_F = H + 40$  mm (with 2,5 kg/m fill weight)

\*Radius available upon request, please consult igus\* for delivery time!

**Optional: Support tray tool kit.**

**For support of the lower run.**

Simple one-piece support trays according to your requirements and specification.

The complete range with order options ► from page 714

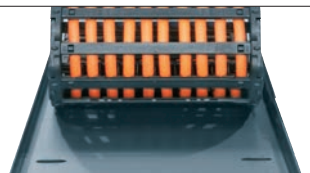

# E4.1 light | Series E4.48L | Accessories

## KMA mounting brackets | Attachment on all sides | pivoting

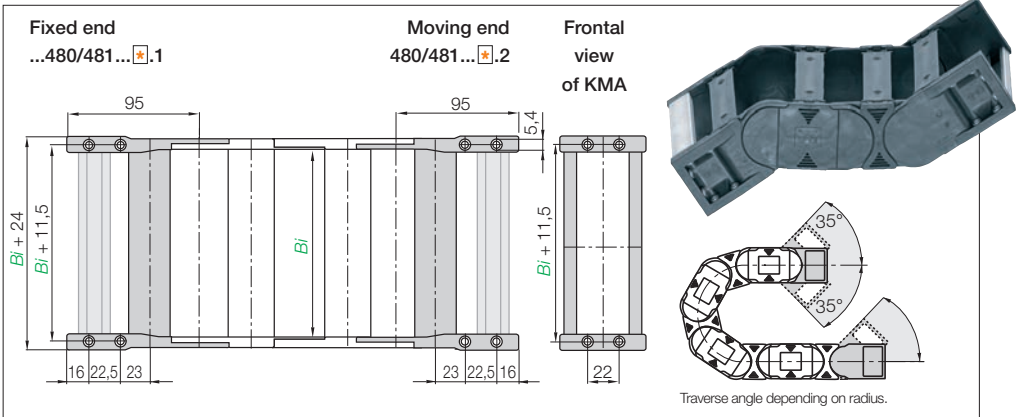

**KMA pivoting** | Standard | Recommended for unsupported and gliding applications<sup>1)</sup>  
**KMA locking** | Recommended for vertical hanging and standing applications

Width Index	Standard	Part No. full set KMA pivoting:	Part No. full set KMA locking:	Bi [mm]	Width Index	Standard	Part No. full set KMA pivoting:	Part No. full set KMA locking:	Bi [mm]
050.	▶	E4.480.050 [1].12.C	E4.481.050 [2].12.C	50	225.	▶	E4.480.225 [1].12.C*	E4.481.225 [2].12.C*	225
062.	▶	E4.480.062 [1].12.C*	E4.481.062 [2].12.C*	62,5	237.	▶	E4.480.237 [1].12.C*	E4.481.237 [2].12.C*	237,5
075.	▶	E4.480.075 [1].12.C	E4.481.075 [2].12.C	75	250.	▶	E4.480.250 [1].12.C*	E4.481.250 [2].12.C*	250
087.	▶	E4.480.087 [1].12.C*	E4.481.087 [2].12.C*	87,5	262.	▶	E4.480.262 [1].12.C*	E4.481.262 [2].12.C*	262,5
100.	▶	E4.480.100 [1].12.C	E4.481.100 [2].12.C	100	275.	▶	E4.480.275 [1].12.C*	E4.481.275 [2].12.C*	275
105.	▶	E4.480.105 [1].12.C	E4.481.105 [2].12.C	105	287.	▶	E4.480.287 [1].12.C*	E4.481.287 [2].12.C*	287,5
112.	▶	E4.480.112 [1].12.C*	E4.481.112 [2].12.C*	112,5	300.	▶	E4.480.300 [1].12.C*	E4.481.300 [2].12.C*	300
125.	▶	E4.480.125 [1].12.C	E4.481.125 [2].12.C	125	312.	▶	E4.480.312 [1].12.C*	E4.481.312 [2].12.C*	312,5
137.	▶	E4.480.137 [1].12.C*	E4.481.137 [2].12.C*	137,5	325.	▶	E4.480.325 [1].12.C*	E4.481.325 [2].12.C*	325
150.	▶	E4.480.150 [1].12.C	E4.481.150 [2].12.C	150	337.	▶	E4.480.337 [1].12.C*	E4.481.337 [2].12.C*	337,5
162.	▶	E4.480.162 [1].12.C*	E4.481.162 [2].12.C*	162,5	350.	▶	E4.480.350 [1].12.C*	E4.481.350 [2].12.C*	350
175.	▶	E4.480.175 [1].12.C*	E4.481.175 [2].12.C*	175	362.	▶	E4.480.362 [1].12.C*	E4.481.362 [2].12.C*	362,5
187.	▶	E4.480.187 [1].12.C*	E4.481.187 [2].12.C*	187,5	375.	▶	E4.480.375 [1].12.C*	E4.481.375 [2].12.C*	375
200.	▶	E4.480.200 [1].12.C*	E4.481.200 [2].12.C*	200	387.	▶	E4.480.387 [1].12.C*	E4.481.387 [2].12.C*	387,5
212.	▶	E4.480.212 [1].12.C*	E4.481.212 [2].12.C*	212,5	400.	▶	E4.480.400 [1].12.C*	E4.481.400 [2].12.C*	400

(KMA = Polymer Metal Mounting Bracket) 1) Please consult igus\* for gliding applications

\*Width available upon request, please consult igus\* for delivery time!

**Note\*:** The E4.1 may end with either an inner or an outer side link. An outer side link always forms the first e-chain® link at the moving end. The Part No. depend on an even or odd numbers of links. Please insert: Index [1] (for odd) or [2] (for even). For the **preassembled** mode please add index **A**.

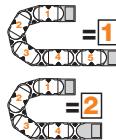

**E4.480.100 [2].12.C A** Part No. structure

- A... must be indicated on preassembled configurations
- C-profile option
- Full set
- Even numbers of links
- Width index
- Series

**Strain relief** e.g. clamps, tiewrap plates, nuggets and plug-in clips are available from stock. The complete chainfix range with order options ▶ from page 630

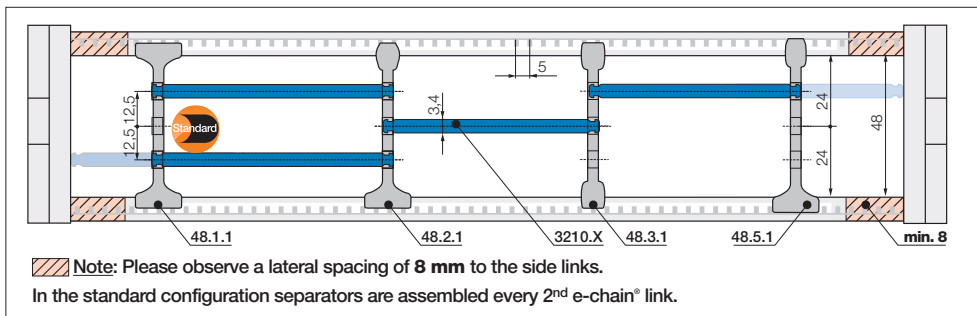

**Standard separator, wide base**

unassembled	<b>48.1</b>
assembled	<b>48.1.1</b>

**Standard - for all applications**

Separator with a wide base for maximum locking strength and safe standing in e-chains® and e-tubes.

**Separator, narrow head**

unassembled	<b>48.2</b>
assembled	<b>48.2.1</b>

**For even faster installation**

Firm hold to one side with a wide base, narrow on opposed side for easy cable assembly (slight grip).

**Separator, narrow base**

unassembled	<b>48.3</b>
assembled	<b>48.3.1</b>

**For many thin cables**

Separator with a narrow base for a large number of thin cables side by side. Saves space in e-chains®.

**Notch separator for notch crossbar**

unassembled	<b>48.5</b>
assembled	<b>48.5.1</b>

**Locks safely in 5 mm increments**

Notch separator for the new notch crossbar, with scaling on the notch crossbars. For exact positioning in e-chains®. Recommended for side-mounted applications.

**Full-width shelf, lockable**

unassembled	<b>3200.X</b>
assembled	<b>3210.X</b>

**Horizontal separation**

Shelf locks safely into separators on both ends, fixed width possible. Separators can be moved freely over the shelf in horizontal direction. Can be arranged at 3 different heights.

**Lockable full-width shelves**



Width X [mm]	unassembled	assembled	Width X [mm]	unassembled	assembled	Width X [mm]	unassembled	assembled
050	3200.050	3210.050	125	3200.125	3210.125	225	3200.225	3210.225
075	3200.075	3210.075	150	3200.150	3210.150	250	3200.250	3210.250
100	3200.100	3210.100	175	3200.175	3210.175			
115	3200.115	3210.115	200	3200.200	3210.200			

## E4/light - light, stable and cost-effective

E4/light - Weight reduction, a large interior space and price reduction result in high strength. The "light" features appear in two places: A reduced thickness of the side links (for all types), and a thinner crossbar (for some types: 14240, 14340). E4/light e-chains® achieve optimum price-performance solutions for many industries. Especially for unsupported short travels, hanging and short standing designs. E4/light types are often first choice.

### Typical industries and applications

- Machine tools
- Material handling
- Stone cutting machines
- Woodworking machines
- General machinery
- Vehicles
- Construction machinery
- Limited long travel applications

Universal: Attachment on all sides

Low noise: Optional dampening pads

Chip protection: Openable lids

Long lifetime: Gliding surfaces for long travels

High stability: "Undercut" design, high strengths and loads

25% faster: Easy assembly with QuickLock-crossbars

No camber: No rework due to special design principle

Precise dividing: Notch crossbar with visual scale

Low noise operation: Due to integrated "brakes"



Electrically conductive ESD/ATEX versions several Series available from stock



Side-mounted - unsupported



High torsional rigidity



System E4 - 4-piece design link

# E4/light | Features | Accessories



"Undercut" design, for high strengths and high loads



E4/light - High stability also for side-mounted applications



Crossbars openable on both sides



Easy to open with screwdriver

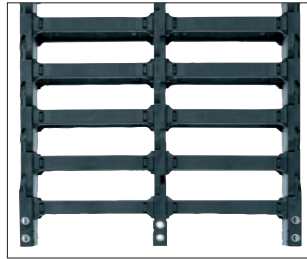

The extension link design allows virtually limitless side-by-side attachment

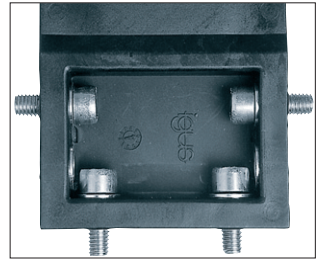

KMA mounting brackets with attachment options on all sides

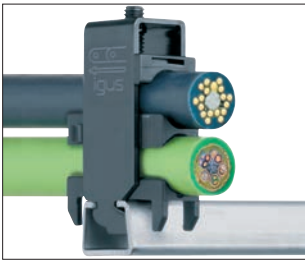

Strain relief e.g. clamps, tiwrap plates, nugs and plug-in clips ► from page 630



Guide troughs - "Super Aluminum Trough" Basic and Heavy-Duty ► from page 664



Support tray tool kit. For support of the lower run ► from page 714

# E4/light | Selection Table

Series	Inner height <i>hi</i> [mm]	Inner width <i>Bi</i> [mm]	Outer width <i>Ba</i> [mm]	Outer height <i>ha</i> [mm]	Bending radius <i>R</i> [mm]	Unsupported max. length. [m]	page
--------	--------------------------------	-------------------------------	-------------------------------	--------------------------------	---------------------------------	---------------------------------	------



## Crossbars every link

e-chains® for particularly demanding applications

14040	56	50 - 600	76 - 626	84	135 - 500	4,0	440
14240	62	50 - 400	76 - 426	84	135 - 500	4,0	446
14550	70	50 - 600	77 - 627	98	150 - 600	4,2	452
15050	80	50 - 600	80 - 630	108	150 - 600	4,6	458
15250	86	50 - 400	80 - 430	108	150 - 600	4,6	464
1640	112	50 - 600	84 - 634	140	200 - 600	4,50	470



## Crossbars every 2<sup>nd</sup> link

e-chains® for almost all applications - Standard

14140	56	50 - 600	76 - 626	84	135 - 500	4,0	440
14340	62	50 - 400	76 - 426	84	135 - 500	4,0	446
14650	70	50 - 600	77 - 627	98	150 - 600	4,2	452
15150	80	50 - 600	80 - 630	108	150 - 600	4,6	458
15350	86	50 - 400	80 - 430	108	150 - 600	4,6	464



## e-tubes

fully enclosed,  
excellent cable protection

R18840	56	75 - 462	101 - 489	84	150 - 500	4,0	440
R19050	70	75 - 462	102 - 489	98	200 - 600	4,2	452
R19850	80	75 - 462	105 - 493	108	200 - 500	4,6	458
R1608	108	200 - 400	234 - 434	140	250 - 600	4,50	470

## Technical Data



Gliding speed / acceleration (maximum) max. 5 [m/s] / max. 50 [m/s<sup>2</sup>]



Speed / acceleration  $FL_G$  max. max. 20 [m/s] / max. 200 [m/s<sup>2</sup>]

Speed / acceleration  $FL_B$  max. max. 3 [m/s] / max. 6 [m/s<sup>2</sup>]











Material - permitted temperature °C, igumid G / GLW -40° up to +100° C



Flammability class, igumid G / GLW VDE 0304 IIC UL94-HB







■  $FL_G$  = with straight upper run ■  $FL_B$  = with permitted sag

## Installation methods overview, maximum travels

e-chain® / e-tube Series	 Unsupported application	 Gliding application	 Vertical hanging	 Vertical standing	 Side mounted unsupported	 Rotary application	 Zig-zag application	 Unsupp. length of lower run
14040/14140/R18840	≤ 4,0 m	≤ 150 m	≤ 80 m	≤ 6,0 m	≤ 2,0 m	with rework	upon request	upon request
14240/14340	≤ 4,0 m	≤ 150 m	≤ 80 m	≤ 6,0 m	≤ 2,0 m	with rework	upon request	upon request
14550/14650/R19050	≤ 4,2 m	≤ 250 m	≤ 90 m	≤ 6,0 m	≤ 2,0 m	with rework	upon request	upon request
15050/15150/R19850	≤ 4,6 m	≤ 250 m	≤ 100 m	≤ 6,0 m	≤ 2,0 m	with rework	upon request	upon request
15250/15350	≤ 4,6 m	≤ 250 m	≤ 100 m	≤ 6,0 m	≤ 2,0 m	with rework	upon request	upon request
1640/R1608	≤ 4,5 m	≤ 400 m	≤ 100 m	≤ 5,0 m	≤ 2,0 m	with rework	upon request	upon request

# E4/light | Order keys and Options

## Options with order keys | based on Series 14040/14140/18840

	<i>Standard</i>	<i>Additional noise dampening with pads</i>	<i>QuickLock crossbar - reduce assembly time up to 25%</i>		
<b>Part No.</b> Standard e-chains®/e-tubes	<b>Part No.</b> Low noise (with pads) e-chains®/e-tubes	<b>Part No.</b> QuickLock crossbar for inner radius	<b>Part No.</b> QuickLock crossbar for outer radius	<b>Part No.</b> QuickLock crossbar for both radii	
			QuickLock crossbars: inner widths from Bi 15 (150 mm)		
	<b>14040.30.R.0</b> Crossbar every link	<b>ES4.56.30.R.0</b> Crossbar every link	<b>14040.30QZ.R.0</b> Crossbar every link	<b>14040.30QE.R.0</b> Crossbar every link	<b>14040.30Q.R.0</b> Crossbar every link
	<b>14140.30.R.0</b> Crossbar every 2 <sup>nd</sup> link	<b>HS4.56.30.R.0</b> Crossbar every 2 <sup>nd</sup> link	<b>14140.30QZ.R.0</b> Crossbar every 2 <sup>nd</sup> link	<b>14140.30QE.R.0</b> Crossbar every 2 <sup>nd</sup> link	<b>14140.30Q.R.0</b> Crossbar every 2 <sup>nd</sup> link
	<b>18840.30.R.0</b> e-tube, closed	<b>RS4.56.30.R.0</b> e-tube, closed			
	<b>Delivery from stock</b>	<b>Delivery time: upon request</b>	<b>Delivery time: upon request</b>	<b>Delivery time: upon request</b>	<b>Delivery time: upon request</b>

## Order example | based on Series 14040/14140/18840

 Order example for complete e-chain® (3,0 m, with crossbars every link), color black, mounting brackets and interior separation

e-chain® (3,0 m)	Please indicate e-chain® length or number of links: 3,0 m or 33 links	<b>14040.30.300.0</b>
+ Mounting brackets	KMA - 1 set (with integrated C-profiles)	<b>140400.30.1.12.C</b>
+ Interior separation	with 2 separators assembled every 2 <sup>nd</sup> link	<b>2 x 56.1.1</b>

Order text: 3,0 m 14040.30.300.0 + 140400.30.1.12.C + 2 x Part No. 56.1.1



# E4/light | Order keys and Options

Simply turn outer side link without additional work

Reverse bending radius for circular movements

Unsupported lengths +25% possible

No burning-in of hot chips up to 850°C (1562°F)

ESD / ATEX classified e-chains®  

Part No.  
**NC-Version**  
 e-chains®/e-tubes

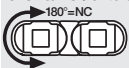

Part No.  
**RBR**  
 e-chains®/e-tubes



Part No.  
**XXL-Material\*\***  
 e-chains®/e-tubes



Part No.  
**igumid HT-Material**  
 only for e-tubes



Part No.  
**ESD-Material**  
 e-chains®/e-tubes



**14040.30.R.0.NC**

Crossbar every link

**14040.30.R1/R2.0**

Crossbar every link

**14040.30.R.0.XXL**

Crossbar every link

**18840.30.R.0.HT**

Complete e-tube\*

**14040.30.R.0.ESD**

Crossbar every link

**14140.30.R.0.NC**

Crossbar every 2<sup>nd</sup> link

**14140.30.R1/R2.0**

Crossbar every 2<sup>nd</sup> link

**14140.30.R.0.XXL**

Crossbar every 2<sup>nd</sup> link

**18840.30.HT.R.0**

Lid and bottom

**14140.30.R.0.ESD**

Crossbar every 2<sup>nd</sup> link

**18840.30.R.0.NC**

e-tube, closed

**18840.30.R1/R2.0**

e-tube, closed

**18840.30.R.0.XXL**

e-tube, closed

**18840.30.HTZ.R.0**

Bottom only

**18840.30.R.0.ESD**

e-tube, closed

**18840.30.HTE.R.0**

Lid only

**Delivery time:**  
 upon request

**Delivery time:**  
 upon request

**Delivery time:**  
 upon request

**Delivery time:**  
 upon request

**Delivery time:**  
 Several series  
 from stock

\*\*Sidebands made from  
 XXL-Material

\*for gliding applications  
 please consult igus®

## Order key and color options | based on Series 14040/14140/18840



### Order key

e-chain® crossbars every link **14040.30.300.0**  
 e-chain® crossbars every 2<sup>nd</sup> link **14140.30.300.0**  
 e-tube fully enclosed **18840.30.300.0**

Series / Type  
 Width index (depends on *Bi*)  
 Bending radius *R*  
 Color index (standard black)



### General igus® color options for e-chains® and e-tubes

Color	Order index	Color	Order index
<b>Black</b> Standard, from stock!	<b>.0</b>	<b>White</b> special color	<b>.1</b>
<b>Slate grey</b> only ESD material	<b>.ESD</b>	<b>Gray white</b> special color	<b>.1S</b>
<b>Gray brown</b> only HT material	<b>.HT</b>	<b>Orange</b> special color	<b>.2</b>
<b>Gray</b> special color only e-chains®	<b>.3</b>	<b>Yellow</b> special color	<b>.4</b>
<b>Dusty grey</b> special color only e-tubes	<b>.31</b>	<b>Light grey</b> special color	<b>.14</b>

**Black e-chains® available from stock!**

**Delivery time for special colors: upon request**

**14040.30.300.0** = e-chain® with crossbars every link, inner width *Bi* 300 mm, radius *R* 300 mm, color black

**14140.30.300.0** = e-chain® with crossbars every 2<sup>nd</sup> link, inner width *Bi* 300 mm, radius *R* 300 mm, color black

**18840.30.300.0** = e-tube fully enclosed, inner width *Bi* 300 mm, radius *R* 300 mm, color black



e-chains® | Series 14040 crossbars every link (crossbars removable along both radii)

e-chains® | Series 14140 crossbars every 2<sup>nd</sup> link (crossbars removable along both radii)

e-tubes | Series R18840 fully enclosed (hinged snap-open removable lids along outer radius)

Part No. e-chains® / e-tubes	Bi [mm]	Ba [mm]	14040 [kg/m]	14140 [kg/m]	18840 [kg/m]	
14040.14140. -	05. R.0	50	76	≈ 2,66	≈ 2,48	-
14040.14140. -	06. R.0	65	91	≈ 2,47	≈ 2,51	-
14040.14140.18840. <sup>1)</sup>	07. R.0	75	101	≈ 2,75	≈ 2,25	≈ 3,20
14040.14140. -	08. R.0	87	113	≈ 2,84	≈ 2,44	-
14040.14140.18840.	10. R.0	100	126	≈ 2,93	≈ 2,61	≈ 3,49
14040.14140. -	11. R.0	112	139	≈ 3,06	≈ 2,67	-
14040.14140.18840.	12. R.0	125	151	≈ 3,12	≈ 2,71	≈ 3,85
14040.14140. -	13. R.0	137	164	≈ 3,26	≈ 2,77	-
14040.14140.18840.	15. R.0	150	176	≈ 3,32	≈ 2,81	≈ 4,28
14040.14140. -	16. R.0	162	189	≈ 3,43	≈ 2,86	-
14040.14140.18840.	17. R.0	175	201	≈ 3,54	≈ 2,92	≈ 4,54
14040.14140. -	18. R.0	187	214	≈ 3,65	≈ 2,97	-
14040.14140.18840.	20. R.0	200	226	≈ 3,67	≈ 2,98	≈ 4,85
14040.14140. -	21. R.0	212	239	≈ 3,78	≈ 3,04	-
14040.14140. -	22. R.0	225	251	≈ 3,85	≈ 3,07	-
14040.14140. -	23. R.0	237	264	≈ 3,98	≈ 3,14	-
14040.14140.18840.	25. R.0	250	276	≈ 4,07	≈ 3,18	≈ 5,58
14040.14140. -	26. R.0	262	289	≈ 4,16	≈ 3,22	-
14040.14140.18840.	27. R.0	275	301	≈ 4,27	≈ 3,28	≈ 5,85
14040.14140. -	28. R.0	287	314	≈ 4,29	≈ 3,29	-
14040.14140.18840.	30. R.0	300	326	≈ 4,51	≈ 3,40	≈ 6,24

Part No. e-chains® / e-tubes	Bi [mm]	Ba [mm]	14040 [kg/m]	14140 [kg/m]	18840 [kg/m]	
14040.14140. -	31. R.0	312	339	≈ 4,57	≈ 3,42	-
14040.14140. -	32. R.0	325	351	≈ 4,60	≈ 3,44	-
14040.14140. -	33. R.0	337	364	≈ 4,77	≈ 3,53	-
14040.14140.18840.	35. R.0	350	376	≈ 4,93	≈ 3,61	≈ 6,99
14040.14140. -	36. R.0	362	389	≈ 4,94	≈ 3,61	-
14040.14140. -	37. R.0	375	401	≈ 4,95	≈ 3,62	-
14040.14140. -	38. R.0	387	414	≈ 5,04	≈ 3,66	-
14040.14140.18840.	40. R.0	400	426	≈ 5,24	≈ 3,76	≈ 7,94
14040.14140. -	41. R.0	412	439	≈ 5,39	≈ 3,84	-
14040.14140. -	42. R.0	425	451	≈ 5,54	≈ 3,92	-
14040.14140. -	43. R.0	437	464	≈ 5,61	≈ 3,95	-
14040.14140. -	45. R.0	450	476	≈ 5,68	≈ 3,98	-
14040.14140.18840.	46. R.0	462	489	≈ 5,70	≈ 3,99	≈ 8,40
14040.14140. -	47. R.0	475	501	≈ 5,83	≈ 4,06	-
14040.14140. -	48. R.0	487	514	≈ 5,86	≈ 4,08	-
14040.14140. -	50. R.0	500	526	≈ 5,96	≈ 4,13	-
14040.14140. -	51. R.0	512	539	≈ 5,98	≈ 4,14	-
14040.14140. -	52. R.0	525	551	≈ 6,03	≈ 4,16	-
14040.14140. -	53. R.0	537	564	≈ 6,18	≈ 4,24	-
14040.14140. -	55. R.0	550	576	≈ 6,67	≈ 4,48	-
14040.14140. -	60. R.0	600	626	≈ 6,98	≈ 4,58	-

\*Radius not available for e-tubes <sup>1)</sup> Removable lid only, no hinged option

Available bending radii *R* [mm] 135\* | 150 | 175 | 200 | 250 | 300 | 400 | 500

Supplement Part No. with required radius (*R*). Examples:

14040.30.300.0 = e-chain® with crossbars every link, inner width *Bi* 300 mm, radius *R* 300 mm, color black

14140.30.300.0 = e-chain® with crossbars every 2<sup>nd</sup> link, inner width *Bi* 300 mm, radius *R* 300 mm, color black

18840.30.300.0 = e-tube fully enclosed, inner width *Bi* 300 mm, radius *R* 300 mm, color black



## Unsupported applications | Short travels

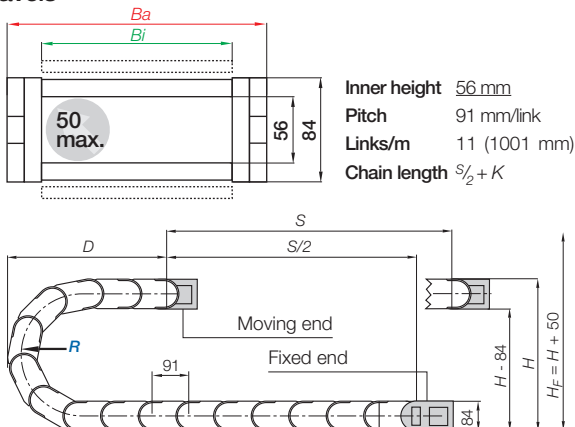
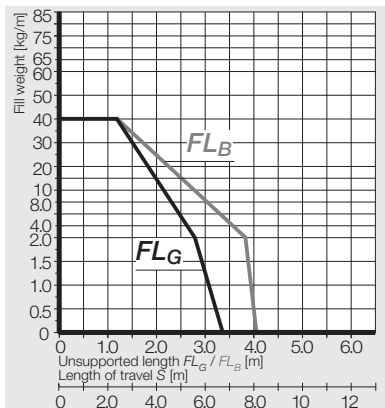

R	135	150	175	200	250	300	400	500
$H_{+25}^0$	354	384	434	484	584	684	884	1084
D	314	329	354	379	429	479	579	679
K	610	655	735	815	970	1125	1440	1755

The required clearance height:  $H_F = H + 50$  mm (with 2,0 kg/m fill weight)

\*Radius not available for e-tubes

## Gliding applications | Long travels from 12 m to max. 150 m

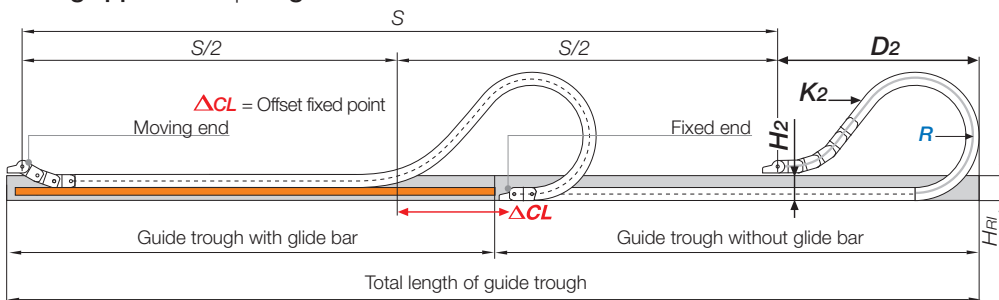

**Note:** For for long travel applications with more than 100 m we recommend to realize the engineering of such a plant by our technicians. In case of travels between 8 and 12 m we recommend a longer unsupported length. **Chain length**  $S/2 + K_2$

R	135*	150	175	200	250	300	400	500
$H_2$	266	266	266	266	266	266	266	266
$D_2^{+25}$	390	450	530	710	920	1120	1530	1830
$K_2$	728	819	1001	1274	1638	1911	2548	3185
$\Delta CL$	124	159	209	359	509	659	959	1159

\*Radius not available for e-tubes

# E4/light | 14040·14140·R18840 | Accessories

KMA mounting brackets | Attachment on all sides | pivoting | locking

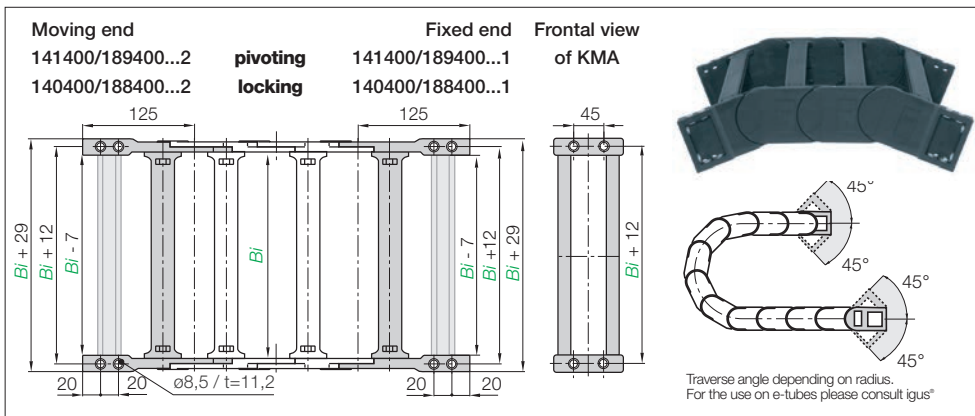

**KMA pivoting** | Standard | Recommended for unsupported and gliding applications  
**KMA locking** | Recommended for vertical hanging and standing applications

Width Index	Standard	Part No. full set KMA pivoting:	Part No. full set KMA locking:	Bi [mm]	Width Index	Standard	Part No. full set KMA pivoting:	Part No. full set KMA locking:	Bi [mm]
05.	▶	141400.	- 05.12.C	140400.	- 05.12.C	50			
06.	▶	141400.	- 06.12.C	140400.	- 06.12.C	65			
07.	▶	141400.	189400.07.12.C	140400.188400.07.12.C	75				
08.	▶	141400.	- 08.12.C	140400.	- 08.12.C	87			
10.	▶	141400.	189400.10.12.C	140400.188400.10.12.C	100				
11.	▶	141400.	- 11.12.C	140400.	- 11.12.C	112			
12.	▶	141400.	189400.12.12.C	140400.188400.12.12.C	125				
13.	▶	141400.	- 13.12.C	140400.	- 13.12.C	137			
15.	▶	141400.	189400.15.12.C	140400.188400.15.12.C	150				
16.	▶	141400.	- 16.12.C	140400.	- 16.12.C	162			
17.	▶	141400.	189400.17.12.C	140400.188400.17.12.C	175				
18.	▶	141400.	- 18.12.C	140400.	- 18.12.C	187			
20.	▶	141400.	189400.20.12.C	140400.188400.20.12.C	200				
21.	▶	141400.	- 21.12.C	140400.	- 21.12.C	212			
22.	▶	141400.	- 22.12.C	140400.	- 22.12.C	225			
23.	▶	141400.	- 23.12.C	140400.	- 23.12.C	237			
25.	▶	141400.	189400.25.12.C	140400.188400.25.12.C	250				
26.	▶	141400.	- 26.12.C	140400.	- 26.12.C	262			
27.	▶	141400.	189400.27.12.C	140400.188400.27.12.C	275				
28.	▶	141400.	- 28.12.C	140400.	- 28.12.C	287			
30.	▶	141400.	189400.30.12.C	140400.188400.30.12.C	300				
31.	▶	141400.	- 31.12.C	140400.	- 31.12.C	312			
32.	▶	141400.	- 32.12.C	140400.	- 32.12.C	325			
33.	▶	141400.	- 33.12.C	140400.	- 33.12.C	337			
35.	▶	141400.	189400.35.12.C	140400.188400.35.12.C	350				
36.	▶	141400.	- 36.12.C	140400.	- 36.12.C	362			
37.	▶	141400.	- 37.12.C	140400.	- 37.12.C	375			
38.	▶	141400.	- 38.12.C	140400.	- 38.12.C	387			
40.	▶	141400.	189400.40.12.C	140400.188400.40.12.C	400				
41.	▶	141400.	- 41.12.C	140400.	- 41.12.C	412			
42.	▶	141400.	- 42.12.C	140400.	- 42.12.C	425			
43.	▶	141400.	- 43.12.C	140400.	- 43.12.C	437			
45.	▶	141400.	- 45.12.C	140400.	- 45.12.C	450			
46.	▶	141400.	189400.46.12.C	140400.188400.46.12.C	462				
47.	▶	141400.	- 47.12.C	140400.	- 47.12.C	475			
48.	▶	141400.	- 48.12.C	140400.	- 48.12.C	487			
50.	▶	141400.	- 50.12.C	140400.	- 50.12.C	500			
51.	▶	141400.	- 51.12.C	140400.	- 51.12.C	512			
52.	▶	141400.	- 52.12.C	140400.	- 52.12.C	525			
53.	▶	141400.	- 53.12.C	140400.	- 53.12.C	537			
55.	▶	141400.	- 55.12.C	140400.	- 55.12.C	550			
60.	▶	141400.	- 60.12.C	140400.	- 60.12.C	600			

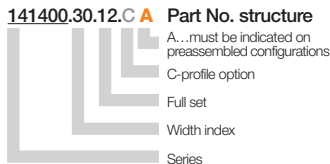
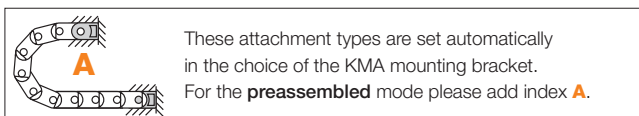

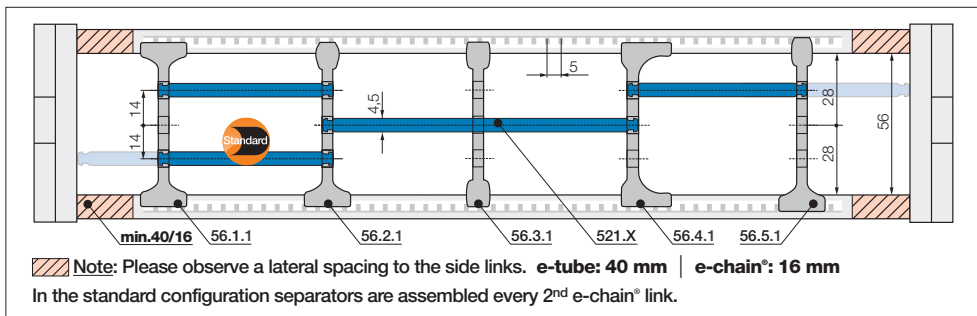

**Standard separator, wide base**  
unassembled **56.1**  
assembled **56.1.1**

### Standard - for all applications

Separator with a wide base for maximum locking strength and safe standing in e-chains® and e-tubes.

**Separator for QuickLock crossbar**  
unassembled **56.2**  
assembled **56.2.1**

### For even faster installation

Separator for igus® QuickLock crossbar 450.X.Q. Firm hold to one side with a wide base, narrow on opposed side for easy cable assembly (slight grip). For e-tubes also.

**Separator, narrow base**  
unassembled **56.3**  
assembled **56.3.1**

### For many thin cables

Separator with a narrow base for a large number of thin cables side by side. Saves space in e-chains® and e-tubes. Also available for QuickLock crossbars.

**Separator, asymmetrical**  
unassembled **56.4**  
assembled **56.4.1**

### For side-mounted applications

Asymmetrical separator, for defined distance. No additional spacers necessary for e-chains® and e-tubes.

**Notch separator for notch crossbar**  
unassembled **56.5**  
assembled **56.5.1**

### Locks safely in 5 mm increments

Notch separator for the new notch crossbar, with scaling on the notch crossbars. For exact positioning in e-chains® and e-tubes. Recommended for side-mounted applications.

**Full-width shelf, lockable**  
unassembled **520.X**  
assembled **521.X**

### Horizontal separation

Shelf locks safely into separators on both ends, fixed width possible. Separators can be moved freely over the shelf in horizontal direction. Can be arranged at 3 different heights.

### Lockable full-width shelves



Width X [mm]	unassembled	assembled	Width X [mm]	unassembled	assembled	Width X [mm]	unassembled	assembled
050	520.050	521.050	125	520.125	521.125	225	520.225	521.225
065	520.065	521.065	150	520.150	521.150	250	520.250	521.250
075	520.075	521.075	175	520.175	521.175	300	520.300	521.300
100	520.100	521.100	200	520.200	521.200	450	520.450	521.450

# E4/light | 14040·14140·R18840 | Further Accessories

## Extension links | Extender crossbars

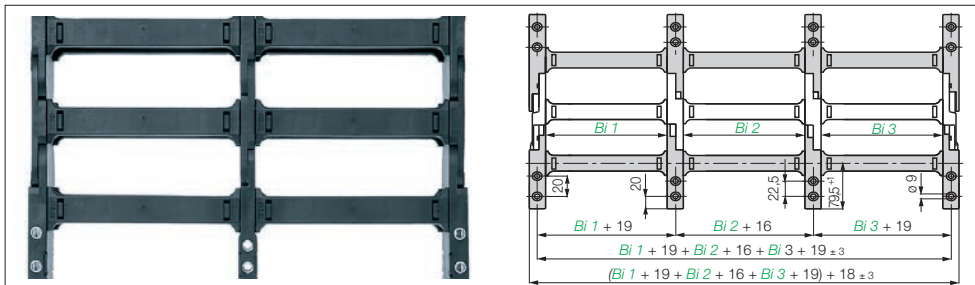

### Extension links | For extremely wide e-chains® up to 3,0 m

- Virtually limitless side-by-side attachment for high fill weights necessitate extremely wide e-chains® (up to 3000 mm)
- The unsupported length  $FL_G$  max. can be increased when additional loads are required

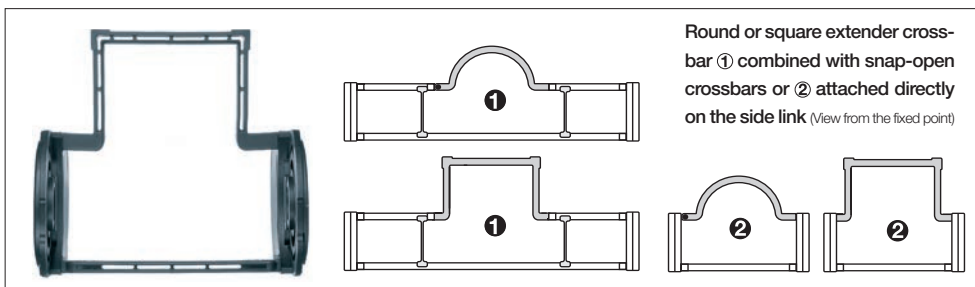

### Extender crossbars | Safe guiding for large hoses

- Suitable for hoses with a maximum outer diameter of 245 mm
- Gliding with crossbars assembled along outer radius and a special guide trough
- Extender crossbar ① for snap-open crossbars or ② attached directly on the side link

Part No. single part	Max Ø [mm] hose	Form	② Installation on side link	① Combination with snap-open crossbars
450.15.RHD115	115	○ round	no	yes
450.17.RD115	115	○ round	yes	no
450.25.D150	150	□ square	yes	no
450.30.D200	180	□ square	yes	no
450.35.D250	195	□ square	yes	no
450.40.D300	245	□ square	yes	no
450.20.HD150	150	□ square	no	yes
450.25.HD200	180	□ square	no	yes
450.30.HD250	195	□ square	no	yes

**E4 snapclip - clip-on cable binder**

● For side-mounted applications ● Serves as a clip-on, lateral guide for hoses and cables on e-chains\* ● The loops can be adjusted as required ● Compatible with many E4 e-chains\* ● One clip and one locking band are needed for each e-chain\* link. **The complete range with order options ► [www.igus.eu/eu/14040](http://www.igus.eu/eu/14040)**

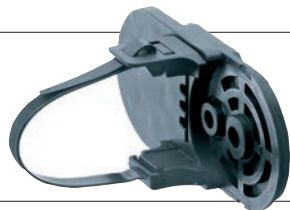

**The igus® e-chain® opener reduces assembly time**

e-chain® opener tools for convenient opening and closing of E4 series igus® e-chains\* ● Especially for e-chains\* with many crossbars the assembly is much easier ● Especially in areas difficult to access mounting is simplified big savings in assembly time. Please call us or ► [www.igus.eu/eu/E4savetime](http://www.igus.eu/eu/E4savetime)



**Optional: Support tray tool kit.**

**For support of the lower run.**

Simple one-piece support trays according to your requirements and specification. **The complete range with order options ► from page 714**



Handling unit inhouse crane - long unsupported span with an igus® E4 Series



e-chains® | Series 14240 crossbars every link (crossbars removable along both radii)

e-chains® | Series 14340 crossbars every 2<sup>nd</sup> link (crossbars removable along both radii)

Part No. e-chains <sup>®</sup>	<i>Bi</i> [mm]	<i>Ba</i> [mm]	14240 [kg/m]	14340 [kg/m]
14240.14340.05. <i>R.0</i>	50	76	≈ 2,37	≈ 2,32
14240.14340.06. <i>R.0</i>	68	94	≈ 2,40	≈ 2,33
14240.14340.07. <i>R.0</i>	75	101	≈ 2,42	≈ 2,34
14240.14340.087. <i>R.0</i>	87	114	≈ 2,47	≈ 2,36
14240.14340.097. <i>R.0</i>	97	123	≈ 2,51	≈ 2,38
14240.14340.10. <i>R.0</i>	100	126	≈ 2,52	≈ 2,39
14240.14340.11. <i>R.0</i>	108	134	≈ 2,55	≈ 2,40
14240.14340.112. <i>R.0</i>	112	139	≈ 2,55	≈ 2,41
14240.14340.12. <i>R.0</i>	125	151	≈ 2,62	≈ 2,44
14240.14340.137. <i>R.0</i>	137	164	≈ 2,66	≈ 2,46
14240.14340.15. <i>R.0</i>	150	176	≈ 2,72	≈ 2,49
14240.14340.162. <i>R.0</i>	162	189	≈ 2,73	≈ 2,49
14240.14340.17. <i>R.0</i>	168	194	≈ 2,79	≈ 2,52
14240.14340.18. <i>R.0</i>	175	201	≈ 2,82	≈ 2,53
14240.14340.187. <i>R.0</i>	187	214	≈ 2,84	≈ 2,55
14240.14340.20. <i>R.0</i>	200	226	≈ 2,89	≈ 2,58

Part No. e-chains <sup>®</sup>	<i>Bi</i> [mm]	<i>Ba</i> [mm]	14240 [kg/m]	14340 [kg/m]
14240.14340.212. <i>R.0</i>	212	239	≈ 2,95	≈ 2,60
14240.14340.23. <i>R.0</i>	225	251	≈ 3,01	≈ 2,63
14240.14340.237. <i>R.0</i>	237	264	≈ 3,04	≈ 2,65
14240.14340.25. <i>R.0</i>	250	276	≈ 3,10	≈ 2,68
14240.14340.262. <i>R.0</i>	262	289	≈ 3,11	≈ 2,69
14240.14340.28. <i>R.0</i>	275	301	≈ 3,19	≈ 2,72
14240.14340.29. <i>R.0</i>	287	314	≈ 3,20	≈ 2,73
14240.14340.30. <i>R.0</i>	300	326	≈ 3,30	≈ 2,78
14240.14340.312. <i>R.0</i>	312	339	≈ 3,31	≈ 2,79
14240.14340.325. <i>R.0</i>	325	351	≈ 3,37	≈ 2,81
14240.14340.337. <i>R.0</i>	337	364	≈ 3,40	≈ 2,83
14240.14340.350. <i>R.0</i>	350	376	≈ 3,56	≈ 2,91
14240.14340.362. <i>R.0</i>	362	389	≈ 3,61	≈ 2,93
14240.14340.375. <i>R.0</i>	375	401	≈ 3,64	≈ 2,95
14240.14340.387. <i>R.0</i>	387	414	≈ 3,69	≈ 2,97
14240.14340.400. <i>R.0</i>	400	426	≈ 3,73	≈ 2,99

<sup>1)</sup> Removable lid only, no hinged option

Available bending radii *R* [mm] 135 | 150 | 175 | 200 | 250 | 300 | 400 | 500

Supplement Part No. with required radius (*R*). Examples:

14240.20.300.0 = e-chain® with crossbars every link, inner width *Bi* 200 mm, radius *R* 300 mm, color black

14340.20.300.0 = e-chain® with crossbars every 2<sup>nd</sup> link, inner width *Bi* 200 mm, radius *R* 300 mm, color black



ESD/ATEX permanently conductive e-chains® - 14240 several widths with delivery from stock:  
Inner widths *Bi* 50 - 200, radii *R* 150 - 250. Full ESD delivery program ► [www.igus.eu/eu/ESD](http://www.igus.eu/eu/ESD)





## Unsupported applications | Short travels

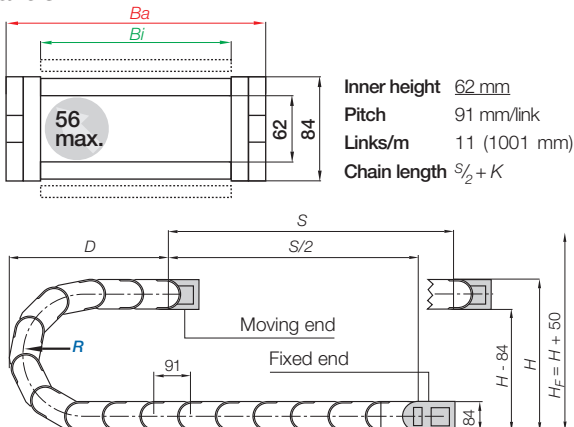
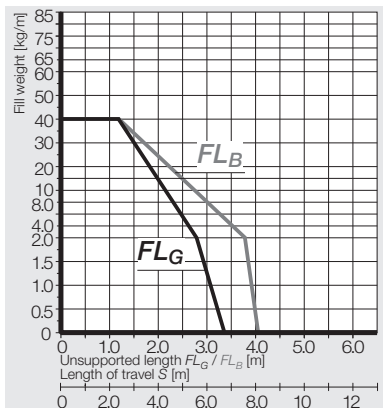

$R$	135	150	175	200	250	300	400	500
$H_{+25}^0$	354	384	434	484	584	684	884	1084
$D$	314	329	354	379	429	479	579	679
$K$	610	655	735	815	970	1125	1440	1755

The required clearance height:  $H_F = H + 50$  mm (with 2,0 kg/m fill weight)

## Gliding applications | Long travels from 12 m to max. 250 m

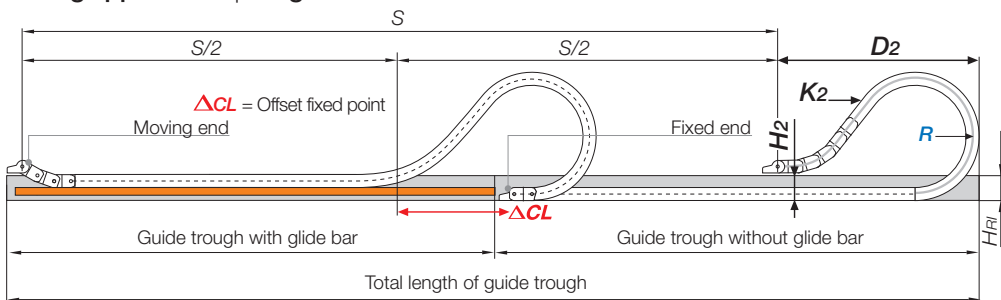

**Note:** For long travel applications with more than 100 m we recommend to realize the engineering of such a plant by our technicians. In case of travels between 9 and 12 m we recommend a longer unsupported length. **Chain length**  $S/2 + K_2$

$R$	135	150	175	200	250	300	400	500
$H_2$	266	266	266	266	266	266	266	266
$D_2^{+25}$	390	450	550	710	920	1120	1530	1850
$K_2$	728	819	1001	1274	1638	1911	2548	3185
$\Delta CL$	124	159	209	359	509	659	959	1159

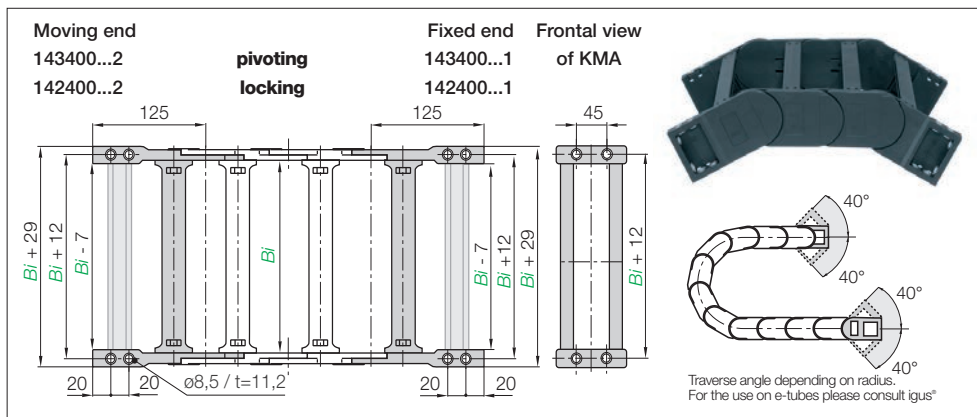

**KMA pivoting** | Standard | Recommended for unsupported and gliding applications  
**KMA locking** | Recommended for vertical hanging and standing applications

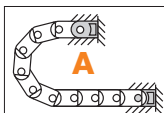

Width Index	Standard	Part No. full set KMA pivoting:	Part No. full set KMA locking:	Bi [mm]	Width Index	Standard	Part No. full set KMA pivoting:	Part No. full set KMA locking:	Bi [mm]
05.	▶	143400.05. 12.C	142400.05. 12.C	50	212.	▶	143400.212.12.C	142400.212.12.C	212
06.	▶	143400.06. 12.C	142400.06. 12.C	68	23.	▶	143400.23. 12.C	142400.23. 12.C	225
07.	▶	143400.07. 12.C	142400.07. 12.C	75	237.	▶	143400.237.12.C	142400.237.12.C	237
087.	▶	143400.087.12.C	142400.087.12.C	87	25.	▶	143400.25. 12.C	142400.25. 12.C	250
097.	▶	143400.097.12.C	142400.097.12.C	97	262.	▶	143400.262.12.C	142400.262.12.C	262
10.	▶	143400.10. 12.C	142400.10. 12.C	100	28.	▶	143400.28. 12.C	142400.28. 12.C	275
11.	▶	143400.11. 12.C	142400.11. 12.C	108	29.	▶	143400.29. 12.C	142400.29. 12.C	287
112.	▶	143400.112.12.C	142400.112.12.C	112	30.	▶	143400.30. 12.C	142400.30. 12.C	300
12.	▶	143400.12. 12.C	142400.12. 12.C	125	312.	▶	143400.312.12.C	142400.312.12.C	312
137.	▶	143400.137.12.C	142400.137.12.C	137	325.	▶	143400.325.12.C	142400.325.12.C	325
15.	▶	143400.15. 12.C	142400.15. 12.C	150	337.	▶	143400.337.12.C	142400.337.12.C	337
162.	▶	143400.162.12.C	142400.162.12.C	162	350.	▶	143400.350.12.C	142400.350.12.C	350
17.	▶	143400.17. 12.C	142400.17. 12.C	168	362.	▶	143400.362.12.C	142400.362.12.C	362
18.	▶	143400.18. 12.C	142400.18. 12.C	175	375.	▶	143400.375.12.C	142400.375.12.C	375
187.	▶	143400.187.12.C	142400.187.12.C	187	387.	▶	143400.387.12.C	142400.387.12.C	387
20.	▶	143400.20. 12.C	142400.20. 12.C	200	400.	▶	143400.400.12.C	142400.400.12.C	400

**143400.20.12.C A** Part No. structure  
 A...must be indicated on preassembled configurations  
 C-profile option  
 Full set  
 Width index  
 Series

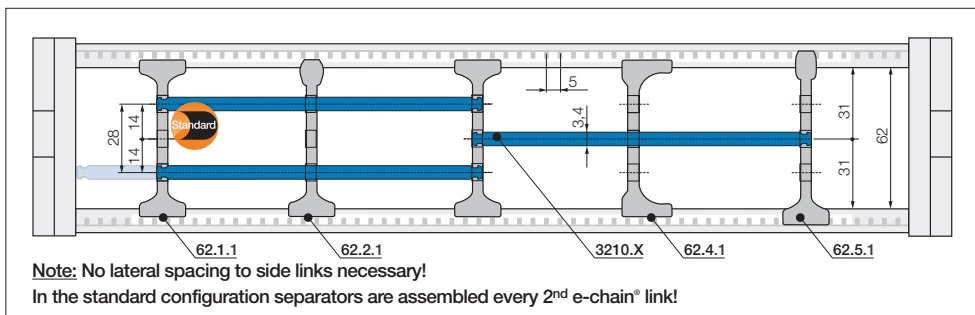

These attachment types are set automatically in the choice of the KMA mounting bracket. For the **preassembled** mode please add index **A**.

**Strain relief** e.g. clamps, tiewrap plates, nuggets and plug-in clips are available from stock. The complete chainfix range with order options ▶ from page 630





**Standard separator, wide base**

unassembled	62.1
assembled	62.1.1

### Standard - for all applications

Separator with a wide base for maximum locking strength and safe standing in e-chains®.



**Separator for QuickLock crossbar**

unassembled	62.2
assembled	62.2.1

### For even faster installation

Separator for igus® QuickLock crossbar 385.X.Q. Firm hold to one side with a wide base, narrow on opposed side for easy cable assembly (slight grip).



**Separator, asymmetrical\***

unassembled	62.4
assembled	62.4.1

### For side-mounted applications

Asymmetrical separator, for defined distance. No additional spacers necessary for e-chains®.

\*Available upon request, please consult igus® for delivery time



**Notch separator for notch crossbar**

unassembled	62.5
assembled	62.5.1

### Locks safely in 5 mm increments

Notch separator for the new notch crossbar, with scaling on the notch crossbars. For exact positioning in e-chains®. Recommended for side-mounted applications.



**Full-width shelf, lockable**

unassembled	3200.X
assembled	3210.X

### Horizontal separation

Shelf locks safely into separators on both ends, fixed width possible. Separators can be moved freely over the shelf in horizontal direction. Can be arranged at 3 different heights.

### Lockable full-width shelves



Width X [mm]	unassembled	assembled	Width X [mm]	unassembled	assembled	Width X [mm]	unassembled	assembled
050	3200.050	3210.050	125	3200.125	3210.125	225	3200.225	3210.225
075	3200.075	3210.075	150	3200.150	3210.150	250	3200.250	3210.250
100	3200.100	3210.100	175	3200.175	3210.175			
115	3200.115	3210.115	200	3200.200	3210.200			

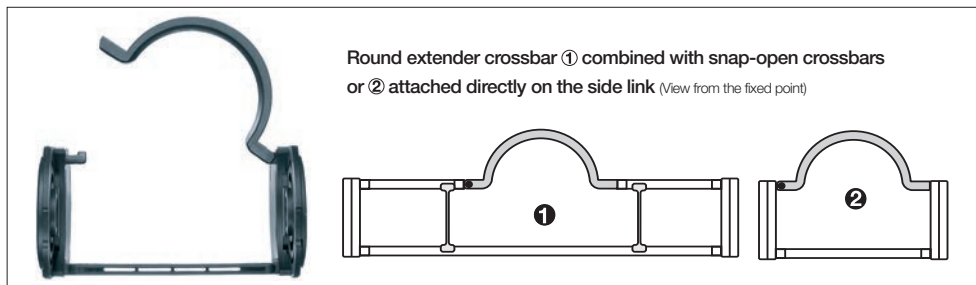

Round extender crossbar ① combined with snap-open crossbars or ② attached directly on the side link (View from the fixed point)

### Extender crossbars | Safe guiding for large hoses

- Suitable for hoses with a maximum outer diameter of 115 mm
- Gliding with crossbars assembled along outer radius and a special guide trough
- Extender crossbar ① for snap-open crossbars or ② attached directly on the side link

Part No. single part	Max Ø [mm] hose	Form	② Installation on side link	① Combination with snap-open crossbars
385.15.RHD115	115	○ round	no	yes
385.18.RD115	115	○ round	yes	no

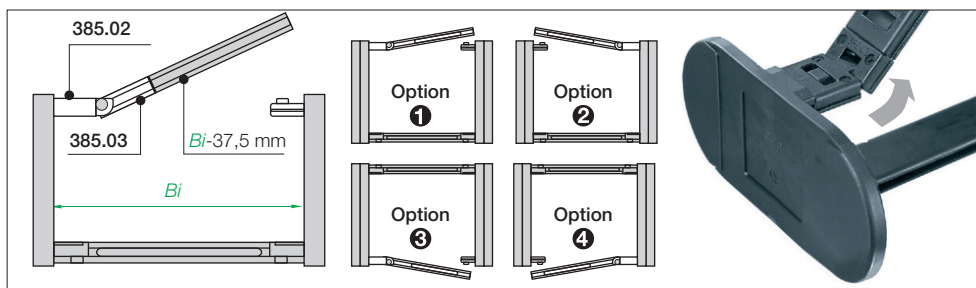

### Hinged crossbars | When snap-open crossbars have to remain attached

- Please consult igus® for design assistance
- Hinged crossbar: Part No. 385.02
- Snap-open crossbar (shortened):  $Bi-37,5$  mm Part No. 385.03 (smallest inner width  $Bi = 87,5$ )

Optional: **Support tray tool kit.**

**For support of the lower run.**

Simple one-piece support trays according to your requirements and specification.  
The complete range with order options ► from page 714



E4/light e-tubes protect tubes and hoses safely against dirt and chips

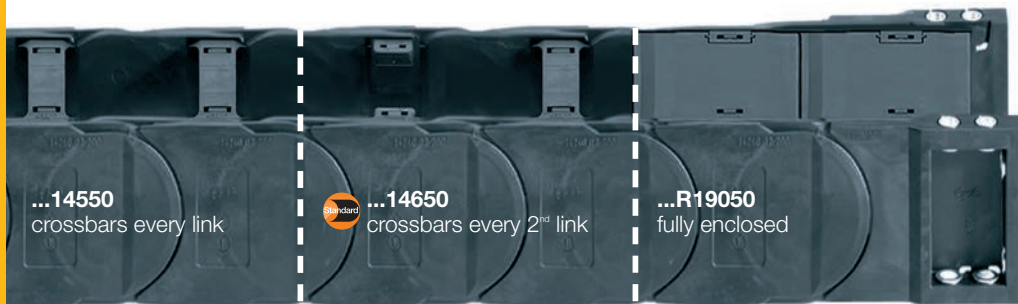

e-chains® | Series 14550 crossbars every link (crossbars removable along both radii)

e-chains® | Series 14650 crossbars every 2<sup>nd</sup> link (crossbars removable along both radii)

e-tubes | Series R19050 fully enclosed (hinged snap-open removable lids along outer radius)

Part No. e-chains® / e-tubes		<i>Bi</i> [mm]	<i>Ba</i> [mm]	14550 [kg/m]	14650 [kg/m]	19050 [kg/m]
14550.14650.	- 05.R.0	50	77	≈ 3,28	≈ 3,27	-
14550.14650.	- 06.R.0	65	92	≈ 3,37	≈ 3,31	-
14550.14650.19050.07.R.0		75	102	≈ 3,44	≈ 3,35	≈ 4,00
14550.14650.	- 08.R.0	87	114	≈ 3,52	≈ 3,38	-
14550.14650.19050.10.R.0		100	127	≈ 3,61	≈ 3,43	≈ 4,33
14550.14650.	- 11.R.0	112	139	≈ 3,73	≈ 3,49	-
14550.14650.19050.12.R.0		125	152	≈ 3,81	≈ 3,53	≈ 4,70
14550.14650.	- 13.R.0	137	164	≈ 3,94	≈ 3,60	-
14550.14650.19050.15.R.0		150	177	≈ 3,98	≈ 3,62	≈ 5,04
14550.14650.	- 16.R.0	162	189	≈ 4,09	≈ 3,67	-
14550.14650.19050.17.R.0		175	202	≈ 4,23	≈ 3,74	≈ 5,41
14550.14650.	- 18.R.0	187	214	≈ 4,34	≈ 3,80	-
14550.14650.19050.20.R.0		200	227	≈ 4,39	≈ 3,82	≈ 5,64
14550.14650.	- 21.R.0	212	239	≈ 4,46	≈ 3,86	-
14550.14650.	- 22.R.0	225	252	≈ 4,53	≈ 3,89	-
14550.14650.	- 23.R.0	237	264	≈ 4,64	≈ 3,95	-
14550.14650.19050.25.R.0		250	277	≈ 4,76	≈ 4,00	≈ 6,32
14550.14650.	- 26.R.0	262	289	≈ 4,85	≈ 4,05	-
14550.14650.19050.27.R.0		275	302	≈ 4,95	≈ 4,10	≈ 6,65
14550.14650.	- 28.R.0	287	314	≈ 5,01	≈ 4,13	-
14550.14650.19050.30.R.0		300	327	≈ 5,16	≈ 4,21	≈ 6,99

Part No. e-chains® / e-tubes		<i>Bi</i> [mm]	<i>Ba</i> [mm]	14550 [kg/m]	14650 [kg/m]	19050 [kg/m]
14550.14650.	- 31.R.0	312	339	≈ 5,20	≈ 4,23	-
14550.14650.	- 32.R.0	325	352	≈ 5,30	≈ 4,28	-
14550.14650.	- 33.R.0	337	364	≈ 5,42	≈ 4,34	-
14550.14650.19050.35.R.0		350	377	≈ 5,62	≈ 4,44	≈ 7,68
14550.14650.	- 36.R.0	362	389	≈ 5,53	≈ 4,39	-
14550.14650.	- 37.R.0	375	402	≈ 5,63	≈ 4,44	-
14550.14650.	- 38.R.0	387	414	≈ 5,74	≈ 4,50	-
14550.14650.19050.40.R.0		400	427	≈ 6,01	≈ 4,63	≈ 8,36
14550.14650.	- 41.R.0	412	439	≈ 5,94	≈ 4,60	-
14550.14650.	- 42.R.0	425	452	≈ 6,23	≈ 4,74	-
14550.14650.	- 43.R.0	437	464	≈ 6,07	≈ 4,66	-
14550.14650.	- 45.R.0	450	477	≈ 6,40	≈ 4,83	-
14550.14650.19050.46.R.0		462	489	≈ 6,35	≈ 4,80	≈ 9,21
14550.14650.	- 47.R.0	475	502	≈ 6,39	≈ 4,82	-
14550.14650.	- 48.R.0	487	514	≈ 6,64	≈ 4,95	-
14550.14650.	- 50.R.0	500	527	≈ 6,74	≈ 5,00	-
14550.14650.	- 51.R.0	512	539	≈ 6,65	≈ 4,95	-
14550.14650.	- 52.R.0	525	552	≈ 6,82	≈ 5,04	-
14550.14650.	- 53.R.0	537	564	≈ 6,92	≈ 5,09	-
14550.14650.	- 55.R.0	550	577	≈ 7,34	≈ 5,30	-
14550.14650.	- 60.R.0	600	627	≈ 7,57	≈ 5,41	-

\*Radius not available for e-tubes

Available bending radii *R* [mm] 150\* | 175\* | 200 | 250 | 300 | 350 | 400 | 450 | 500 | 600

Supplement Part No. with required radius (*R*). Examples:

14550.30.300.0 = e-chain® with crossbars every link, inner width *Bi* 300 mm, radius *R* 300 mm, color black

14650.30.300.0 = e-chain® with crossbars every 2<sup>nd</sup> link, inner width *Bi* 300 mm, radius *R* 300 mm, color black

19050.30.300.0 = e-tube fully enclosed, inner width *Bi* 300 mm, radius *R* 300 mm, color black



## Unsupported applications | Short travels

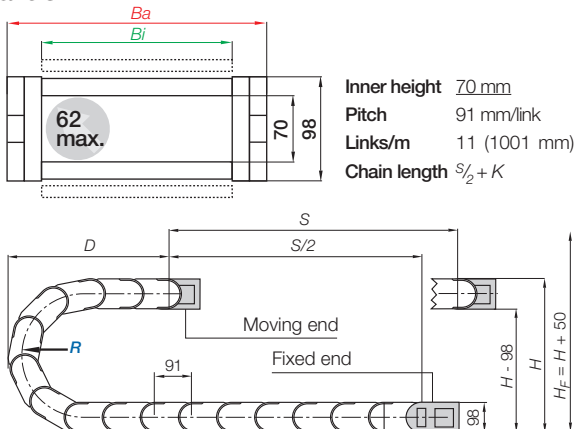
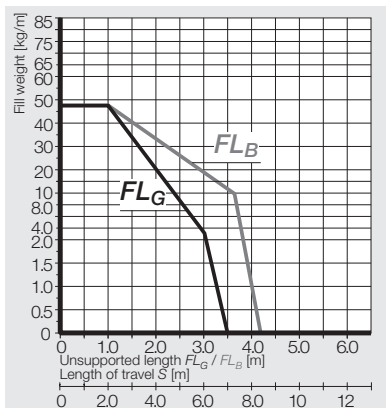

	150*	175*	200	250	300	350	400	450	500	600
<b>R</b>	150*	175*	200	250	300	350	400	450	500	600
<b>H</b>	398	448	498	598	698	798	898	998	1098	1298
<b>D</b>	336	361	386	436	486	536	586	636	686	786
<b>K</b>	655	735	815	970	1125	1285	1440	1600	1755	2070

The required clearance height:  $H_F = H + 50$  mm (with 2,5 kg/m fill weight)

\*Radius not available for e-tubes

## Gliding applications | Long travels from 12 m to max. 250 m

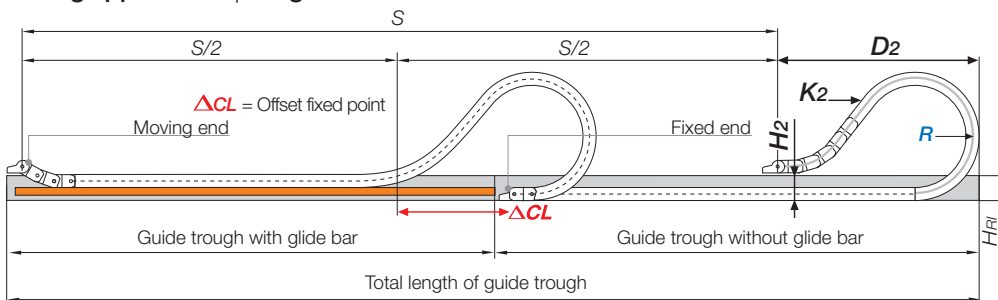

**Note:** For long travel applications with more than 100 m we recommend to realize the engineering of such a plant by our technicians. In case of travels between 8 and 12 m we recommend a longer unsupported length. **Chain length**  $S/2 + K_2$

	150*	175*	200	250	300	350	400	450	500	600
<b>R</b>	150*	175*	200	250	300	350	400	450	500	600
<b>H<sub>2</sub></b>	266	266	266	266	266	266	266	266	266	2)
<b>D<sub>2</sub>+25</b>	450	530	710	920	1120	1340	1530	1)	1830	2)
<b>K<sub>2</sub></b>	819	1001	1274	1638	1911	2184	2548	1)	3185	2)
<b>ΔCL</b>	124	159	209	359	509	659	829	959	1159	2)

\*Radius not available for e-tubes 1) Values upon request 2) Please note: For using \*R 600 for long travels (gliding), please consult igus® first.

# E4/light | 14550·14650·R19050 | Accessories

KMA mounting brackets | Attachment on all sides | pivoting | locking

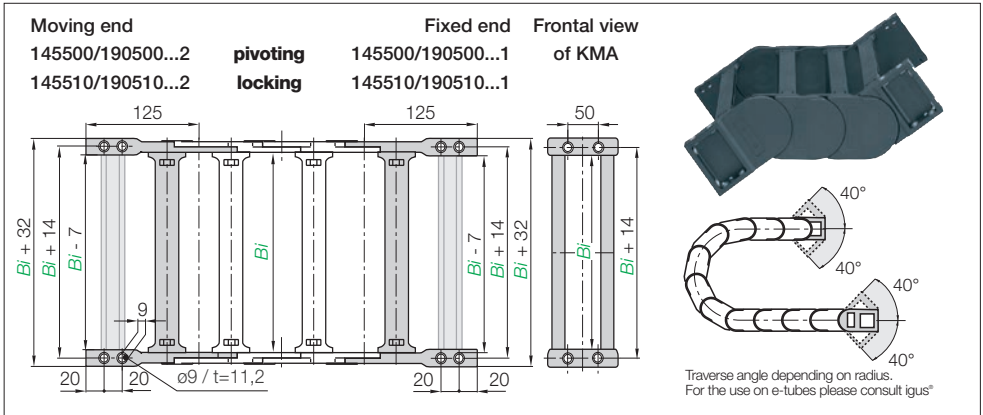

**KMA pivoting** | Standard | Recommended for unsupported and gliding applications  
**KMA locking** | Recommended for vertical hanging and standing applications

Width Index	Standard	Part No. full set KMA pivoting:	Part No. full set KMA locking:	Bi [mm]	Width Index	Standard	Part No. full set KMA pivoting:	Part No. full set KMA locking:	Bi [mm]				
05.	▶	145500.-	05.12.C	145510.-	05.12.C	50	31.	▶	146500.-	31.12.C	145510.-	31.12.C	312
06.	▶	145500.-	06.12.C	145510.-	06.12.C	65	32.	▶	146500.-	32.12.C	145510.-	32.12.C	325
07.	▶	145500.	190500.07.12.C	145510.	190510.07.12.C	75	33.	▶	146500.-	33.12.C	145510.-	33.12.C	337
08.	▶	145500.-	08.12.C	145510.-	08.12.C	87	35.	▶	146500.	190500.35.12.C	145510.	190510.35.12.C	350
10.	▶	145500.	190500.10.12.C	145510.	190510.10.12.C	100	36.	▶	146500.-	36.12.C	145510.-	36.12.C	362
11.	▶	145500.-	11.12.C	145510.-	11.12.C	112	37.	▶	146500.-	37.12.C	145510.-	37.12.C	375
12.	▶	145500.	190500.12.12.C	145510.	190510.12.12.C	125	38.	▶	146500.-	38.12.C	145510.-	38.12.C	387
13.	▶	145500.-	13.12.C	145510.-	13.12.C	137	40.	▶	146500.	190500.40.12.C	145510.	190510.40.12.C	400
15.	▶	145500.	190500.15.12.C	145510.	190510.15.12.C	150	41.	▶	146500.-	41.12.C	145510.-	41.12.C	412
16.	▶	145500.-	16.12.C	145510.-	16.12.C	162	42.	▶	146500.-	42.12.C	145510.-	42.12.C	425
17.	▶	145500.	190500.17.12.C	145510.	190510.17.12.C	175	43.	▶	146500.-	43.12.C	145510.-	43.12.C	437
18.	▶	145500.-	18.12.C	145510.-	18.12.C	187	45.	▶	146500.-	45.12.C	145510.-	45.12.C	450
20.	▶	145500.	190500.20.12.C	145510.	190510.20.12.C	200	46.	▶	146500.	190500.46.12.C	145510.	190510.46.12.C	462
21.	▶	145500.-	21.12.C	145510.-	21.12.C	212	47.	▶	146500.-	47.12.C	145510.-	47.12.C	475
22.	▶	145500.-	22.12.C	145510.-	22.12.C	225	48.	▶	146500.-	48.12.C	145510.-	48.12.C	487
23.	▶	145500.-	23.12.C	145510.-	23.12.C	237	50.	▶	146500.-	50.12.C	145510.-	50.12.C	500
25.	▶	145500.	190500.25.12.C	145510.	190510.25.12.C	250	51.	▶	146500.-	51.12.C	145510.-	51.12.C	512
26.	▶	145500.-	26.12.C	145510.-	26.12.C	262	52.	▶	146500.-	52.12.C	145510.-	52.12.C	525
27.	▶	145500.	190500.27.12.C	145510.	190510.27.12.C	275	53.	▶	146500.-	53.12.C	145510.-	53.12.C	537
28.	▶	145500.-	28.12.C	145510.-	28.12.C	287	55.	▶	146500.-	55.12.C	145510.-	55.12.C	550
30.	▶	145500.	190500.30.12.C	145510.	190510.30.12.C	300	60.	▶	146500.-	60.12.C	145510.-	60.12.C	600

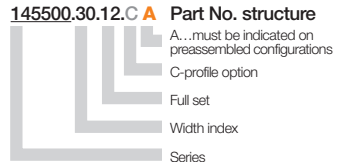
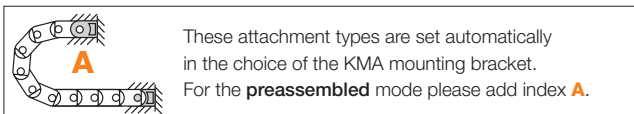



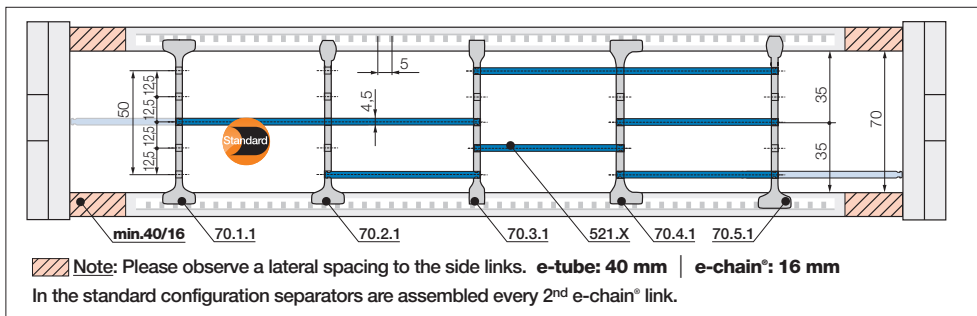
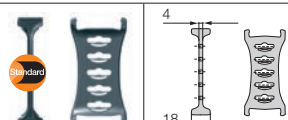



**Standard separator, wide base**

unassembled	70.1
assembled	70.1.1

### Standard - for all applications

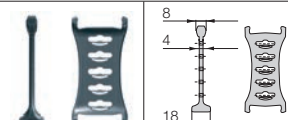
Separator with a wide base for maximum locking strength and safe standing in e-chains\* and e-tubes.



**Separator for QuickLock crossbar**

unassembled	70.2
assembled	70.2.1

### For even faster installation

Separator for igus® QuickLock crossbar 450.X.Q. Firm hold to one side with a wide base, narrow on opposed side for easy cable assembly (slight grip). For e-tubes also.

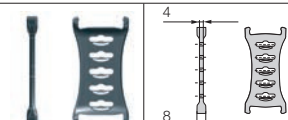

**Separator, narrow base**

unassembled	70.3
assembled	70.3.1

### For many thin cables

Separator with a narrow base for a large number of thin cables side by side. Saves space in e-chains\* and e-tubes. Also available for QuickLock crossbars.

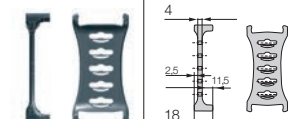

**Separator, asymmetrical**

unassembled	704
assembled	70.4.1

### For side-mounted applications

Asymmetrical separator, for defined distance. No additional spacers necessary for e-chains\* and e-tubes.

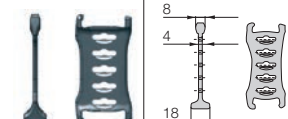

**Notch separator for notch crossbar**

unassembled	70.5
assembled	70.5.1

### Locks safely in 5 mm increments

Notch separator for the new notch crossbar, with scaling on the notch crossbars. For exact positioning in e-chains\* and e-tubes. Recommended for side-mounted applications.

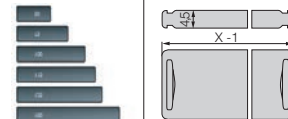

**Full-width shelf, lockable**

unassembled	520.X
assembled	521.X

### Horizontal separation

Shelf locks safely into separators on both ends, fixed width possible. Separators can be moved freely over the shelf in horizontal direction. Can be arranged at 5 different heights.

### Lockable full-width shelves



Width X [mm]	unassembled	assembled	Width X [mm]	unassembled	assembled	Width X [mm]	unassembled	assembled
050	520.050	521.050	125	520.125	521.125	225	520.225	521.225
065	520.065	521.065	150	520.150	521.150	250	520.250	521.250
075	520.075	521.075	175	520.175	521.175	300	520.300	521.300
100	520.100	521.100	200	520.200	521.200	450	520.450	521.450

# E4/light | 14550·14650·R19050 | Further Accessories

## Extension links | Extender crossbars

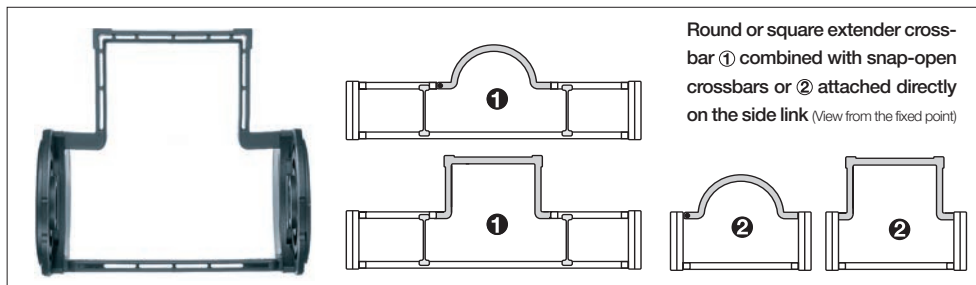

### Extender crossbars | Safe guiding for large hoses

- Suitable for hoses with a maximum outer diameter of 270 mm
- Gliding with crossbars assembled along outer radius and a special guide trough
- Extender crossbar ① for snap-open crossbars or ② attached directly on the side link

Part No. single part	Max Ø [mm] hose	Form	② Installation on side link	① Combination with snap-open crossbars
450.15.RHD115	115	○ round	no	yes
450.17.RD115	115	○ round	yes	no
450.25.D150	150	□ square	yes	no
450.30.D200	200	□ square	yes	no
450.35.D250	220	□ square	yes	no
450.40.D300	270	□ square	yes	no
450.20.HD150	150	□ square	no	yes
450.25.HD200	200	□ square	no	yes
450.30.HD250	220	□ square	no	yes

**The igus® e-chain® opener reduces assembly time**

e-chain® opener tools for convenient opening and closing of E4 series igus® e-chains® ● Especially for e-chains® with many crossbars the assembly is much easier ● Especially in areas difficult to access mounting is simplified big savings in assembly time. Please call us or ► [www.igus.eu/eu/E4savetime](http://www.igus.eu/eu/E4savetime)

**Optional: Support tray tool kit.****For support of the lower run.**

Simple one-piece support trays according to your requirements and specification.  
The complete range with order options ► from page 714



Spray-painting robot with System E4 e-chain® used in an ATEX version made of igumid ESD.

High accelerations of up to  $6 \text{ m/s}^2$  and high braking rates with a weight of the robot of approx. one ton



"Light Design", large inner height

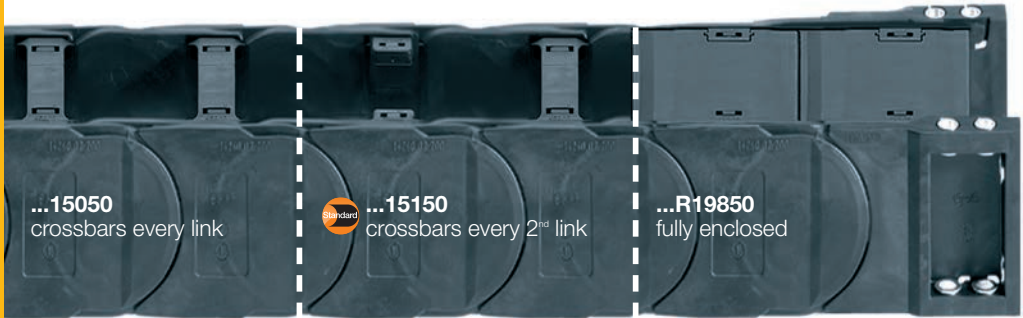

e-chains® | Series 15050 crossbars every link (crossbars removable along both radii)

e-chains® | Series 15150 crossbars every 2<sup>nd</sup> link (crossbars removable along both radii)

e-tubes | Series R19850 fully enclosed (hinged snap-open removable lids along outer radius)

Part No. e-chains® / e-tubes		<i>Bi</i>	<i>Ba</i>	15050	15150	19850
		[mm]	[mm]	[kg/m]	[kg/m]	[kg/m]
15050.15150.	- 05.R.0	50	80	≈ 3,85	≈ 3,84	-
15050.15150.	- 06.R.0	65	95	≈ 3,95	≈ 3,88	-
15050.15150.19850.07.R.0		75	105	≈ 4,00	≈ 3,92	≈ 4,46
15050.15150.	- 08.R.0	87	117	≈ 4,05	≈ 3,96	-
15050.15150.19850.10.R.0		100	130	≈ 4,18	≈ 4,00	≈ 4,74
15050.15150.	- 11.R.0	112	143	≈ 4,31	≈ 4,07	-
15050.15150.19850.12.R.0		125	155	≈ 4,38	≈ 4,10	≈ 5,10
15050.15150.	- 13.R.0	137	168	≈ 4,51	≈ 4,17	-
15050.15150.19850.15.R.0		150	180	≈ 4,58	≈ 4,20	≈ 5,53
15050.15150.	- 16.R.0	162	193	≈ 4,69	≈ 4,26	-
15050.15150.19850.17.R.0		175	205	≈ 4,80	≈ 4,31	≈ 5,88
15050.15150.	- 18.R.0	187	218	≈ 4,91	≈ 4,37	-
15050.15150.19850.20.R.0		200	230	≈ 4,93	≈ 4,38	≈ 6,11
15050.15150.	- 21.R.0	212	243	≈ 5,04	≈ 4,43	-
15050.15150.	- 22.R.0	225	255	≈ 5,10	≈ 4,47	-
15050.15150.	- 23.R.0	237	268	≈ 5,24	≈ 4,53	-
15050.15150.19850.25.R.0		250	280	≈ 5,32	≈ 4,58	≈ 6,83
15050.15150.	- 26.R.0	262	293	≈ 5,41	≈ 4,62	-
15050.15150.19850.27.R.0		275	305	≈ 5,52	≈ 4,68	≈ 7,26
15050.15150.	- 28.R.0	287	318	≈ 5,54	≈ 4,69	-
15050.15150.19850.30.R.0		300	330	≈ 5,76	≈ 4,80	≈ 7,49

Part No. e-chains® / e-tubes		<i>Bi</i>	<i>Ba</i>	15050	15150	19850
		[mm]	[mm]	[kg/m]	[kg/m]	[kg/m]
15050.15150.	- 31.R.0	312	343	≈ 5,80	≈ 4,82	-
15050.15150.	- 32.R.0	325	355	≈ 5,85	≈ 4,84	-
15050.15150.	- 33.R.0	337	368	≈ 6,03	≈ 4,93	-
15050.15150.19850.35.R.0		350	380	≈ 6,18	≈ 5,01	≈ 8,24
15050.15150.	- 36.R.0	362	393	≈ 6,19	≈ 5,02	-
15050.15150.	- 37.R.0	375	405	≈ 6,20	≈ 5,02	-
15050.15150.	- 38.R.0	387	418	≈ 6,29	≈ 5,06	-
15050.15150.19850.40.R.0		400	430	≈ 6,49	≈ 5,16	≈ 9,20
15050.15150.	- 41.R.0	412	443	≈ 6,64	≈ 5,24	-
15050.15150.	- 42.R.0	425	455	≈ 6,80	≈ 5,31	-
15050.15150.	- 43.R.0	437	468	≈ 6,86	≈ 5,35	-
15050.15150.	- 45.R.0	450	480	≈ 6,93	≈ 5,38	-
15050.15150.19850.46.R.0		462	493	≈ 6,95	≈ 5,39	≈ 9,66
15050.15150.	- 47.R.0	475	505	≈ 7,08	≈ 5,46	-
15050.15150.	- 48.R.0	487	518	≈ 7,16	≈ 5,49	-
15050.15150.	- 50.R.0	500	530	≈ 7,22	≈ 5,52	-
15050.15150.	- 51.R.0	512	543	≈ 7,24	≈ 5,53	-
15050.15150.	- 52.R.0	525	555	≈ 7,28	≈ 5,56	-
15050.15150.	- 53.R.0	537	568	≈ 7,44	≈ 5,63	-
15050.15150.	- 55.R.0	550	580	≈ 7,92	≈ 5,87	-
15050.15150.	- 60.R.0	600	630	≈ 8,12	≈ 5,97	-

\*Radius not available for e-tubes

Available bending radii *R* [mm] 150\* | 200 | 250 | 300 | 350 | 400 | 500 | 600

Supplement Part No. with required radius (*R*). Examples:

15050.30.300.0 = e-chain® with crossbars every link, inner width *Bi* 300 mm, radius *R* 300 mm, color black

15150.30.300.0 = e-chain® with crossbars every 2<sup>nd</sup> link, inner width *Bi* 300 mm, radius *R* 300 mm, color black

19850.30.300.0 = e-tube fully enclosed, inner width *Bi* 300 mm, radius *R* 300 mm, color black



ESD/ATEX permanently conductive e-chains® - 15050 several widths with delivery from stock:  
Inner widths *Bi* 75 - 300, radii *R* 150 - 250. Full ESD delivery program ► [www.igus.eu/eu/ESD](http://www.igus.eu/eu/ESD)



## Unsupported applications | Short travels

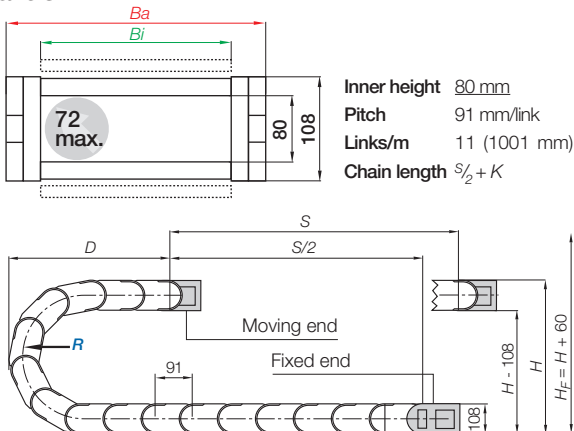
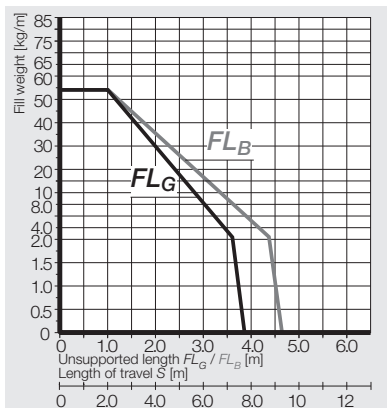

$R$	150*	200	250	300	350	400	500	600
$H_{+25}^0$	408	508	608	708	808	908	1108	1308
$D$	341	391	441	491	541	591	691	791
$K$	655	815	970	1125	1285	1440	1755	2070

The required clearance height:  $H_F = H + 60$  mm (with 3,0 kg/m fill weight)

\*Radius not available for e-tubes

## Gliding applications | Long travels from 12 m to max. 250 m

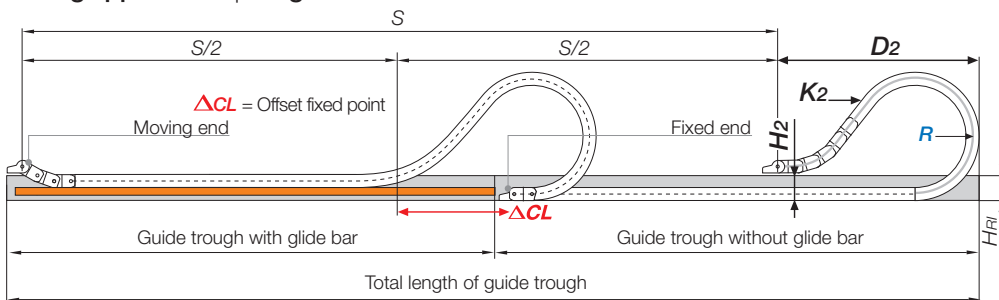

**Note:** For for long travel applications with more than 100 m we recommend to realize the engineering of such a plant by our technicians. In case of travels between 9 and 12 m we recommend a longer unsupported length. **Chain length**  $S/2 + K_2$

$R$	150*	200	250	300	350	400	500	600 <sup>1)</sup>
$H_2$	242	242	242	242	242	242	242	–
$D_2^{+25}$	550	800	950	1200	1550	1700	2175	–
$K_2$	910	1274	1638	2002	2457	2730	3458	–
$\Delta CL$	209	409	509	709	1009	1109	1484	–

<sup>1)</sup>Radius not available for e-tubes <sup>1)</sup> R600 not suitable for long travel applications. Please consult igus®

# E4/light | 15050·15150·R19850 | Accessories

## KMA mounting brackets | Attachment on all sides | pivoting | locking

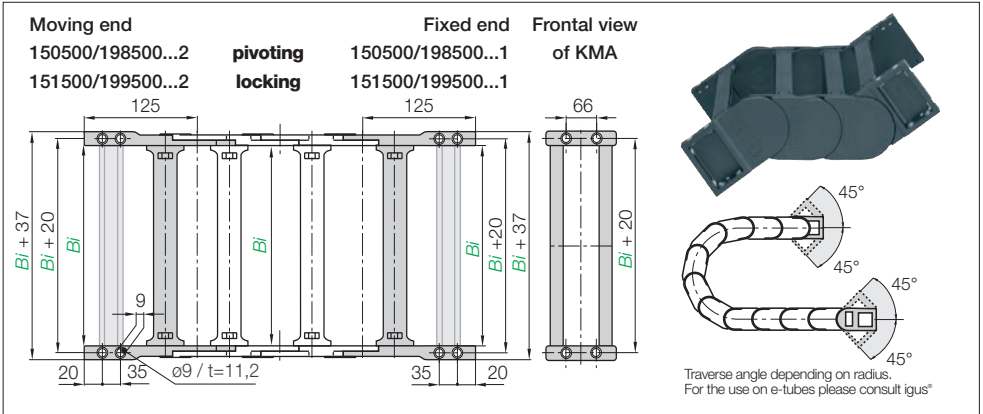

**KMA pivoting | Standard | Recommended for unsupported and gliding applications**  
**KMA locking | Recommended for vertical hanging and standing applications**

Width Index	Standard	Part No. full set KMA pivoting:	Part No. full set KMA locking:	Bi [mm]	Width Index	Standard	Part No. full set KMA pivoting:	Part No. full set KMA locking:	Bi [mm]
05.▶		150500. -	05.12.C 151500. -	05.12.C 50	31.▶		146500. -	31.12.C 151500. -	31.12.C 312
06.▶		150500. -	06.12.C 151500. -	06.12.C 65	32.▶		146500. -	32.12.C 151500. -	32.12.C 325
07.▶		150500. 198500.	07.12.C 151500. 199500.	07.12.C 75	33.▶		146500. -	33.12.C 151500. -	33.12.C 337
08.▶		150500. -	08.12.C 151500. -	08.12.C 87	35.▶		146500. 198500.	35.12.C 151500. 199500.	35.12.C 350
10.▶		150500. 198500.	10.12.C 151500. 199500.	10.12.C 100	36.▶		146500. -	36.12.C 151500. -	36.12.C 362
11.▶		150500. -	11.12.C 151500. -	11.12.C 112	37.▶		146500. -	37.12.C 151500. -	37.12.C 375
12.▶		150500. 198500.	12.12.C 151500. 199500.	12.12.C 125	38.▶		146500. -	38.12.C 151500. -	38.12.C 387
13.▶		150500. -	13.12.C 151500. -	13.12.C 137	40.▶		146500. 198500.	40.12.C 151500. 199500.	40.12.C 400
15.▶		150500. 198500.	15.12.C 151500. 199500.	15.12.C 150	41.▶		146500. -	41.12.C 151500. -	41.12.C 412
16.▶		150500. -	16.12.C 151500. -	16.12.C 162	42.▶		146500. -	42.12.C 151500. -	42.12.C 425
17.▶		150500. 198500.	17.12.C 151500. 199500.	17.12.C 175	43.▶		146500. -	43.12.C 151500. -	43.12.C 437
18.▶		150500. -	18.12.C 151500. -	18.12.C 187	45.▶		146500. -	45.12.C 151500. -	45.12.C 450
20.▶		150500. 198500.	20.12.C 151500. 199500.	20.12.C 200	46.▶		146500. 198500.	46.12.C 151500. 199500.	46.12.C 462
21.▶		150500. -	21.12.C 151500. -	21.12.C 212	47.▶		146500. -	47.12.C 151500. -	47.12.C 475
22.▶		150500. -	22.12.C 151500. -	22.12.C 225	48.▶		146500. -	48.12.C 151500. -	48.12.C 487
23.▶		150500. -	23.12.C 151500. -	23.12.C 237	50.▶		146500. -	50.12.C 151500. -	50.12.C 500
25.▶		150500. 198500.	25.12.C 151500. 199500.	25.12.C 250	51.▶		146500. -	51.12.C 151500. -	51.12.C 512
26.▶		150500. -	26.12.C 151500. -	26.12.C 262	52.▶		146500. -	52.12.C 151500. -	52.12.C 525
27.▶		150500. 198500.	27.12.C 151500. 199500.	27.12.C 275	53.▶		146500. -	53.12.C 151500. -	53.12.C 537
28.▶		150500. -	28.12.C 151500. -	28.12.C 287	55.▶		146500. -	55.12.C 151500. -	55.12.C 550
30.▶		150500. 198500.	30.12.C 151500. 199500.	30.12.C 300	60.▶		146500. -	60.12.C 151500. -	60.12.C 600

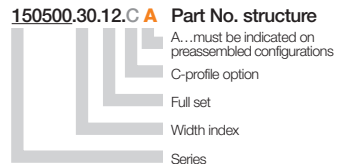
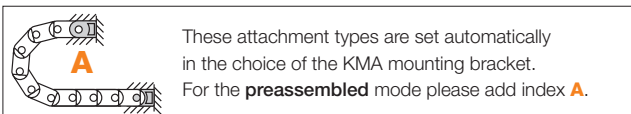

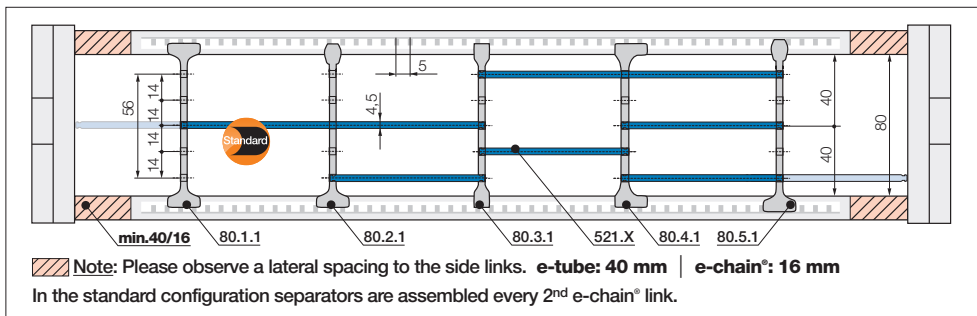
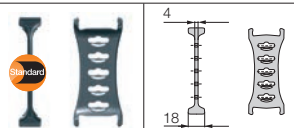



**Standard separator, wide base**

unassembled	80.1
assembled	80.1.1

### Standard - for all applications

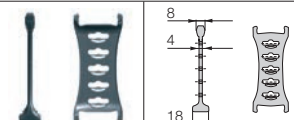
Separator with a wide base for maximum locking strength and safe standing in e-chains\* and e-tubes.



**Separator for QuickLock crossbar**

unassembled	80.2
assembled	80.2.1

### For even faster installation

Separator for igus® QuickLock crossbar 450.X.Q. Firm hold to one side with a wide base, narrow on opposed side for easy cable assembly (slight grip). For e-tubes also.

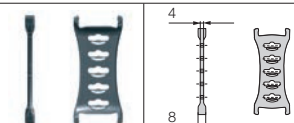

**Separator, narrow base**

unassembled	80.3
assembled	80.3.1

### For many thin cables

Separator with a narrow base for a large number of thin cables side by side. Saves space in e-chains\* and e-tubes. Also available for QuickLock crossbars.

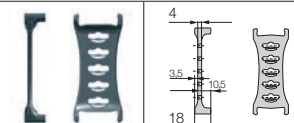

**Separator, asymmetrical**

unassembled	804
assembled	80.4.1

### For side-mounted applications

Asymmetrical separator, for defined distance. No additional spacers necessary for e-chains\* and e-tubes.

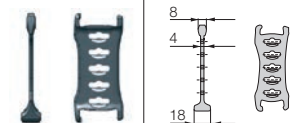

**Notch separator for notch crossbar**

unassembled	80.5
assembled	80.5.1

### Locks safely in 5 mm increments

Notch separator for the new notch crossbar, with scaling on the notch crossbars. For exact positioning in e-chains\* and e-tubes. Recommended for side-mounted applications.

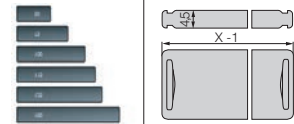

**Full-width shelf, lockable**

unassembled	520.X
assembled	521.X

### Horizontal separation

Shelf locks safely into separators on both ends, fixed width possible. Separators can be moved freely over the shelf in horizontal direction. Can be arranged at 5 different heights.

### Lockable full-width shelves



Width X [mm]	unassembled	assembled	Width X [mm]	unassembled	assembled	Width X [mm]	unassembled	assembled
050	520.050	521.050	125	520.125	521.125	225	520.225	521.225
065	520.065	521.065	150	520.150	521.150	250	520.250	521.250
075	520.075	521.075	175	520.175	521.175	300	520.300	521.300
100	520.100	521.100	200	520.200	521.200	450	520.450	521.450

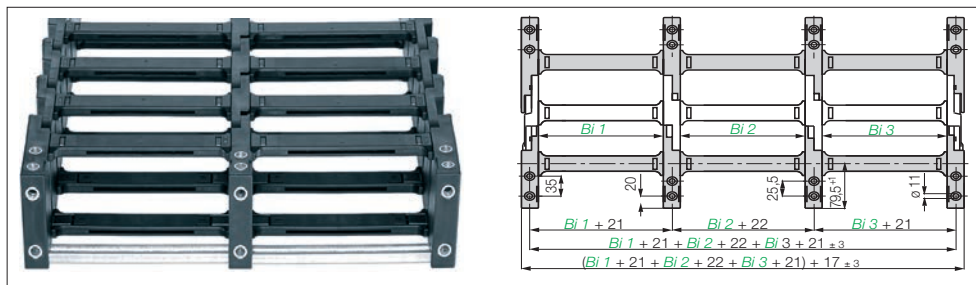

### Extension links | For extremely wide e-chains® up to 3,0 m

- Virtually limitless side-by-side attachment for high fill weights necessitate extremely wide e-chains® (up to 3000 mm)
- The unsupported length  $FL_G$  max. can be increased when additional loads are required

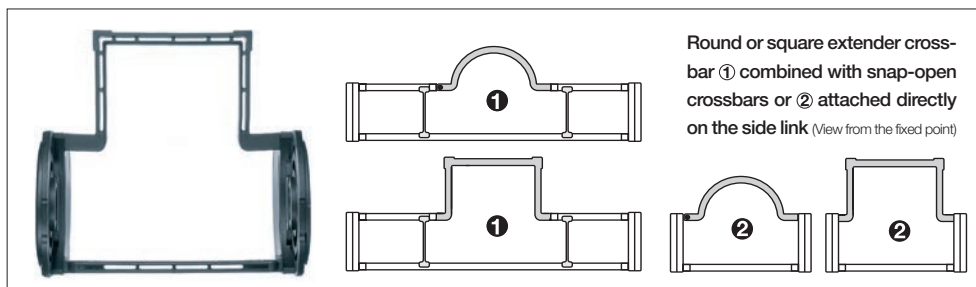

### Extender crossbars | Safe guiding for large hoses

- Suitable for hoses with a maximum outer diameter of 270 mm
- Gliding with crossbars assembled along outer radius and a special guide trough
- Extender crossbar ① for snap-open crossbars or ② attached directly on the side link

Part No. single part	Max Ø [mm] hose	Form	② Installation on side link	① Combination with snap-open crossbars
450.15.RHD115	115	○ round	no	yes
450.17.RD115	115	○ round	yes	no
450.25.D150	150	□ square	yes	no
450.30.D200	200	□ square	yes	no
450.35.D250	220	□ square	yes	no
450.40.D300	270	□ square	yes	no
450.20.HD150	150	□ square	no	yes
450.25.HD200	200	□ square	no	yes
450.30.HD250	220	□ square	no	yes



### E4 snapclip - clip-on cable binder

● For side-mounted applications ● Serves as a clip-on, lateral guide for hoses and cables on e-chains\* ● The loops can be adjusted as required ● Compatible with many E4 e-chains\* ● One clip and one locking band are needed for each e-chain\* link. **The complete range with order options ► [www.igus.eu/eu/15050](http://www.igus.eu/eu/15050)**

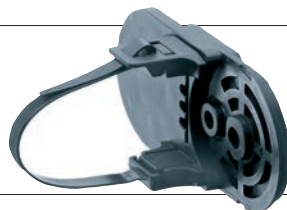

### The igus® e-chain® opener reduces assembly time

e-chain® opener tools for convenient opening and closing of E4 series igus® e-chains\* ● Especially for e-chains\* with many crossbars the assembly is much easier ● Especially in areas difficult to access mounting is simplified big savings in assembly time. Please call us or ► [www.igus.eu/eu/E4savetime](http://www.igus.eu/eu/E4savetime)



### Optional: Support tray tool kit.

#### For support of the lower run.

Simple one-piece support trays according to your requirements and specification. **The complete range with order options ► from page 714**

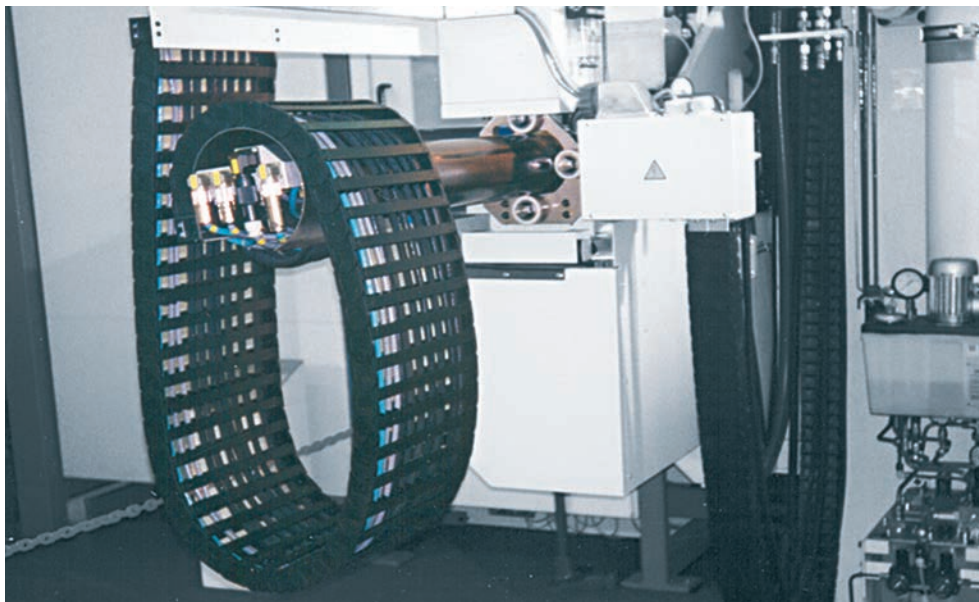

Circular movements (also with reverse bending radius "RBR") possible



e-chains® | Series 15250 crossbars every link (crossbars removable along both radii)

e-chains® | Series 15350 crossbars every 2<sup>nd</sup> link (crossbars removable along both radii)

Part No. e-chains <sup>®</sup>	<i>Bi</i> [mm]	<i>Ba</i> [mm]	15250 [kg/m]	15350 [kg/m]
15250.15350.05. <i>R.0</i>	50	80	≈ 3,64	≈ 3,56
15250.15350.06. <i>R.0</i>	68	98	≈ 3,72	≈ 3,60
15250.15350.07. <i>R.0</i>	75	105	≈ 3,74	≈ 3,61
15250.15350.087. <i>R.0</i>	87	117	≈ 3,79	≈ 3,63
15250.15350.097. <i>R.0</i>	97	127	≈ 3,83	≈ 3,65
15250.15350.10. <i>R.0</i>	100	130	≈ 3,85	≈ 3,66
15250.15350.11. <i>R.0</i>	108	138	≈ 3,87	≈ 3,67
15250.15350.112. <i>R.0</i>	112	143	≈ 3,88	≈ 3,68
15250.15350.12. <i>R.0</i>	125	155	≈ 3,95	≈ 3,71
15250.15350.137. <i>R.0</i>	137	167	≈ 3,98	≈ 3,73
15250.15350.15. <i>R.0</i>	150	180	≈ 4,04	≈ 3,75
15250.15350.162. <i>R.0</i>	162	193	≈ 4,06	≈ 3,76
15250.15350.17. <i>R.0</i>	168	198	≈ 4,11	≈ 3,79
15250.15350.18. <i>R.0</i>	175	205	≈ 4,12	≈ 3,80
15250.15350.187. <i>R.0</i>	187	218	≈ 4,15	≈ 3,81
15250.15350.20. <i>R.0</i>	200	230	≈ 4,23	≈ 3,85

Part No. e-chains <sup>®</sup>	<i>Bi</i> [mm]	<i>Ba</i> [mm]	15250 [kg/m]	15350 [kg/m]
15250.15350.212. <i>R.0</i>	212	243	≈ 4,26	≈ 3,86
15250.15350.23. <i>R.0</i>	225	255	≈ 4,32	≈ 3,89
15250.15350.237. <i>R.0</i>	237	268	≈ 4,34	≈ 3,90
15250.15350.25. <i>R.0</i>	250	280	≈ 4,42	≈ 3,94
15250.15350.262. <i>R.0</i>	262	293	≈ 4,47	≈ 3,97
15250.15350.28. <i>R.0</i>	275	305	≈ 4,51	≈ 3,99
15250.15350.29. <i>R.0</i>	287	318	≈ 4,53	≈ 4,00
15250.15350.30. <i>R.0</i>	300	330	≈ 4,61	≈ 4,04
15250.15350.312. <i>R.0</i>	312	343	≈ 4,63	≈ 4,05
15250.15350.325. <i>R.0</i>	325	355	≈ 4,69	≈ 4,08
15250.15350.337. <i>R.0</i>	337	368	≈ 4,73	≈ 4,10
15250.15350.350. <i>R.0</i>	350	380	≈ 4,87	≈ 4,17
15250.15350.362. <i>R.0</i>	362	393	≈ 4,92	≈ 4,20
15250.15350.375. <i>R.0</i>	375	405	≈ 4,97	≈ 4,22
15250.15350.387. <i>R.0</i>	387	418	≈ 5,01	≈ 4,24
15250.15350.400. <i>R.0</i>	400	430	≈ 5,05	≈ 4,26

<sup>1)</sup> Removable lid only, no hinged option

Available bending radii *R* [mm] 150 | 200 | 250 | 300 | 350 | 400 | 500 | 600

Supplement Part No. with required radius (*R*). Examples:

15250.20.300.0 = e-chain® with crossbars every link, inner width *Bi* 200 mm, radius *R* 300 mm, color black

15350.20.300.0 = e-chain® with crossbars every 2<sup>nd</sup> link, inner width *Bi* 200 mm, radius *R* 300 mm, color black



## Unsupported applications | Short travels

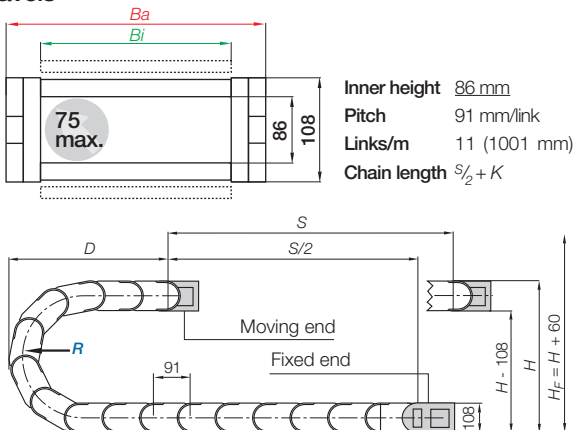
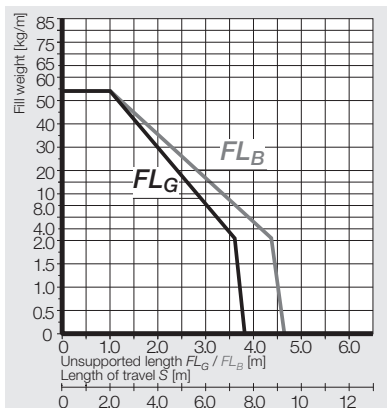

	R 150	200	250	300	350	400	500	600
$H_{+25}^0$	408	508	608	708	808	908	1108	1308
D	341	391	441	491	541	591	691	791
K	655	815	970	1125	1285	1440	1755	2070

The required clearance height:  $H_F = H + 60$  mm (with 3,0 kg/m fill weight)

## Gliding applications | Long travels from 12 m to max. 250 m

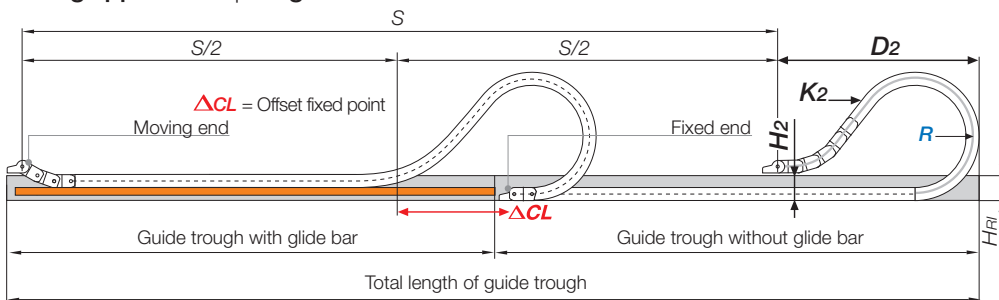

**Note:** For long travel applications with more than 100 m we recommend to realize the engineering of such a plant by our technicians. In case of travels between 9 and 12 m we recommend a longer unsupported length. **Chain length**  $S/2 + K_2$

	R 150	200	250	300	350	400	500	600*
$H_2$	242	242	242	242	242	242	242	*
$D_2+25$	550	800	950	1200	1550	1700	2175	*
$K_2$	910	1274	1638	2002	2457	2730	3458	*
$\Delta CL$	209	409	509	709	1009	1109	1339	*

\*R600 not suitable for long travel applications. Please consult igus®

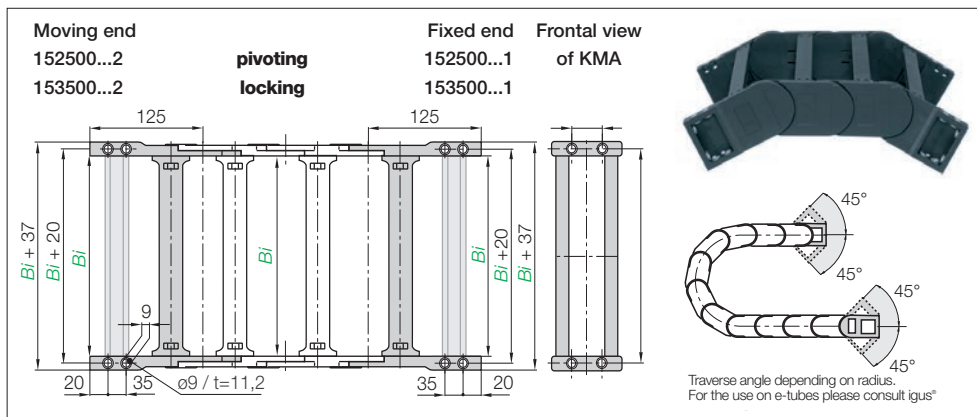

**KMA pivoting** | Standard | Recommended for unsupported and gliding applications  
**KMA locking** | Recommended for vertical hanging and standing applications

Width Index	Standard	Part No. full set KMA pivoting:	Part No. full set KMA locking:	Bi [mm]	Width Index	Standard	Part No. full set KMA pivoting:	Part No. full set KMA locking:	Bi [mm]
.05	▶	152500.05. 12.C	153500.05. 12.C	50	.212	▶	152500.212.12.C	153500.212.12.C	212
.06	▶	152500.06. 12.C	153500.06. 12.C	65	.23	▶	152500.23. 12.C	153500.23. 12.C	225
.07	▶	152500.07. 12.C	153500.07. 12.C	75	.237	▶	152500.237.12.C	153500.237.12.C	237
.087	▶	152500.087.12.C	153500.087.12.C	87	.25	▶	152500.25. 12.C	153500.25. 12.C	250
.09	▶	152500.09. 12.C	153500.09. 12.C	97	.262	▶	152500.262.12.C	153500.262.12.C	262
.10	▶	152500.10. 12.C	153500.10. 12.C	100	.28	▶	152500.28. 12.C	153500.28. 12.C	275
.11	▶	152500.11. 12.C	153500.11. 12.C	108	.29	▶	152500.29. 12.C	153500.29. 12.C	287
.112	▶	152500.112.12.C	153500.112.12.C	112	.30	▶	152500.30. 12.C	153500.30. 12.C	300
.12	▶	152500.12. 12.C	153500.12. 12.C	125	.312	▶	152500.312.12.C	153500.312.12.C	312
.137	▶	152500.137.12.C	153500.137.12.C	137	.325	▶	152500.325.12.C	153500.325.12.C	325
.15	▶	152500.15. 12.C	153500.15. 12.C	150	.337	▶	152500.337.12.C	153500.337.12.C	337
.162	▶	152500.162.12.C	153500.162.12.C	162	.350	▶	152500.350.12.C	153500.350.12.C	350
.17	▶	152500.17. 12.C	153500.17. 12.C	168	.362	▶	152500.362.12.C	153500.362.12.C	362
.18	▶	152500.18. 12.C	153500.18. 12.C	175	.375	▶	152500.375.12.C	153500.375.12.C	375
.187	▶	152500.187.12.C	153500.187.12.C	187	.387	▶	152500.387.12.C	153500.387.12.C	387
.20	▶	152500.20. 12.C	153500.20. 12.C	200	.400	▶	152500.400.12.C	153500.400.12.C	400

**152500.20.12.C A** Part No. structure  
 A... must be indicated on preassembled configurations  
 C-profile option  
 Full set  
 Width index  
 Series

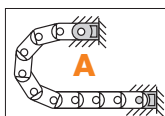

These attachment types are set automatically in the choice of the KMA mounting bracket.  
 For the **preassembled** mode please add index **A**.

**Strain relief** e.g. clamps, tiewrap plates, nuggets and plug-in clips are available from stock. The complete chainfix range with order options ▶ from page 630

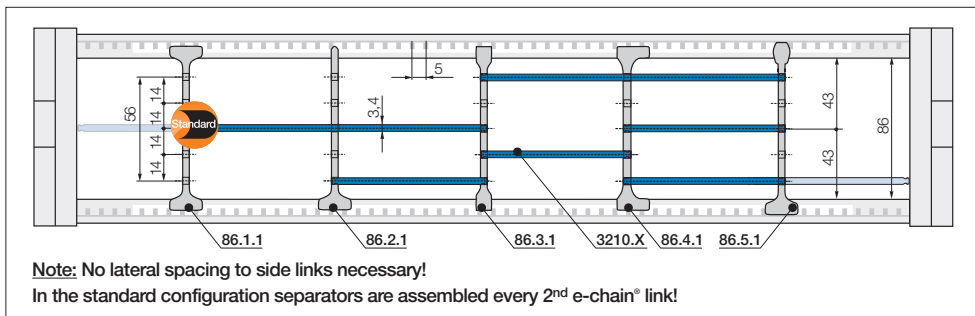
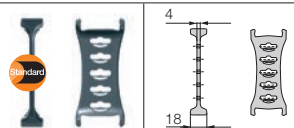



**Standard separator, wide base**

unassembled	<b>86.1</b>
assembled	<b>86.1.1</b>

### Standard - for all applications

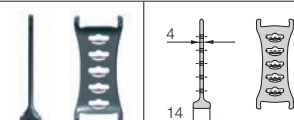
Separator with a wide base for maximum locking strength and safe standing in e-chains®.



**Separator for QuickLock crossbar**

unassembled	<b>86.2</b>
assembled	<b>86.2.1</b>

### For even faster installation

Separator for igus® QuickLock crossbar 385.X.Q. Firm hold to one side with a wide base, narrow on opposed side for easy cable assembly (slight grip).

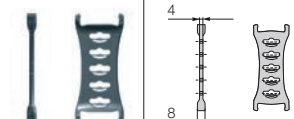

**Separator, narrow base**

unassembled	<b>86.3</b>
assembled	<b>86.3.1</b>

### For many thin cables

Separator with a narrow base for a large number of thin cables side by side. Saves space in e-chains®. Also available for QuickLock crossbars.

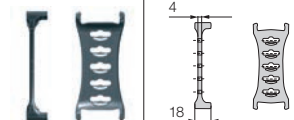

**Separator, asymmetrical\***

unassembled	<b>86.4</b>
assembled	<b>86.4.1</b>

### For side-mounted applications

Asymmetrical separator, for defined distance. No additional spacers necessary for e-chains®.

\*Available upon request, please consult igus® for delivery time

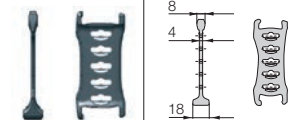

**Notch separator for notch crossbar**

unassembled	<b>86.5</b>
assembled	<b>86.5.1</b>

### Locks safely in 5 mm increments

Notch separator for the new notch crossbar, with scaling on the notch crossbars. For exact positioning in e-chains®. Recommended for side-mounted applications.

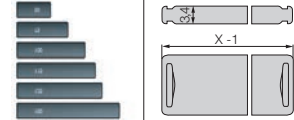

**Full-width shelf, lockable**

unassembled	<b>3200.X</b>
assembled	<b>3210.X</b>

### Horizontal separation

Shelf locks safely into separators on both ends, fixed width possible. Separators can be moved freely over the shelf in horizontal direction. Can be arranged at 5 different heights.

### Lockable full-width shelves



	Width X [mm]		Width X [mm]		Width X [mm]			
	unassembled	assembled	unassembled	assembled	unassembled	assembled		
050	3200.050	3210.050	125	3200.125	3210.125	225	3200.225	3210.225
075	3200.075	3210.075	150	3200.150	3210.150	250	3200.250	3210.250
100	3200.100	3210.100	175	3200.175	3210.175			
115	3200.115	3210.115	200	3200.200	3210.200			

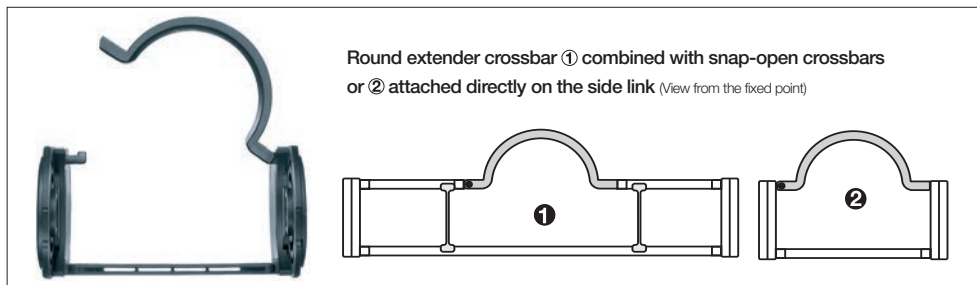

### Extender crossbars | Safe guiding for large hoses

- Suitable for hoses with a maximum outer diameter of 115 mm
- Gliding with crossbars assembled along outer radius and a special guide trough
- Extender crossbar ① for snap-open crossbars or ② attached directly on the side link

Part No. single part	Max Ø [mm] hose	Form	② Installation on side link	① Combination with snap-open crossbars
385.15.RHD115	115	○ round	no	yes
385.18.RD115	115	○ round	yes	no

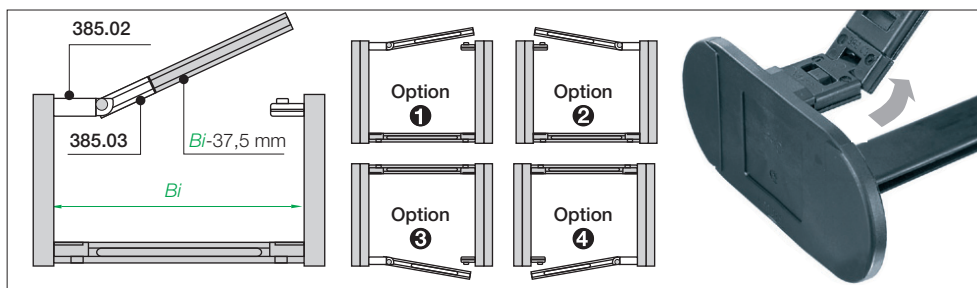

### Hinged crossbars | When snap-open crossbars have to remain attached

- Please consult igus® for design assistance
- Hinged crossbar: Part No. 385.02
- Snap-open crossbar (shortened):  $Bi-37,5 \text{ mm}$  Part No. 385.03 (smallest inner width  $Bi = 87,5$ )

Optional: **Support tray tool kit.**

**For support of the lower run.**

Simple one-piece support trays according to your requirements and specification.  
The complete range with order options ► from page 714



System E4 e-chain® - can be filled with cables of diameters up to 100 mm

Stable due to undercut design, very large inner height

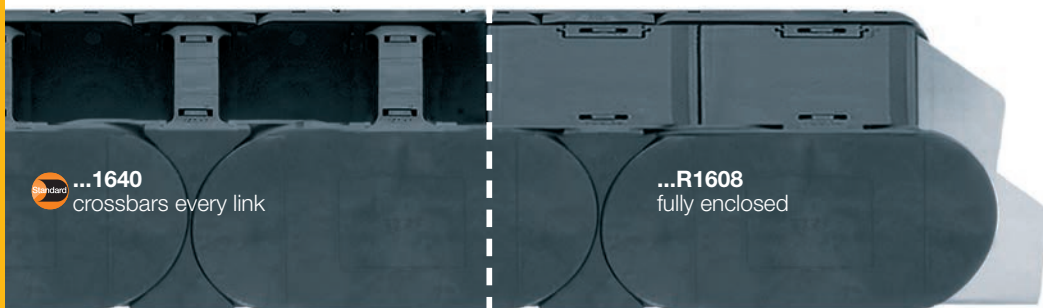

e-chains® | Series 1640 crossbars every link (crossbars removable along both radii)

e-tubes | Series R1608 fully enclosed (hinged snap-open removable lids along outer radius)

Part No. e-chains® / e-tubes	<i>Bi</i> [mm]	<i>Ba</i> [mm]	1640 [kg/m]	1608 [kg/m]
1640. – 05. R.0	50	84	≈5,10	–
1640. – 06. R.0	65	99	≈5,18	–
1640. – 07. R.0	75	109	≈5,27	–
1640. – 08. R.0	87	121	≈5,31	–
1640. – 10. R.0	100	134	≈5,36	–
1640. – 11. R.0	112	146	≈5,45	–
1640. – 12. R.0	125	159	≈5,54	–
1640. – 13. R.0	137	171	≈5,63	–
1640. – 15. R.0	150	184	≈5,67	–
1640. – 16. R.0	162	196	≈5,74	–
1640. – 17. R.0	175	209	≈5,81	–
1640. – 18. R.0	187	221	≈5,88	–
1640. 1608. 20. R.0	200	234	≈5,89	7,690
1640. – 21. R.0	212	246	≈5,96	–
1640. – 22. R.0	225	259	≈6,01	–
1640. – 23. R.0	237	271	≈6,09	–
1640. 1608. 25. R.0	250	284	≈6,15	8,390
1640. – 26. R.0	262	296	≈6,20	–
1640. – 27. R.0	275	309	≈6,27	–
1640. – 28. R.0	287	321	≈6,29	–
1640. 1608. 30. R.0	300	334	≈6,34	9,090

Part No. e-chains® / e-tubes	<i>Bi</i> [mm]	<i>Ba</i> [mm]	1640 [kg/m]	1608 [kg/m]
1640. – 31. R.0	312	346	≈6,41	–
1640. – 32. R.0	325	359	≈6,48	–
1640. – 33. R.0	337	371	≈6,59	–
1640. 1608. 35. R.0	350	384	≈6,61	9,790
1640. – 36. R.0	362	396	≈6,67	–
1640. – 37. R.0	375	409	≈6,71	–
1640. – 38. R.0	387	421	≈6,76	–
1640. 1608. 40. R.0	400	434	≈6,89	10,490
1640. – 41. R.0	412	446	≈6,99	–
1640. – 42. R.0	425	459	≈7,08	–
1640. – 43. R.0	437	471	≈7,13	–
1640. – 45. R.0	450	484	≈7,17	–
1640. – 46. R.0	462	496	≈7,18	–
1640. – 47. R.0	475	509	≈7,22	–
1640. – 48. R.0	487	521	≈7,27	–
1640. – 50. R.0	500	534	≈7,35	–
1640. – 51. R.0	512	546	≈7,36	–
1640. – 52. R.0	525	559	≈7,39	–
1640. – 53. R.0	537	571	≈7,49	–
1640. – 55. R.0	550	584	≈7,80	–
1640. – 60. R.0	600	634	≈7,92	–

\*Radius not available for e-tubes

Available bending radii *R* [mm] 200\* | 250 | 300 | 350 | 400 | 450 | 500 | 550 | 600Supplement Part No. with required radius (*R*). Examples:1640.30.300.0 = e-chain® with crossbars every link, inner width *Bi* 300 mm, radius *R* 300 mm, color black1608.30.300.0 = e-tube fully enclosed, inner width *Bi* 300 mm, radius *R* 300 mm, color black





## Unsupported applications | Short travels

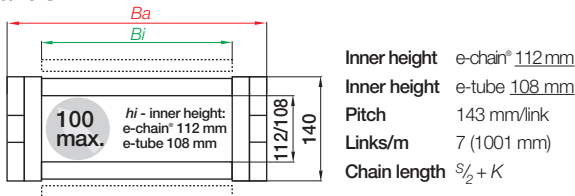
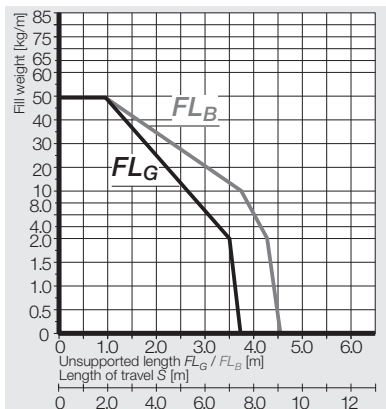

- Inner height e-chain® 112 mm
- Inner height e-tube 108 mm
- Pitch 143 mm/link
- Links/m 7 (1001 mm)
- Chain length  $S/2 + K$

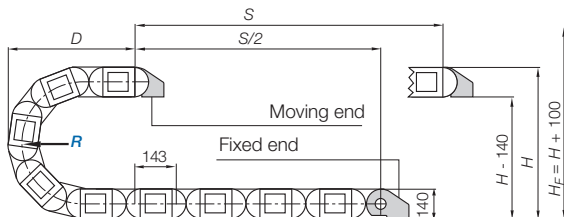

R	200*	250	300	350	400	450	500	550	600
H	540	640	740	840	940	1040	1140	1240	1340
D	485	535	585	635	685	735	785	835	885
K	915	1075	1230	1390	1545	1700	1860	2015	2175

The required clearance height:  $H_F = H + 100$  mm (with 5,0 kg/m fill weight)

\*Radius not available for e-tubes

## Gliding applications | Long travels from 14 m to max. 400 m

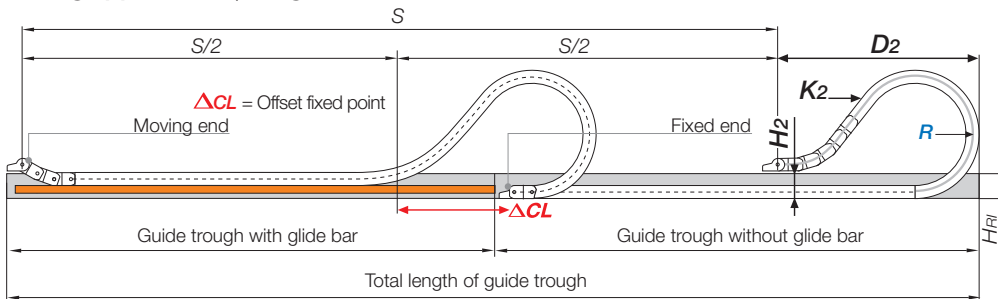

**Note:** For long travel applications with more than 100 m we recommend to realize the engineering of such a plant by our technicians. In case of travels between 9 and 14 m we recommend a longer unsupported length. **Chain length**  $S/2 + K_2$

R	200*	250	300	350	400	450	500	550	600
H <sub>2</sub>	325	325	325	325	325	325	325	325	325
D <sub>2</sub> +25	900	1000	1100	1250	1450	1600	1700	1900	2050
K <sub>2</sub>	1573	1716	1859	2288	2574	2860	3146	3432	3861
ΔCL	450	500	550	650	800	900	950	1100	1200

\*Radius not available for e-tubes

# E4/light | Series 1640·R1608 | Accessories

## Steel mounting brackets | pivoting

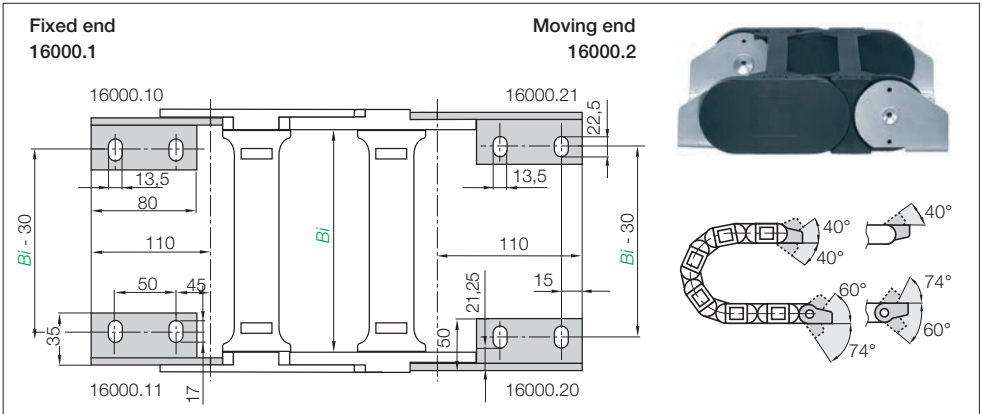

**Steel | Recommended for unsupported, gliding, vertical hanging, standing applications**

**16000.1.12.E** Full set (both sides) for e-chain®, ending with outer side link

**16000.3.12.E** Full set (both sides) for e-chain®, beginning with outer side link (moving end), ending with inner side link (fixed end)

**16000.1** Mounting bracket set **moving end** (one side) for outer side link

**16000.2** Mounting bracket set **fixed end** (one side) for inner side link

**Note:** By ordering steel mounting brackets in combination with an e-chain® / e-tube, they will be delivered assembled  
Stainless steel version available - please add index **.E** (Material: stainless steel 1.4301)

**Note:** Depending on the e-chain® length, the carrier will end with **1** outer or **3** inner side links. For the best appearance, make sure the e-chain® ends with **1** outer side link whenever possible. (with odd number of links)



**Strain relief** e.g. clamps, tie-wrap plates, nuggets and plug-in clips are available from stock. The complete chainfix range with order options ► from page 630

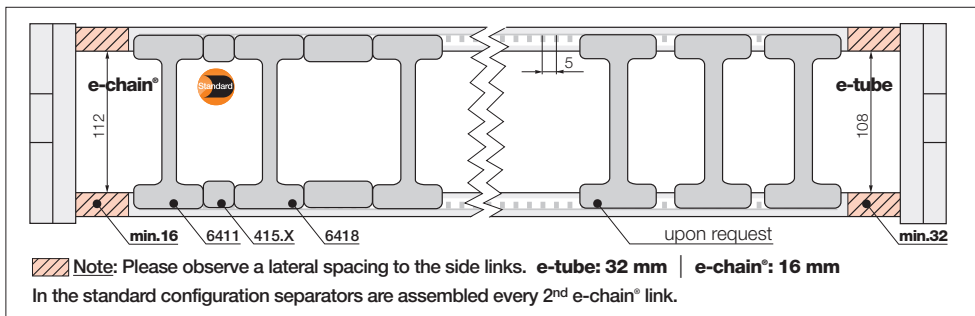

		<b>Separator for e-chains*</b> unassembled <b>6401</b> assembled <b>6411</b>
--	--	--

### Separator 6401 (e-chains\* only)

For a vertical subdivision. Offers safe stability due to its wide base design, also when used with thick cables or hoses (Separator for e-tubes 1608 upon request).

		<b>Locking separator for e-chains*</b> unassembled <b>6408</b> assembled <b>6418</b>
--	--	--

### Locking separator 6408 (e-chains\* only)

For applications exposed to very high humidity (> 85%). Locks with extra retention force. Tip: one locking separator per e-chain\* link for better mounting.

		<b>Spacer* for e-chains*</b> unassembled <b>405.XX</b> assembled <b>415.XX</b>
--	--	--

### Spacer\* 405.XX (e-chains\* only)

Separators can be fixed in position by spacers. The available interior height is reduced by 2 mm per spacer (4 mm when spacers are fitted on both sides). To avoid this, the parts can also be installed from the outside on the opening crossbar. (not for long travel applications). **XX = width of the spacer** (please choose between 10, 15, 20, 30, 40 mm).

		<b>Rollclip for e-chains*</b> unassembled <b>489.27</b> assembled <b>490.27</b>
--	--	---

### Additional elements - interior separation

#### Rollclip

Minimizes abrasion of particularly sensitive hoses - simply clamped onto the opening crossbar. The movable rollers compensate for relative movement between the e-chain\* and hose.

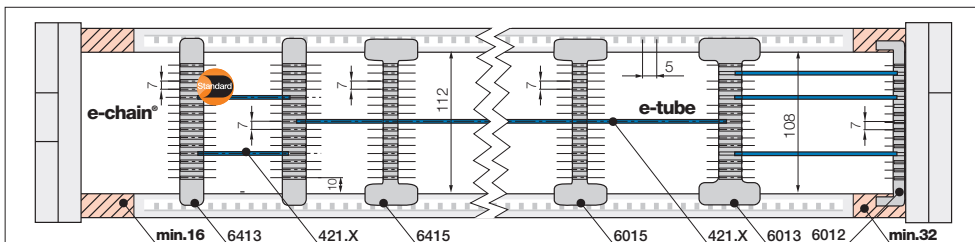

**Note:** Please observe a lateral spacing to the side links. **e-tube: 32 mm** | **e-chain: 16 mm**  
In the standard configuration separators are assembled every 2<sup>nd</sup> e-chain® link.

		<b>Open slotted separator for e-chains®</b>
		unassembled <b>6405</b>
		assembled <b>6415</b>

### Open, slotted separator 6405 (unilateral open)

Fast assembly - can be retrofitted into an existing interior separation system without a need for dismantling the interior separators. During an installation of open slotted separators, the top and bottom notches cannot be occupied by shelves. e-chains® only!

		<b>Open slotted separator for e-tubes</b>
		unassembled <b>6005</b>
		assembled <b>6015</b>

### Open, slotted separator 6005 (e-tubes only, unilateral open)

Works like open, slotted separator 6405 on e-tube 1608

		<b>Middle plate for e-chains®</b>
		unassembled <b>6403</b>
		assembled <b>6413</b>

### Middle plate 6403 (e-chains® only)

To achieve a modular shelving shelf 420.X can be arranged at 15 different heights (in 7 mm increments).

		<b>Middle plate for e-tubes</b>
		unassembled <b>6003</b>
		assembled <b>6013</b>

### Middle plate 6003 (e-tubes only)

Works like middle plate 6403 on e-tube 1608

		<b>Side plate for e-chains®/e-tubes</b>
		unassembled <b>6002</b>
		assembled <b>6012</b>

### Side plate 6002 (e-chains®/e-tubes)

Works like middle plate.  
Allows modular shelving close to the side links.

		<b>Shelf (18-149 mm)</b>
		unassembled <b>420.X</b>
		assembled <b>421.X</b>

### Shelf 420.X

For horizontal separation. Shelves of various widths can be arranged at 15 different heights (in 7 mm increments). - see table below.

### Shelves

Width X [mm]	unassembled	assembled	Width X [mm]	unassembled	assembled	Width X [mm]	unassembled	assembled
018	420.18	421.18	033	420.33	421.33	075	420.75	421.75
023	420.23	421.23	043	420.43	421.43	088	420.88	421.88
025	420.25	421.25	050	420.50	421.50	100	420.100	421.100
028	420.28	421.28	062	420.62	421.62	125	420.125	421.125

## Extension links | Extender crossbars

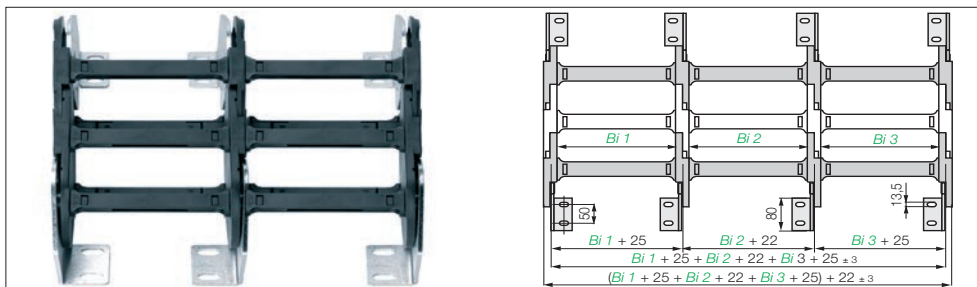

### Extension links | For extremely wide e-chains® up to 3,0 m

- Virtually limitless side-by-side attachment for high fill weights necessitate extremely wide e-chains® (up to 3000 mm)
- The unsupported length  $FL_G$  max. can be increased when additional loads are required

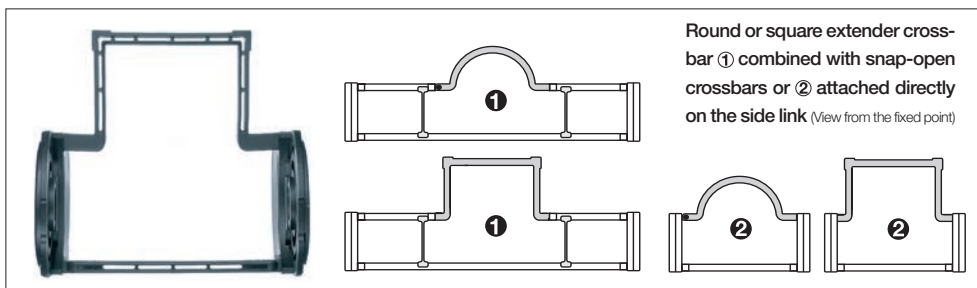

Round or square extender crossbar ① combined with snap-open crossbars or ② attached directly on the side link (View from the fixed point)

### Extender crossbars | Safe guiding for large hoses

- Suitable for hoses with a maximum outer diameter of 245 mm ● Gliding with crossbars assembled along outer radius and a special guide trough ● Extender crossbar ① for snap-open crossbars or ② attached directly on the side link

450.15.RHD115	115	○ round	no	yes
450.17.RD115	115	○ round	yes	no
450.25.D150	150	□ square	yes	no
450.30.D200	200	□ square	yes	no
450.35.D250	250	□ square	yes	no
450.40.D300	300	□ square	yes	no
450.20.HD150	150	□ square	no	yes
450.25.HD200	200	□ square	no	yes
450.30.HD250	250	□ square	no	yes

### E4 snapclip - clip-on cable binder

- For side-mounted applications ● Serves as a clip-on, lateral guide for hoses and cables on e-chains® ● The loops can be adjusted as required ● Compatible with many E4 e-chains® ● One clip and one locking band are needed for each e-chain® link. The complete range with order options ► [www.igus.eu/eu/1640](http://www.igus.eu/eu/1640)

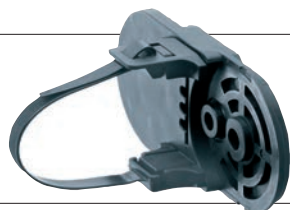

Universal:  
Mounting angles and  
strain relief option

Smooth running:  
Extremely low noise and low  
vibration due small pitch

Modular design:  
T-band in one piece  
of 8 chain links

Flexible:  
Easy shortening  
and lengthening

Clean:  
Hardly any abrasion, suitable  
for clean room applications

Easy to use:  
Clip-on "interior  
separation clips"

Dynamic:  
For high speed and  
high accelerations

Efficient:  
Very low weight

# Highly flexible, low-vibration T-band e-chain®

The E3-System combines low-noise operation, low sound level, simple installation and economy. The side plates, which can be snapped together, replace the conventional pin and bore connection and prevent relative movements between the joints, giving an almost complete freedom from wear. By the novel geometrical shape of the T-band, hardly any polygon effect is generated in operation. The T-band operates in a very smooth arc, giving extremely low vibration and noise. In order to reduce the manufacturing and installation costs, the T-band is mounted in a length of 8 chain links. Due to its low mass, the igus® T-band, combined with high speeds and accelerations, is suitable for applications with low fill weights and short strokes.

## Typical industries and applications

- Printer and plotter
- Clean room applications
- Production and processing of semiconductors
- Optics
- Automatic insertion machines
- Measuring technology

**Clean-Room** Clean room test upon request



igus® tests at 1 m measuring distance: = 33 dB(A) for T3.29.050.038.0 at v = 1 m/s und 26.5 dB(A) basic sound level



# T3 | Selection Table

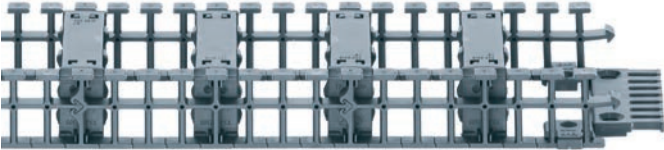



Series	Inner height <i>hi</i> [mm]	Inner width <i>Bi</i> [mm]	Outer width <i>Ba</i> [mm]	Outer height <i>ha</i> [mm]	Bending radius <i>R</i> [mm]	Unsupported max. length [m]	Page
							
<p><b>System T3 -</b> 3-piece, T-shaped band e-chains®</p>							
T3.29.	29	30 - 140	55 - 165	35	038	≈ 1,45	480

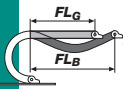

Circle movements with the T3 system. "RBR-Modul" from stock

## Technical Data



	Speed / acceleration $FL_G$ max.	max. 20 [m/s] / max. 200 [m/s <sup>2</sup> ]
	Speed / acceleration $FL_B$ max.	max. 3 [m/s] / max. 6 [m/s <sup>2</sup> ]
	Permitted temperature °C	-40° up to +70° C
	Flammability class	VDE 0304 IIC UL94-HB

■  $FL_G$  = with straight upper run ■  $FL_B$  = with permitted sag

### T3 e-chains® and modules for circular movement

T3 e-chains® for reverse bending radii (RBR) ● Several reverse bending radii ● Quiet ● Low wear ● Several mounting positions ● Complete program of interior separation of Series T3.29 ● RBR: 55, 75, 100, 150. **Part No. T3.29.050.38/55, T3.29.050.38/75, T3.29.050.38/100, T3.29.050.38/150.** Delivery time upon request. **Further Information ► [www.igus.eu/eu/circularmovement](http://www.igus.eu/eu/circularmovement)**



### T3 RBR-module for reverse bending radii



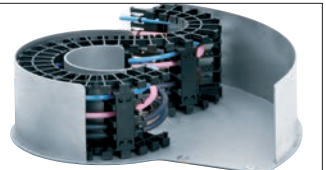





Consists of 4 elements: T3 RBR e-chain®, guiding system, chainflex®-cables, iglidur® PRT slewing ring bearing. ● Compact guiding module ● Turnable in inner and outer radius ● For high speeds, quiet ● Compact dimensions ● Several mounting positions. **Part No. T3.29.070.038/055.** Delivery time upon request. **Further Information ► [www.igus.eu/eu/circularmovement](http://www.igus.eu/eu/circularmovement)**





# T3 | Order keys and Options

## Options with order keys based on Series T3.29

 <p><i>Standard</i></p> <p>Part No. <b>Standard e-chains®</b></p> 	<p><i>NC-Version - (no camber) without pretension</i></p> <p>Part No. <b>NC-Version e-chains®</b></p> 	<p><i>Reverse bending radius for circular movements</i></p> <p>Part No. <b>RBR* e-chains®</b></p> 	<p><i>ESD / ATEX classified e-chains®</i></p>  <p>Part No. <b>ESD-Material e-chains®</b></p> 
 <p><b>T3.29.050.R.0</b></p>	<p><b>T3.29.050.R.0.NC</b></p>	<p><b>T3.29.050.R1/R2.0</b></p> <p><small>*RBR possible with igus® T3 RBR e-chains® or T3 RBR module ▶ <a href="http://www.igus.eu/eu/circularmovement">www.igus.eu/eu/circularmovement</a></small></p>	<p><b>T3.29.050.R.0.ESD</b></p>
 <p><b>Delivery from stock</b></p>	<p><b>Delivery time: upon request</b></p>	<p><b>Delivery time: upon request</b></p>	<p><b>Delivery time: upon request</b></p>

## Order example | Order key and color options based on Series T3.29

 **Order example for complete e-chain® (1,0 m), color black, with mounting angles and interior separation:**

e-chain® (1,0 m)	Please indicate e-chain® length or number of links: 1,0 m or 67 links	<b>T3.29.050.038.0</b>
+ Mounting brackets	1 set (strain relief for both sides + 2 mounting angles)	<b>T3.29.050.12</b>
+ Interior separation	with 2 separators assembled every 4 <sup>th</sup> link	<b>2 x E6.29.11</b>

Order text: 1,0 m T3.29.050.038.0 + T3.29.050.12 + 2 x E6.29.11

### Order key

T-shaped band e-chains® **T3.29.050.038.0**

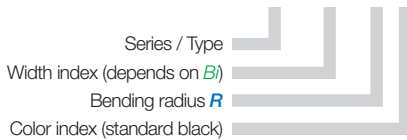

**T3.29.050.038.0** = with crossbars every 2<sup>nd</sup> link  
inner width *B* 50 mm, radius *R* 38 mm, color black

### General igus® color options for e-chains® and e-tubes

Color	Order index	Color	Order index
<b>Black</b> Standard, from stock!	<b>.0</b>	<b>White</b> special color	<b>.1</b>
<b>ESD metallic-grey</b>	<b>.ESD</b>	<b>Gray white</b> special color	<b>.1S</b>
<b>Gray brown</b> only HT material	<b>.HT</b>	<b>Orange</b> special color	<b>.2</b>
<b>Gray</b> special color only e-chains®	<b>.3</b>	<b>Yellow</b> special color	<b>.4</b>
<b>Dusty grey</b> special color only e-tubes	<b>.31</b>	<b>Light grey</b> special color	<b>.14</b>

**Black e-chains® available from stock!**  
**Delivery time for special colors: upon request**

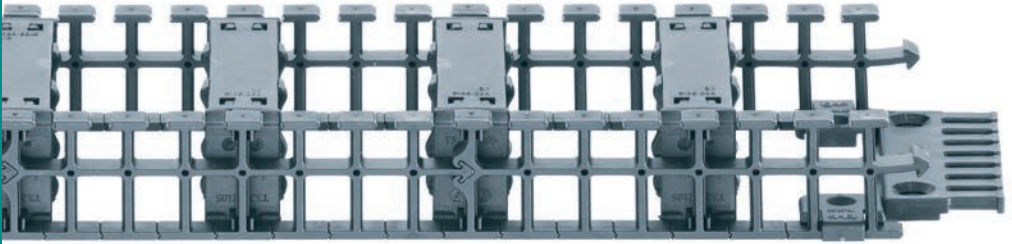

## Series T3.29 | 3-piece, T-shaped band e-chains®

e-chain® zip-open along outer radius	<i>Bi</i> [mm]	<i>Ba</i> [mm]	<i>R</i> Bending radii [mm]	Weight [kg/m]
T3.29. 030 .R.0	30	55	038	≈ 0,40
T3.29. 040 .R.0	40	65	038	≈ 0,42
T3.29. 050 .R.0	50	75	038	≈ 0,44
T3.29. 060 .R.0	60	85	038	≈ 0,46
T3.29. 070 .R.0	70	95	038	≈ 0,48
T3.29. 080 .R.0	80	105	038	≈ 0,50
T3.29. 090 .R.0	90	115	038	≈ 0,51
T3.29. 100 .R.0	100	125	038	≈ 0,53
T3.29. 110 .R.0	110	135	038	≈ 0,55
T3.29. 120 .R.0	120	145	038	≈ 0,57
T3.29. 140 .R.0	140	165	038	≈ 0,59

Supplement Part No. with required radius (*R*) Example: T3.29.100.038.0

## Dimensions

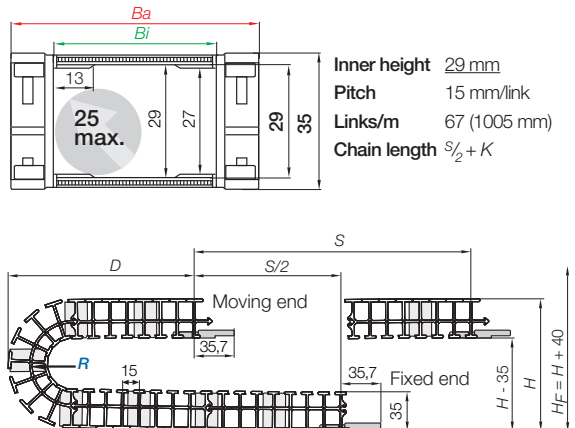
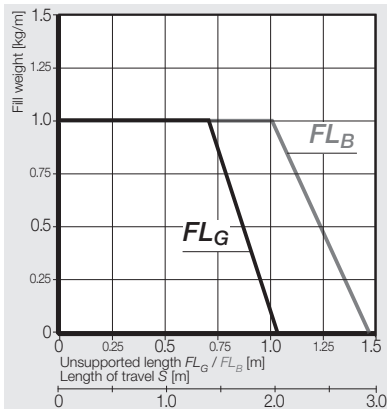

*R* (min.) 038

*H* (min.) 216

*D* 111

*K* 210

The required clearance height:  $H_F = H + 40$  mm (with 1,0 kg/m fill weight)

Plastic fastener | Mounting angle

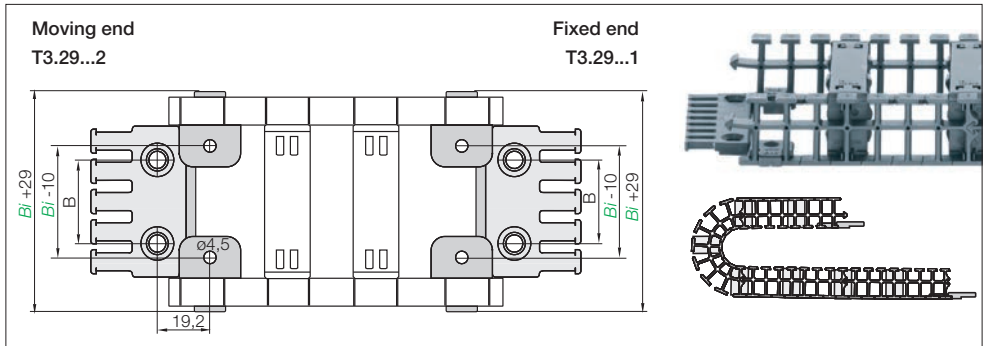

Width Index	Part No. full set:	Bi [mm]	Width Index	Part No. full set:	Bi [mm]
030. ▶	T3.29.030.12	30	090. ▶	T3.29.090.12	90
040. ▶	T3.29.040.12	40	100. ▶	T3.29.100.12	100
050. ▶	T3.29.050.12	50	110. ▶	T3.29.110.12	110
060. ▶	T3.29.060.12	60	120. ▶	T3.29.120.12	120
070. ▶	T3.29.070.12	70	140. ▶	T3.29.140.12	140
080. ▶	T3.29.080.12	80			

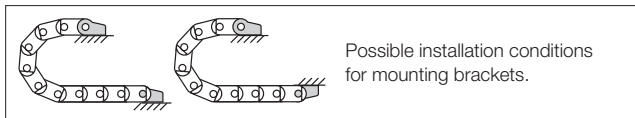

Part No. structure

T3.29.100.12

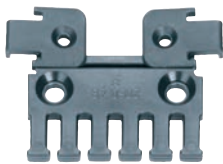

Mounting angle with strain relief



Mounting angle, single



**Strain relief** e.g. clamps, tiewrap plates, nuggets and plug-in clips are available from stock. The complete chainfix range with order options ▶ from page 630

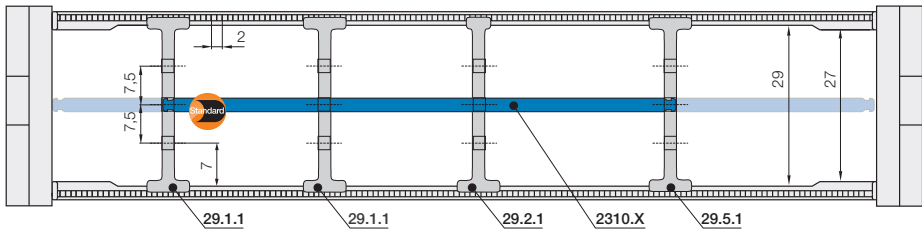

In the standard configuration separators are assembled every 2<sup>nd</sup> e-chain® link.

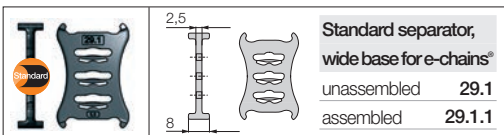

### Standard - for all applications

Separator with a wide base for maximum locking strength and safe standing in e-chains®.

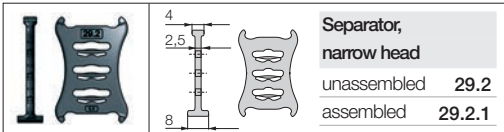

### For even faster installation

Firm hold to one side with a wide base, narrow on opposed side for easy cable assembly (slight grip).

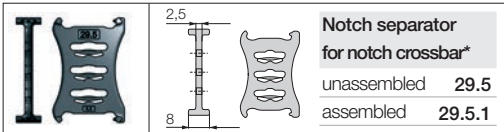

### Locks safely in 2 mm increments

Notch separator for exact positioning in e-chains®. Recommended for side-mounted applications.

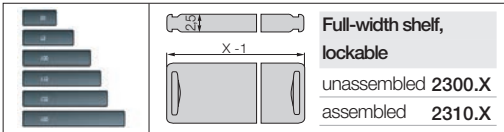

### Horizontal separation

Full-width shelf locks safely into separators on both ends, fixed width possible. Separators can be moved freely over the shelf in horizontal direction. Can be arranged at 3 different heights.

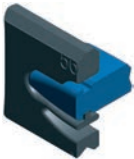

### Lockable full-width shelves

Width X [mm]	unassembled	assembled	Width X [mm]	unassembled	assembled	Width X [mm]	unassembled	assembled
015	2300.015	2310.015	060	2300.060	2310.060	087	2300.087	2310.087
025	2300.025	2310.025	062	2300.062	2310.062	090	2300.090	2310.090
030	2300.030	2310.030	065	2300.065	2310.065	100	2300.100	2310.100
038	2300.038	2310.038	070	2300.070	2310.070	103	2300.103	2310.103
040	2300.040	2310.040	075	2300.075	2310.075	110	2300.110	2310.110
050	2300.050	2310.050	077	2300.077	2310.077	120	2300.120	2310.120
057	2300.057	2310.057	080	2300.080	2310.080	125	2300.125	2310.125

## Separator with integrated strain relief

Strain relief separator Part No. E6.29.02.Z can be integrated into the mounting bracket and can be placed there at any point of the e-chain®. It combines strain relief and interior separation ● For the use in the first or last chain link ● Easy to assemble without any screws. **Further Information ▶ from page 650**

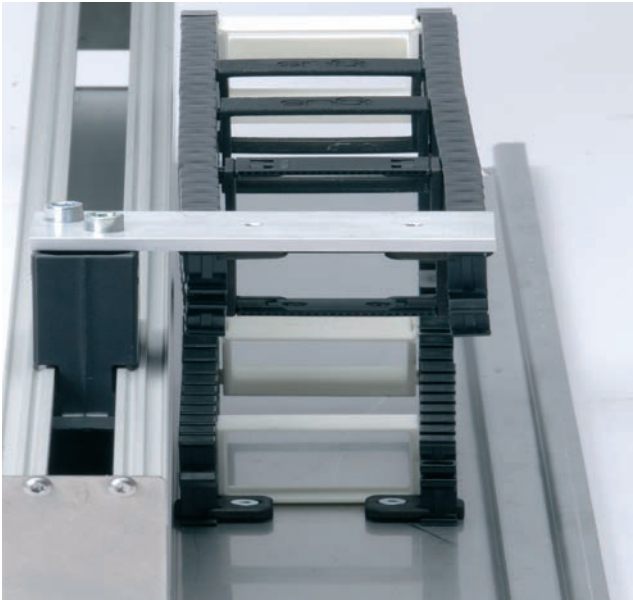

Testing facility at the igus® laboratory System T3 - ideal for high accelerations and short strokes

# Highly dynamic and clean room compatible

E3 combines small pitch, smooth running, low noise, easy assembly and cost efficiency all in one. The spring connector element replaces the pin and bore principle and avoids relative movements between the joints. This means virtually no wear or abrasion. To reduce production and assembling costs, the spring connector is not mounted individually, but on a length of ten e-chain® links. Another E3 option is safe performance. A modified spring element made of electrically conductive material, which connects the e-chain® links mechanically and electrically, permanently guarantees constant electrical conductance, even at high bending stress and in any position.

## Typical industries and applications

- Semi-conductor manufacturing and handling
- Pick and place robots ● Optics ● Materials handling technology ● Measuring technology
- Printers and plotters ● Clean room environments ● General mechanical engineering



IPA Qualification Certificate - Report IG0704-400: ISO Class 1, according to Norm DIN EN ISO 14644-1 for System E3, Series E3.15.040.075.0 at  $v = 0,5 \text{ m/s}$ ,  $1 \text{ m/s}$ ,  $2 \text{ m/s}$

 38 dB(A) - Value determined at the igus® test-lab acc. to DIN 45635, with consideration of background noises, E3.22.060.044.0 at  $v = 1,8 \text{ m/s}$

 Electrically conductive ESD/ATEX versions several Series available from stock

Universal:  
Mounting brackets and strain relief option

Smooth running:  
Small pitch for low-noise, smooth running

Flexible:  
Easy shortening and lengthening

Fast opening:  
zip-open mechanism along outer radius

Modular design:  
Crossbars, interior separation and links all in one band

Dynamic:  
For high speed and high accelerations

Clean room:  
Virtually no wear or abrasion



**iF product design award**  
2005 für igus® Serie E3.15



# E3 | Selection Table

Series	Inner height <i>hi</i> [mm]	Inner width <i>Bi</i> [mm]	Outer width <i>Ba</i> [mm]	Outer height <i>ha</i> [mm]	Bending radius <i>R</i> [mm]	Unsupported max. length [m]	Page
--------	--------------------------------	-------------------------------	-------------------------------	--------------------------------	---------------------------------	--------------------------------	------



**System E3 -  
3-piece e-chains®**  
zip-open along outer radius

<b>E3.10</b>	10	20 - 60	32 - 72	15	15 - 48	≈ 0,70	<b>488</b>
<b>E3.15</b>	15	20 - 60	32 - 72	20	32 - 75	≈ 0,90	<b>490</b>
<b>E3.22</b>	22	20 - 60	32 - 72	27	44 - 75	≈ 1,20	<b>492</b>



During long-term tests the System E3 with the spring band connector easily passes 15 million cycles at a bending radius of 44 mm and an acceleration of 4 g

## Technical Data

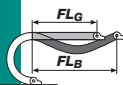

Speed / acceleration  $FL_G$  max. max. 20 [m/s] / max. 200 [m/s<sup>2</sup>]

Speed / acceleration  $FL_B$  max. max. 3 [m/s] / max. 6 [m/s<sup>2</sup>]



Permitted temperature °C -40° up to +70° C



Flammability class VDE 0304 IIC UL94-HB

■  $FL_G$  = with straight upper run ■  $FL_B$  = with permitted sag

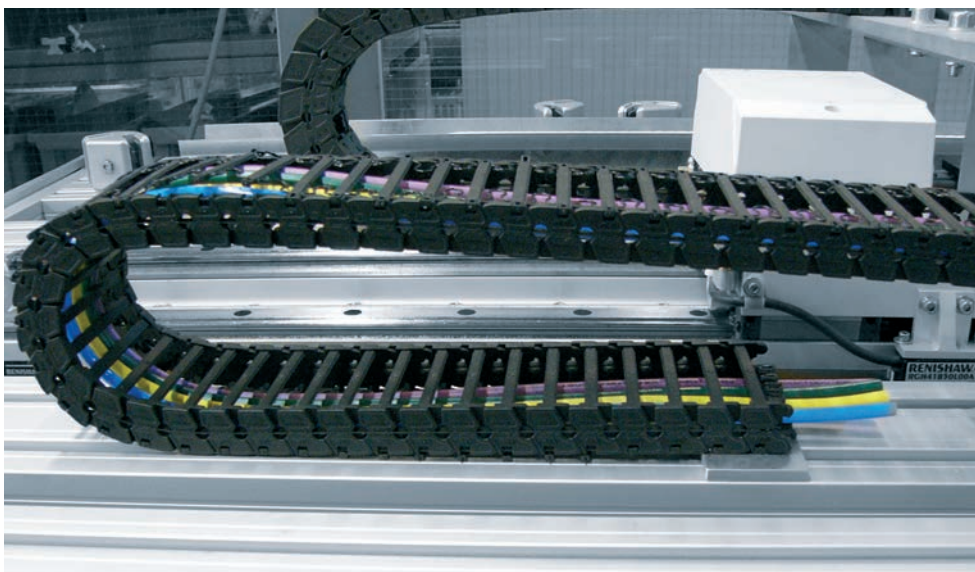







Long-term tests in our acoustics laboratory at a speed of 1.8 m/s and an acceleration of 3 m/s<sup>2</sup> showed reductions of 19-20 dB(A) compared to conventional e-chains®.



# E3 | Order keys and Options

## Options with order keys based on Series E3.10

<p> <i>Standard</i></p> <p>Part No. <b>Standard</b> e-chains®</p> 	<p><i>NC-Version - (no camber) without pretension</i></p> <p>Part No. <b>NC-Version</b> e-chains®</p> 	<p><i>ESD / ATEX classified e-chains®</i></p> <p> II 2 GD</p> <p>Part No. <b>ESD-Material</b> e-chains®</p> 
<p> <b>E3.10.060.R.0</b></p>	<p><b>E3.10.060.R.0.NC</b></p>	<p><b>E3.10.060.R.0.ESD</b></p>
<p> <b>Delivery from stock</b></p>	<p><b>Delivery time: upon request</b></p>	<p><b>Delivery time: upon request</b></p>

## Order example | Order key and color options based on Series E3.10

 **Order example for complete e-chain® (1,0 m), color black, with Mounting brackets and interior separation:**





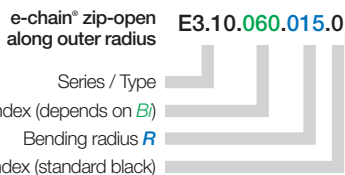





<b>e-chain® (1,0 m)</b>	Please indicate e-chain® length or number of links: 1,0 m or 60 links	<b>E3.10.060.015.0</b>
<b>+ Mounting brackets</b>	1 set (strain relief for both sides + 2 Mounting brackets)	<b>E3.10.060.12</b>
<b>+ Interior separation</b>	with 2 separators assembled every 2 <sup>nd</sup> link	<b>2 x E3.10.11</b>
<b>Order text: 1,0 m E3.10.060.015.0 + E3.10.060.12 + 2 x E3.10.11</b>		

### Order key



**E3.10.060.015.0** = e-chain® zip-open along outer radius, inner width *B* 60 mm, radius *R* 15 mm, color black

### General igus® color options for e-chains® and e-tubes

Color	Order index	Color	Order index
 <b>Black</b> Standard, from stock!	<b>.0</b>	 <b>White</b> special color	<b>.1</b>
 <b>ESD metallic-grey</b>	<b>.ESD</b>	 <b>Gray white</b> special color	<b>.1S</b>
 <b>Gray brown</b> only HT material	<b>.HT</b>	 <b>Orange</b> special color	<b>.2</b>
 <b>Gray</b> special color only e-chains®	<b>.3</b>	 <b>Yellow</b> special color	<b>.4</b>
 <b>Dusty grey</b> special color only e-tubes	<b>.31</b>	 <b>Light grey</b> special color	<b>.14</b>

**Black e-chains® available from stock!**  
**Delivery time for special colors: upon request**



## Series E3.10 | Zip-open along outer radius

e-chain* zip-open along outer radius	<i>Bi</i> [mm]	<i>Ba</i> [mm]	<i>R</i> Bending radii [mm]	Weight [kg/m]
E3.10. 020 .R.0	20	32	015   028   -   048*	≈ 0,12
E3.10. 040 .R.0	40	52	015   028*   038   048	≈ 0,15
E3.10. 060 .R.0	60	72	015   028*   038   048*	≈ 0,20

\*Radius available upon request, please consult igus\* for delivery time!

Supplement Part No. with required radius (*R*) Example: E3.10.060.015.0

## Dimensions

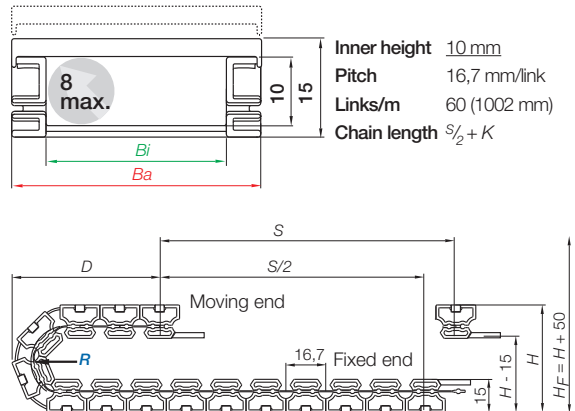
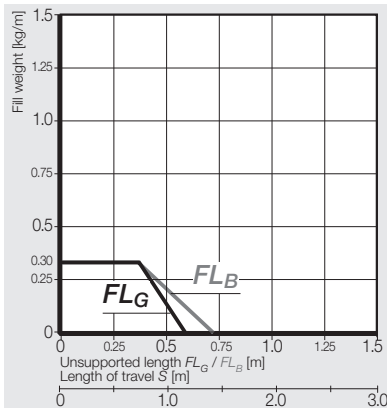

<i>R</i>	015	028	038	048
<i>H</i>	60	86	106	126
<i>D</i>	50	63	73	83
<i>K</i>	85	125	155	185

The required clearance height:  $H_F = H + 50$  mm (with 0,1 kg/m fill weight)

KMA mounting bracket | Mounting angle | polymer

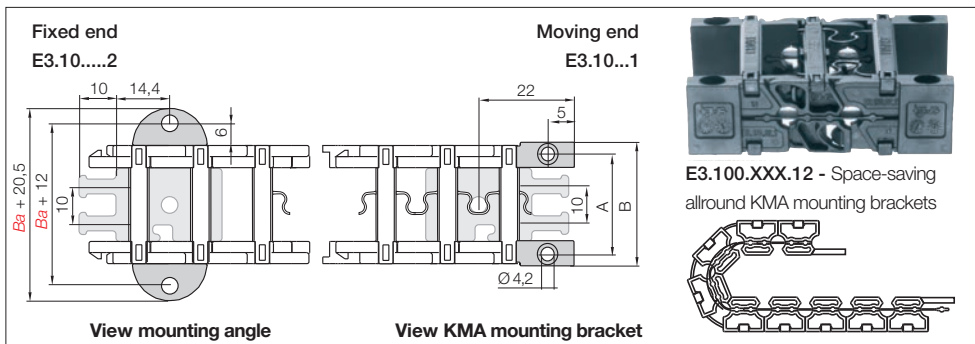

E3.100.XXX.12 - Space-saving allround KMA mounting brackets

Width Index	Part No. <b>New</b> in this catalog space-saving all-round KMA mounting bracket	Dim A [mm]	Dim B [mm]	Part No. full set mounting angle (single part)	Part No. strain relief for both sides	Part No. full set strain relief for both sides + 2 mounting angles
.020.	▶ E3.100.020.12	28	36	E3.10.00	E3.020.12	E3.10.020.12
.040.	▶ E3.100.040.12	48	56	E3.10.00	E3.040.12	E3.10.040.12
.060.	▶ E3.100.060.12	68	76	E3.10.00	E3.060.12	E3.10.060.12

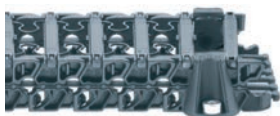

E3.100.XXX.12 - E3 with strain relief for both sides and mounting angles



E3.00.020 - Strain relief for both sides as single parts

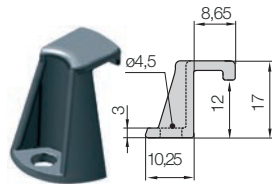
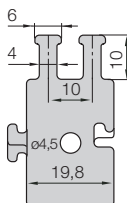

E3.10.00 - Mounting angle, single part

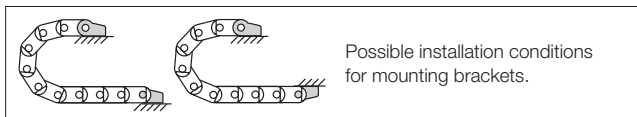

Possible installation conditions for mounting brackets.

Part No. structure

E3.10.040.12



Interior separation

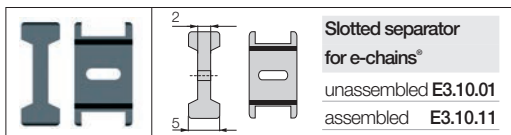

Slotted separator for e-chains®  
unassembled E3.10.01  
assembled E3.10.11

Slotted separator E3.10.01

Vertical separators are used if a vertical subdivision of the e-chain® interior is required.



## Series E3.15 | Zip-open along outer radius

e-chain* zip-open along outer radius	<i>Bi</i> [mm]	<i>Ba</i> [mm]	<i>R</i> Bending radii [mm]	Weight [kg/m]
E3.15. 020 .R.0	20	32	032   -   048*   -	≈ 0,22
E3.15. 040 .R.0	40	52	032   038   048   075	≈ 0,25
E3.15. 060 .R.0	60	72	032   038   048   075	≈ 0,32

\*Radius available upon request, please consult igus\* for delivery time!

Supplement Part No. with required radius (*R*) Example: E3.15.060.032.0

## Dimensions

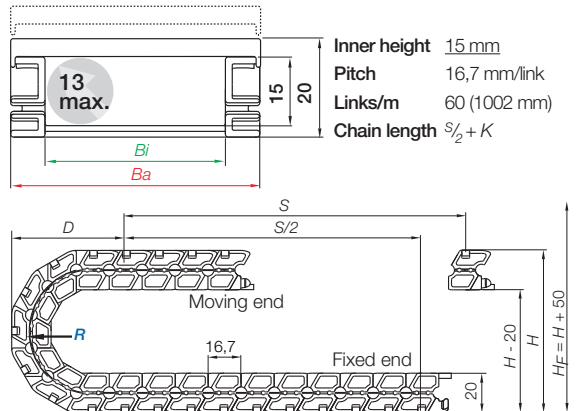
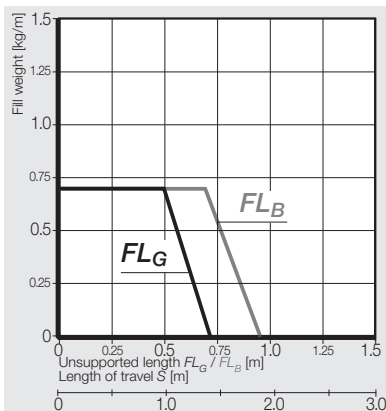

<i>R</i>	032	038	048	075
<i>H</i>	99	111	131	185
<i>D</i>	67	73	83	110
<i>K</i>	135	155	185	270

The required clearance height:  $H_F = H + 50$  mm (with 0,2 kg/m fill weight)

KMA mounting bracket | Mounting angle | polymer

**Fixed end**  
E3.15....2

**View mounting angle**

**Moving end**  
E3.15...1

**View KMA mounting bracket**

**E3.150.XXX.12** - Space-saving allround KMA mounting brackets

Width Index	Part No. <span style="color: red;">New</span> in this catalog space-saving all-round KMA mounting bracket	Dim A [mm]	Dim B [mm]	Part No. full set mounting angle (single part)	Part No. strain relief for both sides	Part No. full set strain relief for both sides + 2 mounting angles
.020.	▶ E3.150.020.12	28	36	E3.15.00	E3.020.12	E3.15.020.12
.040.	▶ E3.150.040.12	48	56	E3.15.00	E3.040.12	E3.15.040.12
.060.	▶ E3.150.060.12	68	76	E3.15.00	E3.060.12	E3.15.060.12

**E3.15.XXX.12** - E3 with strain relief for both sides and mounting angles

**E3.00.020** - Strain relief for both sides as single parts

**E3.15.00** - Mounting angle, single part

Possible installation conditions for mounting brackets.

**Part No. structure**

**E3.15.060.12**

- └── Full set
- └── Width index
- └── Series

**Interior separation**

**Slotted separator for e-chains®**

unassembled **E3.15.01**

assembled **E3.15.11**

**Slotted separator E3.15.01**

Vertical separators are used if a vertical subdivision of the e-chain® interior is required.

**Slotted separator on a strip E3.15.01.10**

unassembled **E3.15.01.10**

assembled **E3.15.11.10**

**Slotted separator on a strip E3.15.01.10**

Five vertical separators altogether on one strip over ten e-chain® links are mounted on the opening crossbars. In this way separate chambers are formed, protecting the cables. Dimensions same as E3.15.01.

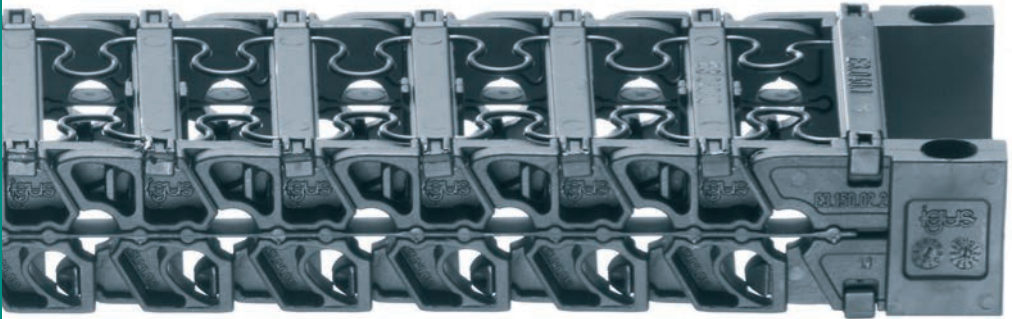

## Series E3.22 | Zip-open along outer radius

e-chain* zip-open along outer radius	<i>Bi</i> [mm]	<i>Ba</i> [mm]	<i>R</i> Bending radii [mm]	Weight [kg/m]
E3.22.020.R.0	20	32	044   050   075	≈ 0,30
E3.22.040.R.0	40	52	044   050   075	≈ 0,32
E3.22.060.R.0	60	72	044   -   075	≈ 0,41

Supplement Part No. with required radius (*R*) Example: E3.22.060.044.0

## Dimensions

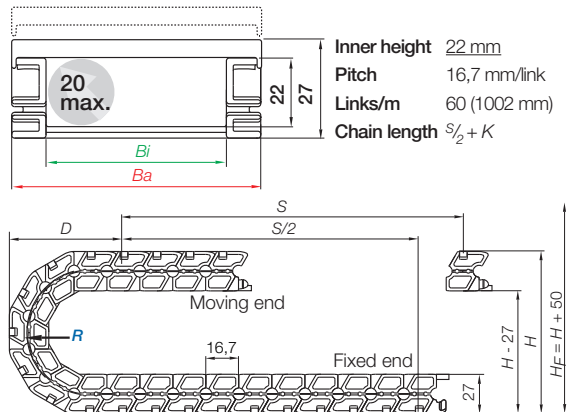
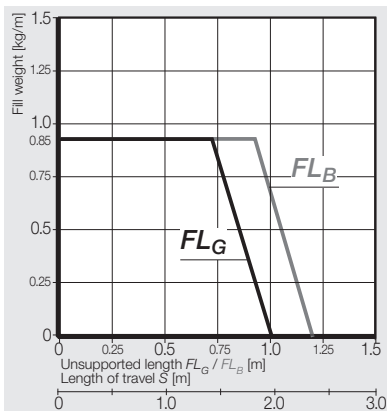

<i>R</i>	044	050	075
<i>H</i>	134	146	196
<i>D</i>	82	88	113
<i>K</i>	175	195	270

The required clearance height:  $H_F = H + 50$  mm (with 0,3 kg/m fill weight)

KMA mounting bracket | Mounting angle | polymer

Fixed end  
E3.22....2

Moving end  
E3.22...1

View mounting angle

View KMA mounting bracket

E3.150.220.12 - Space-saving allround KMA mounting brackets

Width Index	Part No. <b>New</b> in this catalog space-saving all-round KMA mounting bracket	Dim A [mm]	Dim B [mm]	Part No. full set mounting angle (single part)	Part No. strain relief for both sides	Part No. full set strain relief for both sides + 2 mounting angles
.020.	▶ E3.220.020.12	28	36	E3.22.00	E3.020.12	E3.22.020.12
.040.	▶ E3.220.040.12	48	56	E3.22.00	E3.040.12	E3.22.040.12
.060.	▶ E3.220.060.12	68	76	E3.22.00	E3.060.12	E3.22.060.12

E3.22.XXX.12 - E3 with strain relief for both sides and mounting angles

E3.00.020 - Strain relief for both sides as single parts

E3.22.00 - Mounting angle, single part

Possible installation conditions for mounting brackets.

Part No. structure

E3.22.060.12

- Full set
- Width index
- Series

Interior separation

Slotted separator for e-chains®

unassembled E3.22.01

assembled E3.22.11

Slotted separator E3.22.01

Vertical separators are used if a vertical subdivision of the e-chain® interior is required.

## 6-piece e-chains<sup>®</sup> - extremely low-noise, minimum vibration

Universal: Attachment on all sides

Low noise: Small pitch for low-noise, smooth operation

Long service life: Minimum vibration, high stability and tensile strength

Dynamic: For high speed and high accelerations

Quick assembly: Snap-open accessibility along inner or outer radius

No wear: Polymer spring - No pin and bore connection

Modular design: Can be shortened and lengthened

High stability: For unsupported applications

Variety: Available as closed e-tube for some types

The E6 Series offers numerous advantages in addition to long life cycles. It provides extremely quiet, low-vibration operation. It minimizes the polygon effect which can occur during the rolling motion of an e-chain<sup>®</sup>. The ultra-low noise levels have been confirmed in a recent report by the Rheinland Technical Inspection Agency. Our extensive delivery program offers the right chain size for any application; a wide range of interior separators are also available. The same applies to the mounting brackets.

### Typical industries and applications

● Clean room ● Printing machines ● Handling & robot ● Machine Tools ● Measuring machines ● Semiconductor industries ● Medical industries ● Electronic industries ● General machinery



System E6 - Extremely low noise - TÜV certified



LEVEL 1 absorption confirmed by IPA-Fraunhofer-Institut according to SEMI E78-0998 for the E6 standard material. Special material "igumid ESD" for ESD/ATEX applications available on request. Continuously constant conductance value as there are no pin-bore connection







A linear drive provides for highly dynamic feed of PCBs. This system is twice as fast as handling units with a toothed-belt drive; designed to withstand high dynamic loads, the E6 e-chains® ensure a supply of power, coolant and control data with ultra-low noise and vibration



E6 is one of the best solutions to guide energy, data and media for plotter, due to the smooth run and the high mechanical strength



Long travel and side mounted installation with the vibration-free and low noise Series E6.29 in this camera application

## Selected noise tests - External noise corrected measurement values

e-chain® Series	Averaging of the corrected sound pressure levels	Test method
igus® Series E6.29*	≈ 37 dB(A)	unsupported v = 1,0 m/s
igus® Series E6.52*	≈ 41 dB(A)	unsupported, side mounted v = 0,5 m/s
igus® Series E6.52	≈ 46 dB(A)	unsupported v = 2,0 m/s
Chain 1 Third-party product	≈ 77 dB(A)	unsupported v = 2,0 m/s
Chain 2 Third-party product	≈ 68 dB(A)	unsupported v = 2,0 m/s
Chain 3 Third-party product	≈ 73 dB(A)	unsupported v = 2,0 m/s

Source: TÜV Rheinland \*Source: igus® laboratory



**Noise level ≤ 46 dB(A)** A measurement conducted by the Rhineland Technical Inspection Authority (TÜV Rheinland) in May 2002 indicates a value of ≤ 46 dB(A) at 2 m/s and with an unsupported length of 1.5 m with Series E6.52.100.100.0, and all this with at least 10 dB(A) sound pressure level generated by external noise. We have received an official noise certificate from the Rhineland Technical Inspection Authority (TÜV Rheinland Berlin Brandenburg) and we are happy to provide you with a copy upon request.



## Clean room qualification of E6 e-chains®

In many applications where cumbersome special solutions are used, a simple standard e-chain® can be used instead. A comprehensive test program was devised and performed for both gliding use and unsupported use. For many applications, the e-chains® in special materials are practically abrasion-free. Detailed test results are available upon request. IPA tests confirm that standard igus® e-chains® meet clean room requirements. "Tested and certified as very good!" e-chains® for clean room applications in the test stand Clean room environments demand very high wear resistance of moving parts. e-chains®, for example, must be very wear resistant, in order to meet normal requirements for such a sensitive environment.



### IPA classification - Report IG0704-400:

- Special material "clean room" - **Class 1 according to standard DIN EN ISO 14644-1** - Note: None of the classes corresponding to the DIN EN ISO 14644-1 Class 1 is included in the US standard at  $v = 0.5 \text{ m/s}$ ,  $a = 1.0 \text{ m/s}^2$  - Series E6.29.060.150.0.CR
- Standard material - **Class 3 according to standard DIN EN ISO 14644-1** (according to US Fed. Stand. 209E, Class 1) at  $v = 0.5 \text{ m/s}$ ,  $a = 1.0 \text{ m/s}^2$  Series E6.29.060.150.0 and  $v = 1 \text{ m/s}$ ,  $a = 2 \text{ m/s}^2$  Series E6.29.050.055.0 with inserted cables CF34.15.04, CF9.05.12, CF11.02.01.02.PBA.LC.D

# E6 | Selection Table

Series	Inner height <i>hi</i> [mm]	Inner width <i>Bi</i> [mm]	Outer width <i>Ba</i> [mm]	Outer height <i>ha</i> [mm]	Bending radius <i>R</i> [mm]	Unsupported max. length [m]	Page
--------	--------------------------------	-------------------------------	-------------------------------	--------------------------------	---------------------------------	--------------------------------	------



**Crossbars every 2<sup>nd</sup> link**  
e-chains® for almost all applications - Standard

E6.29	29	30 - 140	46 - 156	35	55 - 150	≈ 1,75	500
E6.35	35	30 - 140	50 - 160	42	55 - 100	≈ 1,90	504
E6.40	40	40 - 300	60 - 320	54	63 - 200	≈ 2,75	508
E6.52	52	40 - 300	64 - 324	65	75 - 250	≈ 3,00	514
E6.62	62	50 - 400	86 - 436	84	115 - 350	≈ 4,00	520
E6.80L	80	87 - 550	115 - 578	108	175	≈ 2,50	524
E6.80	80	50 - 600	100 - 650	108	150 - 450	≈ 5,25	528



**e-tubes**  
fully enclosed,  
excellent cable protection

R6.29	28	30 - 120	46 - 136	35	55 - 150	≈ 1,75	500
R6.40	40	62	82	54	63 - 200	≈ 2,75	508
R6.52	52	50 - 175	74 - 199	65	75 - 250	≈ 3,00	514

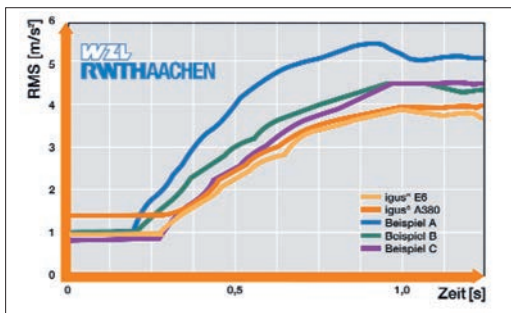
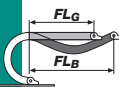

Chart: Study of the Laboratory of Machine Tools and Production Engineering (WZL) of the RWTH Aachen on "Vibration tests in energy supply chains". Result: The "E6" energy supply system of the company igus® GmbH, Cologne, is characterized by extreme low vibration and smooth running

## Technical Data



Gliding speed / acceleration (maximum) upon request<sup>1)</sup>



Speed / acceleration  $FL_G$  max. max. 20 [m/s] / max. 200 [m/s<sup>2</sup>]

Speed / acceleration  $FL_B$  max. max. 3 [m/s] / max. 6 [m/s<sup>2</sup>]



Permitted temperature °C -40° up to +70° C







Flammability class VDE 0304 IIC UL94-HB

■  $FL_G$  = with straight upper run ■  $FL_B$  = with permitted sag

1) In special cases, gliding applications are also possible, please consult igus®.

## Installation methods overview, maximum travels

e-chain® / e-tube Series	 Unsupported application	 Gliding application	 Vertical hanging	 Vertical standing	 Side mounted unsupported
E6.29 / R6.29	≤ 1,75 m	upon request <sup>1)</sup>	≤ 30 m	≤ 2,0 m	upon request
E6.35	≤ 1,90 m	upon request <sup>1)</sup>	≤ 30 m	≤ 2,0 m	upon request
E6.40 / R6.40	≤ 2,75 m	upon request <sup>1)</sup>	≤ 30 m	≤ 2,0 m	upon request
E6.52 / R6.52	≤ 3,00 m	upon request <sup>1)</sup>	≤ 50 m	≤ 2,0 m	upon request
E6.62	≤ 4,00m	upon request <sup>1)</sup>	≤ 60 m	≤ 3,0 m	upon request
E6.80L	≤ 2,50 m	upon request <sup>1)</sup>	≤ 60 m	≤ 4,0 m	upon request
E6.80	≤ 5,25 m	upon request <sup>1)</sup>	≤ 60 m	≤ 4,0 m	upon request

1) In special cases, gliding applications are also possible, please consult igus®.

# E6 | Order keys and Options

## Options with order keys based on Series E6.52



Standard

Part No.  
Standard  
e-chains®/e-tubes



E6.52.100.R.0



Delivery  
from stock

NC-Version -  
(no camber)  
without pretension

Part No.  
NC-Version  
e-chains®/e-tubes



E6.52.100.R.0.NC

Delivery time:  
upon request

## Order example | Order key and color options based on Series E6.52



Order example for complete e-chain® (1,0 m),  
color black, with mounting brackets and interior separation:

e-chain® (1,0 m)	Please indicate e-chain® length or number of links: 1,0 m or 34 links	E6.52.100.075.0
+ Mounting brackets	KMA, pivoting - 1set	E6.520.100.12
+ Interior separation	with 2 separators assembled every 2 <sup>nd</sup> link	2 x 38222

Order text: 1,0 m E6.52.100.075.0 + E6.520.100.12 + 2 x 38222



### Order key

e-chain® crossbars every link: **E6.52.100.075.0**  
e-tube fully enclosed: **R6.52.100.075.0**

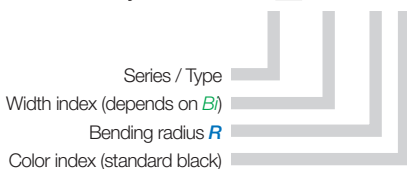

### General igus® color options for e-chains® and e-tubes

Color	Order index	Color	Order index
Black Standard, from stock!	.0	White special color	.1
Slate grey only ESD material	.ESD	Gray white special color	.1S
Gray brown only HT material	.HT	Orange special color	.2
Gray special color only e-chains®	.3	Yellow special color	.4
Dusty grey special color only e-tubes	.31	Light grey special color	.14

Black e-chains® available from stock!

Delivery time for special colors: upon request

E6.52.100.075.0 = with crossbars every 2<sup>nd</sup> link, inner width *B* 100 mm, radius *R* 75 mm, color black



Standard ...E6.29

crossbars every 2<sup>nd</sup> link

...R6.29

fully enclosed

**e-chains® | Series E6.29 crossbars every 2<sup>nd</sup> link** (crossbars removable along both radii)

**e-tubes | Series R6.29 fully enclosed** (lids can be removed along inner and outer radius)

Part No. e-chains® / e-tubes	<i>Bi</i> [mm]	<i>Ba</i> [mm]	E6.29 [kg/m]	R6.29 [kg/m]	Part No. e-chains® / e-tubes	<i>Bi</i> [mm]	<i>Ba</i> [mm]	E6.29 [kg/m]	R6.29 [kg/m]
E6.29. R6.29. <b>030. R.0</b>	<b>30</b>	<b>46</b>	0,73	0,80	E6.29. R6.29.* <b>090. R.0</b>	<b>90</b>	<b>106</b>	0,88	1,08
E6.29. R6.29. <b>040. R.0</b>	<b>40</b>	<b>56</b>	0,75	0,85	E6.29. R6.29.* <b>100. R.0</b>	<b>100</b>	<b>116</b>	0,90	1,13
E6.29. R6.29. <b>050. R.0</b>	<b>50</b>	<b>66</b>	0,78	0,89	E6.29. R6.29. <b>110. R.0</b>	<b>110</b>	<b>126</b>	0,93	1,18
E6.29. R6.29. <b>060. R.0</b>	<b>60</b>	<b>76</b>	0,80	0,94	E6.29. R6.29. <b>120. R.0</b>	<b>120</b>	<b>136</b>	0,95	1,22
E6.29. R6.29. <b>070. R.0</b>	<b>70</b>	<b>86</b>	0,83	0,97	E6.29. - <b>140. R.0</b>	<b>140</b>	<b>156</b>	1,00	-
E6.29. R6.29. <b>080. R.0</b>	<b>80</b>	<b>96</b>	0,85	1,03					

\*Width available upon request, please consult igus® for delivery time!

Available bending radii *R* [mm] **055 | 075 | 100 | 150**

Supplement Part No. with required radius (*R*). Examples:

**E6.29.080.100.0** = e-chain® with crossbars every 2<sup>nd</sup> link, inner width *Bi* 80 mm, radius *R* 100 mm, color black

**R6.29.080.100.0** = e-tube fully enclosed, inner width *Bi* 80 mm, radius *R* 100 mm, color black

## Dimensions

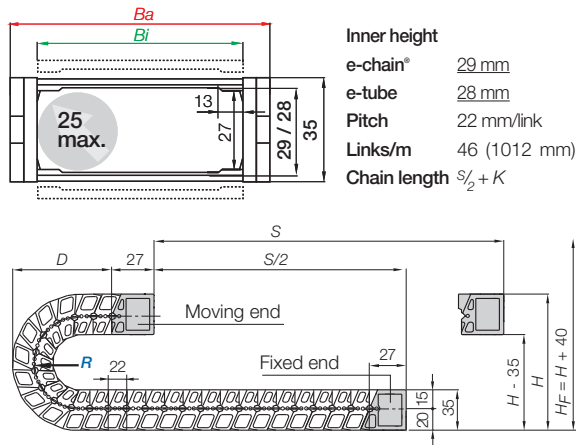
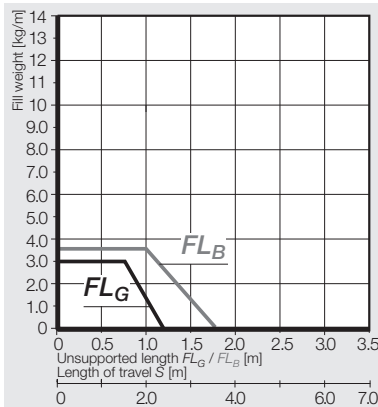

<i>R</i>	<b>055</b>	<b>075</b>	<b>100</b>	<b>150</b>
<i>H</i>	180	220	270	370
<i>D</i>	108	128	153	203
<i>K</i>	220	280	360	520

The required clearance height:  $H_F = H + 40$  mm (with 2,0 kg/m fill weight)

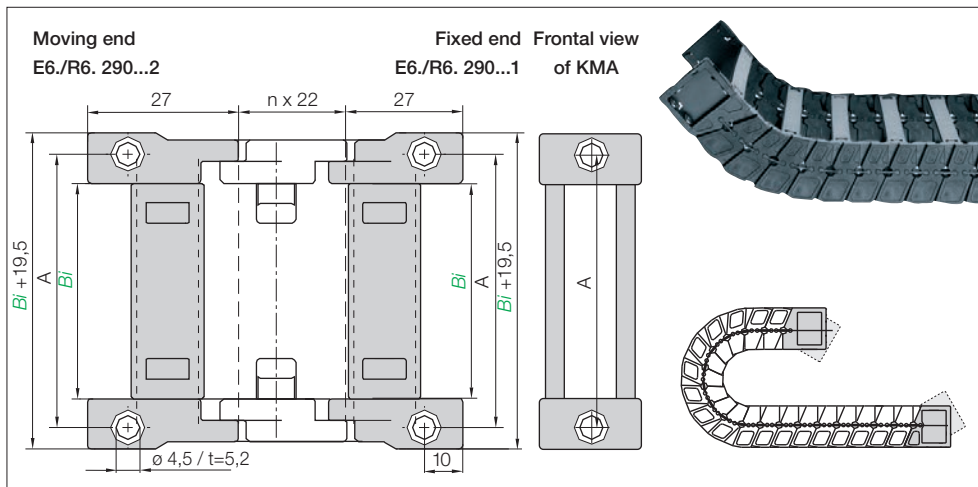

### KMA pivoting | Standard | Recommended for unsupported applications

Width Index	Part No. full set KMA pivoting:	Dim A [mm]	Bi [mm]	Width Index	Part No. full set KMA pivoting:	Dim A [mm]	Bi [mm]
030.	▶ E6.290. R6.290. 030. 12	40	30	090.	▶ E6.290. R6.290.* 090. 12	100	90
040.	▶ E6.290. R6.290. 040. 12	50	40	100.	▶ E6.290. R6.290.* 100. 12	110	100
050.	▶ E6.290. R6.290. 050. 12	60	50	110.	▶ E6.290. R6.290. 110. 12	120	110
060.	▶ E6.290. R6.290. 060. 12	70	60	120.	▶ E6.290. R6.290. 120. 12	130	120
070.	▶ E6.290. R6.290. 070. 12	80	70	140.	▶ E6.290. - 140. 12	150	140
080.	▶ E6.290. R6.290. 080. 12	90	80				

(KMA = Polymer Metal Mounting Bracket)

\*Available upon request, please consult igus\* for delivery time!

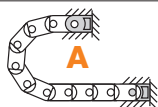



These attachment types are set automatically in the choice of the KMA mounting bracket. For the **preassembled** mode please add index **A**.

**E6.290.080.12A** Part No. structure

- A... must be indicated on preassembled configurations
- Full set
- Width index
- Series

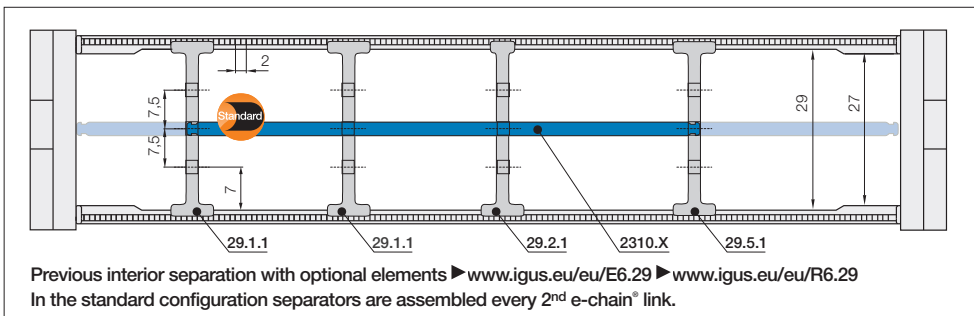
 **Strain relief** e.g. clamps, tiwrap plates, nuggets and plug-in clips are available from stock. The complete chainfix range with order options ▶ from page 630

**Standard separator, wide base**

unassembled **29.1**  
assembled **29.1.1**

**Standard - for all applications**  
Separator with a wide base for maximum locking strength and safe standing in e-chains®.



**Separator, narrow head**

unassembled **29.2**  
assembled **29.2.1**

**For even faster installation**  
Firm hold to one side with a wide base, narrow on opposed side for easy cable assembly (slight grip).



**Notch separator for notch crossbar\***

unassembled **29.5**  
assembled **29.5.1**

**Locks safely in 2 mm increments**  
Notch separator for exact positioning in e-chains®. Recommended for side-mounted applications.



**Full-width shelf, lockable**

unassembled **2300.X**  
assembled **2310.X**

**Horizontal separation**  
Shelf locks safely into separators on both ends, fixed width possible. Separators can be moved freely over the shelf in horizontal direction. Can be arranged at 3 different heights.



**Lockable full-width shelves - for the standard interior separation**

Width X [mm]	unassembled	assembled	Width X [mm]	unassembled	assembled	Width X [mm]	unassembled	assembled
015	2300.015	2310.015	060	2300.060	2310.060	087	2300.087	2310.087
025	2300.025	2310.025	062	2300.062	2310.062	090	2300.090	2310.090
030	2300.030	2310.030	065	2300.065	2310.065	100	2300.100	2310.100
038	2300.038	2310.038	070	2300.070	2310.070	103	2300.103	2310.103
040	2300.040	2310.040	075	2300.075	2310.075	110	2300.110	2310.110
050	2300.050	2310.050	077	2300.077	2310.077	120	2300.120	2310.120
057	2300.057	2310.057	080	2300.080	2310.080	125	2300.125	2310.125



## Interior separation | Only for e-tubes

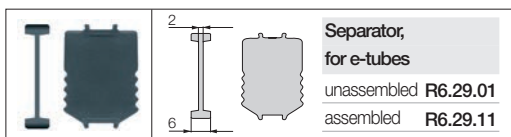
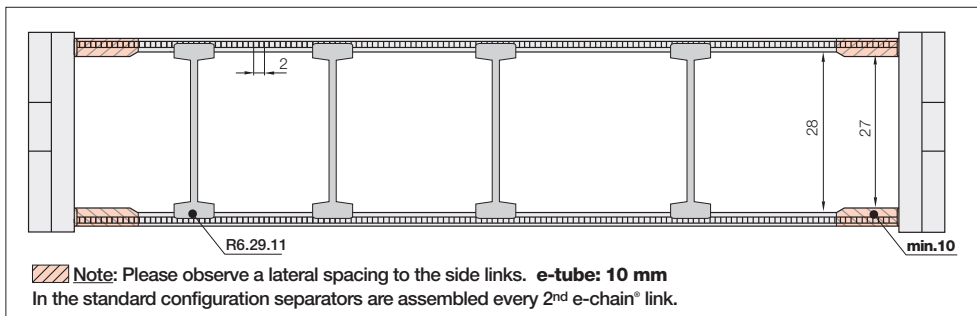

### Separator R6.29.01 (e-tubes only)

For e-tubes R6.29. The notches on this separator mark the side that fixes to the lid.

### Separator with integrated strain relief

Strain relief separator Part No. **E6.29.02.Z** (for e-chains®) and **R6.29.02.Z** (for e-tubes) can be integrated into the mounting bracket and can be placed there at any point of the e-chain®. It combines strain relief and interior separation ● For the use in the first or last chain link ● Easy to assemble without any screws.  
**Further Information ► from page 650**



### Optional: Support tray tool kit.

#### For support of the lower run.

Simple one-piece support trays according to your requirements and specification.  
**The complete range with order options ► from page 714**



Extremely low-noise, minimum vibration, medium size

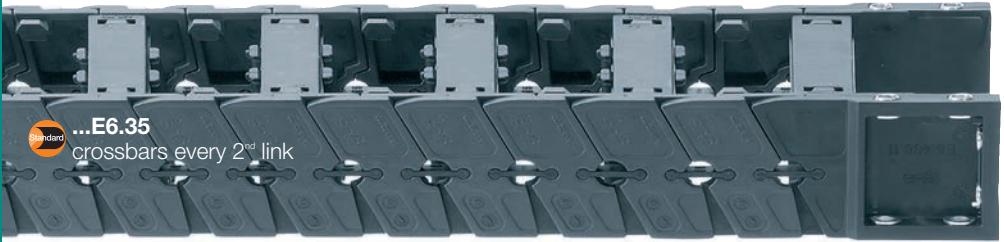

...E6.35  
crossbars every 2<sup>nd</sup> link

e-chains® | Series E6.35 crossbars every 2<sup>nd</sup> link (crossbars removable along both radii)

Part No. e-chains®	Bi [mm]	Ba [mm]	E6.35 [kg/m]	Part No. e-chains®	Bi [mm]	Ba [mm]	E6.35 [kg/m]
E6.35.030.R.0	30	50	0,88	E6.35.090.R.0	90	110	1,01
E6.35.040.R.0	40	60	0,90	E6.35.100.R.0	100	120	1,03
E6.35.050.R.0	50	70	0,92	E6.35.110.R.0	110	130	1,05
E6.35.060.R.0	60	80	0,94	E6.35.120.R.0	120	140	1,07
E6.35.070.R.0	70	90	0,96	E6.35.140.R.0	140	160	1,11
E6.35.080.R.0	80	100	0,99				

\*Radius available upon request, please consult igus® for delivery time

Available bending radii  $R$  [mm] 055 | 075 | 100 | 125\* | 150 |

Supplement Part No. with required radius ( $R$ ). Example:

E6.35.100.100.0 = e-chain® with crossbars every 2<sup>nd</sup> link, inner width  $Bi$  100 mm, radius  $R$  100 mm, color black

## Dimensions

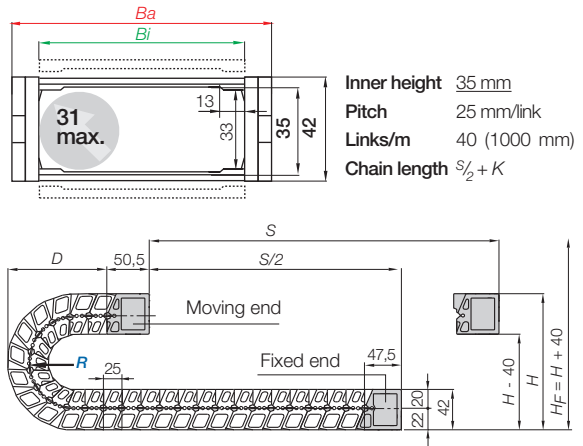
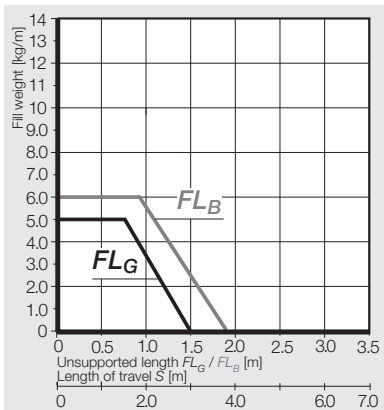

R	055	075	100	125*	150
H	189	229	279	329	379
D	115	135	160	185	210
K	225	290	365	445	525

The required clearance height:  $H_f = H + 40$  mm (with 2,0 kg/m fill weight)

\*Radius available upon request, please consult igus® for delivery time

504 3D-CAD files, configurators, PDF ► [www.igus.eu/eu/E6.35](http://www.igus.eu/eu/E6.35)

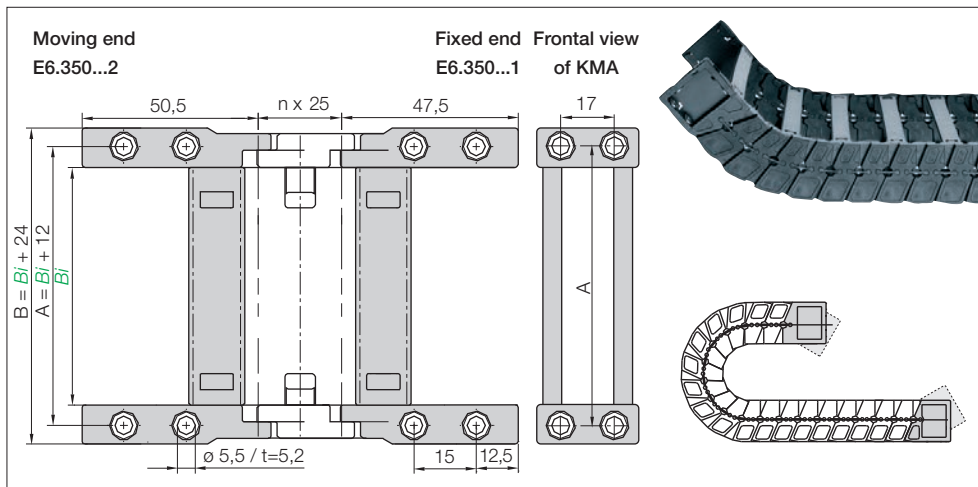

### KMA pivoting | Standard | Recommended for unsupported applications

Width Index	Part No. full set <b>KMA pivoting:</b>	Dim A [mm]	Dim B [mm]	Bi [mm]	Width Index	Part No. full set <b>KMA pivoting:</b>	Dim A [mm]	Dim B [mm]	Bi [mm]
030. ▶	<b>E6.350.030.12</b>	42	54	<b>30</b>	090. ▶	<b>E6.350.090.12</b>	102	114	<b>90</b>
040. ▶	<b>E6.350.040.12</b>	52	64	<b>40</b>	100. ▶	<b>E6.350.100.12</b>	112	124	<b>100</b>
050. ▶	<b>E6.350.050.12</b>	62	74	<b>50</b>	110. ▶	<b>E6.350.110.12</b>	122	134	<b>110</b>
060. ▶	<b>E6.350.060.12</b>	72	84	<b>60</b>	120. ▶	<b>E6.350.120.12</b>	132	144	<b>120</b>
070. ▶	<b>E6.350.070.12</b>	82	94	<b>70</b>	140. ▶	<b>E6.350.140.12</b>	152	164	<b>140</b>
080. ▶	<b>E6.350.080.12</b>	92	104	<b>80</b>					

(KMA = Polymer Metal Mounting Bracket)

**A**

These attachment types are set automatically in the choice of the KMA mounting bracket. For the **preassembled** mode please add index **A**.

**E6.350.100.12A** Part No. structure

- A... must be indicated on preassembled configurations
- Full set
- Width index
- Series

**Strain relief** e.g. clamps, tiwrap plates, nuggets and plug-in clips are available from stock. The complete chainfix range with order options ▶ from page 630

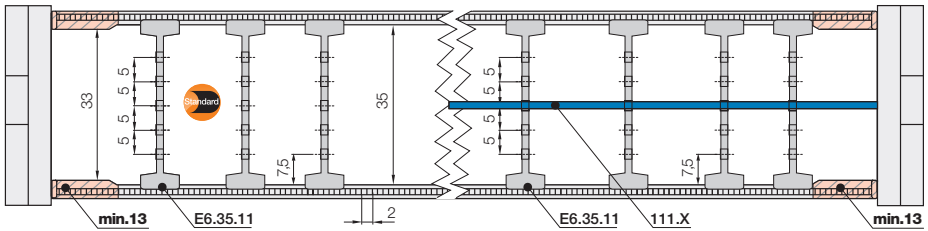

**Note:** Please observe a lateral spacing to the side links. **e-chain®: 13 mm**  
In the standard configuration separators are assembled every 2<sup>nd</sup> e-chain® link.

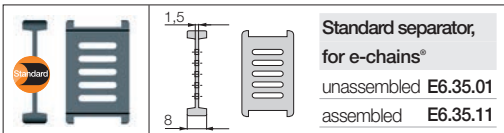

**Standard separator,  
for e-chains®**  
unassembled **E6.35.01**  
assembled **E6.35.11**

### Vertical Separator E6.35.01

They are used if a vertical subdivision of the e-chain® interior is required.  
For combinations with full-width shelf 110.X.

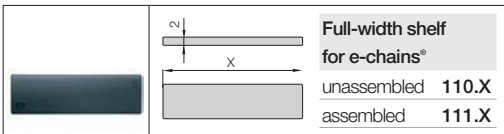

**Full-width shelf  
for e-chains®**  
unassembled **110.X**  
assembled **111.X**

### Full-width shelf 110.X

For cables with similar or identical diameters and a consequent subdivision. Full-width shelves can be arranged at 5 different heights (in 5 mm increments).

### Full-width shelves 110.X

Width X [mm]	unassembled	assembled	Width X [mm]	unassembled	assembled	Width X [mm]	unassembled	assembled
030	110.30	111.30	070	110.70	111.70	110	110.110	111.110
040	110.40	111.40	080	110.80	111.80	120	110.120	111.120
050	110.50	111.50	090	110.90	111.90			
060	110.60	111.60	100	110.100	111.100			

### Separator with integrated strain relief

Strain relief separator Part No. **E6.35.02.Z** can be integrated into the mounting bracket and can be placed there at any point of the e-chain®. It combines strain relief and interior separation ● For the use in the first or last chain link ● Easy to assemble without any screws. **Further Information ► from page 636**



## Interior separation | Option 3

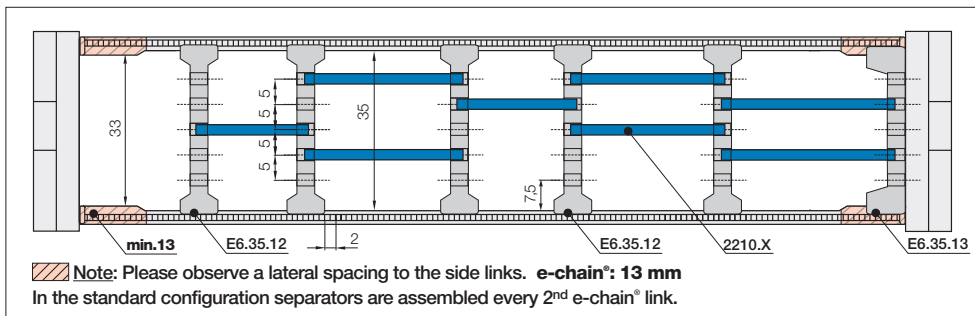

**Middle plate E6.35.12**  
for e-chains®  
unassembled **E6.35.02**  
assembled **E6.35.12**

### Middle plate E6.35.12

Shelves can be arranged at 5 different heights. Middle plate E6.35.12 for combinations with side plate E6.35.13, and shelf 2200.X

**Side plate E6.35.03**  
for e-chains®  
unassembled **E6.35.03**  
assembled **E6.35.13**

### Side plate E6.35.03

for combinations with middle plate E6.35.02, and shelf 2200.X. No minimum space is required!

**Shelf 2200.X**  
for e-chains®  
unassembled **2200.X**  
assembled **2210.X**

### Shelf 2200.X

For applications involving many cables with different diameters, shelves can be arranged at alternate heights. They can be arranged at 5 different heights (in 5 mm increments).

### Shelves 2200.X

Width X [mm]	unassembled	assembled	Width X [mm]	unassembled	assembled	Width X [mm]	unassembled	assembled
018	2200.18	2210.18	043	2200.43	2210.43	073	2200.73	2210.73
023	2200.23	2210.23	048	2200.48	2210.48	076	2200.76	2210.76
028	2200.28	2210.28	058	2200.58	2210.58	088	2200.88	2210.88
033	2200.33	2210.33	063	2200.65	2210.65	099	2200.99	2210.99
038	2200.38	2210.38	068	2200.68	2210.68			

### Optional: Support tray tool kit.

#### For support of the lower run.

Simple one-piece support trays according to your requirements and specification.

The complete range with order options ► from page 700

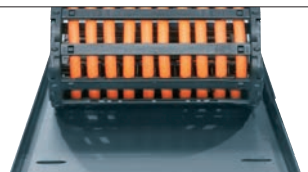

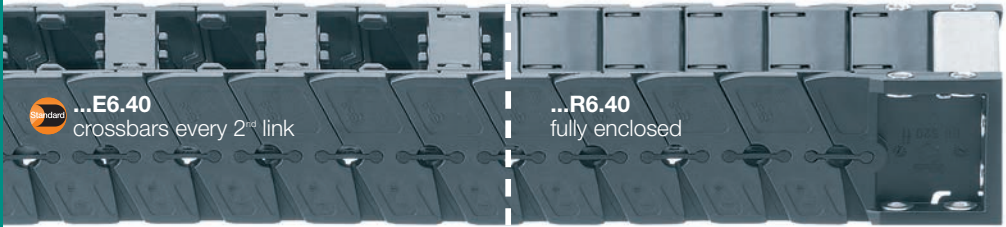

e-chains® | Series E6.40 crossbars every 2<sup>nd</sup> link (crossbars removable along both radii)  
e-tubes | Series R6.40 fully enclosed (lids can be removed along inner and outer radius)

Part No. e-chains® / e-tubes	<i>Bi</i> [mm]	<i>Ba</i> [mm]	E6.40 [kg/m]	R6.40 [kg/m]
E6.40. R6.40.* 040. R.0	40	60	1,29	-
E6.40. R6.40.* 050. R.0	50	70	1,33	-
E6.40. R6.40.* 062. R.0	62	82	1,38	1,59
E6.40. R6.40.* 070. R.0	70	90	1,41	-
E6.40. R6.40.* 075. R.0	75	95	1,43	1,65
E6.40. R6.40.* 087. R.0	87	107	1,48	-
E6.40. R6.40.* 100. R.0	100	120	1,53	-
E6.40. R6.40.* 125. R.0	125	145	1,63	-

Part No. e-chains® / e-tubes	<i>Bi</i> [mm]	<i>Ba</i> [mm]	E6.40 [kg/m]	R6.40 [kg/m]
E6.40. R6.40.* 150. R.0	150	170	1,73	-
E6.40. R6.40.* 175. R.0	175	195	1,83	-
E6.40. R6.40.* 200. R.0	200	220	1,93	-
E6.40. R6.40.* 225. R.0	225	245	2,02	-
E6.40. R6.40.* 250. R.0	250	270	2,12	-
E6.40. R6.40.* 275. R.0	275	295	2,22	-
E6.40. R6.40.* 300. R.0	300	320	2,32	-

\*Width available upon request, please consult igus® for delivery time!

Available bending radii *R* [mm] 063 | 075 | 100 | 125 | 150 | 200

Supplement Part No. with required radius (*R*). Examples:

E6.40.100.100.0 = e-chain® with crossbars every 2<sup>nd</sup> link, inner width *Bi* 100 mm, radius *R* 100 mm, color black

R6.40.100.100.0 = e-tube fully enclosed, inner width *Bi* 100 mm, radius *R* 100 mm, color black



## Unsupported applications | Short travels

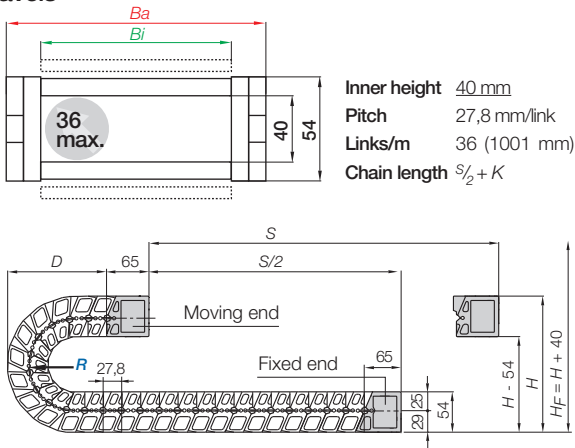
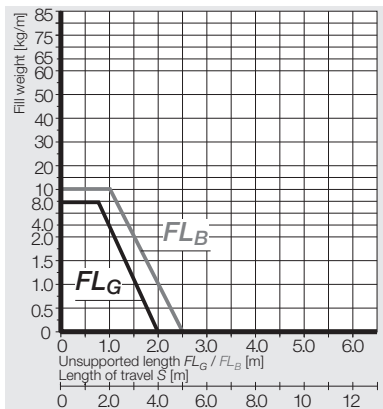

Inner height 40 mm  
Pitch 27,8 mm/link  
Links/m 36 (1001 mm)  
Chain length  $S/2 + K$

<b>R</b>	<b>063</b>	<b>075</b>	<b>100</b>	<b>125</b>	<b>150</b>	<b>200</b>
<b>H</b>	224	248	298	348	398	498
<b>D</b>	134	146	171	196	221	271
<b>K</b>	255	295	370	450	530	685

The required clearance height:  $H_F = H + 40$  mm (with 2,0 kg/m fill weight)



If you need this series for gliding applications, please consult igus®!

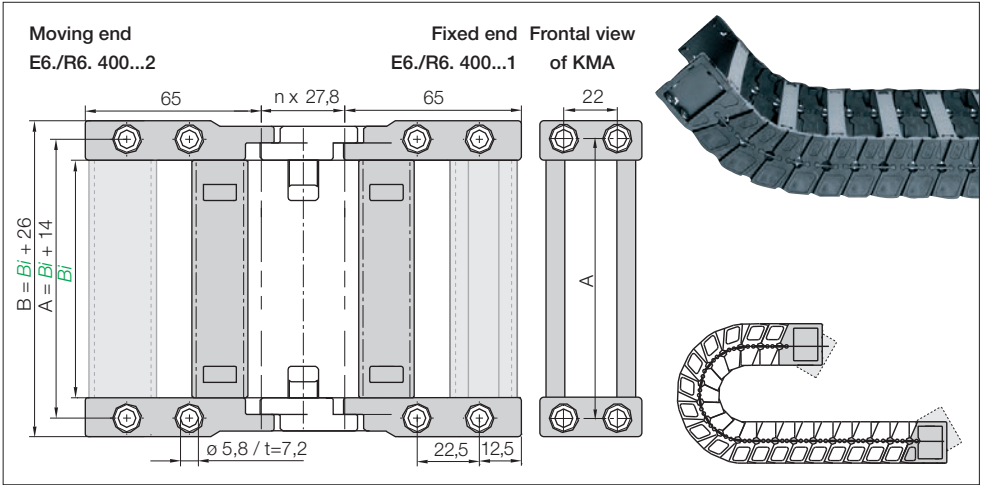

KMA pivoting | Standard | Recommended for unsupported applications

Width Index	Part No. full set KMA pivoting: (optional with C-profile)	Dim A [mm]	Dim B [mm]	Bi [mm]	Width Index	Part No. full set KMA pivoting: (optional with C-profile)	Dim A [mm]	Dim B [mm]	Bi [mm]
040.	▶ E6.400. R6.400.* 040.12.C	54	66	40	150.	▶ E6.400. R6.400.* 150.12.C	154	176	150
050.	▶ E6.400. R6.400.* 050.12.C	64	76	50	175.	▶ E6.400. R6.400.* 175.12.C	189	201	175
062.	▶ E6.400. R6.400.* 062.12.C	76	88	62	200.	▶ E6.400. R6.400.* 200.12.C	214	226	200
070.	▶ E6.400. R6.400.* 070.12.C	84	96	70	225.	▶ E6.400. R6.400.* 225.12.C	239	251	225
075.	▶ E6.400. R6.400.* 075.12.C	89	101	75	250.	▶ E6.400. R6.400.* 250.12.C	264	276	250
087.	▶ E6.400. R6.400.* 087.12.C	101	113	87	275.	▶ E6.400. R6.400.* 275.12.C	289	301	275
100.	▶ E6.400. R6.400.* 100.12.C	114	126	100	300.	▶ E6.400. R6.400.* 300.12.C	314	326	300
125.	▶ E6.400. R6.400.* 125.12.C	139	151	125					

\*Width available upon request, please consult igus\* for delivery time!

(KMA = Polymer Metal Mounting Bracket)

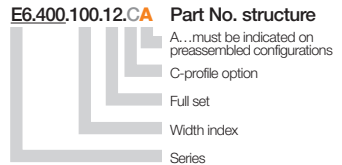
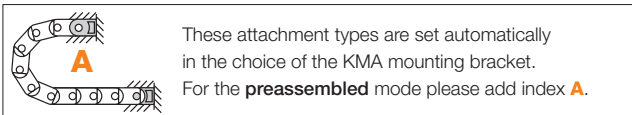

**Strain relief** e.g. clamps, tiewrap plates, nuggets and plug-in clips are available from stock. The complete chainfix range with order options ▶ from page 630



Interior separation | New generation | Only for e-chains® (e-tubes ▶ next page)

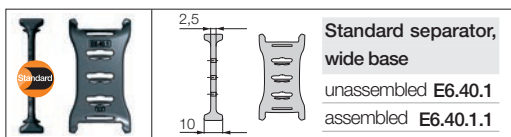
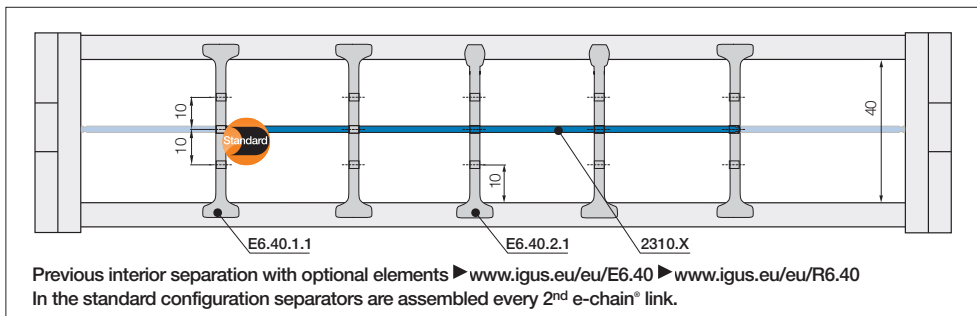

**Standard - for all applications**

Separator with a wide base for maximum locking strength and safe standing in e-chains®.

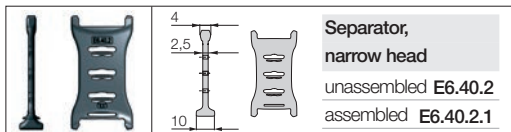

**For even faster installation**

Firm hold to one side with a wide base, narrow on opposed side for easy cable assembly (slight grip).

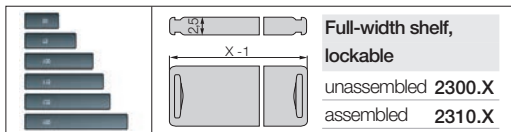

**Horizontal separation**

Shelf locks safely into separators on both ends, fixed width though possible. Separators can be moved freely over the shelf in horizontal direction. Can be arranged at 3 different heights.



**Lockable full-width shelves - for the standard interior separation**

Width X [mm]	unassembled	assembled	Width X [mm]	unassembled	assembled	Width X [mm]	unassembled	assembled
015	2300.015	2310.015	060	2300.060	2310.060	087	2300.087	2310.087
025	2300.025	2310.025	062	2300.062	2310.062	090	2300.090	2310.090
030	2300.030	2310.030	065	2300.065	2310.065	100	2300.100	2310.100
038	2300.038	2310.038	070	2300.070	2310.070	103	2300.103	2310.103
040	2300.040	2310.040	075	2300.075	2310.075	110	2300.110	2310.110
050	2300.050	2310.050	077	2300.077	2310.077	120	2300.120	2310.120
057	2300.057	2310.057	080	2300.080	2310.080	125	2300.125	2310.125

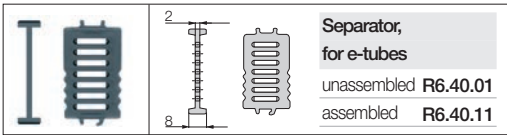
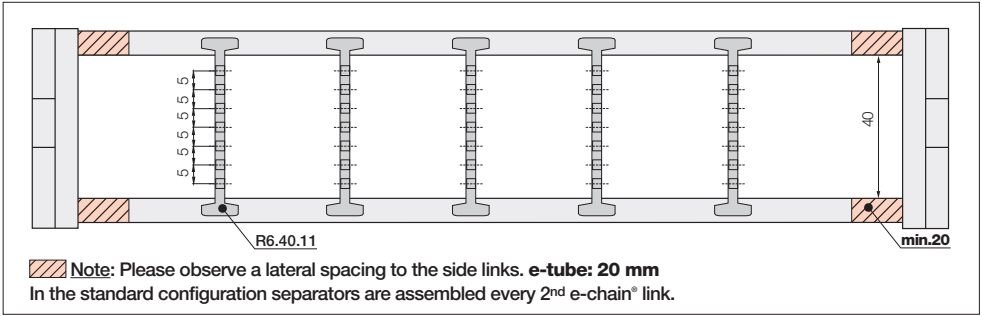

### Separator R6.52.01 (e-tubes only)

For e-tubes R6.52. The notches on this separator mark the side that fixes to the lid.

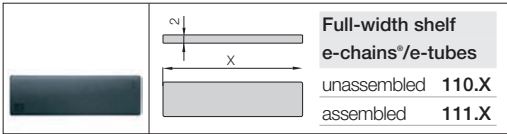

### Full-width shelf 110.X

this option makes sense in applications with many thin cables with similar diameters. For a consequent sub-division. Full-width shelves can be arranged at 7 different heights (in 5 mm increments).

### Full-width shelves

Width X [mm]	unassembled	assembled
050	110.50	111.50

## Separator with integrated strain relief

Strain relief separator Part No. E6.40.02.Z can be integrated into the mounting bracket and can be placed there at any point of the e-chain®. It combines strain relief and interior separation ● For the use in the first or last chain link ● Easy to assemble without any screws. **Further Information ▶ from page 650**



## Optional: Support tray tool kit.

### For support of the lower run.

Simple one-piece support trays according to your requirements and specification. **The complete range with order options ▶ from page 714**

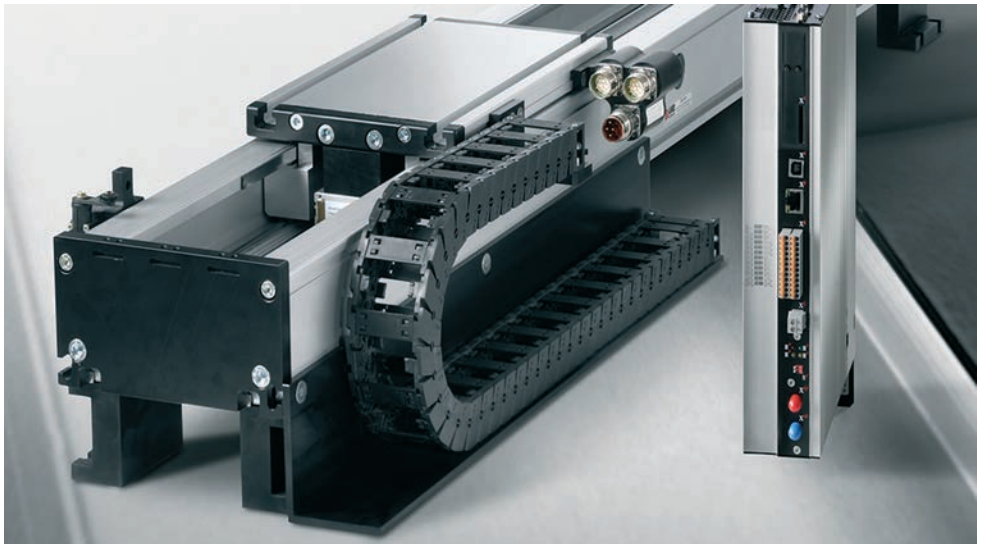

igus®System E6 on a linear drive for high speeds

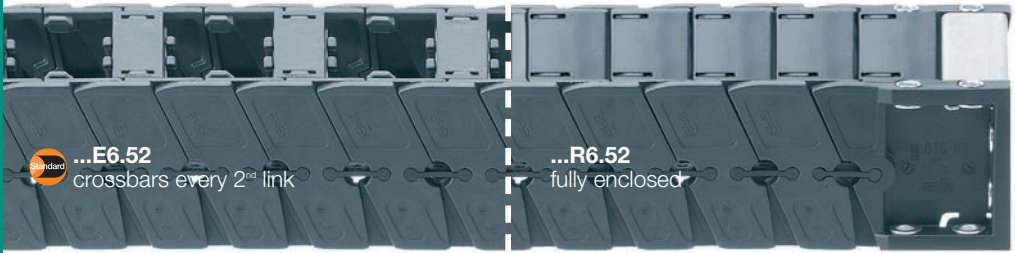

e-chains® | Series E6.52 crossbars every 2<sup>nd</sup> link (crossbars removable along both radii)  
e-tubes | Series R6.52 fully enclosed (lids can be removed along inner and outer radius)

Part No. e-chains® / e-tubes	<i>Bi</i> [mm]	<i>Ba</i> [mm]	E6.52 [kg/m]	R6.52 [kg/m]
E6.52. R6.52.* 040. R.0	40	64	≈ 1,76	≈ 1,78
E6.52. R6.52. 050. R.0	50	74	≈ 1,80	≈ 1,89
E6.52. R6.52.* 062. R.0	62	86	≈ 1,84	≈ 1,97
E6.52. R6.52.* 070. R.0	70	94	≈ 1,87	≈ 2,07
E6.52. R6.52. 075. R.0	75	99	≈ 1,89	≈ 2,12
E6.52. R6.52.* 087. R.0	87	111	≈ 1,94	≈ 2,21
E6.52. R6.52. 100. R.0	100	124	≈ 1,98	≈ 2,35
E6.52. R6.52. 125. R.0	125	149	≈ 2,07	≈ 2,57

Part No. e-chains® / e-tubes	<i>Bi</i> [mm]	<i>Ba</i> [mm]	E6.52 [kg/m]	R6.52 [kg/m]
E6.52. R6.52. 150. R.0	150	174	≈ 2,17	≈ 2,80
E6.52. R6.52. 175. R.0	175	199	≈ 2,26	≈ 3,03
E6.52. R6.52.* 200. R.0	200	224	≈ 2,36	≈ 3,25
E6.52. R6.52.* 225. R.0	225	249	≈ 2,45	≈ 3,46
E6.52. R6.52.* 250. R.0	250	274	≈ 2,54	≈ 3,68
E6.52. R6.52.* 275. R.0	275	299	≈ 2,64	≈ 3,92
E6.52. R6.52.* 300. R.0	300	324	≈ 2,73	≈ 4,15

\*Width available upon request, please consult igus® for delivery time!

Available bending radii *R* [mm] 075 | 100 | 150 | 200 | 250 |

Supplement Part No. with required radius (*R*). Examples:

E6.52.100.100.0 = e-chain® with crossbars every 2<sup>nd</sup> link, inner width *Bi* 100 mm, radius *R* 100 mm, color black

R6.52.100.100.0 = e-tube fully enclosed, inner width *Bi* 100 mm, radius *R* 100 mm, color black



## Unsupported applications | Short travels

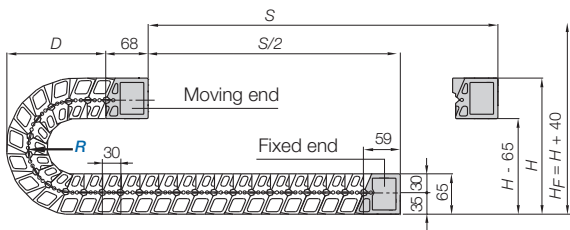
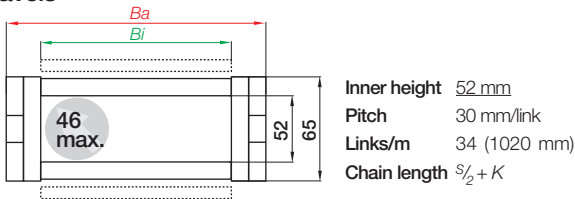
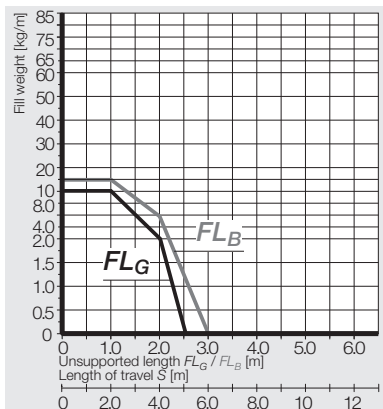

<b>R</b>	<b>075</b>	<b>100</b>	<b>150</b>	<b>200</b>	<b>250</b>
<b>H</b>	270	320	420	520	620
<b>D</b>	155	180	230	280	330
<b>K</b>	300	375	535	690	850

The required clearance height:  $H_F = H + 40$  mm (with 2,0 kg/m fill weight)



If you need this series for gliding applications, please consult igus®!

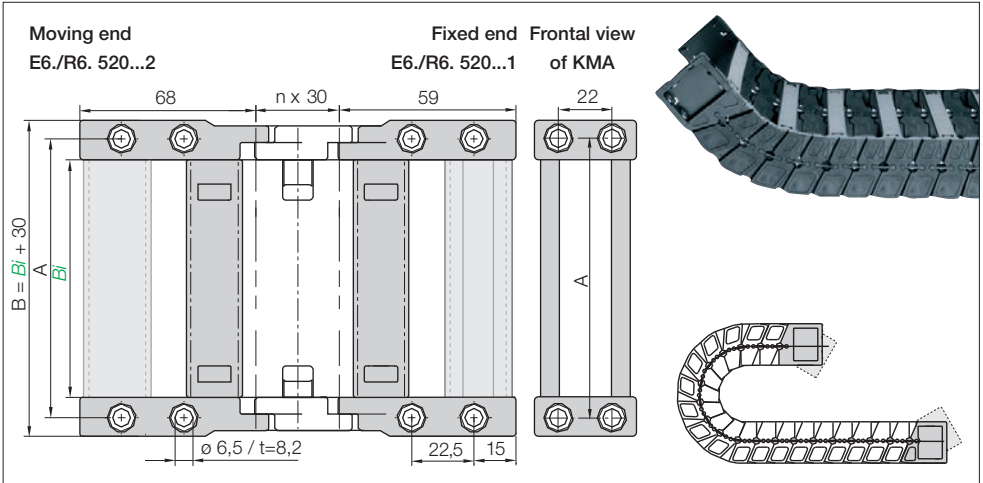

KMA pivoting | Standard | Recommended for unsupported applications

Width Index	Part No. full set KMA pivoting: (optional with C-profile)	Dim A [mm]	Dim B [mm]	Bi [mm]	Width Index	Part No. full set KMA pivoting: (optional with C-profile)	Dim A [mm]	Dim B [mm]	Bi [mm]
040.	▶ E6.520. R6.520.* 040.12.C	56	70	40	150.	▶ E6.520. R6.520. 150.12.C	166	180	150
050.	▶ E6.520. R6.520. 050.12.C	66	80	50	175.	▶ E6.520. R6.520. 175.12.C	191	205	175
062.	▶ E6.520. R6.520.* 062.12.C	78	92	62	200.	▶ E6.520. R6.520.* 200.12.C	216	230	200
070.	▶ E6.520. R6.520.* 070.12.C	86	100	70	225.	▶ E6.520. R6.520.* 225.12.C	241	255	225
075.	▶ E6.520. R6.520. 075.12.C	91	105	75	250.	▶ E6.520. R6.520.* 250.12.C	266	280	250
087.	▶ E6.520. R6.520.* 087.12.C	103	117	87	275.	▶ E6.520. R6.520.* 275.12.C	291	300	275
100.	▶ E6.520. R6.520. 100.12.C	116	130	100	300.	▶ E6.520. R6.520.* 300.12.C	316	330	300
125.	▶ E6.520. R6.520. 125.12.C	141	155	125					

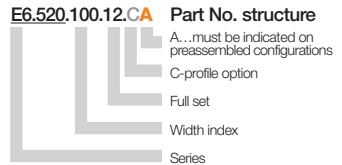
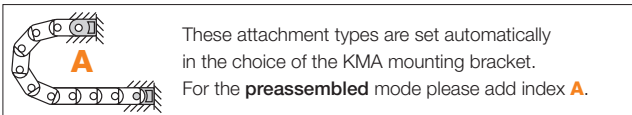

\*Width available upon request, please consult igus\* for delivery time!

(KMA = Polymer Metal Mounting Bracket)

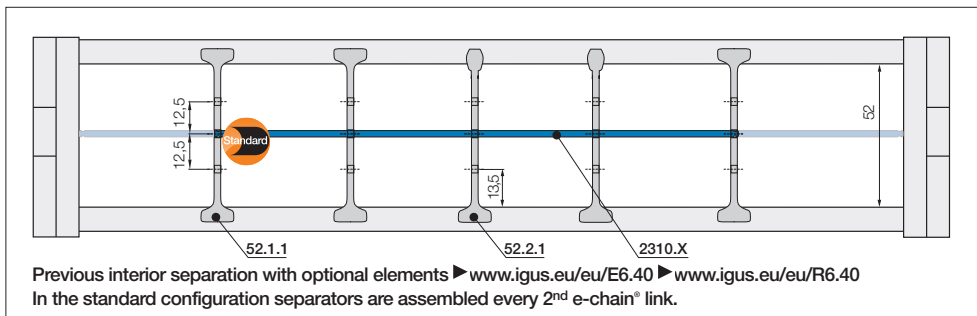

**Strain relief** e.g. clamps, tiewrap plates, nuggets and plug-in clips are available from stock. The complete chainfix range with order options ▶ from page 630

Interior separation | New generation | Only for e-chains® (e-tubes ▶ next page)





**Standard separator, wide base**

unassembled	<b>52.1</b>
assembled	<b>52.1.1</b>

**Standard - for all applications**

Separator with a wide base for maximum locking strength and safe standing in e-chains®.



**Separator, narrow head**

unassembled	<b>52.2</b>
assembled	<b>52.2.1</b>

**For even faster installation**

Firm hold to one side with a wide base, narrow on opposed side for easy cable assembly (slight grip).



**Full-width shelf, lockable**

unassembled	<b>2300.X</b>
assembled	<b>2310.X</b>

**Horizontal separation**

Shelf locks safely into separators on both ends, fixed width possible. Separators can be moved freely over the shelf in horizontal direction. Can be arranged at 3 different heights.



**Lockable full-width shelves - for the standard interior separation**

Width X [mm]	unassembled	assembled	Width X [mm]	unassembled	assembled	Width X [mm]	unassembled	assembled
015	2300.015	2310.015	060	2300.060	2310.060	087	2300.087	2310.087
025	2300.025	2310.025	062	2300.062	2310.062	090	2300.090	2310.090
030	2300.030	2310.030	065	2300.065	2310.065	100	2300.100	2310.100
038	2300.038	2310.038	070	2300.070	2310.070	103	2300.103	2310.103
040	2300.040	2310.040	075	2300.075	2310.075	110	2300.110	2310.110
050	2300.050	2310.050	077	2300.077	2310.077	120	2300.120	2310.120
057	2300.057	2310.057	080	2300.080	2310.080	125	2300.125	2310.125

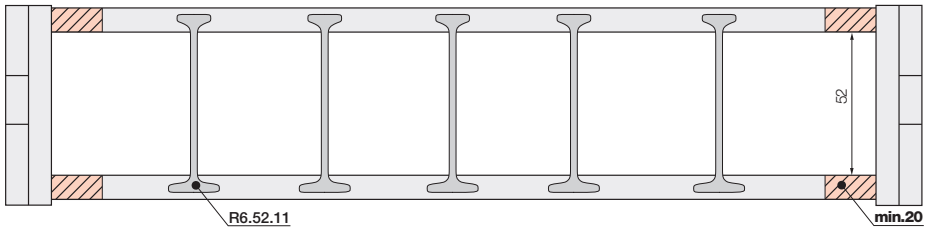

**Note:** Please observe a lateral spacing to the side links. **e-tube: 20 mm**  
In the standard configuration separators are assembled every 2<sup>nd</sup> e-chain® link.

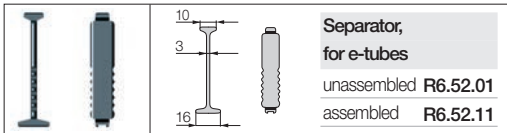

### Separator R6.52.01 (e-tubes only)

For e-tubes R6.52. The notches on this separator mark the side that fixes to the lid.



**Optional: Support tray tool kit.**

**For support of the lower run.**

Simple one-piece support trays according to your requirements and specification.  
The complete range with order options ► from page 714

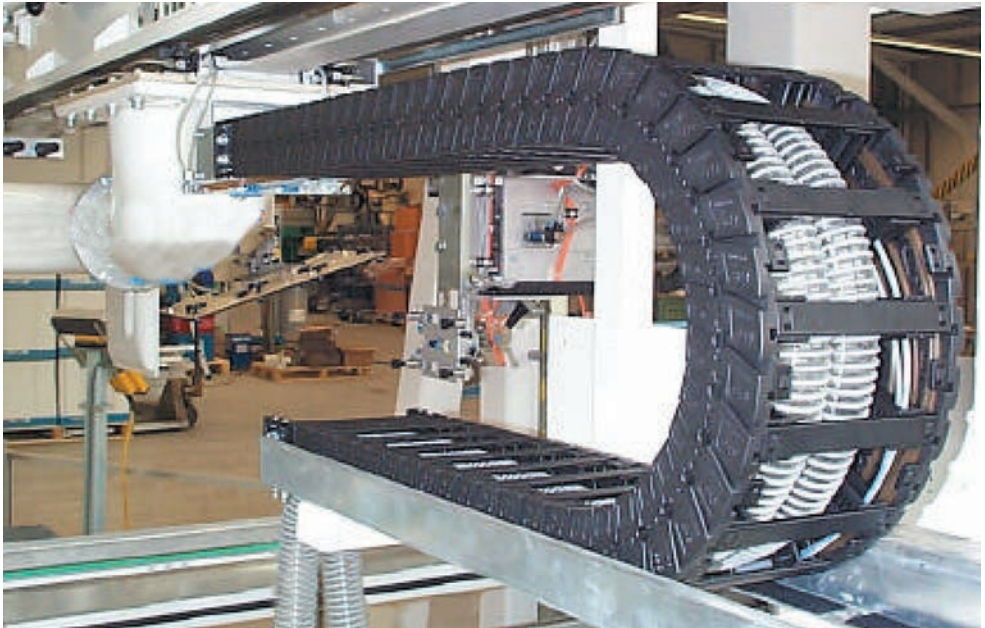

igus® System E6, pick and place robot - speed 8 m/s, acceleration 78,5 m/s<sup>2</sup>

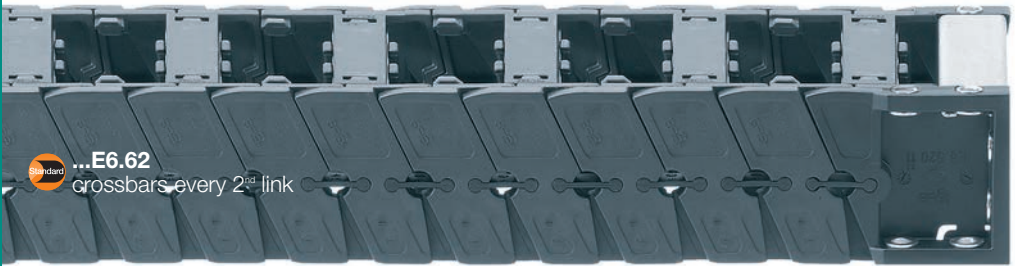

### e-chains® | Series E6.62 crossbars every 2<sup>nd</sup> link (crossbars removable along both radii)

Part No. e-chains®	<i>Bi</i> [mm]	<i>Ba</i> [mm]	E6.62 [kg/m]	Part No. e-chains®	<i>Bi</i> [mm]	<i>Ba</i> [mm]	E6.62 [kg/m]
E6.62.05. <i>R.0</i>	50	86	3,22	E6.62.212. <i>R.0</i>	212	248	3,78
E6.62.06. <i>R.0</i>	68	104	3,28	E6.62.23. <i>R.0</i>	225	261	3,83
E6.62.07. <i>R.0</i>	75	111	3,31	E6.62.237. <i>R.0</i>	237	273	3,87
E6.62.087. <i>R.0</i>	87	123	3,35	E6.62.25. <i>R.0</i>	250	286	3,91
E6.62.097. <i>R.0</i>	97	133	3,38	E6.62.262. <i>R.0</i>	262	298	3,95
E6.62.10. <i>R.0</i>	100	136	3,39	E6.62.28. <i>R.0</i>	275	311	4,00
E6.62.11. <i>R.0</i>	108	144	3,42	E6.62.29. <i>R.0</i>	287	323	4,04
E6.62.112. <i>R.0</i>	112	148	3,43	E6.62.30. <i>R.0</i>	300	336	4,09
E6.62.12. <i>R.0</i>	125	161	3,48	E6.62.312. <i>R.0</i>	312	348	4,13
E6.62.137. <i>R.0</i>	137	173	3,52	E6.62.325. <i>R.0</i>	325	361	4,17
E6.62.15. <i>R.0</i>	150	186	3,57	E6.62.337. <i>R.0</i>	337	373	4,21
E6.62.162. <i>R.0</i>	162	198	3,61	E6.62.350. <i>R.0</i>	350	386	4,26
E6.62.17. <i>R.0</i>	168	204	3,63	E6.62.362. <i>R.0</i>	362	398	4,30
E6.62.18. <i>R.0</i>	175	211	3,65	E6.62.375. <i>R.0</i>	375	411	4,35
E6.62.187. <i>R.0</i>	187	223	3,69	E6.62.387. <i>R.0</i>	387	423	4,39
E6.62.20. <i>R.0</i>	200	236	3,74	E6.62.400. <i>R.0</i>	400	436	4,43

Available bending radii *R* [mm] [115](#) | [150](#) | [200](#) | [250](#) | [300](#) | [350](#)

Supplement Part No. with required radius (*R*). Example:

E6.62.10.250.0 = e-chain® with crossbars every 2<sup>nd</sup> link, inner width *Bi* 100 mm, radius *R* 250 mm, color black

#### Optional: Support tray tool kit.

#### For support of the lower run.

Simple one-piece support trays according to your requirements and specification.

The complete range with order options ► from page 714





## Unsupported applications | Short travels

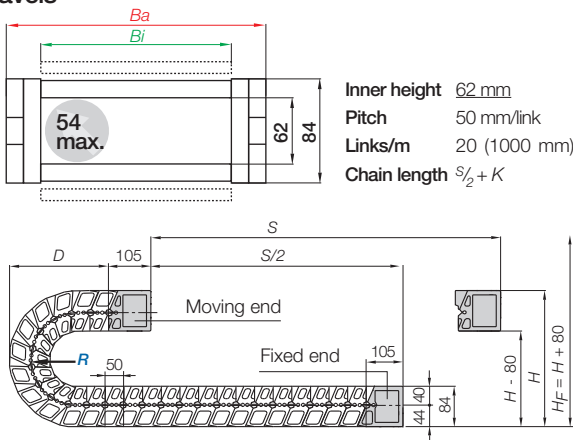
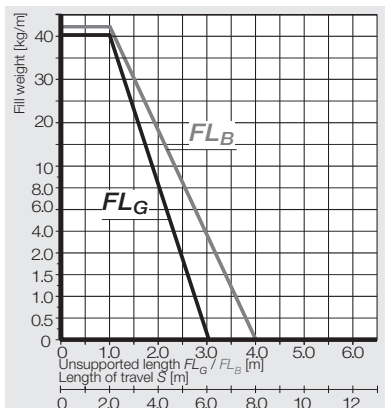

R	115	150	200	250	300	350
H	388	458	558	658	758	858
D	234	269	319	369	419	469
K	465	575	730	890	1045	1200

The required clearance height:  $H_F = H + 80$  mm (with 2,0 kg/m fill weight)



If you need this series for gliding applications, please consult igus®!

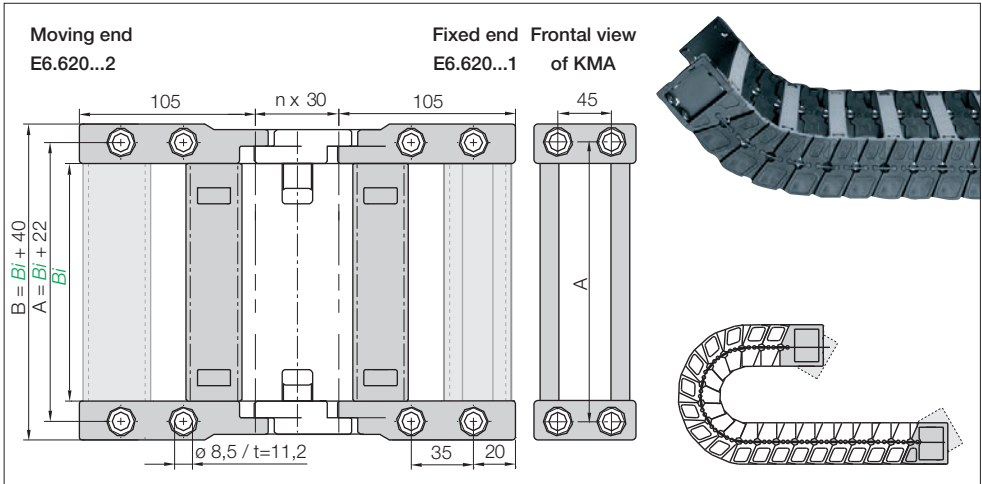

## KMA pivoting | Standard | Recommended for unsupported applications

Width Index	Part No. full set KMA pivoting: (optional with C-profile)	Dim A [mm]	Dim B [mm]	Bi [mm]	Width Index	Part No. full set KMA pivoting: (optional with C-profile)	Dim A [mm]	Dim B [mm]	Bi [mm]
05.	▶ E6.620.05. 12.C	72	90	50	212.	▶ E6.620.212.12.C	234	252	212
06.	▶ E6.620.06. 12.C	90	108	68	23.	▶ E6.620.23. 12.C	247	265	225
07.	▶ E6.620.07. 12.C	97	115	75	237.	▶ E6.620.237.12.C	259	277	237
087.	▶ E6.620.087.12.C	109	127	87	25.	▶ E6.620.25. 12.C	272	290	250
097.	▶ E6.620.097.12.C	119	137	97	262.	▶ E6.620.262.12.C	284	302	262
10.	▶ E6.620.10. 12.C	122	140	100	28.	▶ E6.620.28. 12.C	297	315	275
11.	▶ E6.620.11. 12.C	130	148	108	29.	▶ E6.620.29. 12.C	309	327	287
112.	▶ E6.620.112.12.C	134	152	112	30.	▶ E6.620.30. 12.C	322	340	300
12.	▶ E6.620.12. 12.C	147	165	125	312.	▶ E6.620.312.12.C	334	352	312
137.	▶ E6.620.137.12.C	159	177	137	325.	▶ E6.620.325.12.C	347	365	325
15.	▶ E6.620.15. 12.C	172	190	150	337.	▶ E6.620.337.12.C	359	377	337
162.	▶ E6.620.162.12.C	184	202	162	350.	▶ E6.620.350.12.C	372	390	350
17.	▶ E6.620.17. 12.C	190	208	168	362.	▶ E6.620.362.12.C	384	402	362
18.	▶ E6.620.18. 12.C	197	215	175	375.	▶ E6.620.375.12.C	397	415	375
187.	▶ E6.620.187.12.C	209	227	187	387.	▶ E6.620.387.12.C	409	427	387
20.	▶ E6.620.20. 12.C	222	240	200	400.	▶ E6.620.400.12.C	422	440	400

(KMA = Polymer Metal Mounting Bracket)

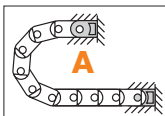

These attachment types are set automatically in the choice of the KMA mounting bracket. For the **preassembled** mode please add index **A**.

E6.620.10.12.CA	Part No. structure
	A... must be indicated on preassembled configurations
	C-profile option
	Full set
	Width index
	Series



**Strain relief** e.g. clamps, tie-wrap plates, nuggets and plug-in clips are available from stock. The complete chainfix range with order options ▶ from page 630

Interior separation | New generation

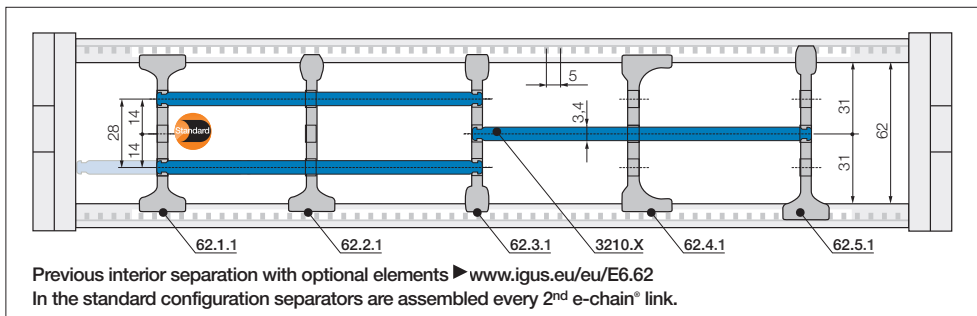
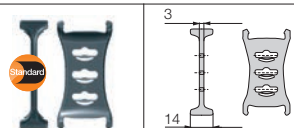



**Standard separator, wide base**

unassembled	<b>62.1</b>
assembled	<b>62.1.1</b>

**Standard - for all applications**

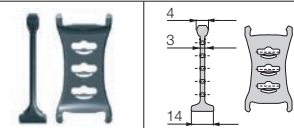
Separator with a wide base for maximum locking strength and safe standing in e-chains®.



**Separator for QuickLock crossbar**

unassembled	<b>62.2</b>
assembled	<b>62.2.1</b>

**For even faster installation**

Separator for igus® QuickLock crossbar 385.X.Q. Firm hold to one side with a wide base, narrow on opposed side for easy cable assembly (slight grip).

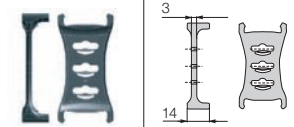

**Separator, asymmetrical\***

unassembled	<b>62.4</b>
assembled	<b>62.4.1</b>

**For side-mounted applications**

Asymmetrical separator, for defined distance. No additional spacers necessary for e-chains®. \*Available upon request, please consult igus® for delivery time!

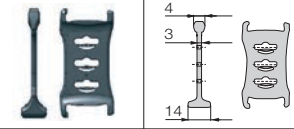

**Notch separator for notch crossbar\***

unassembled	<b>62.5</b>
assembled	<b>62.5.1</b>

**Locks safely in 5 mm increments**

Notch separator for the new notch crossbar, with scaling on the notch crossbars. For exact positioning in e-chains®. Recommended for side-mounted applications.

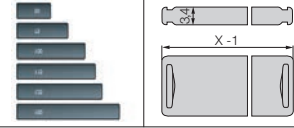

**Full-width shelf, lockable**

unassembled	<b>3200.X</b>
assembled	<b>3210.X</b>

**Horizontal separation**

Shelf locks safely into separators on both ends, fixed width possible. Separators can be moved freely over the shelf in horizontal direction. Can be arranged at 3 different heights.

**Lockable full-width shelves**



Width X [mm]	unassembled	assembled	Width X [mm]	unassembled	assembled	Width X [mm]	unassembled	assembled
050	3200.050	3210.050	125	3200.125	3210.125	225	3200.225	3210.225
075	3200.075	3210.075	150	3200.150	3210.150	250	3200.250	3210.250
100	3200.100	3210.100	175	3200.175	3210.175			
115	3200.115	3210.115	200	3200.200	3210.200			



...E6.80L  
crossbars every 2<sup>nd</sup> link

## e-chains® | Series E6.80L crossbars every 2<sup>nd</sup> link (crossbars removable along both radii)

Part No. e-chains®	<i>Bi</i> [mm]	<i>Ba</i> [mm]	E6.80L [kg/m]	Part No. e-chains®	<i>Bi</i> [mm]	<i>Ba</i> [mm]	E6.80L [kg/m]
E6.80L.08.R.0	87	101	3,28	E6.80L.32.R.0	325	339	4,38
E6.80L.10.R.0	100	114	3,33	E6.80L.33.R.0	337	351	4,44
E6.80L.11.R.0	112	126	3,38	E6.80L.35.R.0	350	364	4,50
E6.80L.12.R.0	125	139	3,43	E6.80L.36.R.0	362	376	4,56
E6.80L.13.R.0	137	151	3,49	E6.80L.37.R.0	375	389	4,62
E6.80L.15.R.0	150	164	3,55	E6.80L.38.R.0	387	401	4,68
E6.80L.16.R.0	162	176	3,61	E6.80L.40.R.0	400	414	4,74
E6.80L.17.R.0	175	189	3,67	E6.80L.41.R.0	412	426	4,80
E6.80L.18.R.0	187	201	3,73	E6.80L.42.R.0	425	439	4,85
E6.80L.20.R.0	200	214	3,79	E6.80L.43.R.0	437	451	4,92
E6.80L.21.R.0	212	226	3,85	E6.80L.45.R.0	450	464	5,03
E6.80L.22.R.0	225	239	3,91	E6.80L.46.R.0	462	476	5,09
E6.80L.23.R.0	237	251	3,97	E6.80L.47.R.0	475	489	5,15
E6.80L.25.R.0	250	264	4,02	E6.80L.48.R.0	487	501	5,21
E6.80L.26.R.0	262	276	4,09	E6.80L.50.R.0	500	514	5,27
E6.80L.27.R.0	275	289	4,14	E6.80L.51.R.0	512	526	5,33
E6.80L.28.R.0	287	301	4,20	E6.80L.52.R.0	525	539	5,39
E6.80L.30.R.0	300	314	4,26	E6.80L.53.R.0	537	551	5,45
E6.80L.31.R.0	312	326	4,32	E6.80L.55.R.0	550	564	5,51

\*Radius available upon request, please consult igus® for delivery time!

Available bending radii *R* [mm] 100\* | 150\* | 175 | 200\* | 250\* | 300\*

Supplement Part No. with required radius (*R*). Examples:

E6.80L.10.175.0 = e-chain® with crossbars every 2<sup>nd</sup> link, inner width *Bi* 100 mm, radius *R* 175 mm, color black

### Optional: Support tray tool kit.

#### For support of the lower run.

Simple one-piece support trays according to your requirements and specification.

The complete range with order options ► from page 714

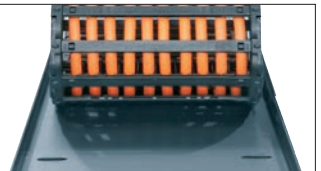



## Unsupported applications | Short travels

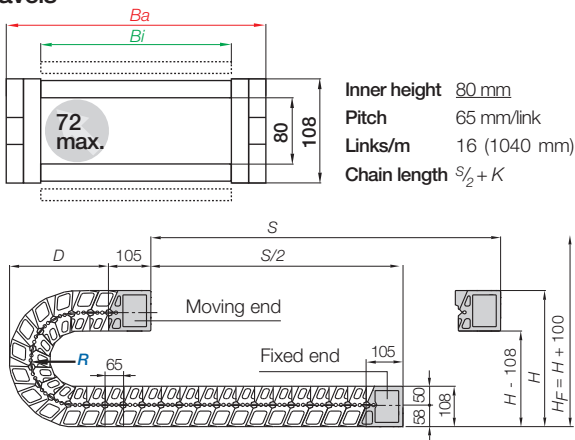
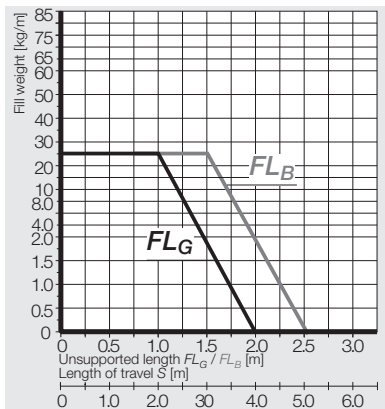

**Inner height** 80 mm  
**Pitch** 65 mm/link  
**Links/m** 16 (1040 mm)  
**Chain length**  $S/2 + K$

<b>R</b>	100*	150*	175	200*	250*	300*
<b>H</b>	316	416	466	516	616	716
<b>D</b>	256	307	331	356	406	456
<b>K</b>	445	605	680	760	920	1075

The required clearance height:  $H_F = H + 100$  mm (with 5,0 kg/m fill weight)

\*Radius available upon request, please consult igus\* for delivery time!



If you need this series for gliding applications, please consult igus®!

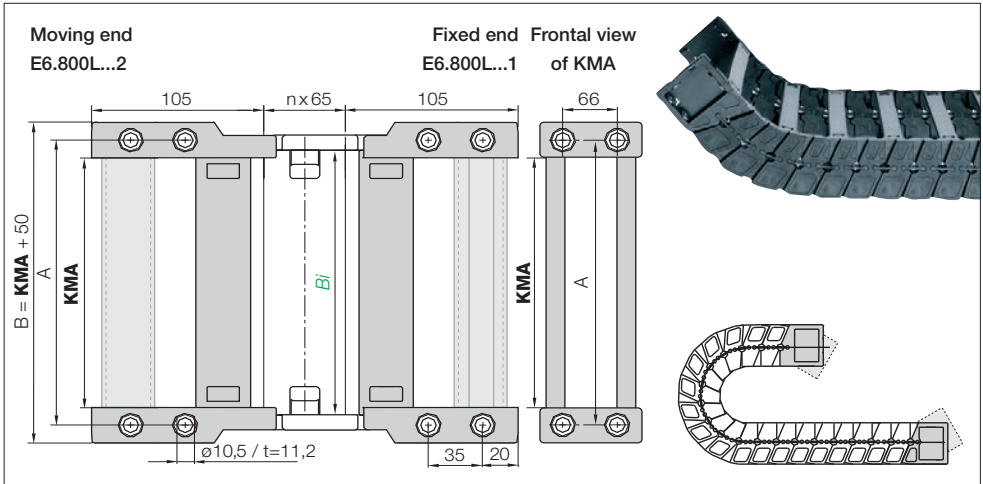

## KMA pivoting | Standard | Recommended for unsupported applications

Width Index	Part No. full set KMA pivoting: (optional with C-profile)	Dim A [mm]	KMA [mm]	Width Index	Part No. full set KMA pivoting: (optional with C-profile)	Dim A [mm]	KMA [mm]
08. ▶	E6.800L. 08. 12.C	103	75	32. ▶	E6.800L. 32. 12.C	340	312
10. ▶	E6.800L. 10. 12.C	115	87	33. ▶	E6.800L. 33. 12.C	353	325
11. ▶	E6.800L. 11. 12.C	128	100	35. ▶	E6.800L. 35. 12.C	365	337
12. ▶	E6.800L. 12. 12.C	140	112	36. ▶	E6.800L. 36. 12.C	378	350
13. ▶	E6.800L. 13. 12.C	153	125	37. ▶	E6.800L. 37. 12.C	390	362
15. ▶	E6.800L. 15. 12.C	165	137	38. ▶	E6.800L. 38. 12.C	403	375
16. ▶	E6.800L. 16. 12.C	178	150	40. ▶	E6.800L. 40. 12.C	415	387
17. ▶	E6.800L. 17. 12.C	190	162	41. ▶	E6.800L. 41. 12.C	428	400
18. ▶	E6.800L. 18. 12.C	203	175	42. ▶	E6.800L. 42. 12.C	440	412
20. ▶	E6.800L. 20. 12.C	215	187	43. ▶	E6.800L. 43. 12.C	453	425
21. ▶	E6.800L. 21. 12.C	228	200	45. ▶	E6.800L. 45. 12.C	465	437
22. ▶	E6.800L. 22. 12.C	240	212	46. ▶	E6.800L. 46. 12.C	478	450
23. ▶	E6.800L. 23. 12.C	253	225	47. ▶	E6.800L. 47. 12.C	490	462
25. ▶	E6.800L. 25. 12.C	265	237	48. ▶	E6.800L. 48. 12.C	503	475
26. ▶	E6.800L. 26. 12.C	278	250	50. ▶	E6.800L. 50. 12.C	515	487
27. ▶	E6.800L. 27. 12.C	290	262	51. ▶	E6.800L. 51. 12.C	528	500
28. ▶	E6.800L. 28. 12.C	303	275	52. ▶	E6.800L. 52. 12.C	540	512
30. ▶	E6.800L. 30. 12.C	315	287	53. ▶	E6.800L. 53. 12.C	553	225
31. ▶	E6.800L. 31. 12.C	328	300	55. ▶	E6.800L. 55. 12.C	565	537

(KMA = Polymer Metal Mounting Bracket)

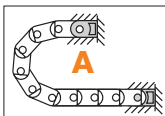

These attachment types are set automatically in the choice of the KMA mounting bracket.  
For the **preassembled** mode please add index **A**.

**E6.800L.10.12.CA** Part No. structure

- A... must be indicated on preassembled configurations
- C-profile option
- Full set
- Width index
- Series



**Strain relief** e.g. clamps, tiewrap plates, nuggets and plug-in clips are available from stock. The complete chainfix range with order options ▶ from page 630



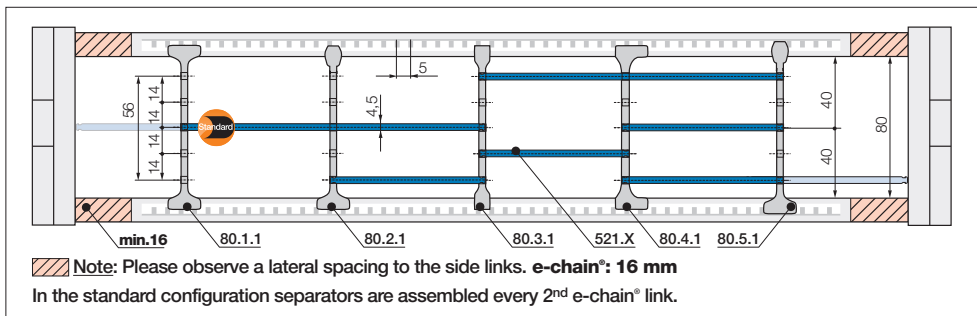

**Standard separator, wide base**

unassembled	80.1
assembled	80.1.1

**Standard - for all applications**

Separator with a wide base for maximum locking strength and safe standing in e-chains® and e-tubes.

**Separator for QuickLock crossbar**

unassembled	80.2
assembled	80.2.1

**For even faster installation**

Separator for igus® QuickLock crossbar 450.X.Q. Firm hold to one side with a wide base, narrow on opposed side for easy cable assembly (slight grip). For e-tubes also.

**Separator, narrow base**

unassembled	80.3
assembled	80.3.1

**For many thin cables**

Separator with a narrow base for a large number of thin cables side by side. Saves space in e-chains® and e-tubes. Also available for QuickLock crossbars.

**Separator, asymmetrical**

unassembled	80.4
assembled	80.4.1

**For side-mounted applications**

Asymmetrical separator, for defined distance. No additional spacers necessary for e-chains® and e-tubes.

**Notch separator for notch crossbar**

unassembled	80.5
assembled	80.5.1

**Locks safely in 5 mm increments**

Notch separator for the new notch crossbar, with scaling on the notch crossbars. For exact positioning in e-chains® and e-tubes. Recommended for side-mounted applications.

**Full-width shelf, lockable**

unassembled	520.X
assembled	521.X

**Horizontal separation**

Shelf locks safely into separators on both ends, fixed width possible. Separators can be moved freely over the shelf in horizontal direction. Can be arranged at 5 different heights.

**Lockable full-width shelves**



Width X [mm]	unassembled	assembled	Width X [mm]	unassembled	assembled	Width X [mm]	unassembled	assembled
050	520.050	521.050	125	520.125	521.125	225	520.225	521.225
065	520.065	521.065	150	520.150	521.150	250	520.250	521.250
075	520.075	521.075	175	520.175	521.175	300	520.300	521.300
100	520.100	521.100	200	520.200	521.200	450	520.450	521.450



### e-chains® | Series E6.80 crossbars every 2<sup>nd</sup> link (crossbars removable along both radii)

Part No. e-chains®	<i>Bi</i> [mm]	<i>Ba</i> [mm]	E6.80 [kg/m]	Part No. e-chains®	<i>Bi</i> [mm]	<i>Ba</i> [mm]	E6.80 [kg/m]
E6.80.05. <i>R.0</i>	50	100	5,21	E6.80.31. <i>R.0</i>	312	362	6,45
E6.80.06. <i>R.0</i>	65	115	5,28	E6.80.32. <i>R.0</i>	325	375	6,51
E6.80.07. <i>R.0</i>	75	125	5,33	E6.80.33. <i>R.0</i>	337	387	6,57
E6.80.08. <i>R.0</i>	87	137	5,38	E6.80.35. <i>R.0</i>	350	400	6,63
E6.80.10. <i>R.0</i>	100	150	5,45	E6.80.36. <i>R.0</i>	362	412	6,69
E6.80.11. <i>R.0</i>	112	162	5,50	E6.80.37. <i>R.0</i>	375	425	6,75
E6.80.12. <i>R.0</i>	125	175	5,57	E6.80.38. <i>R.0</i>	387	437	6,80
E6.80.13. <i>R.0</i>	137	187	5,62	E6.80.40. <i>R.0</i>	400	450	6,88
E6.80.15. <i>R.0</i>	150	200	5,68	E6.80.41. <i>R.0</i>	412	462	6,92
E6.80.16. <i>R.0</i>	162	212	5,74	E6.80.42. <i>R.0</i>	425	475	6,99
E6.80.17. <i>R.0</i>	175	225	5,80	E6.80.43. <i>R.0</i>	437	487	7,04
E6.80.18. <i>R.0</i>	187	237	5,86	E6.80.45. <i>R.0</i>	450	500	7,10
E6.80.20. <i>R.0</i>	200	250	5,92	E6.80.46. <i>R.0</i>	462	512	7,16
E6.80.21. <i>R.0</i>	212	262	5,98	E6.80.47. <i>R.0</i>	475	525	7,22
E6.80.22. <i>R.0</i>	225	275	6,04	E6.80.48. <i>R.0</i>	487	537	7,28
E6.80.23. <i>R.0</i>	237	287	6,10	E6.80.50. <i>R.0</i>	500	550	7,34
E6.80.25. <i>R.0</i>	250	300	6,16	E6.80.51. <i>R.0</i>	512	562	7,40
E6.80.26. <i>R.0</i>	262	312	6,21	E6.80.52. <i>R.0</i>	525	575	7,46
E6.80.27. <i>R.0</i>	275	325	6,28	E6.80.53. <i>R.0</i>	537	587	7,52
E6.80.28. <i>R.0</i>	287	337	6,33	E6.80.55. <i>R.0</i>	550	600	7,58
E6.80.30. <i>R.0</i>	300	350	6,39	E6.80.60. <i>R.0</i>	600	650	7,81

Available bending radii *R* [mm] 150 | 200 | 250 | 300 | 350 | 400 | 450

Supplement Part No. with required radius (*R*). Examples:

E6.80.10.300.0 = e-chain® with crossbars every 2<sup>nd</sup> link, inner width *Bi* 100 mm, radius *R* 300 mm, color black

#### Optional: Support tray tool kit.

#### For support of the lower run.

Simple one-piece support trays according to your requirements and specification.

The complete range with order options ► from page 714





## Unsupported applications | Short travels

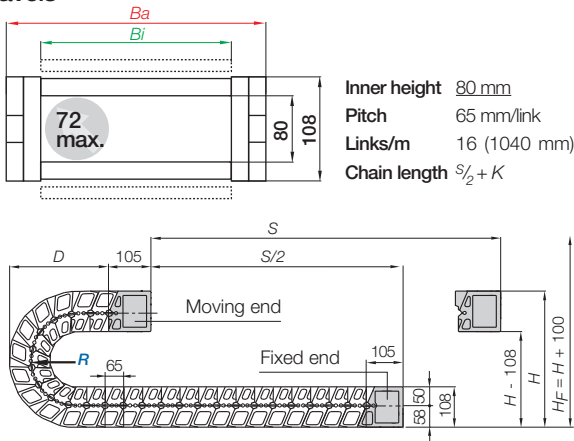
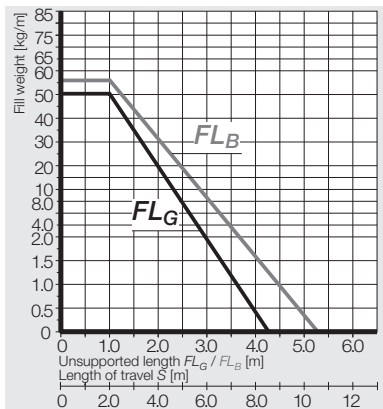

	150	200	250	300	350	400	450
<b>R</b>	150	200	250	300	350	400	450
<b>H</b>	516	616	716	816	916	1016	1116
<b>D</b>	306	356	406	456	506	556	606
<b>K</b>	605	760	920	1075	1230	1390	1545

The required clearance height:  $H_F = H + 100$  mm (with 5,0 kg/m fill weight)



If you need this series for gliding applications, please consult igus®!

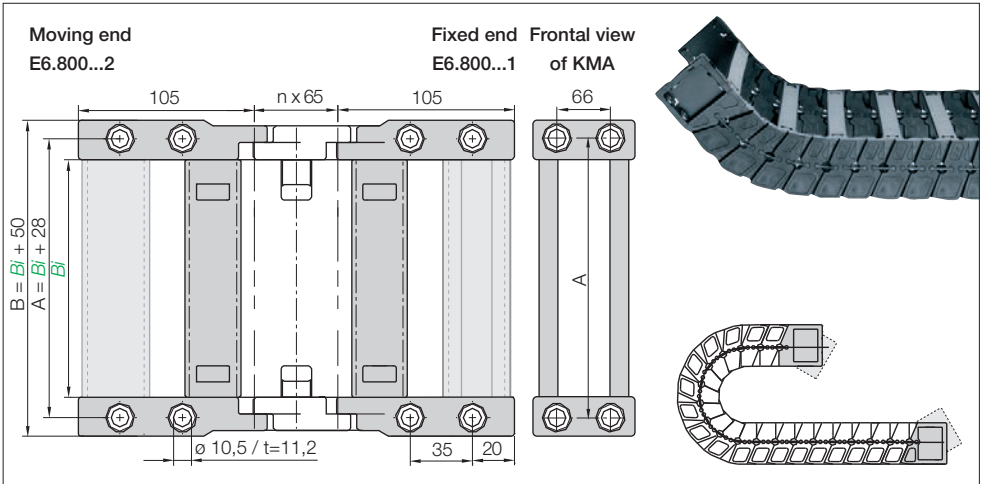

## KMA pivoting | Standard | Recommended for unsupported applications

Width Index	Part No. full set KMA pivoting: (optional with C-profile)	Dim A [mm]	Dim B [mm]	Bi [mm]	Width Index	Part No. full set KMA pivoting: (optional with C-profile)	Dim A [mm]	Dim B [mm]	Bi [mm]
05. ▶	E6.800.05.12.C	78	100	50	31. ▶	E6.800.31.12.C	340	362	312
06. ▶	E6.800.06.12.C	93	115	65	32. ▶	E6.800.32.12.C	353	375	325
07. ▶	E6.800.07.12.C	103	125	75	33. ▶	E6.800.33.12.C	365	387	337
08. ▶	E6.800.08.12.C	115	137	87	35. ▶	E6.800.35.12.C	378	400	350
10. ▶	E6.800.10.12.C	128	150	100	36. ▶	E6.800.36.12.C	390	412	362
11. ▶	E6.800.11.12.C	140	162	112	37. ▶	E6.800.37.12.C	403	425	375
12. ▶	E6.800.12.12.C	153	175	125	38. ▶	E6.800.38.12.C	415	437	387
13. ▶	E6.800.13.12.C	165	187	137	40. ▶	E6.800.40.12.C	428	450	400
15. ▶	E6.800.15.12.C	178	200	150	41. ▶	E6.800.41.12.C	440	462	412
16. ▶	E6.800.16.12.C	190	212	162	42. ▶	E6.800.42.12.C	453	475	425
17. ▶	E6.800.17.12.C	203	225	175	43. ▶	E6.800.43.12.C	465	487	437
18. ▶	E6.800.18.12.C	215	237	187	45. ▶	E6.800.45.12.C	478	500	450
20. ▶	E6.800.20.12.C	228	250	200	46. ▶	E6.800.46.12.C	490	512	462
21. ▶	E6.800.21.12.C	240	262	212	47. ▶	E6.800.47.12.C	503	525	475
22. ▶	E6.800.22.12.C	253	275	225	48. ▶	E6.800.48.12.C	515	537	487
23. ▶	E6.800.23.12.C	265	287	237	50. ▶	E6.800.50.12.C	528	550	500
25. ▶	E6.800.25.12.C	278	300	250	51. ▶	E6.800.51.12.C	540	562	512
26. ▶	E6.800.26.12.C	290	412	262	52. ▶	E6.800.52.12.C	553	575	525
27. ▶	E6.800.27.12.C	303	325	275	53. ▶	E6.800.53.12.C	565	587	537
28. ▶	E6.800.28.12.C	315	337	287	55. ▶	E6.800.55.12.C	578	600	550
30. ▶	E6.800.30.12.C	328	350	300	60. ▶	E6.800.60.12.C	628	650	600

(KMA = Polymer Metal Mounting Bracket)

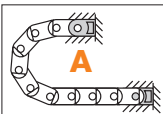
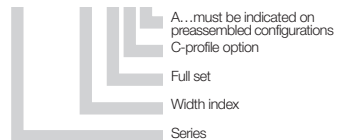

## E6.800.10.12.CA Part No. structure



These attachment types are set automatically in the choice of the KMA mounting bracket. For the **preassembled** mode please add index **A**.

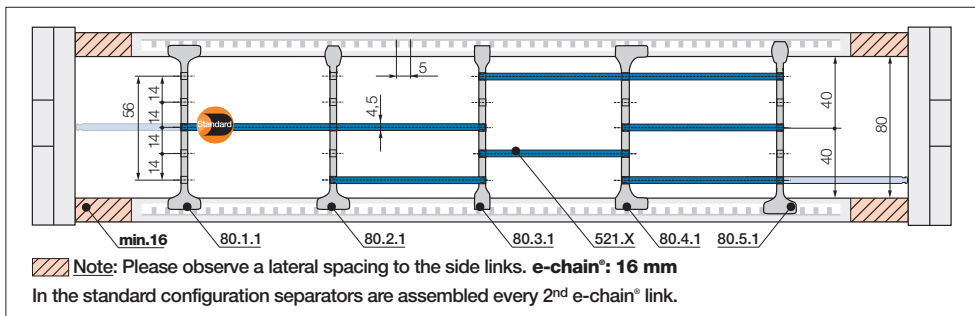

**Strain relief** e.g. clamps, tiewrap plates, nuggets and plug-in clips are available from stock. The complete chainfix range with order options ▶ from page 630

**Standard separator, wide base**

unassembled	80.1
assembled	80.1.1

**Standard - for all applications**  
 Separator with a wide base for maximum locking strength and safe standing in e-chains® and e-tubes.



**Separator for QuickLock crossbar**

unassembled	80.2
assembled	80.2.1

**For even faster installation**  
 Separator for igus® QuickLock crossbar 450.X.Q. Firm hold to one side with a wide base, narrow on opposed side for easy cable assembly (slight grip). For e-tubes also.



**Separator, narrow base**

unassembled	80.3
assembled	80.3.1

**For many thin cables**  
 Separator with a narrow base for a large number of thin cables side by side. Saves space in e-chains® and e-tubes. Also available for QuickLock crossbars.



**Separator, asymmetrical**

unassembled	80.4
assembled	80.4.1

**For side-mounted applications**  
 Asymmetrical separator, for defined distance. No additional spacers necessary for e-chains® and e-tubes.



**Notch separator for notch crossbar**

unassembled	80.5
assembled	80.5.1

**Locks safely in 5 mm increments**  
 Notch separator for the new notch crossbar, with scaling on the notch crossbars. For exact positioning in e-chains® and e-tubes. Recommended for side-mounted applications.



**Full-width shelf, lockable**

unassembled	520.X
assembled	521.X

**Horizontal separation**  
 Shelf locks safely into separators on both ends, fixed width possible. Separators can be moved freely over the shelf in horizontal direction. Can be arranged at 5 different heights.

Lockable full-width shelves	Width X [mm]		Width X [mm]		Width X [mm]	
	unassembled	assembled	unassembled	assembled	unassembled	assembled
	050	520.050	521.050	125	520.125	521.125
	065	520.065	521.065	150	520.150	521.150
	075	520.075	521.075	175	520.175	521.175
	100	520.100	521.100	200	520.200	521.200
				225	520.225	521.225
			250	520.250	521.250	
			300	520.300	521.300	
			450	520.450	521.450	

# E6.1 - Smoother running, easier to open, for cleanrooms

The E6.1 series is an advancement of the E6 series. While having all its advantages, like the stability and clean room suitability, it is even lighter, faster and quieter. In addition, its accessibility to the interior and the assembly and handling have been improved.

- Crossbars are openable on both sides (Series E61.29) and removable in the inner and outer radius
- Option without camber NC by turning the inner link
- Extremely quiet through small pitch and brake in the stop-dog system
- Extremely low vibration
- Low-abrasion link system (no pin/hole connection)
- Virtually no polygon effect, thereby "smooth rolling" operation
- Faster lengthening and shortening through optimized connection design
- Smooth and obstacle free interior design for a long lifetime for cables and hoses
- Weight savings approx. 30% compared to the System E6
- Cost-effective

## Typical industries and applications

- Semiconductor industry
- Printer industry
- Applications with highest accelerations and where noise minimization and low abrasion are important

Universal: Attachment on all sides

Quick assembly: Removable crossbars along inner/outer radius

Very low noise: Small pitch for low-noise, smooth operation

Dynamic: For high speed and high accelerations

Long service life: Minimum vibration, high stability and tensile strength

Virtually no wear: Polymer spring - No pin and bore connection

Modular design: Can be shortened and lengthened

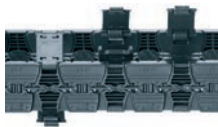

Specialty Series E61.29: Openable crossbars on both sides



Extremely low noise



Clean room tests upon request



# E6.1 | Features | Accessories



New generation interior separation - even more cable-friendly

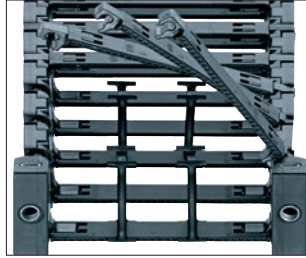

New snap-open mechanism, Series E61.29 choice of snap-open on left or right

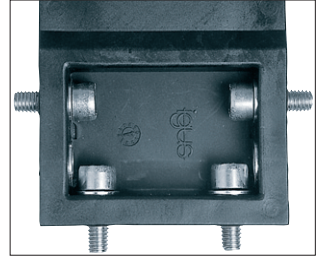

KMA mounting brackets with attachment options on all sides

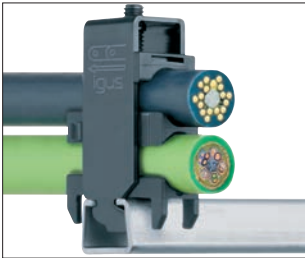

Strain relief e.g. clamps, tiwrap plates, nugs and plug-in clips ► from page 630



Pivoting and locking KMA mounting brackets are available



Support tray tool kit. For support of the lower run ► from page 714

## System E6.1 internal tests in the igus® lab

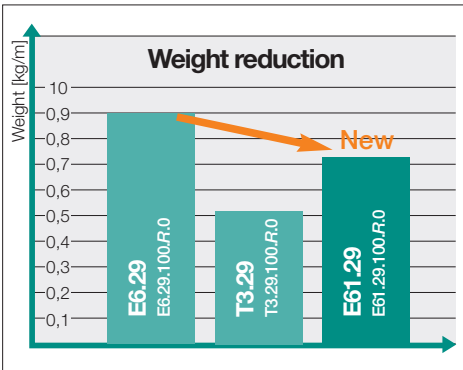

The new E6.1 generation can take up higher accelerations, due to a weight reduction, making it a highly dynamic yet still extremely quiet e-chain®

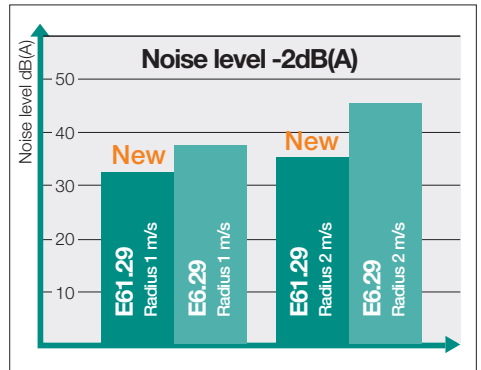

Series E61.29 tests in the igus® test lab show noise levels, which are 2 dB(A) below the already class-leading noise-levels of the igus® E6.29 series

# E6.1 | Selection Table | Technical Data | Overview

Series	Inner height <i>hi</i> [mm]	Inner width <i>Bi</i> [mm]	Outer width <i>Ba</i> [mm]	Outer height <i>ha</i> [mm]	Bending radius <i>R</i> [mm]	Unsupported max. length [m]	Page
--------	--------------------------------	-------------------------------	-------------------------------	--------------------------------	---------------------------------	--------------------------------	------

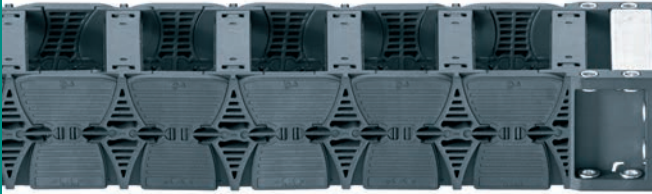

## System E6.1

Crossbars removable  
along both radii

<b>E61.29 New*</b>	29	30 - 140	44 - 144	35	55 - 150	≈ 1,5	<b>536</b>
<b>E61.52 New*</b>	52	40 - 300	64 - 324	65	75 - 200	≈ 1,7	<b>540</b>

\* in this catalog

## Technical Data

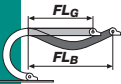

Speed / acceleration  $FL_G$  max. max. 20 [m/s] / max. 200 [m/s<sup>2</sup>]

Speed / acceleration  $FL_B$  max. max. 3 [m/s] / max. 6 [m/s<sup>2</sup>]



Permitted temperature °C -40° up to +70° C



Flammability class VDE 0304 IIC UL94-HB

■  $FL_G$  = with straight upper run ■  $FL_B$  = with permitted sag

## Installation methods overview, maximum travels

e-chain® Series	 Unsupported application	 Vertical hanging	 Vertical standing
E61.29	≤ 1,5 m	≤ 25 m	≤ 2,0 m
E61.52	≤ 2,5 m	≤ 40 m	≤ 2,0 m



# E6.1 | Order keys and Options

## Options with order keys based on Series E61.52



Standard

Part No.  
Standard  
e-chains®



E61.52.100.R.0



Delivery  
from stock

NC-Version - (no camber)  
Simply turn inner side link  
without additional work

Part No.  
NC-Version  
e-chains®

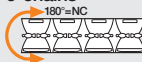

E61.52.100.R.0.NC

Delivery  
from stock

## Order example | Order key and color options based on Series E61.52



Order example for complete e-chain® (1,0 m),  
color black, with mounting brackets and interior separation:

e-chain® (1,0 m) Please indicate e-chain® length or number of links: 1,0 m or 34 links **E61.52.100.075.0**

+ Mounting brackets KMA, pivoting - 1set **E61.520.100.12**

+ Interior separation with 2 separators assembled every 2<sup>nd</sup> link **2 x 52.1.1**

Order text: 1,0 m E61.52.100.075.0 + E61.520.100.12 + 2 x 52.1.1



### Order key

e-chain® crossbars **E61.52.100.075.0**  
removable along both radii:

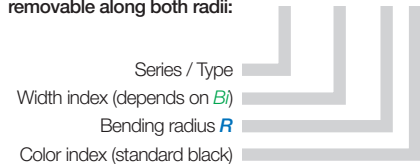

### General igus® color options for e-chains® and e-tubes

Color	Order index	Color	Order index
Black Standard, from stock!	.0	White special color	.1
Slate grey only ESD material	.ESD	Gray white special color	.1S
Gray brown only HT material	.HT	Orange special color	.2
Gray special color only e-chains®	.3	Yellow special color	.4
Dusty grey special color only e-tubes	.31	Light grey special color	.14

Black e-chains® available from stock!

Delivery time for special colors: upon request

E61.52.100.075.0 = with inner width **B** 100 mm, radius **R** 75 mm, color black

Extremely low-noise, minimum vibration, medium size

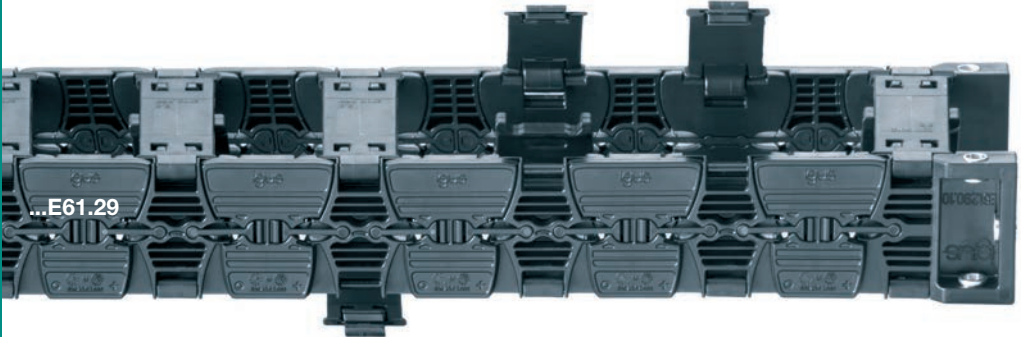

## e-chains® | Series E61.29 | Cross-chains removable along both radii

Part No. e-chains®	<i>Bi</i> [mm]	<i>Ba</i> [mm]	E61.29 [kg/m]	Part No. e-chains®	<i>Bi</i> [mm]	<i>Ba</i> [mm]	E61.29 [kg/m]
E61.29. 030 <i>R.0</i>	30	44	0,558	E61.29. 090 <i>R.0</i>	90	104	0,707
E61.29. 040 <i>R.0</i>	40	54	0,583	E61.29. 100 <i>R.0</i>	100	114	0,732
E61.29. 050 <i>R.0</i>	50	64	0,608	E61.29. 110 <i>R.0</i>	110	124	0,757
E61.29. 060 <i>R.0</i>	60	74	0,633	E61.29. 120 <i>R.0</i>	120	134	0,782
E61.29. 070 <i>R.0</i>	70	84	0,657	E61.29. 140 <i>R.0</i>	140	144	0,807
E61.29. 080 <i>R.0</i>	80	94	0,682				

Available bending radii *R* [mm] 055 | 075 | 100 | 125 | 150 |Supplement Part No. with required radius (*R*). Examples:E61.29.050.100.0 = e-chain® with inner width *Bi* 50 mm, radius *R* 100 mm, color black

## Dimensions

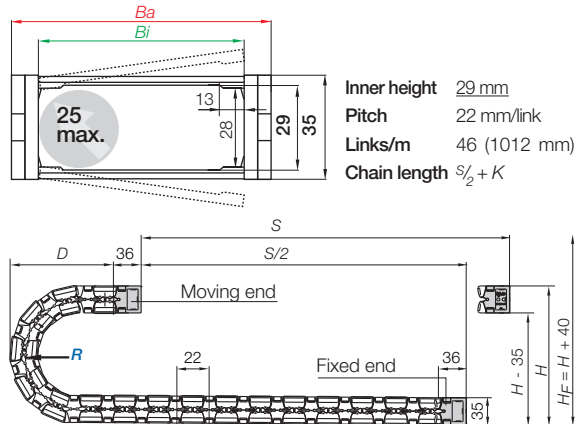
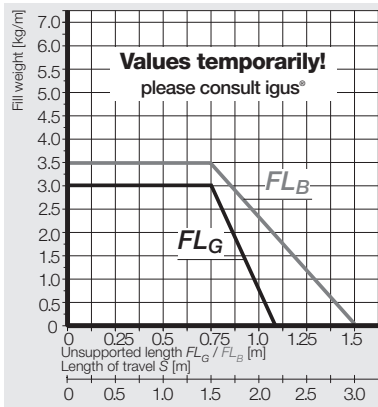

<i>R</i>	55	75	100	125	150
<i>H</i>	175	215	265	315	365
<i>D</i>	105,5	125,5	150,5	175,5	200,5
<i>K</i>	220	280	360	440	520

The required clearance height:  $H_F = H + 40$  mm (with 2,0 kg/m fill weight)



## KMA mounting brackets | Attachment on all sides | pivoting

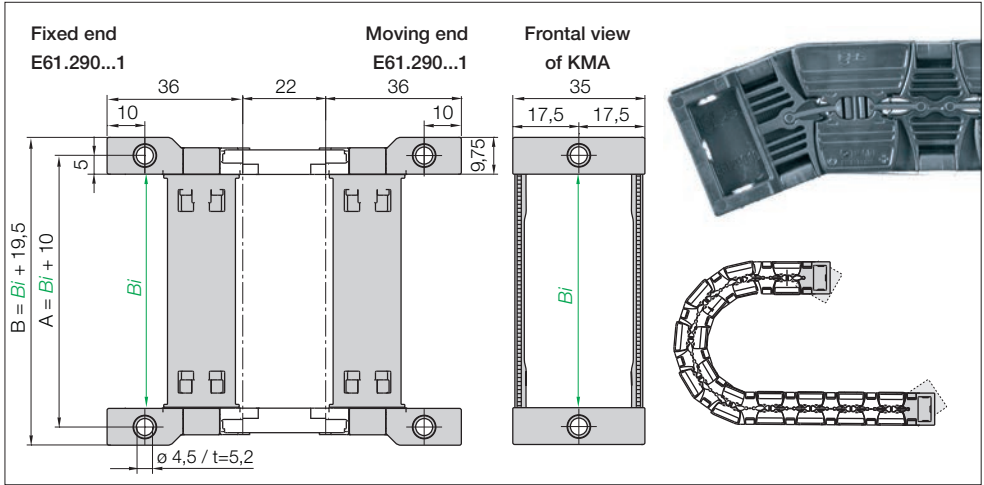

### KMA pivoting | Standard | Recommended for unsupported applications

Width Index	Part No. full set <b>KMA pivoting:</b>	Dim A [mm]	Dim B [mm]	Bi [mm]	Width Index	Part No. full set <b>KMA pivoting:</b>	Dim A [mm]	Dim B [mm]	Bi [mm]
030 ▶	<b>E61.290.030. 12</b>	40	49,5	<b>30</b>	090* ▶	<b>E61.290.090. 12</b>	100	109,5	<b>90</b>
040 ▶	<b>E61.290.040. 12</b>	50	59,5	<b>40</b>	100 ▶	<b>E61.290.100. 12</b>	110	119,5	<b>100</b>
050 ▶	<b>E61.290.050. 12</b>	60	69,5	<b>50</b>	110* ▶	<b>E61.290.110. 12</b>	120	129,5	<b>110</b>
060 ▶	<b>E61.290.060. 12</b>	70	79,5	<b>60</b>	120 ▶	<b>E61.290.120. 12</b>	130	139,5	<b>120</b>
070 ▶	<b>E61.290.070. 12</b>	80	89,5	<b>70</b>	140 ▶	<b>E61.290.140. 12</b>	140	149,5	<b>140</b>
080 ▶	<b>E61.290.080. 12</b>	90	99,5	<b>80</b>					

(KMA = Polymer Metal Mounting Bracket)

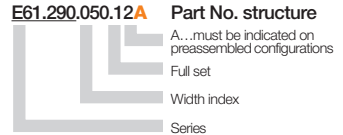
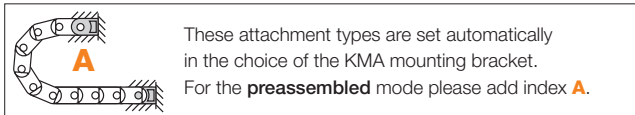

 **Strain relief** e.g. clamps, tiewrap plates, nuggets and plug-in clips are available from stock. The complete chainfix range with order options ▶ from page 630

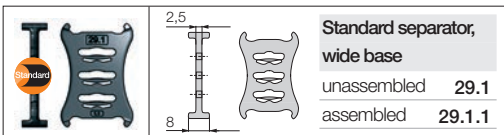
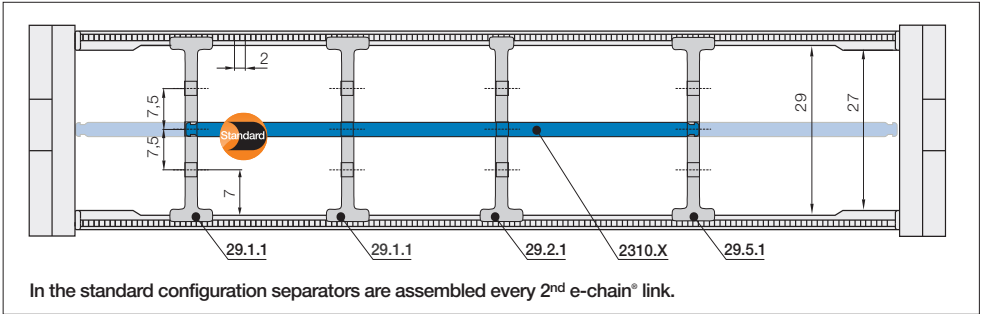

### Standard - for all applications

Separator with a wide base for maximum locking strength and safe standing in e-chains®.

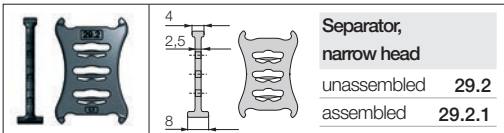

### For even faster installation

Firm hold to one side with a wide base, narrow on opposed side for easy cable assembly (slight grip).

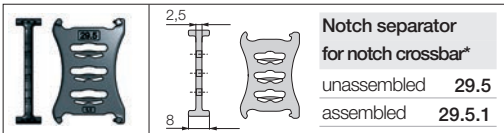

### Locks safely in 2 mm increments

Notch separator for exact positioning in e-chains®. Recommended for side-mounted applications.

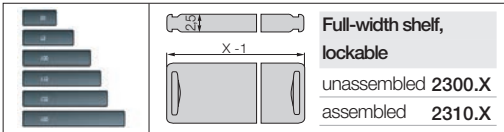

### Horizontal separation

Shelf locks safely into separators on both ends, fixed width possible. Separators can be moved freely over the shelf in horizontal direction. Can be arranged at 3 different heights.

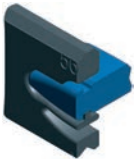

### Lockable full-width shelves - for the standard interior separation

Width X [mm]	unassembled	assembled	Width X [mm]	unassembled	assembled	Width X [mm]	unassembled	assembled
015	2300.015	2310.015	060	2300.060	2310.060	087	2300.087	2310.087
025	2300.025	2310.025	062	2300.062	2310.062	090	2300.090	2310.090
030	2300.030	2310.030	065	2300.065	2310.065	100	2300.100	2310.100
038	2300.038	2310.038	070	2300.070	2310.070	103	2300.103	2310.103
040	2300.040	2310.040	075	2300.075	2310.075	110	2300.110	2310.110
050	2300.050	2310.050	077	2300.077	2310.077	120	2300.120	2310.120
057	2300.057	2310.057	080	2300.080	2310.080	125	2300.125	2310.125



Series E61.29 crossbars can be opened along the inner and outer radius

### Separator with integrated strain relief

**Strain relief separator Part No. E61.29.02.Z** can be integrated into the mounting bracket and can be placed there at any point of the e-chain®. It combines strain relief and interior separation ● For the use in the first or last chain link ● Easy to assemble without any screws. **Further Information ► from page 650**



### Optional: Support tray tool kit.

#### For support of the lower run.

Simple one-piece support trays according to your requirements and specification. **The complete range with order options ► from page 714**



Extremely low-noise, minimum vibration, medium size

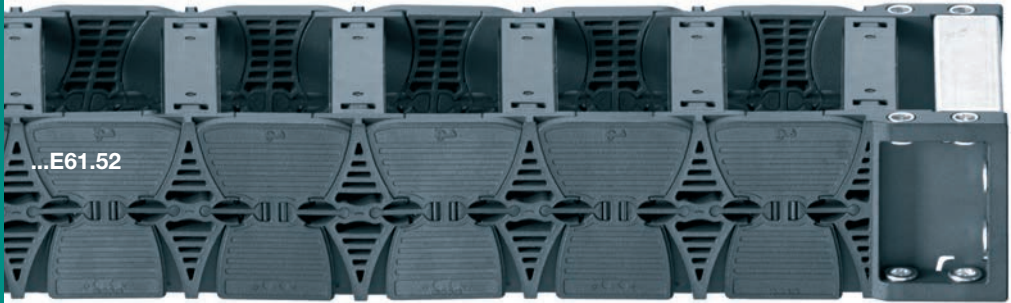

## e-chains® | Series E61.52 | Crossbars removable along both radii

Part No. e-chains®	<i>Bi</i> [mm]	<i>Ba</i> [mm]	E61.52 [kg/m]	Part No. e-chains®	<i>Bi</i> [mm]	<i>Ba</i> [mm]	E61.52 [kg/m]
E61.52. 040 <i>R.0</i>	40	64	≈ 1,68	E61.52. 150 <i>R.0</i>	150	174	≈ 2,17
E61.52. 050 <i>R.0</i>	50	74	≈ 1,72	E61.52. 175 <i>R.0</i>	175	199	≈ 2,28
E61.52. 052 <i>R.0</i>	52	76	≈ 1,73	E61.52. 200 <i>R.0</i>	200	224	≈ 2,40
E61.52. 062 <i>R.0</i>	62,5	86,5	≈ 1,78	E61.52. 225 <i>R.0</i>	225	249	≈ 2,50
E61.52. 070 <i>R.0</i>	70	94	≈ 1,81	E61.52. 250 <i>R.0</i>	250	274	≈ 2,62
E61.52. 075 <i>R.0</i>	75	99	≈ 1,84	E61.52. 262 <i>R.0</i>	262,5	286,5	≈ 2,68
E61.52. 087 <i>R.0</i>	87,5	111,5	≈ 1,89	E61.52. 275 <i>R.0</i>	275	299	≈ 2,73
E61.52. 100 <i>R.0</i>	100	124	≈ 1,95	E61.52. 300 <i>R.0</i>	300	324	≈ 2,84
E61.52. 125 <i>R.0</i>	125	149	≈ 2,06				

\*Radius available upon request, please consult igus® for delivery time!

Available bending radii *R* [mm] 075 | 100\* | 125 | 150\* | 175\* | 200\* |Supplement Part No. with required radius (*R*). Examples:E61.52.100.075.0 = e-chain® with inner width *Bi* 100 mm, radius *R* 75 mm, color black



## Unsupported applications | Short travels

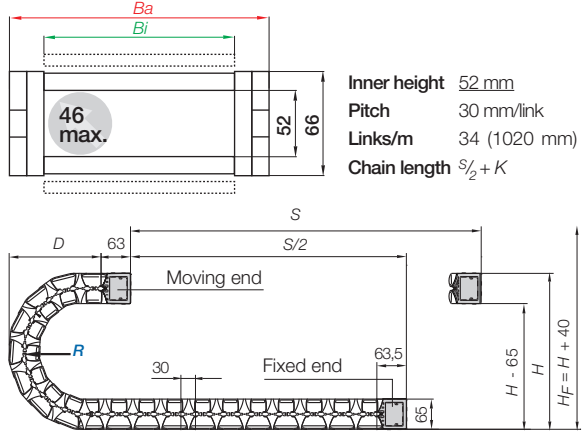
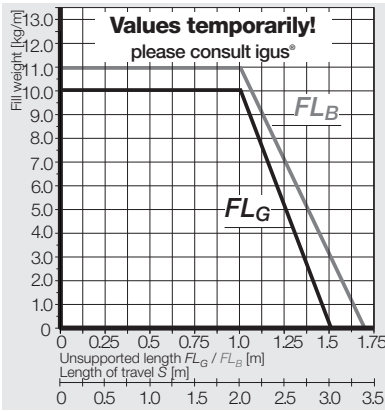

<b>R</b>	075	100*	125	150*	175*	200*
<b>H</b>	265	315	365	415	465	515
<b>D</b>	152,5	177,5	202,5	227,5	252,5	277,5
<b>K</b>	300	375	455	535	610	690

The required clearance height:  $H_F = H + 40$  mm (with 2,0 kg/m fill weight)

\*Radius available upon request, please consult igus® for delivery time!

### Optional: Support tray tool kit.

#### For support of the lower run.

Simple one-piece support trays according to your requirements and specification.

The complete range with order options ► from page 714



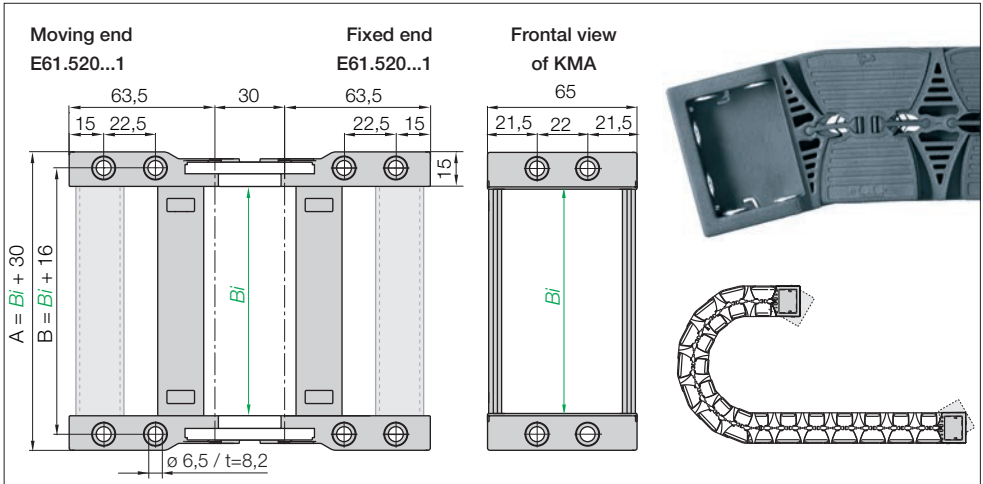

## KMA pivoting | Standard | Recommended for unsupported applications

Width Index	Part No. full set KMA pivoting: (optional with C-profile)	Dim A [mm]	Dim B [mm]	$Bi$ [mm]	Width Index	Part No. full set KMA pivoting: (optional with C-profile)	Dim A [mm]	Dim B [mm]	$Bi$ [mm]
040.	▶ E61.520.040.12.C	70	56	40	150.	▶ E61.520.150.12.C	180	166	150
050.	▶ E61.520.050.12.C	80	66	50	175.	▶ E61.520.175.12.C	205	191	175
052.	▶ E61.520.052.12.C	82	78	52	200.	▶ E61.520.200.12.C	230	216	200
062.	▶ E61.520.062.12.C	92,5	78,5	62,5	225.	▶ E61.520.225.12.C	255	241	225
070.	▶ E61.520.070.12.C	100	86	70	250.	▶ E61.520.250.12.C	280	266	250
075.	▶ E61.520.075.12.C	105	91	75	262.	▶ E61.520.262.12.C	292,5	278,5	262,5
087.	▶ E61.520.087.12.C	117,5	103,5	87,5	275.	▶ E61.520.275.12.C	305	291	275
100.	▶ E61.520.100.12.C	130	116	100	300.	▶ E61.520.300.12.C	330	316	300
125.	▶ E61.520.125.12.C	155	141	125					

(KMA = Polymer Metal Mounting Bracket)

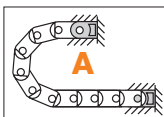

These attachment types are set automatically in the choice of the KMA mounting bracket.  
For the **preassembled** mode please add index **A**.

## E61.520.100.12.CA Part No. structure

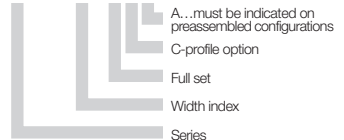

**Strain relief** e.g. clamps, tiewrap plates, nuggets and plug-in clips are available from stock. The complete chainfix range with order options ▶ from page 630



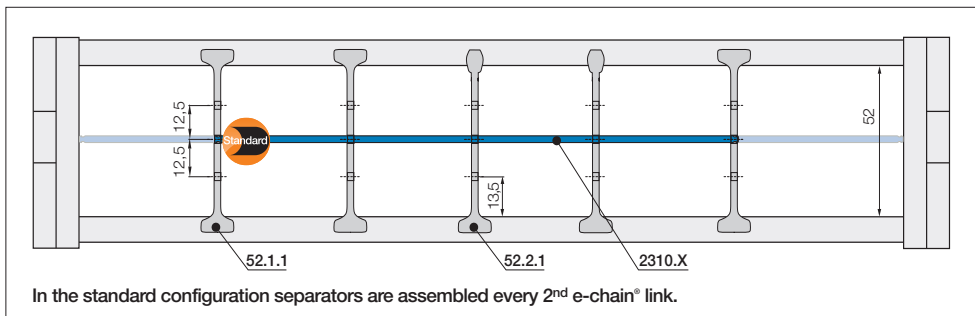

**Standard separator, wide base**

unassembled	<b>52.1</b>
assembled	<b>52.1.1</b>

### Standard - for all applications

Separator with a wide base for maximum locking strength and safe standing in e-chains®.

**Separator, narrow head**

unassembled	<b>52.2</b>
assembled	<b>52.2.1</b>

### For even faster installation

Firm hold to one side with a wide base, narrow on opposed side for easy cable assembly (slight grip).

**Full-width shelf, lockable**

unassembled	<b>2300.X</b>
assembled	<b>2310.X</b>

### Horizontal separation

Shelf locks safely into separators on both ends, fixed width though possible. Separators can be moved freely over the shelf in horizontal direction. Can be arranged at 3 different heights.



### Lockable full-width shelves - for the standard interior separation

Width X [mm]	unassembled	assembled	Width X [mm]	unassembled	assembled	Width X [mm]	unassembled	assembled
015	2300.015	2310.015	060	2300.060	2310.060	087	2300.087	2310.087
025	2300.025	2310.025	062	2300.062	2310.062	090	2300.090	2310.090
030	2300.030	2310.030	065	2300.065	2310.065	100	2300.100	2310.100
038	2300.038	2310.038	070	2300.070	2310.070	103	2300.103	2310.103
040	2300.040	2310.040	075	2300.075	2310.075	110	2300.110	2310.110
050	2300.050	2310.050	077	2300.077	2310.077	120	2300.120	2310.120
057	2300.057	2310.057	080	2300.080	2310.080	125	2300.125	2310.125

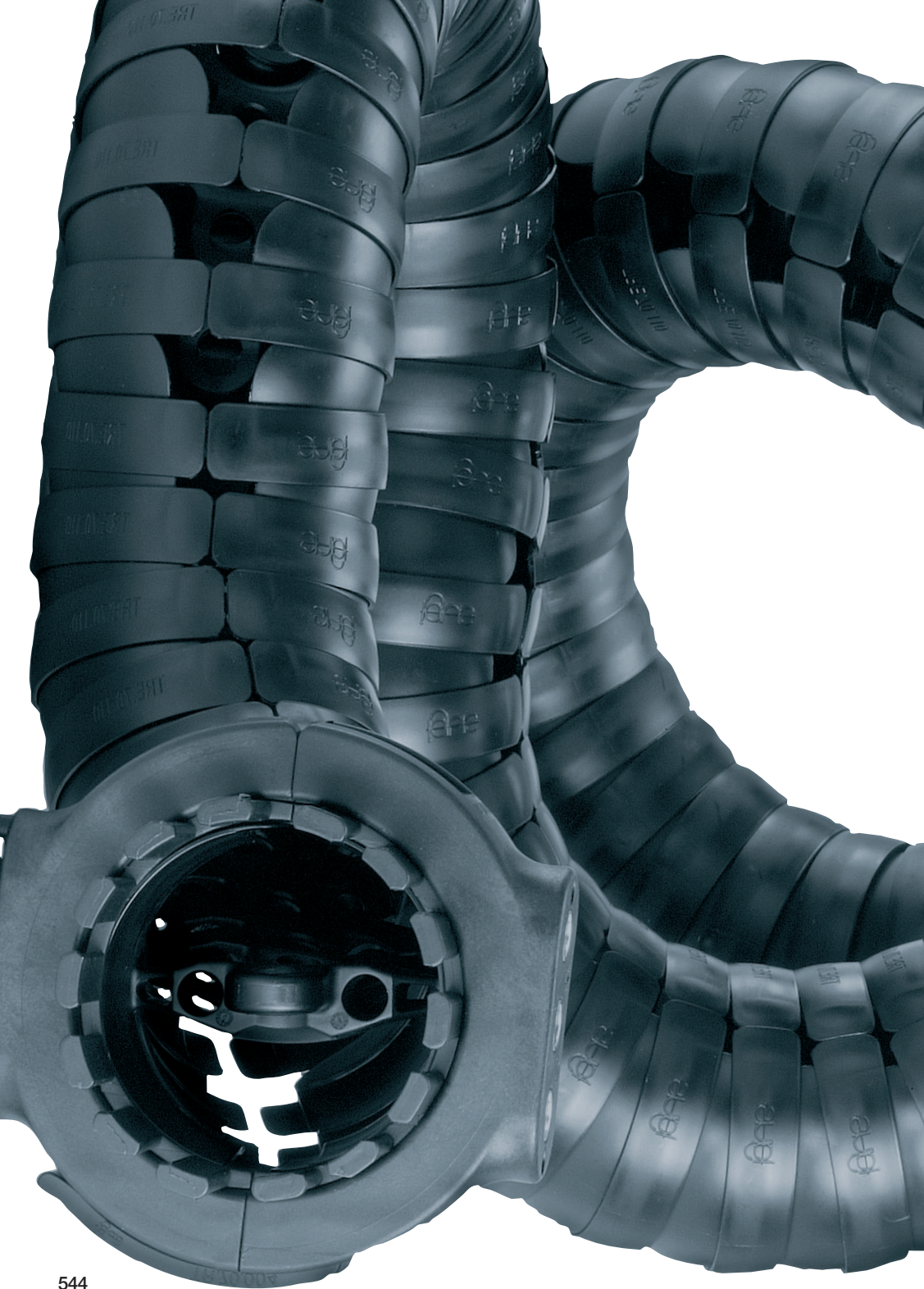



# igus<sup>®</sup> 3D e-chains<sup>®</sup>

robotic and  
circular movements

# 3D for robotic applications, closed and chip-resistant

TRC - closed, chip-resistant design

High tensile strength thanks to special ball-and-socket principle

Able to move multi-dimensionally - Twist up to approx.  $\pm 10^\circ$  per link possible in longitudinal axis

Impact-resistant, dirt-repelling, rugged and abrasion-resistant

Easy assembly and dismantling - injection-molded component

High stability - thanks to exterior stop dogs

Small bending radii and short pitch

Easy attachment and intelligent accessories onto the robot/machine

triflex® R (R for "round") is the third generation of multi-axis e-chains®.

- Secure, closed and chip-resistant energy supply for multi-dimensional (3D) movements
- Smooth and robust exterior against interfering edges
- Approximately  $\pm 10^\circ$  twist per e-chain® link
- High tensile strength of the ball-and-socket joint
- High torsional stability
- Easy to shorten and lengthen

## Typical industries and applications

- Robotics/Automation
- Machine tools
- Handling machines - 6-axis
- Packaging machines
- General mechanical engineering, etc.



Series TRC - Electrically conductive ESD/ATEX version upon request



Cleanroom suitability upon request



iF produkt design award  
2004 igus® Series TRC



# triflex® R | Series TRC | Selection Table

Series	Inner height		max. cable ø		Outer width <i>Ba</i> [mm]	Bending radii <i>R</i> [mm]	Pitch [mm]	Links per m	Page
	<i>Bi 1</i>	<i>Bi 2</i>	<i>d1</i>	<i>d2</i>					

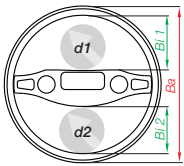

**Series "TRC" - closed design**  
dirt-resistant,  
smooth and robust exterior

TRC.30	12	10	10	8	34,5	50	11,3	89	548
TRC.40	15	13	13	11	43	58	13,9	72	548
TRC.60	22,5	19,5	20,5	17,5	65	87	20,4	49	548
TRC.70	28	24	26	22	81	110	25,6	39	548
TRC.85	33	28	31	26	94,5	135	30,6	33	548
TRC.100	37,5	32,5	35,5	30,5	108	145	34,5	29	548
TRC.125 <sup>2)</sup>	43,3	43,3	41	41	135	182	44,6	23	548

2) TRC.125 - max. cable diameter Ø 41 mm. Max. cable diameter changes to Ø 36 mm only, if shortening/lengthening of a filled triflex® R is required

## Technical Data

 Speed / acceleration	upon request
 Material - permitted temperature °C, igumid NB	-40° up to +80°C
 Flammability class, igumid NB	VDE 0304 IIC UL94-V2



## Order example | Order key and color options

 Order example for complete e-chain® (1,0 m), color black, with mounting brackets and intermediate links:

e-chain® (1,0 m)	Please indicate e-chain® length or number of links: 1,0 m or 72 links	TRC.40.058.0
+ Mounting brackets	1 mounting bracket with strain relief	TR.40.01
+ 2 Intermediate links		TR.40.02

Order text: 1,0 m TRC.40.058.0 + TR.40.01 + TR.40.02

 Order key **TRC.40.058.0**

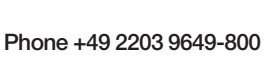
Series / Closed design	
Width index Ø	
Bending radius <i>R</i>	
Standard color black	

TRC - Closed design, dirt-resistant, with *Bi 15/13* mm inner width and *R 058* mm radius, color black = Part No. **TRC.40.058.0**

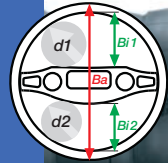

...TRC  
Closed design



## triflex® R | Series TRC | Closed design, dirt-resistant

Standard Series TRC "closed"	Bi 1 [mm]	Bi 2 [mm]	Ba [mm]	R [mm]	d1 [mm]	d2 [mm]	Pitch [mm]	Links/m	Weight [kg/m]
TRC.30. 050.0	12	10	34,5	050	10	8	11,3	89	≈ 0,27
TRC.40. 058.0	15	13	43	058	13	11	13,9	72	≈ 0,37
TRC.60. 087.0	22,5	19,5	65	087	20,5	17,5	20,4	49	≈ 0,85
TRC.70. 110.0	28	24	81	110	26	22	25,6	39	≈ 1,32
TRC.85. 135.0	33	28	94,5	135	31	26	30,6	33	≈ 1,75
TRC.100.145.0	37,5	32,5	108	145	35,5	30,5	34,5	29	≈ 2,38
TRC.125.182.0 <sup>3)</sup>	43,3	43,3	135	182	41	41 <sup>2)</sup>	44,6	23	≈ 4,70

2) Max. cable diameter Ø 41 mm. Max. cable diameter changes to Ø 36 mm only, if shortening/lengthening of a filled triflex® R is required

3) TRC.125: C-version is standard!

## Dimensions

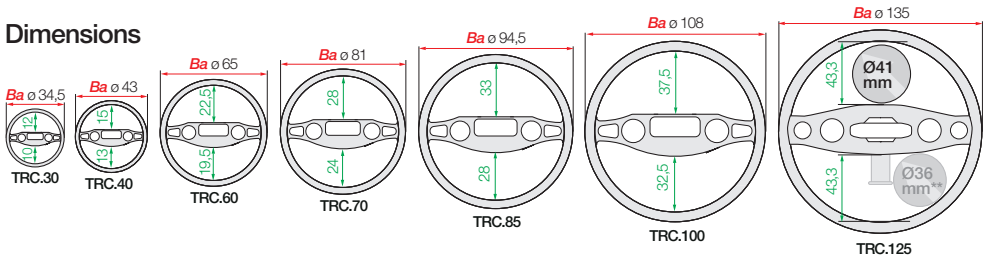

## Simply configure interior separation for igus® triflex® R e-chains®

- Quick and easy inner configuration for triflex® R systems
- Takes the max. filling cross section and cable diameter into account
- Creating list of parts ● Simple inquiry and order function.

Interior separation configurator ► [www.igus.eu/eu/quickchain100](http://www.igus.eu/eu/quickchain100)



# triflex® R | Series TRC | Accessories

## Standard mounting bracket

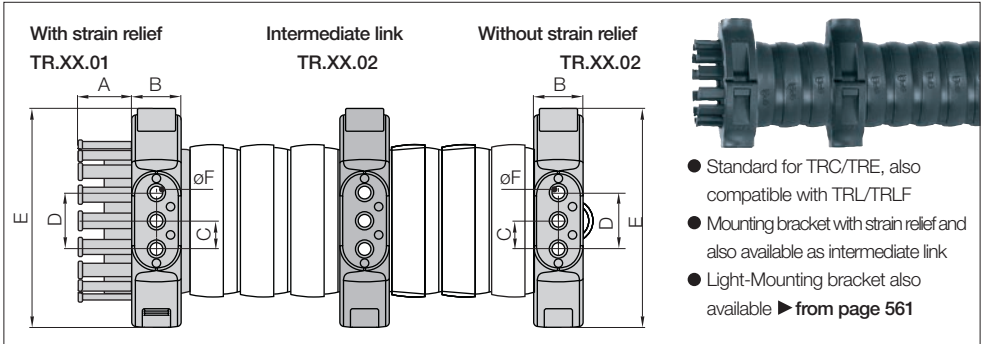

### Standard | Quick and easy fixing onto the robot/machine

(Light-mounting brackets ▶ from page 561)

Width Index	Part No. with strain relief	Part No. as intermediate link	Dim. A [mm]	Dim. B [mm]	Dim. C [mm]	Dim. D [mm]	Dim. E [mm]	Dim. F [mm]
30. ▶	Please use table for TL.30.01.XX		-	-	-	-	-	-
40. ▶	TR.40.01. M6	TR.40.02. M6	17,8	21	13,5	27	85	6,5
60. ▶	TR.60.01. M8	TR.60.02. M8	25	35	20	40	126	9
70. ▶	TR.70.01. M8	TR.70.02. M8	25	35	20	40	126	9
85. ▶	TR.85.01. M8	TR.85.02. M8	40	35	20	40	153	9
100. ▶	TR.100.01.M8	TR.100.02.M8	38	35	20	40	153	9
125. ▶	-	TR.125.02.M8	TR.125.XX - Dimensions please see drawing above					

Strain relief is possible on the moving end and/or the fixed end.  
**Standard:** Trough holes in  $\varnothing F$  - **Option:** with insert nuts, steel, M6/M8

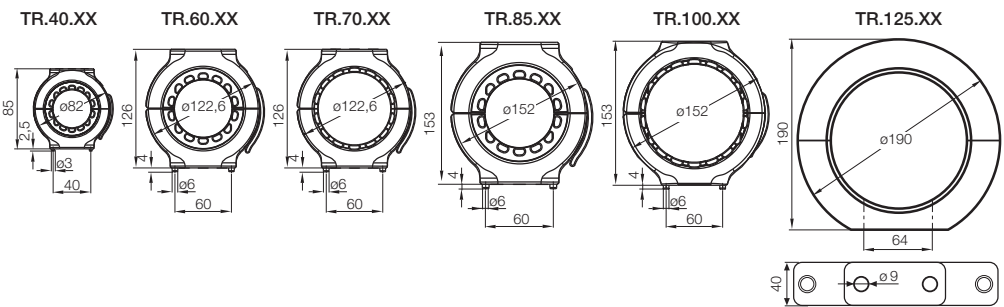

### All triflex® R accessories like:

- Swivel bearings for smooth motion
  - Protectors
  - Gliding feed-throughs
  - Strain relief systems: Quick exchange kit, Pivot bracket, triflex® R connection
  - TRE.LOCK clips
  - Back pull systems: RS triflex® R-Set the universal module and RSP the intelligent retraction system
  - Fiber rod module & Installation kit
  - Protective jackets.
- More information ▶ from page 562

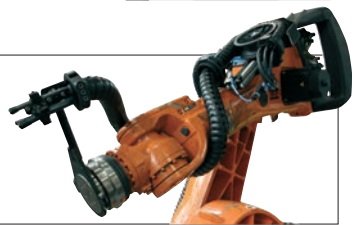

TRE - "easy"-design-  
simply press cables in

High tensile strength thanks to  
special ball-and-socket principle

Able to move multi-dimensionally -  
Twist up to approx.  $\pm 10^\circ$  per link  
possible in longitudinal axis

Easy opening mechanism for easy  
filling with cable and hose packages

Easy assembly and dismantling -  
injection-molded component

High stability - thanks  
to exterior stop dogs

Small bending radii and short pitch

Easy attachment  
and intelligent accessories  
onto the robot/machine

## 3D for robotic applications, simply press cables in

triflex® R (R for "round") is the third generation of multi-axis e-chains®.

- Easy to fill energy supply for multi-dimensional (3D) movements
- Easy opening mechanism for easy filling with cable and hose packages
- Approximately  $\pm 10^\circ$  twist per e-chain® link
- High tensile strength of the ball-and-socket joint
- High torsional stability
- Easy to shorten and lengthen

### Typical industries and applications

- Robotics/Automation
- Machine tools
- Handling machines - 6-axis
- Packaging machines
- General mechanical engineering, etc.



Cleanroom suitability  
upon request





# triflex® R | Series TRE | Selection Table

Series	Inner height		max. cable ø		Outer width	Bending radii	Pitch	Links per m	Page
	<i>Bi 1</i>	<i>Bi 2</i>	<i>d1</i>	<i>d2</i>	<i>Ba</i> [mm]	<i>R</i> [mm]	[mm]		

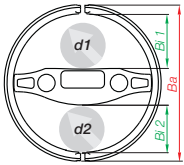

**Series "TRE" - "easy"-design**  
Fast installation of cables and hoses, simply press cables in

TRE.30	12	10	10 <sup>1)</sup>	8 <sup>1)</sup>	34,5	50	11,3	89	552
TRE.40	15	13	13 <sup>1)</sup>	11 <sup>1)</sup>	43	58	13,9	72	552
TRE.60	22,5	19,5	20,5 <sup>1)</sup>	17,5 <sup>1)</sup>	65	87	20,4	49	552
TRE.70	28	24	26 <sup>1)</sup>	22 <sup>1)</sup>	81	110	25,6	39	552
TRE.85	33	28	31 <sup>1)</sup>	26 <sup>1)</sup>	94,5	135	30,6	33	552
TRE.100	37,5	32,5	35,5 <sup>1)</sup>	30,5 <sup>1)</sup>	108	145	34,5	29	552
TRE.125 <sup>2)</sup>	43,3	43,3	41 <sup>1)</sup>	41 <sup>1)</sup>	135	182	44,6	23	552

1) For quick and easy insertion / removal of cables using the easy chain® principle, we recommend a maximum cable diameter of 70% of the specified value.

2) TRE.125 - max. cable diameter Ø 41 mm. Max. cable diameter changes to Ø 36 mm only, if shortening/lengthening of a filled triflex® R is required

## Technical Data

 Speed / acceleration	upon request
 Material - permitted temperature °C, igumid NB	-40° up to +80°C
 Flammability class, igumid NB	VDE 0304 IIC UL94-V2

## Order example | Order key and color options

 Order example for complete e-chain® (1,0 m), color black, with mounting brackets and intermediate links:

e-chain® (1,0 m)	Please indicate e-chain® length or number of links: 1,0 m or 72 links	TRE.40.058.0
+ Mounting brackets	1 mounting bracket with strain relief	TR.40.01
+ 1 Intermediate link		TR.40.02

Order text: 1,0 m TRE.40.058.0 + TR.40.01 + TR.40.02

 Order key **TRE.40.058.0.B**

- Series / "easy"-design
- Width index Ø
- Bending radius *R*
- Standard color black
- Optional B-/C-version



TRE - Series "TRE" - "easy"-design  
with *Bi 15/13* mm inner width and *R 058* mm radius,  
color black = Part No. **TRE.40.058.0**

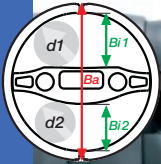

...TRE  
simply press cables in



## triflex® R | Series TRE | "easy"-design, simply press cables in

Series TRE "easy"-Design	Standard	Series TRE B-Version	Series TRE C-Version	Bi 1 [mm]	Bi 2 [mm]	Ba [mm]	R [mm]	d1 <sup>1)</sup> [mm]	d2 <sup>1)</sup> [mm]	Pitch [mm]	Links/m	Weight [kg/m]
TRE.30.050.0	–	–	–	12	10	34,5	050	10	8	11,3	89	≈ 0,26
TRE.40.058.0	TRE.40.058.0.B	–	–	15	13	43	058	13	11	13,9	72	≈ 0,36
TRE.60.087.0	TRE.60.087.0.B	–	–	22,5	19,5	65	087	20,5	17,5	20,4	49	≈ 0,83
TRE.70.110.0	TRE.70.110.0.B	–	–	28	24	81	110	26	22	25,6	39	≈ 1,30
TRE.85.135.0	TRE.85.135.0.B	–	–	33	28	94,5	135	31	26	30,6	33	≈ 1,67
TRE.100.145.0	TRE.100.145.0.B	TRE.100.145.0.C	–	37,5	32,5	108	145	35,5	30,5	34,5	29	≈ 2,35
TRE.125.182.0	–	X <sup>3)</sup>	–	43,3	43,3	135	182	41	41 <sup>2)</sup>	44,6	23	≈ 4,40

1) For quick and easy insertion / removal of cables using the easy chain® principle, we recommend a maximum cable diameter of 70% of the specified value.

2) Max. cable diameter Ø 41 mm. Max. cable diameter changes to Ø 36 mm only, if shortening/lengthening of a filled triflex® R is required

3) TRE.125: C-version is standard!

## Dimensions

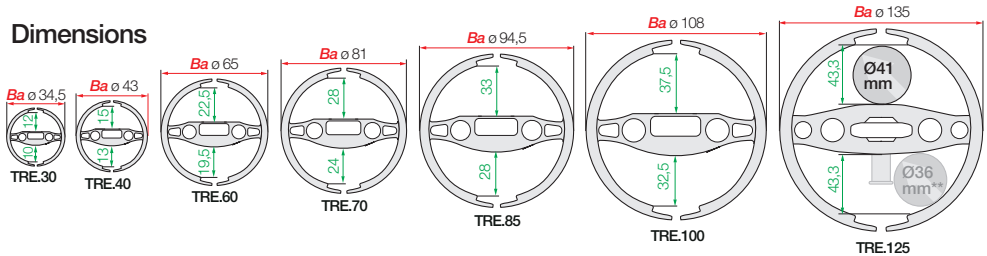

## B-version | 4 x higher torsion forces



The advanced ball and socket connection now uses an additional arrester for even higher stability. Especially designed for heavy duty applications and all back pull systems (RS and RSP) with high accelerations and top speeds.

● Up to 4 times stronger with improved bending radius strength ● Able to handle even higher torsion forces ●

Made of only one single part per e-chain® link ► [www.igus.eu/eu/triflexR-Bversion](http://www.igus.eu/eu/triflexR-Bversion)

## C-version | Quick assembly, 50% higher forces



Now available with proven bolt connection for even faster assembly and disassembly ● Linear pull force capacity increased up to 4.000 N ● Up to 4 times stronger and improved bending radius strength ● C-version drastically reduces installation time ● Stronger lock for torsion limitation ● igubal® Spherical Bearing for non-slip traction ► [www.igus.eu/eu/triflexR-Cversion](http://www.igus.eu/eu/triflexR-Cversion)

# triflex® R | Series TRE | Accessories

## Standard mounting bracket

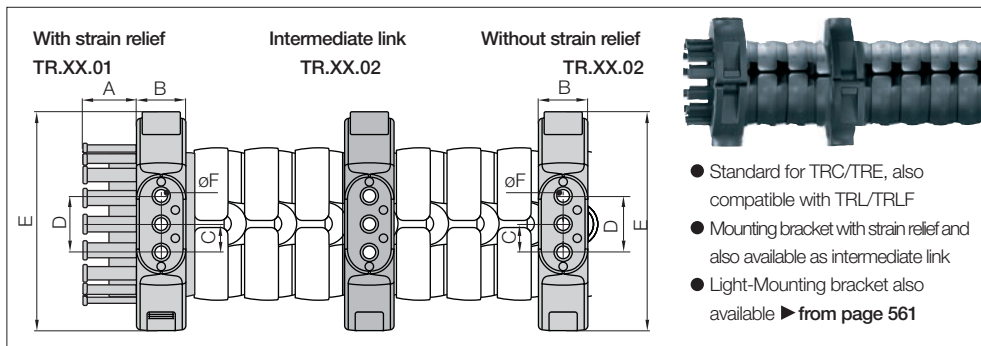

### Standard | Quick and easy fixing onto the robot/machine

(Light-mounting brackets ▶ from page 561)

Width Index	Part No. with strain relief	Part No. as intermediate link	Dim. A [mm]	Dim. B [mm]	Dim. C [mm]	Dim. D [mm]	Dim. E [mm]	Dim. F Ø [mm]
30. ▶	Please use table for TL.30.01.XX		-	-	-	-	-	-
40. ▶	TR.40.01. M6	TR.40.02. M6	17,8	21	13,5	27	85	6,5
60. ▶	TR.60.01. M8	TR.60.02. M8	25	35	20	40	126	9
70. ▶	TR.70.01. M8	TR.70.02. M8	25	35	20	40	126	9
85. ▶	TR.85.01. M8	TR.85.02. M8	40	35	20	40	153	9
100. ▶	TR.100.01.M8	TR.100.02.M8	38	35	20	40	153	9
125. ▶	-	TR.125.02.M8	TR.125.XX - Dimensions please see drawing above					

Strain relief is possible on the moving end and/or the fixed end.

Standard: Trough holes in Ø F - Option: with insert nuts, steel, M6/M8

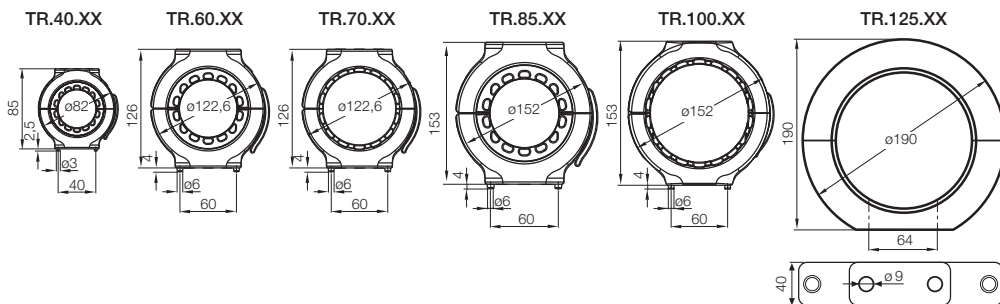

### All triflex® R accessories like:

- Swivel bearings for smooth motion
  - Protectors
  - Gliding feed-throughs
  - Strain relief systems: Quick exchange kit, Pivot bracket, triflex® R connection
  - TRE.LOCK clips
  - Back pull systems: RS triflex® R-Set the universal module and RSP the intelligent retraction system
  - Fiber rod module & Installation kit
  - Protective jackets.
- More information ▶ from page 562



TRL - light and low-cost  
with "easy"-design

High tensile strength thanks to  
special ball-and-socket principle

Able to move multi-dimensionally -  
Twist up to approx.  $\pm 10^\circ$  per link  
possible in longitudinal axis

Easy opening mechanism for easy  
filling with cable and hose packages

Easy assembly and dismantling -  
injection-molded component

Extremely light due  
to one-piece design

Small bending radii and short pitch

Economical and light  
mounting bracket with strain  
relief or intermediate link

## 3D for robotic applications, light and economical

triflex® R (R for "round") is the third  
generation of multi-axis e-chains®.

- Easy to fill, economical 3D e-chain®
- 3D e-chain® for easily manageable operating conditions
- Approximately  $\pm 10^\circ$  twist per e-chain® link
- High tensile strength of the ball-and-socket joint
- Easy to shorten and lengthen

### Typical industries and applications

- Robotics/Automation
- Machine tools
- Handling machines - 6-axis
- Packaging machines
- General mechanical engineering, etc.



Cleanroom suitability  
upon request



iF produkt design award  
2007 igus® Series TRL

product  
design  
award

2007



# triflex® R | Series TRL | Selection Table

Series	Inner height		max. cable ø		Outer width	Bending radii	Pitch	Links per m	Page
	<i>Bi 1</i>	<i>Bi 2</i>	<i>d1</i>	<i>d2</i>	<i>Ba</i> [mm]	<i>R</i> [mm]	[mm]		

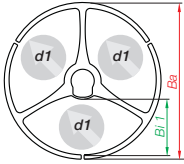

**Series "TRL" - 3-chamber system**  
The "light" variant of the "easy"-design simply press cables in

TRL.30*	12,5	11	10 <sup>1)</sup>	8 <sup>1)</sup>	34,5	50	11,3	89	556
TRL.40	15	-	13 <sup>1)</sup>	-	45	58	13,9	72	556
TRL.60	23	-	20,5 <sup>1)</sup>	-	65	87	20,4	49	556
TRL.70	28	-	26 <sup>1)</sup>	-	81	110	25,6	39	556
TRL.100	38	-	35,5 <sup>1)</sup>	-	108	145	34,5	29	556

1) For quick and easy insertion / removal of cables using the easy chain® principle, we recommend a maximum cable diameter of 70% of the specified value.

\* only with 2-chamber system

## Technical Data

	Speed / acceleration	upon request
	Material - permitted temperature °C, igumid NB	-40° up to +80°C
	Flammability class, igumid NB	VDE 0304 IIC UL94-V2

## Order example | Order key and color options

Order example for complete e-chain® (1,0 m), color black, with mounting brackets:

e-chain® (1,0 m) Please indicate e-chain® length or number of links: 1,0 m or 72 links **TRL.40.058.0**

+ Light-mounting brackets 1 mounting bracket with strain relief **TL.40.01.Z1**

Order text: 1,0 m TRL.40.058.0 + TL.40.01.Z1

Order key **TRL.40.058.0**

Series / "easy"-design

Width index Ø

Bending radius *R*

Standard color black



TRL- The "light" variant of the "easy"-design with *Bi 15* mm inner width and *R 058* mm radius, color black = Part No. **TRL.40.058.0**

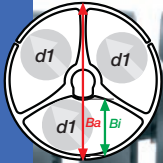

...TRL  
Light with "easy"-design

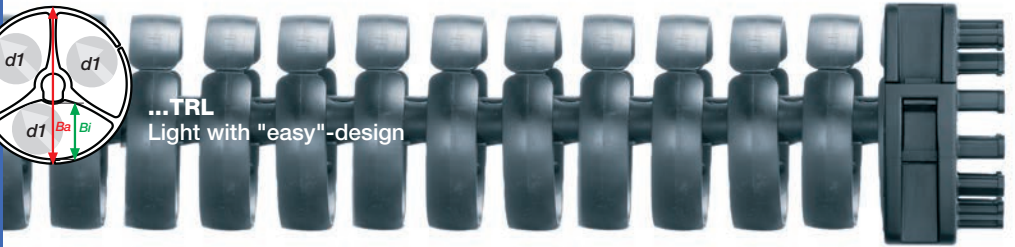

## triflex® R | Series TRL | Light alternative with "easy"-design

Series TRL "light"	Bi 1 [mm]	Bi 2 [mm]	Ba [mm]	R mm	d1 <sup>1)</sup> mm	d2 <sup>1)</sup> mm	Pitch [mm]	Links/m	Weight [kg/m]
TRL.30.050.0 <sup>2)</sup>	12,5	11	34,5	050	10	8	11,3	89	≈ 0,15
TRL.40.058.0	15	–	45	058	13	–	13,9	72	≈ 0,20
TRL.60.087.0	23	–	65	087	20,5	–	20,4	49	≈ 0,40
TRL.70.110.0	28	–	81	110	26	–	25,6	39	≈ 0,70
TRL.100.145.0	38	–	108	145	35,5	–	34,5	29	≈ 1,20

1) For quick and easy insertion / removal of cables using the easy chain® principle, we recommend a maximum cable diameter of 70% of the specified value.

2) only with 2-chamber system

## Dimensions

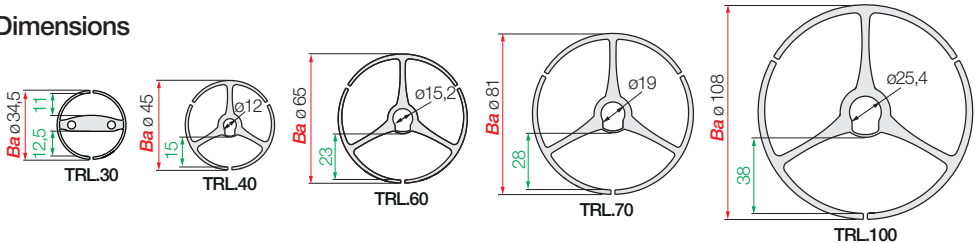

### Simply configure interior separation for igus® triflex® R e-chains®

- Quick and easy inner configuration for triflex® R systems
- Takes the max. filling cross section and cable diameter into account
- Creating list of parts ● Simple inquiry and order function.

Interior separation configurator ► [www.igus.eu/eu/quickchain100](http://www.igus.eu/eu/quickchain100)



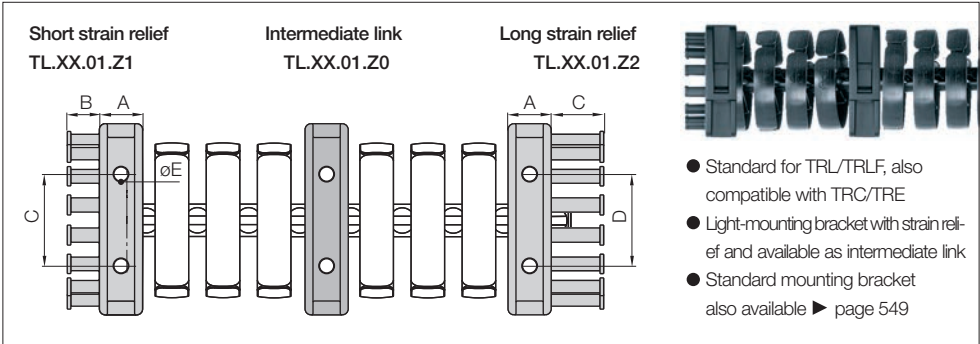

### Light | Quick and easy fixing onto the robot/machine

(Standard-mounting brackets ► from page 549)

Width Index	Part No. with short strain relief	Part No. with long strain relief	Part No. Intermediate link	Dim. A [mm]	Dim. B [mm]	Dim. C [mm]	Dim. D [mm]	Dim. E [mm]
30. ►	TL.30.01 .Z1	–	TL.30.01 .Z0	13	12,5	–	24	4,5
40. ►	TL.40.01 .Z1*	TL.40.01 .Z2	TL.40.01 .Z0	14	12,5	20	36	5,8
60. ►	TL.60.01 .Z1*	TL.60.01 .Z2	TL.60.01 .Z0	20	17	27	48	5,8
70. ►	TL.70.01 .Z1*	TL.70.01 .Z2	TL.70.01 .Z0	27	17,5	27,5	64	6,5
100. ►	TL.100.01.Z1*	TL.100.01.Z2	TL.100.01.Z0	30	22,5	42,5	64	6,5

\*For moving end (ball) suitable only Series TRL/TRLF

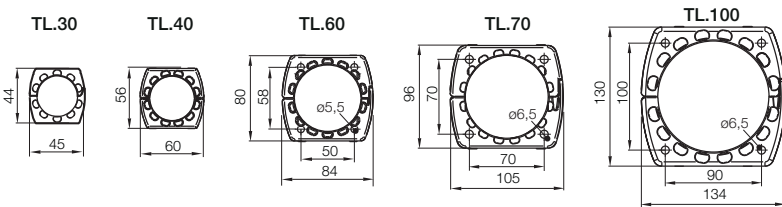

### All triflex® R accessories like:

- Swivel bearings for smooth motion
  - Protectors
  - Gliding feed-throughs
  - Strain relief systems: Quick exchange kit, Pivot bracket, triflex® R connection
  - TRE.LOCK clips
  - Back pull systems: RS triflex® R-Set the universal module and RSP the intelligent retraction system
  - Fiber rod module & Installation kit
  - Protective jackets.
- More information ► from page 562

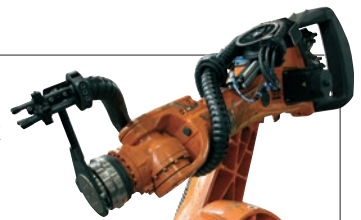

New in this catalog

TRLF - light and low-cost  
with snap lock mechanism

High tensile strength thanks to  
special ball-and-socket principle

Able to move multi-dimensionally -  
Twist up to approx.  $\pm 10^\circ$  per link  
possible in longitudinal axis

Simply flip open for large, stiff  
hoses and/or many cables

Easy assembly and dismantling

Extremely light due to one-piece design

3-chamber principle  
for interior separation

Small bending radii and short pitch

Economical and light  
mounting bracket with strain  
relief or intermediate link

# Light-variant with snap lock mechanism. Openable by hand or with screwdriver

- Simply flip open manually or with screw driver for large, stiff hoses and/or many cables
- 3D e-chain® for easily manageable operating conditions
- Approximately  $\pm 10^\circ$  twist per e-chain® link
- High tensile strength of the ball-and-socket joint
- Light and cost effective
- Easy to shorten and lengthen

## Typical industries and applications

- Light robot applications
- 3D motions
- Cable supply systems in furniture construction
- Robot applications - Axis 2+3

Snap lock mechanism to  
open by hand or screwdriver



video online ►

[www.igus.eu/eu/TRLF](http://www.igus.eu/eu/TRLF)



iF product design award

2013 igus® Series TRLF

2013



3D-CAD files, configurators, PDF ► [www.igus.eu/eu/TRLF](http://www.igus.eu/eu/TRLF)



# triflex® R | Series TRLF | Selection Table

Series	Inner height <i>Bi</i>	max. cable ø <i>d1</i>	Outer width <i>Ba</i> [mm]	Bending radii <i>R</i> [mm]	Pitch [mm]	Links per m	Page
--------	---------------------------	---------------------------	-------------------------------	--------------------------------	---------------	----------------	------

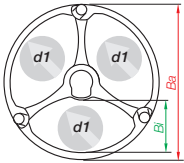

**Series "TRLF" -  
Light-variant with snap  
lock mechanism**  
light and low-cost

TRLF.65	New*	24,4	22	70,2	100	23,1	44	560
TRLF.85	New*	32,8	30	94,5	135	31	33	560
TRLF.100	New*	37,5	35,5	108	145	35,4	29	560

\* in this catalog

## Technical Data

	Speed / acceleration	upon request
	Material - permitted temperature °C, igumid G	-40° up to +120°C
	Flammability class, igumid G	VDE 0304 IIC UL94-HB

## Order example | Order key and color options

Order example for complete e-chain® (1,0 m),  
color black, with mounting brackets:

e-chain® (1,0 m) Please indicate e-chain® length or number of links: 1,0 m or 29 links **TRLF.100.145.0**

+ Light-mounting brackets 1 mounting bracket with strain relief **TL.100.01.Z1**

Order text: 1,0 m TRLF.100.145.0 + TL.100.01.Z1

Order key **TRLF.100.145.0**

"Light-variant with  
snap lock mechanism

Width index Ø

Bending radius *R*

Standard color black



TRLF - Light-variant with snap lock mechanism  
with *Bi* 37,5 mm inner width and *R* 145 mm radius,  
color black = Part No. **TRLF.100.145.0**



Robotic applications, faster filling of even larger hoses and cables:

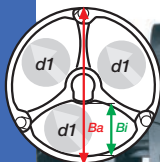

...TRLF  
Light with snap lock mechanism



triflex® R | Series TRLF | Light-variant with snap lock mechanism

Series TRLF light with snap lock	Bi [mm]	Ba [mm]	R mm	d1 mm	Pitch [mm]	Links/m	Weight [kg/m]
TRLF. 65. 100.0	24,4	70,2	100	22	23,1	44	≈ 0,79
TRLF. 85. 135.0	32,8	94,5	135	30	31	33	≈ 1,45
TRLF. 100.145.0	37,5	108	145	35,5	34,5	29	≈ 1,90

### Dimensions

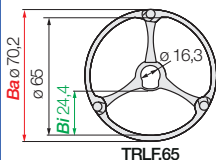

TRLF.65

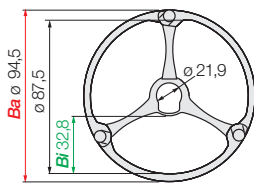

TRLF.85

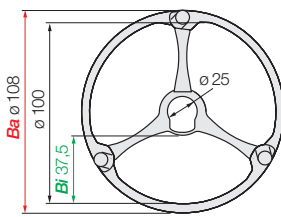

TRLF.100



### Simply configure interior separation for igus® triflex® R e-chains®

- Quick and easy inner configuration for triflex® R systems
- Takes the max. filling cross section and cable diameter into account
- Creating list of parts ● Simple inquiry and order function.

Interior separation configurator ► [www.igus.eu/eu/quickchain100](http://www.igus.eu/eu/quickchain100)

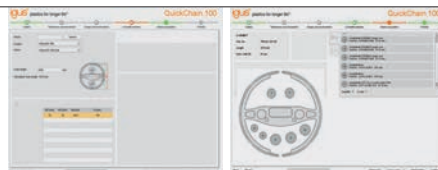

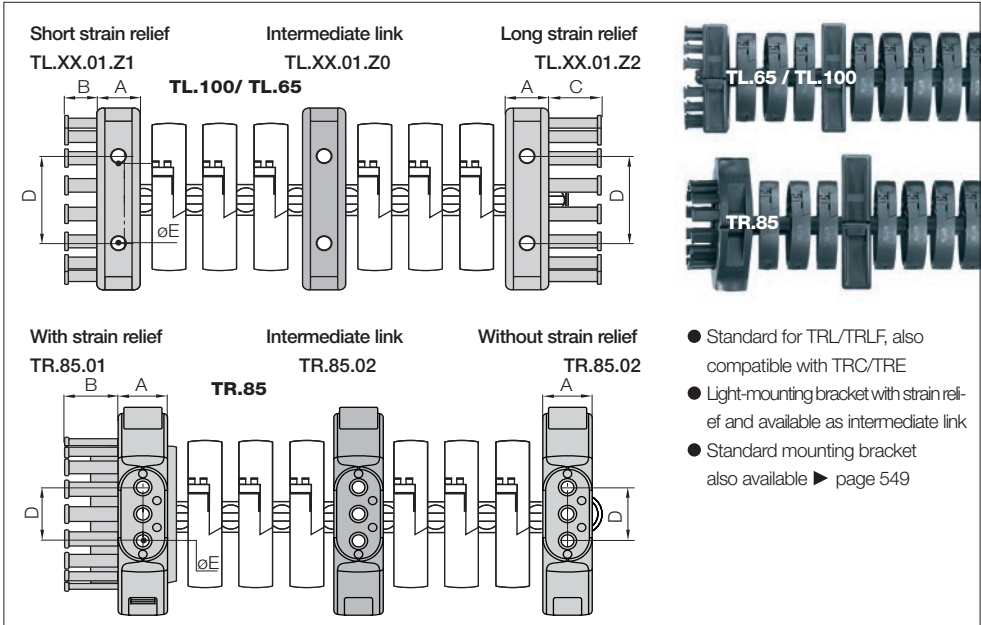

### Light | Quick and easy fixing onto the robot/machine

(Standard-mounting brackets ▶ from page 549)

Width Index	Part No. with short strain relief	Part No. with long strain relief	Part No. Intermediate link	Dim. A [mm]	Dim. B [mm]	Dim. C [mm]	Dim. D [mm]	Dim. E [mm]
					<b>Z1</b>	<b>Z2</b>		ø [mm]
65 ▶	TL.65.01.Z1**	–	TL.65.01.Z0	27	13,5	–	64	6,5
85. ▶	TR.85.01.M8*	–	TR.85.02.M8*	35	40	–	40	9
100. ▶	TL.100.01.Z1**	TL.100.01.Z2	TL.100.01.Z0	30	22,5	42,5	64	6,5

\*\*For moving end (ball) suitable only Series TRL/TRLF \*Option: with insert nuts, steel, M6/M8

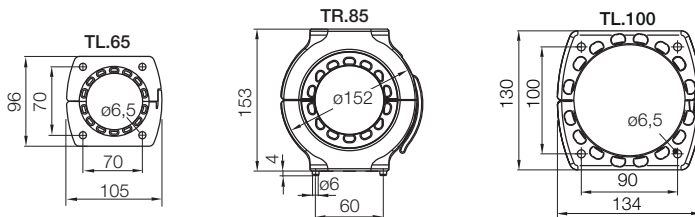

### All triflex® R accessories like:

- Swivel bearings for smooth motion
  - Protectors
  - Gliding feed-throughs
  - Strain relief systems: Quick exchange kit, Pivot bracket, triflex® R connection
  - TRE.LOCK clips
  - Back pull systems: RS triflex® R-Set the universal module and RSP the intelligent retraction system
  - Fiber rod module & Installation kit
  - Protective jackets.
- More information ▶ from page 562

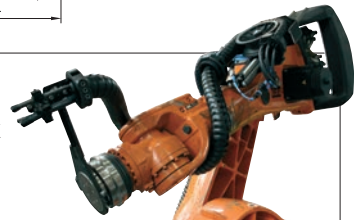

# triflex® R | Series TRC/TRE/TRL/TRLF | Accessories

## Swivel bearing, for smooth motion | Protectors

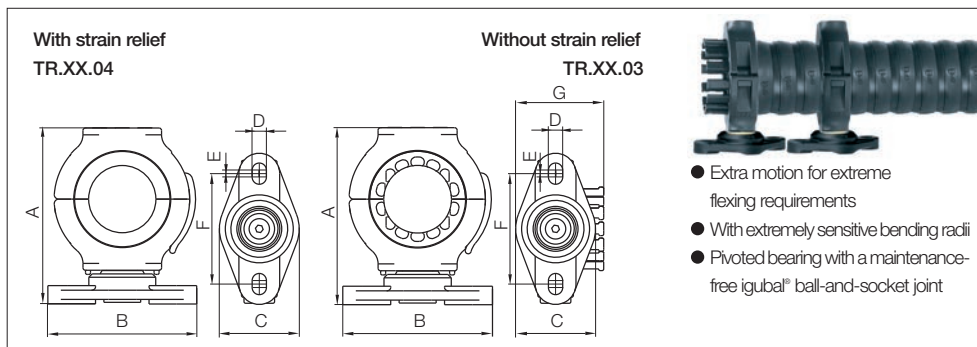

- Extra motion for extreme flexing requirements
- With extremely sensitive bending radii
- Pivoted bearing with a maintenance-free igubal® ball-and-socket joint

### Swivel bearing | Extra motion for extreme flexing requirements | for TRC/TRE/TRL/TRLF

Width index	Part No. with strain relief	Part No. intermediate link	Dim. A [mm]	Dim. B [mm]	Dim. C [mm]	Dim. D [mm]	Dim. E [mm]	Dim. F Ø [mm]	Dim. G* Ø [mm]
40.	▶ TR.40.03	TR.40.04	105	89	47	8,4	4,1	65	51,8
60.	▶ TR.60.03	TR.60.04	152	118	65	10,5	5,5	87,5	73,5
70.	▶ TR.70.03	TR.70.04	152	118	65	10,5	5,5	87,5	73,5
85.**	▶ TR.85.03	TR.85.04	179	118	65	10,5	5,5	87,5	88
100.	▶ TR.100.03	TR.100.04	179	118	65	10,5	5,5	87,5	88

\*only TR.XX.03

\*\*Width 85. not for Series TRL

### Protectors | High safety under extreme operating conditions | for TRC/TRE

- To achieve long life cycles under heavy loads resulting from impact or friction on the robot's e-chains®, optional protectors can be fitted at the contact points
- Easy assembly and quick replacement
- Abrasion-resistant TPU material
- Shock-resistant
- Light
- Easy gliding over edges
- Free positioning on any e-chain® link
- Protector with quick lock fastener available (Part No. TR.85.30 and TR.70.30)



Width index	Part No.	Part No. with quick lock	Ø D [mm]	A [mm]
40.	▶ TR.40.10	TR.40.30*	55	27
60.	▶ TR.60.10	TR.60.30*	80	40
70.	▶ TR.70.10	TR.70.30	102	50
85.	▶ TR.85.10	TR.85.30	118	59
100.	▶ TR.100.10	TR.100.30*	133	67
125.	▶ TR.125.10	TR.125.30*	170	82

\*Available upon request, please consult igus® for delivery time!

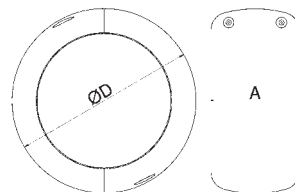

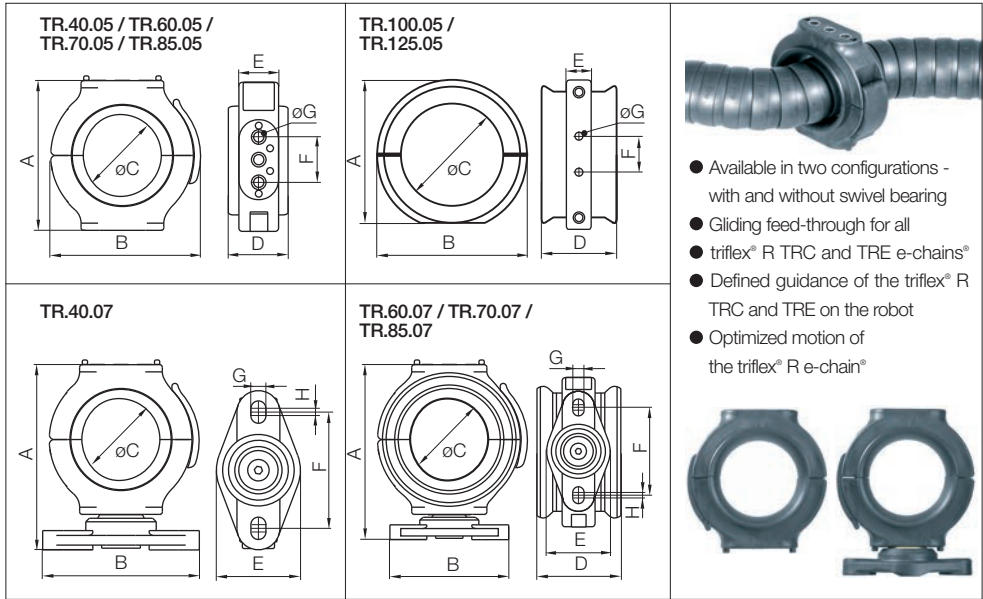

- Available in two configurations - with and without swivel bearing
- Gliding feed-through for all triflex® R TRC and TRE e-chains®
- Defined guidance of the triflex® R TRC and TRE on the robot
- Optimized motion of the triflex® R e-chain®

Gliding feed-throughs | Without swivel bearing | for TRC/TRE

Width index	Part No.	Dim. A [mm]	Dim. B [mm]	Dim. C Ø [mm]	Dim. D Ø [mm]	Dim. E Ø [mm]	Dim. F [mm]	Dim. G Ø [mm]
	<b>Gliding feed-throughs without swivel bearing</b>							
40.	▶ TR.40.05	85	84,5	46	32	21	27	6,5
60.	▶ TR.60.05	126	126	70	50	32	40	9
70.	▶ TR.70.05	153	155	86	70	35	40	9
85.	▶ TR.85.05	153	155	100	84	35	40	9
100.	▶ TR.100.05	162,5	169,5	115	85	28	40	8,5
125.	▶ TR.125.05	179	190	142	84	40	64	9

Gliding feed-throughs | With swivel bearing | for TRC/TRE

Width index	Part No.	Dim. A [mm]	Dim. B [mm]	Dim. C Ø [mm]	Dim. D [mm]	Dim. E [mm]	Dim. F Ø [mm]	Dim. G [mm]	Dim. H [mm]
	<b>Gliding feed-throughs with swivel bearing</b>								
40.	▶ TR.40.07	108	89	46	32	47	65	8,4	4,1
60.	▶ TR.60.07	156	118	70	50	65	87,5	10,5	5,5
70.	▶ TR.70.07	183	118	86	70	65	87,5	10,5	5,5
85.	▶ TR.85.07	183	118	100	84	65	87,5	10,5	5,5

### triflex® R TRE.LOCK clip | for TRE

- The TRE.XX.LOCK clip is used to ensure a secure fit for the mounting bracket on TRE versions
- TRE.XX.LOCK clips are automatically supplied with each mounting bracket - please use the following Part No. for reordering:

Width index	Part No. TRE.LOCK clips*
.30	TRE.30/40.LOCK
.40	TRE.30/40.LOCK
.60	TRE.60.LOCK
.70	TRE.70.LOCK
.85	TRE.70.LOCK
.100	TRE.100.LOCK
.125	TRE.125.LOCK

\*not for Series TRC/TRL/TRLF

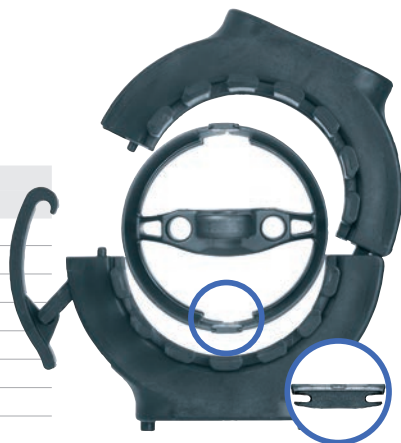

### Strain relief systems with igus® chainfix clamps | for TRC/TRE

- Secure mounting of large cross sections with igus® chainfix clamps
- Available in 3 options per size
- Multiaxially adjustable, for ideal positioning
- Suits all additional axles: Ø 30 mm, Ø 32 mm, Ø 34 mm

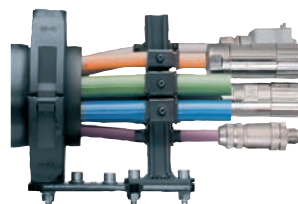

#### CFX - Single clamp housing, incl. bottom saddles

Part No. Steel	Part No. Stainless steel*	ø [mm]	B <sup>2</sup> [mm]	H [mm]	Part No. steel	Part No. Stainless steel*	ø [mm]	B <sup>2</sup> [mm]	H [mm]
CFX12.1	CFX12.1.E	06 - 12	16	54	CFX26.1	CFX26.1.E	22 - 26	30	67
CFX14.1	CFX14.1.E	12 - 14	18	50	CFX30.1	CFX30.1.E	26 - 30	34	71
CFX16.1	CFX16.1.E	14 - 16	20	52	CFX34.1	CFX34.1.E	30 - 34	38	75
CFX18.1	CFX18.1.E	16 - 18	22	54	CFX38.1	CFX38.1.E	34 - 38	42	79
CFX20.1	CFX20.1.E	18 - 20	24	56	CFX42.1	CFX42.1.E	38 - 42	46	83
CFX22.1	CFX22.1.E	20 - 22	26	58					

\*Material stainless steel: 1.4301/AISI 304

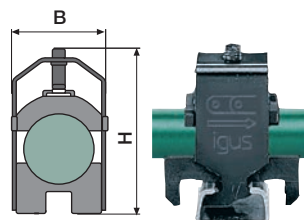

**Strain relief** e.g. clamps, tiewrap plates, nuggets and plug-in clips are available from stock. The complete chainfix range with order options ► from page 630

### chainflex® robotic cables: CFROBOT & CF77.UL.D PUR control cable

**CFROBOT:** ● Available from stock ● UL and CSA certified ● From 1 m, no minimum requirements ● ±180° on 1 m ● 3.000.000 cycles tested

**CF77.UL.D PUR control cable:** ● Available from stock ● ± 180° twistable ● For twistable load requirements. **More information** ► [www.igus.eu/eu/chainflexnews](http://www.igus.eu/eu/chainflexnews)

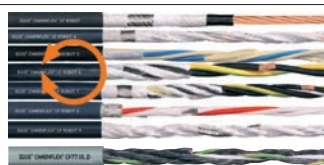

## triflex® R | Series TRC/TRE | Accessories

## Strain Relief

## Quick exchange kit TR.60/70/85/100.22.XX | for TRC/TRE

- Ideal for triflex® R readychain®
- One-time-only alignment
- No repeat alignment upon exchange of readychain®
- Exchange of th triflex® R unit incl. cables without any tools

Width index	Part No. <b>Quick exchange kit</b>
60.** ▶	TR.60 .22. <b>30 / 32 / 34*</b>
70.** ▶	TR.70 .22. <b>30 / 32 / 34*</b>
85.** ▶	TR.85 .22. <b>30 / 32 / 34*</b>
100.** ▶	TR.100.22. <b>30 / 32 / 34*</b>

\*\*not for Series TRL/TRLF

\*Please add the appropriate index Ø 30, 32, 34 mm.Example: TR.100.22.30



## Pivot bracket TR.60/70/85/100.21.XX | for TRC/TRE

- Available in 2 options per size (with/without strain relief)
- Safe and simple securing of the cables with cable ties
- Possible also without strain relief  
(Strain relief in the application)

Width index	Part No. Pivot bracket with strain relief	Part No. Pivot bracket without strain relief
60.** ▶	TR.60.21.01. <b>30 / 32 / 34*</b>	TR.60.21.02. <b>30 / 32 / 34*</b>
70.** ▶	TR.70.21.01. <b>30 / 32 / 34*</b>	TR.70.21.02. <b>30 / 32 / 34*</b>
85.** ▶	TR.85.21.01. <b>30 / 32 / 34*</b>	TR.85.21.02. <b>30 / 32 / 34*</b>
100.** ▶	TR.100.21.01. <b>30 / 32 / 34*</b>	TR.100.21.02. <b>30 / 32 / 34*</b>

\*\*not for Series TRL/TRLF

\*Please add the appropriate index Ø 30, 32, 34 mm.Example: TR.100.21.01.30



## Connection TR.60/70/85/100/125.20.XX | for TRC/TRE

- For cables with large cross section, e.g. welding applications or in heavy hydraulic hoses, rugged strain relief in "heavy-duty" applications
- Double C-profile for igus® CFX clips
- igus® chainfix clamps made of stainless steel or steel can be used (see Table left)

Width index	Part No. <b>triflex® R connection</b>
60.** ▶	TR.60 .20. <b>30 / 32 / 34*</b>
70.** ▶	TR.70 .20. <b>30 / 32 / 34*</b>
85.** ▶	TR.85 .20. <b>30 / 32 / 34*</b>
100.** ▶	TR.100.20. <b>30 / 32 / 34*</b>
125.** ▶	TR.125.20. <b>30 / 32 / 34*</b>

\*\*not for Series TRL/TRLF

\*Please add the appropriate index Ø 30, 32, 34 mm.Example: TR.100.20.30

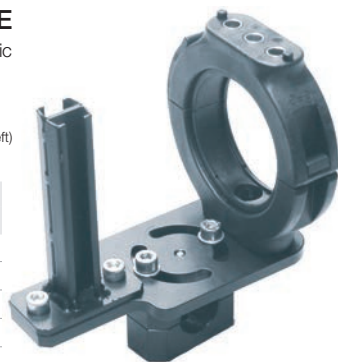

## Series TRC/TRE | Accessories

RS triflex® R-Set | Universal module | for TRC/TRE

Single module, space-saving and quickly mounted on robot

Integrated fiber rod prevents loop formation

Glide lead-through for a close and parallel guidance on the robotic arm

Limit stop dog for a defined free movement

Mounting brackets for safe fastening

### RS - Universal module for any robotic motion

triflex®RS is a very compact universal module that can be attached to the fastening points on the robot. Applications in very limited space can be realized, thanks to the small installation height and to the fact that triflex®RS can be installed parallel to the robotic arm. triflex®RS with integrated spring mechanism allows efficient energy supply to the robotic head, without stress on the cables.

- Standard-package for all applications for immediate installation
- Integrated spring mechanism
- The first choice for robotic applications with limited space
- Saves space - small installation height and closely routed on the robotic arm
- Outstanding service life
- Universal installation

RS with cover for the additional support of switch cabinets or valve terminals



Integrated retraction spring prevents loop formation





## Series TRC/TRE | Accessories | Dimensions

## RS triflex® R-Set | Universal module | for TRC/TRE

## Right

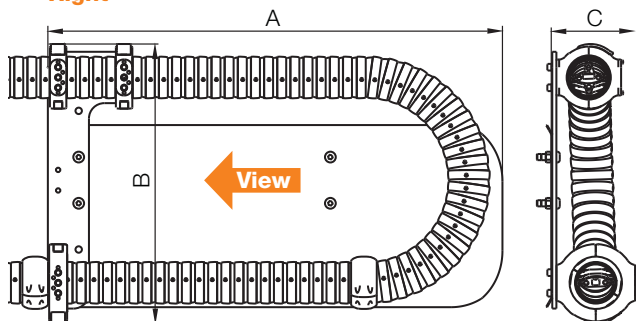

Picture shows triflex® RS - Fastening point, right

## triflex® RS - Fastening point, right

Width Index	Part No. TRC	Part No. TRE	A [mm]	B [mm]	C [mm]
40. ▶	TRC.RS.40.R	TRE.RS.40.R.B	620	301	95
60. ▶	TRC.RS.60.R	TRE.RS.60.R.B	885	528	150
70. ▶	TRC.RS.70.R	TRE.RS.70.R.B	885	545	167
85. ▶	TRC.RS.85.R	TRE.RS.85.R.B	885	565	167
100. ▶	TRC.RS.100.R	TRE.RS.100.R.B	912,5	614	167

## triflex® RS - Fastening point, right, with cover

Width Index	Part No. TRC	Part No. TRE	A [mm]	B [mm]	C [mm]
40. ▶	TRC.RS.40.RC	TRE.RS.40.RC.B	620	301	95
60. ▶	TRC.RS.60.RC	TRE.RS.60.RC.B	885	528	150
70. ▶	TRC.RS.70.RC	TRE.RS.70.RC.B	885	545	167
85. ▶	TRC.RS.85.RC	TRE.RS.85.RC.B	885	565	167
100. ▶	TRC.RS.100.RC	TRE.RS.100.RC.B	912,5	614	167

## triflex® RS - Fastening point, left

Width Index	Part No. TRC	Part No. TRE	A [mm]	B [mm]	C [mm]
40. ▶	TRC.RS.40.L	TRE.RS.40.L.B	620	301	95
60. ▶	TRC.RS.60.L	TRE.RS.60.L.B	885	528	150
70. ▶	TRC.RS.70.L	TRE.RS.70.L.B	885	545	167
85. ▶	TRC.RS.85.L	TRE.RS.85.L.B	885	565	167
100. ▶	TRC.RS.100.L	TRE.RS.100.L.B	912,5	614	167

## triflex® RS - Fastening point, left, with cover

Width Index	Part No. TRC	Part No. TRE	A [mm]	B [mm]	C [mm]
40. ▶	TRC.RS.40.LC	TRE.RS.40.LC.B	620	301	95
60. ▶	TRC.RS.60.LC	TRE.RS.60.LC.B	885	528	150
70. ▶	TRC.RS.70.LC	TRE.RS.70.LC.B	885	545	167
85. ▶	TRC.RS.85.LC	TRE.RS.85.LC.B	885	565	167
100. ▶	TRC.RS.100.LC	TRE.RS.100.LC.B	912,5	614	167

## Further accessories



## RS with cover (barrier)

- Creates more mounting space on robots - e.g. for switch cabinets or valve terminals
- For upside down applications
- Enables the use of RS in applications with extreme movements

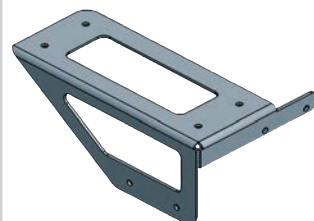

## 43 Adapter brackets from stock

- 43 adapter bracket types for many different robots
- For all RS modules
- For assembly to the side or on top
- Free download of 3D CAD files for many brackets

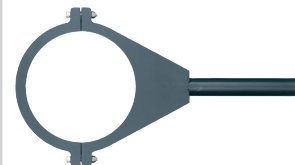
▶ [www.igus.eu/eu/triflexbrackets](http://www.igus.eu/eu/triflexbrackets)

## triflex® R fixation to 6-axis

- One axis diameter (Ø30 mm) for all robots
- Easy and fast assembly
- For triflex® R mounting bracket with CFX clamps and tiewrap plates

## Series TRC/TRE | Accessories

RSP | Intelligent retraction system | for TRC/TRE

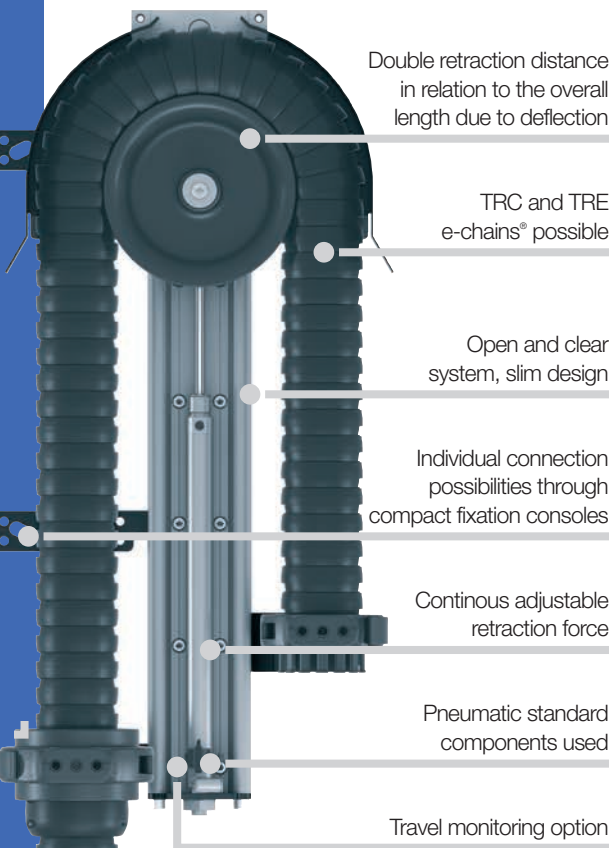

600 mm retraction distance

### RSP - Intelligent retraction system Prevent creation of loops on robot head - now with continuously adjustable retraction force: triflex® RSP

Intelligent retraction system for multi-axial robot applications. Expansion lengths of 600 mm enable a secure guidance of the cables and hoses, even with large arm diameters and very complex movements. The retraction forces can be adjusted with the help of a pneumatic cylinder. Whether light or heavy fillings, long or short robot arms - with the igus® RSP retraction system the retraction force can always be adjusted to the individual application.

- Adjustable, variable retraction force with a pressure control valve
- Almost constant force path over the complete travel, even with heavy fillings
- The end position can be monitored and thereby damage can be prevented
- Greater retraction forces than RS system
- Mounting options for numerous robot types and manufacturers
- 3-6 axis on industrial robots

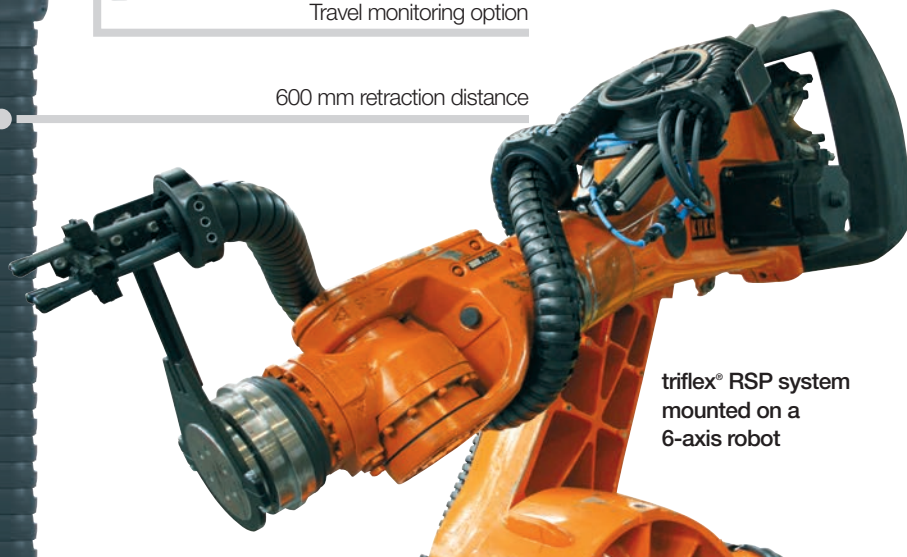

triflex® RSP system  
mounted on a  
6-axis robot

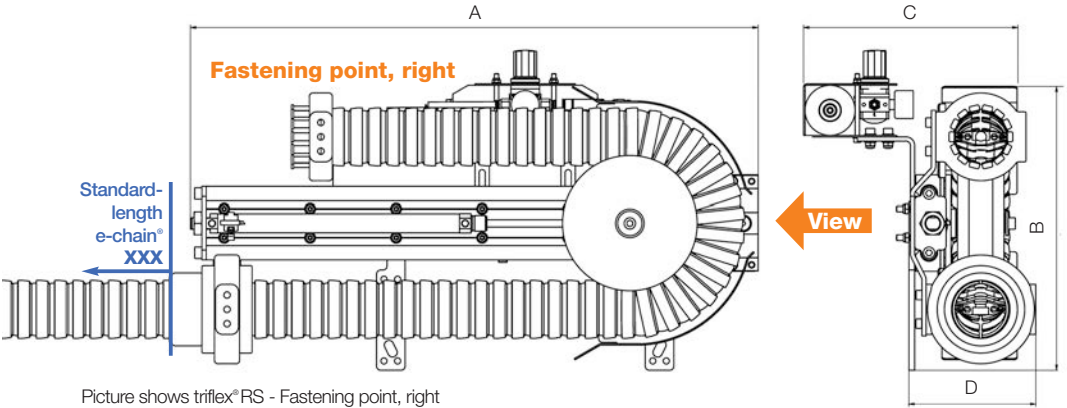

Picture shows triflex® RS - Fastening point, right

Delivery program - RSP pneumatic retraction system

Width Index	Part No. RSP Right system*	Part No. RSP Left system*	Dim. A [mm]	Dim. B [mm]	Dim. C [mm]	Dim. D [mm]
60. ▶	TR.RSP.60.R	TR.RSP.60.L	792	396	324	177
70. ▶	TR.RSP.70.R	TR.RSP.70.L	792	396	324	177
85. ▶	TR.RSP.85.R	TR.RSP.85.L	843	444	363	216
100. ▶	TR.RSP.100.R	TR.RSP.100.L	843	444	363	216
125. ▶	TR.RSP.125.R	TR.RSP.125.L	1031	560	373	226

\*RSP without triflex® R e-chain\*

Delivery program - e-chain® for RSP

Width Index	Part No. TRC Closed design	Part No. TRE "easy"-design	e-chain® standard-length* [mm]			
60. ▶	TRC.RSP.60.087. <b>XXX.0</b>	TRE.RSP.60.087. <b>XXX.0.B</b>	<b>500</b>	<b>1000</b>	<b>1500</b>	<b>2000</b>
70. ▶	TRC.RSP.70.110. <b>XXX.0</b>	TRE.RSP.70.110. <b>XXX.0.B</b>	<b>500</b>	<b>1000</b>	<b>1500</b>	<b>2000</b>
85. ▶	TRC.RSP.85.135. <b>XXX.0</b>	TRE.RSP.85.135. <b>XXX.0.B</b>	<b>500</b>	<b>1000</b>	<b>1500</b>	<b>2000</b>
100. ▶	TRC.RSP.100.145. <b>XXX.0</b>	TRE.RSP.100.145. <b>XXX.0.B</b>	<b>500</b>	<b>1000</b>	<b>1500</b>	<b>2000</b>
125. ▶	TRC.RSP.125.182. <b>XXX.0</b>	TRE.RSP.125.182. <b>XXX.0.B</b>	<b>500</b>	<b>1000</b>	<b>1500</b>	<b>2000</b>

\*Standard lengths (exceeded length from glide lead-through - outside of the system)

Please add the standard-length (measured from the glide lead-through). Example: TRC.RSP.60.087.**500.0**

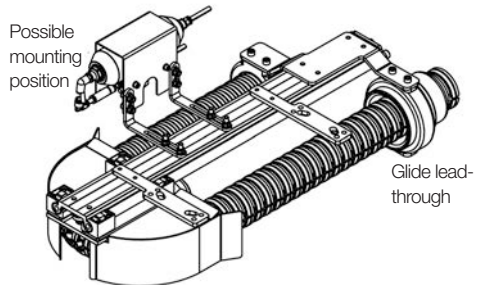
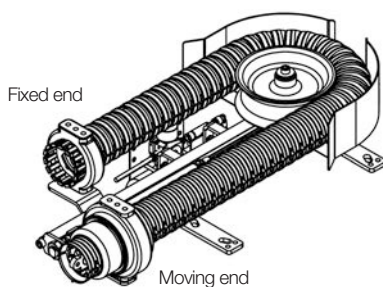

# Series TRC/TRE | Accessories

Fiber rod module | Installation kit | For special applications

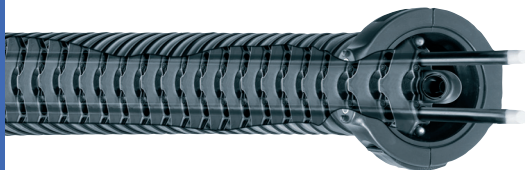

## Fiber rod module | for TRC/TRE

Fiber rod module, for applications where too much flexibility is not desired, intelligent problem solution through directed pretension

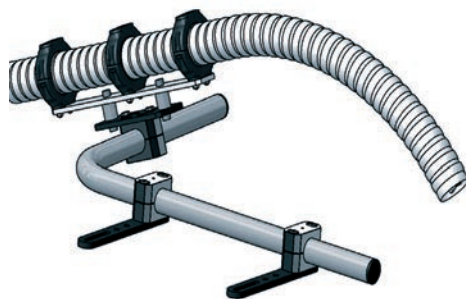

## Delivery program - Fiber rods

Part No. TRC/TRE with mounted fiber rods	Length ca. [m]	
triflex® R 40	TRC.F.40.1000.1.0/TRE.F.40.1000.1.0	1,0
	TRC.F.40.0900.1.0/TRE.F.40.0900.1.0	0,9
	TRC.F.40.0800.1.0/TRE.F.40.0800.1.0*	0,8
	TRC.F.40.0700.1.0/TRE.F.40.0700.1.0	0,7
	TRC.F.40.0600.1.0/TRE.F.40.0600.1.0	0,6
	TRC.F.40.0500.1.0/TRE.F.40.0500.1.0	0,5
	TRC.F.40.0400.1.0/TRE.F.40.0400.1.0	0,4
triflex® R 60	TRC.F.60.1400.1.0/TRE.F.60.1400.1.0	1,4
	TRC.F.60.1200.1.0/TRE.F.60.1200.1.0	1,2
	TRC.F.60.1000.1.0/TRE.F.60.1000.1.0*	1,0
	TRC.F.60.0800.1.0/TRE.F.60.0800.1.0	0,8
	TRC.F.60.0600.1.0/TRE.F.60.0600.1.0	0,6
	TRC.F.60.0400.1.0/TRE.F.60.0400.1.0	0,4
	triflex® R 70	TRC.F.70.1800.1.0/TRE.F.70.1800.1.0
TRC.F.70.1600.1.0/TRE.F.70.1600.1.0		1,6
TRC.F.70.1400.1.0/TRE.F.70.1400.1.0		1,4
TRC.F.70.1200.1.0/TRE.F.70.1200.1.0*		1,2
TRC.F.70.1000.1.0/TRE.F.70.1000.1.0		1,0
TRC.F.70.0800.1.0/TRE.F.70.0800.1.0		0,8
triflex® R 85		TRC.F.85.2000.1.0/TRE.F.85.2000.1.0
	TRC.F.85.1800.1.0/TRE.F.85.1800.1.0	1,8
	TRC.F.85.1600.1.0/TRE.F.85.1600.1.0	1,6
	TRC.F.85.1400.1.0/TRE.F.85.1400.1.0*	1,4
	TRC.F.85.1200.1.0/TRE.F.85.1200.1.0	1,2
	TRC.F.85.1000.1.0/TRE.F.85.1000.1.0	1,0
	TRC.F.85.0800.1.0/TRE.F.85.0800.1.0	0,8
triflex® R 100	TRC.F.100.2000.1.0/TRE.F.100.2000.1.0	2,0
	TRC.F.100.1800.1.0/TRE.F.100.1800.1.0	1,8
	TRC.F.100.1400.1.0/TRE.F.100.1400.1.0*	1,4
	TRC.F.100.1600.1.0/TRE.F.100.1600.1.0	1,6
	TRC.F.100.1200.1.0/TRE.F.100.1200.1.0	1,2
	TRC.F.100.1000.1.0/TRE.F.100.1000.1.0	1,0
	TRC.F.125.2000.1.0/TRE.F.125.2000.1.0	2,0
triflex® R 125	TRC.F.125.1800.1.0/TRE.F.125.1800.1.0*	1,8
	TRC.F.125.1400.1.0/TRE.F.125.1400.1.0	1,4
	TRC.F.125.1600.1.0/TRE.F.125.1600.1.0	1,6
	TRC.F.125.1200.1.0/TRE.F.125.1200.1.0	1,2
	TRC.F.125.1000.1.0/TRE.F.125.1000.1.0	1,0

\*recommended lengths of the fiber rods

## Universal installation kit | for TRC/TRE

Universal installation kit allows the attachment of fiber rod modules in any given position, relative to the robotic arm, easy engineering

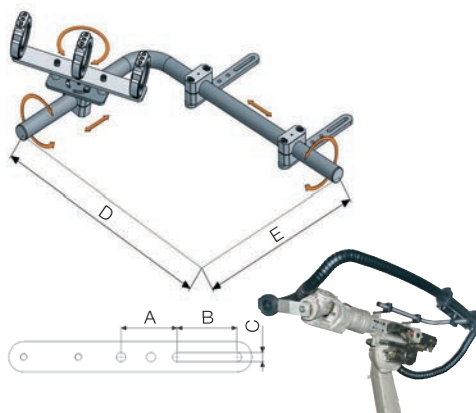

## Delivery program - Universal installation kit

Width index	Part No. kit for Series	A [mm]	B [mm]	D [mm]	E [mm]	C [mm]
.40	▶ TR.40.80	40	30	475	325	8,4
.60	▶ TR.60.80	40	30	475	325	8,4
.70	▶ TR.70.80	75	80	875	575	12,5
.85	▶ TR.85.80	75	80	875	575	12,5
.100	▶ TR.100.80	75	80	875	575	12,5

for width 125 upon request

## Series TRC/TRE/TRL/TRLF | Accessories

## Protective jackets

## Standard protective jacket | TR.XX.16 | for TRC/TRE/TRL/TRLF

- Temperature up to room temp. ● Base support: Fabric ● Coating: None
- Easy to replace via longitudinally positioned velcro fastenings ● Elastic sealing strips
- Silicon-free ● Standard lengths available ex stock

Width index	Part No. TR.XX.16	Standard lengths** [mm]
40.	▶ TR.40.16. YY*	500 1000 1500 2000
60.	▶ TR.60.16. YY*	500 1000 1500 2000
70.	▶ TR.70.16. YY*	500 1000 1500 2000
85.	▶ TR.85.16. YY*	500 1000 1500 2000
100.	▶ TR.100.16.YY*	500 1000 1500 2000
125.	▶ TR.125.16.YY*	500 1000 1500 2000

\*Please add the jacket length. Example: TR.60.16.500

\*\*special lengths upon request



## Heat shield protective jacket | TR.XX.18 | for TRC/TRE/TRL/TRLF

- Made from heat resistant, abrasion resistant Kevlar weave ● With aluminum laminate ● With zip-closure ● Velcro fasteners at the beginning and end ● Heavy-duty (thick) design ● Protects from perspiration and metal spatter briefly up to 540°C ● Easy to exchange or retrofit ● Silicone-free ● Asbestos-free ● Standard lengths from stock ● High abrasion resistance ● Very tight ● For heavy-duty environments

Width index	Part No. TR.XX.18	Standard lengths** [mm]
40.	▶ TR.40.18. YY*	500 1000 1500 2000
60.	▶ TR.60.18. YY*	500 1000 1500 2000
70.	▶ TR.70.18. YY*	500 1000 1500 2000
85.	▶ TR.85.18. YY*	500 1000 1500 2000
100.	▶ TR.100.18.YY*	500 1000 1500 2000
125.	▶ TR.125.18.YY*	500 1000 1500 2000

\*Please add the jacket length. Example: TR.60.18.500

\*\*special lengths upon request



## Wear-resistant shield - TR.XX.19 | for TRC/TRE/TRL/TRLF

- Black leather material with zip-closure ● Velcro fasteners at the beginning and end
- Extremely high abrasion resistance ● For use in temperatures from -40°C to + 100°C ● Silicone-free
- Asbestos-free ● Standard lengths from stock ● Very flexible ● Easy to exchange or retrofit

Width index	Part No. TR.XX.19	Standard lengths** [mm]
40.	▶ TR.40.19. YY*	500 1000 1500 2000
60.	▶ TR.60.19. YY*	500 1000 1500 2000
70.	▶ TR.70.19. YY*	500 1000 1500 2000
85.	▶ TR.85.19. YY*	500 1000 1500 2000
100.	▶ TR.100.19.YY*	500 1000 1500 2000
125.	▶ TR.125.19.YY*	500 1000 1500 2000

\*Please add the jacket length. Example: TR.60.19.500

\*\*special lengths upon request



# easy triflex® | Introduction | Advantages

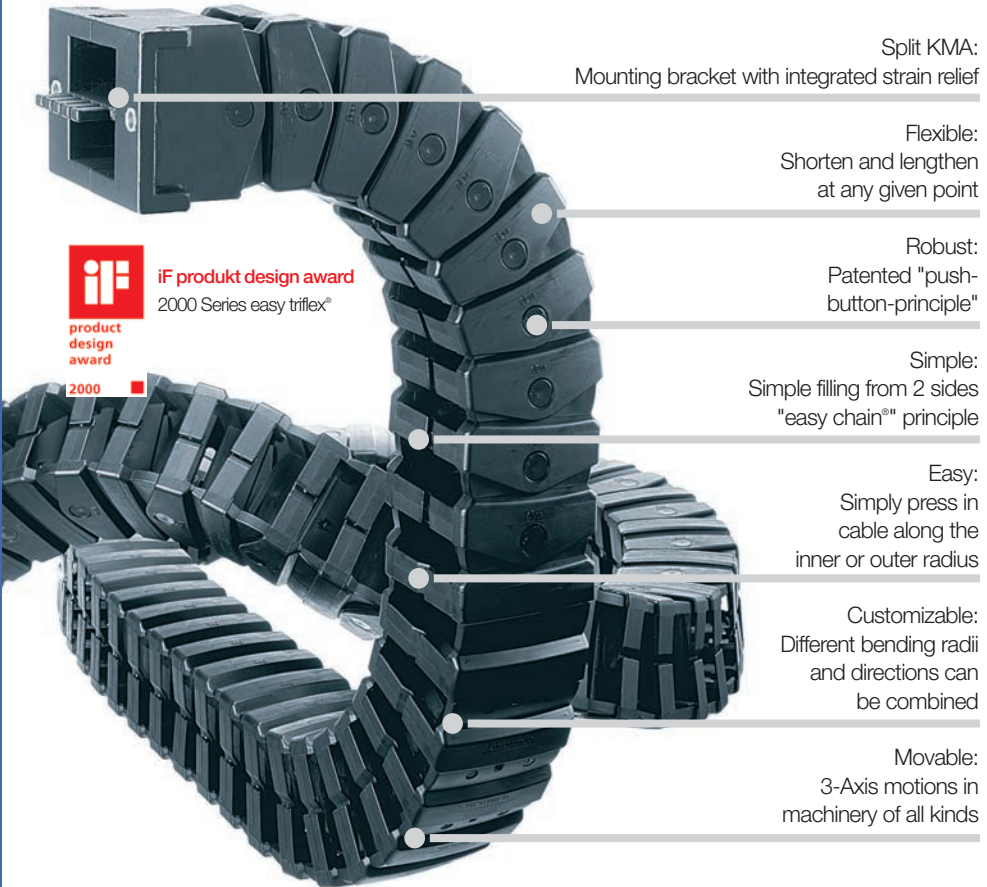

iF produkt design award  
2000 Series easy triflex®

product  
design  
award

2000

Split KMA:  
Mounting bracket with integrated strain relief

Flexible:  
Shorten and lengthen  
at any given point

Robust:  
Patented "push-  
button-principle"

Simple:  
Simple filling from 2 sides  
"easy chain®" principle

Easy:  
Simply press in  
cable along the  
inner or outer radius

Customizable:  
Different bending radii  
and directions can  
be combined

Movable:  
3-Axis motions in  
machinery of all kinds

## easy triflex® - for 3D-applications

The easy triflex® Series was developed to realize safe energy supply in the case of multi-dimensional movements. In doing so the flexibility of a hose was combined with the stability of an e-chain® and its defined radii. With the easy triflex® the installation of cables, wires and hoses is very easy. In case of flexible cross-bars the cables are now simply pushed into the e-chain® from above or below. The unique modular program allows you to follow very complex movements. For Example: Combine 1-axis, 2-axis and 3-axis movement links in one e-chain®.

### Typical industries and applications

- Machine tools ● Robots ● Handling equipment ● Material handling
- Plastics machinery ● Construction machines ● Vehicles
- Machinery of all kinds ● Medical equipment ● Office furniture



Torsional motion  
possible



UL94-V2  
classifications



# easy triflex® | Selection Table

Series	Inner height <i>Bi 1/Bi 2</i> [mm]	Inner width <i>Bi 3</i> [mm]	Outer width/ height <i>Ba</i> [mm]	Bending radii <i>R</i> [mm]	Pitch [mm]	Page
--------	---------------------------------------	---------------------------------	---------------------------------------	--------------------------------	---------------	------



## Single-axis movement.

For 3D-applications,  
simple filling from 2 sides

E332.25	13	25	34	048 - 200	14,5	576
E332.32	17	32	50	075 - 250	25	576
E332.50	26	50	68	100 - 250	30	576
E332.75	38,5	75	96	140 - 300	36	576



## Double-axis movement.

For 3D-applications,  
simple filling from 2 sides

E332.25	13	25	34	048 - 200	14,5	577
E332.32	17	32	50	075 - 250	25	577
E332.50	26	50	68	100 - 250	30	577
E332.75	38,5	75	96	140 - 300	36	577





## Triple-axis movement.

For 3D-applications,  
simple filling from 2 sides

E333.25	13	25	34	048 - 200	14,5	578
E333.32	17	32	50	075 - 250	25	578
E333.50	26	50	68	100 - 250	30	578
E333.75	38,5	75	96	140 - 300	36	578



## Technical Data

	Speed / acceleration	upon request
	Material - permitted temperature °C, igumid NB	-40° up to +80°C
	Flammability class, igumid NB	VDE 0304 IIC UL94-V2

## Order example | Order key and color options based on Series E333

 **Order example for complete e-chain® (1,0 m), color black, with mounting brackets:**

e-chain® (1,0 m)	Please indicate e-chain® length or number of links: 1,0 m or 27 links	<b>E333.75.200/200.0</b>
<b>+ Mounting brackets</b>	1 set mounting bracket with strain relief	<b>333.75.12PZ</b>

Order text: 1,0 m E333.75.200/200.0 + 333.75.12PZ

 **Order key** **E332.2.75.200.0**

Series 

Width index  $\emptyset$  

Bending radius *R* 

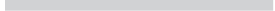
Standard color black 

### Single-axis movement

Series E332 for simple filling from 2 sides with *Bi 75* mm inner width and *R 200* mm radius, color black  
= Part No. E332.2.75.200.0

 **Order key** **E332.2.75.200/200.0**

Series 

Width index  $\emptyset$  

Bending radius *R* 

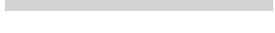
Bending radius *RBR* 

Standard color black 

### Double-axis movement

Series E332 for simple filling from 2 sides with *Bi 75* mm inner width and *R 200* mm radius, *RBR 200* mm, color black  
= Part No. E332.2.75.200/200.0

 **Order key** **E333.75.200/200.0**

Series 

Width index  $\emptyset$  

Bending radius *R* 

Bending radius *RBR* 

Standard color black 

### Triple-axis movement

Series E333 for simple filling from 2 sides with *Bi 75* mm inner width and *R 200* mm radius, *RBR 200* mm, color black  
= Part No. E333.75.200/200.0



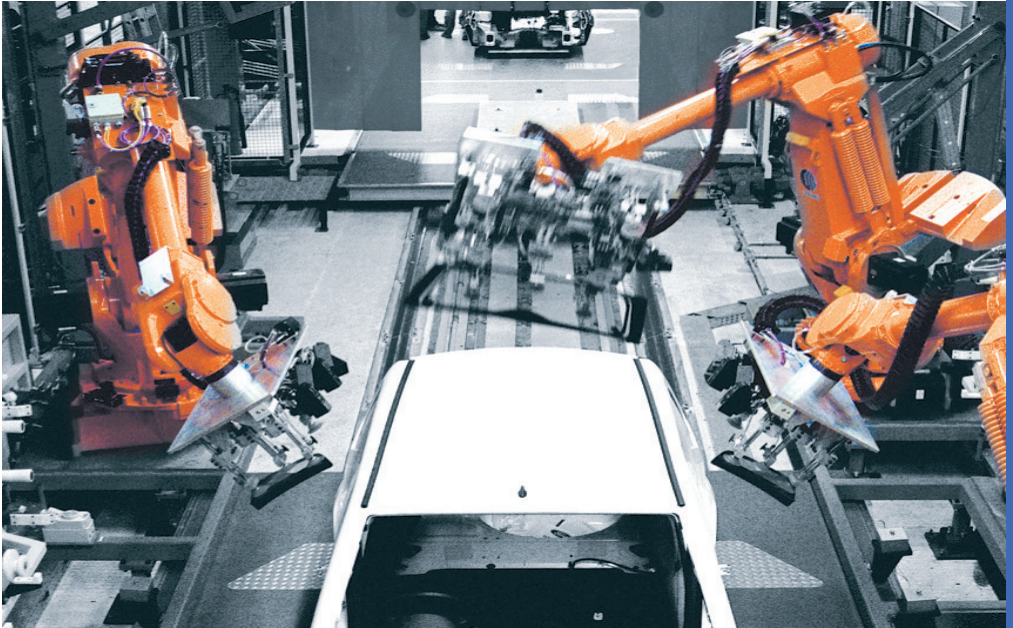

Robots with igus® easy triflex® e-chains® on an assembly line



easy triflex® e-chains® for multi-dimensional movements on a production line



easy triflex® e-chains® also for easy applications - here an aesthetic application

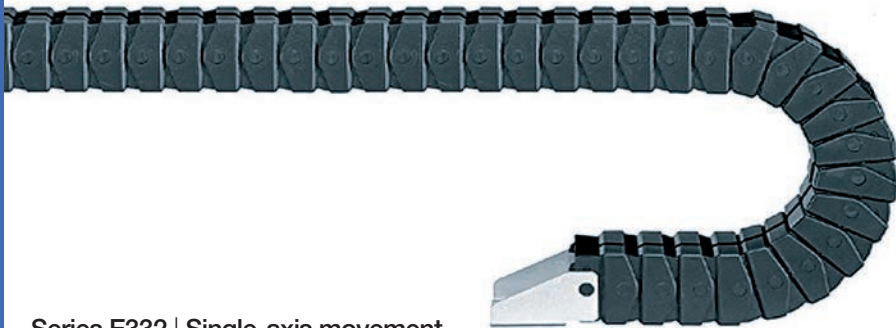

## Series E332 | Single-axis movement

Simple filling from 2 sides	Bi1/Bi2 [mm]	Bi3 [mm]	Ba [mm]	R Bending radii [mm]	Pitch [mm]	Weight [kg/m]
E332.25.2.R.0	13	25	34	048   075   100   125   150   175   200	14,5	≈ 0,70
E332.32.2.R.0	17	32	50	075   100   125   150   200   250	25	≈ 0,90
E332.50.2.R.0	26	50	68	100   125   150   200   250	30	≈ 1,40
E332.75.2.R.0	38,5	75	96	140   175   200   250   300	36	≈ 2,35

Supplement Part No. with required radius (R) Example: E332.75.2.200.0

## Dimensions

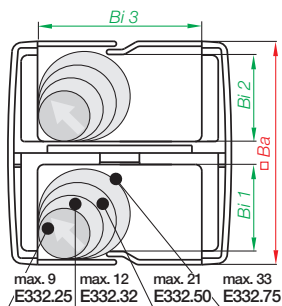
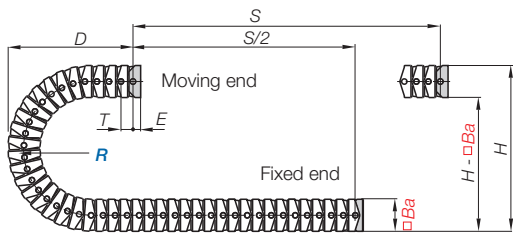

E332.25.2	R	048	075	100	125	150	175	200
	H	130	185	235	285	335	385	435
	D	095	125	150	175	200	225	250
	K	195	280	360	440	515	595	675
E332.32.2	R	075	100	125	150	200	250	
	H	200	250	300	350	450	550	
	D	130	155	180	205	255	305	
	K	305	385	465	545	700	865	
E332.50.2	R	100	125	150	200	250		
	H	270	320	375	470	570		
	D	195	220	245	295	345		
	K	435	520	590	750	910		
E332.75.2	R	140	175	200	250	300		
	H	380	450	500	600	700		
	D	240	275	300	350	400		
	K	550	660	740	900	1060		

### Series E332.25.2.

Ba	34 mm
Pitch T	14,5 mm/link
Links/m	69 (1000,5 mm)
Dim. E	10 mm
Chain length	$\frac{S}{2} + K$

### Series E332.32.2.

Ba	50 mm
Pitch T	25 mm/link
Links/m	40 (1000 mm)
Dim. E	20 mm
Chain length	$\frac{S}{2} + K$

### Series E332.50.2.

Ba	68 mm
Pitch T	30 mm/link
Links/m	34 (1020 mm)
Dim. E	25 mm
Chain length	$\frac{S}{2} + K$

### Series E332.75.2.

Ba	96 mm
Pitch T	36 mm/link
Links/m	28 (1008 mm)
Dim. E	25 mm
Chain length	$\frac{S}{2} + K$



Series E332 | Double-axis movement | With **RBR** (Reversal Bending Radius)

Simple filling from 2 sides	Bi1/Bi2 [mm]	Bi3 [mm]	Ba [mm]	R Bending radii [mm]						Pitch [mm]	Weight [kg/m]	
E332.25.2 .R/R.0	13	25	34	048	075	100	125	150	175	200	14,5	≈ 0,70
E332.32.2 .R/R.0	17	32	50	075	100	125	150	200	250	25	≈ 0,90	
E332.50.2 .R/R.0	26	50	68	100	125	150	200	250		30	≈ 1,40	
E332.75.2 .R/R.0	38,5	75	96	140	175	200	250	300		36	≈ 2,35	

Supplement Part No. with required radius (R) Example: E332.75.2.200/200.0

Dimensions

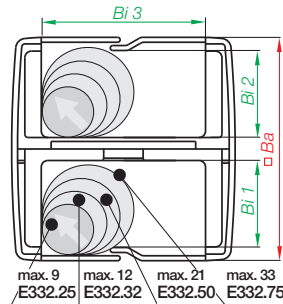
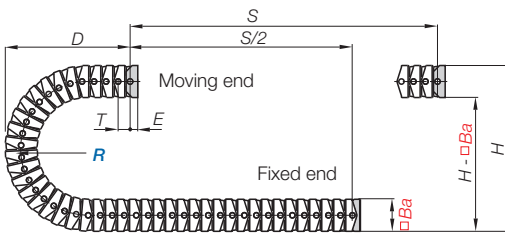

E332.25.2	R	048	075	100	125	150	175	200
	H	130	185	235	285	335	385	435
	D	095	125	150	175	200	225	250
E332.32.2	K	195	280	360	440	515	595	675
	R	075	100	125	150	200	250	
	H	200	250	300	350	450	550	
E332.50.2	D	130	155	180	205	255	305	
	K	305	385	465	545	700	865	
	R	100	125	150	200	250		
E332.75.2	H	270	320	375	470	570		
	D	195	220	245	295	345		
	K	435	520	590	750	910		
E332.75.2	R	140	175	200	250	300		
	H	380	450	500	600	700		
	D	240	275	300	350	400		
K	550	660	740	900	1060			

Series E332.25.2.

Ba	34 mm
Pitch T	14,5 mm/link
Links/m	69 (1000,5 mm)
Dim. E	10 mm
Chain length	$S/2 + K$

Series E332.32.2.

Ba	50 mm
Pitch T	25 mm/link
Links/m	40 (1000 mm)
Dim. E	20 mm
Chain length	$S/2 + K$

Series E332.50.2.

Ba	68 mm
Pitch T	30 mm/link
Links/m	34 (1020 mm)
Dim. E	25 mm
Chain length	$S/2 + K$

Series E332.75.2.

Ba	96 mm
Pitch T	36 mm/link
Links/m	28 (1008 mm)
Dim. E	25 mm
Chain length	$S/2 + K$



## Series E333 | Triple-axis movement | With **RBR** (Reversal Bending Radius)

Simple filling from 2 sides	Bi1/Bi2 [mm]	Bi3 [mm]	Ba [mm]	R Bending radii [mm]	Pitch [mm]	Weight [kg/m]
E333.25 .R/R.0	13	25	34	048   075   100   125   150   175   200	14,5	≈ 0,70
E333.32 .R/R.0	17	32	50	075   100   125   150   200   250	25	≈ 0,90
E333.50 .R/R.0	26	50	68	100   125   150   200   250	30	≈ 1,40
E333.75 .R/R.0	38,5	75	96	140   175   200   250   300	36	≈ 2,35

The bending radii are doubled in the case of the Series E333 !

Supplement Part No. with required radius (R) Example: E333.75.200/200.0

### Dimensions

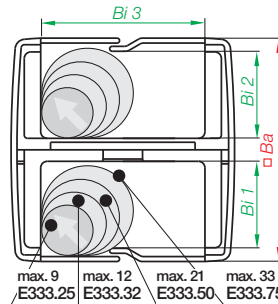
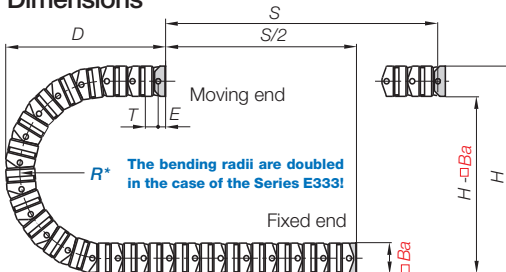

<b>E333.25.</b>	R	048	075	100	125	150	175	200
	H	230	335	435	535	635	735	835
	D	145	200	250	300	350	400	450
	K	350	515	675	830	990	1150	1300
<b>E333.32.</b>	R	075	100	125	150	200	250	
	H	350	450	550	650	850	1050	
	D	205	255	305	355	455	555	
	K	545	700	860	1020	1300	1605	
<b>E333.50.</b>	R	100	125	150	200	250		
	H	470	570	670	870	1070		
	D	295	345	395	495	595		
	K	750	910	1070	1380	1690		
<b>E333.75.</b>	R	140	175	200	250	300		
	H	660	800	900	1100	1300		
	D	380	450	500	600	700		
	K	990	1210	1400	1700	2000		

#### Series E333.25

Ba	34 mm
Pitch T	14,5 mm/link
Links/m	69 (1000,5 mm)
Dim. E	10 mm
Chain length	$\frac{S}{2} + K$

#### Series E333.32

Ba	50 mm
Pitch T	25 mm/link
Links/m	40 (1000 mm)
Dim. E	20 mm
Chain length	$\frac{S}{2} + K$

#### Series E333.50

Ba	68 mm
Pitch T	30 mm/link
Links/m	34 (1020 mm)
Dim. E	25 mm
Chain length	$\frac{S}{2} + K$

#### Series E333.75

Ba	96 mm
Pitch T	36 mm/link
Links/m	28 (1008 mm)
Dim. E	25 mm
Chain length	$\frac{S}{2} + K$

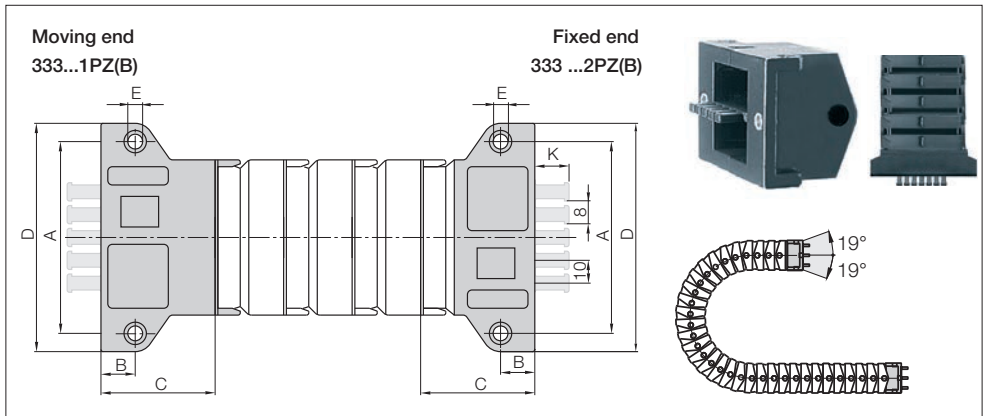

**KMA, one side pivoting**

Width Index	Part No. full set with tiewrap plates	Part No. full set without tiewrap plates	Dim A [mm]	Dim B [mm]	Dim C [mm]	Dim D [mm]	Dim E [mm]	Dim F [mm]	Number of teeth
25.2 / 25. ▶	-	333.25.12PZ	43	7	22	52	4,5	-	-
32.2 / 32. ▶	333.32.12PZB	333.32.12PZ	66	15	46	82	6,5	15	3
50.2 / 50. ▶	333.50.12PZB	333.50.12PZ	84	15	50	100	6,5	15	5
75.2 / 75. ▶	333.75.12PZB	333.75.12PZ	109	15	55	125	6,5	15	7

(KMA = Polymer Metal Mounting Bracket)

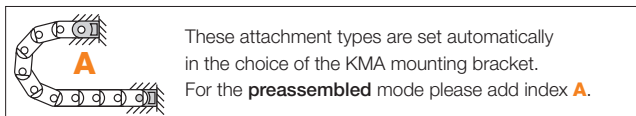

**Part No. structure**

**333.75.12PZBA**

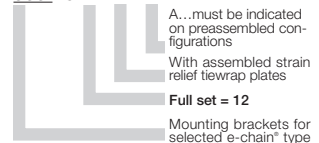

 **Strain relief** e.g. clamps, tiewrap plates, nuggets and plug-in clips are available from stock. The complete chainfix range with order options ▶ from page 630

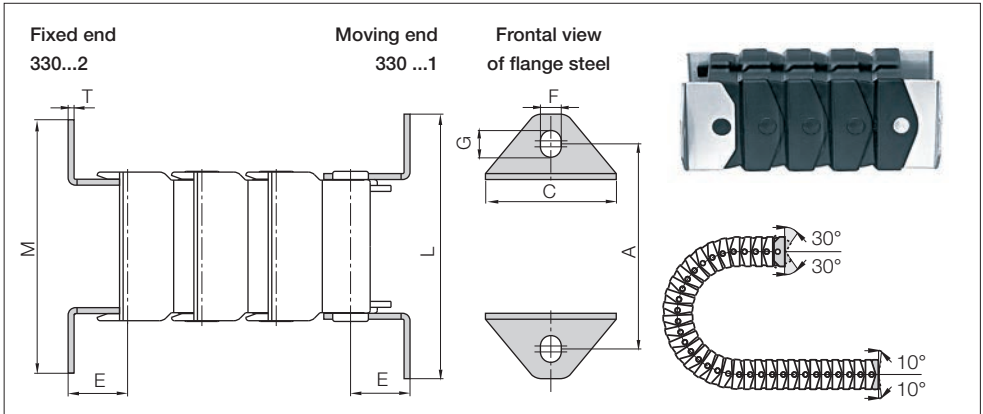

### Flange steel | pivoting

Width Index	Part No. full set	Dim A [mm]	Dim M [mm]	Dim C [mm]	Dim L [mm]	Dim T [mm]	Dim E [mm]	Dim F [mm]	Dim G [mm]
25.2 / 25.	▶ 330.25.12	44	55	29	55	1,5	10,5	6,5	9
32.2 / 32.	▶ 330.32.12	66	84	44	88	2	20	7	9
50.2 / 50.	▶ 330.50.12	84	102	62	106	2	25	7	9
75.2 / 75.	▶ 330.75.12	109	127	90	131	2	25	7	9

#### Part No. structure

**330.75.12 A**

A...must be indicated on preassembled configurations

Full set = 12

Width

Mounting brackets for selected e-chain\* type

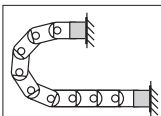

Frontal attachment option in the case of steel flange mounting brackets.

For the **preassembled** mode please add index **A**.



**Strain relief** e.g. clamps, tiewrap plates, nuggets and plug-in clips are available from stock. The complete chainfix range with order options ▶ from page 630

Mounting brackets, angled, steel | pivoting

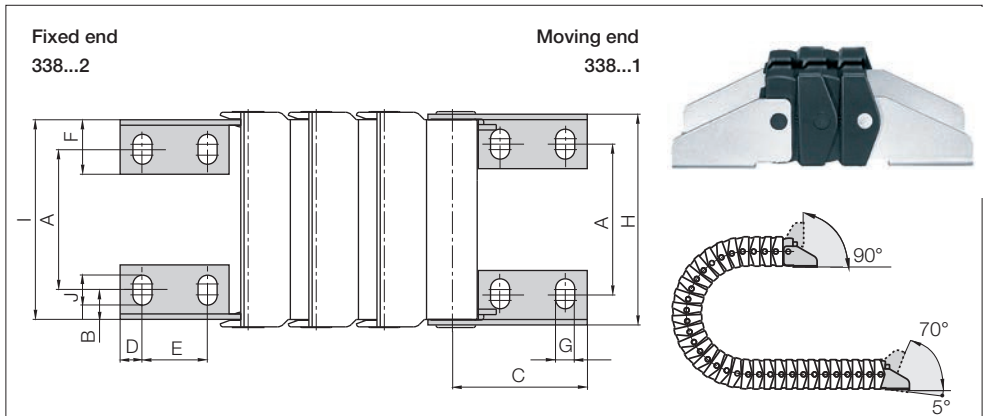

Angled steel bracket | pivoting

Width Index	Part No. full set	Dim A [mm]	Dim B [mm]	Dim C [mm]	Dim D [mm]	Dim E [mm]	Dim F [mm]	Dim G [mm]	Dim H [mm]	Dim I [mm]	Dim J [mm]
25.2 / 25. ▶	<b>338.25.12</b>	17	6,25	28	6	16	14	5,5	33,8	31	8,5
32.2 / 32. ▶	<b>338.32.12</b>	24	5,5	47	8	24	20	7	49	45	11
50.2 / 50. ▶	<b>338.50.12</b>	42	5,5	77	12	35	24	9	67	62	15
75.2 / 75. ▶	<b>338.75.12</b>	65	5,5	77	12	35	24	9	95	90	15

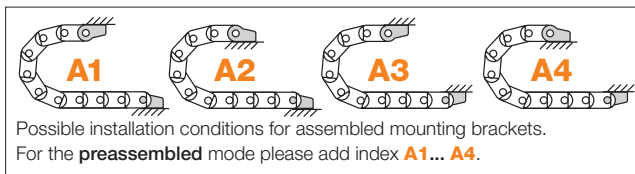

Part No. structure

**338. 75. 12 A**

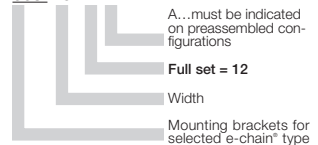

 **Strain relief** e.g. clamps, tie-wrap plates, nuggets and plug-in clips are available from stock. The complete chainfix range with order options ▶ from page 630

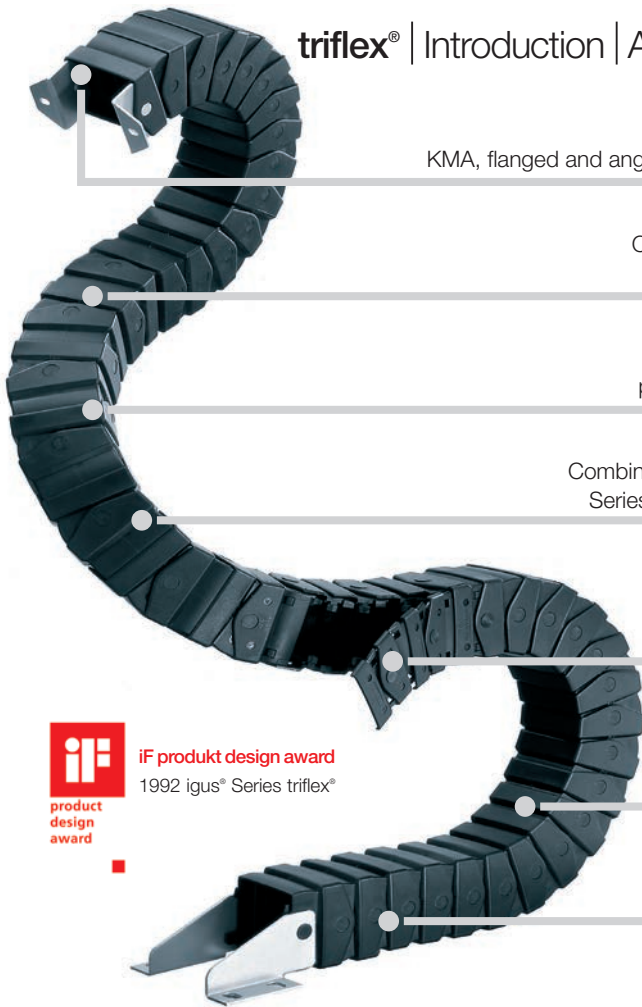

Universal:  
KMA, flanged and angled mounting brackets available

Customizable:  
Combinations of varying bending radii and moving axes

Protection:  
Completely enclosed - protection against dirt and chips

Modular:  
Combination of triple axis fully enclosed Series and snap open series possible

Variation:  
Series 352 and 353 snap-open, 50 mm cross-section

Effective:  
Cost-effective design for complex movements

Flexible:  
Assembling and separating at any given point



iF produkt design award  
1992 igus® Series triflex®

## triflex® - enclosed for 3D-applications

triflex® - e-chain® for 3D-motion. The triflex® Series was developed to realize safe energy supply in the case of multi-dimensional movements. In doing so the flexibility of a hose was combined with the stability of an e-chain® and its defined radii. The unique modular program allows you to follow very complex movements. For example: Combine 1-axis, 2-axis and 3-axis movement links in one e-chain®.

### Typical industries and applications

- Machine tools ● Robots ● Handling equipment ● Material handling
- Plastics machinery ● Construction machines ● Vehicles
- Machinery of all kinds ● Medical equipment ● Office furniture



Torsional motion possible





Series	Inner width/height □ $B_i$ [mm]	Outer width/height □ $B_a$ [mm]	Bending radii $R$ [mm]	Pitch [mm]	Page
--------	------------------------------------	------------------------------------	---------------------------	---------------	------



**Single-axis movement.**  
For 3D-applications,  
Series 332 fully enclosed -  
protection against dirt and chips.  
\*Series 352 snap-open

332.16	16	26	038 - 100	13,3	586
332.32	32	50	075 - 250	25	586
332.50	50	68	100 - 250	30	586
332.75	75	96	140 - 300	36	586
352.50*	50	68	100 - 250	30	586



**Double-axis movement.**  
For 3D-applications,  
Series 332 fully enclosed -  
protection against dirt and chips.  
\*Series 352 snap-open

332.16	16	26	038 - 100	13,3	588
332.32	32	50	075 - 250	25	588
332.50	50	68	100 - 250	30	588
332.75	75	96	140 - 300	36	588
352.50*	50	68	100 - 250	30	588



**Triple-axis movement.**  
For 3D-applications,  
Series 333 fully enclosed -  
protection against dirt and chips.  
\*Series 353 snap-open

333.16	16	26	038 - 100	13,3	589
333.32	32	50	075 - 250	25	589
333.50	50	68	100 - 250	30	589
333.75	75	96	140 - 300	36	589
353.50*	50	68	100 - 250	30	589

## Technical Data

	Speed / acceleration	upon request
	Material - permitted temperature °C, igumid G	-40° up to +120°C
	Flammability class, igumid G	VDE 0304 IIC UL94-HB

## Order example | Order key and color options based on Series 332

 **Order example for complete e-chain® (1,0 m), color black, with mounting brackets:**

<b>e-chain®</b> (1,0 m)	Please indicate e-chain® length or number of links: 1,0 m or 28 links	<b>332.75.200/200.0</b>
<b>+ Mounting brackets</b>	1 set mounting bracket with strain relief	<b>333.75.12PZ</b>
<b>+ Interior separation</b>	with 2 separators assembled every 2 <sup>nd</sup> link	<b>351</b>

Order text: 1,0 m 333.75.200/200.0 + 333.75.12PZ + 351

 **Order key**

**332.75.200.0**  
**352.50.200.0**

Series

Width index Ø

Bending radius **R**

Standard color black



### Single-axis movement

Series 332 fully enclosed  
with **Bi 75** mm inner width and **R 200** mm radius, color black  
= Part No. **332.75.200.0**

Series 352 snap-open  
with **Bi 50** mm inner width and **R 200** mm radius, color black  
= Part No. **352.50.200.0**

 **Order key**

**332.75.200/200.0**  
**352.75.200/200.0**

Series

Width index Ø

Bending radius **R**

Bending radius **RBR**

Standard color black



### Double-axis movement

Series 332 fully enclosed  
with **Bi 75** mm inner width and **R 200** mm radius,  
**RBR 200** mm, color black = Part No. **332.75.200/200.0**

Series 352 snap-open  
with **Bi 50** mm inner width and **R 200** mm radius,  
**RBR 200** mm, color black = Part No. **352.50.200/200.0**

 **Order key**

**333.75.200/200.0**  
**353.75.200/200.0**

Series

Width index Ø

Bending radius **R**

Bending radius **RBR**

Standard color black



### Triple-axis movement

Series 333 fully enclosed  
with **Bi 75** mm inner width and **R 200** mm radius,  
**RBR 200** mm, color black = Part No. **333.75.200/200.0**

Series 353 snap-open  
with **Bi 50** mm inner width and **R 200** mm radius,  
**RBR 200** mm, color black = Part No. **353.50.200/200.0**

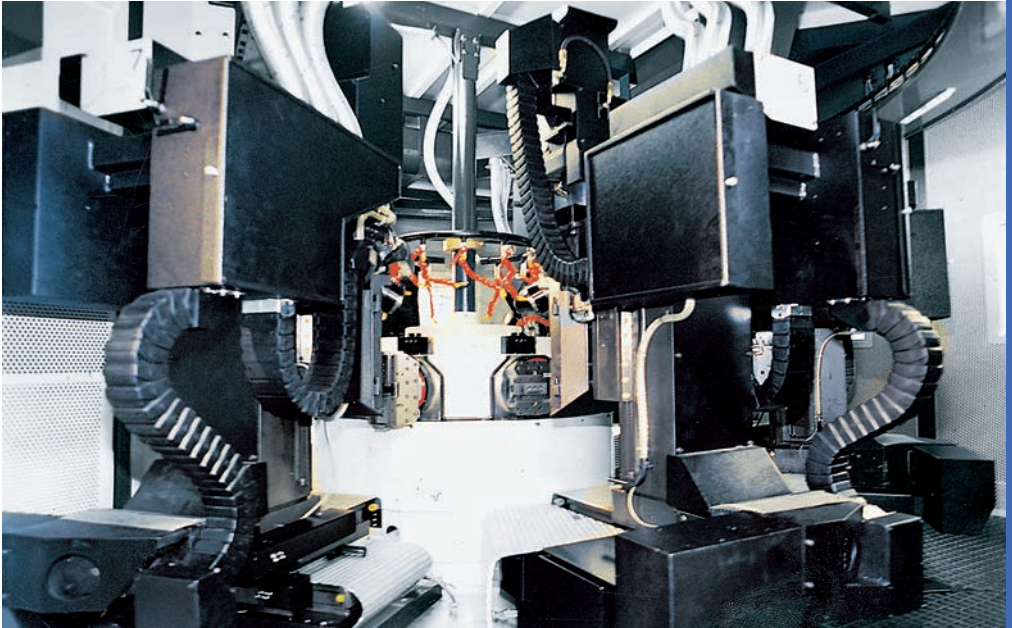

Various triflex® e-tubes on the inside of a machining center

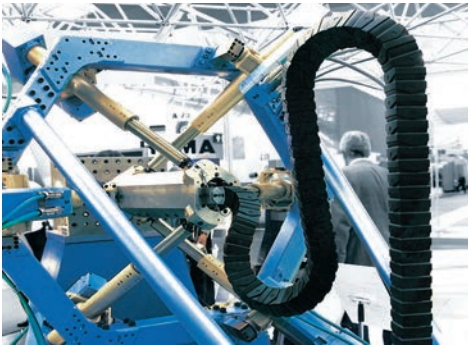

triflex® for 3 movement directions combined with triflex® for 1 movement direction



triflex® 332 as unsupported link from machines to control desk



## Series 332 | 352 | Single-axis movement

Series 332 Fully enclosed	Series 352 Snap-open	<i>Bi</i> [mm]	<i>Ba</i> [mm]	<i>R</i> Bending radii [mm]	Pitch [mm]	Weight [kg/m]
332.16 .R.0	–	16	26	038   048   075   100	13,3	0,33
332.32 .R.0	–	32	50	075   100   125   150   200   250	25	0,90
332.50 .R.0	352.50 .R.0	50	68	100   125   150   200   250	30	1,40
332.75 .R.0	–	75	96	140   175   200   250   300	36	2,35

Supplement Part No. with required radius (*R*) Example: 332.75.200.0

## Dimensions

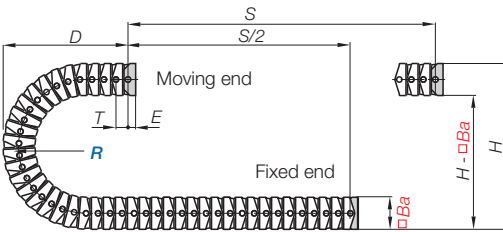

332.16	<i>R</i>	038	048	075	100		
	<i>H</i>	105	125	180	230		
	<i>D</i>	070	080	105	130		
332.32	<i>K</i>	200	230	315	400		
	<i>R</i>	075	100	125	150	200	250
	<i>H</i>	200	250	300	350	450	550
332.50/352.50	<i>D</i>	130	155	180	205	255	305
	<i>K</i>	305	385	465	545	700	865
	<i>R</i>	100	125	150	200	250	
332.75	<i>H</i>	270	320	375	470	570	
	<i>D</i>	195	220	245	295	345	
	<i>K</i>	435	520	590	750	910	
332.75	<i>R</i>	140	175	200	250	300	
	<i>H</i>	380	450	500	600	700	
	<i>D</i>	240	275	300	350	400	
332.75	<i>K</i>	550	660	740	900	1060	

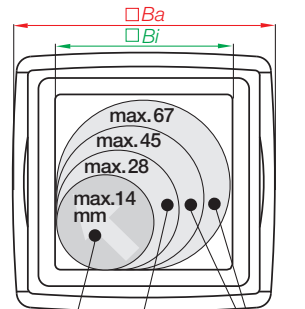

332.16 / 332.32 / 332./352.50 / 332.75

## Series 332.16

<i>Ba</i>	26 mm
Pitch <i>T</i>	13,3 mm/link
Links/m	76 (1011 mm)
Dim. <i>E</i>	10 mm
Chain length	$\frac{S}{2} + K$

## Series 332.32

<i>Ba</i>	50 mm
Pitch <i>T</i>	25 mm/link
Links/m	40 (1000 mm)
Dim. <i>E</i>	20 mm
Chain length	$\frac{S}{2} + K$

## Series 332.50/352.50

<i>Ba</i>	68 mm
Pitch <i>T</i>	30 mm/link
Links/m	34 (1020 mm)
Dim. <i>E</i>	25 mm
Chain length	$\frac{S}{2} + K$

## Series 332.75

<i>Ba</i>	96 mm
Pitch <i>T</i>	36 mm/link
Links/m	28 (1008 mm)
Dim. <i>E</i>	25 mm
Chain length	$\frac{S}{2} + K$

Unsupported applications | Short travels - for single axis only!

Unsupported length 332.16

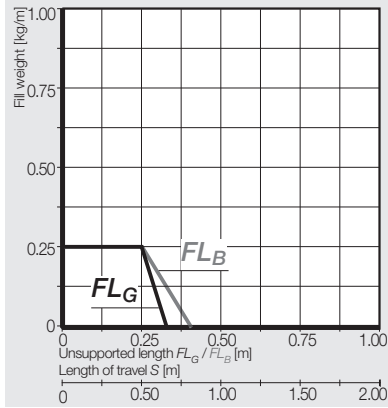

Unsupported length 332.32

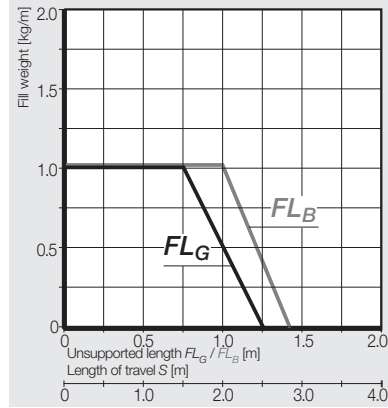

Unsupported length 332.50/352.50

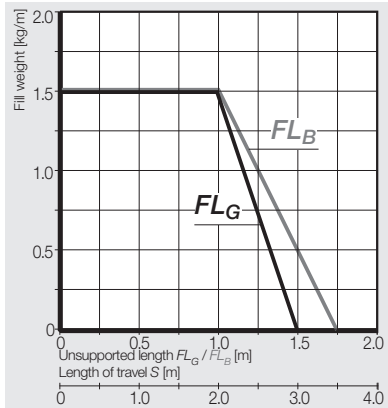

Unsupported length 332.75

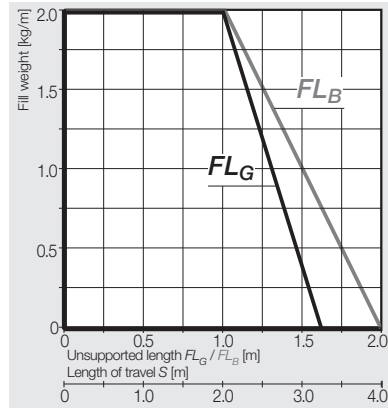



Series 332 | 352 | Double-axis movement | With **RRB** (Reversal Bending Radius)

Series 332 Fully enclosed	Series 352 Snap-open	<i>Bi</i> [mm]	<i>Ba</i> [mm]	<i>R</i> Bending radii [mm]	Pitch [mm]	Weight [kg/m]
332.16. <i>R/R</i> .0	-	16	26	038   048   075   100	13,3	0,33
332.32. <i>R/R</i> .0	-	32	50	075   100   125   150   200   250	25	0,90
332.50. <i>R/R</i> .0	352.50. <i>R/R</i> .0	50	68	100   125   150   200   250	30	1,40
332.75. <i>R/R</i> .0	-	75	96	140   175   200   250   300	36	2,35

Supplement Part No. with required radius (*R*) Example: 332.75.200/200.0

Dimensions

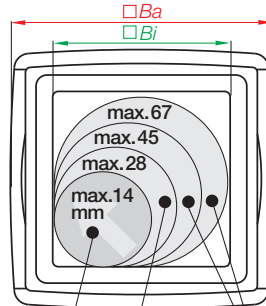
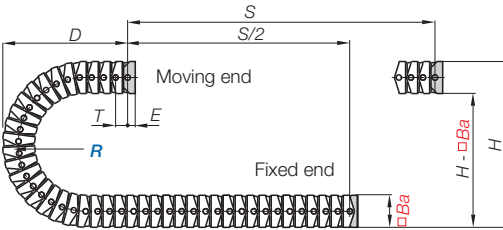

332.16 / 332.32 / 332./352.50 / 332.75

332.16	<i>R</i>	038	048	075	100		
	<i>H</i>	105	125	180	230		
	<i>D</i>	070	080	105	130		
332.32	<i>K</i>	200	230	315	400		
	<i>R</i>	075	100	125	150	200	250
	<i>H</i>	200	250	300	350	450	550
332.50/352.50	<i>D</i>	130	155	180	205	255	305
	<i>K</i>	305	385	465	545	700	865
	<i>R</i>	100	125	150	200	250	
332.75	<i>H</i>	270	320	375	470	570	
	<i>D</i>	195	220	245	295	345	
	<i>K</i>	435	520	590	750	910	
332.75	<i>R</i>	140	175	200	250	300	
	<i>H</i>	380	450	500	600	700	
	<i>D</i>	240	275	300	350	400	
332.75	<i>K</i>	550	660	740	900	1060	

Series 332.16

<i>Ba</i>	26 mm
Pitch <i>T</i>	13,3 mm/link
Links/m	76 (1011 mm)
Dim. <i>E</i>	10 mm
Chain length	$\frac{S}{2} + K$

Series 332.32

<i>Ba</i>	50 mm
Pitch <i>T</i>	25 mm/link
Links/m	40 (1000 mm)
Dim. <i>E</i>	20 mm
Chain length	$\frac{S}{2} + K$

Series 332.50/352.50

<i>Ba</i>	68 mm
Pitch <i>T</i>	30 mm/link
Links/m	34 (1020 mm)
Dim. <i>E</i>	25 mm
Chain length	$\frac{S}{2} + K$

Series 332.75

<i>Ba</i>	96 mm
Pitch <i>T</i>	36 mm/link
Links/m	28 (1008 mm)
Dim. <i>E</i>	25 mm
Chain length	$\frac{S}{2} + K$



Series 333 | 353 | Triple-axis movement | With **RBR** (Reversal Bending Radius)

Series 332 Fully enclosed	Series 353 Snap-open	<i>Bi</i> [mm]	<i>Ba</i> [mm]	<i>R</i> Bending radii [mm]	Pitch [mm]	Weight [kg/m]
333.16. <i>R/R.0</i>	-	16	26	038   048   075   100	13,3	0,33
333.32. <i>R/R.0</i>	-	32	50	075   100   125   150   200   250	25	0,90
333.50. <i>R/R.0</i>	353.50. <i>R/R.0</i>	50	68	100   125   150   200   250	30	1,40
333.75. <i>R/R.0</i>	-	75	96	140   175   200   250   300	36	2,35

The bending radii are doubled in the case of the Series 333 !

Supplement Part No. with required radius (*R*) Example: 333.75.200/200.0

Dimensions

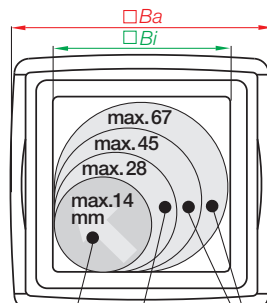
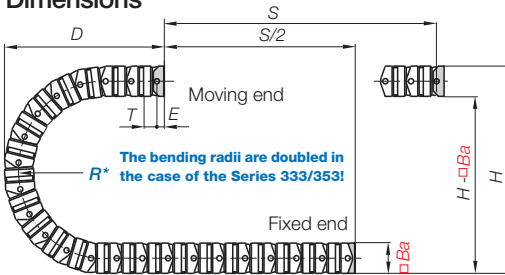

333.16 | 333.32 | 333./353.50 | 333.75

333.16.	<i>R</i>	038	048	075	100		
	<i>H</i>	180	220	330	430		
	<i>D</i>	105	125	180	230		
333.32.	<i>R</i>	075	100	125	150	200	250
	<i>H</i>	350	450	550	650	850	1050
	<i>D</i>	205	255	305	355	455	555
333.50./353.50.	<i>R</i>	100	125	150	200	250	
	<i>H</i>	470	570	670	870	1070	
	<i>D</i>	295	345	395	495	595	
333.75.	<i>R</i>	140	175	200	250	300	
	<i>H</i>	660	800	900	1100	1300	
	<i>D</i>	380	450	500	600	700	
333.75.	<i>K</i>	990	1210	1400	1700	2000	

Series E333.16.

<i>Ba</i>	26 mm
Pitch <i>T</i>	13,3 mm/link
Links/m	76 (1011 mm)
Dim. <i>E</i>	10 mm
Chain length	$S/2 + K$

Series E333.32.

<i>Ba</i>	50 mm
Pitch <i>T</i>	25 mm/link
Links/m	40 (1000 mm)
Dim. <i>E</i>	20 mm
Chain length	$S/2 + K$

Series 333.50./353.50.

<i>Ba</i>	68 mm
Pitch <i>T</i>	30 mm/link
Links/m	34 (1020 mm)
Dim. <i>E</i>	25 mm
Chain length	$S/2 + K$

Series E333.75.

<i>Ba</i>	96 mm
Pitch <i>T</i>	36 mm/link
Links/m	28 (1008 mm)
Dim. <i>E</i>	25 mm
Chain length	$S/2 + K$

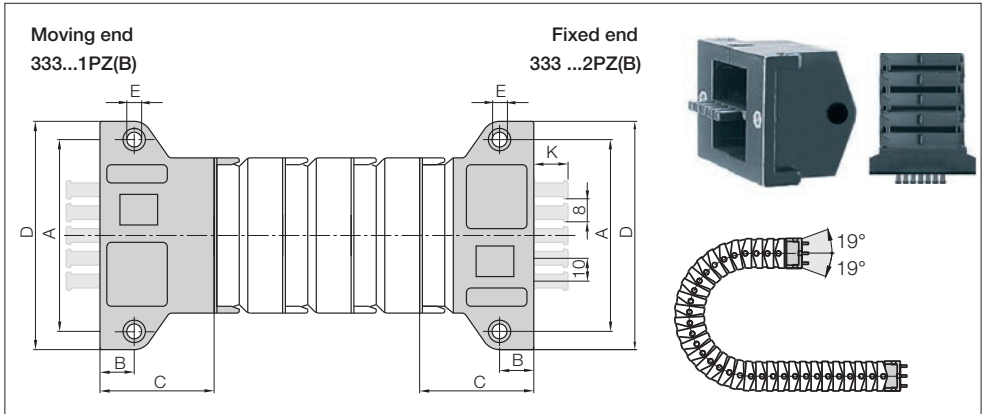

**KMA, one side pivoting**

Width Index	Part No. full set with tiewrap plates	Part No. full set without tiewrap plates	Dim A [mm]	Dim B [mm]	Dim C [mm]	Dim D [mm]	Dim E [mm]	Dim K [mm]	Number of teeth
32. ▶	333.32.12PZB	333.32.12PZ	66	15	46	82	6,5	15	3
50. ▶	333.50.12PZB	333.50.12PZ	84	15	50	100	6,5	15	5
75. ▶	333.75.12PZB	333.75.12PZ	109	15	55	125	6,5	15	7

(KMA = Polymer Metal Mounting Bracket)

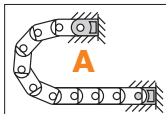

These attachment types are set automatically in the choice of the KMA mounting bracket. For the **preassembled** mode please add index **A**.

**Part No. structure**

**333.75. 12 PZBA**

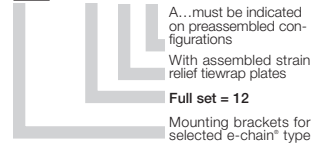

**Strain relief** e.g. clamps, tiewrap plates, nuggets and plug-in clips are available from stock. The complete chainfix range with order options ▶ from page 630



triflex® | Series 332·333·352·353 | Accessories

Mounting brackets, flange steel | pivoting

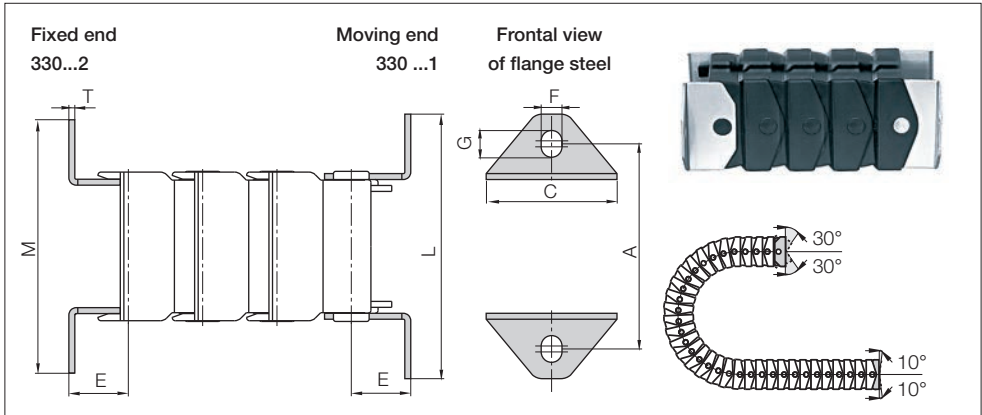

Flange steel, pivoting

Width Index	Part No. full set	Dim A [mm]	Dim M [mm]	Dim C [mm]	Dim L [mm]	Dim T [mm]	Dim E [mm]	Dim F [mm]	Dim G [mm]
16. ▶	330.16.12	35	53	21	57	1	10	4,5	6
32. ▶	330.32.12	66	84	44	88	2	20	7	9
50. ▶	330.50.12	84	102	62	106	2	25	7	9
75. ▶	330.75.12	109	127	90	131	2	25	7	9

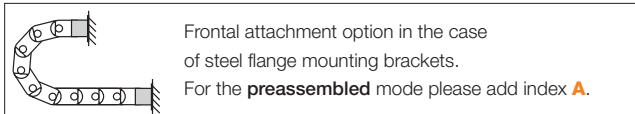

Part No. structure

330. 75. 12 **A**

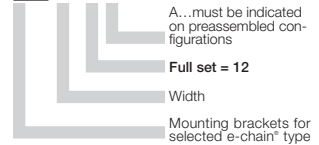

 **Strain relief** e.g. clamps, tiewrap plates, nuggets and plug-in clips are available from stock. The complete chainfix range with order options ▶ from page 630

# triflex® | Series 332·333·352·353 | Accessories

## Mounting brackets, angled, steel | pivoting

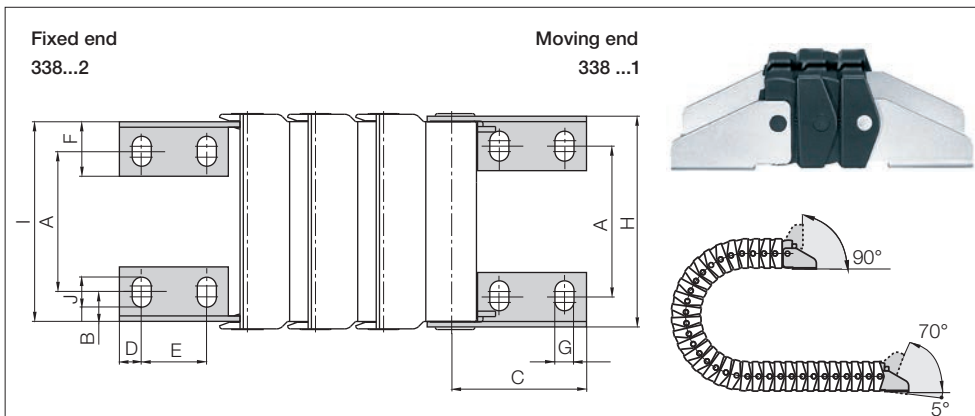

### Angled steel bracket | pivoting

Width Index	Part No. full set	Dim A [mm]	Dim B [mm]	Dim C [mm]	Dim D [mm]	Dim E [mm]	Dim F [mm]	Dim G [mm]	Dim H [mm]	Dim I [mm]	Dim J [mm]
16. ▶	<b>338.16.12</b>	12	3	25	5	10	11	4,5	25	23	6
32. ▶	<b>338.32.12</b>	24	5,5	47	8	24	20	7	49	45	11
50. ▶	<b>338.50.12</b>	42	5,5	77	12	35	24	9	67	62	15
75. ▶	<b>338.75.12</b>	65	5,5	77	12	35	24	9	95	90	15

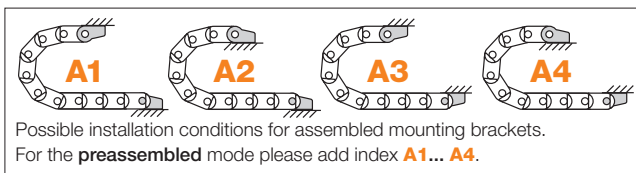

#### Part No. structure

**338. 75. 12 A**

A...must be indicated on preassembled configurations

Full set = 12

Width

Mounting brackets for selected e-chain\* type



**Strain relief** e.g. clamps, tie-wrap plates, nuggets and plug-in clips are available from stock. The complete chainfix range with order options ▶ from page 630

Interior separation

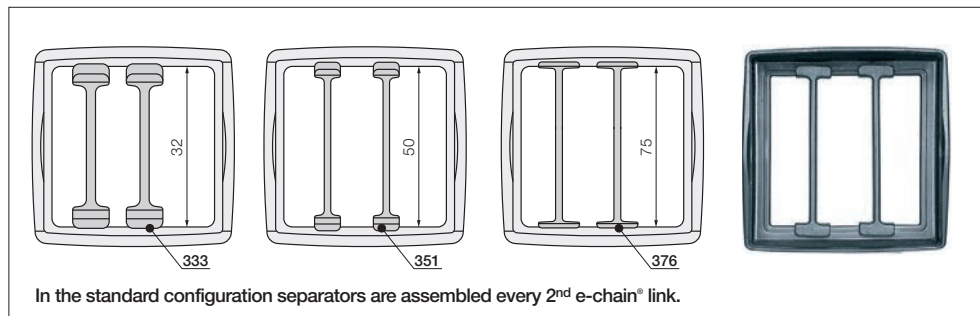

		<p><b>332.32/333.32</b></p> <p>unassembled <b>332</b> assembled <b>333</b></p>
		<p><b>352.50/353.50/</b> <b>352.50/353.50</b></p> <p>unassembled <b>350</b> assembled <b>351</b></p>
		<p><b>332.75/333.75</b></p> <p>unassembled <b>375</b> assembled <b>376</b></p>

Vertical Separators

Modular separators are available as interior separation for the igus® triflex® System. They can be used for both vertical and horizontal subdivision. If the separators are assembled every other link and turned 90°, the e-tube can be subdivided into four segments. We recommend ordering the e-tube preassembled, as subsequent assembly of separators is only possible after dismantling the e-tube. Please note that assembled separators have a different part number than unassembled separators.

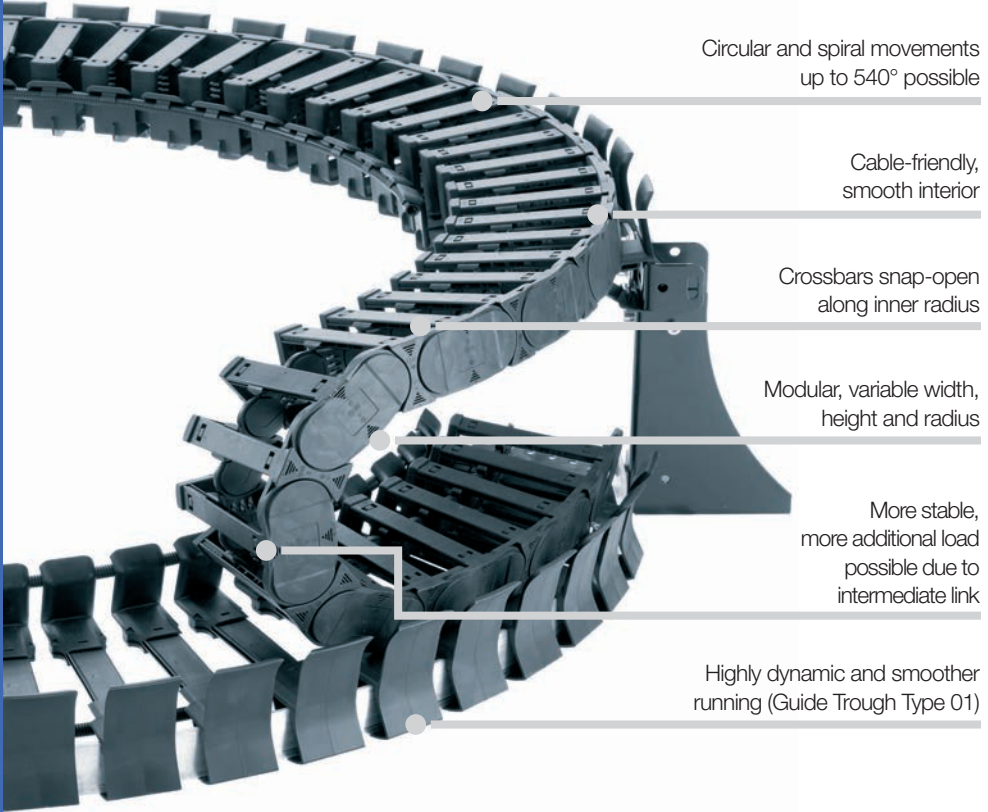

Circular and spiral movements  
up to 540° possible

Cable-friendly,  
smooth interior

Crossbars snap-open  
along inner radius

Modular, variable width,  
height and radius

More stable,  
more additional load  
possible due to  
intermediate link

Highly dynamic and smoother  
running (Guide Trough Type 01)

## New generation - twisterchain® new: robust, low-noise, for high loads

**Higher loads and smoother running** - igus® new generation of twisterchain® new circular e-chains® significantly improved smoothness, stability and strength. The twisterchain® new has a modular construction for width, height and radius and therefore provides very flexible use in applications where rotating movements up to 540° are required.

- Sturdier through intermediate link - more additional load possible
- 25% less weight than existing twisterchain®
- Rotary speeds up to 1 m/s and more, rotary/spiral movements up to 540°
- Highly dynamic and smoother running (with the guide trough Type 01)
- Cable-friendly, smooth interior
- Crossbars snap-open along inner radius
- Over 1 million cycles tested successfully in the igus® laboratory (03/2010)

### Typical industries and applications

- Robots, handling machines ● Packaging machines ● Glass machines ● General mechanical engineering



Circular movements up to 540° possible  
(with special attachments)



UL94-V0 classifications  
upon request



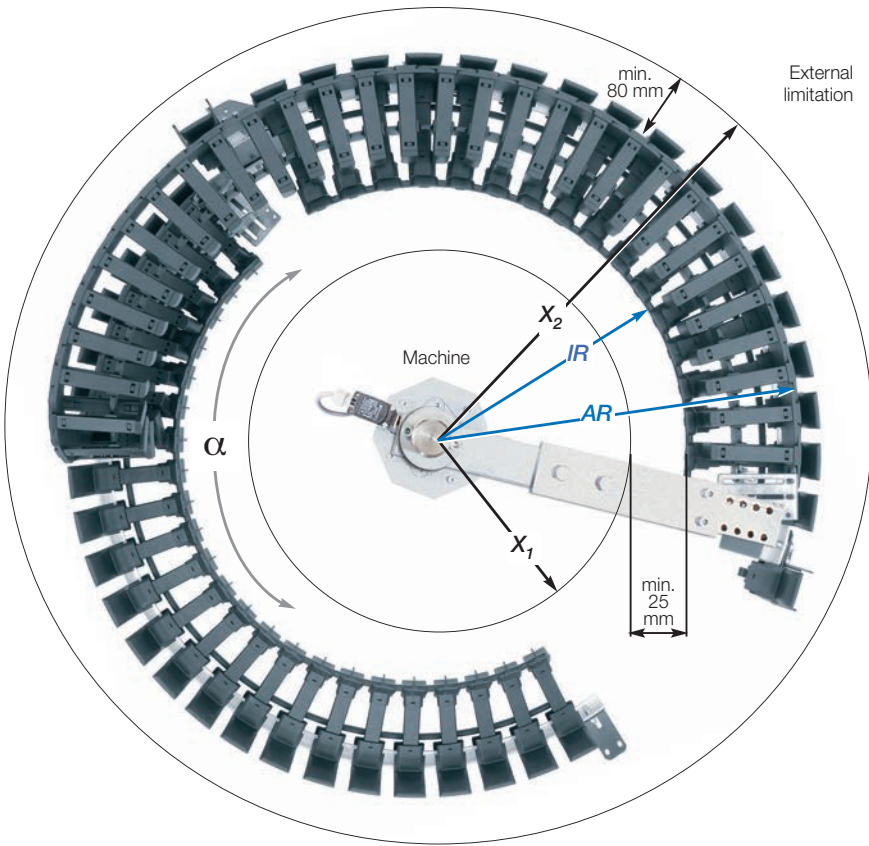

**twisterchain® definition**

In the case of machine elements which both move to the left and to the right following a circular path, the rotation angle can be determined by adding the two angles!

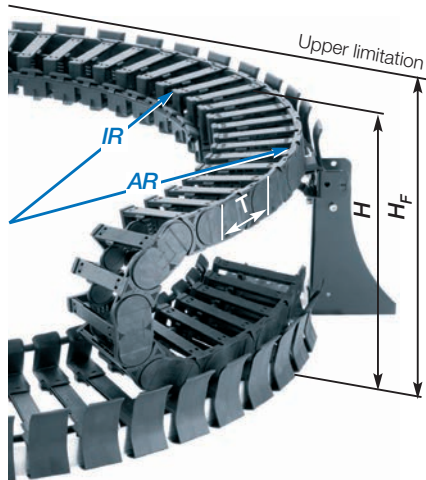
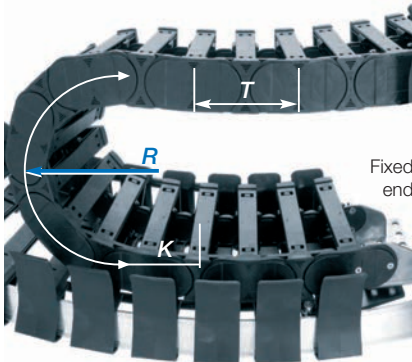

**AR** = Outer radius, e-chain\*  
**IR** = Inner radius, e-chain\*  
**R** = Bending radius

**X<sub>1</sub>** = Inner machine construction space  
**X<sub>2</sub>** = Outer radius **AR**, incl. clearance  
**T** = Pitch

**H<sub>F</sub>** = Height incl. 50 mm clearance  
**H** = Nominal clearance height  
**K** = Add-on for bending radius

**hi** = Inner height e-chain\*  
**ha** = Outer height e-chain\*  
**α** = Rotation angle

Series	Inner height <i>hi</i> [mm]	Inner width <i>Bi</i> [mm]	Outer width <i>Ba</i> [mm]	Outer height [mm]	Bending Radii <i>R</i> [mm]	Circular radii <i>AR</i> [mm]	Page
TC32	32	87,5 - 150	108,5 - 171	54	100 - 250	400 - 600	598
TC42	42	87,5 - 200	110,5 - 223	64	100 - 250	400 - 850	600
TC56	56	125 - 200	155 - 230	84	150 - 400	650 - 850	602



**twisterchain® new**  
for circular movements up to 540°, crossbars snap-open along inner radius

## Quickly generate complete twisterchain® models with guide trough and accessories

► [www.igus-cad.com](http://www.igus-cad.com)

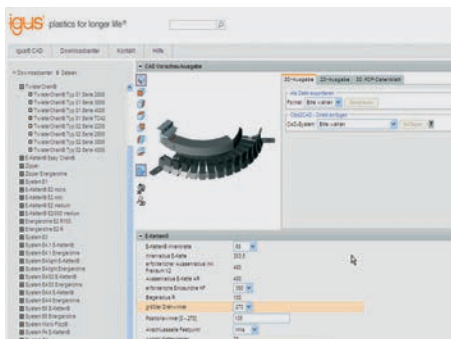

- Preparing of 3D-models only with input of chosen e-chain® radii and installation area
- Free positioning of the e-chain® moving end along the travel lengths
- Generation of twisterchain® optionally as single part or with guide trough and base support
- Fast download of the CAD files without registration
- CAD models in 11 different 3D CAD formats and 8 different 2D CAD formats

Technical Data

	Speed / acceleration	upon request
	Material - permitted temperature °C, igumid G / GLW	-40° up to +100°C
	Flammability class, igumid G / GLW	VDE 0304 IIC UL94-HB

Order example | Order key and color options based on Series TC56

 Order example for complete e-chain® (1,0 m), color black, with mounting brackets:

e-chain® (1,0 m)	Please indicate e-chain® length or number of links: 1,0 m or 11 links	<b>TC56.12.250/650.0</b>
+ Mounting brackets	1 set	<b>TC5600.34.VS.E</b>
Order text: 1,0 m TC32.12.250/650.0 + TC5600.34.VS.E		

 Order key **TC56.12.250/650.0**

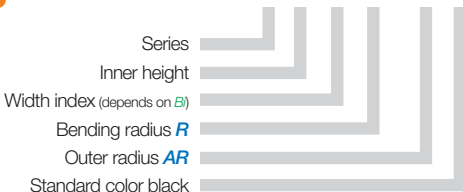

- Series
- Inner height
- Width index (depends on B)
- Bending radius **R**
- Outer radius **AR**
- Standard color black

**TC56.12.250/650.0** = e-chain® snap-open along inner radius from both sides  
**Bi 125** mm inner width, **R 250** mm bending radius / **AR 650** mm outer radius, color black

## Series TC32 | Snap-open along inner radius from both sides

AR [mm]	Bi [mm]	Ba [mm]	X <sub>2</sub> [mm]	X <sub>1</sub> [mm]	R 100 [mm] TC32...	R 125 [mm] TC32...	R 150 [mm] TC32...	R 175 [mm] TC32...	R 200 [mm] TC32...	R 250 [mm] TC32...	Weight [kg/m]
400	87,5	108,5	480	270	087.100/400	087.125/400	087.150/400	087.175/400	087.200/400	087.250/400	≈ 1,82
400	100	121	480	250	–	–	10. 150/400	10. 175/400	10. 200/400	10. 250/400	≈ 1,90
400	108	129	480	250	–	–	–	11. 175/400	11. 200/400	11. 250/400	≈ 1,95
400	125	146	480	220	–	–	–	12. 175/400	12. 200/400	12. 250/400	≈ 2,05
400	137,5	158,5	480	210	–	–	–	–	–	137.250/400	≈ 2,13
400	150	171	480	200	–	–	–	–	–	15. 250/400	≈ 2,21
500	100	121	580	350	10. 100/500	10. 125/500	10. 150/500	10. 175/500	10. 200/500	10. 250/500	≈ 1,90
500	108	129	580	350	–	11. 125/500	11. 150/500	11. 175/500	11. 200/500	11. 250/500	≈ 1,95
500	125	146	580	320	–	12. 125/500	12. 150/500	12. 175/500	12. 200/500	12. 250/500	≈ 2,05
500	137,5	158,5	580	310	–	–	137.150/500	137.175/500	137.200/500	137.250/500	≈ 2,13
500	150	171	580	300	–	–	15. 150/500	15. 175/500	15. 200/500	15. 250/500	≈ 2,21
600	108	129	680	450	11. 100/600	11. 125/600	11. 150/600	–	–	–	≈ 1,95
600	125	146	680	420	–	12. 125/600	12. 150/600	12. 175/600	12. 200/600	12. 250/600	≈ 2,05
600	137,5	158,5	680	410	–	137.125/600	137.150/600	137.175/600	137.200/600	137.250/600	≈ 2,13
600	150	171	680	400	–	–	15. 150/600	15. 175/600	15. 200/600	15. 250/600	≈ 2,21

R	100	125	150	175	200	250
H + <sup>0</sup>	254	304	354	404	454	554
K	465	550	620	700	780	940

Pitch *T* = 56 mm/link  
 Links/m = 18 (1008 mm)



**Dimension A1** depending on outer radius *AR*

<b>AR</b> [mm]	<i>R</i> 100 <b>A1</b> [mm]	<i>R</i> 125 <b>A1</b> [mm]	<i>R</i> 150 <b>A1</b> [mm]	<i>R</i> 175 <b>A1</b> [mm]	<i>R</i> 200 <b>A1</b> [mm]	<i>R</i> 250 <b>A1</b> [mm]
<b>400</b>	51	51	52	53	53	58
<b>500</b>	65	65	66	67	69	71
<b>600</b>	79	80	81	81	82	85

Dimension A1 always with tolerance of ±2,5 mm

**Dimensioning**

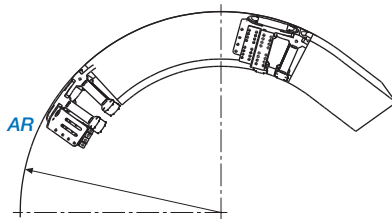
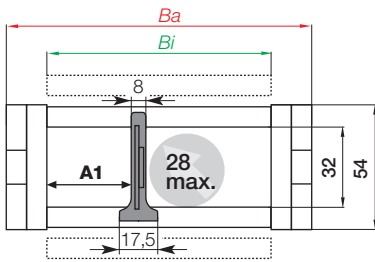

**Note:** Outer radius *AR* (see drawing) determines **dimension A1!**

twisterchain® new | Series TC32 | Interior separation

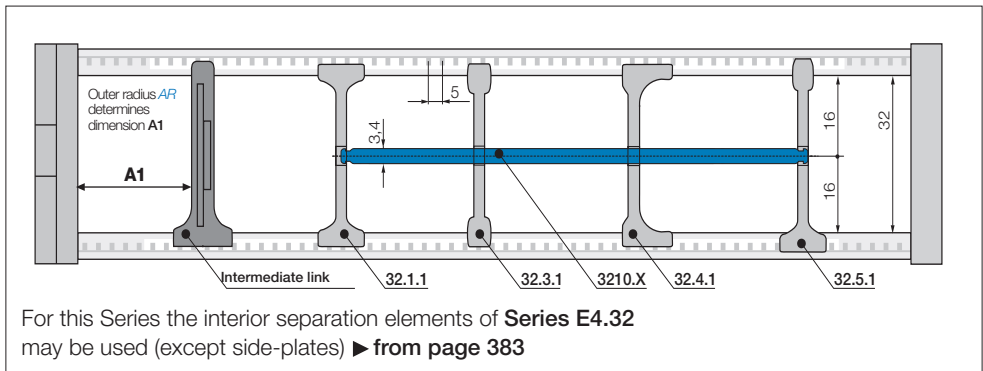

For this Series the interior separation elements of **Series E4.32** may be used (except side-plates) ▶ **from page 383**

- i** *AR* = Outer radius    *X*<sub>1</sub> = Inner machine construction space    *Ba* = Outer width    *H* = Nominal clearance height    *A1* = Distance intermediate link
- R* = Bending radius    *X*<sub>2</sub> = Outer radius *AR*, incl. clearance    *Bi* = Inner width    *K* = Add-on for bending radius    *T* = Pitch

Circular and spiral movements up to 540° possible

## Series TC42 | Snap-open along inner radius from both sides

AR [mm]	Bi [mm]	Ba [mm]	X <sub>2</sub> [mm]	X <sub>1</sub> [mm]	R 100 [mm] TC42...	R 125 [mm] TC42...	R 150 [mm] TC42...	R 175 [mm] TC42...	R 200 [mm] TC42...	R 250 [mm] TC42...	Weight [kg/m]
400	87,5	110,5	480	270	087.100/400	087.125/400	087.150/400	087.175/400	087.200/400	087.250/400	≈ 1,97
400	100	123	480	250	10. 100/400	10. 125/400	10. 150/400	10. 175/400	10. 200/400	10. 250/400	≈ 2,03
400	108	131	480	250	–	11. 125/400	11. 150/400	11. 175/400	11. 200/400	11. 250/400	≈ 2,07
400	125	148	480	220	–	12. 125/400	12. 150/400	12. 175/400	12. 200/400	12. 250/400	≈ 2,16
400	137,5	160,5	480	210	–	137.125/400	137.150/400	137.175/400	137.200/400	137.250/400	≈ 2,22
400	150	173	480	200	–	–	–	15. 175/400	15. 200/400	15. 250/400	≈ 2,29
400	162,5	185,5	480	190	–	–	–	–	162.200/400	162.250/400	≈ 2,35
400	168	191	480	190	–	–	–	–	–	17. 250/400	≈ 2,38
400	175	198	480	180	–	–	–	–	–	18. 250/400	≈ 2,41
500	100	123	580	350	10. 100/500	10. 125/500	10. 150/500	10. 175/500	10. 200/500	10. 250/500	≈ 2,03
500	108	131	580	350	–	11. 125/500	11. 150/500	11. 175/500	11. 200/500	11. 250/500	≈ 2,07
500	125	148	580	320	–	12. 125/500	12. 150/500	12. 175/500	12. 200/500	12. 250/500	≈ 2,16
500	137,5	160,5	580	310	–	–	137.150/500	137.175/500	137.200/500	137.250/500	≈ 2,22
500	150	173	580	300	–	–	15. 150/500	15. 175/500	15. 200/500	15. 250/500	≈ 2,29
500	162,5	185,5	580	290	–	–	162.150/500	162.175/500	162.200/500	162.250/500	≈ 2,35
500	168	191	580	290	–	–	–	17. 175/500	17. 200/500	17. 250/500	≈ 2,38
500	175	198	580	280	–	–	–	–	18. 200/500	18. 250/500	≈ 2,41
500	187,5	210,5	580	280	–	–	–	–	187.200/500	187.250/500	≈ 2,48
500	200	223	580	250	–	–	–	–	20. 200/500	20. 250/500	≈ 2,54
600	108	131	680	450	11. 100/600	11. 125/600	11. 150/600	11. 175/600	11. 200/600	–	≈ 2,07
600	125	148	680	420	12. 100/600	12. 125/600	12. 150/600	12. 175/600	12. 200/600	12. 250/600	≈ 2,16
600	137,5	160,5	680	410	137.100/600	137.125/600	137.150/600	137.175/600	137.200/600	137.250/600	≈ 2,22
600	150	173	680	400	15. 100/600	15. 125/600	15. 150/600	15. 175/600	15. 200/600	15. 250/600	≈ 2,29
600	162,5	185,5	680	390	–	162.125/600	162.150/600	162.175/600	162.200/600	162.250/600	≈ 2,35
600	168	191	680	390	–	–	17. 150/600	17. 175/600	17. 200/600	17. 250/600	≈ 2,38
600	175	198	680	380	–	–	18. 150/600	18. 175/600	18. 200/600	18. 250/600	≈ 2,41
600	187,5	210,5	680	380	–	–	187.150/600	187.175/600	187.200/600	187.250/600	≈ 2,48
600	200	223	680	350	–	–	20. 150/600	20. 175/600	20. 200/600	20. 250/600	≈ 2,54
650	125	148	730	470	12. 100/650	12. 125/650	12. 150/650	12. 175/650	12. 200/650	12. 250/650	≈ 2,16
650	137,5	160,5	730	460	137.100/650	137.125/650	137.150/650	137.175/650	137.200/650	137.250/650	≈ 2,22
650	150	173	730	450	15. 100/650	15. 125/650	15. 150/650	15. 175/650	15. 200/650	15. 250/650	≈ 2,29
650	162,5	185,5	730	440	–	162.125/650	162.150/650	162.175/650	162.200/650	162.250/650	≈ 2,35
650	168	191	730	430	–	17. 125/650	17. 150/650	17. 175/650	17. 200/650	17. 250/650	≈ 2,38
650	175	198	730	430	–	–	18. 150/650	18. 175/650	18. 200/650	18. 250/650	≈ 2,41
650	187,5	210,5	730	420	–	–	187.150/650	187.175/650	187.200/650	187.250/650	≈ 2,48
650	200	223	730	400	–	–	20. 150/650	20. 175/650	20. 200/650	20. 250/650	≈ 2,54
750	137,5	160,5	830	560	137.100/750	137.125/750	137.150/750	137.175/750	137.200/750	137.250/750	≈ 2,22
750	150	173	830	550	15. 100/750	15. 125/750	15. 150/750	15. 175/750	15. 200/750	15. 250/750	≈ 2,29
750	162,5	185,5	830	540	–	162.125/750	162.150/750	162.175/750	162.200/750	162.250/750	≈ 2,35
750	168	191	830	540	–	17. 125/750	17. 150/750	17. 175/750	17. 200/750	17. 250/750	≈ 2,38
750	175	198	830	530	–	18. 125/750	18. 150/750	18. 175/750	18. 200/750	18. 250/750	≈ 2,41
750	187,5	210,5	830	520	–	187.125/750	187.150/750	187.175/750	187.200/750	187.250/750	≈ 2,48
750	200	223	830	500	–	20. 125/750	20. 150/750	20. 175/750	20. 200/750	20. 250/750	≈ 2,54
850	150	173	930	650	15. 100/850	15. 125/850	15. 150/850	15. 175/850	15. 200/850	15. 250/850	≈ 2,29
850	162,5	185,5	930	640	162.100/850	162.125/850	162.150/850	162.175/850	162.200/850	162.250/850	≈ 2,35
850	168	191	930	630	17. 100/850	17. 125/850	17. 150/850	17. 175/850	17. 200/850	17. 250/850	≈ 2,38
850	175	198	930	630	–	18. 125/850	18. 150/850	18. 175/850	18. 200/850	18. 250/850	≈ 2,41
850	187,5	210,5	930	620	–	187.125/850	187.150/850	187.175/850	187.200/850	187.250/850	≈ 2,48
850	200	223	930	600	–	20. 125/850	20. 150/850	20. 175/850	20. 200/850	20. 250/850	≈ 2,54

R	100	125	150	175	200	250	Pitch T	= 67 mm/link
H <sub>+25</sub> <sup>-0</sup>	267	317	367	417	467	567	Links/m	= 15 (1005 mm)

K 500 650 725 800 875 1050

600 3D-CAD files, configurators, PDF ► [www.igus.eu/eu/TC42](http://www.igus.eu/eu/TC42)

**Dimension A1** depending on outer radius **AR**

<b>AR</b> [mm]	<b>R 100</b> <b>A1</b> [mm]	<b>R 125</b> <b>A1</b> [mm]	<b>R 150</b> <b>A1</b> [mm]	<b>R 175</b> <b>A1</b> [mm]	<b>R 200</b> <b>A1</b> [mm]	<b>R 250</b> <b>A1</b> [mm]
<b>400</b>	49	50	51	53	54	58
<b>500</b>	64	65	66	67	68	71
<b>600</b>	79	79	80	81	82	85
<b>650</b>	86	87	87	88	89	92
<b>750</b>	101	101	102	103	104	106
<b>850</b>	116	116	117	118	118	120

Dimension A1 always with tolerance of ±2,5 mm

**Dimensioning**

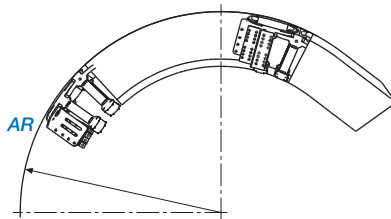
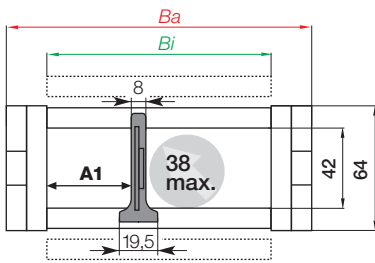

**Note:** Outer radius **AR** (see drawing) determines **dimension A1!**

twisterchain® new | Series TC42 | Interior separation

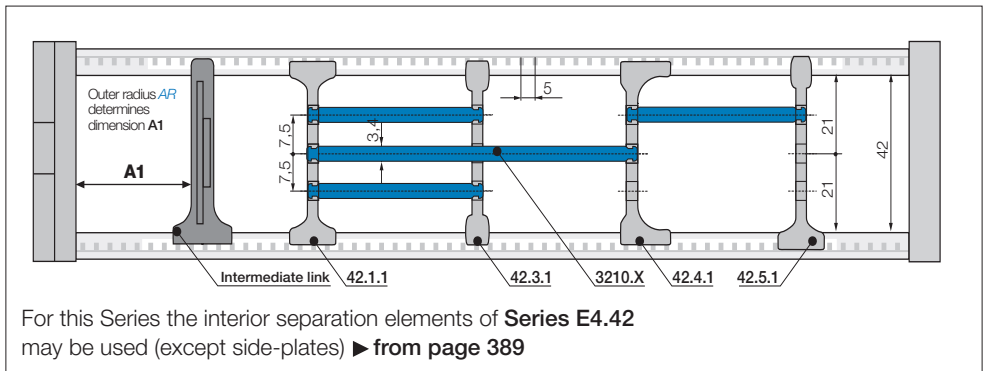

For this Series the interior separation elements of **Series E4.42** may be used (except side-plates) ▶ **from page 389**

- i** **AR** = Outer radius    **X<sub>1</sub>** = Inner machine construction space    **Ba** = Outer width    **H** = Nominal clearance height    **A1** = Distance intermediate link
- R** = Bending radius    **X<sub>2</sub>** = Outer radius **AR**, incl. clearance    **Bi** = Inner width    **K** = Add-on for bending radius    **T** = Pitch

Circular and spiral movements up to 540° possible

## Series TC56 | Snap-open along inner radius from both sides

AR [mm]	Bi [mm]	Ba [mm]	X <sub>2</sub> [mm]	X <sub>1</sub> [mm]	R 150 [mm] TC56...	R 200 [mm] TC56...	R 250 [mm] TC56...	R 300 [mm] TC56...	R 400 [mm] TC56...	Weight [kg/m]
650	125	155	730	470	12. 150/650	12. 200/650	12. 250/650	12. 300/650	–	≈ 3,45
650	137,5	168	730	460	–	13. 200/650	13. 250/650	13. 300/650	13. 400/650	≈ 3,54
650	150	180	730	450	–	–	15. 250/650	15. 300/650	15. 400/650	≈ 3,62
650	162,5	193	730	440	–	–	16. 250/650	16. 300/650	16. 400/650	≈ 3,7
650	175	205	730	430	–	–	–	17. 300/650	17. 400/650	≈ 3,78
650	187,5	218	730	420	–	–	–	18. 300/650	18. 400/650	≈ 3,87
650	200	230	730	400	–	–	–	–	20. 400/650	≈ 3,95
750	137,5	168	830	560	13. 150/750	13. 200/750	13. 250/750	13. 300/750	–	≈ 3,54
750	150	180	830	550	–	15. 200/750	15. 250/750	15. 300/750	15. 400/750	≈ 3,62
750	162,5	193	830	540	–	16. 200/750	16. 250/750	16. 300/750	16. 400/750	≈ 3,7
750	175	205	830	530	–	–	17. 250/750	17. 300/750	17. 400/750	≈ 3,78
750	187,5	218	830	520	–	–	18. 250/750	18. 300/750	18. 400/750	≈ 3,87
750	200	230	830	500	–	–	20. 250/750	20. 300/750	20. 400/750	≈ 3,95
850	150	180	930	650	15. 150/850	15. 200/850	15. 250/850	15. 300/850	15. 400/850	≈ 3,62
850	162,5	193	930	640	16. 150/850	16. 200/850	16. 250/850	16. 300/850	16. 400/850	≈ 3,7
850	175	205	930	630	17. 150/850	17. 200/850	17. 250/850	17. 300/850	17. 400/850	≈ 3,78
850	187,5	218	930	620	–	18. 200/850	18. 250/850	18. 300/850	18. 400/850	≈ 3,87
850	200	230	930	600	–	–	20. 250/850	20. 300/850	20. 400/850	≈ 3,95

R	150	200	250	300	400
H <sub>-0</sub> <sup>+25</sup>	384	484	584	684	884
K	750	900	1050	1225	1450

Pitch T = 91 mm/link  
Links/m = 11 (1001 mm)

**Dimension A1** depending on outer radius *AR*

<b>AR</b> [mm]	<i>R</i> 150 <b>A1</b> [mm]	<i>R</i> 200 <b>A1</b> [mm]	<i>R</i> 250 <b>A1</b> [mm]	<i>R</i> 300 <b>A1</b> [mm]	<i>R</i> 400 <b>A1</b> [mm]
<b>650</b>	83	85	88	90	97
<b>750</b>	98	101	102	103	110
<b>850</b>	113	116	117	118	124

Dimension A1 always with tolerance of ±2,5 mm

**Dimensioning**

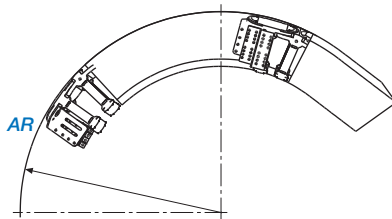
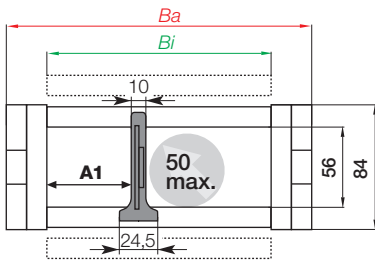

**Note:** Outer radius *AR* (see drawing) determines **dimension A1!**

twisterchain® new | Series TC56 | Interior separation

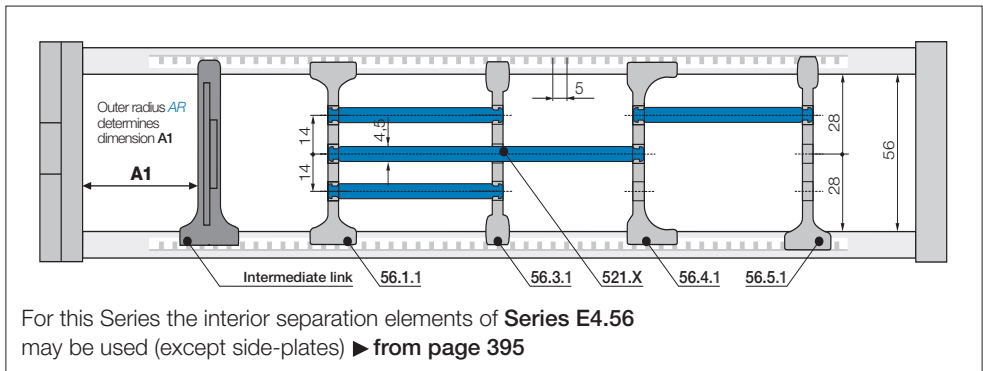

For this Series the interior separation elements of **Series E4.56** may be used (except side-plates) ► **from page 395**

- AR** = Outer radius    **X<sub>1</sub>** = Inner machine construction space    **Ba** = Outer width    **H** = Nominal clearance height    **A1** = Distance intermediate link
- R** = Bending radius    **X<sub>2</sub>** = Outer radius *AR*, incl. clearance    **Bi** = Inner width    **K** = Add-on for bending radius    **T** = Pitch

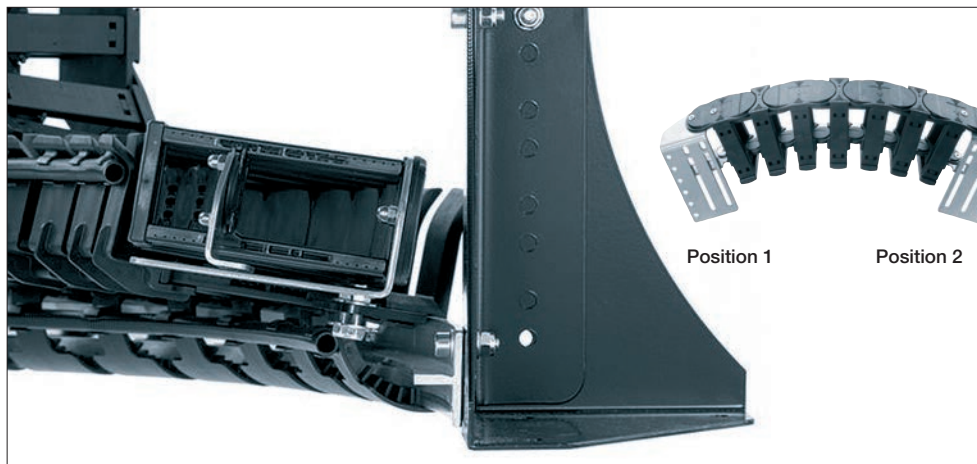

**Steel, one-piece | Recommended for unsupported and rotatory applications**

Für Series	Part No. full set	Part No. position 1	Part No. position 2
TC32 ▶	TC3200.34.VS.E	TC3200.30.VS.E	TC3200.40.VS.E
TC42 ▶	TC4200.34.VS.E	TC4200.30.VS.E	TC4200.40.VS.E
TC56 ▶	TC5600.34.VS.E	TC5600.30.VS.E	TC5600.40.VS.E

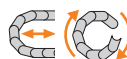

- One part for all e-chain® widths
- Electrically conductive
- Universal use
- Material: Stainless steel: 1.4301

The guide trough must be mounted at the fixed point of the twisterchain®.

The following bolted connections are permitted:

- Bore Hole: 4 x Ø 6,6 - 7 mm
- Mounting only with bolts: 4 x bolts M6

Other connection dimensions for mounting

**Part No. structure**

**TC3200.34.VS.E**

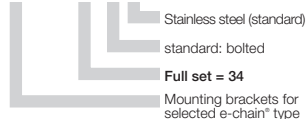

**Single-part order**

Position 1

**TC3200.30.VS.E**

Position 2

**TC3200.40.VS.E**

**Note:** twisterchain® e-chains® must always end with an outer side link. At the moving end an outer side link always forms the first e-chain® link. Please note when calculating!

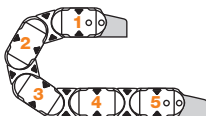

## New generation of twisterchain® guide troughs - Save assembly time and costs - increase cycle life!

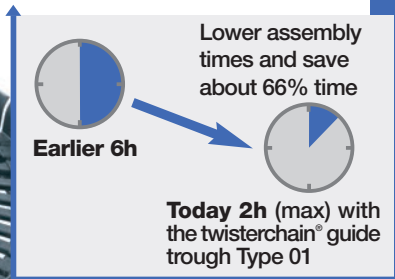
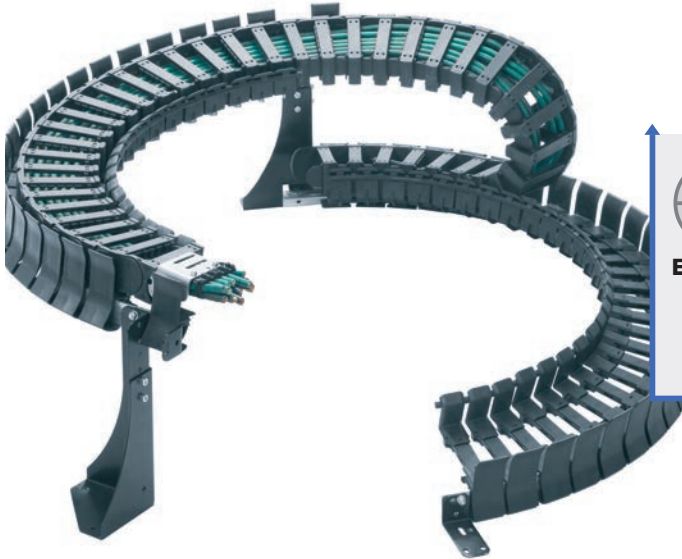

With the twisterchain® trough type 01, the previously complex adjustment work is clearly minimized. Assembly time is reduced from 6 h to 2 h. While reducing noise levels, travel speed and service life can be increased, thanks to an almost all-plastic design. Available for all twisterchain® of the new and previous range. Detailed information ► [www.igus.eu/TCtroughnew](http://www.igus.eu/TCtroughnew)

- Suitable for high dynamics, because of the full and all-side guidance of the twisterchain®
- Much smoother and quieter motion of the twisterchain® in the trough due to continuous guidance of upper run
- Upper run guided in the polymer trough over the full width
- Preassembled delivery possible
- Easy adjustment and alignment and handling
- Assembly time reduced from 6 hours to 2 hours

Upper run

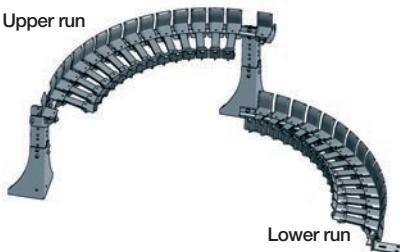

Lower run



Less parts, easier handling -  
Illustration shows a 180° application

Easy adjustment and alignment on the robot, predefined angles and predrilled mounting holes for height fixation

 Guide Trough Type 02 - continues to be available for special applications.  
Delivery program at ► [www.igus.eu/TCtroughclassic](http://www.igus.eu/TCtroughclassic)

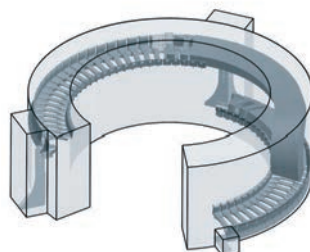
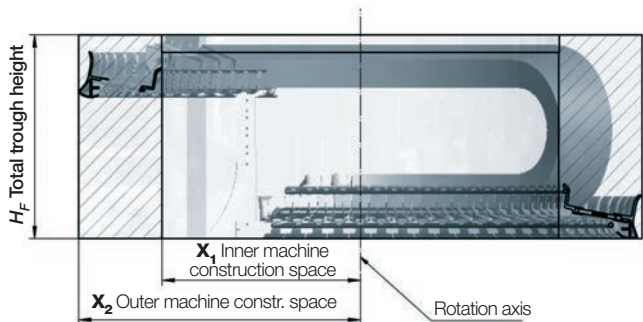

Min. required construction space of twisterchain®-Guide Trough system

Installation Dimensions |  $X_1$  inner machine construction space and  $X_2$  outer machine construction space of Guide Trough

$AR$ [mm]	$X_2$ [mm]	$X_1$ [mm] depending on $B_i$ [mm]													
<b>TC32</b>		87,5	100	108	125	137,5	150								
400	480	270	250	250	220	210	200								
500	580	-	350	350	320	310	300								
600	680	-	-	450	420	410	400								
<b>TC42</b>		87,5	100	108	125	137,5	150	162,5	168	175	187,5	200			
400	480	270	250	250	220	210	200	190	190	180	-	-			
500	580	-	350	350	320	310	300	290	290	280	280	250			
600	680	-	-	450	420	410	400	390	390	380	380	350			
650	730	-	-	-	470	460	450	440	440	430	420	400			
750	830	-	-	-	-	560	550	540	540	530	520	500			
850	930	-	-	-	-	-	650	640	640	630	620	600			
<b>TC56</b>					125	137,5	150	162,5	-	175	187	200			
650	730	-	-	-	470	460	450	440	-	430	420	400			
750	830	-	-	-	-	560	550	540	-	530	520	500			
850	930	-	-	-	-	-	650	640	-	630	620	600			
<b>2808</b>		50	68	75	87,5	100	108	125	137,5	150					
400	480	290	280	270	270	250	250	220	210	200					
500	580	390	380	370	370	350	350	320	310	300					
600	680	490	480	470	470	450	450	420	410	400					
<b>3808</b>		50	68	75	87,5	100	108	125	137,5	150	162,5	168	175	187,5	200
400	480	290	280	270	270	250	250	220	210	200	190	190	180	180	150
500	580	390	380	370	370	350	350	320	310	300	290	290	280	280	250
600	680	490	480	470	470	450	450	420	410	400	390	390	380	380	350
<b>4008</b>		50	65	75	100	112	125	137,5	150	162,5	175	187,5	200		
650	730	540	530	520	500	490	470	460	450	440	430	420	400		
750	830	640	630	620	600	590	570	560	550	540	530	520	500		



Guide troughs | Type 01 | Dimensions

Construction height |  $H_F$  depending on bending radius of twisterchain® Guide Trough

$R$ [mm]	100	125	150	175	200	250	300	400
Series	$H_F$ Construction height [mm]							
<b>TC32</b>	370	420	470	520	570	670	-	-
<b>TC42</b>	380	430	480	530	580	680	-	-
<b>TC56</b>	-	-	500	-	600	700	800	1000
<b>2808</b>	370	420	470	520	570	670	-	-
<b>3808</b>	380	430	480	-	580	680	-	-
<b>4008</b>	-	-	500	-	600	700	800	1000

Rotation angle for 360° |  $W_2$  angle of upper run [°] twisterchain® Guide Trough

$AR$ [mm]	Series	$R$ [mm]	100	125	150	175	200	250	300	400
$W_2$ Rotation angle [°]										
400	TC32/TC42/2808/3808	90°	90°	90°	90°	90°	90°	90°	90°	90°
500	TC32/TC42/2808/3808	90°	90°	90°	90°	90°	90°	90°	90°	90°
600	TC32/TC42/2808/3808	135°	135°	135°	135°	90°	90°	90°	90°	90°
650	TC42/TC56/4008	135°	135°	135°	135°	90°	90°	90°	90°	90°
750	TC42/TC56/4008	135°	135°	135°	135°	135°	135°	90°	90°	90°
850	TC42/TC56/4008	135°	135°	135°	135°	135°	135°	135°	135°	135°

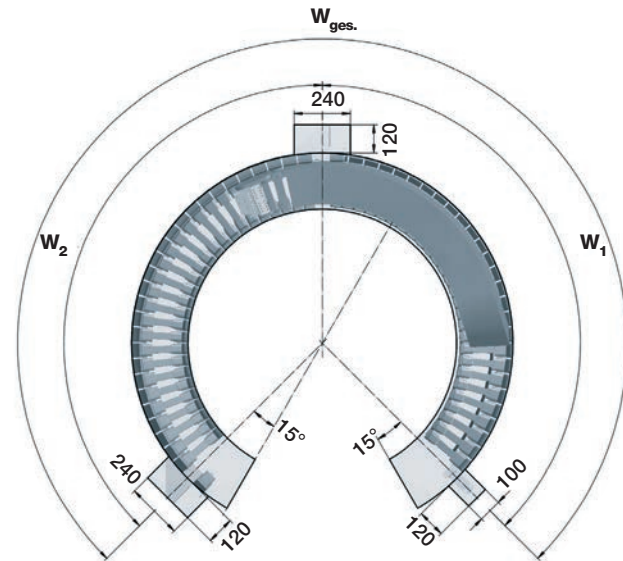

Rotation angle |  $W_1 + W_{ges.}$

$W_{ges.}$ rotation angle System [°]	$W_1$ rotation angle of lower run trough [°]
90°	45°
180°	90°
270°	135°
360°	180°



- $AR$  = Outer radius e-chain®
- $IR$  = Inner radius e-chain®
- $R$  = Bending radius
- $X_1$  = Inner machine construction space
- $X_2$  = Outer radius  $AR$ , incl. clearance
- $H_F$  = Total trough height
- $W_1$  = Angle of lower run
- $W_2$  = Angle of upper run
- $W_{ges.}$  = Rotation angle of system

twisterchain® Guide Trough options

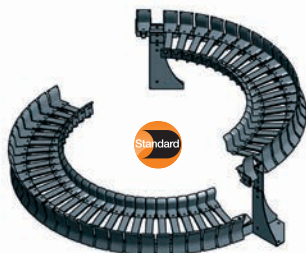

**9XXX.31**

**Complete troughs**

(with base support, height adjustment and attachment angles)



**9XXX.32**

**Upper and lower run trough**

(without base support and height adjustment)

Special variant: Customer builds base support



**9XXX.30**

**Lower run trough**

(with attachment angles)

Special variant: Customer builds upper run trough

Delivery program | twisterchain® Guide troughs Type 01

Part No. Series	Outer radius AR [mm]	Rotation angle from-up to α [°]	 Part No. complete trough	Part No. upper/lower run trough	Part No. lower run trough
TC32 / TC42 / 2808 / 3808	400	0 - 90°	9XXX.31.90 .400/Bi.R	9XXX.32.90 .400/Bi.R	9XXX.30.90 .400/Bi.R
		90° - 180°	9XXX.31.180.400/Bi.R	9XXX.32.180.400/Bi.R	9XXX.30.180.400/Bi.R
		180° - 270°	9XXX.31.270.400/Bi.R	9XXX.32.270.400/Bi.R	9XXX.30.270.400/Bi.R
		270° - 360°	9XXX.31.360.400/Bi.R	9XXX.32.360.400/Bi.R	9XXX.30.360.400/Bi.R
	500	0 - 90°	9XXX.31.90 .500/Bi.R	9XXX.32.90 .500/Bi.R	9XXX.30.90 .500/Bi.R
		90° - 180°	9XXX.31.180.500/Bi.R	9XXX.32.180.500/Bi.R	9XXX.30.180.500/Bi.R
		180° - 270°	9XXX.31.270.500/Bi.R	9XXX.32.270.500/Bi.R	9XXX.30.270.500/Bi.R
		270° - 360°	9XXX.31.360.500/Bi.R	9XXX.32.360.500/Bi.R	9XXX.30.360.500/Bi.R
	600	0 - 90°	9XXX.31.90 .600/Bi.R	9XXX.32.90 .600/Bi.R	9XXX.30.90 .600/Bi.R
		90° - 180°	9XXX.31.180.600/Bi.R	9XXX.32.180.600/Bi.R	9XXX.30.180.600/Bi.R
		180° - 270°	9XXX.31.270.600/Bi.R	9XXX.32.270.600/Bi.R	9XXX.30.270.600/Bi.R
		270° - 360°	9XXX.31.360.600/Bi.R	9XXX.32.360.600/Bi.R	9XXX.30.360.600/Bi.R
TC42 / TC56 / 4008	650	0 - 90°	9XXX.31.90 .650/Bi.R	9XXX.32.90 .650/Bi.R	9XXX.30.90 .650/Bi.R
		90° - 180°	9XXX.31.180.650/Bi.R	9XXX.32.180.650/Bi.R	9XXX.30.180.650/Bi.R
		180° - 270°	9XXX.31.270.650/Bi.R	9XXX.32.270.650/Bi.R	9XXX.30.270.650/Bi.R
	750	270° - 360°	9XXX.31.360.650/Bi.R	9XXX.32.360.650/Bi.R	9XXX.30.360.650/Bi.R
		0 - 90°	9XXX.31.90 .750/Bi.R	9XXX.32.90 .750/Bi.R	9XXX.30.90 .750/Bi.R
		90° - 180°	9XXX.31.180.750/Bi.R	9XXX.32.180.750/Bi.R	9XXX.30.180.750/Bi.R
	850	180° - 270°	9XXX.31.270.750/Bi.R	9XXX.32.270.750/Bi.R	9XXX.30.270.750/Bi.R
		270° - 360°	9XXX.31.360.750/Bi.R	9XXX.32.360.750/Bi.R	9XXX.30.360.750/Bi.R
		0 - 90°	9XXX.31.90 .850/Bi.R	9XXX.32.90 .850/Bi.R	9XXX.30.90 .850/Bi.R
	850	90° - 180°	9XXX.31.180.850/Bi.R	9XXX.32.180.850/Bi.R	9XXX.30.180.850/Bi.R
		180° - 270°	9XXX.31.270.850/Bi.R	9XXX.32.270.850/Bi.R	9XXX.30.270.850/Bi.R
		270° - 360°	9XXX.31.360.850/Bi.R	9XXX.32.360.850/Bi.R	9XXX.30.360.850/Bi.R

Supplement Part No. 9XXX with required Series (TC32, TC42, TC56, 2808, 3808, 4008), value Bi and required bending radius R ► 9XXX.31.180.600/06.250

9TC32.31.180.600/12.250



Order key  
Guide trough

9XXXX.31.180.600/Bi. R



R - Bending radius, please add appropriate value

Bi - Width index, please add appropriate value

Outer radius e-chain®

Rotation angle of application (90°, 180°, 270°, 360°)

Trough version

Guide Trough of selected Series

**More order examples**

- |   |   |
|---|---|
| ● Complete trough                                 | <b>Part No. 94008.31.180.600/12.250</b> |
| ● Lower run trough only                           | <b>Part No. 94008.30.180.600/12.250</b> |
| ● Upper and lower run trough without base support | <b>Part No. 94008.32.180.600/12.250</b> |



twisterchain® in a guide trough for rotary movements on an articulated robot - long service life and robust: more than 1.000.000 cycles tested successfully with prototype (issue 04/2009)

# twisterchain® classic | Introduction | Advantages

For new constructions we recommend: TC32, TC42, TC56 ► from page 598

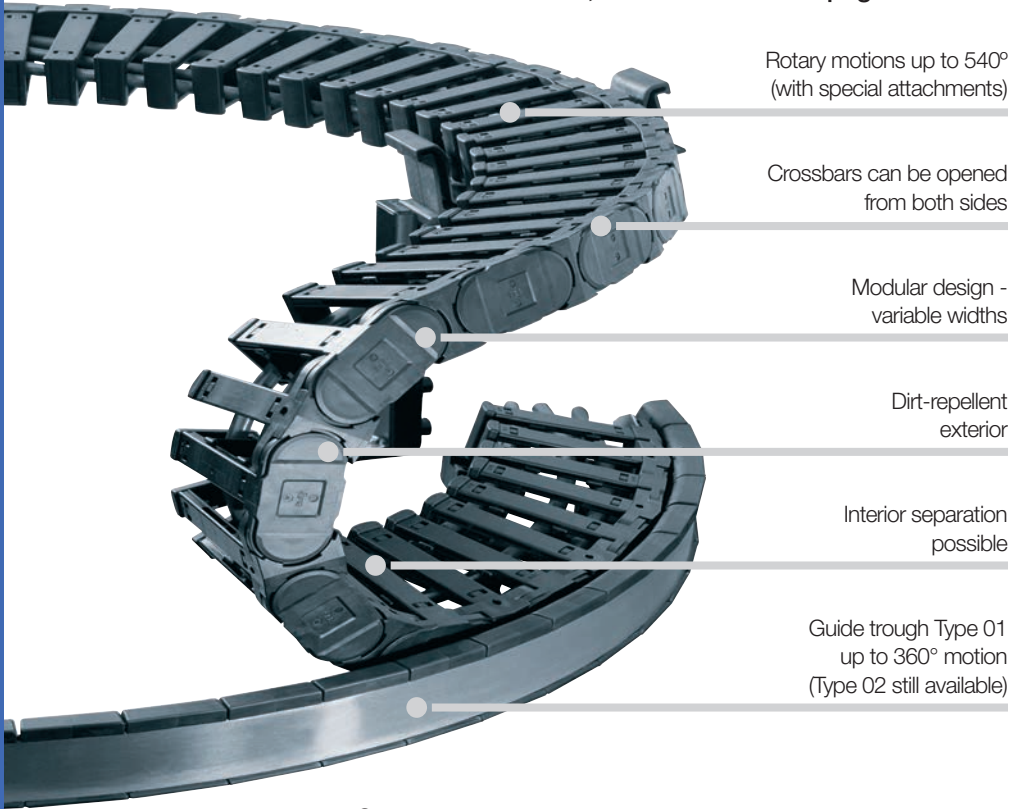

Rotary motions up to 540°  
(with special attachments)

Crossbars can be opened  
from both sides

Modular design -  
variable widths

Dirt-repellent  
exterior

Interior separation  
possible

Guide trough Type 01  
up to 360° motion  
(Type 02 still available)

## twisterchain® classic - Circular and spiral movements

The first generation of twisterchain® classic have proven themselves worldwide for years in many applications. They safely supply their robots in the rotary axis with energy and air. For new constructions we recommend twisterchain® new ► from page 594.

- Circular, spiral motions up to 540°
- Fast cable replacement - Crossbars snap open on both sides
- Modular, rugged design - variable widths
- Cable-friendly interior
- New guide troughs Type 01 and Type 02 (up to 360° motion) available from stock
- Variable interior separation
- Applicable in rotational speeds of up to 4 m/s
- With steel mounting brackets (electrically conductive)

### Typical industries and applications

- Robots ● Handling machines ● Packaging machines ● Glass machines



Circular movements up to 540° possible  
(with special attachments)



UL94-V0 classifications  
upon request



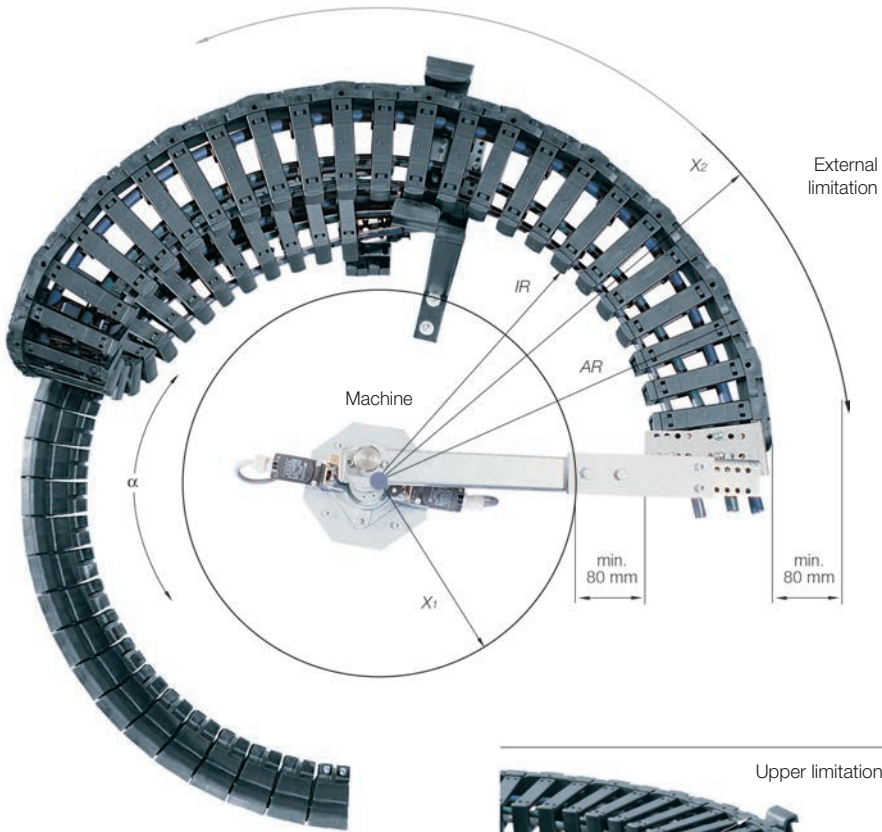

## twisterchain® definition

In the case of machine elements which both move to the left and to the right following a circular path, the rotation angle can be determined by adding the two angles!

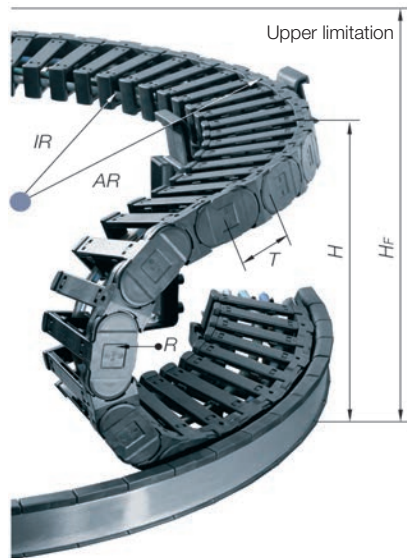
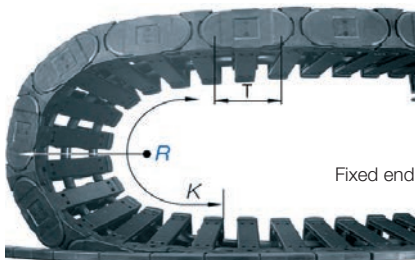

**AR** = Outer radius, e-chain\*  
**IR** = Inner radius, e-chain\*  
**R** = Bending radius

**X<sub>1</sub>** = Inner machine construction space  
**X<sub>2</sub>** = Outer radius **AR**, incl. clearance  
**T** = Pitch

**H<sub>f</sub>** = Height incl. 50 mm clearance  
**H** = Nominal clearance height  
**K** = Add-on for bending radius

**hi** = Inner height e-chain\*  
**ha** = Outer height e-chain\*  
**α** = Rotation angle

Series	Inner height <i>hi</i> [mm]	Inner width <i>Bi</i> [mm]	Outer width <i>Ba</i> [mm]	Outer height	Bending Radii <i>R</i> [mm]	Circular radii <i>AR</i> [mm]	Page
2208.	28	52,5 - 112,5	80 - 140	42	055 - 150	300	614
2808.*	32	50 - 150	81 - 181	54	100 - 250	400 - 600	616
3808.*	42	50 - 200	85 - 235	64	100 - 250	400 - 600	618
4008.*	56	50 - 200	93 - 243	84	150 - 400	650 - 850	620

\*new version available



**twisterchain® classic**  
for circular movements,  
can be opened from both sides

## Quickly generate complete twisterchain® models with guide trough and accessories

► [www.igus.eu/eu/twister-configurator](http://www.igus.eu/eu/twister-configurator)

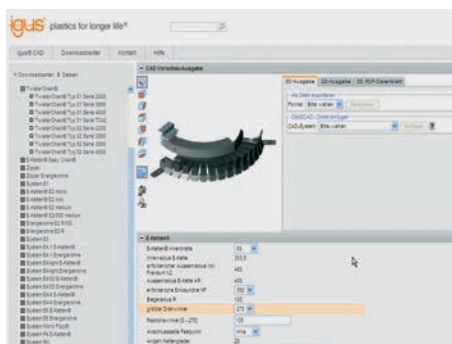

- Preparing of 3D-models only with input of chosen e-chain® radii and installation area
- Free positioning of the e-chain® moving end along the travel lengths
- Generation of twisterchain® optionally as single part or with guide trough and base support
- Fast download of the CAD files without registration
- CAD models in 11 different 3D CAD formats and 8 different 2D CAD formats

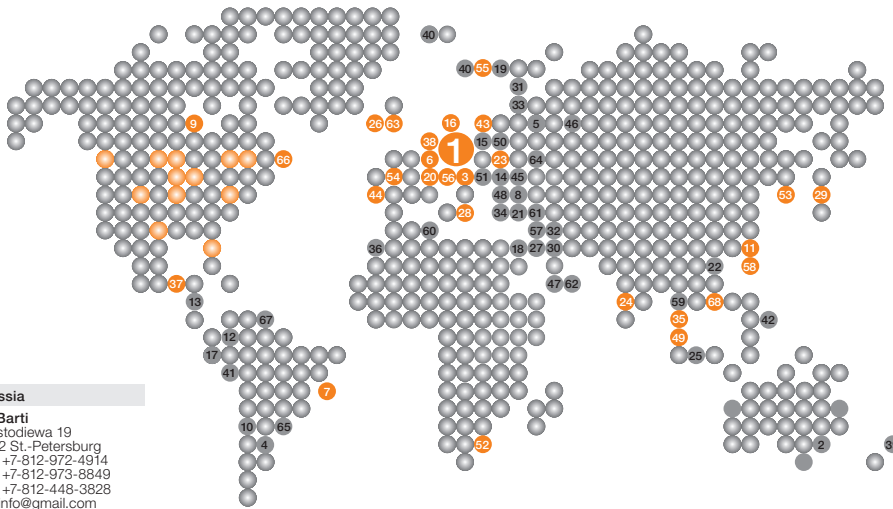

#### 46 Russia

##### OOO Barti

Ul. Kustodiewa 19  
194352 St.-Petersburg  
Phone +7-812-972-4914  
+7-812-973-8849  
Fax +7-812-448-3828  
bartix.info@gmail.com

#### 46 Russia

**OOO Eka-Service Kompani**  
1-aja Dubrowskaja, 2A, k. 35  
109044 Moskau  
Phone +7 495 6326623  
Fax +7 495 6771778  
zakaz@ekaservice.ru

#### 47 Saudi Arabia

##### AFI

Khalaf Bin Hesham Street  
Box 9998  
31423 Dammam  
Phone +966 38740033  
Fax +966 38470077  
marketing@afi.com.sa

#### 48 Serbia + Montenegro

##### Hennlich doo Beograd

Ul. S. Markovica 3/4  
11400 Mladenovac  
Mob.: +381 65 58 81 550  
Office: +381 64 18 81 549  
info@hennlich.rs

#### 49 Singapore - HQ ASEAN

##### igus® Singapore Pte Ltd.

15 Shaw Road, #03-02  
Singapore 367953  
Phone +65 64 87-1411  
Fax +65-64 87-1511  
Hotlines #:  
Malaysia +603 7880 5475  
Thailand +668 1902 1113  
Vietnam +84 90 929 4487  
Indonesia +62 812 986 11002  
asia-sale@igus.de

#### 50 Slovakia

##### Hennlich Industrietechnik s.r.o.

Miletčova 16  
SK-821 08 Bratislava  
Phone +421 2 50202504  
Fax +421 2 50202520  
technik@hennlich.sk

#### 51 Slovenia

##### Hennlich, d. o. o.

Industrijska tehnika  
Podnart 33  
SI-4244 Podnart  
Phone +386 4 53206-10  
Fax +386 4 53206-20  
info@hennlich.si

#### 52 South Africa

##### igus® Pty. Ltd.

Unit 29  
Midline Business Park  
Cnr Le Roux & Richards Drive  
Midrand 1682  
Phone +27 11312-1848  
Fax +27 11312-1594  
sales.sa@igus.de

#### 53 South Korea

##### igus® Korea Co. Ltd.

613-14 Namchondong,  
Namdonggu  
Incheon City, 405-300  
Phone +82 32 82129-11  
Fax +82 32 82129-13  
info@igus.kr

#### 54 Spain

##### igus® S.L.

C/ Llobatona, 6  
Polígono Noi del Sucre  
08840 Viladecans - BCN  
Phone +34 936 473950  
Fax +34 936 473951  
igus.es@igus.es

#### 55 Sweden

##### igus® ab

Knut Páls väg 8  
256 69 Helsingborg  
Phone +46 42 329270  
Fax +46 42 211585  
info@igusab.se

#### 55 Sweden - e-chains®

##### OEM Automatic AB

Box 1011 Dalagatan 4  
573 28 Tranås  
Phone +46 75 2424100  
Fax +46 75 2424159  
info@aut.oem.se

#### 55 Sweden - Bearings

##### Colly Components AB

P.O. Box 76  
164 94 Kista  
Phone +46 8 7030100  
Fax +46 8 7039841  
info@me.colly.se

#### 56 Switzerland

##### igus® Schweiz GmbH

Winkelstr. 5  
4622 Egerkingen  
Phone +41 62 3889797  
Fax +41 62 3889799  
info@igus.ch

#### 57 Syria

##### ETTA Systems

Al-Hamra St. Shalan Building  
12850 Damascus  
Phone +96 311 332 5519  
Fax: +96 311 334 2639  
info@ettasystems.com

#### 58 Taiwan

##### igus® Taiwan Company Ltd.

5F, No. 35, 24th Road  
Taichung Industrial Park  
Taichung 40850  
Phone +886 4 2358-1000  
Fax +886 4 2358-1100  
info@igus.com.tw

#### 59 Thailand

##### Autoflexible Advanced Engineering Co., Ltd.

111 Soi. Sukhumvit,  
62/1 Sukhumvit Rd,  
Bangjak, Phakanong,  
Bangkok 10260  
Phone +66 2 3112111  
Fax +66 2 3327900  
sales\_thailand@igus.com.sg

#### 60 Tunisia

##### BOUDRANT

53, Avenue de Carthage  
1000 Tunis - Tunisia  
Phone +216 71340244  
Fax +216 71348910  
info@boudrant.com.tn

#### 61 Turkey

##### HIDREL Hidrolik Elemanlar

Sanayi ve Ticaret Sk. No. 7  
Tünel Mevki  
34420 Karaköy / Istanbul  
Phone +90 212 2494881  
Fax +90 212 2920850  
info@hidrel.com.tr

#### 62 United Arab Emirates

##### Unigroup (FZE)

1st floor Rasana  
Building M602  
Sharjah Intern. Airport Freezone  
P.O. Box 120300  
Sharjah - UAE  
Phone +971 6 5578386  
Fax +971 6 5578387  
automation@unigroup.ae

#### 62 United Arab Emirates

##### Power & Technology Trading Co. L.L.C

P.O. Box 33372 SHJ  
Sharjah - UAE  
Phone +971 6 5421300  
Fax +971 6 5423700  
sales@powertech.ae

#### 63 United Kingdom

##### igus® UK Ltd.

51A Caswell Road  
Brackmills  
Northampton NN4 7PW  
Phone +44 1604 677240  
Fax e-chain®  
+44 1604 677242  
Fax Bearing  
+44 1604 677245  
sales@igus.co.uk

#### 64 Ukraine

##### Cominpro Ltd.

Romena Rollana 12,  
Office 220  
61058 Kharkov  
Phone +38 0577174914  
Fax +38 0577174914  
cominpro@gmail.com

#### 64 Ukraine

##### Hennlich Ukraine LLC (HQ)

Kramatorska Street 15  
84100 Sloviansk City,  
Donetsky Region  
Phone +38 06262 33540  
hennlich@hennlich.com.ua

#### 65 Uruguay

##### Larrique Rulemanas SA

Galicia 1204  
Montevideo-Uruguay  
P.O. Box 598 29021773  
Fax +598 29084824  
larrique@larrique.com.uy

#### 66 USA

##### igus® inc.

50 N. Broadway  
P.O. Box 14349  
East Providence, RI 02914  
Phone +1 401 4382200  
Fax +1 401 4387270  
webmaster@igus.com

#### 67 Venezuela

##### Neumatica Rotonda C.A.

Prolong Av. Michelen  
C.C. Atlas Locales B-10 y  
B-11  
Valencia, Edo. Carabobo  
Phone +58 241 832.64.64  
+58 241 832.32.50  
+58 241 838.85.19  
Fax +58 241 832.62.83  
ventas@neumaticar.com

#### 68 Vietnam

##### igus® Singapore Pte Ltd

The Representative Office  
in HoChiMinh City  
Office #03 Campus 06  
16/F Saigon Tower  
29 Le Duan Boulevard  
District 1  
Ho Chi Minh City, Vietnam  
Phone +84 909294487  
Fax +84 8 3520 7604  
sales\_vietnam@igus.com.sg

Technical Data

	Speed / acceleration	upon request
	Material - permitted temperature °C, igumid G / GLW	-40° up to +100° C
	Flammability class, igumid G / GLW	VDE 0304 IIC UL94-HB

Order example | Order key and color options based on Series 2208

 Order example for complete e-chain® (1,0 m), color black, with mounting brackets:

e-chain® (1,0 m)	Please indicate e-chain® length or number of links: 1,0 m or 22 links	2208.062.075/300.0
+ Mounting brackets	1 set	22080.34.VS.E

Order text: 1,0 m 2208.062.075/300.0 + 22080.34.VS.E

 Order key

**2208.062.075/300.0**

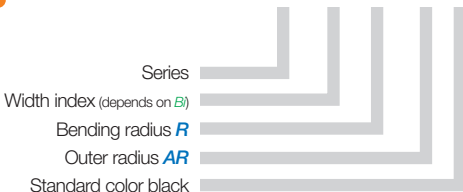

Series

Width index (depends on B)

Bending radius **R**

Outer radius **AR**

Standard color black

2208.062.075/300.0 = e-chain® snap-open along inner and outer radius  
**Bi 62,5** mm inner width, **R 075** mm bending radius / **AR 300** mm outer radius, color black



## Series 2208 | Snap-open along inner and outer radius

	<i>R</i> 055 [mm]	<i>R</i> 063 [mm]	<i>R</i> 075 [mm]	<i>R</i> 100 [mm]	<i>R</i> 125 [mm]	<i>R</i> 150 [mm]	<i>Bi</i> [mm]	<i>Ba</i> [mm]	<i>AR</i> [mm]	<i>IR</i> [mm]	Weight [kg/m]
2208...052055/300.0	.052.063/300.0	.052.075/300.0	.052.100/300.0	.052.125/300.0	.052.150/300.0	52,5	80	300	227	≈ 1,20	
2208...-	-	.062.075/300.0	.062.100/300.0	.062.125/300.0	.062.150/300.0	62,5	90	300	217	≈ 1,24	
2208...-	-	-	.074.100/300.0	.074.125/300.0	.074.150/300.0	74,5	102	300	205	≈ 1,29	
2208...-	-	-	.087.100/300.0	.087.125/300.0	.087.150/300.0	87,5	115	300	192	≈ 1,35	
2208...-	-	-	-	.112.125/300.0	.112.150/300.0	112,5	140	300	167	≈ 1,46	

<i>R</i>	055	063	075	100	125	150	Pitch <i>T</i>	= 44 mm/link
<i>K</i>	265	290	330	410	485	565	Links/m	= 23 (1012 mm)

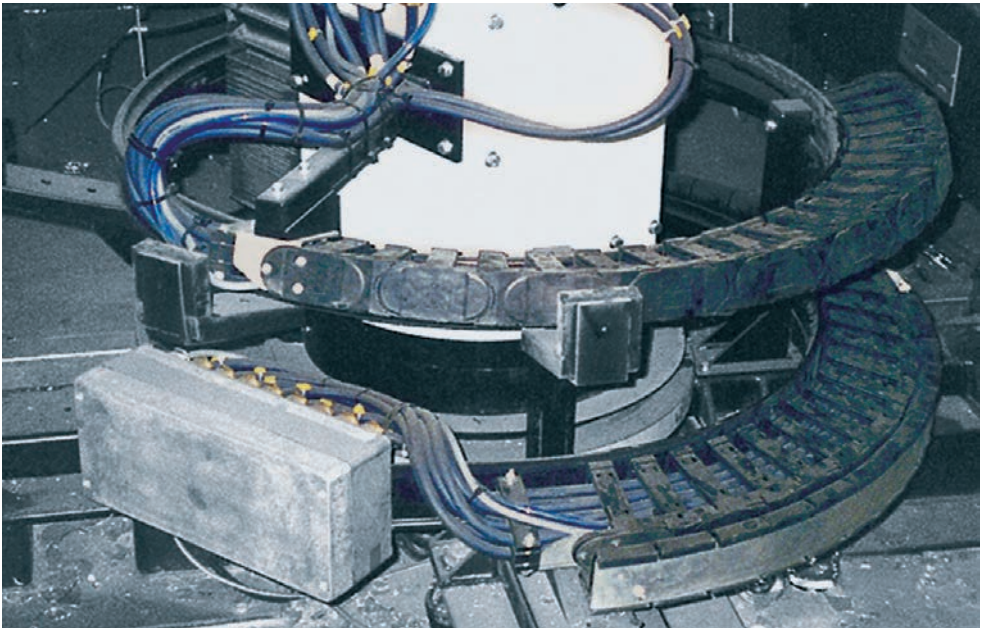

Combined spiral and rotary movement - igus® twisterchain® classic

Dimensioning

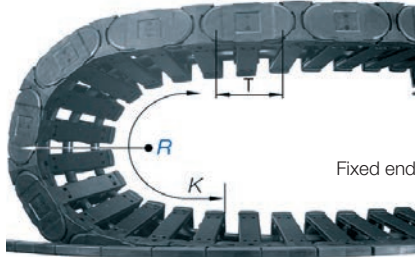
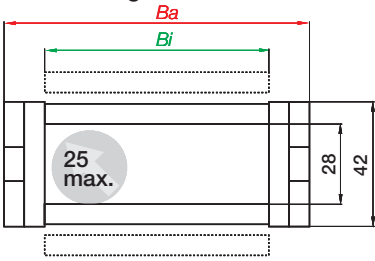

twisterchain® classic | Series 2208 | Interior separation

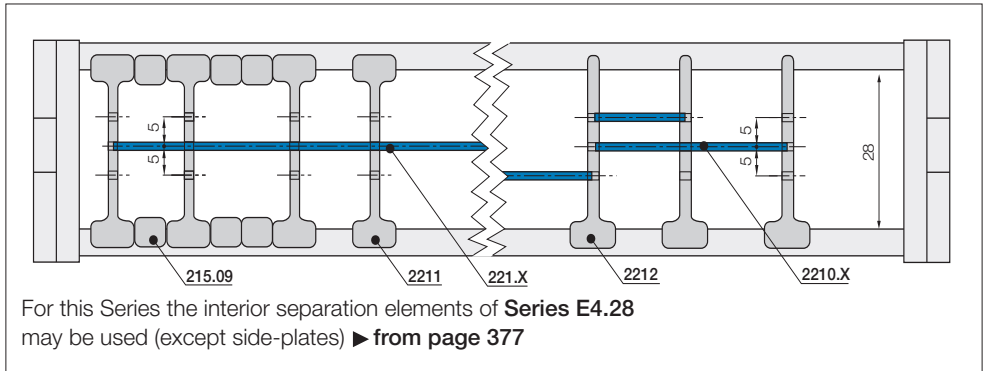

For this Series the interior separation elements of **Series E4.28** may be used (except side-plates) ▶ from page 377



$AR$  = Outer radius, e-chain\*     $Ba$  = Outer width, e-chain\*     $R$  = Bending radius, e-chain\*  
 $IR$  = Inner radius, e-chain\*     $Bi$  = Inner width, e-chain\*     $K$  = Add-on for bending radius

For new constructions we recommend: TC32 ▶ from page 598

## Series 2808 | Snap-open along inner and outer radius

	<b>R 100</b> [mm]	<b>R 125</b> [mm]	<b>R 150</b> [mm]	<b>R 175</b> [mm]	<b>R 200</b> [mm]	<b>R 250</b> [mm]	<b>Bi</b> [mm]	<b>Ba</b> [mm]	<b>AR</b> [mm]	<b>IR</b> [mm]	<b>Weight</b> [kg/m]
2808...05. 100/400.0	.05. 125/400.0	.05. 150/400.0	.05. 175/400.0	.05. 200/400.0	.05. 250/400.0	50	81	400	329,5	≈ 1,76	
2808...06. 100/400.0	.06. 125/400.0	.06. 150/400.0	.06. 175/400.0	.06. 200/400.0	.06. 250/400.0	68	99	400	311,5	≈ 1,87	
2808...07. 100/400.0	.07. 125/400.0	.07. 150/400.0	.07. 175/400.0	.07. 200/400.0	.07. 250/400.0	75	106	400	304,5	≈ 1,92	
2808...087100/400.0	.087125/400.0	.087150/400.0	.087175/400.0	.087200/400.0	.087250/400.0	87,5	118,5	400	292	≈ 1,99	
2808...-	-	.10. 150/400.0	.10. 175/400.0	.10. 200/400.0	.10. 250/400.0	100	131	400	279,5	≈ 2,07	
2808...-	-	-	.11. 175/400.0	.11. 200/400.0	.11. 250/400.0	108	139	400	271,5	≈ 2,12	
2808...-	-	-	.12. 175/400.0	.12. 200/400.0	.12. 250/400.0	125	156	400	254,5	≈ 2,22	
2808...-	-	-	-	-	.137250/400.0	137,5	168,5	400	242	≈ 2,30	
2808...-	-	-	-	-	.15. 250/400.0	150	181	400	229,5	≈ 2,38	
2808...05. 100/500.0	.05. 125/500.0	.05. 150/500.0	.05. 175/500.0	.05. 200/500.0	.05. 250/500.0	50	81	500	429,5	≈ 1,76	
2808...06. 100/500.0	.06. 125/500.0	.06. 150/500.0	.06. 175/500.0	.06. 200/500.0	.06. 250/500.0	68	99	500	411,5	≈ 1,87	
2808...07. 100/500.0	.07. 125/500.0	.07. 150/500.0	.07. 175/500.0	.07. 200/500.0	.07. 250/500.0	75	106	500	404,5	≈ 1,92	
2808...087100/500.0	.087125/500.0	.087150/500.0	.087175/500.0	.087200/500.0	.087250/500.0	87,5	118,5	500	392	≈ 1,99	
2808...10. 100/500.0	.10. 125/500.0	.10. 150/500.0	.10. 175/500.0	.10. 200/500.0	.10. 250/500.0	100	131	500	379,5	≈ 2,07	
2808...-	.11. 125/500.0	.11. 150/500.0	.11. 175/500.0	.11. 200/500.0	.11. 250/500.0	108	139	500	371,5	≈ 2,12	
2808...-	.12. 125/500.0	.12. 150/500.0	.12. 175/500.0	.12. 200/500.0	.12. 250/500.0	125	156	500	354,5	≈ 2,22	
2808...-	-	.137150/500.0	.137175/500.0	.137200/500.0	.137250/500.0	137,5	168,5	500	342	≈ 2,30	
2808...-	-	.15. 150/500.0	.15. 175/500.0	.15. 200/500.0	.15. 250/500.0	150	181	500	329,5	≈ 2,38	
2808...05. 100/600.0	.05. 125/600.0	.05. 150/600.0	.05. 175/600.0	.05. 200/600.0	.05. 250/600.0	50	81	600	529,5	≈ 1,76	
2808...06. 100/600.0	.06. 125/600.0	.06. 150/600.0	.06. 175/600.0	.06. 200/600.0	.06. 250/600.0	68	99	600	511,5	≈ 1,87	
2808...07. 100/600.0	.07. 125/600.0	.07. 150/600.0	.07. 175/600.0	.07. 200/600.0	.07. 250/600.0	75	106	600	504,5	≈ 1,92	
2808...087100/600.0	.087125/600.0	.087150/600.0	.087175/600.0	.087200/600.0	.087250/600.0	87,5	118,5	600	492	≈ 1,99	
2808...10. 100/600.0	.10. 125/600.0	.10. 150/600.0	.10. 175/600.0	.10. 200/600.0	.10. 250/600.0	100	131	600	479,5	≈ 2,07	
2808...11. 100/600.0	.11. 125/600.0	.11. 150/600.0	.11. 175/600.0	.11. 200/600.0	.11. 250/600.0	108	139	600	471,5	≈ 2,12	
2808...-	.12. 125/600.0	.12. 150/600.0	.12. 175/600.0	.12. 200/600.0	.12. 250/600.0	125	156	600	454,5	≈ 2,22	
2808...-	.137125/600.0	.137150/600.0	.137175/600.0	.137200/600.0	.137250/600.0	137,5	168,5	600	442	≈ 2,30	
2808...-	-	.15. 150/600.0	.15. 175/600.0	.15. 200/600.0	.15. 250/600.0	150	181	600	429,5	≈ 2,38	

<b>R</b>	<b>100</b>	<b>125</b>	<b>150</b>	<b>175</b>	<b>200</b>	<b>250</b>
<b>K</b>	465	550	620	700	780	940

**Pitch T** = 56 mm/link  
**Links/m** = 18 (1008 mm)

Dimensioning

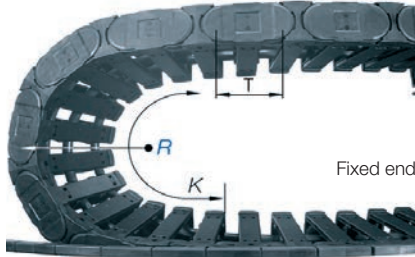
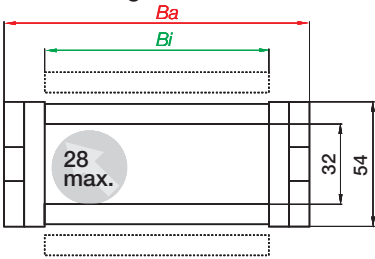

twisterchain® classic | Series 2808 | Interior separation

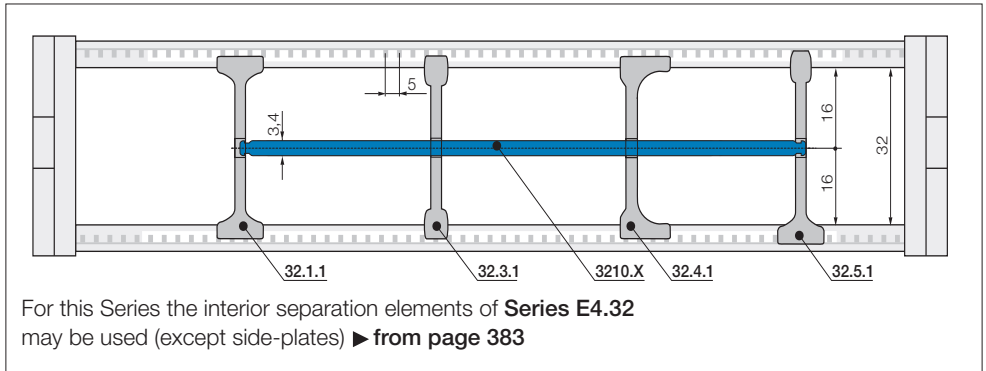

For this Series the interior separation elements of **Series E4.32** may be used (except side-plates) ▶ from page 383



$AR$  = Outer radius, e-chain\*     $Ba$  = Outer width, e-chain\*     $R$  = Bending radius, e-chain\*  
 $IR$  = Inner radius, e-chain\*     $Bi$  = Inner width, e-chain\*     $K$  = Add-on for bending radius

For new constructions we recommend: TC42 ▶ from page 600

## Series 3808 | Snap-open along inner and outer radius

	<b>R 100</b>	<b>R 125</b>	<b>R 150</b>	<b>R 200</b>	<b>R 250</b>	<b>Bi</b>	<b>Ba</b>	<b>AR</b>	<b>IR</b>	<b>Gewicht</b>
	[mm]	[mm]	[mm]	[mm]	[mm]	[mm]	[mm]	[mm]	[mm]	[kg/m]
3808... .05. 100/400.0 .05. 125/400.0 .05. 150/400.0 .05. 200/400.0 .05. 250/400.0	50	85	400	327,5	≈2,21					
3808... .06. 100/400.0 .06. 125/400.0 .06. 150/400.0 .06. 200/400.0 .06. 250/400.0	68	103	400	309,5	≈2,30					
3808... .07. 100/400.0 .07. 125/400.0 .07. 150/400.0 .07. 200/400.0 .07. 250/400.0	75	110	400	302,5	≈2,33					
3808... .087.100/400.0 .087.125/400.0 .087.150/400.0 .087.200/400.0 .087.250/400.0	87,5	122,5	400	290	≈2,40					
3808... .10. 100/400.0 .10. 125/400.0 .10. 150/400.0 .10. 200/400.0 .10. 250/400.0	100	135	400	277,5	≈2,46					
3808... – .11. 125/400.0 .11. 150/400.0 .11. 200/400.0 .11. 250/400.0	108	143	400	269,5	≈2,50					
3808... – .12. 125/400.0 .12. 150/400.0 .12. 200/400.0 .12. 250/400.0	125	160	400	252,5	≈2,59					
3808... – .137.125/400.0 .137.150/400.0 .137.200/400.0 .137.250/400.0	137,5	172,5	400	240	≈2,65					
3808... – – – .15. 200/400.0 .15. 250/400.0	150	185	400	227,5	≈2,72					
3808... – – – .162.200/400.0 .162.250/400.0	162,5	197,5	400	215	≈2,78					
3808... – – – .17. 250/400.0	168	203	400	209,5	≈2,81					
3808... – – – .18. 250/400.0	175	210	400	202,5	≈2,84					
3808... – – – – –	187,5	222,5	400	190	≈2,91					
3808... – – – – –	200	235	400	177,5	≈2,97					
3808... .05. 100/500.0 .05. 125/500.0 .05. 150/500.0 .05. 200/500.0 .05. 250/500.0	50	85	500	427,5	≈2,21					
3808... .06. 100/500.0 .06. 125/500.0 .06. 150/500.0 .06. 200/500.0 .06. 250/500.0	68	103	500	409,5	≈2,30					
3808... .07. 100/500.0 .07. 125/500.0 .07. 150/500.0 .07. 200/500.0 .07. 250/500.0	75	110	500	402,5	≈2,33					
3808... .087.100/500.0 .087.125/500.0 .087.150/500.0 .087.200/500.0 .087.250/500.0	87,5	122,5	500	390	≈2,40					
3808... .10. 100/500.0 .10. 125/500.0 .10. 150/500.0 .10. 200/500.0 .10. 250/500.0	100	135	500	377,5	≈2,46					
3808... – .11. 125/500.0 .11. 150/500.0 .11. 200/500.0 .11. 250/500.0	108	143	500	369,5	≈2,50					
3808... – .12. 125/500.0 .12. 150/500.0 .12. 200/500.0 .12. 250/500.0	125	160	500	352,5	≈2,59					
3808... – – .137.150/500.0 .137.200/500.0 .137.250/500.0	137,5	172,5	500	340	≈2,65					
3808... – – .15. 150/500.0 .15. 200/500.0 .15. 250/500.0	150	185	500	327,5	≈2,72					
3808... – – – .162.200/500.0 .162.250/500.0	162,5	197,5	500	315	≈2,78					
3808... – – – .17. 200/500.0 .17. 250/500.0	168	203	500	309,5	≈2,81					
3808... – – – .18. 200/500.0 .18. 250/500.0	175	210	500	302,5	≈2,84					
3808... – – – .187.200/500.0 .187.250/500.0	187,5	222,5	500	290	≈2,91					
3808... – – – .20. 200/500.0 .20. 250/500.0	200	235	500	277,5	≈2,97					
3808... .05. 100/600.0 .05. 125/600.0 .05. 150/600.0 .05. 200/600.0 .05. 250/600.0	50	85	600	527,5	≈2,21					
3808... .06. 100/600.0 .06. 125/600.0 .06. 150/600.0 .06. 200/600.0 .06. 250/600.0	68	103	600	509,5	≈2,30					
3808... .07. 100/600.0 .07. 125/600.0 .07. 150/600.0 .07. 200/600.0 .07. 250/600.0	75	110	600	502,5	≈2,33					
3808... .087.100/600.0 .087.125/600.0 .087.150/600.0 .087.200/600.0 .087.250/600.0	87,5	122,5	600	490	≈2,40					
3808... .10. 100/600.0 .10. 125/600.0 .10. 150/600.0 .10. 200/600.0 .10. 250/600.0	100	135	600	477,5	≈2,46					
3808... .11. 100/600.0 .11. 125/600.0 .11. 150/600.0 .11. 200/600.0 .11. 250/600.0	108	143	600	469,5	≈2,50					
3808... .12. 100/600.0 .12. 125/600.0 .12. 150/600.0 .12. 200/600.0 .12. 250/600.0	125	160	600	452,5	≈2,59					
3808... .137.100/600.0 .137.125/600.0 .137.150/600.0 .137.200/600.0 .137.250/600.0	137,5	172,5	600	440	≈2,65					
3808... .15. 100/600.0 .15. 125/600.0 .15. 150/600.0 .15. 200/600.0 .15. 250/600.0	150	185	600	427,5	≈2,72					
3808... – – – .162.200/600.0 .162.250/600.0	162,5	197,5	600	415	≈2,78					
3808... – – – .17. 200/600.0 .17. 250/600.0	168	203	600	409,5	≈2,81					
3808... – – – .18. 200/600.0 .18. 250/600.0	175	210	600	402,5	≈2,84					
3808... – – – .187.200/600.0 .187.250/600.0	187,5	222,5	600	390	≈2,91					
3808... – – – .20. 200/600.0 .20. 250/600.0	200	235	600	377,5	≈2,97					

<b>R</b>	<b>100</b>	<b>125</b>	<b>150</b>	<b>200</b>	<b>250</b>
<b>K</b>	500	650	725	875	1050

**Pitch T** = 67 mm/link  
**Links/m** = 15 (1005 mm)

Dimensioning

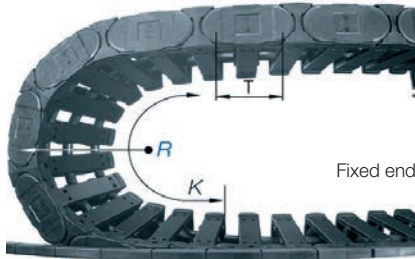
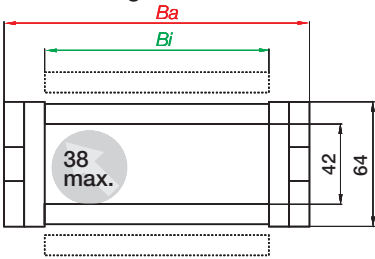

twisterchain® classic | Series 3808 | Interior separation

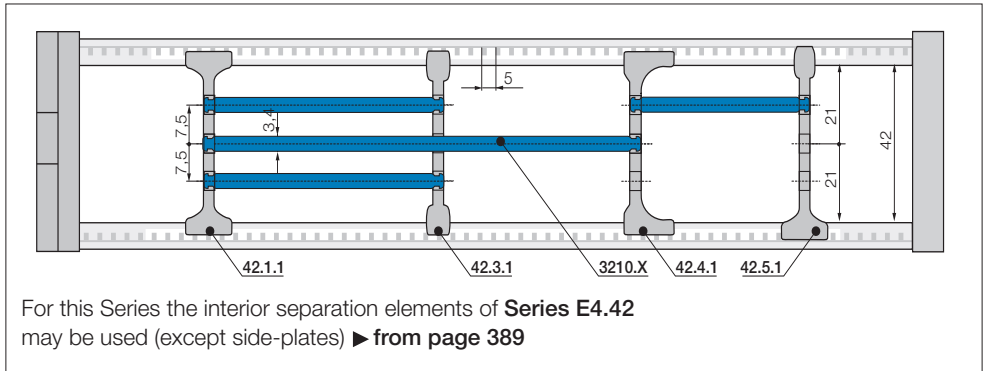

For this Series the interior separation elements of **Series E4.42** may be used (except side-plates) ▶ from page 389



$AR$  = Outer radius, e-chain\*     $Ba$  = Outer width, e-chain\*     $R$  = Bending radius, e-chain\*  
 $IR$  = Inner radius, e-chain\*     $Bi$  = Inner width, e-chain\*     $K$  = Add-on for bending radius

For new constructions we recommend: TC56 ▶ from page 602

## Series 4008 | Snap-open along inner and outer radius

	R 150 [mm]	R 200 [mm]	R 250 [mm]	R 300 [mm]	R 400 [mm]	Bi [mm]	Ba [mm]	AR [mm]	IR [mm]	Weight [kg/m]
4008... .05. 150/650.0 .05. 200/650.0 .05. 250/650.0 .05. 300/650.0 .05. 400/650.0	50	93	650	572	≈3,28					
4008... .06. 150/650.0 .06. 200/650.0 .06. 250/650.0 .06. 300/650.0 .06. 400/650.0	65	108	650	557	≈3,38					
4008... .07. 150/650.0 .07. 200/650.0 .07. 250/650.0 .07. 300/650.0 .07. 400/650.0	75	118	650	547	≈3,44					
4008... – .10. 200/650.0 .10. 250/650.0 .10. 300/650.0 .10. 400/650.0	100	143	650	522	≈3,61					
4008... – .11. 200/650.0 .11. 250/650.0 .11. 300/650.0 .11. 400/650.0	112	155	650	510	≈3,69					
4008... – .12. 200/650.0 .12. 250/650.0 .12. 300/650.0 .12. 400/650.0	125	168	650	497	≈3,77					
4008... – .13. 250/650.0 .13. 300/650.0 .13. 400/650.0	137,5	180,5	650	484,5	≈3,86					
4008... – .15. 250/650.0 .15. 300/650.0 .15. 400/650.0	150	193	650	472	≈3,94					
4008... – .16. 250/650.0 .16. 300/650.0 .16. 400/650.0	162,5	205,5	650	459,5	≈4,02					
4008... – .17. 300/650 .17. 400/650	175	218	650	447	≈4,10					
4008... – .18. 300/650 .18. 400/650	187,5	230,5	650	434,5	≈4,19					
4008... – .200	200	243	650	422	≈4,27					
4008... .05. 150/750.0 .05. 200/750.0 .05. 250/750.0 .05. 300/750.0 .05. 400/750.0	50	93	750	672	≈3,28					
4008... .06. 150/750.0 .06. 200/750.0 .06. 250/750.0 .06. 300/750.0 .06. 400/750.0	65	108	750	657	≈3,38					
4008... .07. 150/750.0 .07. 200/750.0 .07. 250/750.0 .07. 300/750.0 .07. 400/750.0	75	118	750	647	≈3,44					
4008... .10. 150/750.0 .10. 200/750.0 .10. 250/750.0 .10. 300/750.0 .10. 400/750.0	100	143	750	622	≈3,61					
4008... .11. 150/750.0 .11. 200/750.0 .11. 250/750.0 .11. 300/750.0 .11. 400/750.0	112	155	750	610	≈3,69					
4008... – .12. 200/750.0 .12. 250/750.0 .12. 300/750.0 .12. 400/750.0	125	168	750	597	≈3,77					
4008... – .13. 200/750.0 .13. 250/750.0 .13. 300/750.0 .13. 400/750.0	137,5	180,5	750	584,5	≈3,86					
4008... – .15. 200/750.0 .15. 250/750.0 .15. 300/750.0 .15. 400/750.0	150	193	750	572	≈3,94					
4008... – .16. 200/750.0 .16. 250/750.0 .16. 300/750.0 .16. 400/750.0	162,5	205,5	750	559,5	≈4,02					
4008... – .17. 250/750.0 .17. 300/750.0 .17. 400/750.0	175	218	750	547	≈4,10					
4008... – .18. 250/750.0 .18. 300/750.0 .18. 400/750.0	187,5	230,5	750	534,5	≈4,19					
4008... – .20. 250/750.0 .20. 300/750.0 .20. 400/750.0	200	243	750	522	≈4,27					
4008... .05. 150/850.0 .05. 200/850.0 .05. 250/850.0 .05. 300/850.0 .05. 400/850.0	50	93	850	772	≈3,28					
4008... .06. 150/850.0 .06. 200/850.0 .06. 250/850.0 .06. 300/850.0 .06. 400/850.0	65	108	850	757	≈3,38					
4008... .07. 150/850.0 .07. 200/850.0 .07. 250/850.0 .07. 300/850.0 .07. 400/850.0	75	118	850	747	≈3,44					
4008... .10. 150/850.0 .10. 200/850.0 .10. 250/850.0 .10. 300/850.0 .10. 400/850.0	100	143	850	722	≈3,61					
4008... .11. 150/850.0 .11. 200/850.0 .11. 250/850.0 .11. 300/850.0 .11. 400/850.0	112	155	850	710	≈3,69					
4008... .12. 150/850.0 .12. 200/850.0 .12. 250/850.0 .12. 300/850.0 .12. 400/850.0	125	168	850	697	≈3,77					
4008... .13. 200/850.0 .13. 250/850.0 .13. 300/850.0 .13. 400/850.0	137,5	180,5	850	684,5	≈3,86					
4008... – .15. 200/850.0 .15. 250/850.0 .15. 300/850.0 .15. 400/850.0	150	193	850	672	≈3,94					
4008... – .16. 200/850.0 .16. 250/850.0 .16. 300/850.0 .16. 400/850.0	162,5	205,5	850	659,5	≈4,02					
4008... – .17. 200/850.0 .17. 250/850.0 .17. 300/850.0 .17. 400/850.0	175	218	850	647	≈4,10					
4008... – .18. 200/850.0 .18. 250/850.0 .18. 300/850.0 .18. 400/850.0	187,5	230,5	850	634,5	≈4,19					
4008... – .20. 250/850.0 .20. 300/850.0 .20. 400/850.0	200	243	850	622	≈4,27					

R	150	200	250	300	400
K	750	900	1050	1225	1450

Pitch T = 91 mm/link  
Links/m = 11 (1001 mm)

Dimensioning

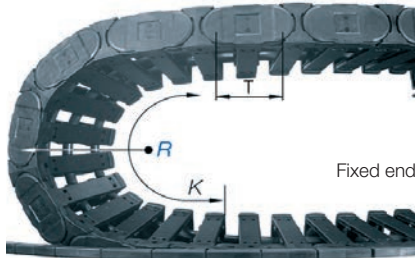
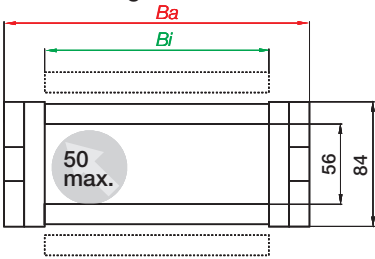

twisterchain® classic | Series 4008 | Interior separation

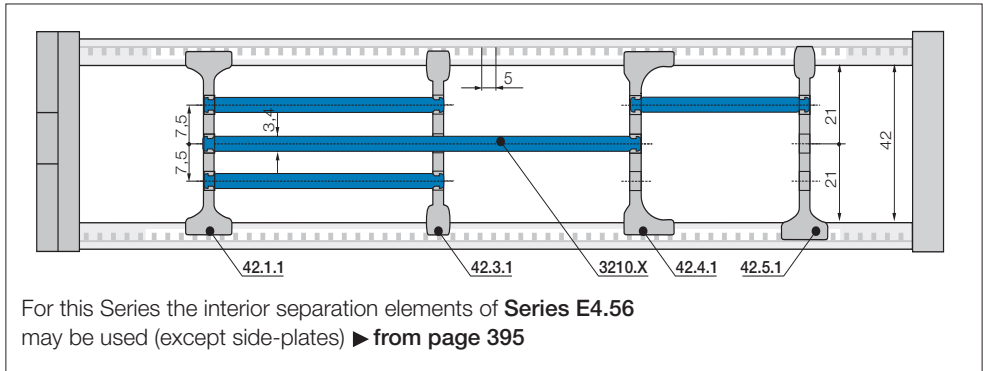

For this Series the interior separation elements of **Series E4.56** may be used (except side-plates) ▶ from page 395



$AR$  = Outer radius, e-chain\*     $Ba$  = Outer width, e-chain\*     $R$  = Bending radius, e-chain\*  
 $IR$  = Inner radius, e-chain\*     $Bi$  = Inner width, e-chain\*     $K$  = Add-on for bending radius



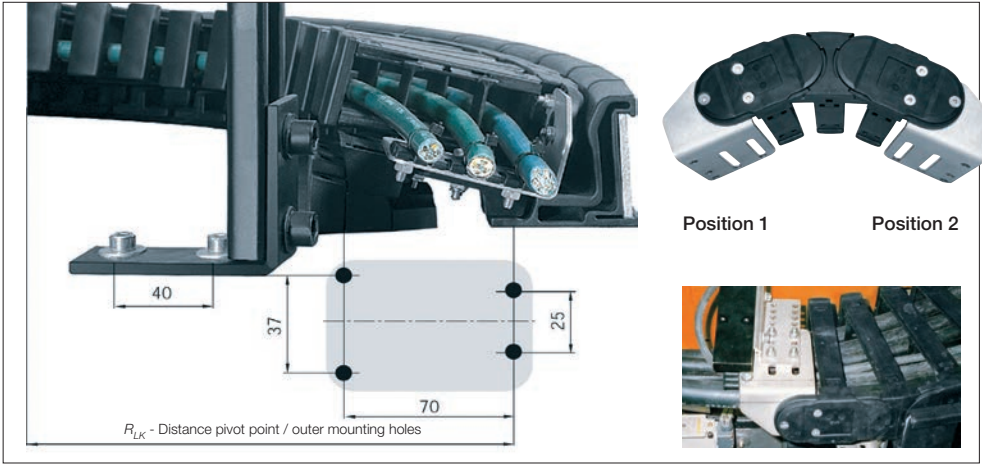

Steel, one-piece | Recommended for unsupported and rotatory applications

For Series	Part No. full set	Part No. position 1	Part No. position 2
2208 ▶	22080.34.VS.E	22080.30.VS.E	22080.40.VS.E
2808 ▶	28080.34.VS.E	28080.30.VS.E	28080.40.VS.E
3808 ▶	38080.34.VS.E	38080.30.VS.E	38080.40.VS.E
4008 ▶	40080.34.VS.E	40080.30.VS.E	40080.40.VS.E

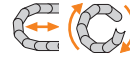

- One part for all e-chain® widths
- Electrically conductive
- Universal use
- Material: Stainless steel: 1.4301

Part No. structure

22080. 34.VS.E



Single-part order

- Position 1  
22080. 30. E
- Position 1  
22080. 40. E

The guide trough must be mounted at the fixed point of the twisterchain®, as shown by the drilling template in the illustration. The following bolted connections are permitted:

- Bore Hole: 4 x Ø 6,6 - 7 mm
- Mounting only with bolts: 4 x bolts M6

Other connection dimensions for mounting

**Note:** twisterchain® e-chains® must always end with an outer side link. At the moving end an outer side link always forms the first e-chain® link. Please note when calculating!

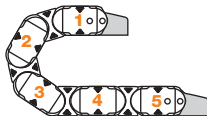

**Guide Trough System - Type 01** ▶ from page 605

Save assembly time and costs - Better guidance for circular motion - increase cycle life!



With the new twisterchain® trough, the previously complex adjustment work is clearly minimized. Assembly time is reduced from 6h to 2h. While reducing noise levels, travel speed and service life can be increased, thanks to an almost all-plastic design ▶ [www.igus.eu/eu/TCtroughnew](http://www.igus.eu/eu/TCtroughnew)



Guide Trough Type 02 - continues to be available for special applications. Delivery program at ▶ [www.igus.eu/eu/TCtroughclassic](http://www.igus.eu/eu/TCtroughclassic)

**Guide Trough System - Type 02**  
for twisterchain® classic - For new constructions we recommend: New Guide Trough System ▶ from page 605



- Guidance of the twisterchain® classic
- Minimized wear on the e-chain®
- Optimal running smoothness
- Rotation angle up to 400°

Guide Trough Type 02 - continues to be available for special applications. Delivery program at ▶ [www.igus.eu/eu/TCtroughclassic](http://www.igus.eu/eu/TCtroughclassic)

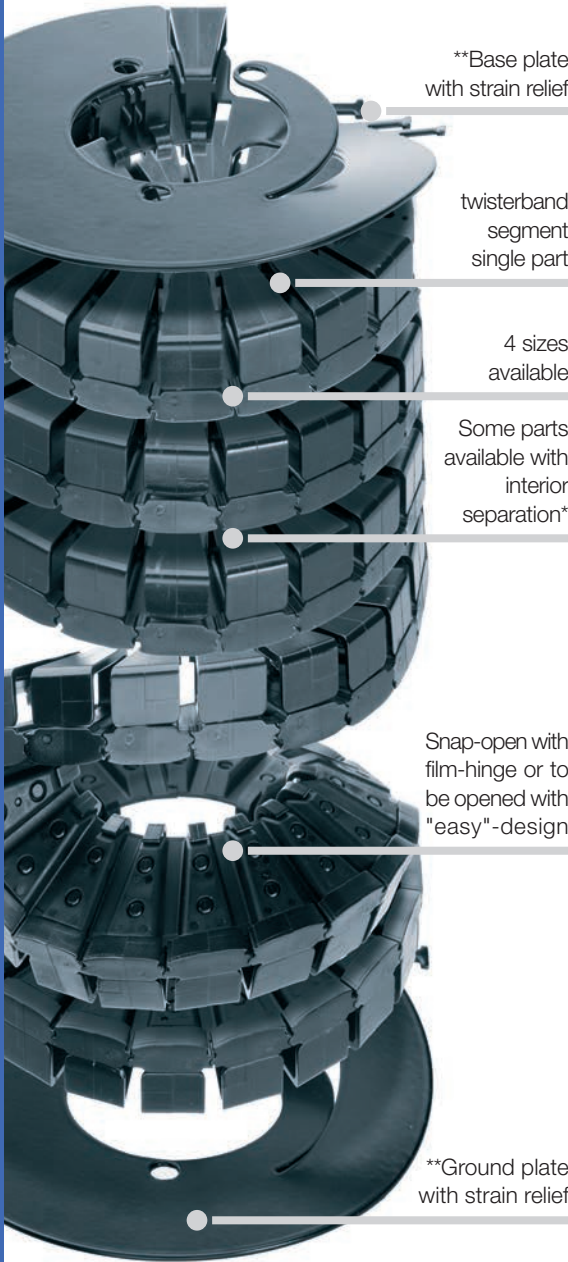

\*\*Base plate with strain relief

twisterband segment single part

4 sizes available

Some parts available with interior separation\*

Snap-open with film-hinge or to be opened with "easy"-design

\*\*Ground plate with strain relief

## twisterband: compact, modular and cost-effective

### Rotary movements in minimum space - 20 times around its own axis

With the very compact igus® twisterband rotations can be implemented economically and with low wear and low maintenance in a confined space. Energy data and media are kept secure.

- 4 sizes available
- Rotary movements up to 7000° (Installation position, vertical: up to 3.000°, horizontal: 7.000° and more possible)
- Rotary speeds up to 360°/s possible
- Compact, modular and lightweight
- Ribbons can be shortened easily
- Minimum installation space, builds very close around the rotary axis
- Can be reliably used in various installation positions (horizontal or vertical)
- Cost-effective
- Easy filling
- chainflex® cables in very limited spaces

### Typical industries and applications

- Cable reels
- Robots (robot arms, 1/6 axis, scara robots)
- Tooling machines
- Leisure rides
- Medical equipment
- Radar and telescope equipment
- Aerospace, test, measurement, handling, lifting and installation equipment
- Wind turbines (e.g. blade adjustment)
- Wherever rotary unions are used



reddot design award winner 2011

\*\*Ground- and base plates are delivered by standard. They are part of the twisterband-module!

# twisterband (7000° rotation) | Selection Table

Series	Inner height <i>hi</i> [mm]	Inner width <i>Bi</i> [mm]	$X_1$ [mm]	$X_2$ [mm]	<i>R min.</i> [mm]	<i>R max.</i> [mm]	Interior separation	Opening principle	Page
<b>TB12.23.09.X.01.0</b>	9	23	40	140	24	35	–	"easy"-design	626
<b>TB20.44.12.X.01.0</b>	12	44	50	220	34	57	–	"easy"-design	626
<b>TB20.44.18.X.01.0</b>	18	44	50	220	34	57	yes	film-hinge	626
<b>TB30.75.22.X.01.0</b>	22	75	90	330	44	77	yes	film-hinge	626

More sizes available upon request!  $X_1$  = Inner machine construction space  $X_2$  = Outer machine construction space



## twisterband

Rotary movements in minimum space - 20 times around its own axis

Installation position, vertical: up to 3.000°, horizontal: 7.000° and more possible

## twisterband Features



An axis is to be centrally installed for angles of rotation from 1500° rotary and horizontal

**360°... 3000°**



Max. rotation angle: As a rule of thumb: Each section gives 180° = 360° more rotation



Film hinge: Easy access and quick filling with cables and hoses (TB20.44.18. / TB30.75.22.)

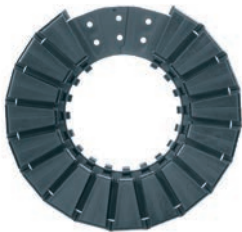

igus® twisterband:  
Minimum installation space, builds very close around the rotary axis



Compact, modular, economical - up to 7.000° rotary\* motions in smallest spaces (\*Installation position, vertical: up to 3.000°, horizontal: 7.000° and more possible)



Can be reliably used in various installation positions (horizontal: 7.000° and more possible). Limited length compensation possible

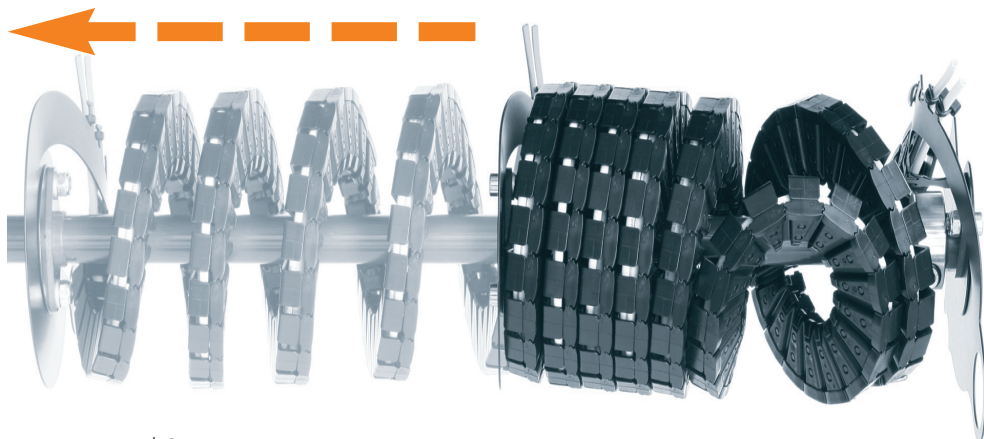

twisterband | Snap-open with film-hinge or with "easy"-principle

Part No. twisterband	Inner width <i>Bi</i> [mm]	Inner height <i>hi</i> [mm]	<i>X</i> <sub>1</sub> [mm]	<i>X</i> <sub>2</sub> [mm]	<i>R min.</i> [mm]	<i>R max.</i> [mm]	Opening principle	<i>d1</i> [mm]
<b>TB12.23.09. X.01.0</b>	23	9	40	140	24	35	easy-principle	7
<b>TB20.44.12. X.01.0</b>	44	12	50	220	34	57	easy-principle	9
<b>TB20.44.18. X.01.0</b>	44	18	50	220	34	57	film-hinge	14
<b>TB30.75.22. X.01.0</b>	75	22	90	330	44	77	film-hinge	17

\*Ground- and base plates are delivered by standard. They are part of the twisterband-module! more twisterband sizes upon request!

Supplement Part No. with required number of ribbons **X** (see calculation box) e.g. **TB20.44.12.6.01.0**

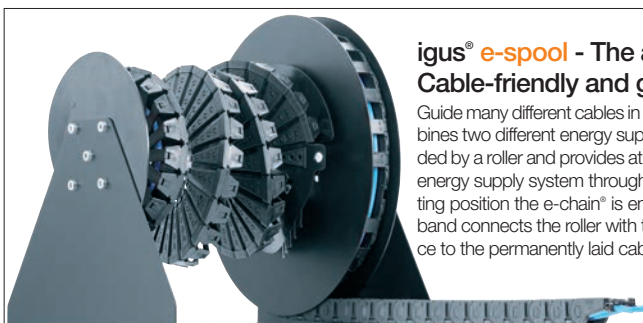

igus® e-spool - The alternative to cable drums.  
Cable-friendly and guides various media safely

Guide many different cables in very narrow spaces. e-spool uniquely combines two different energy supply systems: One standard e-chain® is guided by a roller and provides at any time the right length and tension of the energy supply system through an integrated retaining spring. In the starting position the e-chain® is entirely rolled up to save space. The twisterband connects the roller with the shaft block, which serves as an interface to the permanently laid cables.

- Different media and diameters in the same drum are feasible
- Energy supply in all directions is possible (horizontal, vertical, diagonal ... all possible with one e-chain®)
- Space-saving, no "chain junction"
- No lower run is left behind, the paths remain free
- For cable diameters up to 16 mm

Further information ► [www.igus.eu/e-spool](http://www.igus.eu/e-spool) Delivery time: upon request

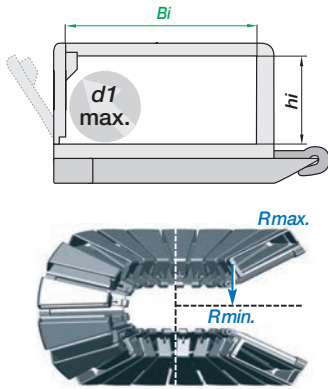
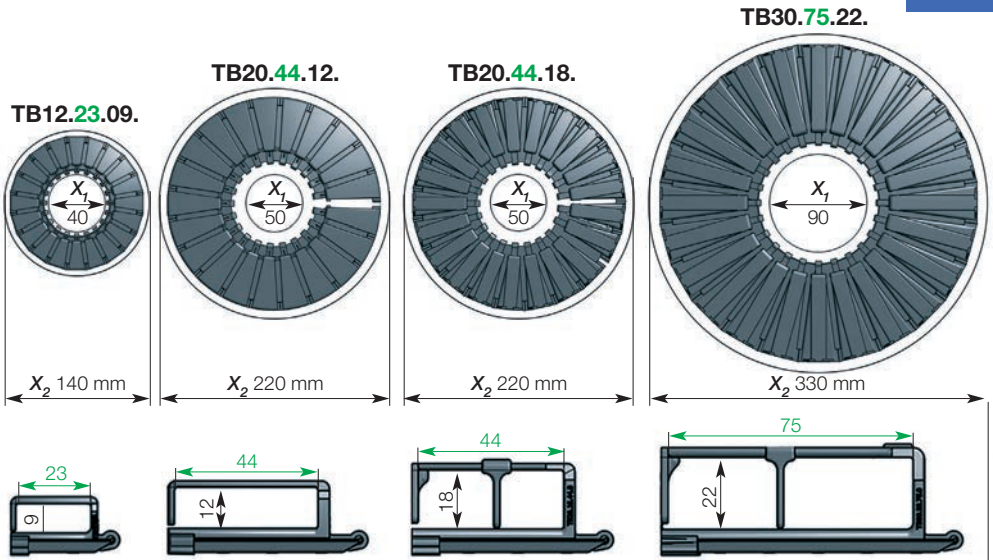

Additional loads depending of the rotation angle

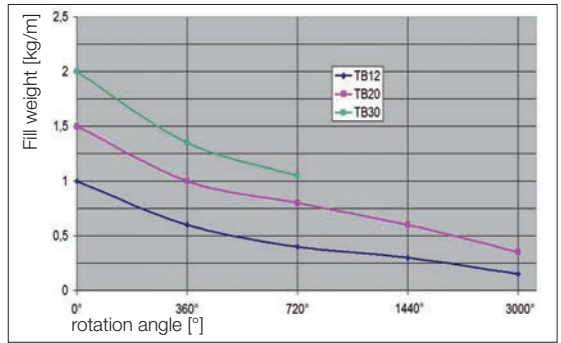

**Calculation: Number of ribbons depending on rotation angle**  
(please always round up number of ribbons)

**TB12:**  $X \approx \frac{\text{Rotation angle}}{360} + 2$  = Example:  $X \approx \frac{1200^\circ}{360} + 2$  = result:  **$X \approx 6$  ribbons**

**TB20:**  $X \approx \frac{\text{Rotation angle}}{340} + 2$  = Example:  $X \approx \frac{1200^\circ}{340} + 2$  = result:  **$X \approx 6$  ribbons**

**TB30:**  $X \approx \frac{\text{Rotation angle}}{180} + 6$  = Example:  $X \approx \frac{1200^\circ}{180} + 6$  = result:  **$X \approx 13$  ribbons**



**Bi** = Inner width e-chain\*    **X<sub>1</sub>** = Inner machine construction space    **R min.** = Min. bending radius    **d1** = Max. cable diameter  
**hi** = Inner height e-chain\*    **X<sub>2</sub>** = Outer machine construction space    **R max.** = Max. bending radius    **X** = Number of ribbons

Interior separation

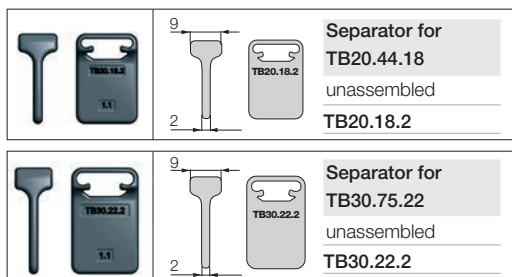
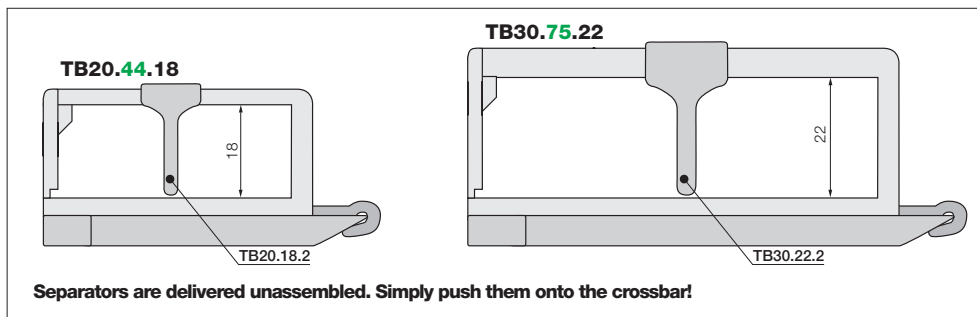

Separators

For Series TB20 with an inner height of 18 mm and Series TB30 (inner height: 22 mm). For installation simply open the e-chain®, insert a cable and push the separator onto the crossbar. Then add more cables. The separators provide a clear, cablefriendly interior separation.



Easy opening and filling of the twisterbandes with a click or with the "easy"-principle. Simply push separators on and add more cables. The separators provide a clear, cable-friendly interior separation.

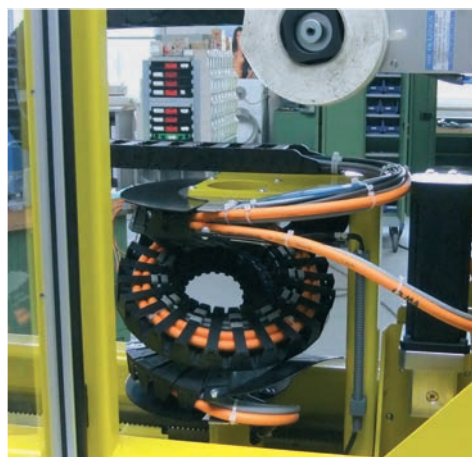

igus® twisterband TB30 for rotations of 360° and E2 mini and E2/000 e-chains® in an un- and loading unit



An igus® twisterband guides the energy of the 5-axis cutting heat in this wood working machine, safe and cost-effective

## Ground- and base plate with strain relief

Dimensions - ground / base plate made of steel with strain relief for the following Series:

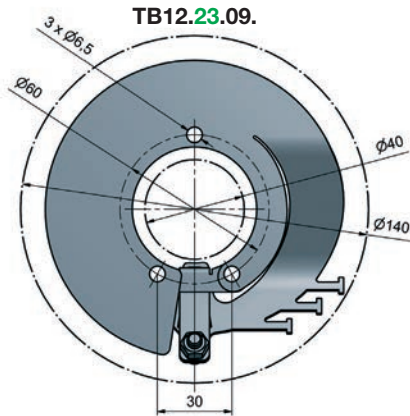

**TB20.44.12. / TB20.44.18.**

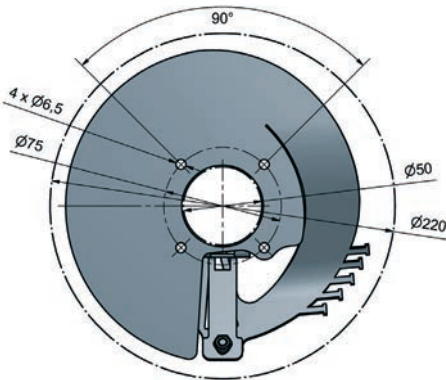

**TB30.75.22.**

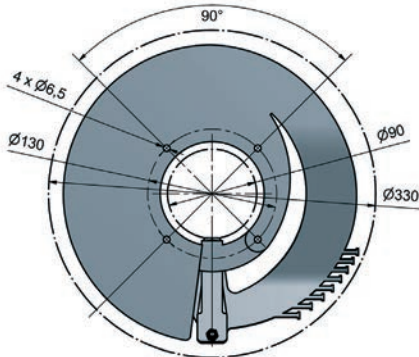

Ground plate and base plate are delivered by standard. They are part of the twisterband-module!



twisterband application of two systems mounted above one another. This space-saving solution allows double filling space with a constant outer diameter of the system





igus

# igus<sup>®</sup> chainfix

strain relief systems

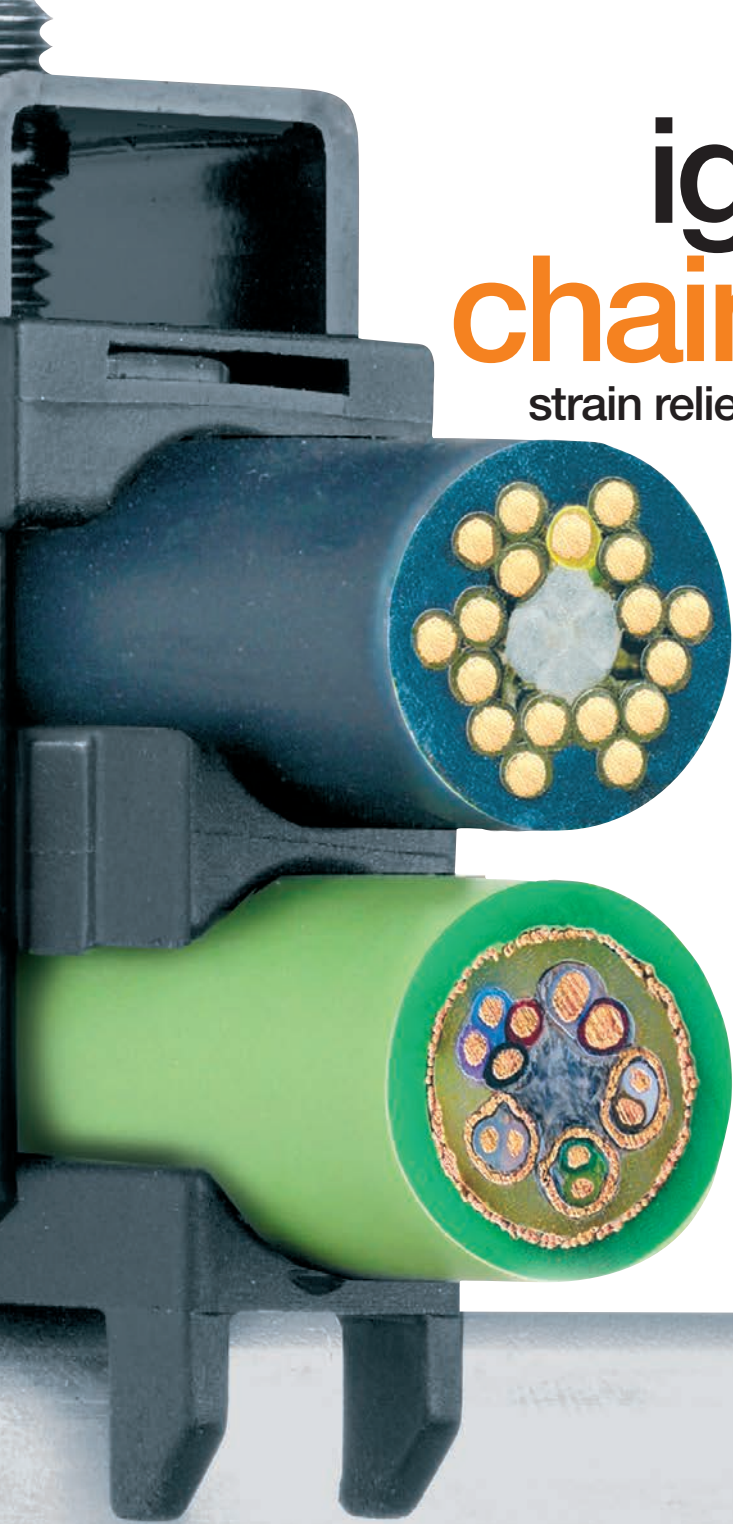

# igus® chainfix strain relief. Flexible, secure and fast.

Strain relief from igus® specifically developed for use in e-chains® and dynamic applications. The combination of chainflex® cable materials in contact with the polymer strain relief components of igus® chainfix are designed for high durability of the cables and maximum holding power. For a wide variety of applications igus® is the best solution in terms of costs and benefits, such as the best chainfix strain relief for long travels or rough use or chainfix Nuggets, for simple and inexpensive strain relief solutions. igus® chainfix strain relief components are under practical for the use by customers around the world.



## Clamps and stainless steel clamps - for maximum pull forces



Clamps and bottom saddle elements, chainfix Multi-Clamps	ø [mm]	page
CFX* Single, double, triple standard clamps	6-42	638
CFXL* Single, double, triple clamps with wide base for maximum pull forces	6-42	639
Saddle elements - bottom and stacker saddles	6-42	640
chainfix Multi-Clamps*	6-12	641

## C-profiles



Standard C-profiles and C-profiles for Heavy-Duty applications	page
Standard C-profiles Part No. CF.92.42. (to be integrated into KMA!)	642
C-profiles Part No. CF.92.52. with increased pull force (mounting in front of e-chain®)	642

## Tiewrap plates - for universal tiewrap, bolted or clip-on



chainfix tiewrap plates	ø [mm]	page
Option 1A: Tiewrap plates as single part "Series 2000" + cable tiewraps		644
Option 1B: Tiewrap plates as single part "Series 3000" + cable tiewraps		645

## Tiewrap plates, with clip-on connection for the C-profile

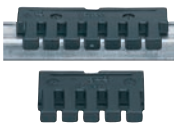

chainfix tiewrap plates	page
Option 2: Tiewrap plates with clip-on connection for the C-profile	646
Option 3: Integrated strain relief for E2 e-tubes - Series R	646
Option 4: Tiewrap plates for fixed crossbars	647
Option 5: Tiewrap plates for opening crossbars	647

## Clips - high pull forces, plug-in



chainfix Clips	ø [mm]	page
Option 1: for all e-chains® with C-profiles and also suitable for assembly in the KMA mounting brackets	4-24	648
Option 2: Clip-on strain relief for opening crossbars	4-24	649

## Strain relief separators - with integrated teeth



chainfix strain relief separator	page
Separator with integrated strain relief - easy strain relief with tiewrap	650

## Nuggets - for top hat rail and C-profile



chainfix Nuggets	ø [mm]	page
Option 1: completely simple and universal cable fixation, for diameter with Ø 20 mm and Ø 30 mm	≤ 30	652
Option 2: Fastening through clipping onto standard top hat rail	≤ 20	652

## Blocks - Special strain relief for hoses



Blocks	ø [mm]	page
Conventional igus® blocks - strain relief for hoses	4,3-14	653
CFB polymer strain relief connector system, many cables in a very confined space		654

\*Standard material: galvanized steel. Also available as stainless steel-version (material stainless steel: 1.4301/AISI 304)

# chainfix | Select your strain relief system

e-chain® Series	Clamps <sup>1)</sup>		Clip C-profile <sup>1)</sup>	chainfix Clip crossbars <sup>1)</sup>	Nugget <sup>1)</sup>	Strain relief separator <sup>2)</sup>
	CFX	CFXL**				
triflex®						
easy triflex®	X**					
triflex®	X**					
easy chain®						
E/Z200	X**					
E/Z26	X**					
E/Z300	X**					
E2/000						
1400/1500	X**	X**				21.1.Z
1450/1480	X**	X**				
2400/2500	X**	X**				2020.Z
2450/2480	X**	X**				2020.ZR
2600/2700	X	X**	X		X	262.Z
2650/2680	X	X**	X		X	
3400/3500	X	X**	X		X	301.Z
3450/3480	X	X**	X		X	34501.Z
255						
E2						
R117/118	X**	X**				
R157/158	X**	X**				1585.01.Z
R167/168	X**	X**				1685.01.Z
R48	X**	X**				481.ZR
R58	X**	X**				
R68	X**	X**				
E4.1						
E4.21	X**	X**				T2103.Z
E4.28/R4.28	X**	X**				upon request
E4.32/H4.32/R4.32	X	X**	X		X	
E4.42/H4.42/R4.42	X	X**	X		X	
E4.56/H4.56/R4.56	X	X**	X	X	X	
E4.80/H4.80/R4.80	X	X**	X	X	X	
E4.112	X**	X**		X		
800	X**	X**				
840	X**					
E4.1 light						
E4.38L	X	X**	X		X	
E4.48L	X	X**	X		X	
E4/light						
14040/14140/18840	X	X**	X	X	X	
14240/14340	X	X**	X		X	
14550/14650/19050	X	X**	X	X	X	
15050/15150/19850	X	X**	X	X		
15250/15350	X	X**	X			
1640/R1608	X	X**		X		
E6						
E6.29	X**	X**				E6.29.02.Z
R6.29	X**	X**				
E6.35	X**	X**				E6.35.02.Z
E6.40	X	X**	X		X	E6.40.02.Z
E6.52	X	X**	X		X	
R6.52	X	X**	X		X	
E6.62	X	X**	X		X	
E6.80L	X	X**	X	X	X	
E6.80	X	X**	X	X	X	
E6.1						
E61.29	X**	X**				E6.29.02.Z
E61.52	X	X**	X		X	

\*\*Clamps must be assembled in front of the e-chain® - Not to be integrated in KMA

# chainfix | Select your strain relief system

chainfix tiwrap plates							
Single part 2000 <sup>2)</sup>	Single part 3000 <sup>2)</sup>	Clip-on for C-profile <sup>2)</sup>	Fixed crossbar <sup>2)</sup>	Cross- bar <sup>2)</sup>	For triflex <sup>2)</sup>	For E2 e-tube <sup>2)</sup>	
					E33X.XX.2 33X.XX		
20XX.ZB	30XX.ZB 30XX.ZB		2050.Z				
20XX.ZB 20XX.ZB 20XX.ZB 20XX.ZB			2050.Z				
	30XX.ZB 30XX.ZB 30XX.ZB 30XX.ZB	30XX.ZC 30XX.ZC 30XX.ZC 30XX.ZC	2050.Z	2050.Z 2050.Z* 30XX.ZS 30XX.ZS*			
20XX.ZB							
20XX.ZB							
20XX.ZB							5850.Z 30XX.Z
20XX.ZB 20XX.ZB				2050.Z			
	30XX.ZB 30XX.ZB 30XX.ZB 30XX.ZB 30XX.ZB 30XX.ZB	30XX.ZC 30XX.ZC 30XX.ZC 30XX.ZC		3850.ZS 3850.ZS 45XX.ZS 45XX.ZS 45XX.ZS			
	30XX.ZB 30XX.ZB	30XX.ZC 30XX.ZC		3850.ZS 3850.ZS			
	30XX.ZB 30XX.ZB 30XX.ZB 30XX.ZB 30XX.ZB 30XX.ZB	30XX.ZC 30XX.ZC 30XX.ZC 30XX.ZC 30XX.ZC		45XX.ZS 3850.ZS 45XX.ZS 45XX.ZS 3850.ZS 45XX.ZS			
20XX.ZB 20XX.ZB 20XX.ZB 20XX.ZB							
	30XX.ZB 30XX.ZB 30XX.ZB 30XX.ZB 30XX.ZB	30XX.ZC 30XX.ZC 30XX.ZC 30XX.ZC		3850.ZS 3850.ZS 45XX.ZS 45XX.ZS			
20XX.ZB							
	30XX.ZB	30XX.ZC		3850.ZS			
	30XX.ZB	30XX.ZC					
	30XX.ZB	30XX.ZC		3850.ZS			
	30XX.ZB	30XX.ZC		45XX.ZS			
	30XX.ZB	30XX.ZC		45XX.ZS			
20XX.ZB							
	30XX.ZB	30XX.ZC		3850.ZS			

■ = Recommended strain relief for selected e-chain\*  
\*Half e-tube only

<sup>1)</sup> you'll find on subsequent page

<sup>2)</sup> you'll find on the product page of each e-chain\* Series

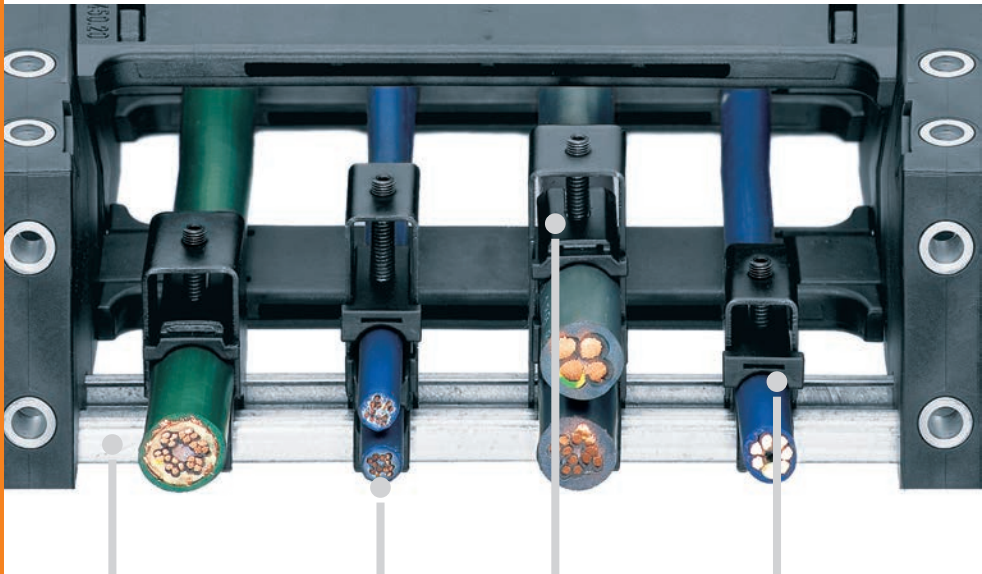

To be integrated into KMA mounting bracket

For up to three cables over one another

Reduced installation height, space saving

Excellent durability for dynamic applications

#### chainfix clamps - flexible, secure and fast

- Integration with KMA mounting brackets and C-profile host-option
- Easy to read the Part no. and lateral marking of the correct installation direction
- Reduced installation height due to optimal housing height (compared to conventional clamps up to 15 mm)
- Space- and time-saving assembly
- Delivery options for complete systems with cables and preassembled strain relief
- Improved base for easy fit on the C-profile
- Setscrews, tightened with Allen wrench, for easy installation
- Durability for dynamic applications through improved stacker elements: optimized stacker saddles, captive by retaining lugs
- The long contact surface of the stacker elements improves the clamp's stability
- The high rigidity of the stacker elements significantly increases the reliability
- Built-in ribs to the stacker elements - no disconnection of cables from the strain relief
- Optional: CFXL clamps with increased holding power for Heavy-Duty applications (CFXL are always assembled in front of the e-chain® - Not integrated into KMA mounting brackets with C-profile-host option!)

## Product range and materials

- Steel clamp: clamp and screw black painted steel
- Stainless steel clamp: clamp and screw: blank (material 1.4301/AISI 304)
- Stacker elements: bottom saddle and stacker saddle (material igumid G)
- C-profiles: steel (material galvanized steel) or stainless steel (material 1.4301/AISI 304) available

## Installation Height

If the e-chain® glides on itself for long travels, the screw heads of the strain relief at the fixed end of the e-chain® must have a distance of at least 10 mm from the top of the e-chain®. This restriction has the consequence that the strain relief elements described herein may not be used at the fixed end of long e-chains®. For unsupported e-chains® strain relief elements can be safely used.



### Please note

- In the ideal case the cables are attached to both ends of the e-chain®. They definitely need to be attached at the moving end of the e-chain®!
- When using chainfix clamps on C-profiles in the mounting bracket for the Series: E4.32/H4.32/R4.32, E4.38L a shortened bottom saddle must be used. For shortened bottom saddles supplement Part No. with index "K" = Example: **Part No. CFX12.1K**



## For the following igus® Series

### E2/000

- 2400/2500/2450/2480
- 2600/2700/2650/2680
- 3400/3500/3450/3480

### E4.1

- E4.32/H4.32/R4.32
- E4.42/H4.42/R4.42
- E4.56/H4.56/R4.56
- E4.80/H4.80/R4.80
- E4.112/H4.112/R4.112

### E4.1 light

- E4.38L
- E4.48L

### E4/light

- 14040/14140/18840
- 14240/14340
- 14550/14650/19050
- 15050/15150/19850
- 15250/15350

### E6

- E6.40
- E6.52 / R6.52
- E6.62
- E6.80L
- E6.80

### E6.1

- E61.52



CFX - chainfix housing with reduced height

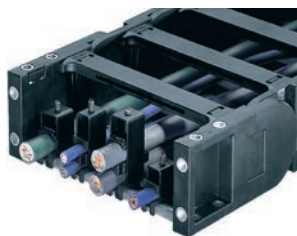

KMA mounting bracket with integrated C-profile and chainfix clamps



Saves both time and space during installation of igus® chainfix clamps



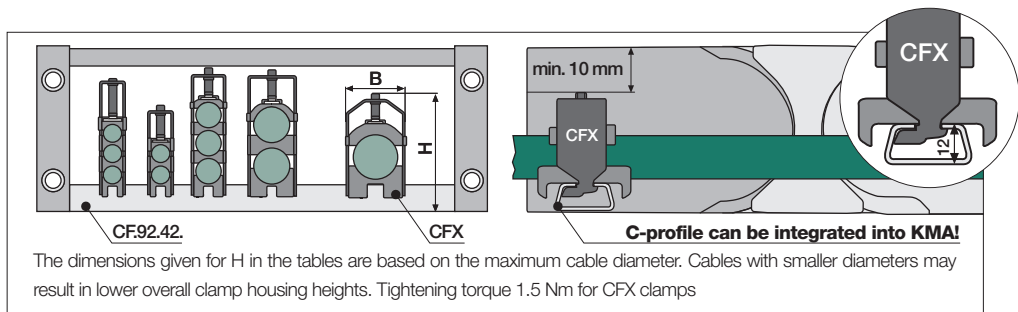

The dimensions given for H in the tables are based on the maximum cable diameter. Cables with smaller diameters may result in lower overall clamp housing heights. Tightening torque 1.5 Nm for CFX clamps



## CFX | Standard clamps with standard base

Suitable for C-profiles CF.92.42.XX - Can be integrated into KMA with C-profile host-option!

### CFX - Single clamp housing, incl. bottom saddles

Part No.	Part No.	∅	B <sup>2</sup>	H	Part No.	Part No.	∅	B <sup>2</sup>	H
Steel	Stainless steel*	[mm]	[mm]	[mm]	steel	Stainless steel*	[mm]	[mm]	[mm]
CFX12.1	CFX12.1.E	06 - 12	16	54	CFX26.1	CFX26.1.E	22 - 26	30	67
CFX14.1	CFX14.1.E	12 - 14	18	50	CFX30.1	CFX30.1.E	26 - 30	34	71
CFX16.1	CFX16.1.E	14 - 16	20	52	CFX34.1	CFX34.1.E	30 - 34	38	75
CFX18.1	CFX18.1.E	16 - 18	22	54	CFX38.1	CFX38.1.E	34 - 38	42	79
CFX20.1	CFX20.1.E	18 - 20	24	56	CFX42.1	CFX42.1.E	38 - 42	46	83
CFX22.1	CFX22.1.E	20 - 22	26	58					

\*Material stainless steel: 1.4301/AISI 304

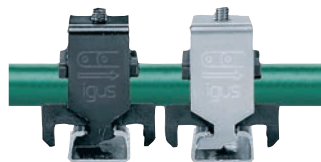

### CFX - Double clamp housing, incl. bottom and stacker saddles

Part No.	Part No.	∅	B <sup>2</sup>	H	Part No.	Part No.	∅	B <sup>2</sup>	H
Steel	Stainless steel*	[mm]	[mm]	[mm]	steel	Stainless steel*	[mm]	[mm]	[mm]
CFX12.2	CFX12.2.E	06 - 12	16	72	CFX22.2	CFX22.2.E	20 - 22	26	90
CFX14.2	CFX14.2.E	12 - 14	18	74	CFX26.2	CFX26.2.E	22 - 26	30	109
CFX16.2	CFX16.2.E	14 - 16	20	78	CFX30.2	CFX30.2.E	26 - 30	34	117
CFX18.2	CFX18.2.E	16 - 18	22	82	CFX34.2	CFX34.2.E	30 - 34	38	125
CFX20.2	CFX20.2.E	18 - 20	24	86					

\*Material stainless steel: 1.4301/AISI 304

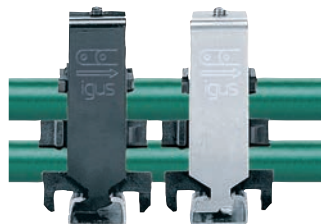

### CFX - Triple clamp housing, incl. bottom and stacker saddles

Part No.	Part No.	∅	B <sup>2</sup>	H	Part No.	Part No.	∅	B <sup>2</sup>	H
Steel	Stainless steel*	[mm]	[mm]	[mm]	steel	Stainless steel*	[mm]	[mm]	[mm]
CFX12.3	CFX12.3.E	06 - 12	16	100	CFX18.3	CFX18.3.E	16 - 18	22	108
CFX14.3	CFX14.3.E	12 - 14	18	96	CFX20.3	CFX20.3.E	18 - 20	24	114
CFX16.3	CFX16.3.E	14 - 16	20	102	CFX22.3	CFX22.3.E	20 - 22	26	120

\*Material stainless steel: 1.4301/AISI 304



Suitable C-profiles for CFX clamps Part No. **CF.92.42.** ▶ page 642

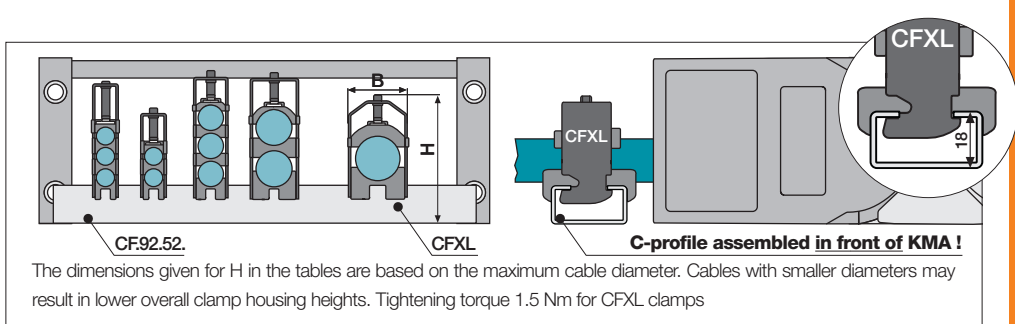

The dimensions given for H in the tables are based on the maximum cable diameter. Cables with smaller diameters may result in lower overall clamp housing heights. Tightening torque 1.5 Nm for CFXL clamps

### CFXL | Clamps with wide base for increased holding power

Suitable for C-profiles CF.92.52.XX - C-profile assembled in front of KMA ! - NO integration!

#### CFXL - Single clamp housing, incl. bottom saddles

Part No.	Part No.	∅	B <sup>2</sup>	H	Part No.	Part No.	∅	B <sup>2</sup>	H
Steel	Stainless steel*	[mm]	[mm]	[mm]	steel	Stainless steel*	[mm]	[mm]	[mm]
CFXL12.1	CFXL12.1.E	06 - 12	16	60	CFXL26.1	CFXL26.1.E	22 - 26	30	73
CFXL14.1	CFXL14.1.E	12 - 14	18	56	CFXL30.1	CFXL30.1.E	26 - 30	34	77
CFXL16.1	CFXL16.1.E	14 - 16	20	58	CFXL34.1	CFXL34.1.E	30 - 34	38	81
CFXL18.1	CFXL18.1.E	16 - 18	22	60	CFXL38.1	CFXL38.1.E	34 - 38	42	85
CFXL20.1	CFXL20.1.E	18 - 20	24	62	CFXL42.1	CFXL42.1.E	38 - 42	46	89
CFXL22.1	CFXL22.1.E	20 - 22	26	64					

\*Material stainless steel: 1.4301/AISI 304

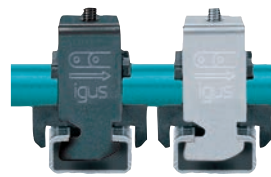

#### CFXL - Double clamp housing, incl. bottom and stacker saddles

Part No.	Part No.	∅	B <sup>2</sup>	H	Part No.	Part No.	∅	B <sup>2</sup>	H
Steel	Stainless steel*	[mm]	[mm]	[mm]	steel	Stainless steel*	[mm]	[mm]	[mm]
CFXL12.2	CFXL12.2.E	06 - 12	16	78	CFXL22.2	CFXL22.2.E	20 - 22	26	86
CFXL14.2	CFXL14.2.E	12 - 14	18	80	CFXL26.2	CFXL26.2.E	22 - 26	30	115
CFXL16.2	CFXL16.2.E	14 - 16	20	84	CFXL30.2	CFXL30.2.E	26 - 30	34	123
CFXL18.2	CFXL18.2.E	16 - 18	22	86	CFXL34.2	CFXL34.2.E	30 - 34	38	131
CFXL20.2	CFXL20.2.E	18 - 20	24	92					

\*Material stainless steel: 1.4301/AISI 304

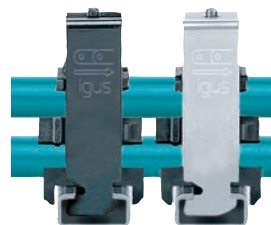

#### CFXL - Triple clamp housing, incl. bottom and stacker saddles

Part No.	Part No.	∅	B <sup>2</sup>	H	Part No.	Part No.	∅	B <sup>2</sup>	H
Steel	Stainless steel*	[mm]	[mm]	[mm]	steel	Stainless steel*	[mm]	[mm]	[mm]
CFXL12.3	-	06 - 12	16	106	CFXL18.3	-	16 - 18	22	114
CFXL14.3	-	12 - 14	18	102	CFXL20.3	-	18 - 20	24	120
CFXL16.3	-	14 - 16	20	108	CFXL22.3	-	20 - 22	26	126

\*Material stainless steel: 1.4301/AISI 304

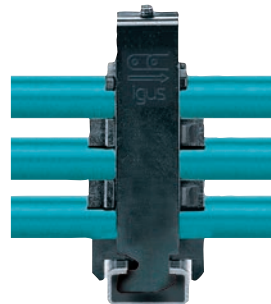

Suitable C-profiles for CFXL clamps Part No. **CF.92.52.** ► page 642

**Characteristics of igus® chainfix clamps - stacker elements**

- Built-in ribs for security of cables in the strain relief
- Optimized stacker saddles, captivated by ① locking spring and with ② spring groove for a simplified and precise installation
- Conventional stacker saddles
- Long contact surface improves the clamp's stability
- More secure due to high stiffness
- Suitable for CFX-and CFXL-clamps



**CGXX | Bottom saddles to slide into the clamp housing as single part**

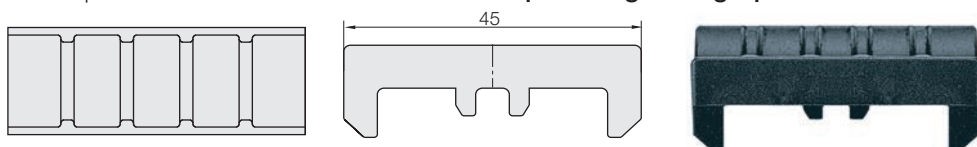

**CDXX | Conventional stacker saddles for all for all double and triple clamps as single part**

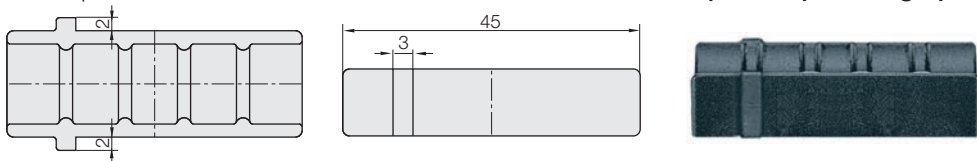

**CD.XX.C | Optimized stacker saddles for all double and triple clamps as single part**

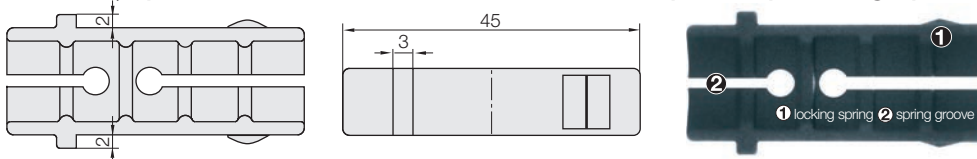

Part No. clamp	Part No. bottom saddle	CDXX stacker saddle	CD.XX.C stacker saddle	Cable Ø [mm]	Part No. clamp	Part No. bottom saddle	CDXX stacker saddle	CD.XX.C stacker saddle	Cable Ø [mm]
CFX/CFXL12.X	CG12	CD12	CD.12.C	06 - 12	CFX/CFXL26.X	CG26	CD26	CD.26.C	22 - 26
CFX/CFXL14.X	CG14	CD14	CD.14.C	12 - 14	CFX/CFXL30.X	CG30	CD30	CD.30.C	26 - 30
CFX/CFXL16.X	CG16	CD16	CD.16.C	14 - 16	CFX/CFXL34.X	CG34	CD34	CD.34.C	30 - 34
CFX/CFXL18.X	CG18	CD18	CD.18.C	16 - 18	CFX/CFXL38.X	CG38	-	-	34 - 38
CFX/CFXL20.X	CG20	CD20	CD.20.C	18 - 20	CFX/CFXL42.X	CG42	-	-	38 - 42
CFX/CFXL22.X	CG22	CD22	CD.22.C*	20 - 22					



**Please note:** When using chainfix clamps on C-profile in the mounting bracket for Series E4.32/H4.32/R4.32, E4.38L a shortened bottom saddle has to be used. The Part No. for this is "K" = example: **Part No. CFX12.1K**

## Characteristics of igus® chainfix Multi-Clamps

- Now more flexible mounting options of the proven chainfix strain relief elements with more components
- Universal strain relief - various assembly options
- Saves both time and space during installation
- Compact and modular
- For small outer diameters
- Cost-effective

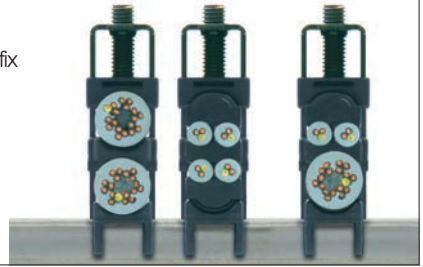



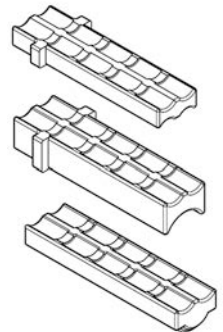
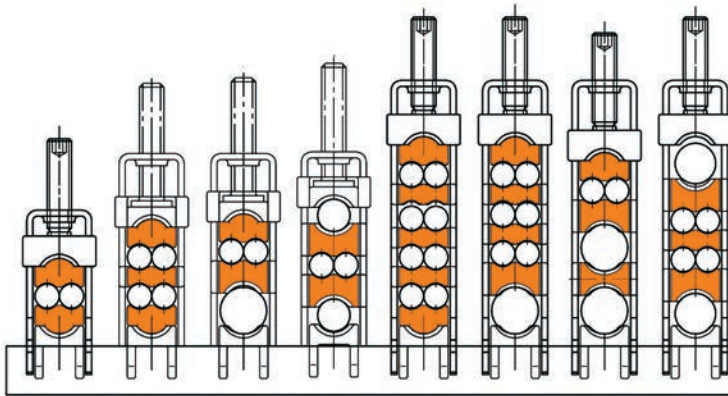

## CFX12 | Multi-Clamps, universal strain relief



Universal bottom and stacker saddles

CFX12.1.Z1 CFX12.2.Z1 CFX12.2.Z2 CFX12.2.Z3 CFX12.3.Z1 CFX12.3.Z2 CFX12.3.Z3 CFX12.3.Z4

Part No. Series	Part No. stacker saddles - single parts				For cables Ø max. [mm]
					
CFX12.1.Z1	X (2-piece)	–	–	–	6
CFX12.2.Z1	X (2-piece)	X (1-piece)	–	–	6
CFX12.2.Z2	X (1-piece)	–	X (1-piece)	–	6 + 12
CFX12.2.Z3	–	–	X (2-piece)	–	6 + 8
CFX12.3.Z1	X (2-piece)	X (3-piece)	–	–	6
CFX12.3.Z2	X (1-piece)	X (2-piece)	X (1-piece)	–	6 + 12
CFX12.3.Z3	X (1-piece)	–	X (1-piece)	X (1-piece)	6 + 12
CFX12.3.Z4	–	X (1-piece)	X (2-piece)	–	6 + 10

Standard material: galvanized steel. For the stainless steel version (material 1.4301/AISI 304) supplement Part No. with Index "E" = example: **Part No. CFX.12.3.Z1.E**

**Standard C-profiles Part No. CF.92.42.XX**

- For all igus® CFX clamps und KMA-mounting brackets with C-profile host-option

- Standard material: galvanized steel

**Part No. CF.92.42.XX** (XX = length in mm)

- Also available as stainless steel version (Material stainless steel: 1.4301/AISI 304) please add Index **.E**, example: **Part No. CF.92.42.XX.E**
- Length tolerances of  $\pm 1$  mm possible!

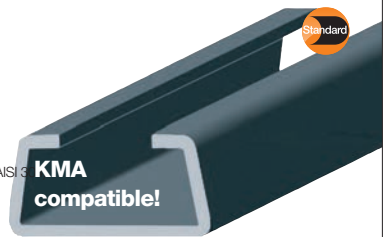
**Standard C-profile Part No. CF.92.42. | For conventional applications**

Can be integrated into KMA with C-profile host-option!

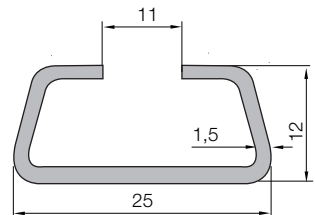
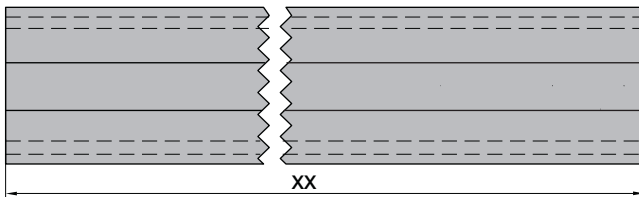
**Optional | For Heavy-Duty applications****C-profiles Part No. CF.92.52.XX**

- For all igus® CFXL clamps
  - With increased holding power - even for harsh applications
  - Standard material: galvanized steel
- Part No. CF.92.52.XX** (XX = length in mm)
- Also available as stainless steel version (Material: 1.4301/AISI 304) please add Index **.E**, example: **Part No. CF.92.52.XX.E**
  - Length tolerances of  $\pm 5$  mm possible!

**C-profile Part No. CF.92.52. | With increased holding power for harsh conditions**

Assembly in front of the e-chain® - NO integration into KMA!

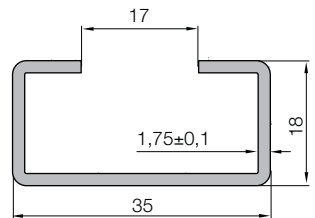
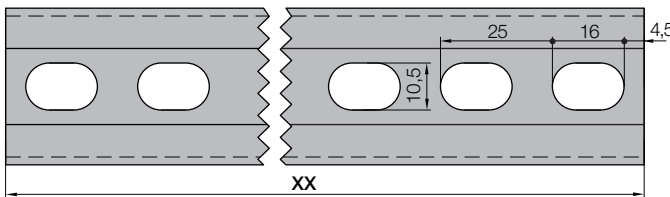



igus® tensile strength test with CFX clamps

**igus® strain relief devices are tested under practical conditions, taking various parameters into account**

Whether under the influence of fluids like water or oil, or at different ambient temperatures. The interaction of chainfix systems with different sheath materials of cables and hoses of course plays a big role in the in-house tests.

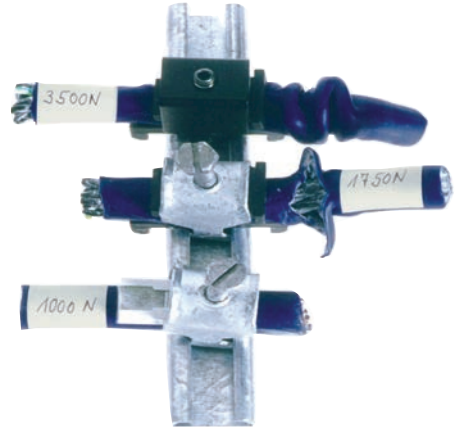

igus® test: Comparison of three different strain reliefs - Result: Triple tensile strength of igus® chainfix clamps in comparison with conventional products.

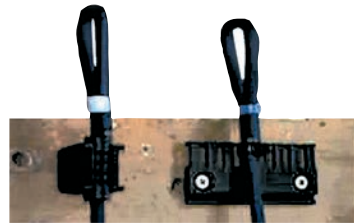

Tensile strength tests with chainflex® cables

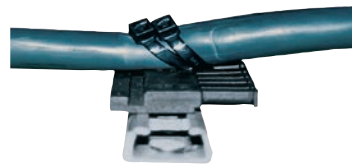

Tensile strength tests of igus® clamps with cable tiewraps

**Characteristics of igus® chainfix tiewrap plate Series 2000**

**Option 1A: Tiewrap plate as single part**

- Available as individual component
- Screwed on KMA\* with C-profile (\*polymer metal mounting bracket)
- Can be stacked onto the mounting bracket
- Single part for the manufacturing of switchgear cabinets or for the assembly of machines
- Accessory for igus® e-chainsystems®

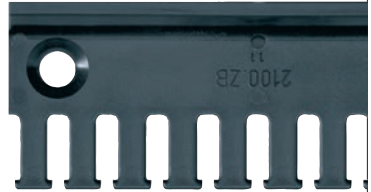

**Series 2000 | Tiewrap plate as single part**

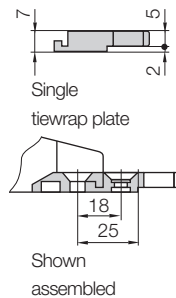
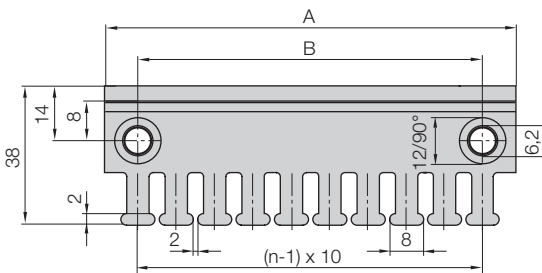

**For the following igus® Series**

- easy chain®**
  - E200/Z200
- E2/000**
  - 1400/1500/1450/1480
  - 2400/2500/2450/2480
  - 255
- E2 e-tubes**
  - R117/R118
  - R48
- E4.1**
  - E4.21
  - E4.28
- E6**
  - E6.29/R6.29
  - E6.35
  - E6.40
- E6.1**
  - E61.29

Tiewrap plate	n Number of teeth	Dim. A [mm]	Dim. B [mm]	Dim. C [mm]	Center bore -- = no / + = yes
2020.ZB	3	30	15	-	-
2030.ZB	4	40	20	-	-
2040.ZB	5	50	30	-	-
2050.ZB	6	60	40	-	-
2070.ZB	8	80	60	-	-
2090.ZB (= 2030.ZB + 2040.ZB)	9	90	-	-	-
2100.ZB	10	100	80	-	-
2125.ZB (= 2050.ZB + 2050.ZB)	12	120	-	-	-

**Cable tiewraps as single part**

Cable tiewraps (100-piece bag)	Width x length [mm]	Maximum Ø	Pull force resistance [N]
CFB.001	4,8 x 150	36	222 N

**Characteristics of igus® chainfix tiewrap plate Series 3000**

**Option 1B: Tiewrap plate as single part**

- Available as individual component
- Screwed on KMA\* with C-profile (\*polymer metal mounting bracket)
- Can be stacked onto the mounting bracket
- Single part for the manufacturing of switchgear cabinets or for the assembly of machines
- Accessory for igus® e-chainsystems®



**Series 3000 | Tiewrap plate as single part**

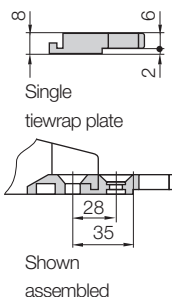
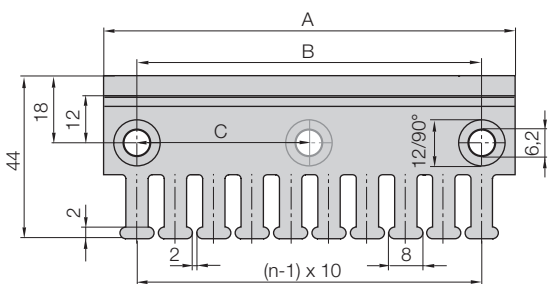

**For the following igus® Series**

**easy chain®**

- E26/Z26
- E300/Z300

**E2/000**

- 2600/2700/2650/2680
- 3400/3500/3450/3480

**E4.1**

- E4.32/H4.32/R4.32
- E4.42/H4.42/R4.42
- E4.56/H4.56/R4.56
- E4.80/H4.80/R4.80
- E4.112/H4.112/R4.112
- 800
- 840

**E4.1 light**

- E4.38L
- E4.48L

**E4/light**

- 14040/14140/18840
- 14240/14340
- 14550/14650/19050
- 15050/15150/19850
- 15250/15350
- 1640/1608

**E6**

- E6.52/R6.52
- E6.62
- E6.80L / E6.80

**E6.1**

- E61.52

Tiewrap plate	n Number of teeth	Dim. A [mm]	Dim. B [mm]	Dim. C [mm]	Center bore - = no / + = yes
3050.ZB	5	50	30	-	-
3075.ZB	7	75	55	-	-
3100.ZB	10	100	80	-	-
3115.ZB	11	115	95	-	-
3125.ZB	12	125	105	-	-
3150.ZB	15	150	130	-	-
3175.ZB	17	175	155	-	-
3200.ZB	20	200	180	90	+
3225.ZB	22	225	205	102,5	+
3250.ZB	25	250	230	115	+

**Cable tiewraps as single part**

Cable tiewraps (100-piece bag)	Width x length [mm]	Maximum $\varnothing$	Pull force resistance [N]
CFB.001	4,8 x 150	36	222 N



**Characteristics of igus® chainfix tiewrap plates****Option 2: With clip-on connection for the C-profile**

- Can be plugged into the KMA C-profile
- Easy to assemble without any screws
- Easy to remove with screwdriver nevertheless safe stop
- Single part for the manufacturing of switchgear cabinets or for the assembly of machines
- Accessory for igus® e-chainsystems®

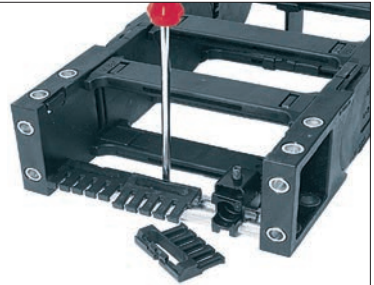
**Option 2 | Tiewrap plate with clip-on connection for C-profile**

For all mounting brackets with C-profile connectivity!

Part No.	Width [mm]	Number of teeth
3050.ZC	50	5
3075.ZC	75	7

**Characteristics of igus® chainfix tiewrap plates****Option 3: integrated strain relief for E2 e-tubes - Series R**

- Strain relief disappears completely in the e-tube
- Easy to assemble without any screws
- Single part for the manufacturing of switchgear cabinets or for the assembly of machines
- Accessory for igus® e-chainsystems®

**Option 3 | Tiewrap plate for E2 e-tubes of Series R**

For the following igus® Series  
► see table

Part No.	Width [mm]	Number of teeth	For Series
3050.Z*	50	5	R68
3075.Z	75	7	R68
5850.Z	46	4	R58

\*only possible from e-chain\* width 100 mm and larger

**Characteristics of igus® chainfix tiewrap plates**

**Option 4: for fixed crossbars** **Option 5: For opening crossbars**

- Can be fitted to fixed and opening crossbars
- In case of many harnessed cables
- Strain relief "over two floors"
- If the KMA is too small for the C-profile
- Easy to assemble without any screws
- Accessory for igus® e-chainsystems®

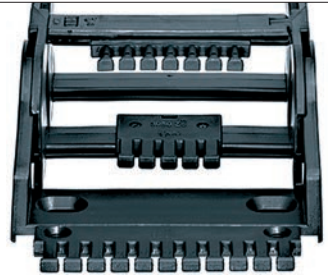

**Option 4 | Tiewrap plate for fixed crossbars**

Part No.	Width [mm]	Number of teeth	For Series
2050.Z	60	6	E/Z200, 2400/2500, 2600/2700
3050.Z	50	5	3400/3500
3075.Z	74	7	3400/3500



For the following igus® Series  
▶ see table

**Option 5 | Tiewrap plate for opening crossbars**

Part No.	Width [mm]	Number of teeth	For Series
2050.Z	60	6	E4/H4/R4.28, 2650
3035.ZS	35	3	3400/3500
3050.ZS	50	5	3400/3500
3075.ZS	75	7	3400/3500
3850.ZS	48	5	E4/H4/R4.32, E4/H4/R4.42, 14240/14340, 15250/15350, E6.52, E6.62, E61.52
4550.ZS	48	5	E4/H4/R4.56, E4/H4/R4.80, E4/H4/R4.112, 14040/14140/18840, 14550/14650/19050, 15050/15150/19850, E6.80L, E6.80, 1640/1608
4575.ZS	74	7	E4/H4/R4.56, E4/H4/R4.80,, E4/H4/R4.112, 14040/14140/18840, 14550/14650/19050, 15050/15150/19850, E6.80L, E6.80, 1640/1608



For the following igus® Series  
▶ see table

### Characteristics of igus® chainfix Clips -

#### Option 1: Modular clip-on strain relief for the C-profile

- Available for all igus® e-chains® with C-profiles
- Also suitable for assembly in the KMA mounting brackets
- Polymer, for cable diameters ranging from 4 mm to 24 mm
- Quick assembly without any tools
- 2 and 3 layers on top of one another possible
- Each layer can be detached and changed later on



### Option 1 | Clip-on strain relief for the C-profile



For all mounting brackets with C-profile connectivity!

#### Clamp - Part No. CFC-XX-M

ø Cable [mm]	Part No. clamp	Dim. A [mm]	Dim. B [mm]	Dim. C [mm]	Dim. D [mm]	Dim. E [mm]
04 - 08 mm	<b>CFC-08-M</b>	14,5	13	5,5	7,5	30
08 - 12 mm	<b>CFC-12-M</b>	23,7	24	10	14	36
12 - 16 mm	<b>CFC-16-M</b>	32,4	32,5	13,6	18,9	42
16 - 20 mm	<b>CFC-20-M</b>	43,2	39,1	17,6	11,5	45
20 - 24 mm	<b>CFC-24-M</b>	54	49	22	27	50

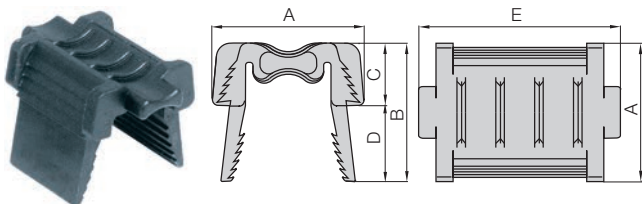

#### Bottom part - Part No. CFC-XX-C

ø Cable [mm]	Part No. bottom part	Dim. A [mm]	Dim. B [mm]	Dim. C [mm]	Dim. D [mm]	Dim. E [mm]
04 - 08 mm	<b>CFC-08-C</b>	14,5	12,5	5,5	7	24
08 - 12 mm	<b>CFC-12-C</b>	23,8	18	11	7	28
12 - 16 mm	<b>CFC-16-C</b>	32,4	23,6	13,6	10	32
16 - 20 mm	<b>CFC-20-C</b>	43,2	24,6	17,6	7	36
20 - 24 mm	<b>CFC-24-C</b>	54	29	22	7	39

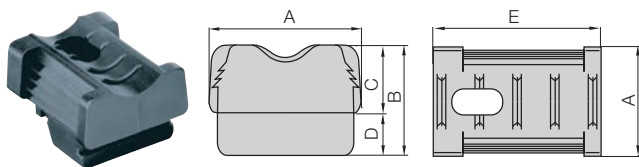

## Characteristics of igus® chainfix Clips -

### Option 2: Clip-on strain relief for opening crossbars

- Available for all e-chains® with opening crossbars **Part No. 450.XX.**
- Polymer, for cable diameters ranging from 8 mm to 12 mm
- Quick assembly without any tools
- 2 and 3 layers on top of one another possible
- Each layer can be detached and changed later on

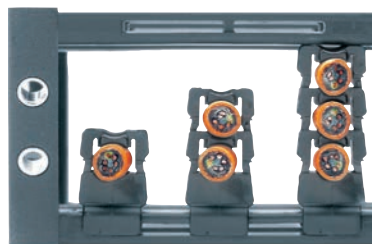

## Option 2 | Clip-on strain relief for opening crossbars

### Clamp - Part No. CFC-XX-M

ø Cable [mm]	Part No. clamp	Dim. A [mm]	Dim. B [mm]	Dim. C [mm]	Dim. D [mm]	Dim. E [mm]
08 - 12 mm	<b>CFC-12-M</b>	23,7	24	10	14	36

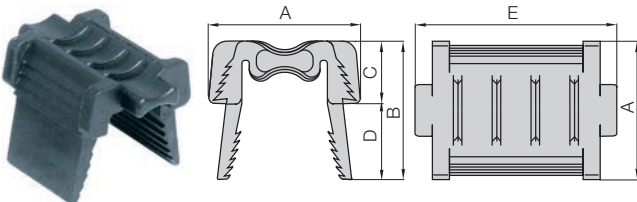

### Bottom part - Part No. CFC-XX-B

ø Cable [mm]	Part No. bottom part	Dim. A [mm]	Dim. B [mm]	Dim. C [mm]	Dim. D [mm]	Dim. E [mm]
08 - 12 mm	<b>CFC-12-B</b>	23,8	21	13	8	38

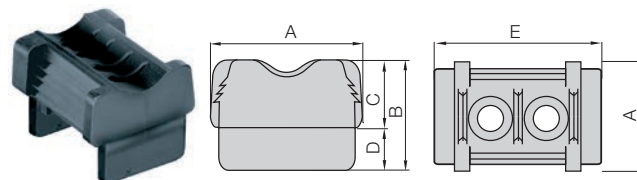

For the following igus® Series

- E4.1**
  - E4.56/H4.56/R4.56
  - E4.80/H4.80/R4.80
  - E4.112/H4.112/R4.112
  - 840
- E4/light**
  - 14040/14140
  - 14550/14650
  - 15050/15150
  - 1640
- E6**
  - E6.80L
  - E6.80

### Characteristics of igus® strain relief separators - Separator with integrated strain relief teeth

- To be used assembled either at the first or last e-chain® link
- For restricted space conditions
- Accessory for igus® e-chainsystems®
- Easy to assemble without any screws
- The number n is depending on the selection of cable (diameter, type) and available space



### Strain relief separator | with integrated teeth

For Series	Part No. strain relief separator	Number of teeth	Dim. A [mm]	Dim. B [mm]	Dim. C [mm]	Dim. D ø [mm]
1400/1500	▶ 21.1.Z	2	10	4	-	6
2400/2500	▶ 2020.Z	2	10	4	-	6
2450/2480	▶ 2020.ZR	2	10	4	-	6
2600/2700	▶ 262.Z	3	10	4	-	6
3400/3500	▶ 301.Z	3	18	4	-	14
3450/3800	▶ 34501.Z	3	14	4	-	10
R157/R158	▶ 1585.01.Z	3	22	4	-	18
R167/R168	▶ 1685.01.Z	4	22	4	-	18
R48	▶ 481.ZR	2	10	3,5	10	6,5
E4.21	▶ T2103.Z	2	8	4	13	4
E6.29/E61.29	▶ E6.29.02.Z	2	8	4	12	4
T3.29	▶ E6.29.02.Z	2	8	4	12	4
E6.35	▶ E6.35.02.Z	3	8	4	12	4
E6.40	▶ E6.40.02.Z	3	13	4	-	8

Dimensions: see drawing on the right!

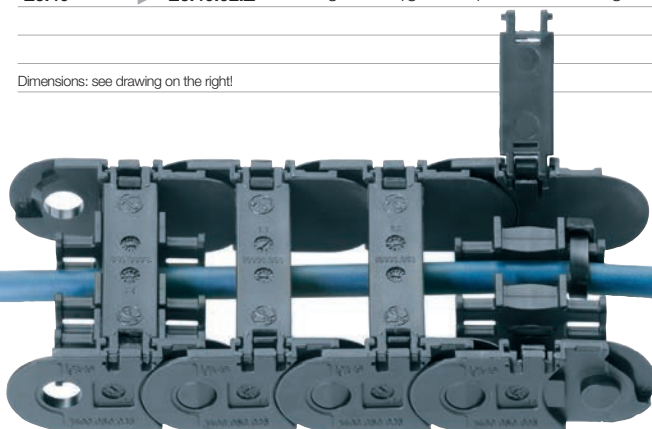

For the following igus® Series

#### E2/000

- 1400/1500
- 2400/2500
- 2450/2480
- 2600/2700
- 3400/3500
- 3450/3480

#### E2 e-tubes

- R157/R158
- R167/R168
- R48

#### E4.1

- E4.21

#### T3

- T3.29

#### E6

- E6.29
- E6.35
- E6.40

#### E6.1

- E61.29

Strain relief separators are assembled either at the first or last e-chain® link. For an intermediate strain relief they can alternatively be assembled in the e-chain®.

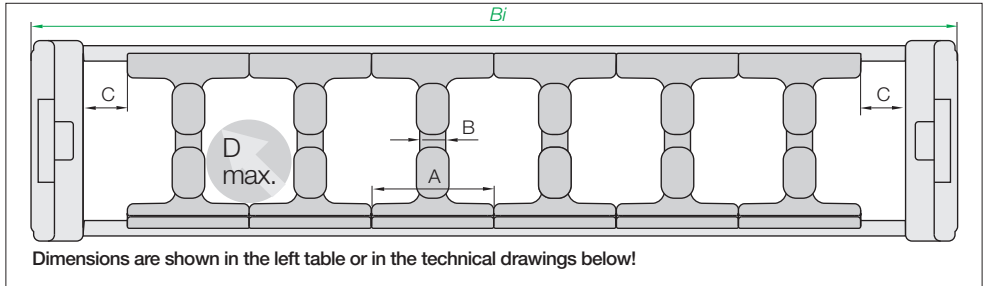

**Strain relief separators | Delivery program overview**

		<p><b>1400/1500</b> E2/000 e-chains® unassembl. 21.1.Z assembled 21.1.Z.1</p>			<p><b>R157/R158</b> E2 e-tubes unassembl. 1585.01.Z assembled 1586.01.Z</p>
		<p><b>2400/2500</b> E2/000 e-chains® unassembl. 2020.Z assembled 2120.Z</p>			<p><b>R167/R168</b> E2 e-tubes unassembl. 1685.01.Z assembled 1686.01.Z</p>
		<p><b>2450/2480</b> E2/000 e-tubes unassembl. 2020.ZR assembled 2120.ZR</p>			<p><b>R48</b> E2 e-tubes unassembl. 481.ZR assembled 482.ZR</p>
		<p><b>2600/2700</b> E2/000 e-chains® unassembl. 262.Z assembled 263.Z</p>			<p><b>E6.29/E61.29</b> E6/E6.1 e-chains® unassembl. E6.29.02.Z assembled E6.29.12.Z</p>
		<p><b>3400/3500</b> E2/000 e-chains® unassembl. 301.Z assembled 311.Z</p>			<p><b>T3.29</b> T3 e-chains® unassembl. E6.29.02.Z assembled E6.29.12.Z</p>
		<p><b>3450/3480</b> E2/000 e-tubes unassembl. 34501.Z assembled 34511.Z</p>			<p><b>E6.35</b> E6 e-chains® unassembl. E6.35.02.Z assembled E6.35.12.Z</p>
		<p><b>E4.21</b> E4.1 e-chains® unassembl. T2103.Z assembled T2113.Z</p>			<p><b>E6.40</b> E6 e-chains® unassembl. E6.40.02.Z assembled E6.40.12.Z</p>

### Characteristics of igus® chainfix Nuggets

#### Option 1: C-profile and Option 2: top hat rail

- **Option 1:** Universal cable fixation in C-profile
- **Option 2:** Clip onto a top hat rail
- Simple strain relief - harnessed cable tiwraps
- Minimum space required
- Easy to assemble without any screws and tools
- Adjustable to every e-chain® filling

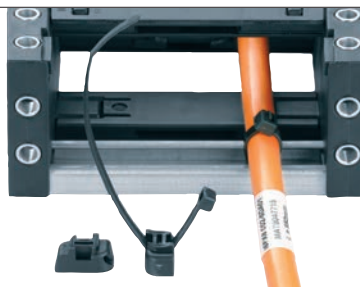

### Option 1 | chainfix Nuggets for the C-profile

For C-profiles	Part No. Nugget	ø Cable max. [mm]	Dim. A [mm]
92.42.../92.42...E	CFN.20	20	10,8
92.52.../92.52...E	CFN.30.52	30	16,4



For all mounting brackets with C-profile host-option!

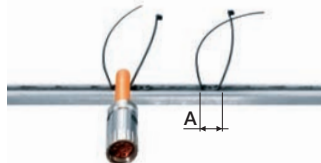

### Option 2 | chainfix Nuggets for the top hat rail

For top hat rail	Part No. Nugget	ø Cable max. [mm]	Dim. A [mm]
	CFN.20.N35	20	20,0



For top hat rail 35!

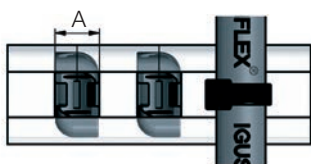
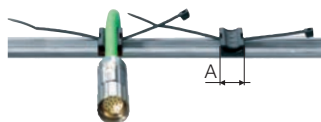

## Characteristics of special strain relief for hoses - igus® blocks

- Modular, space-saving system
- No hose damage
- Combination of hoses and cables possible
- Hose diameters: 4,3 - 14 mm
- Easy to assemble without any screws or tools
- Adjustable to every e-chain® filling



## Block | Strain relief for hoses

Part No. Block modules	Hose Ø [mm]	Number of hoses	Width [mm]
CFS 4,3	4,3	4 - 12	27,5
CFS 6	6	3 - 6	27,5
CFS 9	9	2	27,5
CFS 55,9	9	5	55,0
CFS 10	10	2	27,5
CFS 12	12	2	27,5
CFS 14	14	1	27,5
Part No. Base plate	Part No. Cover plate	Width [mm]	
CFS U75	CFS P75	75	
CFS U102,5	CFS P102,5	102,5	
CFS U130	CFS P130	130	
CFS U185	CFS P185	185	
CFS U212	CFS P212	212,5	
CFS U240	CFS P240	240	
CFS U295	CFS PD295	295	
Part No. Spacer	Height [mm]		
CFS D 16	16		
CFS D 12	12		
CFS D295	16		

 Please contact igus® for individual designing



- ① Cover plate
- ② Spacers
- ③ Base plate
- ④ Grid-dimensioned modules  
B = 27,5 mm, H = 16 mm

The modules accommodate hoses from 4.3 to 14 mm, 3 x 4.3 mm hoses can be fitted on top of each in module CFS 4.3 and 2 hoses can be fitted directly on top of each other in one notch using module CFS 6. The modules have a width of 27.5 mm, are inserted into the base plate and then fastened in position with M4 countersunk-head screws. The exception is module CFS 55.9 which offers the capacity for 5 x 9 mm hoses with twice the width. The base plate and cover plate are available in widths ranging from 75 to 240 mm. The height of the spacers and modules is 16 mm. Several layers can be installed directly above one another.



**Characteristics of the modular igus® CFB: Polymer strain relief connector system to be mounted onto the C-profile**

- Customized strain relief solutions can be offered
- 2 variations available
- Fast assembly by standard screw connection
- Can be mounted in the mounting bracket or in front of the e-chain®
- Customized production from 1 piece
- Low priced and effective

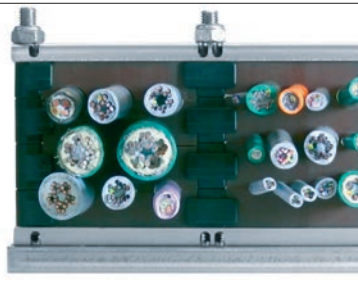
**CFB 907.881. | Polymer strain relief connector system**

Parts list Description	Part No.	Quantity
① Outer fixing block	CFB20.1	N x 2
② Clamping bar	907.881.1.XXX	2
③ Threaded bolt with plate	907.825.2.LLL	2
④ Hexagon nut M8	MAT 0040012	2
⑤ C-profile (part of KMA)	92.42.XXX	1
⑥ Strain relief block	customer-specific	1

 **Order key**  
**907.881.XXX.N**

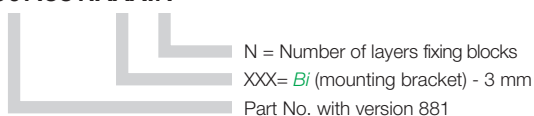

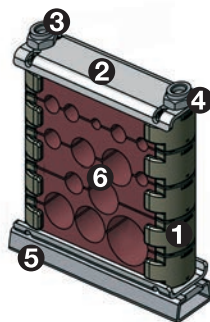

 Please contact igus® for individual designing

**CFB 907.825. | Polymer strain relief connector system**

Parts list Description	Part No.	Quantity
① Outer fixing block	CFB20.1	N x 2
② Clamping bar	907.825.1.XXX	2
③ Threaded bolt with plate	907.825.2.LLL	3
④ Hexagon nut M8	MAT 0040012	3
⑤ C-profile (part of KMA)	92.42.XXX	1
⑥ Strain relief block	customer-specific	1
⑦ Strain relief block	customer-specific	1
⑧ Inner fixing block	CFB20.2	N

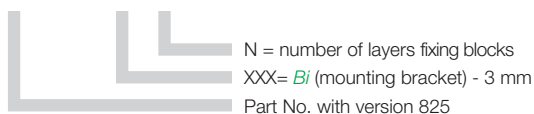
 **Order key**  
**907.825.XXX.N**



 Please contact igus® for individual designing

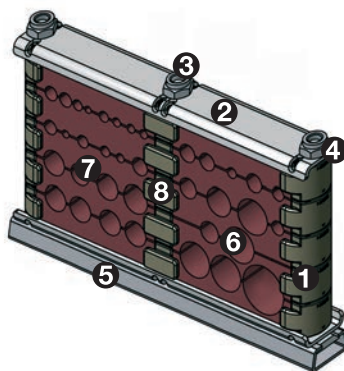

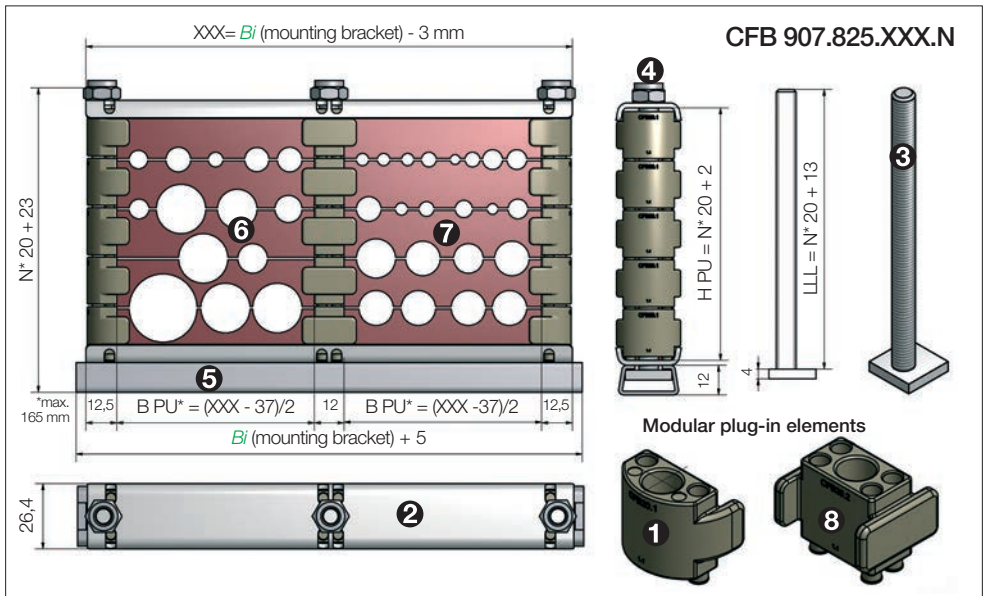
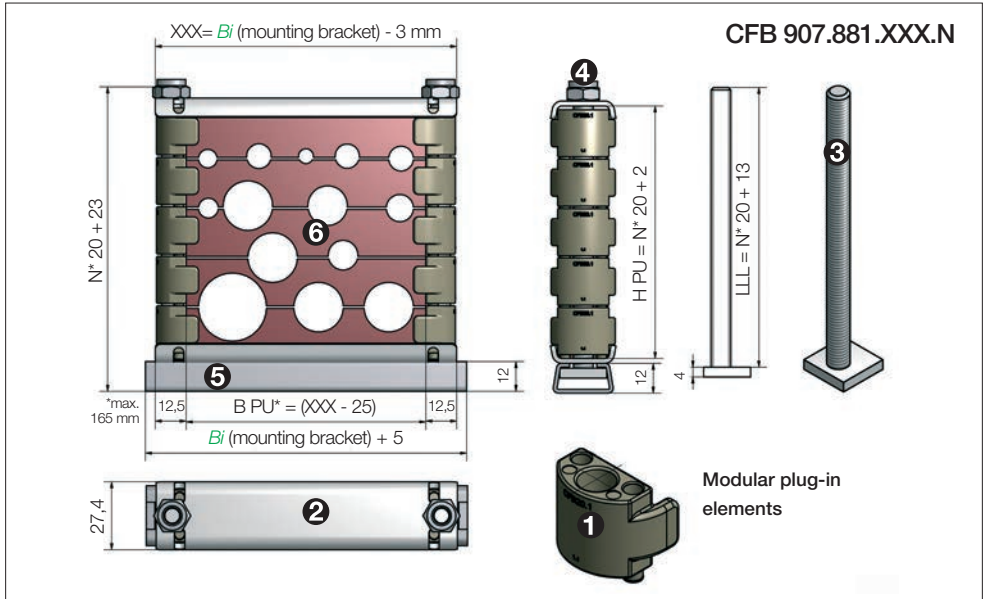

Delivery time upon request, in case of customer-specific fabrication!

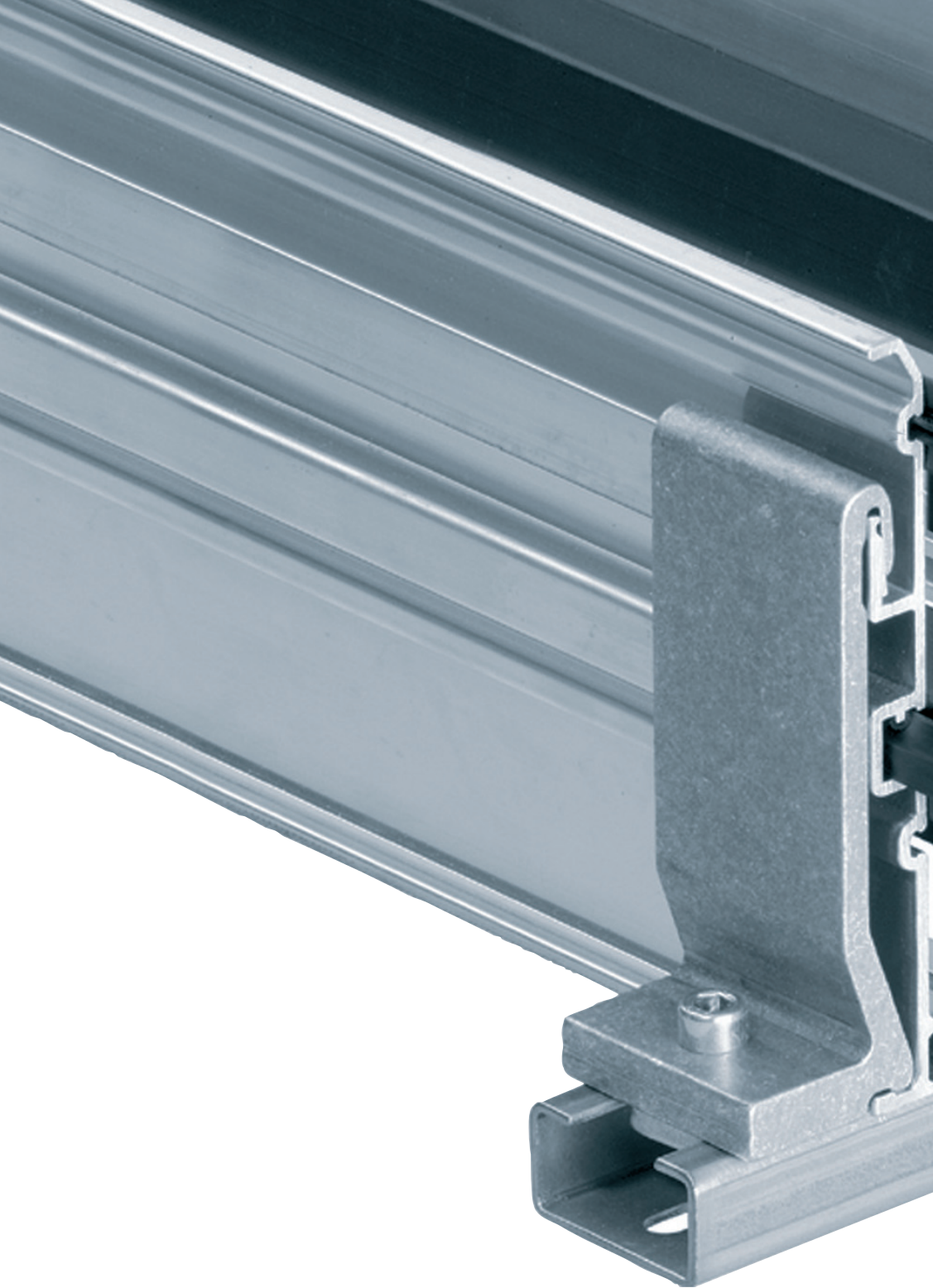

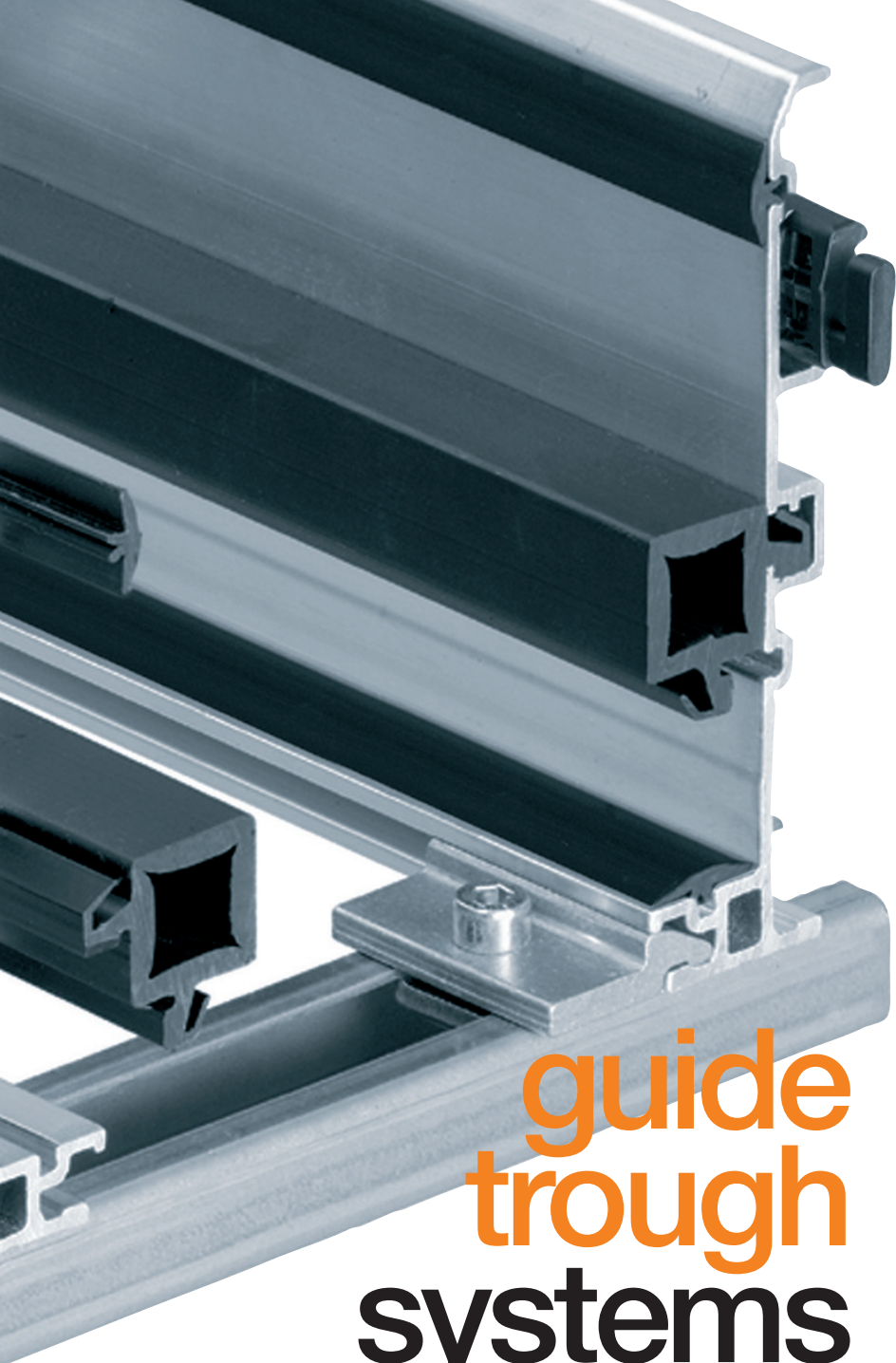

# guide trough systems

aluminum, steel  
and other troughs

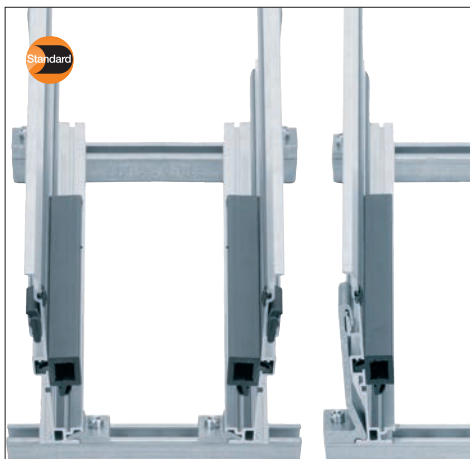

## Aluminum SuperTrough - The igus® standard guide trough

- Huge program available for almost all igus® e-chains®
- Very simple, modular assembly
- Side-mounted glide strips for wear protection in high-speed
- Corrosion resistant, seawater resistant aluminum profile
- Flexible assembly - Fastening on substructure independent of profile lengths and butt joints
- Plastic glide bar made of PE
- Bottom clamp can be mounted -inside or outside- directly on the bottom or on the c-profile
- Heavy duty bracket (add-on item) for high load applications: You can configure the Heavy Duty version at our online-catalog ► [www.igus.eu/eu/salun](http://www.igus.eu/eu/salun)

**The complete range with  
order options ► from page 664**



## Steel guide trough - Very stable and rugged for Heavy-Duty applications

- Very stable and robust guide trough made of steel for high load applications:
- Easy assembly Due to installation set for joint and attachment surface connection
- Simple fastening directly on the ground or with c-profiles
- Big range, two piece design, adjustable to e-chain® width
- Available in galvanized steel and stainless steel
- Low friction: Glide bar made of PE
- Fixed end module (add-on item), for fast and easy mounting - without any drilling available

**The complete range with  
order options ► from page 688**



## Support tray tool kit - For support of the lower run

- Simple one-piece support trays according to your requirements and specification
- Complete system, ready to install
- No more costly self-made designs
- Easy installation onto your machine, on profiles or wall-mount brackets

**The complete range with order options ► from page 714**



## New in this catalog **guidefast guide trough - for crane girders and indoor cranes**

- Save up to 80% installation time compared to standard trough systems
- Fits virtually any standard crane girder
- Simplified installation, permanently installed cables can be fixed at the trough brackets
- Glide bars for middle feed applications

**The complete range with order options ► from page 720**

## **Tubular trough system RS - Lets light and dirt through**

- Resistant to dirt - wear debris falls through
- More open than sheet metal constructions
- Easy and fast assembly and low price
- Easy and space saving delivery

**The complete range with order options ► [www.igus.eu/eu/Tubulartrough](http://www.igus.eu/eu/Tubulartrough)**

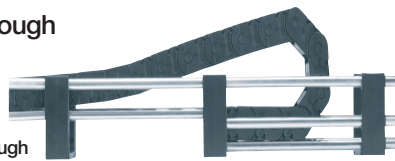

## **Snap-in trough system SP - Simple and cost effective**

- Smaller than conventional troughs
- Easy and fast assembly
- No sharp metal edges in the internal area because of covered connectors
- Low price because of easy assembly

**The complete range with order options ► [www.igus.eu/eu/Snap-in-trough](http://www.igus.eu/eu/Snap-in-trough)**

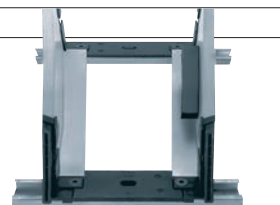

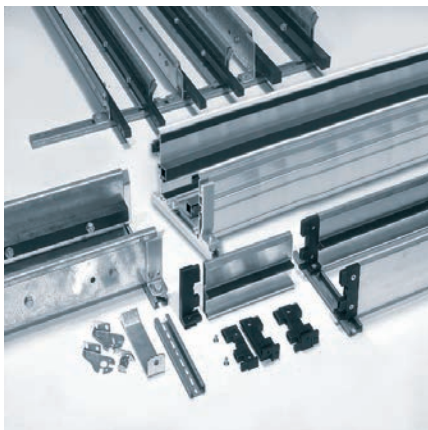

Various guide trough systems are available



igus® troughs delivered from stock

## igus® guide troughs

Guide troughs are used for long travels. They allow to continue smooth, low-friction operation in these long-travel situations.

If the fixed end is installed in the center of the travel ("center-mounted"), the e-chains® glide on themselves for half the travel. For the other half, we recommend glide bars, which are assembled in the trough and on which the e-chains® glide. igus® guide troughs are available from stock with these highly abrasion-resistant polymer glide bars, which perform well with igus® e-chains® regarding noise, abrasion and friction.

## Trough type

igus® offers guide troughs made of corrosion-resistant aluminum, steel or stainless steel. The trough type to be used depends on the application conditions and the requirements of the customer. We recommend the igus® standard Aluminum SuperTrough.

## Glide bars

Glide bars made of igulene are optimally matched to the e-chain® material and achieve the lowest values for friction, noise and wear. Glide bars must be used, if the fixed point is in the center of the travel. It means: Use half of the guide trough with glide bars and the other half of the guide trough without glide bars (see picture in the lower right corner!).

## Delivery condition

The troughs are delivered in 2 meter sections. Special lengths up to 6 m are possible. The left and right side parts are installed on location with the appropriate distance - depending on the width of the e-chain®. The necessary width is shown by the dimension  $B_{RI}$  on the guide trough pages. The e-chain® sides can be linked with the base by screwing, welding or a special igus® installation set. The fixation module for the igus® Aluminum SuperTrough is a quick fix for mounting the stationary end of an e-chain® with a KMA-mounting bracket. With this module a fast and easy mounting onto the Aluminum SuperTrough is possible without any drilling.



Trough without glide bars -  
e-chain® glides on e-chain®

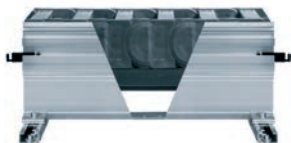

Trough with glide bars -  
e-chain® glides on glide bars



Center mounted: 1/2 Travel with glide  
bars - 1/2 Travel without glide bars

For long travels, the upper run of the igus® e-chains® rests on the lower run. The upper run glides partially on the lower run and partially at the same height on a glide bar. The diagrams below show this. For lateral guidance, a Guide Trough is necessary. If the stationary mounting bracket and the fixed end of the cables and hoses can be placed **in the center**, the e-chain® length is calculated as follows:  $L_k = S/2 + K_2$ . The shortest e-chain® length is attained by the axial feeder module. The length of the e-chain® then corresponds to about half the travel distance. Depending on the technical data and the selected e-chain®, the mounting point of the moving end of the e-chain® must be lowered on some units. In our system analysis for long travels, we give exact details for your specific application.

## Selection criteria

Following parameters are required for the design of a trough system:

- e-chain® type (Series, width  $B_i$ , radius  $R$ )
- Travel and travel speed
- Fill weight
- Acceleration and/or lagging
- Lateral accelerations
- Environmental conditions

## Design and installation of the guide trough

The guide trough is an important element in long travel applications. Usually, the height of the trough must be at least twice that of the e-chain® link height:  $H_{Ri} \geq 2 \times ha$ . The sides must provide a chamfered opening. The trough inner width is the same as the e-chain® outer width, plus 4 mm ( $B_{Ri} = Ba + 4$ ). Along the side of the trough, where the upper run cannot glide on the lower run, glide bars must be installed. We recommend the use of polymer glide bars from igus®. They are optimally matched to the e-chain® material and achieve the lowest values for friction, noise and wear. Guide troughs with and without glide bars can be obtained for almost all igus® e-chains®. **Important: When assembling the trough parts, the following points must be given particular attention:**

- Properly align all trough parts upon installation
- All screw heads should be flush with the trough
- Smooth levelled transition between the end of the e-chain® and the glide bars
- Solid connection with the glide surface. **These points must be observed when using assembly-friendly igus® guide troughs.**

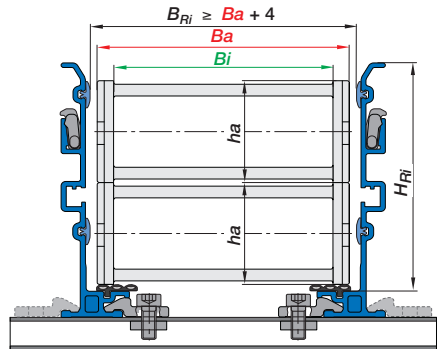

Aluminum SuperTrough without glide bars - upper run glides on the lower run

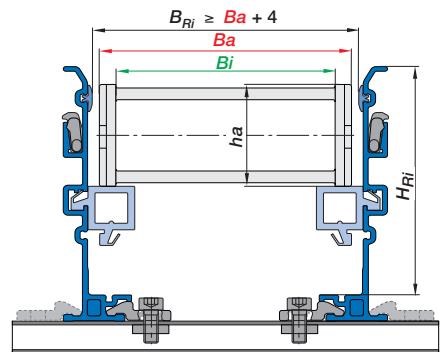

Aluminum SuperTrough with glide bars - From the middle of the travel the upper run glides off on the glide bar

e-chain® length

$$L_k = S/2 + K_2$$

Inner trough height

$$H_{Ri} \geq 2 \times ha$$

Inner width, Alu SuperTrough  $B_{Ri} \geq Ba + 4$

( $Ba + 5$  Steel guide trough)

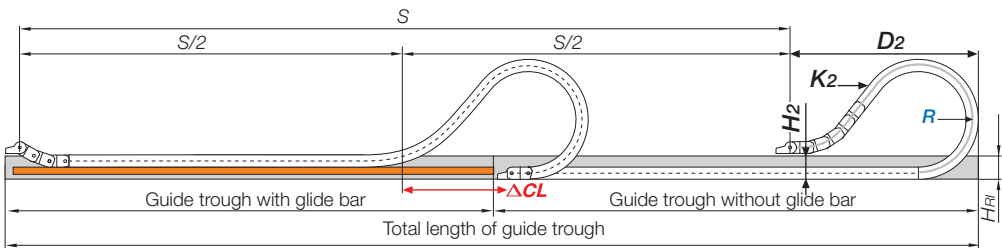

- |  |                    |                                  |                               |                                |  |
|--|--------------------|----------------------------------|-------------------------------|--------------------------------|--|
|  | ● Trough set       | $Ba$ = Outer width e-chains®     | $S$ = Length of travel        | $H_{Ri}$ = Inner trough height | $H_2$ = Mounting height (if the moving end is set lower) |
|  | ● Installation set | $Bi$ = Inner width e-chains®     | $S/2$ = Half length of travel | $H_{Ra}$ = Outer trough height | $D_2$ = Over length - long travels, gliding              |
|  | ● Glide bar        | $R$ = Bending radius             | $B_{Ri}$ = Inner trough width | $ha$ = Outer e-chain® height   | $K_2$ = Further add-on (if the moving end is set lower)  |
|  | ● C-Profile        | $\Delta CL$ = Offset fixed point | $B_{Ra}$ = Outer trough width | $L_k$ = e-chain® length        | $H_e$ = Required clearance height                        |



# Guide Troughs | Long travels | C-profiles

## C-profiles Part No. 92.52.XX

- For all igus® Aluminum SuperTrough and Steel guide troughs
- With increased holding power - even for harsh applications
- Standard material: galvanized steel

**Part No. 92.52.XX** (XX - length in mm)

- C-profile available in galvanized steel. Optional:  
Stainless steel material V2A, material 1.4301 (AISI 304).  
For AISI 304 please add index "E" to the **Part No. 92.52.E**
- Length tolerances of  $\pm 5$  mm possible!

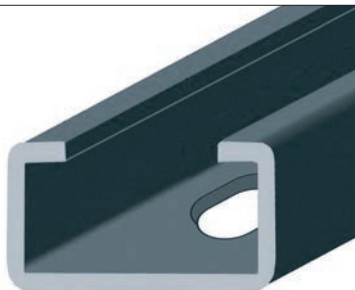

## C-profile Part No. 92.52.XX | With increased holding power also for harsh conditions

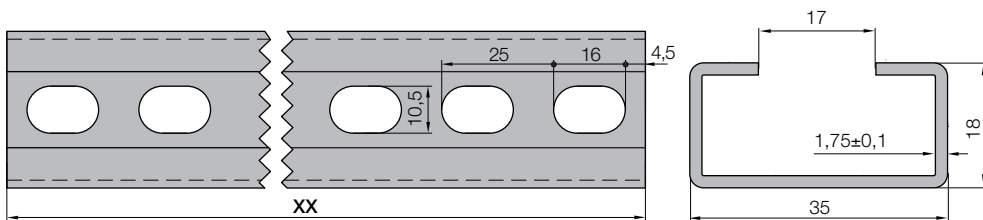

C-profiles Part No. 92.52.XX - For all igus® Aluminum SuperTrough and Steel guide troughs

## Tubular trough system RS - Lets light and dirt through

- Resistant to dirt - wear debris falls through
- More open than sheet metal constructions
- Easy and fast assembly and low price
- Easy and space saving delivery

The complete range with order options ► [www.igus.eu/eu/Tubulartrough](http://www.igus.eu/eu/Tubulartrough)

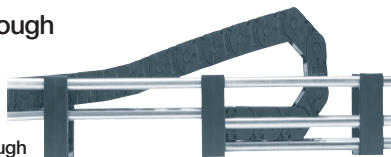

## Snap-in trough system SP - Simple and cost effective

- Smaller than conventional troughs
- Easy and fast assembly
- No sharp metal edges in the internal area because of covered connectors
- Low price because of easy assembly

The complete range with order options ► [www.igus.eu/eu/Snap-in-trough](http://www.igus.eu/eu/Snap-in-trough)

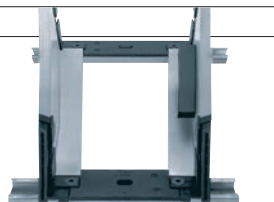

## Aluminum SuperTrough - The igus® standard guide trough

- Very simple, modular assembly
- Side-mounted glide strips for wear protection in high-speed
- Corrosion resistant, seawater resistant aluminum profile
- Flexible assembly - Fastening on substructure independent of profile lengths and butt joints
- Plastic glide bar made of PE
- Bottom clamp can be mounted -inside or outside- directly on the bottom or on the c-profile

The complete range with order options ▶ from page 664



## Steel guide trough - Very stable and rugged for Heavy-Duty applications

- Very stable and robust guide trough made of steel
- Easy assembly with installation set
- Big range, two piece design, adjustable to e-chain® width
- Available in galvanized steel and stainless steel
- Glide bar made of PE

The complete range with order options ▶ from page 688



## Support tray tool kit - For support of the lower run

- Simple one-piece support trays according to your requirements and specification
- Complete system, ready to install
- No more costly self-made designs
- Easy installation onto your machine, on profiles or wall-mount brackets

The complete range with order options ▶ from page 714



## New in this catalog guidefast - for crane girders

- Save up to 80% installation time compared to standard trough systems
- Fits virtually any standard crane girder
- Simplified installation, permanently installed cables
- With polymer glide bars for centre fed applications

The complete range with order options ▶ from page 720



# Aluminum SuperTrough | Introduction | Advantages

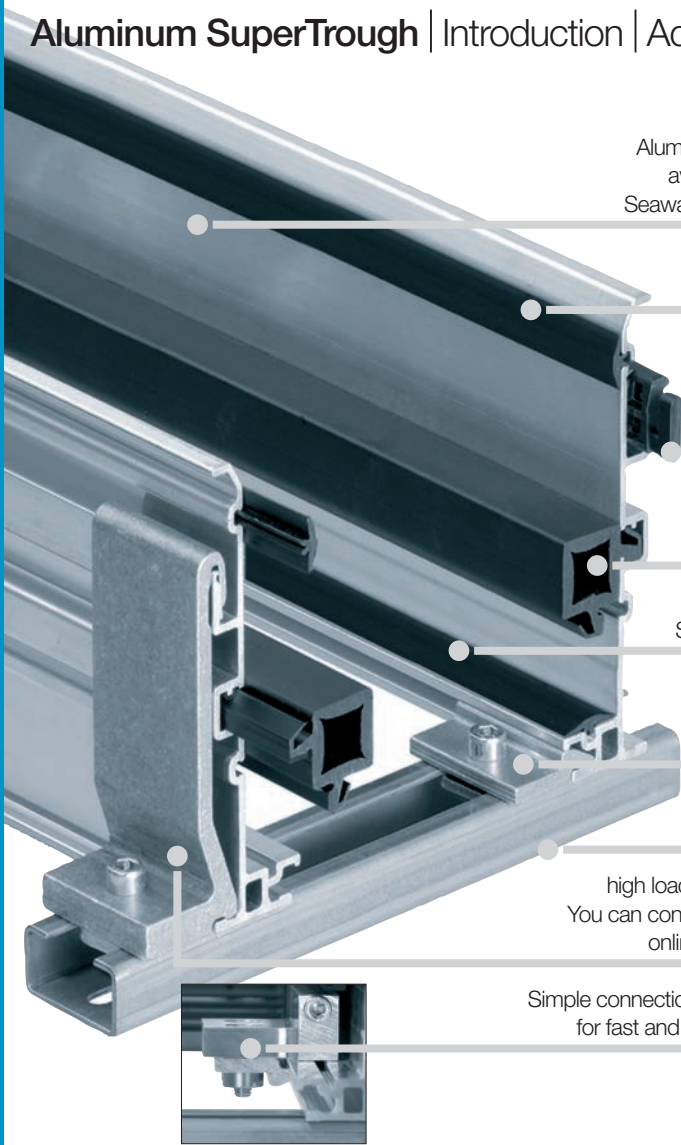

Huge program:  
Aluminum profile (Standard: 2 m section)  
available for almost all igus® e-chains®  
Seawater resistant and corrosion resistant

Wear-reducing: Glide strip  
Protect from wear on the sides

Fast connection:  
Interface connector Basic,  
polymer, easy assembly,  
no tools needed

Wear-reducing  
Polymer glide bar  
Easy click-on assembly

Noise-reducing:  
Silencer profile, rubber (add-on item)

Simple fastening: Bottom  
clamp Basic, attached inwards  
or outwards, fast and easy

Simple fastening: C-profile,  
for bottom clamps

high load: Heavy duty bracket (add-on item)  
You can configure the Heavy Duty version at our  
online-catalog ► [www.igus.eu/eu/salun](http://www.igus.eu/eu/salun)

Simple connection: Fixed end module (add-on item),  
for fast and easy mounting - without any drilling

## Aluminum SuperTrough | The igus® standard

The Aluminum SuperTrough is a modular guide trough system for long travels (gliding application). Aluminum SuperTrough is available in low cost basic versions and can be upgraded for heavy duty applications. This modular usage makes it the igus® recommended standard trough system.

- Very simple, modular assembly
- Corrosion resistant, seawater resistant aluminum profile
- Flexible assembly - Fastening on substructure independent of profile lengths and butt joints
- Misalignment-free installation - No screwing or welding of the profiles required

Installation Guide-PDF with detailed assembly information ► [www.igus.eu/eu/installation-guide-pdf](http://www.igus.eu/eu/installation-guide-pdf)





Series Part No.	Outer trough height $H_{Ra}$ (mm)	Installation set* Part No.	Side part material	Page
				
970.30.SL   970.31.SL	77	960.30	aluminum	670
970.30.SL   970.32.SL	77	960.30	aluminum	672
971.30.SL   971.31.SL	87	960.30	aluminum	674
972.02.30.SL   972.02.31.SL	117	960.30	aluminum	676
972.30.SL   972.31.SL	117	960.30	aluminum	678
972.30.SL   972.32.SL	117	960.30	aluminum	680
973.30.SL   973.31.SL	144	960.50	aluminum	682
974.30.SL   974.31.SL	184	960.50	aluminum	684
975.30.SL   975.31.SL	236	960.50	aluminum	686

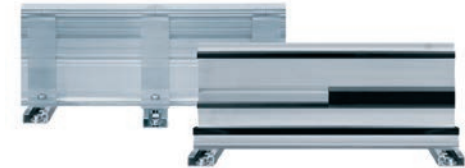

### Heavy Duty version - for rugged plant construction

You can configure the Heavy Duty version online with the respective e-chain\* you've chosen or ► [www.igus.eu/eu/salun](http://www.igus.eu/eu/salun)

971.30.SL   971.31.SL	87	971.50	aluminum	<a href="http://www.igus.eu/eu/salun">www.igus.eu/eu/salun</a>
972.02.30.SL   972.02.31.SL	117	972.50	aluminum	<a href="http://www.igus.eu/eu/salun">www.igus.eu/eu/salun</a>
972.30.SL   972.31.SL	117	972.50	aluminum	<a href="http://www.igus.eu/eu/salun">www.igus.eu/eu/salun</a>
972.30.SL   972.32.SL	117	972.50	aluminum	<a href="http://www.igus.eu/eu/salun">www.igus.eu/eu/salun</a>
973.30.SL   973.31.SL	144	973.50	aluminum	<a href="http://www.igus.eu/eu/salun">www.igus.eu/eu/salun</a>
974.30.SL   974.31.SL	184	974.50	aluminum	<a href="http://www.igus.eu/eu/salun">www.igus.eu/eu/salun</a>
975.30.SL   975.31.SL	236	975.50	aluminum	<a href="http://www.igus.eu/eu/salun">www.igus.eu/eu/salun</a>

\*The basic Installation sets are the standard for the Aluminum SuperTroughs. They can be fastened inside or outside and are recommended for most application areas. The basic clamping shoes are made of aluminum. The Heavy Duty version is differentiated only by the type of the installation set. The part numbers of the channel side plates, slide bars, etc., are the same as the basic model. The Heavy Duty installation set consists of a rugged aluminum bracket, fastened outside on the guide trough.

## Aluminum SuperTrough | Sizes Overview

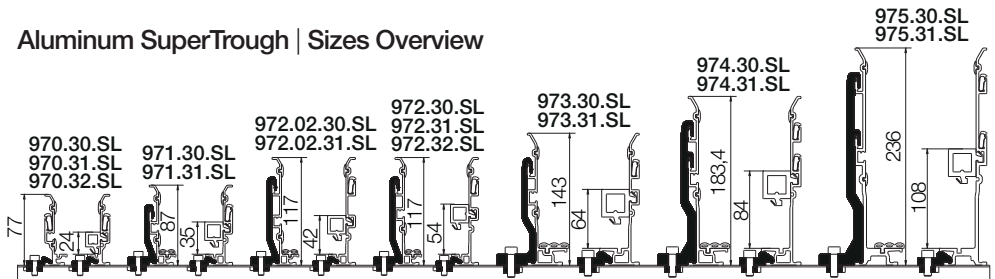

# Aluminum SuperTrough | Basic | Parts

## Components, trough

- 1 Trough side parts, aluminum, 2 m
- 2 Glide bar, plastic, 2 m
- 3 Glide strips, plastic, 2 m  
(without glide strips on request)
- 4 Optional: Silencer profile, rubber

## Components, installation set

- A Bottom clamp, aluminum
- B C-profile<sup>1)</sup>, galvanized steel
- C Screw
- D Sliding nut
- E Interface connector, plastic

- $Ba$  = Outer e-chain® width
- $Bi$  = Inner e-chain® width
- $ha$  = e-chain® outer height
- $H_{Ri}$  = Inner trough height
- $H_{Ra}$  = Outer trough height
- $B_{Ri}$  = Inner trough width
- $B_{Ra}$  = Outer trough width

$H_{Ri} \geq 2 \times ha$

$B_{Ri} \geq Ba + 4$

1) C-profile also available in stainless steel V2A, material 1.4301 (AISI 304)

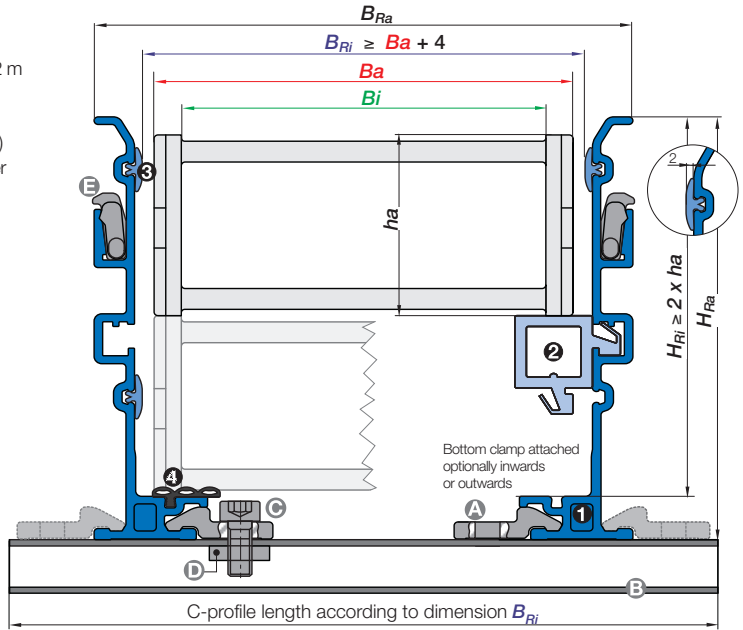

## Aluminum SuperTrough | Features

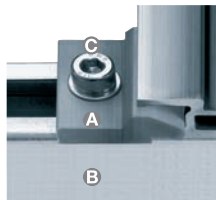
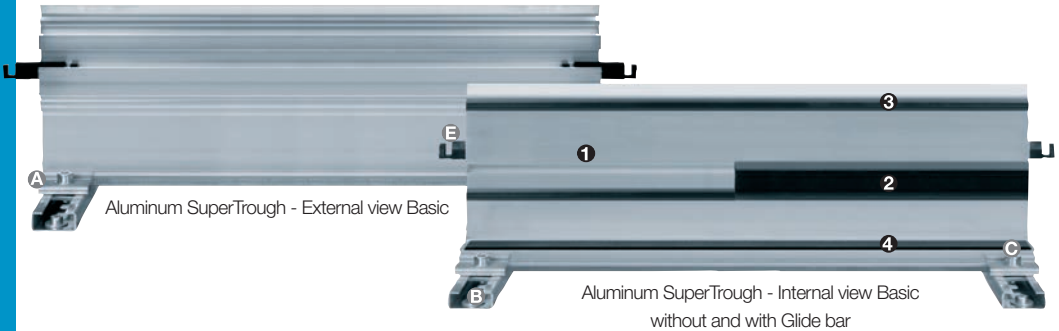

Simple fastening with Basic bottom clamp and C-profile

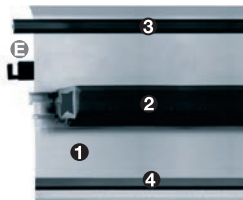

Wear-reducing with polymer glide bar and glide strip



Noise-reducing with silencer profile (add-on item)

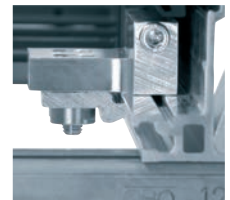

Simple connection to the e-chain® with the Fixed end module



## Aluminum SuperTrough | Configuration according to your requirements

### Quick and easy assemble the right trough for your application

- Selection of the suitable guide trough according to the e-chain® Series and e-chain® width  $B_i$
- Determine the feeding point of the cables
- Determine travel distance and thus the length of the required guide trough and the number of trough pieces. (Standard length of a trough side plate: 2000 mm). The length of the guide trough - for axial feeding - is calculated from half the travel length with and half the travel length without the glide bar
- Option: "Sound dampening" with silencer profile
- Number and selection of the assembly kit

There are two assembly kit options: Basic (standard), heavy duty (for plant construction)

**The quantity of the assembly kit is calculated from the number of the trough pieces + 1 kit:**

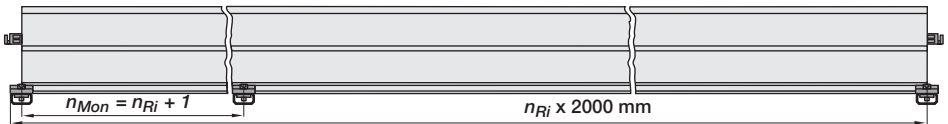

- The assembly kit matches the igus c-profile option
- If you have opted for an e-chain® with KMA mounting brackets, we offer you a fixed-end module for the quick and simple fastening of the e-chain® in the trough without holes

### Installation Guide-PDF with detailed assembly information

► [www.igus.eu/eu/installation-guide-pdf](http://www.igus.eu/eu/installation-guide-pdf)

## Order example | Based on Part No. 973.30.SL | 973.31.SL



**Order example: Length of travel 30 m - Center mounted for Series 3500.100.200.0 with  $B_{Ri} = 124$**

Guide trough set (set of 2 trough side parts, incl. glide strips) **without** glide bar

**Order text: 16 m guide trough without glide bar (8 x 2 m sections)**

**Part No. 973.30.SL**

Guide trough set (set of 2 trough side parts, incl. glide strips) **with** glide bar

**Order text: 16 m guide trough with glide bar (8 x 2 m sections)**

**Part No. 973.31.SL**

Installation set "Basic" complete (guide trough-sets + 1)

**Order text: 17 installation sets "Basic"**

**Part No. 960.50.175**

Module for the fixed end

**Order text: 1 set**

**Part No. 973.80**

**Option:** For an additional noise dampening with silencer profile, please add Index A Example:

**Part No. 973.30.SLA**



**Calculation - travel center mounted:** Half travel length, rounded down to full 2 m sections = X m guide trough length without glide bars + X m guide trough length with glide bars + installation sets Basic (number of trough pieces + 1)

# Aluminum SuperTrough | Basic | Fixed end module / clamp

## Fixed end module | Quick and simple fastening onto the Aluminum SuperTrough

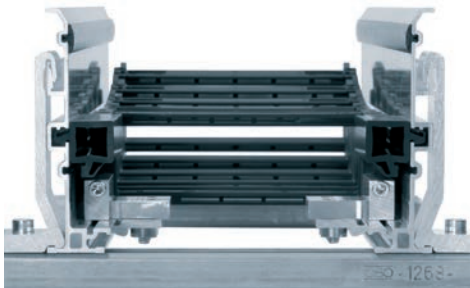

### A quick fix for mounting the stationary end of an e-chain®

With this module for the fixed end, fast and easy mounting onto the Aluminum SuperTrough is now possible without any drilling. Fast mounting of the e-chain® by clamping onto the alu trough

● Quick relocation of the stationary end ● No drilling necessary  
**Installation - A) Fixed-end module, B) KMA mounting bracket**

❶ Removing the preassembled metal bushings ❷ Use of threaded bushings ❸ Installation fixed-end module ❹ Mounting on Aluminum SuperTrough

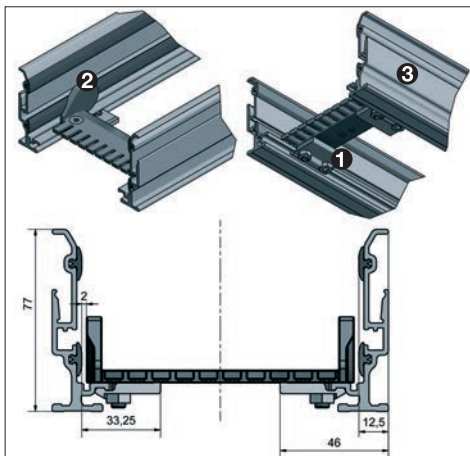
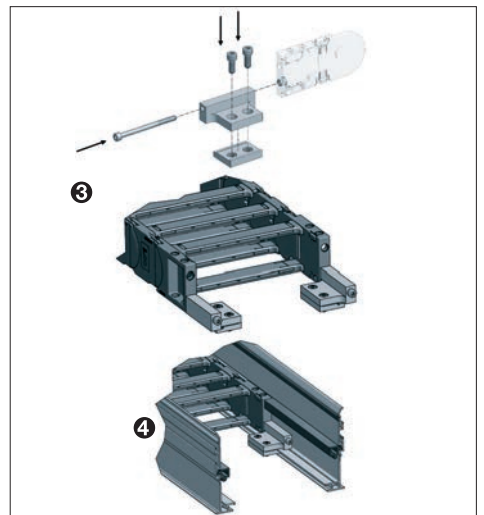
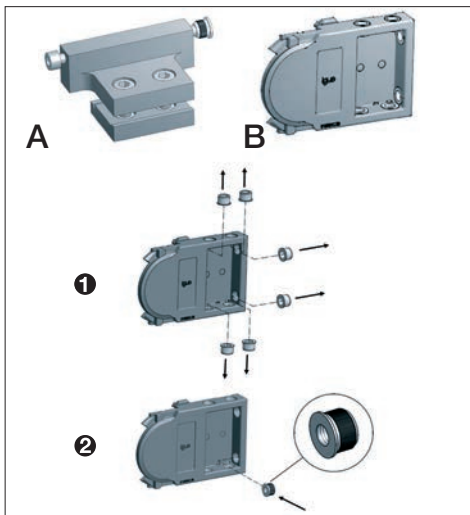

### Fixed end clamp to attach the e-chain® into the smallest Aluminum SuperTrough 970.30.SL

For mounting brackets from series: 10, 15/R15, B15, 1500. The fixed end clamp enables quick and simple attachment by clamping onto the Aluminum SuperTrough without drilling.

● Quick attachment of the e-chain® to the Aluminum SuperTrough  
● The mounting point of the e-chain® can be changed quickly

**Fixed end clamp principle:**

- ❶ Fixed end clamp 970.80
- ❷ Mounting bracket
- ❸ Aluminum SuperTrough 970.30.SL



## Fixed end module | Fixed end clamp | Delivery program

Part No.	For Aluminum SuperTrough	For e-chain® Series	Application including inner width (B)	Mounting Bracket
970.80	970.30.SL   970.31.SL	10, B15, 15/R15	(Fixed end clamp) .050	one-piece
970.80	970.30.SL   970.32.SL	1500	(Fixed end clamp) .050	one-piece
971.80	971.30.SL   971.31.SL	2500, 255	.07	KMA
972.82	972.02.30.SL   972.02.31.SL	E4.28/R4.28, E6.35	.06	KMA
972.80	972.30.SL   972.31.SL	E4.32/H4.32/R4.32, E4.38L, E6.40/R6.40	.06	KMA
972.81	972.30.SL   972.32.SL	2700, R58	.06	KMA
973.81	973.30.SL   973.31.SL	E4.42/H4.42/R4.42, E4.48L, E6.52/R6.52		KMA
973.80	973.30.SL   973.31.SL	3500, R68	.100	KMA
974.81	974.30.SL   974.31.SL	14040/14140/R18840, 14240/14340	.10	KMA
974.80	974.30.SL   974.31.SL	E4.56/H4.56/R4.56, E6.62	.10	KMA
975.80	975.30.SL   975.31.SL	E4.80/H4.80/R4.80, E6.80	.10	KMA
975.81	975.30.SL   975.31.SL	15050/15150/R19850, 15250/15350	.10	KMA

Assembly kits material: Aluminum AlMg3, seawater resistant. Material screw kits: Standard steel, galvanized. Also available in stainless steel 1.4571 as an option: e.g. 974.80.E4

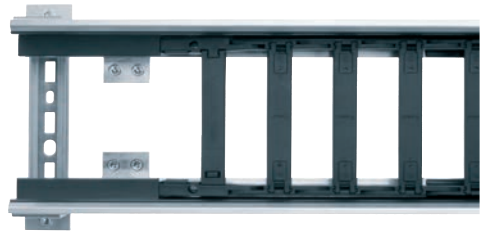
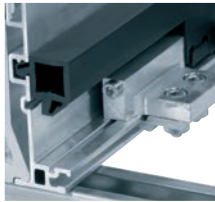

Fixed-end module - Simple fastening of the e-chain® without drilling

## Aluminum SuperTrough | Test examples



The igus® Aluminum SuperTrough has been used in test setups since 2005.

Test setup Axis 1: Speed 1.5 m/s, Travel: 18 m, Mileage so far: about 50,000 km (test runs since 2005)





# C-profile lengths (according to dim. $B_{Ri}$ ) | Basic Version

## Bottom clamp attached optionally inwards or outwards



970.30.SL  
970.31.SL

10				B15				15				R15			
Width index e-chain® [mm]	$B_{Ri}$	Part No. attached inwards	Part No. attached outwards	Width index e-chain® [mm]	$B_{Ri}$	Part No. attached inwards	Part No. attached outwards	Width index e-chain® [mm]	$B_{Ri}$	Part No. attached inwards	Part No. attached outwards	Width index e-chain® [mm]	$B_{Ri}$	Part No. attached inwards	Part No. attached outwards
.015	30	upon request	960.30.125	.015	30	upon request	960.30.125	.015	30	upon request	960.30.125	.025	40	upon request	960.30.150
.025	40	upon request	960.30.150	.025	40	upon request	960.30.150	.025	40	upon request	960.30.150	.038	80	upon request	960.30.150
.038	53	upon request	960.30.150	.038	53	upon request	960.30.150	.038	53	upon request	960.30.150	.063	80	upon request	960.30.175
.050	65	960.30.125	960.30.175	.050	65	960.30.125	960.30.175	.050	65	960.30.175	960.30.175	.080	98	960.30.150	960.30.200
.5	80	960.30.125	960.30.175	.5	80	960.30.125	960.30.175	.5	80	960.30.175	960.30.175				
.6	98	960.30.150	960.30.200	.6	98	960.30.150	960.30.200	.6	98	960.30.200	960.30.200				
.7	117	960.30.175	960.30.225	.7	117	960.30.175	960.30.225	.7	117	960.30.225	960.30.225				

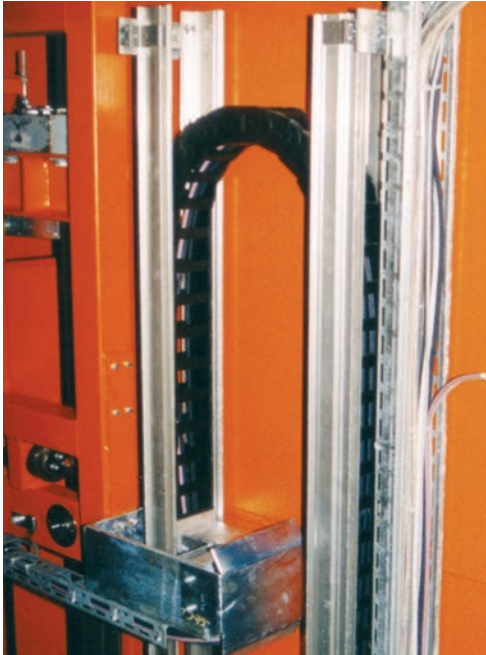

e-chain® on the tower of the storage and retrieval unit for high-bay warehouses rolls off from one aluminum guide trough to the opposite one



For the following  
igus® Series

E2/000

● 1500

E4.1

● E4.21

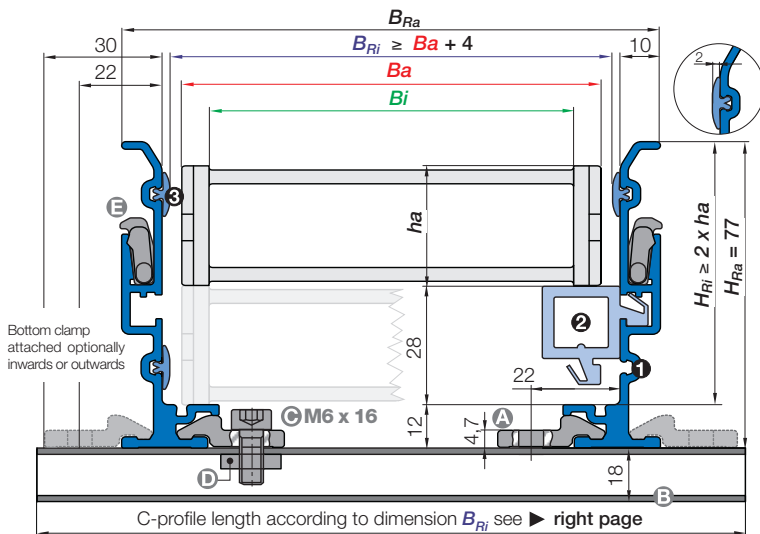

**Note:** The inner width of the guide trough and the C-profile length of the assembly kit can differ according to the bracket you choose. Please call us!

## Aluminum SuperTrough | Complete sets

Trough side parts sets - consisting of part ① / ② / ③	Part No.	Weight
Set of 2 trough side parts, incl. glide strips, <b>without</b> glide bars, 2 m section	970.30.SL	≈ 4,20 kg
Set of 2 trough side parts, incl. glide strips, <b>with</b> glide bars, 2 m section	970.32.SL	≈ 5,00 kg

### Installation sets - consisting of part A / B / C / D / E

1 Installation set <b>without</b> C-profile	960.30	≈ 0,06 kg
1 Installation set <b>with</b> C-profile (C-profile length according to dimension $B_{Ri}$ )	960.30.XXX*	upon request

\* Please add the C-profile length as shown on the tables on the right page. Example: 960.30.125

## Aluminum SuperTrough | Components as single parts

Single parts, trough	Part No.	Weight
① 1 Trough side part, individual, 2 m section	70.30	≈ 2,04 kg
② 1 Glide bar, plastic, individual, 2 m section	81.79	≈ 0,42 kg
③ 1 Glide strip, plastic, individual, 2 m section	75.01	≈ 0,06 kg
Single parts, installation set		
A 1 Bottom clamp, aluminum individual	75.40	≈ 0,03 kg
B 1 C-profile, individual (C-profile length according to dimension $B_{Ri}$ )	92.52.XXX.E*	≈ 0,90 kg/m
C 1 Screw M6 x 16, individual	MAT 0040209	
D 1 Sliding nut M6, individual	MAT 0040057	
E 1 Interface connector, individual	75.60	

### Additional option for simple fastening of the e-chain® without drilling

1 Set Fixed end clamp (not for E4.21. Detailed information ► page 668)	970.80
--	--------

\* Please add the C-profile length as shown on the tables on the right page. Example: 92.52.125.E

C-profile also available in stainless steel V2A, material 1.4301 (AISI 304). Please add index "E" to the Part No.

# C-profile lengths (according to dim. $B_{Ri}$ ) | Basic Version

Bottom clamp attached optionally inwards or outwards



970.30.SL  
970.32.SL

1500				E4.21			
Width index e-chain*	$B_{Ri}$ [mm]	Part No. attached inwards	Part No. attached outwards	Width index e-chain*	$B_{Ri}$ [mm]	Part No. attached inwards	Part No. attached outwards
.015	33	upon request	960.30.125	.030	48	upon request	960.30.150
.020	38	upon request	960.30.125	.040	58	960.30.125	960.30.150
.025	43	upon request	960.30.150	.050	68	960.30.125	960.30.175
.038	56	upon request	960.30.150	.060	78	960.30.125	960.30.175
.050	68	960.30.125	960.30.175	.070	88	960.30.150	960.30.175
.068	86	960.30.150	960.30.175	.080	98	960.30.150	960.30.200
.080	98	960.30.150	960.30.200	.090	108	960.30.175	960.30.200
.100	118	960.30.175	960.30.225	.100	118	960.30.175	960.30.225
.125	143	960.30.200	960.30.250	.110	128	960.30.175	960.30.225
				.120	138	960.30.200	960.30.225
				.140	158	960.30.225	960.30.250



Seawater resistant Aluminum SuperTrough in a RTG-crane. Long travel with igus® E4 system



For the following  
igus® Series

## E2/000

- 2500
- 255

## E2 e-tubes

- R48

## E6

- E6.29/R6.29

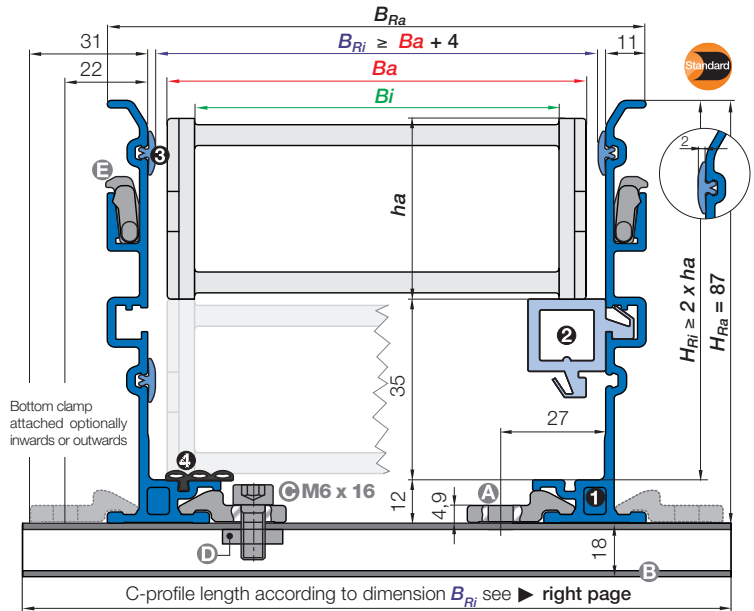

**Note:** The inner width of the guide through and the C-profile length of the assembly kit can differ according to the bracket you choose. Please call us!

## Aluminum SuperTrough | Complete sets

Trough side parts - consisting of part 1 / 2 / 3 / 4	Part No.	Weight
Set of 2 trough side parts, incl. glide strips, <b>without</b> glide bars, 2 m section	971.30.SLA**	≈ 5,00 kg
Set of 2 trough side parts, incl. glide strips, <b>with</b> glide bars, 2 m section	971.31.SLA**	≈ 6,40 kg

\*\* For an additional noise dampening with silencer profile, please add index "A" to the Part No. Example: 971.30.SLA

Installation sets - consisting of part A / B / C / D / E	Part No.	Weight
1 Installation set <b>without</b> C-profile	960.30	≈ 0,06 kg
1 Installation set <b>with</b> C-profile (C-profile length according to dimension B <sub>Rl</sub> )	960.30.XXX*	upon request

\* Please add the C-profile length as shown on the tables on the right page. Example: 960.30.150

## Aluminum SuperTrough | Components as single parts

Single parts, trough	Part No.	Weight
1 1 Trough side part, individual, 2 m section	71.30	≈ 2,44 kg
2 1 Glide bar, plastic, individual, 2 m section	82.79	≈ 0,6 kg
3 1 Glide strip, plastic, individual, 2 m section	75.01	≈ 0,06 kg
4 1 Silencer profile, rubber, individual, 2 m section (optional for an additional noise dampening)	75.67.H	≈ 0,16 kg
Single parts, installation set		
A 1 Bottom clamp, aluminum individual	75.40	≈ 0,03 kg
B 1 C-profile, individual (C-profile length according to dimension B <sub>Rl</sub> )	92.52.XXX.E*	≈ 0,90 kg/m
C 1 Screw M6 x 16, individual	MAT 0040209	
D 1 Sliding nut M6, individual	MAT 0040057	
E 1 Interface connector, individual	75.60	

Additional option for simple fastening of the e-chain® without drilling	Part No.
1 Set Fixed end module (not for R48, E6.29/R6.29. Detailed information ▶ page 668)	971.80

\* Please add the C-profile length as shown on the tables on the right page. Example: 92.52.125.E

C-profile also available in stainless steel V2A, material 1.4301 (AISI 304). Please add index "E" to the Part No.

# C-profile lengths (according to dim. $B_{Ri}$ ) | Basic Version



971.30.SL  
971.31.SL

Bottom clamp attached optionally inwards or outwards

2500				255				E6.29/R6.29				R48			
Width index e-chain* [mm]	$B_{Ri}$	Part No. attached inwards	Part No. attached outwards	Width index e-chain* [mm]	$B_{Ri}$	Part No. attached inwards	Part No. attached outwards	Width index e-chain* [mm]	$B_{Ri}$	Part No. attached inwards	Part No. attached outwards	Width index e-chain* [mm]	$B_{Ri}$	Part No. attached inwards	Part No. attached outwards
.02	45	upon request	960.30.150	.03	58	upon request	960.30.150	.030	50	upon request	960.30.150	.025	40	upon request	960.30.150
.03	58	upon request	960.30.150	.05	77	960.30.125	960.30.175	.040	60	upon request	960.30.175	.050	65	upon request	960.30.175
.05	77	960.30.125	960.30.175	.07	97	960.30.150	960.30.200	.050	70	upon request	960.30.175	.075	90	960.30.150	960.30.200
.07	97	960.30.150	960.30.200	.10	123	960.30.175	960.30.225	.060	80	960.30.150	960.30.175	.100	115	960.30.175	960.30.225
.09	109	960.30.175	960.30.225					.070	90	960.30.150	960.30.200	.130	145	960.30.200	960.30.250
.10	123	960.30.175	960.30.225					.080	100	960.30.150	960.30.200				
.12	145	960.30.200	960.30.250					.090	110	960.30.175	960.30.225				
								.100	120	960.30.175	960.30.225				
								.110	130	960.30.200	960.30.225				
								.120	140	960.30.200	960.30.250				



Series E4 in a seawater-resistant aluminum guide trough

## Heavy Duty version for high load applications

This Aluminum SuperTrough is also available for plant manufacturing as add-on item with special heavy duty brackets for safe connection: **Installation set Part No. 971.50**. You can configure the heavy duty version at our online-catalog with the respective e-chain\* you've chosen. **Further general information about the Aluminum SuperTrough** ► [www.igus.eu/salun](http://www.igus.eu/salun)

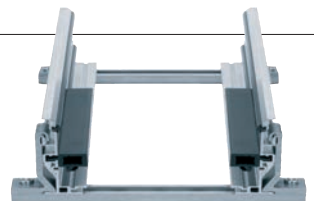



For the following  
igus® Series

E4.1

● E4.28/R4.28

E6

● E6.35

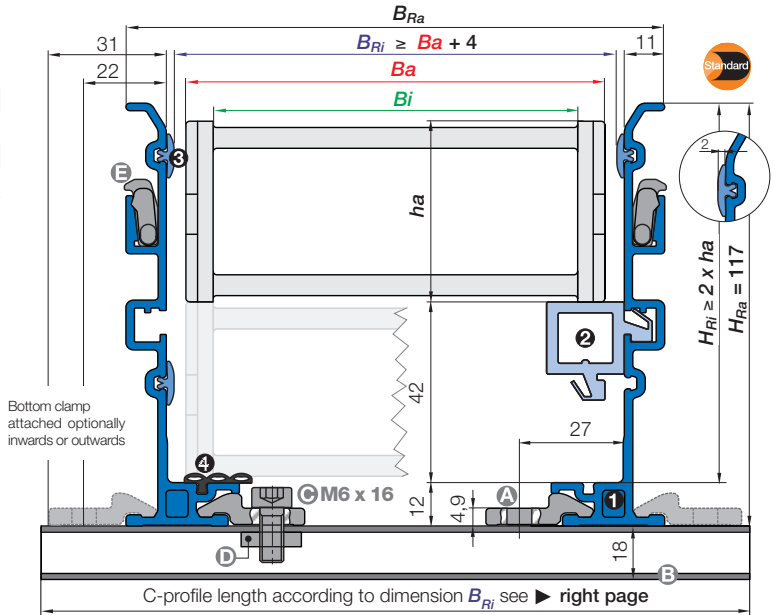

**Note:** The inner width of the guide through and the C-profile length of the assembly kit can differ according to the bracket you choose. Please call us!

## Aluminum SuperTrough | Complete sets

Trough side parts sets - consisting of part 1 / 2 / 3 / 4	Part No.	Weight
Set of 2 trough side parts, incl. glide strips, <b>without</b> glide bars, 2 m section	972.02.30.SLA**	≈ 6,00 kg
Set of 2 trough side parts, incl. glide strips, <b>with</b> glide bars, 2 m section	972.02.31.SLA**	≈ 7,40 kg

\*\* For an additional noise dampening with silencer profile, please add index "A" to the Part No. Example: 972.02.30.SLA

Installation sets - consisting of part A / B / C / D / E	Part No.	Weight
1 Installation set <b>without</b> C-profile	960.30	≈ 0,06 kg
1 Installation set <b>with</b> C-profile (C-profile length according to dimension $B_{Ri}$ )	960.30.XXX*	upon request

\* Please add the C-profile length as shown on the tables on the right page. Example: 960.30.175

## Aluminum SuperTrough | Components as single parts

Single parts, trough	Part No.	Weight
1 1 Trough side part, individual, 2 m section	72.02.30	≈ 2,94 kg
2 1 Glide bar, plastic, individual, 2 m section	82.79	≈ 1,30 kg
3 1 Glide strip, plastic, individual, 2 m section	75.01	≈ 0,06 kg
4 1 Silencer profile, rubber, individual, 2 m section (optional for an additional noise dampening)	75.67.H	≈ 0,16 kg

Single parts, installation set	Part No.	Weight
A 1 Bottom clamp, aluminum individual	75.40	≈ 0,03 kg
B 1 C-profile, individual (C-profile length according to dimension $B_{Ri}$ )	92.52.XXX.E*	≈ 0,90 kg/m
C 1 Screw M6 x 16, individual	MAT 0040209	
D 1 Sliding nut M6, individual	MAT 0040057	
E 1 Interface connector, individual	75.60	

### Additional option for simple fastening of the e-chain® without drilling

1 Set Fixed end module (Detailed information ► page 668)	972.82
--	--------

\* Please add the C-profile length as shown on the tables on the right page. Example: 92.52.125.E

C-profile also available in stainless steel V2A, material 1.4301 (AISI 304). Please add index "E" to the Part No.

# C-profile lengths (according to dim. $B_{Ri}$ ) | Basic Version

Bottom clamp attached optionally inwards or outwards



972.02.30.SL  
972.02.31.SL

E4.28/R4.28				E6.35			
Width index e-chain* [mm]	$B_{Ri}$	Part No. attached inwards	Part No. attached outwards	Width index e-chain* [mm]	$B_{Ri}$	Part No. attached inwards	Part No. attached outwards
.040	64	upon request	960.30.175	.030	54	upon request	960.30.150
.050	74	960.30.125	960.30.175	.040	64	upon request	960.30.175
.062	86	960.30.150	960.30.200	.050	74	960.30.125	960.30.175
.070	94	960.30.150	960.30.200	.060	84	960.30.150	960.30.200
.075	99	960.30.150	960.30.200	.070	94	960.30.150	960.30.200
.087	111	960.30.175	960.30.225	.080	104	960.30.150	960.30.200
.100	124	960.30.175	960.30.225	.090	114	960.30.175	960.30.225
.125	149	960.30.200	960.30.250	.100	124	960.30.175	960.30.225
.150	174	960.30.225	960.30.275	.110	134	960.30.200	960.30.250
.175	199	960.30.250	960.30.300	.120	144	960.30.200	960.30.250
.200	224	960.30.275	960.30.325				
.225	249	960.30.300	960.30.350				
.250	274	960.30.325	960.30.375				
.275	299	960.30.350	960.30.400				
.300	324	960.30.375	960.30.425				

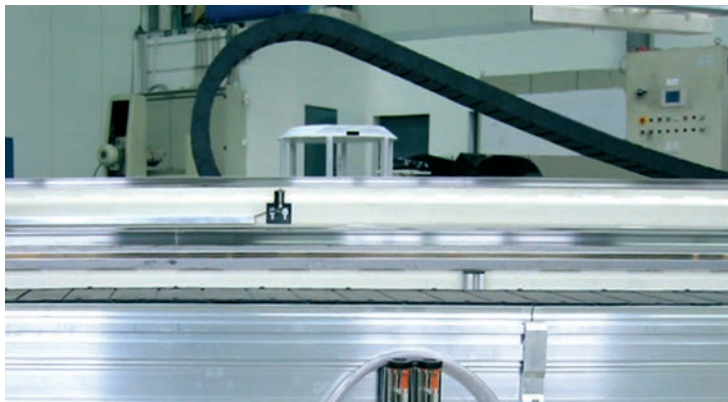

Safely guide the e-chain® across longer travel. Nowadays, users increasingly prefer aluminum (corrosion resistance, weight savings, faster assembly among others)

## Heavy Duty version for high load applications

This Aluminum SuperTrough is also available for plant manufacturing as add-on item with special heavy duty brackets for safe connection: **Installation set Part No. 972.50**. You can configure the heavy duty version at our online-catalog with the respective e-chain® you've chosen. **Further general information about the Aluminum SuperTrough** ► [www.igus.eu/eu/salun](http://www.igus.eu/eu/salun)

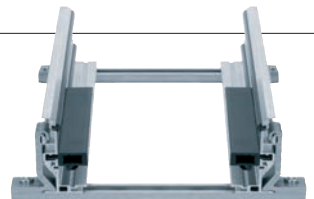





For the following  
igus® Series

## E4.1

● E4.32/H4.32/R4.32

● E4.1 light

● E4.38L

## E6

● E6.40/R6.40

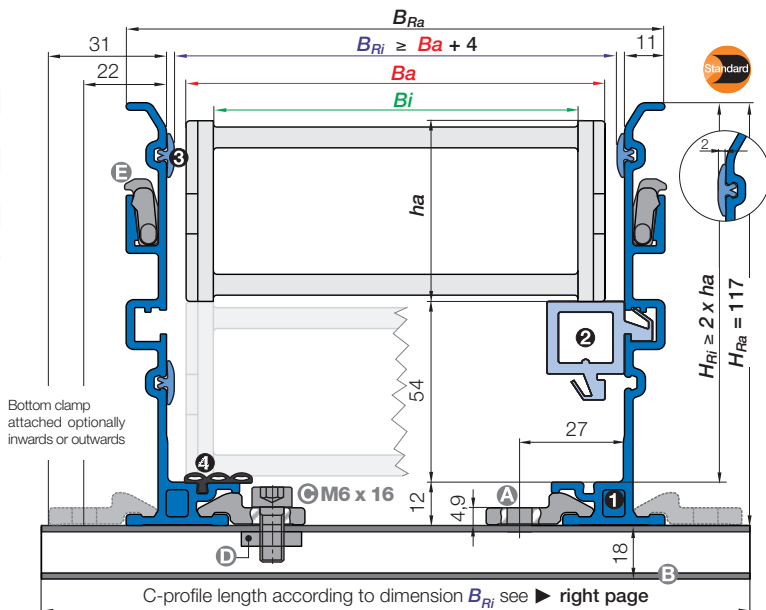

**Note:** The inner width of the guide through and the C-profile length of the assembly kit can differ according to the bracket you choose. Please call us!

## Aluminum SuperTrough | Complete sets

Trough side parts sets - consisting of part 1 / 2 / 3 / 4	Part No.	Weight
Set of 2 trough side parts, incl. glide strips, <b>without</b> glide bars, 2 m section	972.30.SLA**	≈ 6,00 kg
Set of 2 trough side parts, incl. glide strips, <b>with</b> glide bars, 2 m section	972.31.SLA**	≈ 7,40 kg

\*\* For an additional noise dampening with silencer profile, please add index "A" to the Part No. Example: 972.30.SLA

### Installation sets - consisting of part A / B / C / D / E

1 Installation set <b>without</b> C-profile	960.30	≈ 0,06 kg
1 Installation set <b>with</b> C-profile (C-profile length according to dimension $B_{Ri}$ )	960.30.XXX*	upon request

\* Please add the C-profile length as shown on the tables on the right page. Example: 960.30.150

## Aluminum SuperTrough | Components as single parts

Single parts, trough	Part No.	Weight
1 1 Trough side part, individual, 2 m section	72.30	≈ 2,94 kg
2 1 Glide bar, plastic, individual, 2 m section	82.79	≈ 0,60 kg
3 1 Glide strip, plastic, individual, 2 m section	75.01	≈ 0,06 kg
4 1 Silencer profile, rubber, individual, 2 m section (optional for an additional noise dampening)	75.67.H	≈ 0,16 kg
Single parts, installation set		
A 1 Bottom clamp, aluminum individual	75.40	≈ 0,03 kg
B 1 C-profile, individual (C-profile length according to dimension $B_{Ri}$ )	92.52.XXX.E*	≈ 0,90 kg/m
C 1 Screw M6 x 16, individual	MAT 0040209	
D 1 Sliding nut M6, individual	MAT 0040057	
E 1 Interface connector, individual	75.60	

### Additional option for simple fastening of the e-chain® without drilling

1 Set Fixed end module (Detailed information ► page 668)	972.80	
--	--------	--

\* Please add the C-profile length as shown on the tables on the right page. Example: 92.52.125.E

C-profile also available in stainless steel V2A, material 1.4301 (AISI 304). Please add index "E" to the Part No.

# C-profile lengths (according to dim. $B_{Ri}$ ) | Basic Version



972.30.SL  
972.31.SL

Bottom clamp attached optionally inwards or outwards

E4.32/H4.32/R4.32				E4.38L				E6.40/R6.40			
Width index e-chain*	$B_{Ri}$ [mm]	Part No. attached inwards	Part No. attached outwards	Width index e-chain*	$B_{Ri}$ [mm]	Part No. attached inwards	Part No. attached outwards	Width index e-chain*	$B_{Ri}$ [mm]	Part No. attached inwards	Part No. attached outwards
.05	77	960.30.125	960.30.175	050.	70	upon request	960.30.200	.040	64	upon request	960.30.175
.06	95	960.30.150	960.30.200	062.	82	upon request	960.30.200	.050	74	960.30.125	960.30.175
.07	102	960.30.150	960.30.200	075.	95	upon request	960.30.225	.062	86	960.30.150	960.30.200
.087	114	960.30.175	960.30.225	087.	107	upon request	960.30.225	.070	94	960.30.150	960.30.200
.10	127	960.30.175	960.30.225	100.	120	960.30.175	960.30.250	.075	99	960.30.150	960.30.200
.11	135	960.30.200	960.30.250	112.	132	960.30.200	960.30.250	.087	111	960.30.175	960.30.225
.112	140	960.30.200	960.30.250	125.	145	960.30.200	960.30.275	.100	124	960.30.175	960.30.225
.12	152	960.30.200	960.30.250	137.	157	960.30.225	960.30.275	.125	149	960.30.200	960.30.250
.137	165	960.30.225	960.30.275	150.	170	960.30.225	960.30.300	.150	174	960.30.225	960.30.275
.15	177	960.30.225	960.30.275	162.	182	960.30.250	960.30.300	.175	199	960.30.250	960.30.300
.162	190	960.30.250	960.30.300	175.	195	960.30.250	960.30.325	.200	224	960.30.275	960.30.325
.17	195	960.30.250	960.30.300	187.	207	960.30.275	960.30.325	.225	249	960.30.300	960.30.350
.18	202	960.30.250	960.30.300	200.	220	960.30.275	960.30.350	.250	274	960.30.325	960.30.375
.187	215	960.30.275	960.30.325	212.	232	960.30.300	960.30.350	.275	299	960.30.350	960.30.400
.20	227	960.30.275	960.30.325	225.	245	960.30.300	960.30.375	.300	324	960.30.375	960.30.425
.212	240	960.30.300	960.30.350	237.	257	960.30.325	960.30.375				
.23	252	960.30.300	960.30.350	250.	270	960.30.325	960.30.400				
.237	265	960.30.325	960.30.375	262.	282	960.30.350	960.30.400				
.25	277	960.30.325	960.30.375	275.	295	960.30.350	960.30.425				
.262	290	960.30.350	960.30.400	287.	307	960.30.375	960.30.425				
.28	302	960.30.350	960.30.400	300.	320	960.30.375	960.30.450				
.29	315	960.30.375	960.30.425	312.	332	960.30.400	960.30.450				
.30	327	960.30.375	960.30.425	325.	345	960.30.400	960.30.475				
.312	340	960.30.400	960.30.450	337.	357	960.30.425	960.30.475				
.325	352	960.30.400	960.30.450	350.	370	960.30.425	960.30.500				
.337	365	960.30.425	960.30.475	362.	382	960.30.450	960.30.500				
.350	377	960.30.425	960.30.475	375.	395	960.30.450	960.30.525				
.362	390	960.30.450	960.30.500	387.	407	960.30.475	960.30.525				
.375	402	960.30.450	960.30.500	400.	420	960.30.475	960.30.550				
.387	415	960.30.475	960.30.525								
.400	427	960.30.475	960.30.525								

\*Width available upon request,  
please consult igus® for delivery time!

## Heavy Duty version for high load applications

This Aluminum SuperTrough is also available for plant manufacturing as add-on item with special heavy duty brackets for safe connection: **Installation set Part No. 972.50**. You can configure the heavy duty version at our online-catalog with the respective e-chain® you've chosen. **Further general information about the Aluminum SuperTrough** ► [www.igus.eu/eu/salun](http://www.igus.eu/eu/salun)

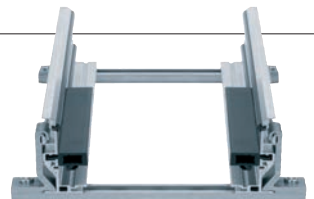

 For the following igus® Series

E2/000

● 2700

E2 e-tubes

● R58

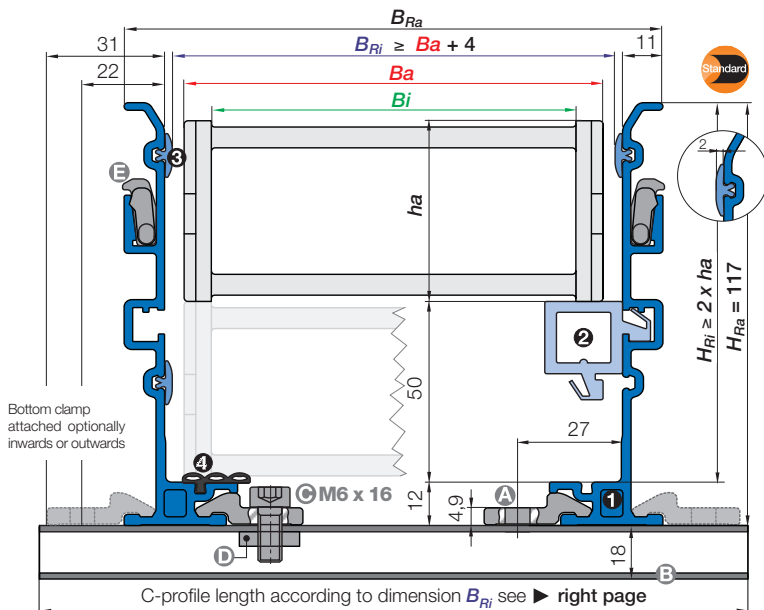

**Note:** The inner width of the guide through and the C-profile length of the assembly kit can differ according to the bracket you choose. Please call us!

## Aluminum SuperTrough | Complete sets

Trough side parts sets - consisting of part ① / ② / ③ / ④	Part No.	Weight
Set of 2 trough side parts, incl. glide strips, <b>without</b> glide bars, 2 m section	972.30.SLA**	≈ 6,00 kg
Set of 2 trough side parts, incl. glide strips, <b>with</b> glide bars, 2 m section	972.32.SLA**	≈ 7,40 kg

\*\* For an additional noise dampening with silencer profile, please add index "A" to the Part No. Example: 972.30.SLA

Installation sets - consisting of part A / B / C / D / E	Part No.	Weight
1 Installation set <b>without</b> C-profile	960.30	≈ 0,06 kg
1 Installation set <b>with</b> C-profile (C-profile length according to dimension $B_{RI}$ )	960.30.XXX*	upon request

\* Please add the C-profile length as shown on the tables on the right page. Example: 960.30.150

## Aluminum SuperTrough | Components as single parts

Single parts, trough	Part No.	Weight
① 1 Trough side part, individual, 2 m section	72.30	≈ 2,94 kg
② 1 Glide bar, plastic, individual, 2 m section	82.79	≈ 0,60 kg
③ 1 Glide strip, plastic, individual, 2 m section	75.01	≈ 0,06 kg
④ 1 Silencer profile, rubber, individual, 2 m section (optional for an additional noise dampening)	75.67.H	≈ 0,16 kg
Single parts, installation set		
A 1 Bottom clamp, aluminum individual	75.40	≈ 0,03 kg
B 1 C-profile, individual (C-profile length according to dimension $B_{RI}$ )	92.52.XXX.E*	≈ 0,90 kg/m
C 1 Screw M6 x 16, individual	MAT 0040209	
D 1 Sliding nut M6, individual	MAT 0040057	
E 1 Interface connector, individual	75.60	

Additional option for simple fastening of the e-chain® without drilling	Part No.
1 Set Fixed end module (Detailed information ► page 668)	972.81

\* Please add the C-profile length as shown on the tables on the right page. Example: 92.52.125.E

C-profile also available in stainless steel V2A, material 1.4301 (AISI 304). Please add index "E" to the Part No.

# C-profile lengths (according to dim. $B_{Ri}$ ) | Basic Version

Bottom clamp attached optionally inwards or outwards



972.30.SL  
972.32.SL

2700				R58			
Width index e-chain* [mm]	$B_{Ri}$	Part No. attached inwards	Part No. attached outwards	Width index e-chain* [mm]	$B_{Ri}$	Part No. attached inwards	Part No. attached outwards
.05	70	upon request	960.30.175	.050	70	upon request	960.30.175
.06	85	960.30.150	960.30.200	.075	95	960.30.150	960.30.200
.07	95	960.30.150	960.30.200	.100	120	960.30.175	960.30.225
.09	110	960.30.175	960.30.225	.125	145	960.30.200	960.30.250
.10	120	960.30.175	960.30.225	.150	170	960.30.225	960.30.275
.12	145	960.30.200	960.30.250	.175	195	960.30.250	960.30.300
.15	170	960.30.225	960.30.275	.200	220	960.30.275	960.30.325
.17	198	960.30.250	960.30.300				



Stable guidance. Crane operating speed 80 m/min.

## Heavy Duty version for high load applications

This Aluminum SuperTrough is also available for plant manufacturing as add-on item with special heavy duty brackets for safe connection: **Installation set Part No. 972.50**. You can configure the heavy duty version at our online-catalog with the respective e-chain\* you've chosen. **Further general information about the Aluminum SuperTrough** ► [www.igus.eu/eu/salun](http://www.igus.eu/eu/salun)



 For the following igus® Series

E2/000

● 3500

E2 e-tubes

● R68

E4.1

● E4.42/H4.42/R4.42

E4.1 light

● E4.48L

E6

● E6.52/R6.52

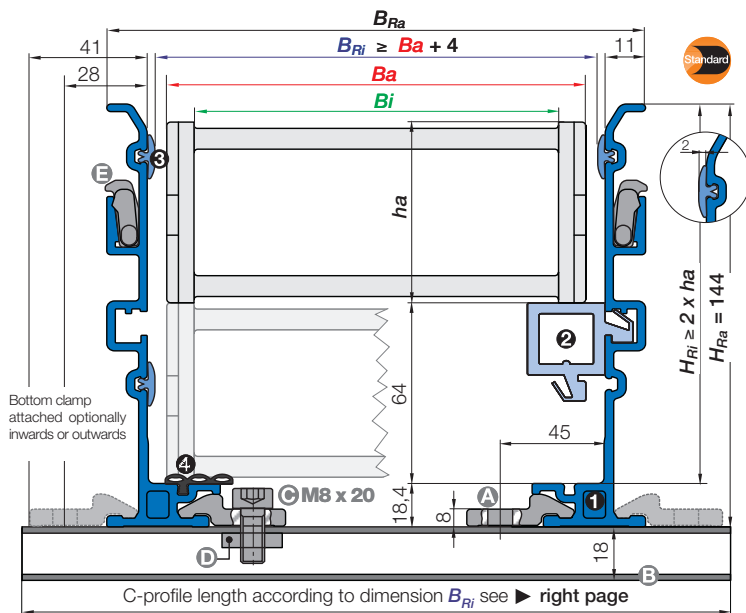

**Note:** The inner width of the guide through and the C-profile length of the assembly kit can differ according to the bracket you choose. Please call us!

## Aluminum SuperTrough | Complete sets

Trough side parts sets - consisting of part ① / ② / ③ / ④	Part No.	Weight
Set of 2 trough side parts, incl. glide strips, <b>without</b> glide bars, 2 m section	973.30.SLA**	≈ 8,00 kg
Set of 2 trough side parts, incl. glide strips, <b>with</b> glide bars, 2 m section	973.31.SLA**	≈ 10,8 kg

\*\* For an additional noise dampening with silencer profile, please add index "A" to the Part No. Example: 973.30.SLA

Installation sets - consisting of part A / B / C / D / E	Part No.	Weight
1 Installation set <b>without</b> C-profile	960.50	≈ 0,08 kg
1 Installation set <b>with</b> C-profile (C-profile length according to dimension $B_{Ri}$ )	960.50.XXX*	upon request

\* Please add the C-profile length as shown on the tables on the right page. Example: 960.50.175

## Aluminum SuperTrough | Components as single parts

Single parts, trough	Part No.	Weight
① 1 Trough side part, individual, 2 m section	73.30	≈ 3,94 kg
② 1 Glide bar, plastic, individual, 2 m section	83.79	≈ 1,30 kg
③ 1 Glide strip, plastic, individual, 2 m section	75.01	≈ 0,06 kg
④ 1 Silencer profile, rubber, individual, 2 m section (optional for an additional noise dampening)	75.68.H	≈ 0,38 kg
Single parts, installation set		
A 1 Bottom clamp, aluminum individual	75.50	≈ 0,04 kg
B 1 C-profile, individual (C-profile length according to dimension $B_{Ri}$ )	92.52.XXX.E*	≈ 0,90 kg/m
C 1 Screw M8 x 20, individual	MAT 0040445	
D 1 Sliding nut M8, individual	MAT 0040413	
E 1 Interface connector, individual	75.60	

### Additional option for simple fastening of the e-chain® without drilling

1 Set Fixed end module (1) Part No. depend on e-chain® Series - Detailed information ► page 668)	973.80 <sup>(1)</sup> / 973.81 <sup>(1)</sup>
--	---

\* Please add the C-profile length as shown on the tables on the right page. Example: 92.52.125.E

C-profile also available in stainless steel V2A, material 1.4301 (AISI 304). Please add index "E" to the Part No.

# C-profile lengths (according to dim. $B_{Ri}$ ) | Basic Version

Bottom clamp attached optionally inwards or outwards



973.30.SL  
973.31.SL

3500				E4.42/H4.42/R4.42				E4.48L				E6.52/R6.52			
Width index e-chain* [mm]	$B_{Ri}$	Part No. attached inwards	Part No. attached outwards	Width index e-chain* [mm]	$B_{Ri}$	Part No. attached inwards	Part No. attached outwards	Width index e-chain* [mm]	$B_{Ri}$	Part No. attached inwards	Part No. attached outwards	Width index e-chain* [mm]	$B_{Ri}$	Part No. attached inwards	Part No. attached outwards
.050	74	upon request	960.50.200	.05	80	upon request	960.50.200	050.	74	upon request	960.40.200	.040	68	upon request	960.50.200
.075	99	upon request	960.50.225	.06	98	upon request	960.50.225	062.*	86	upon request	960.40.200	.050	78	upon request	960.50.200
.100	124	960.50.175	960.50.250	.07	105	upon request	960.50.225	075.	99	upon request	960.40.225	.062	90	upon request	960.50.225
.115	139	960.50.200	960.50.275	.087	118	960.50.175	960.50.250	087.*	111	upon request	960.40.225	.070	98	upon request	960.50.225
.125	149	960.50.200	960.50.275	.10	130	960.50.200	960.50.250	100.	124	960.40.175	960.40.250	.075	103	upon request	960.50.225
.150	174	960.50.225	960.50.300	.11	138	960.50.200	960.50.275	112.*	136	960.40.200	960.40.250	.087	115	upon request	960.50.250
.175	199	960.50.250	960.50.325	.112	143	960.50.200	960.50.275	125.	149	960.40.200	960.40.275	.100	128	960.50.175	960.50.250
.200	224	960.50.275	960.50.350	.12	155	960.50.225	960.50.275	137.*	161	960.40.225	960.40.275	.125	153	960.50.200	960.50.275
.225	249	960.50.300	960.50.375	.137	168	960.50.225	960.50.300	150.	174	960.40.225	960.40.300	.150	178	960.50.225	960.50.300
.250	274	960.50.325	960.50.400	.15	180	960.50.250	960.50.300	162.*	186	960.40.250	960.40.300	.175	203	960.50.250	960.50.325
				.162	193	960.50.250	960.50.325	175.*	199	960.40.250	960.40.325	.200	228	960.50.275	960.50.350
				.17	198	960.50.250	960.50.325	187.*	211	960.40.275	960.40.325	.225	253	960.50.300	960.50.375
				.18	205	960.50.275	960.50.325	200.*	224	960.40.275	960.40.325	.250	278	960.50.325	960.50.400
				.187	218	960.50.275	960.50.350	212.*	236	960.40.300	960.40.350	.275	303	960.50.350	960.50.425
				.20	230	960.50.300	960.50.350	225.*	249	960.40.300	960.40.375	.300	328	960.50.375	960.50.450
				.212	243	960.50.300	960.50.375	237.*	261	960.40.325	960.40.375				
				.23	255	960.50.325	960.50.375	250.*	274	960.40.325	960.40.400				
				.237	268	960.50.325	960.50.400	262.*	286	960.40.350	960.40.400				
				.25	280	960.50.350	960.50.400	275.*	299	960.40.350	960.40.425				
				.262	293	960.50.350	960.50.425	287.*	311	960.40.375	960.40.425				
				.28	305	960.50.375	960.50.425	300.*	324	960.40.375	960.40.450				
				.29	318	960.50.375	960.50.450	312.*	336	960.40.400	960.40.450				
				.30	330	960.50.400	960.50.450	325.*	349	960.40.400	960.40.475				
				.312	343	960.50.400	960.50.475	337.*	361	960.40.425	960.40.475				
				.325	355	960.50.425	960.50.475	350.*	374	960.40.425	960.40.500				
				.337	368	960.50.425	960.50.500	362.*	386	960.40.450	960.40.500				
				.350	380	960.50.450	960.50.500	375.*	399	960.40.450	960.40.525				
				.362	393	960.50.450	960.50.525	387.*	411	960.40.475	960.40.525				
				.375	406	960.50.475	960.50.525	400.*	424	960.40.475	960.40.550				
				.387	418	960.50.475	960.50.550								
				.400	430	960.50.500	960.50.550								

## R68

Width index e-chain* [mm]	$B_{Ri}$	Part No. attached inwards	Part No. attached outwards
.050	72	upon request	960.50.200
.075	97	upon request	960.50.225
.100	122	960.50.175	960.50.250
.115	137	960.50.200	960.50.275
.125	147	960.50.200	960.50.275
.150	172	960.50.225	960.50.300
.175	197	960.50.250	960.50.325
.200	222	960.50.275	960.50.350
.225	247	960.50.300	960.50.375
.250	272	960.50.325	960.50.400

\*Width available upon request,  
please consult igus® for delivery time!

## Heavy Duty version for high load applications

This Aluminum SuperTrough is also available for plant manufacturing as add-on item with special heavy duty brackets for safe connection: **Installation set Part No. 973.50**. You can configure the heavy duty version at our online-catalog with the respective e-chain® you've chosen. **Further general information about the Aluminum SuperTrough** ► [www.igus.eu/eu/salun](http://www.igus.eu/eu/salun)

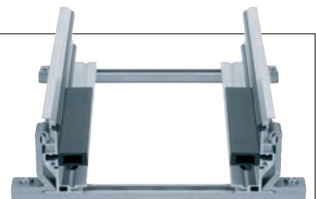

 For the following igus® Series

### E4.1

● E4.56/H4.56/R4.56

### E4/light

● 14040/14140/R18840

● 14240/14340

### E6

● E6.62

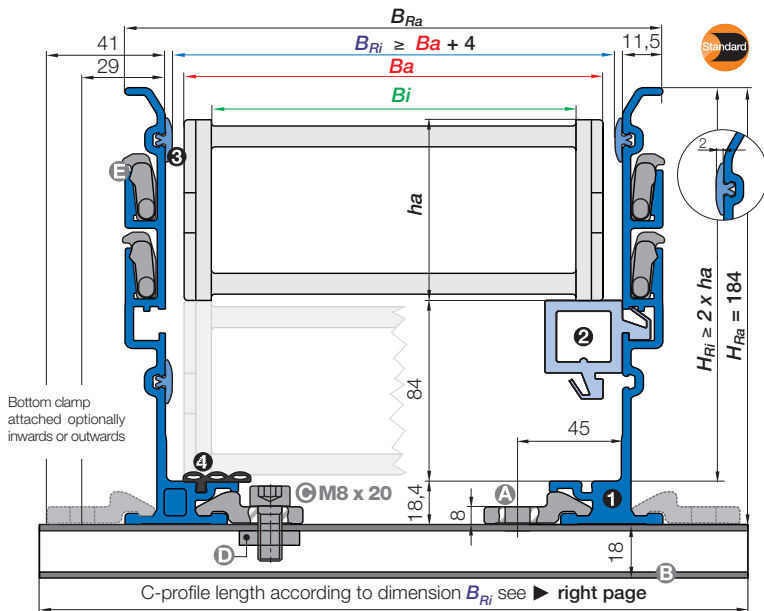

**Note:** The inner width of the guide through and the C-profile length of the assembly kit can differ according to the bracket you choose. Please call us!

## Aluminum SuperTrough | Complete sets

Trough side parts sets - consisting of part 1 / 2 / 3 / 4	Part No.	Weight
Set of 2 trough side parts, incl. glide strips, <b>without</b> glide bars, 2 m section	974.30.SLA**	≈ 10,0 kg
Set of 2 trough side parts, incl. glide strips, <b>with</b> glide bars, 2 m section	974.31.SLA**	≈ 12,8 kg

\*\* For an additional noise dampening with silencer profile, please add index "A" to the Part No. Example: 974.30.SLA

Installation sets - consisting of part A / B / C / D / E	Part No.	Weight
1 Installation set <b>without</b> C-profile	960.50	≈ 0,08 kg
1 Installation set <b>with</b> C-profile (C-profile length according to dimension $B_{Rl}$ )	960.50.XXX*	upon request

\* Please add the C-profile length as shown on the tables on the right page. Example: 960.50.200

## Aluminum SuperTrough | Components as single parts

Single parts, trough	Part No.	Weight
1 1 Trough side part, individual, 2 m section	74.30*	≈ 4,94 kg
2 1 Glide bar, plastic, individual, 2 m section	83.79	≈ 1,30 kg
3 1 Glide strip, plastic, individual, 2 m section	75.01	≈ 0,06 kg
4 1 Silencer profile, rubber, individual, 2 m section (optional for an additional noise dampening)	75.68.H	≈ 0,38 kg
Single parts, installation set		
A 1 Bottom clamp, aluminum individual	75.50	≈ 0,04 kg
B 1 C-profile, individual (C-profile length according to dimension $B_{Rl}$ )	92.52.XXX.E*	≈ 0,90 kg/m
C 1 Screw M8 x 20, individual	MAT 0040445	
D 1 Sliding nut M8, individual	MAT 0040413	
E 1 Interface connector, individual	75.60	

### Additional option for simple fastening of the e-chain® without drilling

1 Set Fixed end module (1) Part No. depend on e-chain® Series - Detailed information ► page 668)	974.80 <sup>1)</sup> / 974.81 <sup>1)</sup>
--	---

\* Please add the C-profile length as shown on the tables on the right page. Example: 92.52.125.E

C-profile also available in stainless steel V2A, material 1.4301 (AISI 304). Please add index "E" to the Part No.



974.30.SL  
974.31.SL

# C-profile lengths (according to dim. $B_{Ri}$ ) | Basic Version

Bottom clamp attached optionally inwards or outwards

E4.56/H4.56/R4.56				14040/14140/R18840				14240/14340				E6.62			
Width index e-chain <sup>®</sup> [mm]	$B_{Ri}$	Part No. attached inwards	Part No. attached outwards	Width index e-chain <sup>®</sup> [mm]	$B_{Ri}$	Part No. attached inwards	Part No. attached outwards	Width index e-chain <sup>®</sup> [mm]	$B_{Ri}$	Part No. attached inwards	Part No. attached outwards	Width index e-chain <sup>®</sup> [mm]	$B_{Ri}$	Part No. attached inwards	Part No. attached outwards
.05	88	upon request	960.50.225	.05	80	upon request	960.50.200	.05	80	upon request	960.50.200	.05	90	upon request	960.50.225
.06	103	upon request	960.50.225	.06	95	upon request	960.50.225	.06	98	upon request	960.50.225	.06	108	upon request	960.50.225
.07	113	upon request	960.50.250	.07	105	upon request	960.50.225	.07	105	upon request	960.50.225	.07	115	upon request	960.50.250
.08	125	960.50.175	960.50.250	.08	117	960.50.175	960.50.225	.087	118	960.50.175	960.50.250	.087	127	960.50.175	960.50.250
.10	138	960.50.200	960.50.275	.10	130	960.50.200	960.50.250	.10	130	960.50.200	960.50.250	.10	140	960.50.200	960.50.275
.11	151	960.50.200	960.50.275	.11	143	960.50.200	960.50.275	.11	138	960.50.200	960.50.275	.11	148	960.50.200	960.50.275
.12	163	960.50.225	960.50.300	.12	155	960.50.225	960.50.275	.112	143	960.50.200	960.50.275	.112	152	960.50.200	960.50.275
.13	176	960.50.225	960.50.300	.13	168	960.50.225	960.50.300	.12	155	960.50.225	960.50.275	.12	165	960.50.225	960.50.300
.15	188	960.50.250	960.50.325	.15	180	960.50.250	960.50.300	.137	168	960.50.225	960.50.300	.137	177	960.50.225	960.50.300
.16	201	960.50.250	960.50.325	.16	193	960.50.250	960.50.325	.15	180	960.50.250	960.50.300	.15	190	960.50.250	960.50.325
.17	213	960.50.275	960.50.350	.17	205	960.50.275	960.50.325	.162	193	960.50.250	960.50.325	.162	202	960.50.250	960.50.325
.18	226	960.50.275	960.50.350	.18	218	960.50.275	960.50.350	.17	198	960.50.250	960.50.325	.17	208	960.50.275	960.50.325
.20	238	960.50.300	960.50.375	.20	230	960.50.300	960.50.350	.18	205	960.50.275	960.50.325	.18	215	960.50.275	960.50.350
.21	251	960.50.300	960.50.375	.21	243	960.50.300	960.50.375	.187	218	960.50.275	960.50.350	.187	227	960.50.275	960.50.350
.22	263	960.50.325	960.50.400	.22	255	960.50.325	960.50.375	.20	230	960.50.300	960.50.350	.20	240	960.50.300	960.50.375
.23	276	960.50.325	960.50.400	.23	268	960.50.325	960.50.400	.212	243	960.50.300	960.50.375	.212	252	960.50.300	960.50.375
.25	288	960.50.350	960.50.425	.25	280	960.50.350	960.50.400	.23	255	960.50.325	960.50.375	.23	265	960.50.325	960.50.400
.26	301	960.50.350	960.50.425	.26	293	960.50.350	960.50.425	.237	268	960.50.325	960.50.400	.237	277	960.50.325	960.50.400
.27	313	960.50.375	960.50.450	.27	305	960.50.375	960.50.425	.25	280	960.50.350	960.50.400	.25	290	960.50.350	960.50.425
.28	326	960.50.375	960.50.450	.28	318	960.50.375	960.50.450	.262	293	960.50.350	960.50.425	.262	302	960.50.350	960.50.425
.30	338	960.50.400	960.50.475	.30	330	960.50.400	960.50.450	.28	305	960.50.375	960.50.425	.28	315	960.50.375	960.50.450
.31	351	960.50.400	960.50.475	.31	343	960.50.400	960.50.475	.29	318	960.50.375	960.50.450	.29	327	960.50.375	960.50.450
.32	363	960.50.425	960.50.500	.32	355	960.50.425	960.50.475	.30	330	960.50.400	960.50.450	.30	340	960.50.400	960.50.475
.33	376	960.50.425	960.50.500	.33	368	960.50.425	960.50.500	.312	343	960.50.400	960.50.475	.312	352	960.50.400	960.50.475
.35	388	960.50.450	960.50.525	.35	380	960.50.450	960.50.500	.325	355	960.50.425	960.50.475	.325	365	960.50.425	960.50.500
.36	401	960.50.450	960.50.525	.36	393	960.50.450	960.50.525	.337	368	960.50.425	960.50.500	.337	377	960.50.425	960.50.500
.37	413	960.50.475	960.50.550	.37	405	960.50.475	960.50.525	.350	380	960.50.450	960.50.500	.350	390	960.50.450	960.50.525
.38	426	960.50.475	960.50.550	.38	418	960.50.475	960.50.550	.362	393	960.50.450	960.50.525	.362	402	960.50.450	960.50.525
.40	438	960.50.500	960.50.575	.40	430	960.50.500	960.50.550	.375	405	960.50.475	960.50.525	.375	415	960.50.475	960.50.550
.41	451	960.50.500	960.50.575	.41	443	960.50.500	960.50.575	.387	418	960.50.475	960.50.550	.387	427	960.50.475	960.50.550
.42	463	960.50.525	960.50.600	.42	455	960.50.525	960.50.575	.400	430	960.50.500	960.50.550	.400	440	960.50.500	960.50.575
.43	476	960.50.525	960.50.600	.43	468	960.50.525	960.50.600								
.45	488	960.50.550	960.50.625	.45	480	960.50.550	960.50.600								
.46	501	960.50.550	960.50.625	.46	493	960.50.550	960.50.625								
.47	513	960.50.575	960.50.650	.47	505	960.50.575	960.50.625								
.48	526	960.50.575	960.50.650	.48	518	960.50.575	960.50.650								
.50	538	960.50.600	960.50.675	.50	530	960.50.600	960.50.650								
.51	551	960.50.600	960.50.675	.51	543	960.50.600	960.50.675								
.52	563	960.50.625	960.50.700	.52	555	960.50.625	960.50.675								
.53	576	960.50.625	960.50.700	.53	568	960.50.625	960.50.700								
.55	588	960.50.650	960.50.725	.55	580	960.50.650	960.50.700								
.60	638	960.50.700	960.50.775	.60	630	960.50.700	960.50.750								

## Heavy Duty version for high load applications

This Aluminum SuperTrough is also available for plant manufacturing as add-on item with special heavy duty brackets for safe connection: **Installation set Part No. 974.50.** You can configure the heavy duty version at our online-catalog with the respective e-chain<sup>®</sup> you've chosen. **Further general information about the Aluminum SuperTrough** ► [www.igus.eu/eu/salun](http://www.igus.eu/eu/salun)

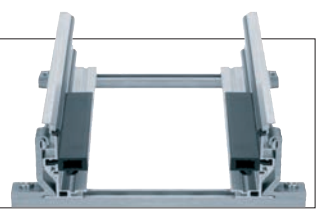





# C-profile lengths (according to dim. $B_{Ri}$ ) | Basic Version



975.30.SL  
975.31.SL

Bottom clamp attached optionally inwards or outwards

E4.80/H4.80/R4.80				15050/15150/R19850				15250/15350				E6.80			
Width index e-chain <sup>a</sup> [mm]	$B_{Ri}$	Part No. attached inwards	Part No. attached outwards	Width index e-chain <sup>a</sup> [mm]	$B_{Ri}$	Part No. attached inwards	Part No. attached outwards	Width index e-chain <sup>a</sup> [mm]	$B_{Ri}$	Part No. attached inwards	Part No. attached outwards	Width index e-chain <sup>a</sup> [mm]	$B_{Ri}$	Part No. attached inwards	Part No. attached outwards
.05	104	upon request	960.50.225	.05	84	upon request	960.50.200	.05	84	upon request	960.50.200	.05	104	upon request	960.50.225
.06	119	upon request	960.50.250	.06	99	upon request	960.50.225	.06	102	upon request	960.50.225	.06	119	upon request	960.50.250
.07	129	upon request	960.50.250	.07	109	upon request	960.50.225	.07	109	upon request	960.50.225	.07	129	upon request	960.50.250
.08	141	960.50.200	960.50.275	.08	121	upon request	960.50.250	.087	121	upon request	960.50.250	.08	141	960.50.200	960.50.275
.10	154	960.50.225	960.50.275	.10	134	upon request	960.50.250	.09	131	upon request	960.50.250	.10	154	960.50.225	960.50.275
.11	167	960.50.225	960.50.300	.11	146	960.50.200	960.50.275	.10	134	upon request	960.50.250	.11	167	960.50.225	960.50.300
.12	179	960.50.250	960.50.300	.12	159	960.50.225	960.50.275	.11	142	960.50.200	960.50.250	.12	179	960.50.250	960.50.300
.13	192	960.50.250	960.50.325	.13	171	960.50.225	960.50.300	.112	147	960.50.200	960.50.275	.13	192	960.50.250	960.50.325
.15	204	960.50.275	960.50.325	.15	184	960.50.250	960.50.300	.12	159	960.50.225	960.50.275	.15	204	960.50.275	960.50.325
.16	217	960.50.275	960.50.350	.16	196	960.50.250	960.50.325	.137	171	960.50.225	960.50.300	.16	217	960.50.275	960.50.350
.17	229	960.50.300	960.50.350	.17	209	960.50.275	960.50.325	.15	184	960.50.250	960.50.300	.17	229	960.50.300	960.50.350
.18	242	960.50.300	960.50.375	.18	221	960.50.275	960.50.350	.162	197	960.50.250	960.50.325	.18	242	960.50.300	960.50.375
.20	254	960.50.325	960.50.375	.20	234	960.50.300	960.50.350	.17	202	960.50.250	960.50.325	.20	254	960.50.325	960.50.375
.21	267	960.50.325	960.50.400	.21	246	960.50.300	960.50.375	.18	209	960.50.275	960.50.325	.21	267	960.50.325	960.50.400
.22	279	960.50.350	960.50.400	.22	259	960.50.325	960.50.375	.187	222	960.50.275	960.50.350	.22	279	960.50.350	960.50.400
.23	292	960.50.350	960.50.425	.23	271	960.50.325	960.50.400	.20	234	960.50.300	960.50.350	.23	292	960.50.350	960.50.425
.25	304	960.50.375	960.50.425	.25	284	960.50.350	960.50.400	.212	247	960.50.300	960.50.375	.25	304	960.50.375	960.50.425
.26	317	960.50.375	960.50.450	.26	296	960.50.350	960.50.425	.23	259	960.50.325	960.50.375	.26	317	960.50.375	960.50.450
.27	329	960.50.400	960.50.450	.27	309	960.50.375	960.50.425	.237	272	960.50.325	960.50.400	.27	329	960.50.400	960.50.450
.28	342	960.50.400	960.50.475	.28	321	960.50.375	960.50.450	.25	284	960.50.350	960.50.400	.28	342	960.50.400	960.50.475
.30	354	960.50.425	960.50.475	.30	334	960.50.400	960.50.450	.262	297	960.50.350	960.50.425	.30	354	960.50.425	960.50.475
.31	367	960.50.425	960.50.500	.31	346	960.50.400	960.50.475	.28	309	960.50.375	960.50.425	.31	367	960.50.425	960.50.500
.32	379	960.50.450	960.50.500	.32	359	960.50.425	960.50.475	.29	322	960.50.375	960.50.450	.32	379	960.50.450	960.50.500
.33	392	960.50.450	960.50.525	.33	371	960.50.425	960.50.500	.30	334	960.50.400	960.50.450	.33	392	960.50.450	960.50.525
.35	404	960.50.475	960.50.525	.35	384	960.50.450	960.50.500	.312	347	960.50.400	960.50.475	.35	404	960.50.475	960.50.525
.36	417	960.50.475	960.50.550	.36	396	960.50.450	960.50.525	.325	359	960.50.425	960.50.475	.36	417	960.50.475	960.50.550
.37	429	960.50.500	960.50.550	.37	409	960.50.475	960.50.525	.337	372	960.50.425	960.50.500	.37	429	960.50.500	960.50.550
.38	442	960.50.500	960.50.575	.38	421	960.50.475	960.50.550	.350	384	960.50.450	960.50.500	.38	442	960.50.500	960.50.575
.40	454	960.50.525	960.50.575	.40	434	960.50.500	960.50.550	.362	397	960.50.450	960.50.525	.40	454	960.50.525	960.50.575
.41	467	960.50.525	960.50.600	.41	446	960.50.500	960.50.575	.375	409	960.50.475	960.50.525	.41	467	960.50.525	960.50.600
.42	479	960.50.550	960.50.600	.42	459	960.50.525	960.50.575	.387	422	960.50.475	960.50.550	.42	479	960.50.550	960.50.600
.43	492	960.50.550	960.50.625	.43	471	960.50.525	960.50.600	.400	434	960.50.500	960.50.550	.43	492	960.50.550	960.50.625
.45	504	960.50.575	960.50.625	.45	484	960.50.550	960.50.600					.45	504	960.50.575	960.50.625
.46	517	960.50.575	960.50.650	.46	496	960.50.550	960.50.625					.46	517	960.50.575	960.50.650
.47	529	960.50.600	960.50.650	.47	509	960.50.575	960.50.625					.47	529	960.50.600	960.50.650
.48	542	960.50.600	960.50.675	.48	521	960.50.575	960.50.650					.48	542	960.50.600	960.50.675
.50	554	960.50.625	960.50.675	.50	534	960.50.600	960.50.650					.50	554	960.50.625	960.50.675
.51	567	960.50.625	960.50.700	.51	546	960.50.600	960.50.675					.51	567	960.50.625	960.50.700
.52	579	960.50.650	960.50.700	.52	559	960.50.625	960.50.675					.52	579	960.50.650	960.50.700
.53	592	960.50.650	960.50.725	.53	571	960.50.625	960.50.700					.53	592	960.50.650	960.50.725
.55	604	960.50.675	960.50.725	.55	584	960.50.650	960.50.700					.55	604	960.50.675	960.50.725
.60	654	960.50.725	960.50.775	.60	634	960.50.700	960.50.750					.60	654	960.50.725	960.50.775

## Heavy Duty version for high load applications

This Aluminum SuperTrough is also available for plant manufacturing as add-on item with special heavy duty brackets for safe connection: **Installation set Part No. 975.50**. You can configure the heavy duty version at our online-catalog with the respective e-chain<sup>a</sup> you've chosen. **Further general information about the Aluminum SuperTrough** ► [www.igus.eu/eu/salun](http://www.igus.eu/eu/salun)

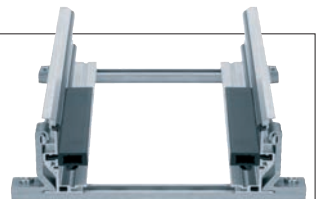

# Steel Guide Trough | Introduction | Advantages

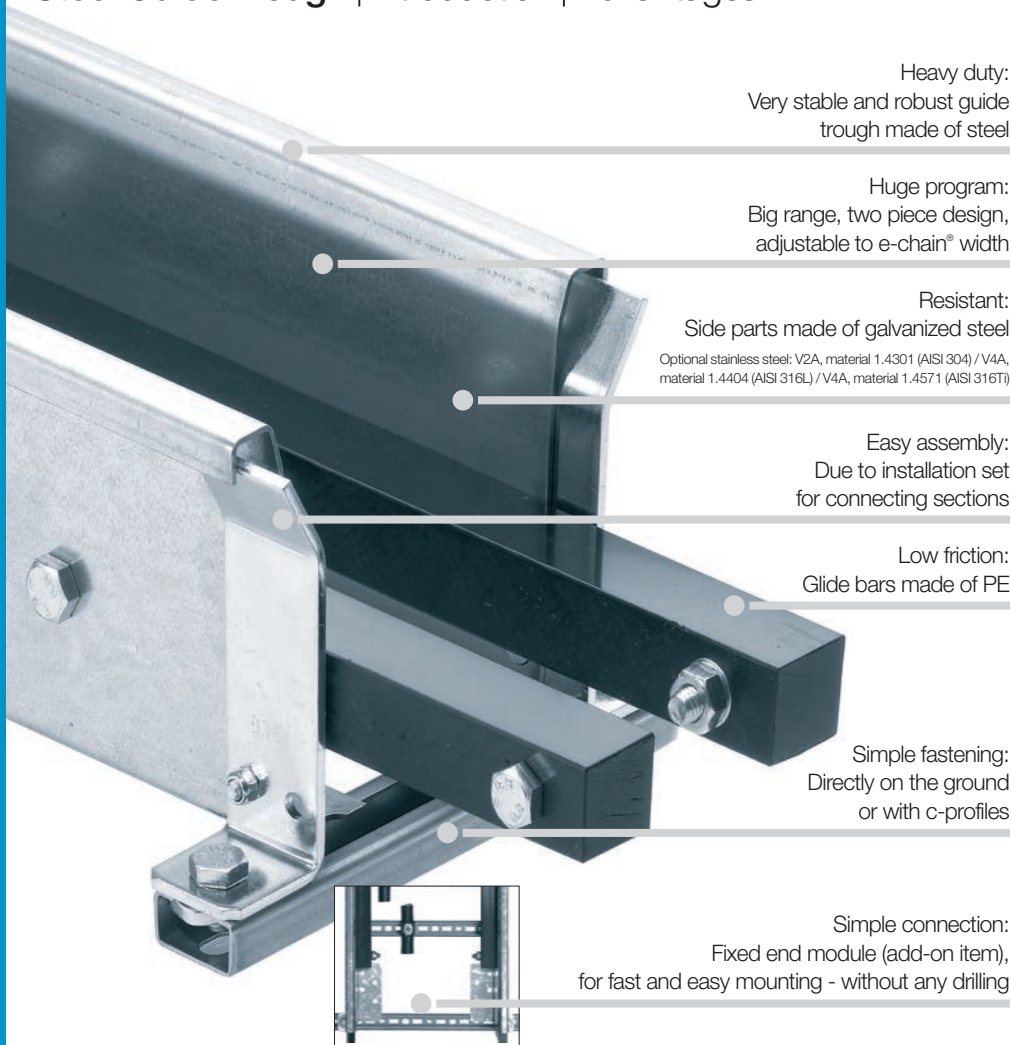

Heavy duty:  
Very stable and robust guide  
trough made of steel

Huge program:  
Big range, two piece design,  
adjustable to e-chain® width

Resistant:  
Side parts made of galvanized steel  
Optional stainless steel: V2A, material 1.4301 (AISI 304) / V4A,  
material 1.4404 (AISI 316L) / V4A, material 1.4571 (AISI 316Ti)

Easy assembly:  
Due to installation set  
for connecting sections

Low friction:  
Glide bars made of PE

Simple fastening:  
Directly on the ground  
or with c-profiles

Simple connection:  
Fixed end module (add-on item),  
for fast and easy mounting - without any drilling

## Steel guide trough | Very stable and rugged for heavy duty applications

If the igus® installation sets are used, the guide troughs are particularly easy to assemble. All steel guide troughs are constructed according to the same basic principle. On the following pages, you will find information about dimensions, weights and accessories according to the trough size. All sizes use a common C-profile on which the guide parts are assembled. The assembly brackets used vary in height only.

Installation Guide-PDF with detailed assembly information ► [www.igus.eu/eu/installation-guide-pdf](http://www.igus.eu/eu/installation-guide-pdf)



# Steel Guide Trough | Selection Table



Series Part No.	Outer trough height $H_{Ra}$ [mm]	Installation set* Part No.	Side part material	Page	
<b>92.30   92.31</b>	70	<b>92.50</b>	Galvanized steel <sup>1)</sup>	<b>694</b>	
<b>95.30   95.31</b>	100	<b>95.50</b>	Galvanized steel <sup>1)</sup>	<b>696</b>	
<b>99.30   99.31</b>	100	<b>95.50</b>	Galvanized steel <sup>1)</sup>	<b>698</b>	
<b>97.30   97.31</b>	130	<b>93.50</b>	Galvanized steel <sup>1)</sup>	<b>700</b>	
<b>93.30   93.31</b>	130	<b>93.50</b>	Galvanized steel <sup>1)</sup>	<b>702</b>	
<b>94.30   94.31</b>	170	<b>94.50</b>	Galvanized steel <sup>1)</sup>	<b>704</b>	
<b>94.14550.30   94.14550.31</b> <b>New</b> *	170	<b>94.50</b>	Galvanized steel <sup>1)</sup>	<b>706</b>	
<b>96.30   96.31</b>	220	<b>96.50</b>	Galvanized steel <sup>1)</sup>	<b>708</b>	
<b>98.30   98.31</b>	300	<b>98.50</b>	Galvanized steel <sup>1)</sup>	<b>710</b>	
<b>90.30   90.31</b>	480	<b>90.50</b>	Galvanized steel <sup>1)</sup>	<b>712</b>	
<b>91.10 - 91.71</b> <sup>2)</sup>	48	–	Galvanized steel	<b>692</b>	

**Steel guide troughs**  
 very stable and rugged for  
 Heavy-Duty applications

\* in this catalog

<sup>1)</sup> Optional in stainless steel: V2A, material 1.4301 (AISI 304) / V4A, material 1.4404 (AISI 316L) / V4A, material 1.4571 (AISI 316Ti)

<sup>2)</sup> Steel guide troughs, one-piece. Only for Series 10, 15 and B15

## Steel guide trough | Sizes Overview

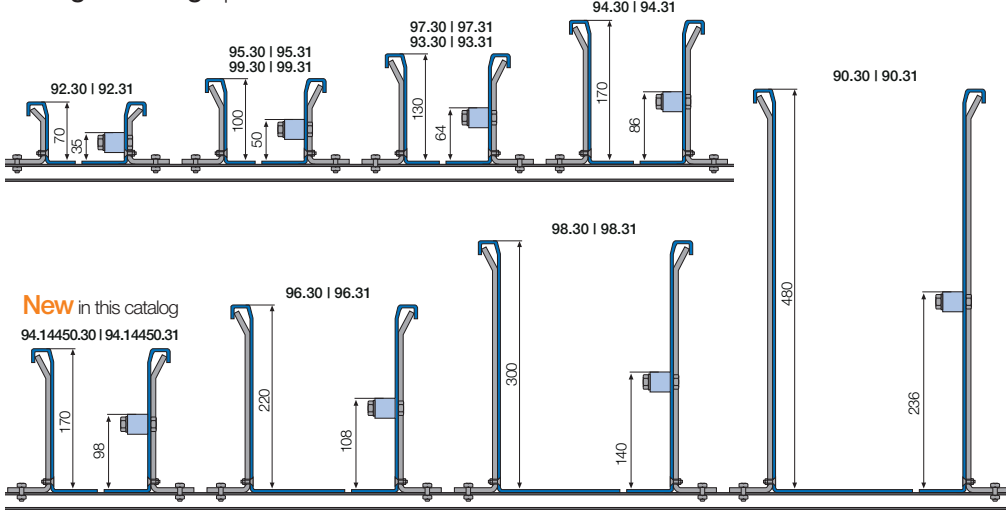

# Steel Guide Trough | Parts

## Components

- = Guide trough <sup>1)</sup>
- = Glide bar
- = Installation set
- = C-profile <sup>2)</sup>

- Ba** = Outer e-chain® width
- Bi** = Inner e-chain® width
- ha** = e-chain® outer height
- H<sub>Ri</sub>** = Inner trough height
- H<sub>Ra</sub>** = Outer trough height
- B<sub>Ri</sub>** = Inner trough width
- B<sub>Ra</sub>** = Outer trough width
- n<sub>Mon</sub>** = Number of installation sets (left/right)
- n<sub>Ri</sub>** = Number of trough sets (left/right)

**H<sub>Ri</sub> ≥ 2 x ha**

**B<sub>Ri</sub> ≥ Ba + 5**

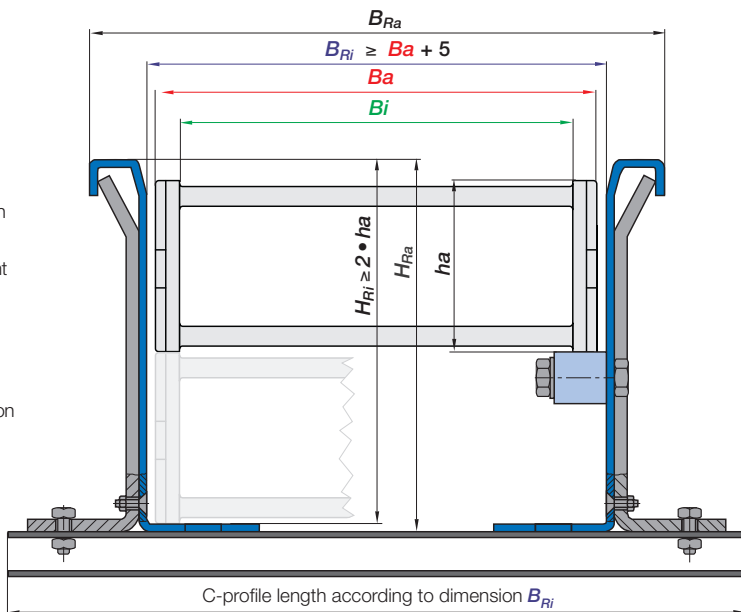

1) Guide trough side parts, galvanized steel. Optional stainless steel: V2A, material 1.4301 (AISI 304) / V4A, material 1.4404 (AISI 316L) / V4A, material 1.4571 (AISI 316Ti)  
 2) C-profile also available in stainless steel V2A, material 1.4301 (AISI 304)

## Steel Guide Trough | Features



Steel Guide Trough without and with glide bars available

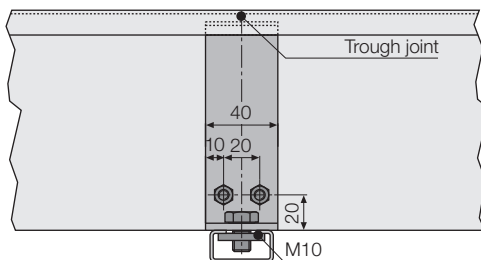

Side view of trough joint. All dimensions, apart from the height, apply to all sizes

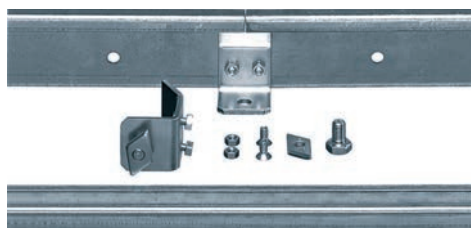

Installation set for joint and attachment surface connections secure connection without misalignment and without welding



## Steel Guide Trough | Configuration according to your requirements

Quick and easy assemble the right trough for your application

- Selection of the suitable guide trough according to the e-chain® Series and e-chain® width  $B_i$
- Determine the feeding point of the cables
- Determine travel distance and thus the length of the required guide trough and the number of trough pieces. (Standard length of a trough side plate: 2000 mm). The length of the guide trough - for axial feeding - is calculated from half the travel length with and half the travel length without the glide bar
- Number and selection of the assembly kit

The quantity of the assembly kit is calculated from the number of the trough pieces + 1 kit:

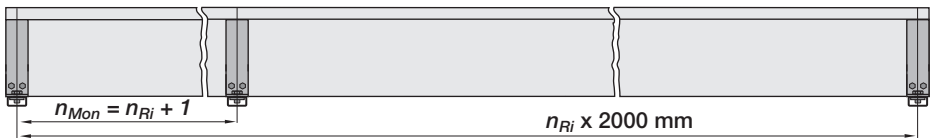

- The assembly kit matches the igus c-profile option
- If you have opted for an e-chain® with KMA mounting brackets, we offer you a fixed-end module for the quick and simple fastening of the e-chain® in the trough without holes

Installation Guide-PDF with detailed assembly information

► [www.igus.eu/eu/installation-guide-pdf](http://www.igus.eu/eu/installation-guide-pdf)

## Order example | Based on Part No. 94.30 | 94.31



Order example: Length of travel 30 m -

Center mounted for Series E4.56.20.300.0 with  $B_{Ri} = 239$

Guide trough set (set of 2 trough side parts, incl. glide strips) **without** glide bar

Order text: 16 m guide trough without glide bar (8 x 2 m sections) Part No. 94.30

Guide trough set (set of 2 trough side parts, incl. glide strips) **with** glide bar

Order text: 16 m guide trough with glide bar (8 x 2 m sections) Part No. 94.31

Installation set complete (guide trough-sets + 1)

Order text: 17 installation sets Part No. 94.50.350

Module for the fixed end

Order text: 1 set Part No. 94.80.01



Calculation - travel center mounted: Half travel length, rounded down to full 2 m sections = X m guide trough length without glide bars + X m guide trough length with glide bars + installation sets (number of trough pieces + 1)

# Steel Guide Trough | Fixed end module

## Fixed end module | Quick and simple fastening onto the Steel Guide Trough

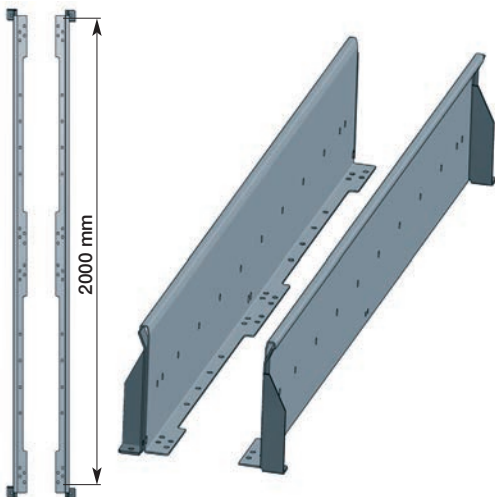

Until now, the steel trough had to be modified on site to fit the mounting brackets at the stationary end of the e-chain\*. That is now history. With its prefabricated boreholes, the 2.000 mm long kit can be used for middle-feed, end-feed and opposed installation.

- ❶ Fast fixation of mounting brackets thanks to prefabricated boreholes
- ❷ Fast installation of C-profile for strain relief
- ❸ Fast bolting of glide bars

**Industries:** Power plants, coal conveyors, mining, composting plants, raw material storage, gipsumplants, etc.

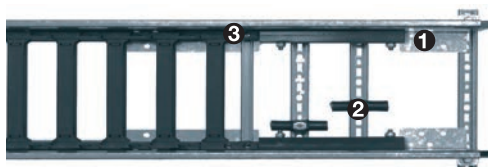

Part No.	For Steel Guide Trough		For e-chain* Series
90.80.01*	90.30	90.31	800, 840
92.80.01*	92.30	92.31	2500, 255, E6.29/R6.29
93.80.01	93.30	93.31	3500, R68, E4.42/H4.42/R4.42, E4.48L, E6.52/R6.52
94.80.01	94.30	94.31	E4.56/H4.56/R4.56, 14040/14140 /R18840, 14240/14340, E6.62
95.80.01*	95.30	95.31	2700
96.80.01	96.30	96.31	E4.80/H4.80/R4.80, 15050/5150/R19850, E6.80
97.80.01	97.30	97.31	E4.32/H4.32/R4.32, E4.38L, E6.40/R6.40
98.80.01	98.30	98.31	E4.112/H4.112/R4.112, 1640/R1608
99.80.01	99.30	99.31	E4.28/R4.28, 220/R760, E6.35
94.14550.80.01*	94.14550.30	94.14550.31	14550/14650/R19050

\*Available upon request, please consult igus\* for delivery time!



The 2000 mm long fixed end module



# Steel Guide Trough | One-piece, U-shaped

## Special solution for Series 10, B15 and 15

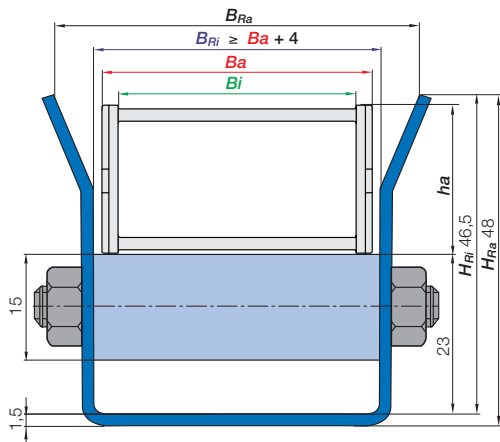

### Components

- = Guide trough
- = Glide bar
- = Installation set

- Ba** = Outer e-chain® width
- Bi** = Inner e-chain® width
- ha** = e-chain® outer height
- H<sub>Ri</sub>** = Inner trough height
- H<sub>Ra</sub>** = Outer trough height
- B<sub>Ri</sub>** = Inner trough width
- B<sub>Ra</sub>** = Outer trough width



For the following igus® Series

### E2 mini

- 10
- B15
- zipper
- 15

For Series 10, 15 and B15 are one-piece, U-shaped steel guide troughs available. They have got a continuous glide bar for the transition from area with the glide bars to the area without glide bars. Available from stock are the guide troughs for the e-chains® with an outer width up to 60 mm. For the e-chains® with a width of more than 60 mm special solutions are possible. For this trough sizes are no installation sets necessary as the guide troughs are made of a single U-profile. The solution for the trough joint is specific for every application.



	Part No.	Dim. $B_{Ra}$ [mm]	Dim. $B_{Ri}$ [mm]	Weight
<b>For Series 10.015/15.015/B15.015</b>				
Trough <b>without</b> glide bar, 2-m section	91.10	40,5	30	1,50 kg/m
Trough <b>with</b> glide bar, 2-m section	91.11	40,5	30	2,10 kg/m
<b>For Series 10.025/15.025/B15.025</b>				
Trough <b>without</b> glide bar, 2-m section	91.20	50,5	40	1,65 kg/m
Trough <b>with</b> glide bar, 2-m section	91.21	50,5	40	2,35 kg/m
<b>For Series 10.038/15.038/B15.038</b>				
Trough <b>without</b> glide bar, 2-m section	91.30	62,5	52	1,80 kg/m
Trough <b>with</b> glide bar, 2-m section	91.31	62,5	52	2,70 kg/m
<b>For Series 10.050/15.050/B15.050</b>				
Trough <b>without</b> glide bar, 2-m section	91.40	72,5	62	1,90 kg/m
Trough <b>with</b> glide bar, 2-m section	91.41	72,5	62	3,15 kg/m
<b>For Series 10.5/15.5/B15.5</b>				
Trough <b>without</b> glide bar, 2-m section	91.50	89,5	79	2,15 kg/m
Trough <b>with</b> glide bar, 2-m section	91.51	89,5	79	4,30 kg/m
<b>For Series 10.6/15.6/B15.6</b>				
Trough <b>without</b> glide bar, 2-m section	91.60	106,5	96	≈ 2,40 kg/m
Trough <b>with</b> glide bar, 2-m section	91.61	106,5	96	≈ 4,60 kg/m
<b>For Series 10.7/15.7/B15.7</b>				
Trough <b>without</b> glide bar, 2-m section	91.70	126,5	116	≈ 2,80 kg/m
Trough <b>with</b> glide bar, 2-m section	91.71	126,5	116	≈ 5,20 kg/m

Material galvanized steel.





For the following  
igus® Series

E2/000 (E2 medium)

● 2500

● 255

E6

● E6.29/R6.29

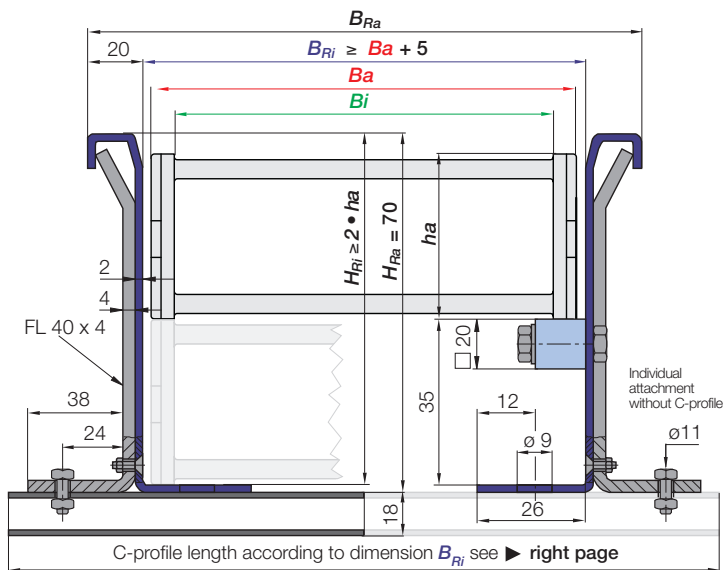

**Note:** The inner width of the guide trough and the C-profile length of the assembly kit can differ according to the bracket you choose. Please call us!

## Steel Guide Trough | Complete sets

Trough side parts sets	Part No.	Weight
Set of 2 trough side parts, <b>without</b> glide bars, 2 m section	92.30.E <sup>1)</sup> / E44 <sup>2)</sup> / E45 <sup>3)</sup>	≈ 7,60 kg
Set of 2 trough side parts, <b>with</b> glide bars, 2 m section	92.31.E <sup>1)</sup> / E44 <sup>2)</sup> / E45 <sup>3)</sup>	≈ 9,60 kg
Installation sets - consisting of part		
1 Installation set <b>without</b> C-profile	92.50	≈ 0,34 kg
1 Installation set <b>with</b> C-profile (C-profile length according to dimension $B_{Ri}$ )	92.50.XXX*	upon request

\* Please add the C-profile length as shown on the tables on the right page. Example: 92.50.200

## Steel Guide Trough | Components as single parts

Single parts, trough	Part No.	Weight
1 Trough side part, individual, 2 m section	92.11.E <sup>1)</sup> / E44 <sup>2)</sup> / E45 <sup>3)</sup>	≈ 3,80 kg
1 Glide bar, individual, each 2 m	92.01	≈ 0,75 kg
1 Glide bar, individual, each 2 m + 11 screw sets	92.20	≈ 0,98 kg
Single parts, installation set		
11 Screw sets for 2 m sections	92.21	≈ 0,23 kg
1 Clamping bracket, individual	92.51	≈ 0,12 kg
1 Countersunk-head screw M6 x 14, individual	92.53	
1 Hexagon nut M6, individual	92.54	
1 Hexagon-head screw M10 x 16, individual	92.55	
1 Glide nut M10, individual	92.56	
1 C-profile, individual (C-profile length according to dimension $B_{Ri}$ )	92.52.XXX*.E <sup>1)</sup>	≈ 0,90 kg/m
Additional option for simple fastening of the e-chain® without drilling		
1 Set Fixed end module (Detailed information ► page 692)	90.80.01	≈ 7,60 kg

\* Please add the C-profile length as shown on the tables on the right page. Example: 92.52.200.E

1) Trough side parts + C-profile - Also available in stainless steel V2A, material 1.4301 (AISI 304). Please add index "E" to the Part No.

2) Trough side parts - Also available in stainless steel V4A, material 1.4404 (AISI 316L). Please add index ".E44" to the Part No.

3) Trough side parts - Also available in stainless steel V4A, material 1.4571 (AISI 316Ti). Please add index ".E45" to the Part No.

# Steel Guide Trough | C-profile lengths

C-profile length according to dim.  $B_{Ri}$



92.30  
92.31

2500		
Width index e-chain*	$B_{Ri}$ [mm]	Part No. Installation set
.02	46	upon request
.03	59	92.50.175
.05	78	92.50.200
.07	98	92.50.225
.09	110	92.50.225
.10	124	92.50.250
.12	146	92.50.275

255		
Width index e-chain*	$B_{Ri}$ [mm]	Part No. Installation set
.03	59	92.50.175
.05	78	92.50.200
.07	98	92.50.225
.10	124	92.50.250

E6.29/R6.29		
Width index e-chain*	$B_{Ri}$ [mm]	Part No. Installation set
.030	51	upon request
.040	61	92.50.175
.050	71	92.50.200
.060	81	92.50.200
.070	91	92.50.200
.080	101	92.50.225
.090	111	92.50.225
.100	121	92.50.250
.110	131	92.50.250
.120	141	92.50.250



igus® steel guide trough used in a robotics application

 For the following igus® Series

E2/000

● 2700

E2

● R58

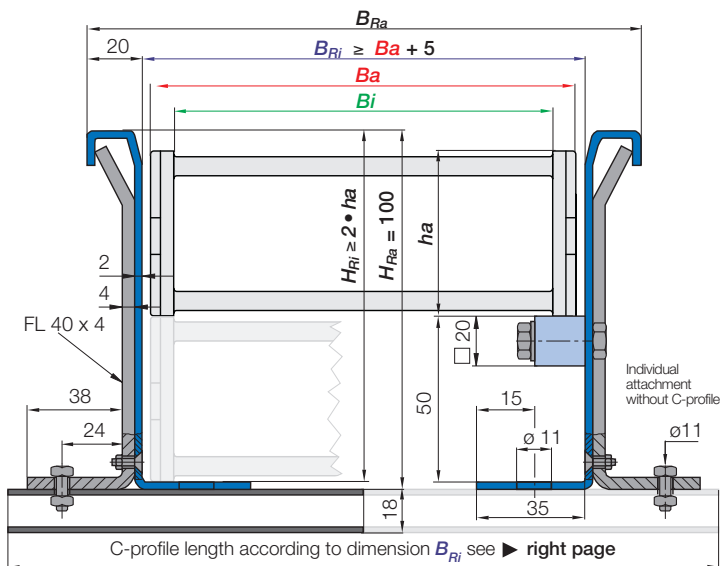

**Note:** The inner width of the guide trough and the C-profile length of the assembly kit can differ according to the bracket you choose. Please call us!

## Steel Guide Trough | Complete sets

Trough side parts sets	Part No.	Weight
Set of 2 trough side parts, <b>without</b> glide bars, 2 m section	95.30.E <sup>1)</sup> / E44 <sup>2)</sup> / E45 <sup>3)</sup>	≈ 10,00 kg
Set of 2 trough side parts, <b>with</b> glide bars, 2 m section	95.31.E <sup>1)</sup> / E44 <sup>2)</sup> / E45 <sup>3)</sup>	≈ 12,00 kg
Installation sets - consisting of part		
1 Installation set <b>without</b> C-profile	95.50	≈ 0,41 kg
1 Installation set <b>with</b> C-profile (C-profile length according to dimension $B_{Ri}$ )	95.50.XXX*	upon request

\* Please add the C-profile length as shown on the tables on the right page. Example: 95.50.200

## Steel Guide Trough | Components as single parts

Single parts, trough	Part No.	Weight
1 Trough side part, individual, 2 m section	95.11.E <sup>1)</sup> / E44 <sup>2)</sup> / E45 <sup>3)</sup>	≈ 5,00 kg
1 Glide bar, individual, each 2 m	92.01	≈ 0,75 kg
1 Glide bar, individual, each 2 m + 11 screw sets	92.20	≈ 0,98 kg
Single parts, installation set		
11 Screw sets for 2 m sections	92.21	≈ 0,23 kg
1 Clamping bracket, individual	95.51	≈ 0,16 kg
1 Countersunk-head screw M6 x 14, individual	92.53	
1 Hexagon nut M6, individual	92.54	
1 Hexagon-head screw M10 x 16, individual	92.55	
1 Glide nut M10, individual	92.56	
1 C-profile, individual (C-profile length according to dimension $B_{Ri}$ )	92.52.XXX*.E <sup>1)</sup>	≈ 0,90 kg/m
Additional option for simple fastening of the e-chain® without drilling		
1 Set Fixed end module (For Series R58, upon request. Detailed information ► page 692)	95.80.01	≈ 10,00 kg

\* Please add the C-profile length as shown on the tables on the right page. Example: 92.52.200.E

1) Trough side parts + C-profile - Also available in stainless steel V2A, material 1.4301 (AISI 304). Please add index ".E" to the Part No.

2) Trough side parts - Also available in stainless steel V4A, material 1.4404 (AISI 316L). Please add index ".E44" to the Part No.

3) Trough side parts - Also available in stainless steel V4A, material 1.4571 (AISI 316Ti). Please add index ".E45" to the Part No.

# Steel Guide Trough | C-profile lengths

C-profile length according to dim.  $B_{Ri}$



95.30  
95.31

2700		
Width index e-chain*	$B_{Ri}$ [mm]	Part No. Installation set
.05	71	95.50.200
.06	86	95.50.200
.07	96	95.50.225
.09	111	95.50.225
.10	121	95.50.250
.12	146	95.50.275
.15	171	95.50.300
.17	199	95.50.325

R58		
Width index e-chain*	$B_{Ri}$ [mm]	Part No. Installation set
.050	71	95.50.200
.075	96	95.50.225
.100	121	95.50.250
.125	146	95.50.275
.150	171	95.50.300
.175	196	95.50.325
.200	221	95.50.350



igus® steel guide trough used in a shelf conveyor application, Series E2/000 and chainflex® cables



For the following  
igus® Series

E4.1

● E4.28/R4.28

E6

● E6.35

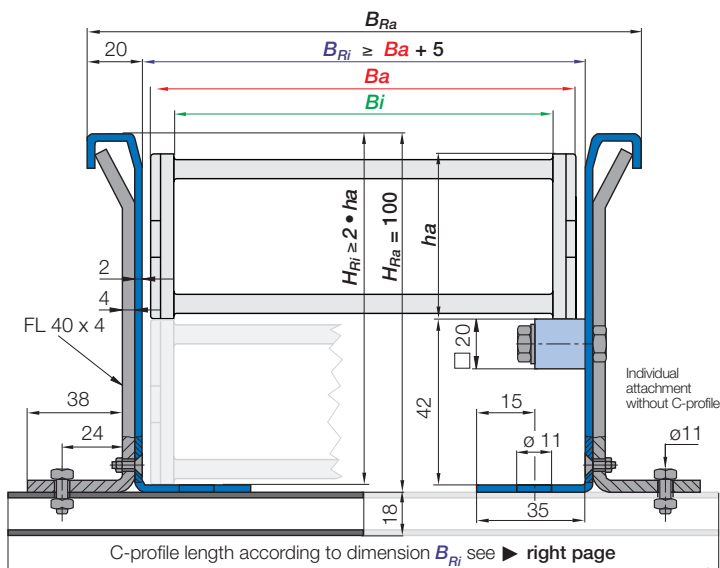

**Note:** The inner width of the guide trough and the C-profile length of the assembly kit can differ according to the bracket you choose. Please call us!

## Steel Guide Trough | Complete sets

Trough side parts sets	Part No.	Weight
Set of 2 trough side parts, <b>without</b> glide bars, 2 m section	99.30.E <sup>1)</sup> / E44 <sup>2)</sup> / E45 <sup>3)</sup>	≈ 10,00 kg
Set of 2 trough side parts, <b>with</b> glide bars, 2 m section	99.31.E <sup>1)</sup> / E44 <sup>2)</sup> / E45 <sup>3)</sup>	≈ 12,00 kg
Installation sets - consisting of part		
1 Installation set <b>without</b> C-profile	95.50	≈ 0,41kg
1 Installation set <b>with</b> C-profile (C-profile length according to dimension $B_{Ri}$ )	95.50.XXX*	upon request

\* Please add the C-profile length as shown on the tables on the right page. Example: 92.50.200

## Steel Guide Trough | Components as single parts

Single parts, trough	Part No.	Weight
1 Trough side part, individual, 2 m section	99.11.E <sup>1)</sup> / E44 <sup>2)</sup> / E45 <sup>3)</sup>	≈ 5,00 kg
1 Glide bar, individual, each 2 m	92.01	≈ 0,75 kg
1 Glide bar, individual, each 2 m + 11 screw sets	92.20	≈ 0,98 kg
Single parts, installation set		
11 Screw sets for 2 m sections	92.21	≈ 0,23 kg
1 Clamping bracket, individual	95.51	≈ 0,16 kg
1 Countersunk-head screw M6 x 14, individual	92.53	
1 Hexagon nut M6, individual	92.54	
1 Hexagon-head screw M10 x 16, individual	92.55	
1 Glide nut M10, individual	92.56	
1 C-profile, individual (C-profile length according to dimension $B_{Ri}$ )	92.52.XXX*.E <sup>1)</sup>	≈ 0,90 kg/m
Additional option for simple fastening of the e-chain® without drilling		
1 Set Fixed end module (Detailed information ► page 692)	99.80.01	≈ 10,00 kg

\* Please add the C-profile length as shown on the tables on the right page. Example: 92.50.200

- 1) Trough side parts + C-profile - Also available in stainless steel V2A, material 1.4301 (AISI 304). Please add index ".E" to the Part No.
- 2) Trough side parts - Also available in stainless steel V4A, material 1.4404 (AISI 316L). Please add index ".E44" to the Part No.
- 3) Trough side parts - Also available in stainless steel V4A, material 1.4571 (AISI 316Ti). Please add index ".E45" to the Part No.

# Steel Guide Trough | C-profile lengths

C-profile length according to dim.  $B_{Ri}$



99.30  
99.31

## E4.28/R4.28

Width index e-chain®	$B_{Ri}$ [mm]	Part No. Installation set
.040	65	upon request
.050	75	95.50.200
.062	87	95.50.200
.070	95	95.50.200
.075	100	95.50.225
.087	112	95.50.225
.100	125	95.50.250
.125	150	95.50.275
.150	175	95.50.300
.175	200	95.50.325
.200	225	95.50.350
.225	250	95.50.375
.250	275	95.50.400
.275	300	95.50.425
.300	325	95.50.450

## E6.35

Width index e-chain®	$B_{Ri}$ [mm]	Part No. Installation set
.030	55	upon request
.040	65	upon request
.050	75	95.50.200
.060	85	95.50.200
.070	95	95.50.200
.080	105	95.50.225
.090	115	95.50.225
.100	125	95.50.250
.110	135	95.50.250
.120	145	95.50.250



Light weight and high stability: Polymer e-chain® tames stiff hydraulic hoses

# Steel Guide Trough | 97.30 | 97.31 | Heavy-Duty

Trough height: 130 mm | Delivery program

 For the following igus® Series

E4.1

● E4.32/H4.32/R4.32

E4.1 light

● E4.38L

E6

● E6.40/R6.40

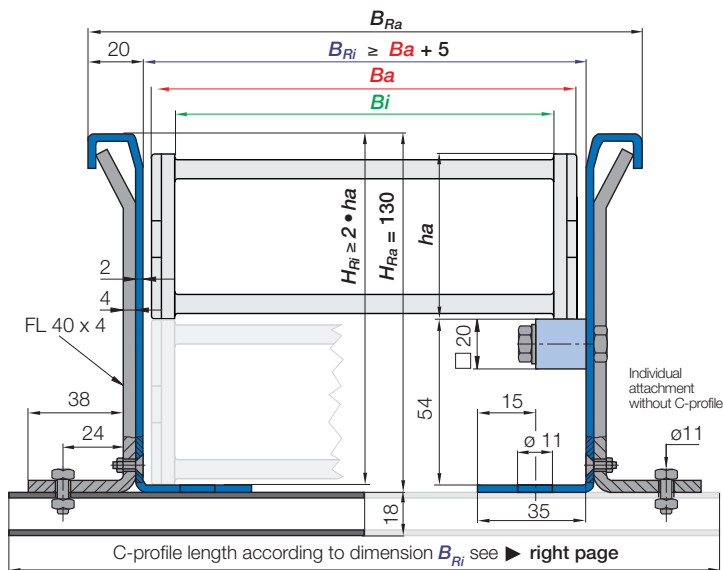

**Note:** The inner width of the guide trough and the C-profile length of the assembly kit can differ according to the bracket you choose. Please call us!

## Steel Guide Trough | Complete sets

Trough side parts sets	Part No.	Weight
Set of 2 trough side parts, <b>without</b> glide bars, 2 m section	97.30.E <sup>1)</sup> / E44 <sup>2)</sup> / E45 <sup>3)</sup>	≈ 11,80 kg
Set of 2 trough side parts, <b>with</b> glide bars, 2 m section	97.31.E <sup>1)</sup> / E44 <sup>2)</sup> / E45 <sup>3)</sup>	≈ 13,60 kg
Installation sets - consisting of part		
1 Installation set <b>without</b> C-profile	93.50	≈ 0,49 kg
1 Installation set <b>with</b> C-profile (C-profile length according to dimension $B_{Ri}$ )	93.50.XXX*	upon request

\* Please add the C-profile length as shown on the tables on the right page. Example: 93.50.350

## Steel Guide Trough | Components as single parts

Single parts, trough	Part No.	Weight
1 Trough side part, individual, 2 m section	97.11.E <sup>1)</sup> / E44 <sup>2)</sup> / E45 <sup>3)</sup>	≈ 5,90 kg
1 Glide bar, individual, each 2 m	92.01	≈ 0,75 kg
1 Glide bar, individual, each 2 m + 11 screw sets	92.20	≈ 0,98 kg
Single parts, installation set		
11 Screw sets for 2 m sections	92.21	≈ 0,23 kg
1 Clamping bracket, individual	93.51	≈ 0,20 kg
1 Countersunk-head screw M6 x 14, individual	92.53	
1 Hexagon nut M6, individual	92.54	
1 Hexagon-head screw M10 x 16, individual	92.55	
1 Glide nut M10, individual	92.56	
1 C-profile, individual (C-profile length according to dimension $B_{Ri}$ )	92.52.XXX*.E <sup>1)</sup>	≈ 0,90 kg/m
Additional option for simple fastening of the e-chain® without drilling		
1 Set Fixed end module (Detailed information ► page 692)	97.80.01	≈ 11,80 kg

\* Please add the C-profile length as shown on the tables on the right page. Example: 92.52.350

1) Trough side parts + C-profile - Also available in stainless steel V2A, material 1.4301 (AISI 304). Please add index ".E" to the Part No.

2) Trough side parts - Also available in stainless steel V4A, material 1.4404 (AISI 316L). Please add index ".E44" to the Part No.

3) Trough side parts - Also available in stainless steel V4A, material 1.4571 (AISI 316Ti). Please add index ".E45" to the Part No.

# Steel Guide Trough | C-profile lengths

C-profile length according to dim.  $B_{Ri}$



97.30  
97.31

E4.32/H4.32/R4.32			E4.38L			E6.40/R6.40		
Width index e-chain*	$B_{Ri}$ [mm]	Part No. Installation set	Width index e-chain*	$B_{Ri}$ [mm]	Part No. Installation set	Width index e-chain*	$B_{Ri}$ [mm]	Part No. Installation set
.05	78	93.50. 200	.050.	71	93.50 200	.040	65	upon request
.06	96	93.50. 225	.062.*	83	93.50 200	.050	75	93.50. 200
.07	103	93.50. 225	.075.	96	93.50 225	.062	87	93.50. 200
.087	115	93.50. 225	.087.*	108	93.50 225	.070	95	93.50. 225
.10	128	93.50. 250	.100.	121	93.50 250	.075	100	93.50. 225
.11	136	93.50. 250	.112.*	133	93.50 250	.087	112	93.50. 225
.112	141	93.50. 250	.125.	146	93.50 275	.100	125	93.50. 250
.12	153	93.50. 275	.137.*	158	93.50 275	.125	150	93.50. 275
.137	166	93.50. 275	.150.	171	93.50 300	.150	175	93.50. 300
.15	178	93.50. 300	.162.*	183	93.50 300	.175	200	93.50. 325
.162	191	93.50. 300	.175.*	196	93.50 325	.200	225	93.50. 350
.17	196	93.50. 325	.187.*	208	93.50 325	.225	250	93.50. 375
.18	203	93.50. 325	.200.*	221	93.50 350	.250	275	93.50. 400
.187	216	93.50. 325	.212.*	233	93.50 350	.275	300	93.50. 425
.20	228	93.50. 350	.225.*	246	93.50 375	.300	325	93.50. 450
.212	241	93.50. 350	.237.*	258	93.50 375			
.23	253	93.50. 375	.250.*	271	93.50 400			
.237	266	93.50. 375	.262.*	283	93.50 400			
.25	278	93.50. 400	.275.*	296	93.50 425			
.262	291	93.50. 400	.287.*	308	93.50 425			
.28	303	93.50. 425	.300.*	321	93.50 450			
.29	316	93.50. 425	.312.*	333	93.50 450			
.30	328	93.50. 450	.325.*	346	93.50 475			
.312	341	93.50. 450	.337.*	358	93.50 475			
.325	353	93.50. 475	.350.*	371	93.50 500			
.337	366	93.50. 475	.362.*	383	93.50 500			
.350	378	93.50. 500	.375.*	396	93.50 525			
.362	391	93.50. 500	.387.*	408	93.50 525			
.375	403	93.50. 525	.400.*	421	93.50 550			
.387	416	93.50. 525						
.400	428	93.50. 550						

\*Width available upon request, please consult igus\* for delivery time!



igus® System E4 with extension link at a ship loader for the coal unloading. Travel 105 m, speed 240 m/min, load 53 kg/m



# Steel Guide Trough | 93.30 | 93.31 | Heavy-Duty

Trough height: 130 mm | Delivery program

 For the following igus® Series

E2/000

● 3500

E2

● R68

E4.1

● E4.42/H4.42/R4.42

E4.1 light

● E4.48L

E6

● E6.52/R6.52

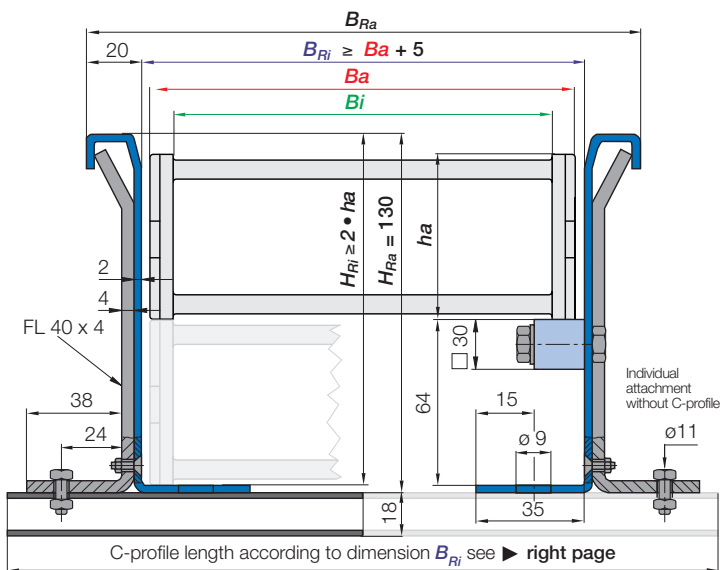

**Note:** The inner width of the guide trough and the C-profile length of the assembly kit can differ according to the bracket you choose. Please call us!

C-profile length according to dimension  $B_{Ri}$  see ► right page

## Steel Guide Trough | Complete sets

Trough side parts sets	Part No.	Weight
Set of 2 trough side parts, <b>without</b> glide bars, 2 m section	93.30.E <sup>1)</sup> / E44 <sup>2)</sup> / E45 <sup>3)</sup>	= 11,80 kg
Set of 2 trough side parts, <b>with</b> glide bars, 2 m section	93.31.E <sup>1)</sup> / E44 <sup>2)</sup> / E45 <sup>3)</sup>	= 16,20 kg
Installation sets - consisting of part		
1 Installation set <b>without</b> C-profile	93.50	= 0,49 kg
1 Installation set <b>with</b> C-profile (C-profile length according to dimension $B_{Ri}$ )	93.50.XXX*	upon request

\* Please add the C-profile length as shown on the tables on the right page. Example: 93.50.350

## Steel Guide Trough | Components as single parts

Single parts, trough	Part No.	Weight
1 Trough side part, individual, 2 m section	93.11.E <sup>1)</sup> / E44 <sup>2)</sup> / E45 <sup>3)</sup>	= 5,90 kg
1 Glide bar, individual, each 2 m	93.01	= 1,68 kg
1 Glide bar, individual, each 2 m + 11 screw sets	93.20	= 2,22 kg
Single parts, installation set		
11 Screw sets for 2 m sections	93.21	= 0,54 kg
1 Clamping bracket, individual	93.51	= 0,20 kg
1 Countersunk-head screw M6 x 14, individual	92.53	
1 Hexagon nut M6, individual	92.54	
1 Hexagon-head screw M10 x 16, individual	92.55	
1 Glide nut M10, individual	92.56	
1 C-profile, individual (C-profile length according to dimension $B_{Ri}$ )	92.52.XXX*.E <sup>1)</sup>	= 0,90 kg/m
Additional option for simple fastening of the e-chain® without drilling		
1 Set Fixed end module (Detailed information ► page 692)	93.80.01	= 11,80 kg

\* Please add the C-profile length as shown on the tables on the right page. Example: 92.52.350

1) Trough side parts + C-profile - Also available in stainless steel V2A, material 1.4301 (AISI 304). Please add index ".E" to the Part No.

2) Trough side parts - Also available in stainless steel V4A, material 1.4404 (AISI 316L). Please add index ".E44" to the Part No.

3) Trough side parts - Also available in stainless steel V4A, material 1.4571 (AISI 316Ti). Please add index ".E45" to the Part No.

# Steel Guide Trough | C-profile lengths

C-profile length according to dim.  $B_{Ri}$



93.30  
93.31

3500		
Width index e-chain*	$B_{Ri}$ [mm]	Part No. Installation set
.050	75	93.50. 200
.075	100	93.50. 225
.100	125	93.50. 250
.115	140	93.50. 250
.125	150	93.50. 275
.150	175	93.50. 300
.175	200	93.50. 325
.200	225	93.50. 350
.225	250	93.50. 375
.250	275	93.50. 400

E4.42/H4.42/R4.42		
Width index e-chain*	$B_{Ri}$ [mm]	Part No. Installation set
.05	81	93.50. 200
.06	99	93.50. 225
.07	106	93.50. 225
.087	119	93.50. 250
.10	131	93.50. 250
.11	139	93.50. 250
.112	144	93.50. 275
.12	156	93.50. 275
.137	169	93.50. 300
.15	181	93.50. 300
.162	194	93.50. 325
.17	199	93.50. 325
.18	206	93.50. 325
.187	219	93.50. 350
.20	231	93.50. 350
.212	244	93.50. 375
.23	256	93.50. 375
.237	269	93.50. 400
.25	281	93.50. 400
.262	294	93.50. 425
.28	306	93.50. 425
.29	319	93.50. 450
.30	331	93.50. 450
.312	344	93.50. 475
.325	356	93.50. 475
.337	369	93.50. 500
.350	381	93.50. 500
.362	394	93.50. 525
.375	407	93.50. 525
.387	419	93.50. 550
.400	431	93.50. 550

E4.48L		
Width index e-chain*	$B_{Ri}$ [mm]	Part No. Installation set
050.	75	93.50 200
062.*	87	93.50 200
075.	100	93.50 225
087.*	112	93.50 225
100.	125	93.50 250
112.*	137	93.50 250
125.	150	93.50 275
137.*	162	93.50 275
150.	175	93.50 300
162.*	187	93.50 300
175.*	200	93.50 325
187.*	212	93.50 325
200.*	225	93.50 350
212.*	237	93.50 350
225.*	250	93.50 375
237.*	262	93.50 375
250.*	275	93.50 400
262.*	287	93.50 400
275.*	300	93.50 425
287.*	312	93.50 425
300.*	325	93.50 450
312.*	337	93.50 450
325.*	350	93.50 475
337.*	362	93.50 475
350.*	375	93.50 500
362.*	387	93.50 500
375.*	400	93.50 525
387.*	412	93.50 525
400.*	425	93.50 550

E6.52/R6.52		
Width index e-chain*	$B_{Ri}$ [mm]	Part No. Installation set
.040	69	upon request
.050	79	93.50. 200
.062	91	93.50. 200
.070	99	93.50. 225
.075	104	93.50. 225
.087	116	93.50. 225
.100	129	93.50. 250
.125	154	93.50. 275
.150	179	93.50. 300
.175	204	93.50. 325
.200	229	93.50. 350
.225	254	93.50. 375
.250	279	93.50. 400
.275	304	93.50. 425
.300	329	93.50. 450

R68		
Width index e-chain*	$B_{Ri}$ [mm]	Part No. Installation set
.050	73	93.50. 200
.075	98	93.50. 225
.100	123	93.50. 250
.115	138	93.50. 250
.125	148	93.50. 275
.150	173	93.50. 300
.175	198	93.50. 325
.200	223	93.50. 350
.225	248	93.50. 375
.250	273	93.50. 400

E4.48L		
Width index e-chain*	$B_{Ri}$ [mm]	Part No. Installation set
.05	81	93.50. 200
.06	99	93.50. 225
.07	106	93.50. 225
.087	119	93.50. 250
.10	131	93.50. 250
.11	139	93.50. 250
.112	144	93.50. 275
.12	156	93.50. 275
.137	169	93.50. 300
.15	181	93.50. 300
.162	194	93.50. 325
.17	199	93.50. 325
.18	206	93.50. 325
.187	219	93.50. 350
.20	231	93.50. 350
.212	244	93.50. 375
.23	256	93.50. 375
.237	269	93.50. 400
.25	281	93.50. 400
.262	294	93.50. 425
.28	306	93.50. 425
.29	319	93.50. 450
.30	331	93.50. 450
.312	344	93.50. 475
.325	356	93.50. 475
.337	369	93.50. 500
.350	381	93.50. 500
.362	394	93.50. 525
.375	407	93.50. 525
.387	419	93.50. 550
.400	431	93.50. 550

E4.48L		
Width index e-chain*	$B_{Ri}$ [mm]	Part No. Installation set
050.	75	93.50 200
062.*	87	93.50 200
075.	100	93.50 225
087.*	112	93.50 225
100.	125	93.50 250
112.*	137	93.50 250
125.	150	93.50 275
137.*	162	93.50 275
150.	175	93.50 300
162.*	187	93.50 300
175.*	200	93.50 325
187.*	212	93.50 325
200.*	225	93.50 350
212.*	237	93.50 350
225.*	250	93.50 375
237.*	262	93.50 375
250.*	275	93.50 400
262.*	287	93.50 400
275.*	300	93.50 425
287.*	312	93.50 425
300.*	325	93.50 450
312.*	337	93.50 450
325.*	350	93.50 475
337.*	362	93.50 475
350.*	375	93.50 500
362.*	387	93.50 500
375.*	400	93.50 525
387.*	412	93.50 525
400.*	425	93.50 550

E6.52/R6.52		
Width index e-chain*	$B_{Ri}$ [mm]	Part No. Installation set
.040	69	upon request
.050	79	93.50. 200
.062	91	93.50. 200
.070	99	93.50. 225
.075	104	93.50. 225
.087	116	93.50. 225
.100	129	93.50. 250
.125	154	93.50. 275
.150	179	93.50. 300
.175	204	93.50. 325
.200	229	93.50. 350
.225	254	93.50. 375
.250	279	93.50. 400
.275	304	93.50. 425
.300	329	93.50. 450

\*Width available upon request, please consult igus® for delivery time!

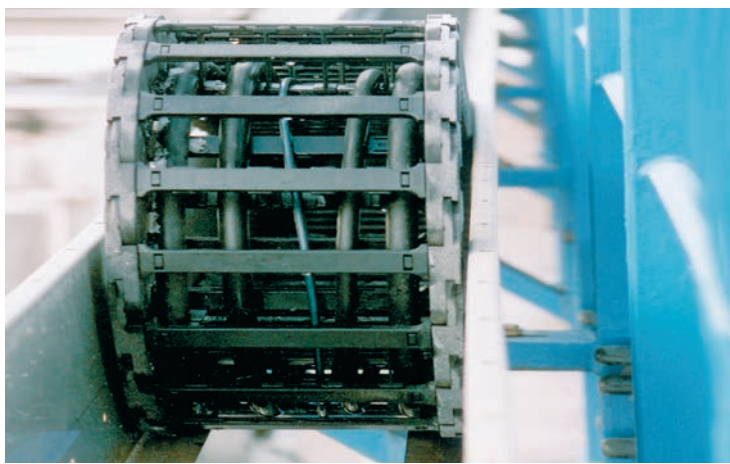

Travel up to 195 m with the igus® System E4, safely guided in an igus® steel trough



# Steel Guide Trough | C-profile lengths

C-profile length according to dim.  $B_{Ri}$



94.30  
94.31

E4.56			14040/14140/R18840			14240/14340			E6.62		
Width index e-chain*	$B_{Ri}$ [mm]	Part No. Installation set	Width index e-chain*	$B_{Ri}$ [mm]	Part No. Installation set	Width index e-chain*	$B_{Ri}$ [mm]	Part No. Installation set	Width index e-chain*	$B_{Ri}$ [mm]	Part No. Installation set
.05	89	upon request	.05	81	upon request	.05	81	upon request	.05	91	upon request
.06	104	94.50.225	.06	96	upon request	.06	99	upon request	.06	109	94.50.225
.07	114	94.50.225	.07	106	94.50.225	.07	106	94.50.225	.07	116	94.50.225
.08	121	94.50.225	.10	131	94.50.250	.087	119	94.50.250	.087	128	94.50.250
.10	139	94.50.250	.11	144	94.50.275	.10	131	94.50.250	.10	141	94.50.250
.11	152	94.50.275	.12	156	94.50.275	.11	139	94.50.250	.11	149	94.50.275
.12	164	94.50.275	.13	169	94.50.300	.112	144	94.50.275	.112	153	94.50.275
.13	177	94.50.300	.15	181	94.50.300	.12	156	94.50.275	.12	166	94.50.275
.15	189	94.50.300	.16	194	94.50.325	.137	169	94.50.300	.137	178	94.50.300
.16	202	94.50.325	.17	206	94.50.325	.15	181	94.50.300	.15	191	94.50.300
.17	214	94.50.325	.18	219	94.50.350	.162	194	94.50.325	.162	203	94.50.325
.18	227	94.50.350	.20	231	94.50.350	.17	199	94.50.325	.17	209	94.50.325
.20	239	94.50.350	.21	244	94.50.375	.18	206	94.50.325	.18	216	94.50.325
.21	252	94.50.375	.22	256	94.50.375	.187	219	94.50.350	.187	228	94.50.350
.22	264	94.50.375	.23	269	94.50.400	.20	231	94.50.350	.20	241	94.50.350
.23	277	94.50.400	.25	281	94.50.400	.212	244	94.50.375	.212	253	94.50.375
.25	289	94.50.400	.26	294	94.50.425	.23	256	94.50.375	.23	266	94.50.375
.26	302	94.50.425	.27	306	94.50.425	.237	269	94.50.400	.237	278	94.50.400
.27	314	94.50.425	.28	319	94.50.450	.25	281	94.50.400	.25	291	94.50.400
.28	327	94.50.450	.30	331	94.50.450	.262	294	94.50.425	.262	303	94.50.425
.30	339	94.50.450	.31	344	94.50.475	.28	306	94.50.425	.28	316	94.50.425
.31	352	94.50.475	.32	356	94.50.475	.29	319	94.50.450	.29	328	94.50.450
.32	364	94.50.475	.33	369	94.50.500	.30	331	94.50.450	.30	341	94.50.450
.33	377	94.50.500	.35	381	94.50.500	.312	344	94.50.475	.312	353	94.50.475
.35	389	94.50.500	.36	394	94.50.525	.325	356	94.50.475	.325	366	94.50.475
.36	402	94.50.525	.37	406	94.50.525	.337	369	94.50.500	.337	378	94.50.500
.37	414	94.50.525	.38	419	94.50.550	.350	381	94.50.500	.350	391	94.50.500
.38	427	94.50.550	.40	431	94.50.550	.362	394	94.50.525	.362	403	94.50.525
.40	439	94.50.550	.41	444	94.50.575	.375	406	94.50.525	.375	416	94.50.525
.41	452	94.50.575	.42	456	94.50.575	.384	419	94.50.550	.387	428	94.50.550
.42	464	94.50.575	.43	469	94.50.600	.400	431	94.50.550	.400	441	94.50.550
.43	477	94.50.600	.45	481	94.50.600						
.45	489	94.50.600	.46	494	94.50.625						
.46	502	94.50.625	.47	506	94.50.625						
.47	514	94.50.625	.48	519	94.50.650						
.48	527	94.50.650	.50	531	94.50.650						
.50	539	94.50.650	.51	544	94.50.675						
.51	552	94.50.675	.52	556	94.50.675						
.52	564	94.50.675	.53	569	94.50.700						
.53	577	94.50.700	.55	581	94.50.700						
.55	589	94.50.700	.60	631	94.50.750						
.60	639	94.50.750									



180 m travel, 30 kg/m fill weight. Two igus® E4 rol e-chains®



For the following  
igus® Series

E4/light

● 14550/14650/R19050



**Option:**

With reinforced  
mounting angles for  
extreme applications

**Note:** The inner width of the guide trough and the C-profile length of the assembly kit can differ according to the bracket you choose. Please call us!

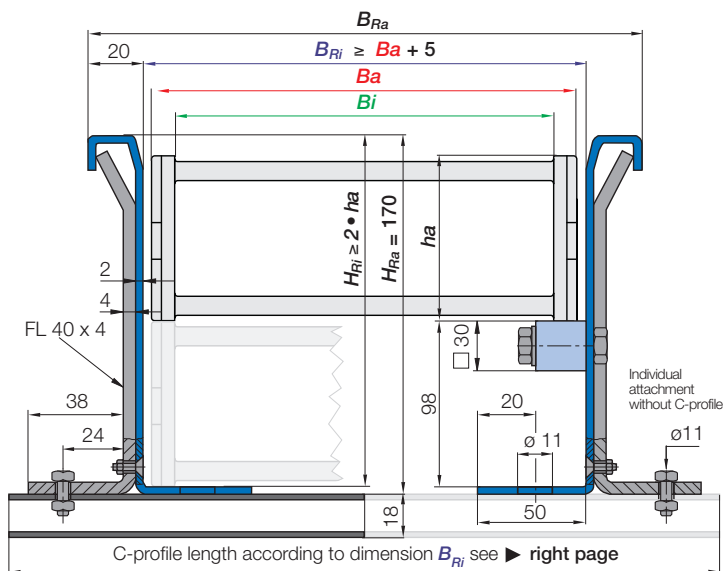

## Steel Guide Trough | Complete sets

Trough side parts sets	Part No.	Weight
Set of 2 trough side parts, <b>without</b> glide bars, 2 m section	94.14550.30.E <sup>1)</sup> / E44 <sup>2)</sup> / E45 <sup>3)</sup>	~ 14,70 kg
Set of 2 trough side parts, <b>with</b> glide bars, 2 m section	94.14550.31.E <sup>1)</sup> / E44 <sup>2)</sup> / E45 <sup>3)</sup>	~ 19,00 kg
Installation sets - consisting of part		
1 Installation set <b>without</b> C-profile	94.50	~ 0,58 kg
1 Installation set <b>with</b> C-profile (C-profile length according to dimension $B_{Ri}$ )	94.50.XXX*	upon request

\* Please add the C-profile length as shown on the tables on the right page. Example: 94.50.350

## Steel Guide Trough | Components as single parts

Single parts, trough	Part No.	Weight
1 Trough side part, individual, 2 m section	94.14550.11.E <sup>1)</sup> / E44 <sup>2)</sup> / E45 <sup>3)</sup>	~ 7,35 kg
1 Glide bar, individual, each 2 m	93.01	~ 1,68 kg
1 Glide bar, individual, each 2 m + 11 screw sets	93.20	~ 2,22 kg
Single parts, installation set		
11 Screw sets for 2 m sections	93.21	~ 0,54 kg
1 Clamping bracket, individual	94.51	~ 0,25 kg
1 Countersunk-head screw M6 x 14, individual	92.53	
1 Hexagon nut M6, individual	92.54	
1 Hexagon-head screw M10 x 16, individual	92.55	
1 Glide nut M10, individual	92.56	
1 C-profile, individual (C-profile length according to dimension $B_{Ri}$ )	92.52.XXX*.E <sup>1)</sup>	~ 0,90 kg/m
Additional option for simple fastening of the e-chain® without drilling		
1 Set Fixed end module (Detailed information ► page 692)	94.14550.80.01	~ 14,70 kg

\* Please add the C-profile length as shown on the tables on the right page. Example: 92.52.350.E

- 1) Trough side parts + C-profile - Also available in stainless steel V2A, material 1.4301 (AISI 304). Please add index ".E" to the Part No.
- 2) Trough side parts - Also available in stainless steel V4A, material 1.4404 (AISI 316L). Please add index ".E44" to the Part No.
- 3) Trough side parts - Also available in stainless steel V4A, material 1.4571 (AISI 316Ti). Please add index ".E45" to the Part No.

# Steel Guide Trough | C-profile lengths

C-profile length according to dim.  $B_{Ri}$



94.14550.30  
94.14550.31

## 14550/14650/R19050

Width index e-chain*	$B_{Ri}$ [mm]	Part No. Installation set
.05	82	upon request
.06	97	upon request
.07	107	94.50 <a href="#">225</a>
.08	119	94.50 <a href="#">250</a>
.10	132	94.50 <a href="#">250</a>
.11	144	94.50 <a href="#">275</a>
.12	157	94.50 <a href="#">275</a>
.13	169	94.50 <a href="#">300</a>
.15	182	94.50 <a href="#">300</a>
.16	194	94.50 <a href="#">325</a>
.17	207	94.50 <a href="#">325</a>
.18	219	94.50 <a href="#">350</a>
.20	232	94.50 <a href="#">350</a>
.21	244	94.50 <a href="#">375</a>
.22	257	94.50 <a href="#">375</a>
.23	269	94.50 <a href="#">400</a>
.25	282	94.50 <a href="#">400</a>
.26	294	94.50 <a href="#">425</a>
.27	307	94.50 <a href="#">425</a>
.28	319	94.50 <a href="#">450</a>
.30	332	94.50 <a href="#">450</a>
.31	344	94.50 <a href="#">475</a>
.32	357	94.50 <a href="#">475</a>
.33	369	94.50 <a href="#">500</a>
.35	382	94.50 <a href="#">500</a>
.36	394	94.50 <a href="#">525</a>
.37	407	94.50 <a href="#">525</a>
.38	419	94.50 <a href="#">550</a>
.40	432	94.50 <a href="#">550</a>
.41	444	94.50 <a href="#">575</a>
.42	457	94.50 <a href="#">575</a>
.43	469	94.50 <a href="#">600</a>
.45	482	94.50 <a href="#">600</a>
.46	494	94.50 <a href="#">625</a>
.47	507	94.50 <a href="#">625</a>
.48	519	94.50 <a href="#">650</a>
.50	532	94.50 <a href="#">650</a>
.51	544	94.50 <a href="#">675</a>
.52	557	94.50 <a href="#">675</a>
.53	569	94.50 <a href="#">700</a>
.55	582	94.50 <a href="#">700</a>
.60	632	94.50 <a href="#">750</a>



System E4 with extension links -long travel application onboard West Navigator (Norway)



For the following  
igus® Series

E4.1

● E4.80

E4/light

● 15050/15150/R19850

● 15250/15350

E6

● E6.80



**Option:**

With reinforced  
mounting angles for  
extreme applications

**Note:** The inner width of the guide trough and the C-profile length of the assembly kit can differ according to the bracket you choose. Please call us!

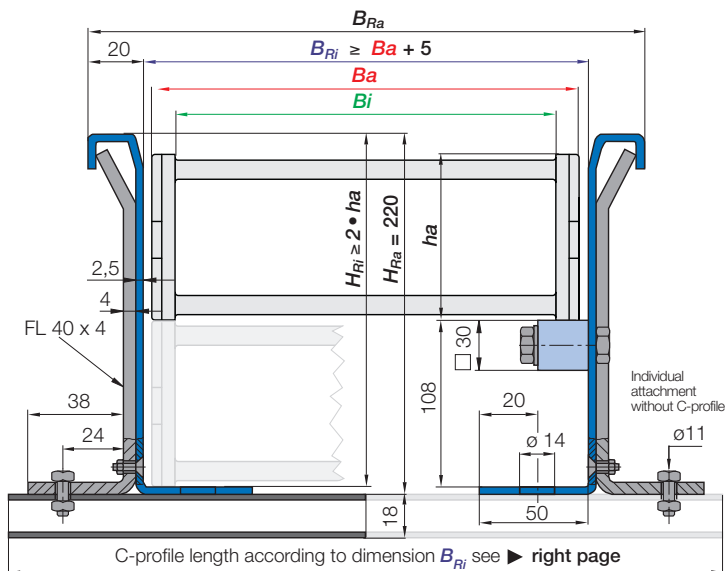

## Steel Guide Trough | Complete sets

Trough side parts sets	Part No.	Weight
Set of 2 trough side parts, <b>without</b> glide bars, 2 m section	96.30.E <sup>1)</sup> / E44 <sup>2)</sup> / E45 <sup>3)</sup>	= 22,80 kg
Set of 2 trough side parts, <b>with</b> glide bars, 2 m section	96.31.E <sup>1)</sup> / E44 <sup>2)</sup> / E45 <sup>3)</sup>	= 27,20 kg
Installation sets - consisting of part		
1 Installation set <b>without</b> C-profile	96.50	= 0,72 kg
1 Installation set <b>with</b> C-profile (C-profile length according to dimension $B_{Ri}$ )	96.50.XXX*	upon request

\* Please add the C-profile length as shown on the tables on the right page. Example: 96.50.375

## Steel Guide Trough | Components as single parts

Single parts, trough	Part No.	Weight
1 Trough side part, individual, 2 m section	96.11.E <sup>1)</sup> / E44 <sup>2)</sup> / E45 <sup>3)</sup>	= 11,4 kg
1 Glide bar, individual, each 2 m	93.01	= 1,68 kg
1 Glide bar, individual, each 2 m + 11 screw sets	93.20	= 2,22 kg
Single parts, installation set		
11 Screw sets for 2 m sections	93.21	= 0,54 kg
1 Clamping bracket, individual	96.51	= 0,31 kg
1 Countersunk-head screw M6 x 14, individual	92.53	
1 Hexagon nut M6, individual	92.54	
1 Hexagon-head screw M10 x 16, individual	92.55	
1 Glide nut M10, individual	92.56	
1 C-profile, individual (C-profile length according to dimension $B_{Ri}$ )	92.52.XXX*.E <sup>1)</sup>	= 0,90 kg/m
Additional option for simple fastening of the e-chain® without drilling		
1 Set Fixed end module (Detailed information ► page 692)	96.80.01	= 22,80 kg

\* Please add the C-profile length as shown on the tables on the right page. Example: 92.52.375.E

1) Trough side parts + C-profile - Also available in stainless steel V2A, material 1.4301 (AISI 304). Please add index ".E" to the Part No.

2) Trough side parts - Also available in stainless steel V4A, material 1.4404 (AISI 316L). Please add index ".E44" to the Part No.

3) Trough side parts - Also available in stainless steel V4A, material 1.4571 (AISI 316Ti). Please add index ".E45" to the Part No.

# Steel Guide Trough | C-profile lengths

C-profile length according to dim.  $B_{Ri}$



96.30  
96.31

E4.80			15050/15150/R19850			15250/15350			E6.80		
Width index e-chain*	$B_{Ri}$ [mm]	Part No. Installation set	Width index e-chain*	$B_{Ri}$ [mm]	Part No. Installation set	Width index e-chain*	$B_{Ri}$ [mm]	Part No. Installation set	Width index e-chain*	$B_{Ri}$ [mm]	Part No. Installation set
.05	105	96.50. 225	.05	85	upon request	.05	85	upon request	.05	105	96.50. 225
.06	120	96.50. 250	.06	100	upon request	.06	103	96.50. 225	.06	120	96.50. 250
.07	130	96.50. 250	.07	110	96.50. 225	.07	110	96.50. 225	.07	130	96.50. 250
.10	155	96.50. 275	.10	135	96.50. 250	.087	122	96.50. 250	.10	155	96.50. 275
.11	168	96.50. 300	.11	148	96.50. 275	.09	132	96.50. 250	.11	167	96.50. 300
.12	180	96.50. 300	.12	160	96.50. 275	.10	135	96.50. 250	.12	180	96.50. 300
.13	193	96.50. 325	.13	173	96.50. 300	.11	143	96.50. 275	.13	192	96.50. 325
.15	205	96.50. 325	.15	185	96.50. 300	.112	148	96.50. 275	.15	205	96.50. 325
.16	218	96.50. 350	.16	198	96.50. 325	.12	160	96.50. 275	.16	217	96.50. 350
.17	230	96.50. 350	.17	210	96.50. 325	.137	172	96.50. 300	.17	230	96.50. 350
.18	243	96.50. 375	.18	223	96.50. 350	.15	185	96.50. 300	.18	242	96.50. 375
.20	255	96.50. 375	.20	235	96.50. 350	.162	198	96.50. 325	.20	255	96.50. 375
.21	268	96.50. 400	.21	248	96.50. 375	.17	203	96.50. 325	.21	267	96.50. 400
.22	280	96.50. 400	.22	260	96.50. 375	.18	210	96.50. 325	.22	280	96.50. 400
.23	293	96.50. 425	.23	273	96.50. 400	.187	223	96.50. 350	.23	292	96.50. 425
.25	305	96.50. 425	.25	285	96.50. 400	.20	235	96.50. 350	.25	305	96.50. 425
.26	318	96.50. 450	.26	298	96.50. 425	.212	248	96.50. 375	.26	317	96.50. 450
.27	330	96.50. 450	.27	310	96.50. 425	.23	260	96.50. 375	.27	330	96.50. 450
.28	343	96.50. 475	.28	323	96.50. 450	.237	273	96.50. 400	.28	342	96.50. 475
.30	355	96.50. 475	.30	335	96.50. 450	.25	285	96.50. 400	.30	355	96.50. 475
.31	368	96.50. 500	.31	348	96.50. 475	.262	298	96.50. 425	.31	367	96.50. 500
.32	380	96.50. 500	.32	360	96.50. 475	.28	310	96.50. 425	.32	380	96.50. 500
.33	393	96.50. 525	.33	373	96.50. 500	.29	323	96.50. 450	.33	392	96.50. 525
.35	405	96.50. 525	.35	385	96.50. 500	.30	335	96.50. 450	.35	405	96.50. 525
.36	418	96.50. 550	.36	398	96.50. 525	.312	348	96.50. 475	.36	417	96.50. 550
.37	430	96.50. 550	.37	410	96.50. 525	.325	360	96.50. 475	.37	430	96.50. 550
.38	443	96.50. 575	.38	423	96.50. 550	.337	373	96.50. 500	.38	442	96.50. 575
.40	455	96.50. 575	.40	435	96.50. 550	.350	385	96.50. 500	.40	455	96.50. 575
.41	468	96.50. 600	.41	448	96.50. 575	.362	398	96.50. 525	.41	470	96.50. 600
.42	480	96.50. 600	.42	460	96.50. 575	.375	410	96.50. 525	.42	480	96.50. 600
.43	493	96.50. 625	.43	473	96.50. 600	.387	423	96.50. 550	.43	492	96.50. 625
.45	505	96.50. 625	.45	485	96.50. 600	.400	435	96.50. 550	.45	505	96.50. 625
.46	518	96.50. 650	.46	498	96.50. 625				.46	517	96.50. 650
.47	530	96.50. 650	.47	510	96.50. 625				.47	530	96.50. 650
.48	543	96.50. 675	.48	523	96.50. 650				.48	542	96.50. 675
.50	555	96.50. 675	.50	535	96.50. 650				.50	555	96.50. 675
.51	568	96.50. 700	.51	548	96.50. 675				.51	567	96.50. 700
.52	580	96.50. 700	.52	560	96.50. 675				.52	580	96.50. 700
.53	593	96.50. 725	.53	573	96.50. 700				.53	592	96.50. 725
.55	605	96.50. 725	.55	585	96.50. 700				.55	605	96.50. 725
.60	655	96.50. 775	.60	635	96.50. 750				.60	655	96.50. 775



igus® E4 rol e-chain® and steel guide trough





For the following  
igus® Series

E4.1

● E4.112/H4.112/R4.112

E4/light

● 1640/R1608



**Option:**

With reinforced  
mounting angles for  
extreme applications

**Note:** The inner width of the guide trough and the C-profile length of the assembly kit can differ according to the bracket you choose. Please call us!

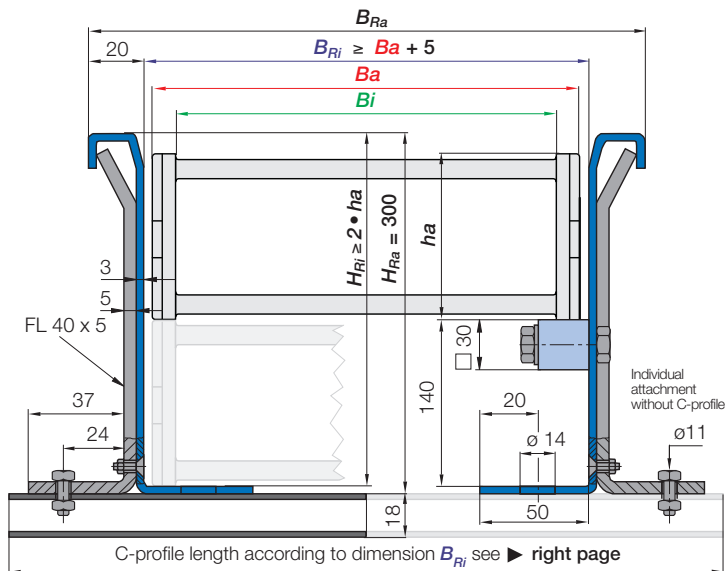

## Steel Guide Trough | Complete sets

Trough side parts sets	Part No.	Weight
Set of 2 trough side parts, <b>without</b> glide bars, 2 m section	98.30.E <sup>1)</sup> / E44 <sup>2)</sup> / E45 <sup>3)</sup>	= 34,60 kg
Set of 2 trough side parts, <b>with</b> glide bars, 2 m section	98.31.E <sup>1)</sup> / E44 <sup>2)</sup> / E45 <sup>3)</sup>	= 39,00 kg
Installation sets - consisting of part		
1 Installation set <b>without</b> C-profile	98.50	= 1,16 kg
1 Installation set <b>with</b> C-profile (C-profile length according to dimension $B_{Ri}$ )	98.50.XXX*	upon request

\* Please add the C-profile length as shown on the tables on the right page. Example: 98.50.350

## Steel Guide Trough | Components as single parts

Single parts, trough	Part No.	Weight
1 Trough side part, individual, 2 m section	98.11.E <sup>1)</sup> / E44 <sup>2)</sup> / E45 <sup>3)</sup>	= 17,3 kg
1 Glide bar, individual, each 2 m	93.01	= 1,68 kg
1 Glide bar, individual, each 2 m + 11 screw sets	93.20	= 2,22 kg
Single parts, installation set		
11 Screw sets for 2 m sections	93.21	= 0,54 kg
1 Clamping bracket, individual	98.51	= 0,52 kg
1 Countersunk-head screw M8 x 20, individual	92.05	
1 Hexagon nut M8, individual	92.04	
1 Hexagon-head screw M10 x 16, individual	92.55	
1 Glide nut M10, individual	92.56	
1 C-profile, individual (C-profile length according to dimension $B_{Ri}$ )	92.52.XXX*.E <sup>1)</sup>	= 0,90 kg/m
Additional option for simple fastening of the e-chain® without drilling		
1 Set Fixed end module (Detailed information ► page 692)	98.80.01	= 34,6 kg

\* Please add the C-profile length as shown on the tables on the right page. Example: 92.52.375.E

1) Trough side parts + C-profile - Also available in stainless steel V2A, material 1.4301 (AISI 304). Please add index ".E" to the Part No.

2) Trough side parts - Also available in stainless steel V4A, material 1.4404 (AISI 316L). Please add index ".E44" to the Part No.

3) Trough side parts - Also available in stainless steel V4A, material 1.4571 (AISI 316Ti). Please add index ".E45" to the Part No.

# Steel Guide Trough | C-profile lengths

C-profile length according to dim.  $B_{Ri}$



98.30  
98.31

## E4.112/H4.112/R4.112

Width index e-chain*	$B_{Ri}$ [mm]	Part No. Installation set
.05	107	98.50. 225
.06	122	98.50. 250
.07	132	98.50. 250
.10	157	98.50. 275
.11	169	98.50. 300
.12	182	98.50. 300
.13	194	98.50. 325
.15	207	98.50. 325
.16	219	98.50. 350
.17	232	98.50. 350
.18	244	98.50. 375
.20	257	98.50. 375
.21	269	98.50. 400
.22	282	98.50. 400
.23	294	98.50. 425
.25	307	98.50. 425
.26	319	98.50. 450
.27	332	98.50. 450
.28	344	98.50. 475
.30	357	98.50. 475
.31	369	98.50. 500
.32	382	98.50. 500
.33	394	98.50. 525
.35	407	98.50. 525
.36	419	98.50. 550
.37	432	98.50. 550
.38	444	98.50. 575
.40	457	98.50. 575
.41	469	98.50. 600
.42	482	98.50. 600
.43	494	98.50. 625
.45	507	98.50. 625
.46	519	98.50. 650
.47	532	98.50. 650
.48	544	98.50. 675
.50	557	98.50. 675
.51	569	98.50. 700
.52	582	98.50. 700
.53	594	98.50. 725
.55	607	98.50. 725
.60	657	98.50. 775

## 1640/R1608

Width index e-chain*	$B_{Ri}$ [mm]	Part No. Installation set
.05	89	upon request
.06	104	98.50. 225
.07	114	98.50. 250
.08	124	98.50. 250
.10	139	98.50. 275
.11	151	98.50. 275
.12	164	98.50. 300
.13	176	98.50. 300
.15	189	98.50. 325
.16	201	98.50. 325
.17	214	98.50. 350
.18	226	98.50. 350
.20	239	98.50. 375
.21	251	98.50. 375
.22	264	98.50. 400
.23	276	98.50. 400
.25	289	98.50. 425
.26	301	98.50. 425
.27	314	98.50. 450
.28	326	98.50. 450
.30	339	98.50. 475
.31	351	98.50. 475
.32	364	98.50. 500
.33	376	98.50. 500
.35	389	98.50. 525
.36	401	98.50. 525
.37	414	98.50. 550
.38	426	98.50. 550
.40	439	98.50. 575
.41	451	98.50. 575
.42	464	98.50. 600
.43	476	98.50. 600
.45	489	98.50. 625
.46	501	98.50. 625
.47	514	98.50. 650
.48	526	98.50. 650
.50	539	98.50. 675
.51	551	98.50. 675
.52	564	98.50. 700
.53	576	98.50. 700
.55	589	98.50. 725
.60	639	98.50. 775



Rig skidding application on the Claymore, North Sea

# Steel Guide Trough | 90.30 | 90.31 | Heavy-Duty

Trough height: 480 mm | Delivery program



For the following  
igus® Series

E4.1

- 800
- 840



This igus® steel guide trough has reinforced mounting angles for extreme applications

**Note:** The inner width of the guide trough and the C-profile length of the assembly kit can differ according to the bracket you choose. Please call us!

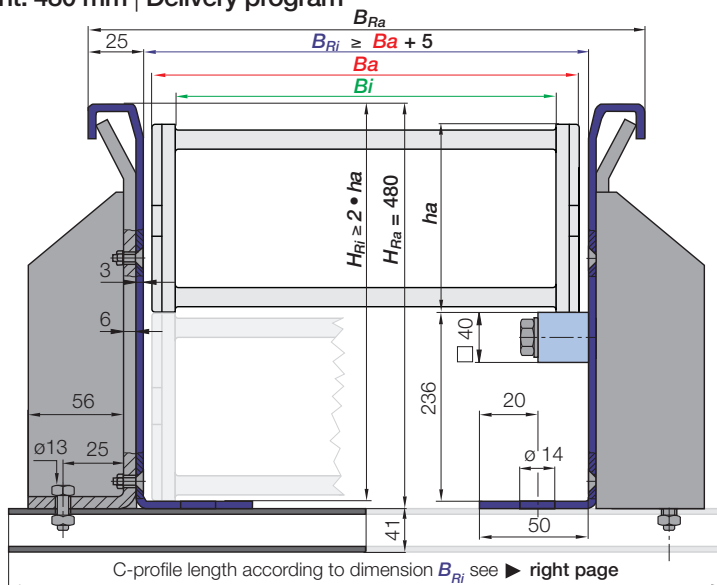

## Steel Guide Trough | Complete sets

Trough side parts sets	Part No.	Weight
Set of 2 trough side parts, <b>without</b> glide bars, 2 m section	90.30.E <sup>1)</sup> / E44 <sup>2)</sup> / E45 <sup>3)</sup>	≈ 53,40 kg
Set of 2 trough side parts, <b>with</b> glide bars, 2 m section	90.31.E <sup>1)</sup> / E44 <sup>2)</sup> / E45 <sup>3)</sup>	≈ 59,40 kg
Installation sets - consisting of part		
1 Installation set <b>without</b> C-profile	90.50	≈ 0,41 kg
1 Installation set <b>with</b> C-profile (C-profile length according to dimension $B_{Ri}$ )	90.50.XXX*	upon request

\* Please add the C-profile length as shown on the tables on the right page. Example: 90.50.450

## Steel Guide Trough | Components as single parts

Single parts, trough	Part No.	Weight
1 Trough side part, individual, 2 m section	90.11.E <sup>1)</sup> / E44 <sup>2)</sup> / E45 <sup>3)</sup>	≈ 26,7 kg
1 Glide bar, individual, each 2 m	90.01	≈ 1,68 kg
1 Glide bar, individual, each 2 m + 11 screw sets	90.20	≈ 2,22 kg
Single parts, installation set		
11 Screw sets for 2 m sections	90.21	≈ 0,54 kg
1 Clamping bracket, individual	90.51	≈ 0,52 kg
1 Countersunk-head screw M8 x 25, individual	MAT0040014	
1 Hexagon nut M8, individual	MAT0040012	
1 Hexagon-head screw M12 x 30, individual	MAT0040384	
1 Glide nut M12, individual	MAT0040385	
1 C-profile, individual (C-profile length according to dimension $B_{Ri}$ )	IE70.41-41.XXX*.E <sup>1)</sup>	≈ 0,90 kg/m
Additional option for simple fastening of the e-chain® without drilling		
1 Set Fixed end module (Detailed information ► page 692)	90.80.01	≈ 53,40 kg

\* Please add the C-profile length as shown on the tables on the right page. Example: 92.52.450.E

- 1) Trough side parts + C-profile - Also available in stainless steel V2A, material 1.4301 (AISI 304). Please add index ".E" to the Part No.
- 2) Trough side parts - Also available in stainless steel V4A, material 1.4404 (AISI 316L). Please add index ".E44" to the Part No.
- 3) Trough side parts - Also available in stainless steel V4A, material 1.4571 (AISI 316Ti). Please add index ".E45" to the Part No.



# Support Tray | Introduction | Advantages

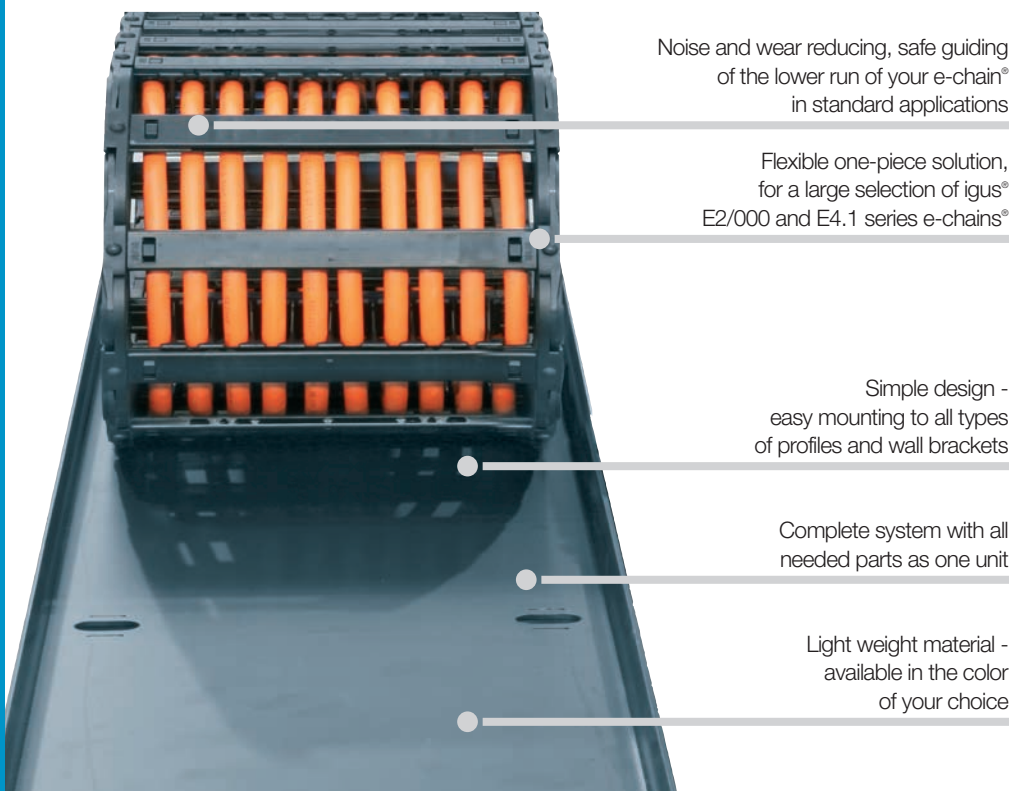

Noise and wear reducing, safe guiding of the lower run of your e-chain® in standard applications

Flexible one-piece solution, for a large selection of igus® E2/000 and E4.1 series e-chains®

Simple design - easy mounting to all types of profiles and wall brackets

Complete system with all needed parts as one unit

Light weight material - available in the color of your choice

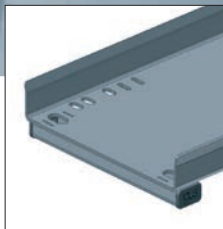

Option 01 - with connection-rail

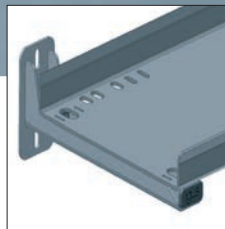

Option 02 - with bracket

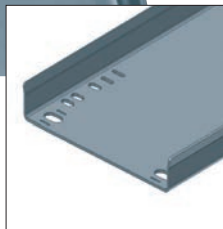

Option 03 - without rail (upon request)

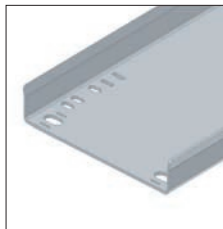

Option 04 - customized (upon request)

## For support of the lower run | Support tray tool kit

Simple one-piece support trays for the lower e-chain® run, according with your requirements and specification. Your width, height and color - we supply the fitting e-chain®, together with the support tray system. Ready to install onto your machine or application. Save on procurement and design time.

- Complete system, ready to install
- No more costly self-made designs
- Easy installation onto your machine, on profiles or wall-mount brackets
- igus® support tray - in 2 types and 4 options available
- For many widths available from stock, with many mounting possibilities



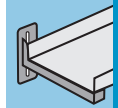

Support tray Part No.	Width e-chain**	Outer trough width $B_{Ra}$ [mm]	Inner trough width $B_{Ri}$ [mm]	Material	Page
-----------------------	-----------------	----------------------------------	----------------------------------	----------	------



### Support Tray - Type 01 for Series:

- 2400/2450/2480/2500 ● 2600/2650/2680/2700
- E4.21 ● E4.28/R4.28 ● E4.32/H4.32/R4.32 ● E4.38L
- E6.29/R6.29 ● E6.35 ● E6.40/R6.40 ● E61.29

S9.010/011.05.XXXX.0	.05 / .050	89	80	Steel, black	716
S9.010/011.07.XXXX.0	.07 / .070	114	105	Steel, black	716
S9.010/011.10.XXXX.0	.10 / .100	139	130	Steel, black	716
S9.010/011.15.XXXX.0	.15 / .150	185	175	Steel, black	716



### Support Tray - Type 02 for Series:

- 3400/3450/3480/3500
- E4.42/H4.42/R4.42 ● E4.48L ● E4.56/H4.56/R4.56 ● E4.80/H4.80/R4.80
- 14040/14140/R18840 ● 14240/14340 ● 14550/14650/19050
- 15050/15150/R19850 ● 15250/15350
- E6.52/R6.52 ● E6.62 ● E6.80 ● E61.52

S9.020/021.10.XXXX.0	.10 / .100	167	156	Steel, black	718
S9.020/021.15.XXXX.0	.15 / .150	217	206	Steel, black	718
S9.020/021.20.XXXX.0	.20 / .200	267	256	Steel, black	718
S9.020/021.25.XXXX.0	.25 / .250	317	306	Steel, black	718

\*depends on width-index



Support tray with bracket for easy mounting on your application

# Support Tray | Type 01 | Delivery program

Standard-length from stock 1000 mm and 2000 mm



For the following  
igus® Series

- E2/000
- 2400/2450/2480/2500
- 2600/2650/2680/2700
- E4.1
- E4.21
- E4.28/R4.28
- E4.32/H4.32/R4.32
- E4.1 light
- E4.38L
- E6
- E6.29/R6.29
- E6.35
- E6.40/R6.40
- E6
- E61.29

- 1 Support Tray Type 01 - Standard-length from stock 1 m and 2 m
- 2 All connection rails 975 mm
- 3 Bracket for easy mounting on your application

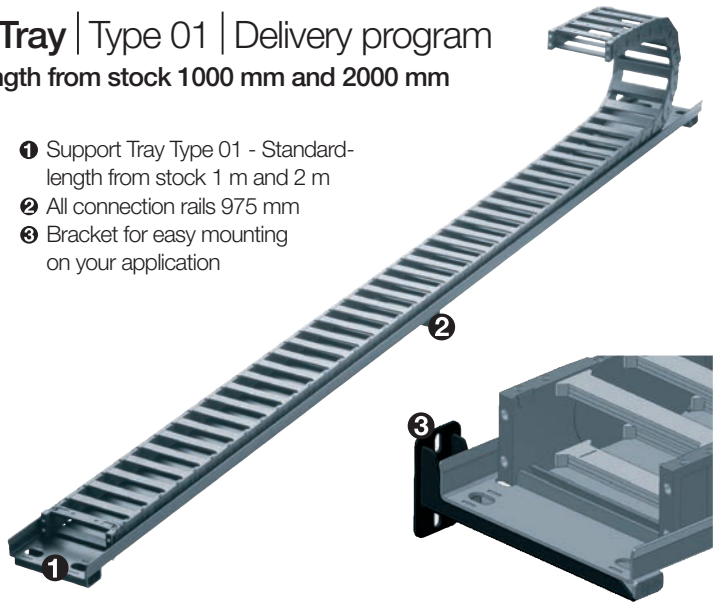

System	Suitable for the following series ▼	Width-index	B <sub>Ra</sub> [mm]	B <sub>Ri</sub> [mm]	Part No. Support-tray, single	Part No. Support-tray with bracket	Part No. single bracket
E2/000	2400/2450/2480/2500	.05	89	80	S9.010.05.[XXXX].0	S9.011.05.[XXXX].0	907.724.05.0
		.07	114	105	S9.010.07.[XXXX].0	S9.011.07.[XXXX].0	907.724.07.0
		.10	139	130	S9.010.10.[XXXX].0	S9.011.10.[XXXX].0	907.724.10.0
E2/000 E4.1 E4.1 light	2600/2650/2680/2700 E4.32/H4.32/R4.32 E4.38L	.05	89	80	S9.010.05.[XXXX].0	S9.011.05.[XXXX].0	907.724.05.0
		.07	114	105	S9.010.07.[XXXX].0	S9.011.07.[XXXX].0	907.724.07.0
		.10	139	130	S9.010.10.[XXXX].0	S9.011.10.[XXXX].0	907.724.10.0
E4.1 E6 E6 E6.1	E4.21 E6.29/R6.29 E6.35 E61.29	.050	89	80	S9.010.05.[XXXX].0	S9.011.05.[XXXX].0	907.724.05.0
		.070	114	105	S9.010.07.[XXXX].0	S9.011.07.[XXXX].0	907.724.07.0
		.100	139	130	S9.010.10.[XXXX].0	S9.011.10.[XXXX].0	907.724.10.0
E4.1 E6	E4.28/R4.28 E6.40/R6.40	.050	89	80	S9.010.05.[XXXX].0	S9.011.05.[XXXX].0	907.724.05.0
		.070	114	105	S9.010.07.[XXXX].0	S9.011.07.[XXXX].0	907.724.07.0
		.100	139	130	S9.010.10.[XXXX].0	S9.011.10.[XXXX].0	907.724.10.0
		.150	185	175	S9.010.15.[XXXX].0	S9.011.15.[XXXX].0	907.724.15.0

Please replace [XXXX] by the standard lengths 1000 or 2000 mm available from stock!

The lengths and widths mentioned here are available from stock in the standard black color. For other lengths, widths and colors, please contact us.



## Order key

Part No. structure 1000 mm **S9.010.07.1000.0**

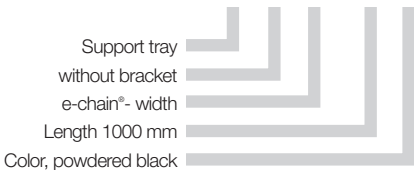

## Order key

Part No. structure 2000 mm **S9.011.15.2000.0**

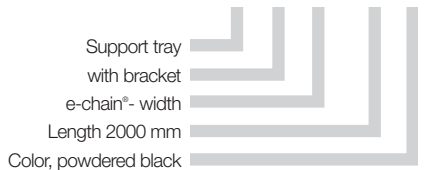

# Support Tray | Type 01 | Dimensions

Dimensions and mounting holes

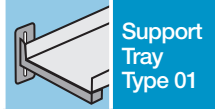

## Support Tray - Type 01

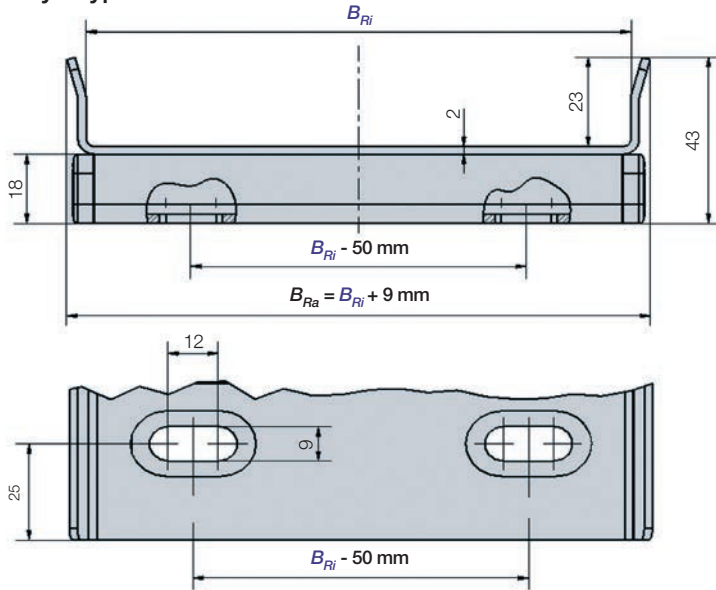

Standard lengths from stock 1 m and 2 m - All connection rails 975 mm

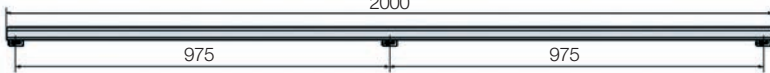

## Bracket - Type 01

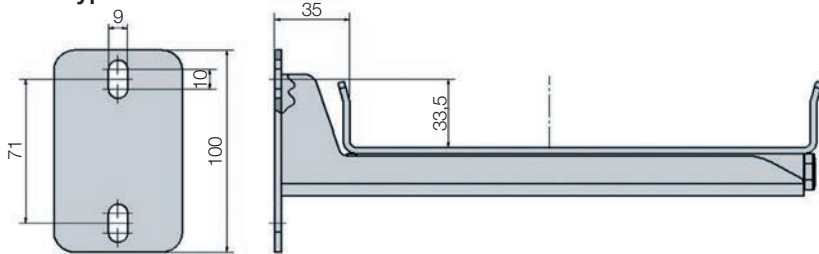



# Support Tray | Type 02 | Delivery program

Standard-length from stock 1000 mm and 2000 mm



For the following  
igus® Series

- E2/000
- 3400/3450/3480/3500
- E4.1
- E4.42/H4.42/R4.42
- E4.56/H4.56/R4.56
- E4.80/H4.80/R4.80
- E4.1 light
- E4.48L
- E4/light
- 14040/14140/R18840
- 14240/14340
- 14550/14650/19050
- 15050/15150/R19850
- 15250/15350
- E6
- E6.56
- E6.62
- E6.80
- E6.1
- E61.52

- 1 Support Tray Type 02 - Standard-length from stock 1 m and 2 m
- 2 All connection rails 975 mm
- 3 Bracket for easy mounting on your application

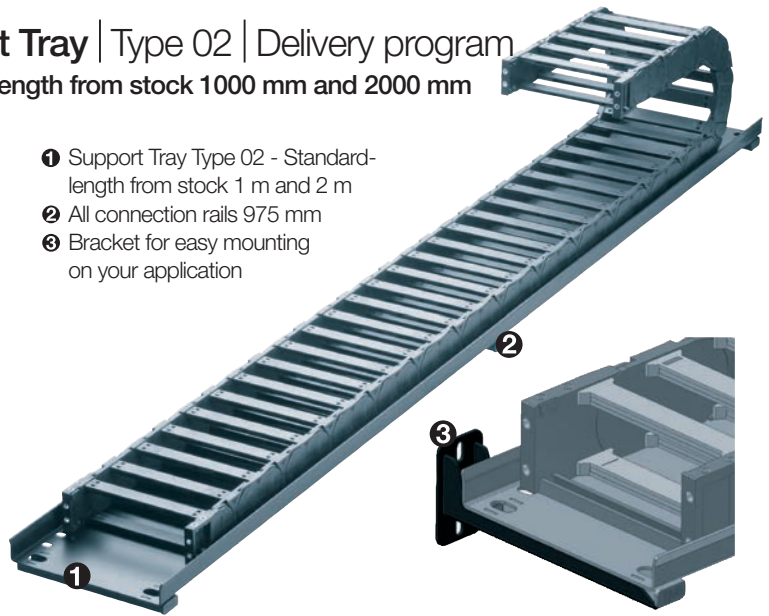

System	Suitable for the following series ▼	Width-index	B <sub>Ra</sub> [mm]	B <sub>Ri</sub> [mm]	Part No. Support-tray, single	Part No. Support-tray with bracket	Part No. single bracket
E4.1	E4.42/H4.42/R4.42	.10	167	156	S9.020.10.[XXXX].0	S9.021.10.[XXXX].0	907.759.010.0
E4.1	E4.56/H4.56/R4.56	.15	217	206	S9.020.15.[XXXX].0	S9.021.15.[XXXX].0	907.759.015.0
E4.1	E4.80/H4.80/R4.80	.20	267	256	S9.020.20.[XXXX].0	S9.021.20.[XXXX].0	907.759.020.0
E4.1 light	E4.48L	.25	317	306	S9.020.25.[XXXX].0	S9.021.25.[XXXX].0	907.759.025.0
E4/light	14040/14140/R18840						
E4/light	14240/14340						
E4/light	14550/14650/19050						
E4/light	15050/15150/R19850						
E4	15250/15350						
E6	E6.62						
E6	E6.80						
E2/000	3400/3450/3480/3500	.100	167	156	S9.020.10.[XXXX].0	S9.021.10.[XXXX].0	907.759.010.0
E6	E6.52/R6.52	.150	217	206	S9.020.15.[XXXX].0	S9.021.15.[XXXX].0	907.759.015.0
E6.1	E61.52	.200	267	256	S9.020.20.[XXXX].0	S9.021.20.[XXXX].0	907.759.020.0
		.250	317	306	S9.020.25.[XXXX].0	S9.021.25.[XXXX].0	907.759.025.0

Please replace [XXXX] by the standard lengths 1000 or 2000 mm available from stock!

The lengths and widths mentioned here are available from stock in the standard black color. For other lengths, widths and colors, please contact us.



## Order key

Part No. structure 1000 mm **S9.020.20.1000.0**

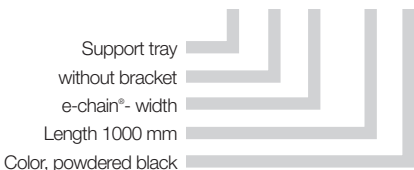

## Order key

Part No. structure 2000 mm **S9.021.20.2000.0**

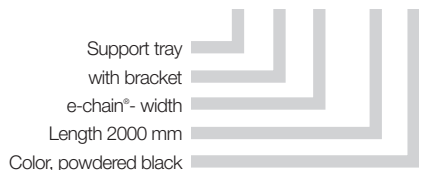

Support Tray - Type 02

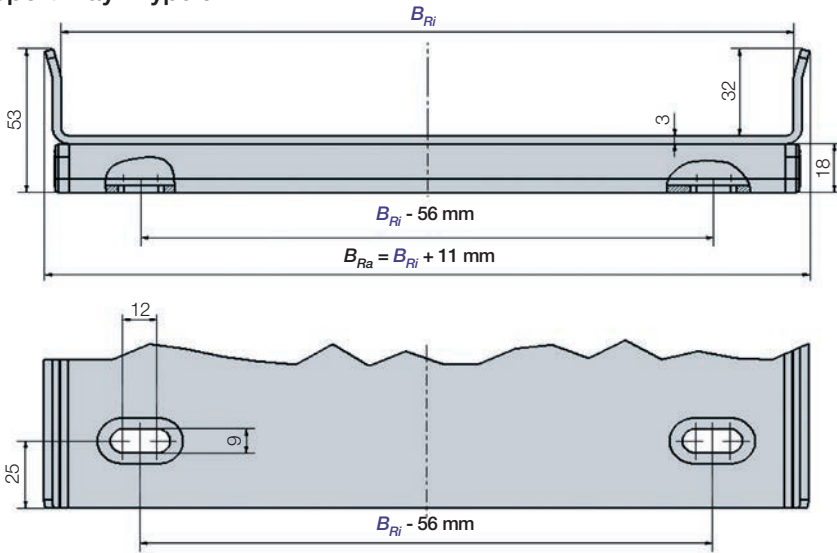

Standard lengths from stock 1 m and 2 m - All connection rails 975 mm

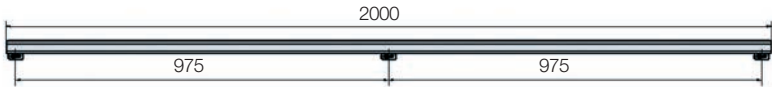

Bracket - Type 02

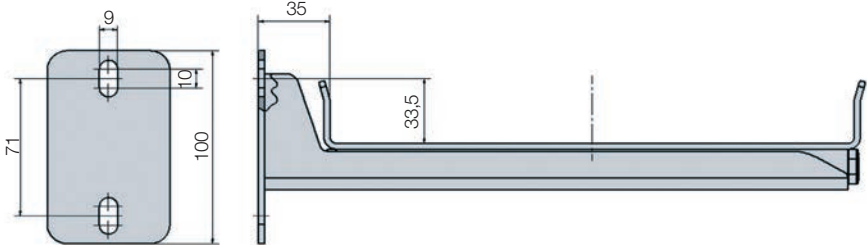

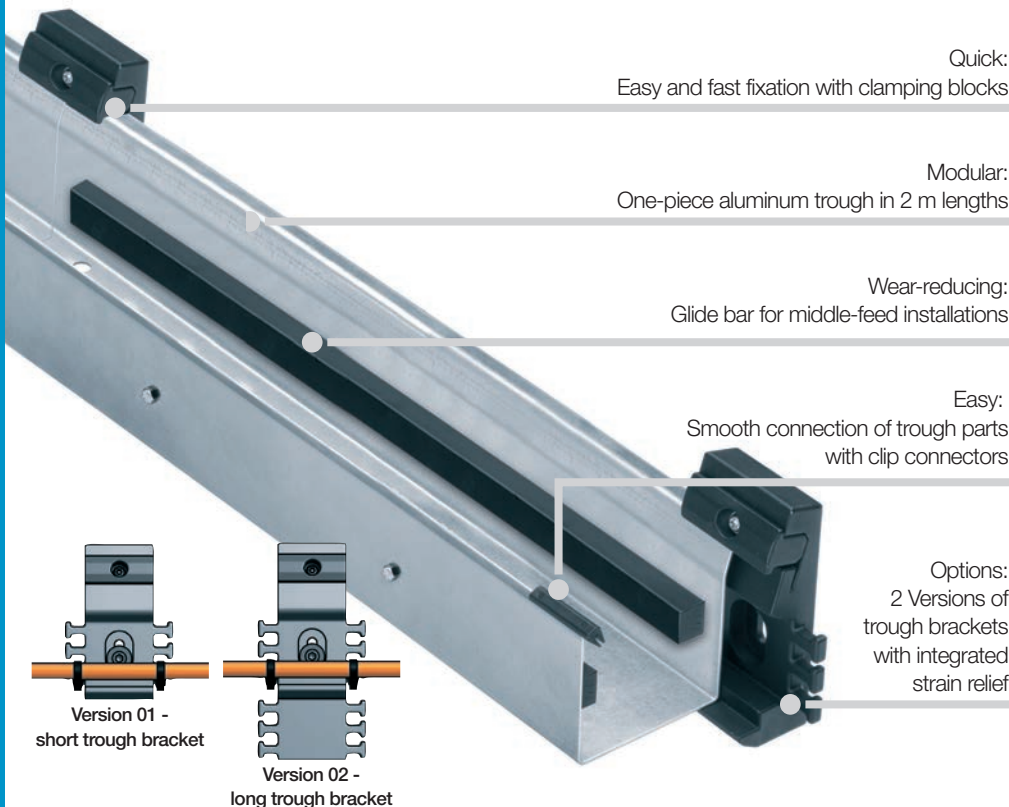

**Quick:**  
Easy and fast fixation with clamping blocks

**Modular:**  
One-piece aluminum trough in 2 m lengths

**Wear-reducing:**  
Glide bar for middle-feed installations

**Easy:**  
Smooth connection of trough parts with clip connectors

**Options:**  
2 Versions of trough brackets with integrated strain relief

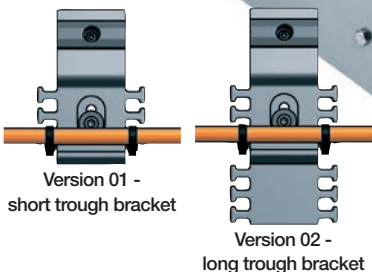

## Economical energy supply for crane girders and indoor cranes - quickly installed as a modular kit solution - guidefast guide trough

The guidefast guide trough is mounted on the side of the crane girder, in case of installation on crane girders, the welding of brackets onto the girder can be omitted. Installation time is kept very short, the guide trough is only attached to the previously installed brackets and then fixed with clamping blocks. The small amount of different components and trough design contribute to a simple installation.

- Save up to 80% installation time compared to standard trough systems
- Fits virtually any standard crane girder
- 2 versions of brackets with integrated strain relief for assembly of static cables on the crane girder - possible  $\pm 5$  mm vertical adjustment of brackets
- Standard trough length of 2.0 m - with or without glide bar
- Suitable for any side-mounted application - not only on cranes
- Easy to install due to preassembled hole patterns of e-chain® brackets
- Standard material: galvanized steel, optional: stainless steel V2A, material 1.4301 (AISI 304) or black powder coating
- Long-term tested to withstand vibration and rough environment

### Typical industries and applications

- Crane manufacturers (mainly indoor cranes)
- Applications where the lateral installation of the guide trough is beneficial

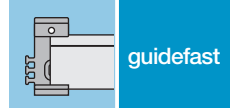

Trough profile* Part No. <b>without</b> glide bar	For E2/000 e-chain*	Inner trough width $B_{Ri}$ [mm]	Complete width [mm]	Material	Page
--	------------------------	-------------------------------------	------------------------	----------	------



**guidefast - without glide bar**  
for E2/000 Series: ● 1500 ● 2500 ● 2700

GF91.30.025.2000	1500.025.	42,5	81	galvanized steel*	722
GF91.30.050.2000	1500.050.	67,5	106	galvanized steel*	722
GF92.30.05. 2000	2500.05.	77	115,5	galvanized steel*	722
GF92.30.07. 2000	2500.07.	97	135,5	galvanized steel*	722
GF92.30.10. 2000	2500.10.	123	161,5	galvanized steel*	722
GF95.30.05. 2000	2700.05.	70	108,5	galvanized steel*	722
GF95.30.07. 2000	2700.07.	95	133,5	galvanized steel*	722
GF95.30.10. 2000	2700.10.	120	158,5	galvanized steel*	722

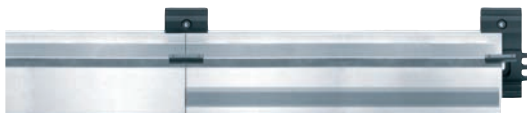

**guidefast - with glide bar**  
for E2/000 Series: ● 1500 ● 2500 ● 2700

GF91.31.025.2000	1500.025.	42,5	81	galvanized steel*	722
GF91.31.050.2000	1500.050.	67,5	106	galvanized steel*	722
GF92.31.05. 2000	2500.05.	77	115,5	galvanized steel*	722
GF92.31.07. 2000	2500.07.	97	135,5	galvanized steel*	722
GF92.31.10. 2000	2500.10.	123	161,5	galvanized steel*	722
GF95.31.05. 2000	2700.05.	70	108,5	galvanized steel*	722
GF95.31.07. 2000	2700.07.	95	133,5	galvanized steel*	722
GF95.31.10. 2000	2700.10.	120	158,5	galvanized steel*	722

\*Standard material: Galvanized steel. Also available as stainless steel-version V2A, material 1.4301 (AISI 304) or black powder coating



guidefast - Attachment to the crane girder through welded bolts or nut/thread, here with version 02 long trough bracket



For the following  
 igus® Series

E2/000

- 1500
- 2500
- 2700

**Components - Set guidefast guide trough**

- ① Trough profile, 2 m section
- ② Glide bar, polymer, 2 m section, optional
- ③ Clip connector, Part No. 908.467

**Components - Set trough bracket**

- A Version 01 - short trough bracket
- B Version 02 - long trough bracket
- C Clamping blocks, Part No. G9.2.10

$B_a$  = Outer e-chain® width

$B_i$  = Inner e-chain® width

$h_a$  = e-chain® outer height

$B_{Ri}$  = Inner trough width =  $B_{Ri} \geq B_a + 4$

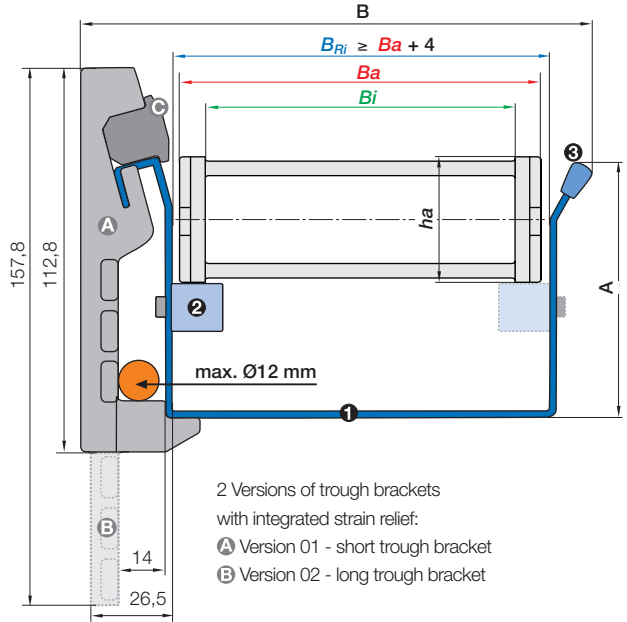

2 Versions of trough brackets  
 with integrated strain relief:

- A Version 01 - short trough bracket
- B Version 02 - long trough bracket



**2 Versions of set trough brackets with integrated strain relief**



Version 01 - short trough bracket Part No. GF9.2.12 with integrated strain relief, possible ± 5 mm vertical adjustment

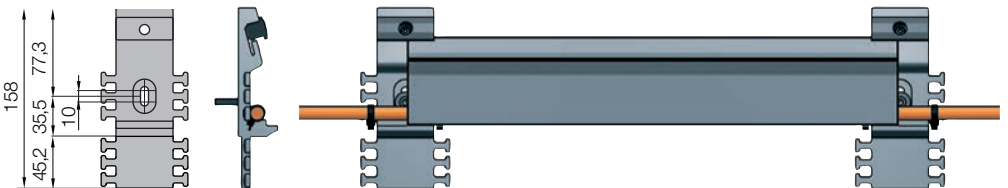

Version 02 - long trough bracket Part No. GF9.2.11 with integrated strain relief, possible ± 5 mm vertical adjustment

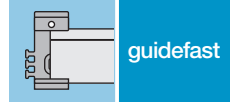

For E2/000 e-chain*	Trough profile* <b>without</b> glide bar	Trough profile* <b>with</b> glide bar	Guidefast basket "short" Version 01	Guidefast basket "long" Version 02	$B_{Ri}$ [mm]	Dim. A [mm]	Dim. B [mm]
	Set incl. clip connectors	Set incl. clip connectors	Set incl. clamping blocks	Set incl. clamping blocks			
1500.025. ▶	GF91.30.025.2000	GF91.31.025.2000	GF9.2.12	GF9.2.11	42.5	61	81
1500.050. ▶	GF91.30.050.2000	GF91.31.050.2000	GF9.2.12	GF9.2.11	67.5	61	106
2500.05. ▶	GF92.30.05. 2000	GF92.31.05. 2000	GF9.2.12	GF9.2.11	77	75	115.5
2500.07. ▶	GF92.30.07. 2000	GF92.31.07. 2000	GF9.2.12	GF9.2.11	97	75	135.5
2500.10. ▶	GF92.30.10. 2000	GF92.31.10. 2000	GF9.2.12	GF9.2.11	123	75	161.5
2700.05. ▶	GF95.30.05. 2000	GF95.31.05. 2000	GF9.2.12	GF9.2.11	70	105	108.5
2700.07. ▶	GF95.30.07. 2000	GF95.31.07. 2000	GF9.2.12	GF9.2.11	95	105	133.5
2700.10. ▶	GF95.30.10. 2000	GF95.31.10. 2000	GF9.2.12	GF9.2.11	120	105	158.5

\*Standard material: Galvanized steel. Also available as stainless steel-version V2A, material 1.4301 (AISI 304) or black powder coating

**A**

Entire support S

Halt support  $S/2$

Note: Tolerances may not to add

1000 1000 1000 2000 2000 2000

**B**

Order example for end feed, travel  $\approx 9,5$  m / guide trough 10 m

Trough profile set **without** glide bar (incl. 5 clip connectors)

Order text: 10 m = 5 x 2 m sections trough profile, without glide bar Part No. GF92.30.07.2000

Trough brackets (incl. 11 clamping blocks, "long" Version 02)

Order text: 11 x trough brackets Part No. GF9.2.11

10 m = 5 x 2 m trough profile, without glide bar + 11 x trough brackets

10 m = 5 x GF92.30.07.2000 + 11 x GF9.2.11



# special solutions long travels

without guide troughs

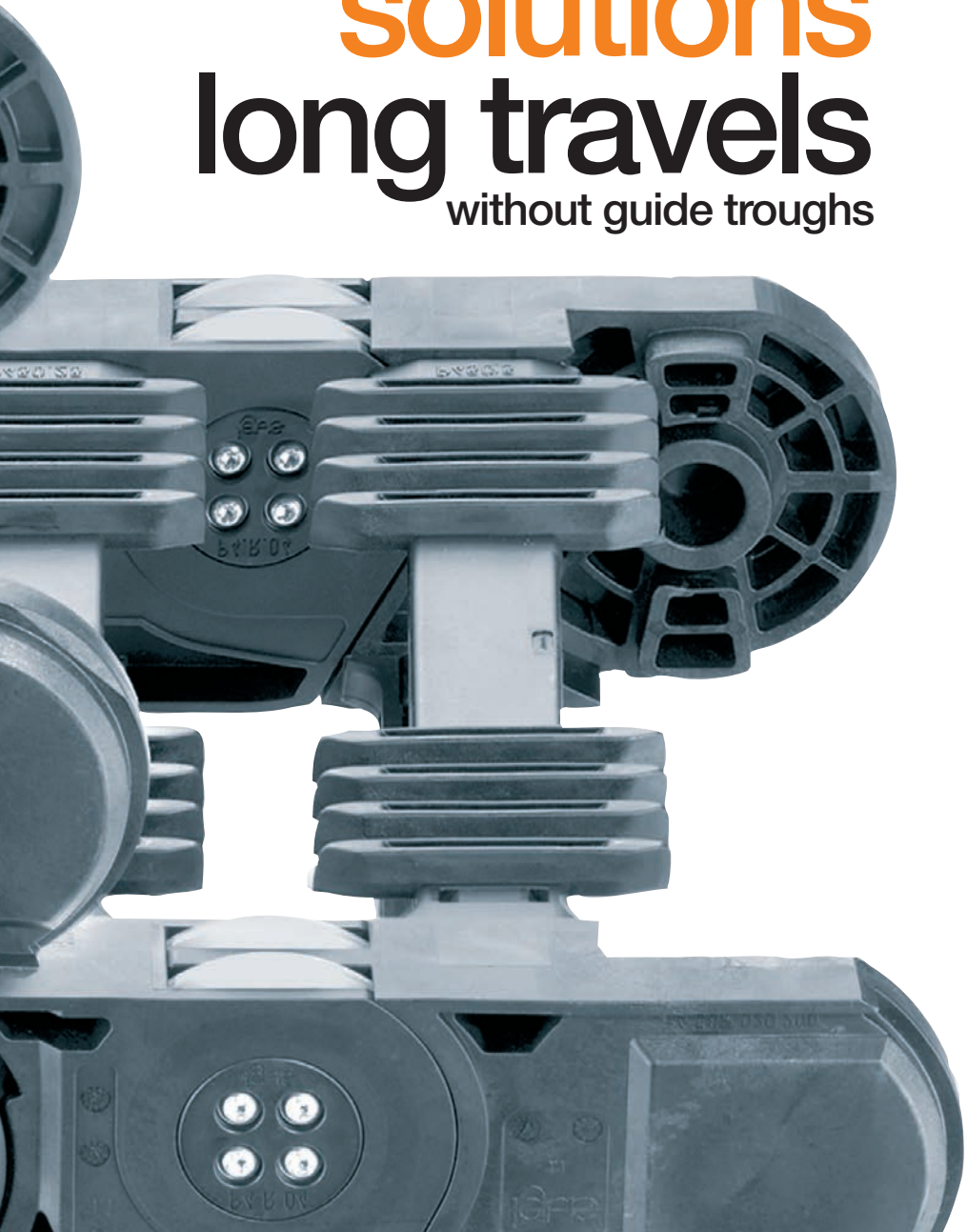

special solutions...long travels



# igus<sup>®</sup> System P4

long travels up to  
800 m, high speeds



# System P4 | rol e-chain® | For very long travels

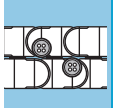

## System P4 - for very long travels up to 800 m

Standard rol e-chain® has been used in over 1000 installations worldwide. Some industries - cranes, for example - have ever-increasing demands for length of travel, fill weight and speed.

**Systems of this type should be designed by our system design engineers. We will be more than willing to submit an offer to you. Please contact us about this.**

- Identical pitch of the chain link with or without roller
- Smooth, low noise operation through identical pitch length for links with and without rollers
- Integrated captive roller in the side part
- Long travels (up to 800 m), high additional loads (up to 30 kg/m)
- For very long travels and high speeds >10 m/s travel speed
- autoglide crossbars provide for a safe guiding in very long travels
- Large modular tool box system with interior separations of the System E4

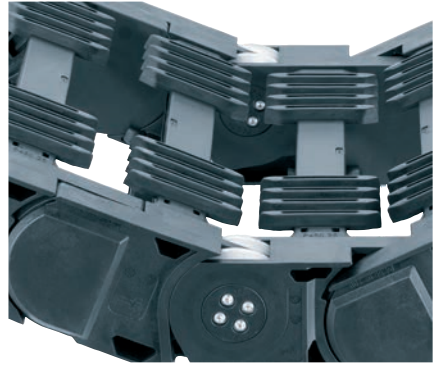

System P4 - Very quiet operation through identical pitch of all chain links. autoglide crossbars offer a safe guidance in very long travels

## Typical industries and applications

- Cranes ● Warehousing ● Equipment manufacturing
- Gantry robots ● Material handling



Find a video online ► [www.igus.de/P4\\_Film](http://www.igus.de/P4_Film)  
Application video ► [www.igus.de/P4cranes](http://www.igus.de/P4cranes)

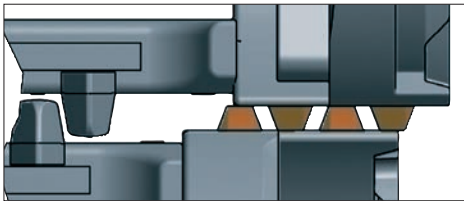

Offset operation of upper and lower run, resulting in continuous roll-through surface



iF produkt design award  
2007 igus® System P4

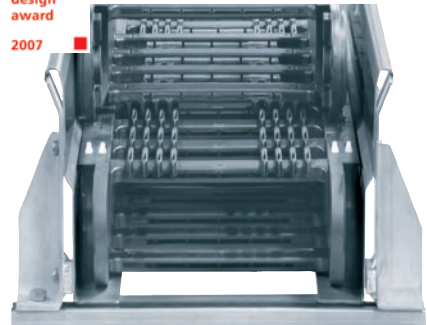

Guide trough system linked with the autoglide crossbars ensures the offset operation of the upper and lower run - safe at high speeds

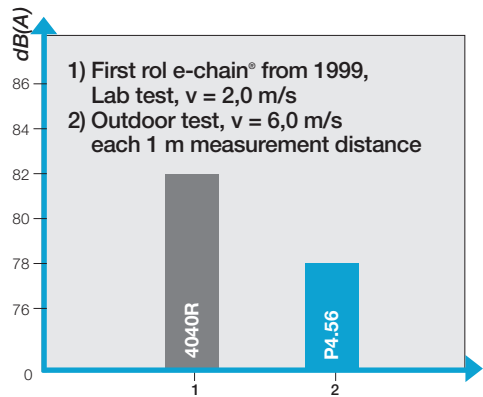
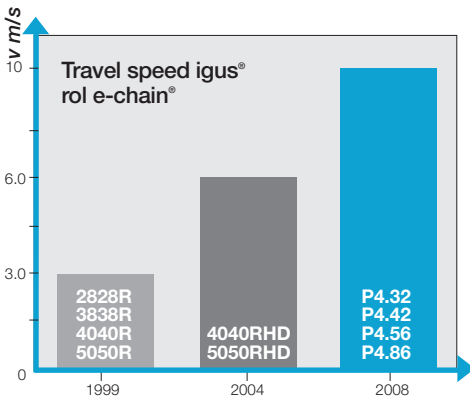

# System P4 | For very high fill weight and speeds

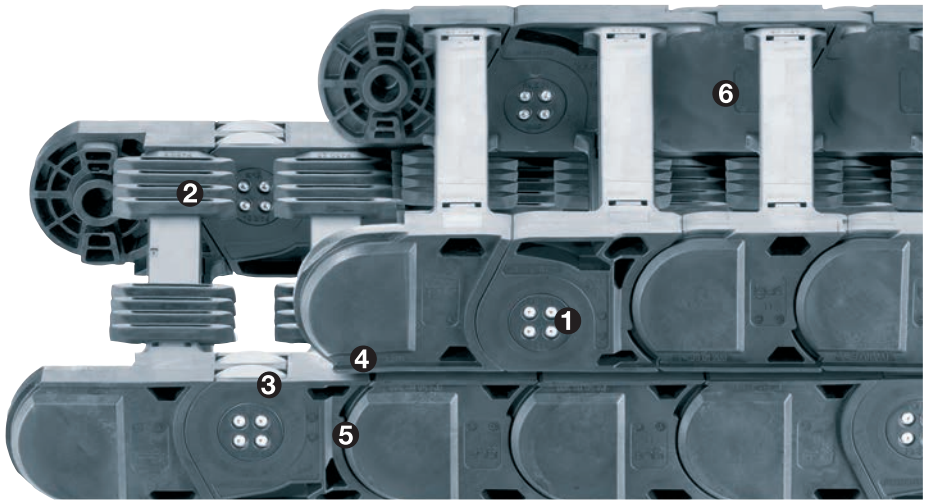

## Safe, low-noise, abrasion-resistant energy supply system on long travels - system P4

With the low-maintenance igus® System P4, a secure energy supply system can be implemented on long travels up to 800 m for cranes or conveyor systems. The upper run and lower run roll staggered on each other. Thus the tribo-optimized plastic rollers don't overrun, but roll on a continuous, wide roll-through surface. The P4 e-chain® is safely guided by the comb-shaped autoglide crossbars and the special trough system. **Ideal for applications with high travel speeds (up to 10 m/s) and large fill weights (up to 30 kg/m)**

- ❶ Low maintenance roller e-chainsystem® from tribooptimized plastic rollers
- ❷ Comb style autoglide cross bars
- ❸ Exceptionally quiet through special roller and link design
- ❹ Offset motion of upper and lower run
- ❺ Same pitch for roller- / chain links
- ❻ 4 different inner heights: 32, 42, 56 and 80 mm available
- ❼ Extension link solution for still higher fill weights with 56 and 80 mm inner height available
- ❽ Robust steel mounting brackets available
- ❾ Special P4 guide trough system available





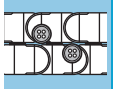

<ul style="list-style-type: none"> <li>● Extension link for heavy fill weights</li> <li>● 2 inner heights available (56, 80 mm)</li> <li>● 50% higher fill weight possible</li> <li>● Maximum rigidity</li> <li>● Divides cross section into compartments (electric/hydraulic)</li> </ul>	<ul style="list-style-type: none"> <li>● Tribo-optimized plastic rollers for all P4 systems</li> <li>● Wear optimized</li> <li>● Long cycle life</li> <li>● Improved rolling</li> <li>● Lower noise and vibration</li> <li>● Same pitch for roller links / chain links</li> </ul>	<ul style="list-style-type: none"> <li>● Guide trough system</li> <li>● Special geometry in combination with autoglide cross bars allows for offset upper and lower run</li> <li>● Strong installation kits for long cycle life</li> <li>● Stainless trough segments resist corrosion and sea water</li> </ul>

# System P4 | Energy efficiency | Save up to ca. 57% energy



## Energy efficient polymer e-chains® and cables reduce consumption by up to 57%

With the right materials and clever design, the energy consumption can be drastically reduced, as now proven by current tests and sample calculations in the e-chain® and cable laboratory at igus®. igus® e-chains® and chainflex® cables reduce the required drive power and extend the application's service life.

<b>Better cables, stronger and rolling e-chains®</b>	<b>System P4</b> <b>-57%</b>	
<b>Rolling instead of gliding</b>	<b>rol e-chain®</b> <b>-37%</b>	
<b>Stronger e-chains®</b>	<b>System E4.1</b> <b>-17%</b>	
<b>Optimized cables</b>	<b>chainflex®</b> <b>-17%</b>	
<b>Gliding application</b>	<b>Standard</b> <b>100%</b>	

### System P4



### chainflex®



**=**

**-57%**

**less energy consumption**

Sample calculations online ► [www.igus.eu/eu/energyefficiency](http://www.igus.eu/eu/energyefficiency)



Successful application with P4.56 on a RMG crane. 130 m travel length at 150 m/min speed. Harnessed with igus® chainflex® motor-, control- and fiber optic cables

# System P4 | Series P4.32 | Dimensions and Technical Data

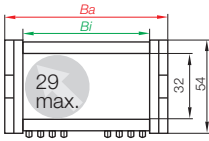
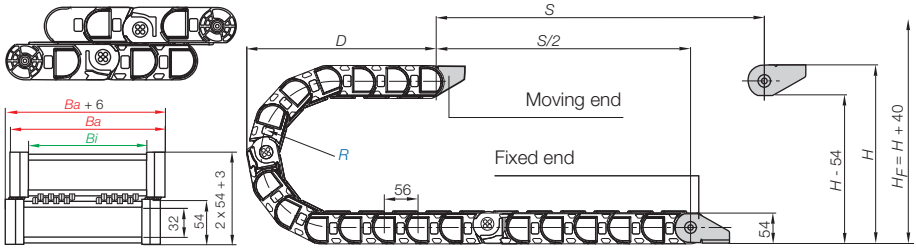

## Series P4.32 - rol e-chain® with comb style autoglide cross bars

Part No.	Bi	Ba	R	Bending Radii	Weight [kg/m]
P4.32.10.	.0	100 132	075* 100 125	150 200 250 300	≈ 2,71
P4.32.15.	.0	150 182	075* 100 125	150 200 250 300	≈ 3,04
P4.32.20.	.0	200 232	075* 100 125	150 200 250 300	≈ 3,34

075\* | 100 | 125 | 300 Radius available upon request, please consult igus® for delivery time

Supplement Part No. with required radius. Example: P4.32.15. 150 .0

### Part No. structure

P4.32.20. 150. 0.



Color  
Radius  
Width  
Series

Pitch = 56 mm/link Links/mm = 18 (1008 mm) Chain length =  $\frac{S}{2} + K$

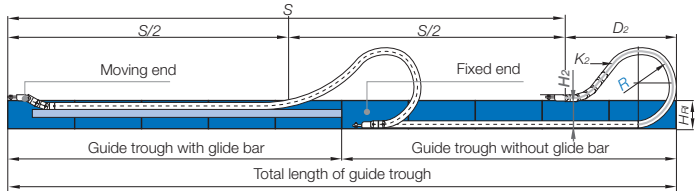

R	075*	100*	125*	150	200	250	300*
H	209	259	309	359	459	559	659
D	160	185	210	235	285	335	385
K	350	430	505	585	745	900	1055
H <sub>2</sub>	125	125	125	125	125	125	125
D <sub>2</sub>	425	500	635	760	1015	1400	1625
K <sub>2</sub>	728	840	1064	1232	1624	2072	2464

\*Radius available upon request, please consult igus® for delivery time!

## Technical Data



Details of material properties

► page 126

Long travels	up to max. 600 m
Speed max. rolling / acceleration max. rolling	max. 10 [m/s] / max. 50 [m/s <sup>2</sup> ]
Fill weight	max. 7,0 [kg/m]
Material - permitted temperature °C, igumid G / GLW	-40° up to +100° C
Flammability class, igumid G / GLW	VDE 0304 IIC UL94-HB

## Additional Features

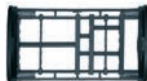

Interior separation  
available - Series E4.32

► from page 383



Robust steel mounting  
brackets available

► upon request



Special P4 guide  
trough system available

► upon request

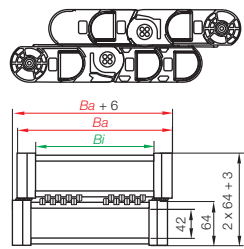
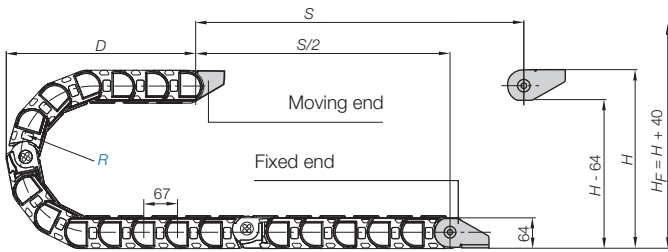
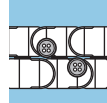

## Series P4.42 - roller chain® with comb style autoglide cross bars

Part No.	Bi	Ba	R	Bending Radii							Weight [kg/m]
P4.42.10.□.0	100	154	100	125	150	200	250	300	350	= 3,95	
P4.42.15.□.0	150	204	100	125	150	200	250	300	350	= 4,22	
P4.42.20.□.0	200	254	100	125	150	200	250	300	350	= 4,47	

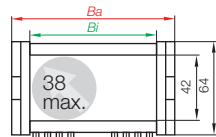

Supplement Part No. with required radius. Example: P4.42.15.□.0

### Part No. structure

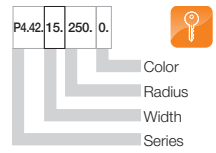

Pitch = 67 mm/link    Links/m = 15 (1005 mm)    Chain length =  $S/2 + K$

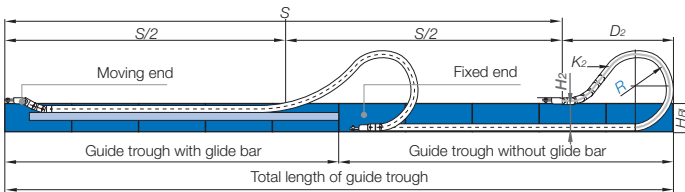

R	100	125	150*	200	250	300	350
H	268	318	368	468	568	668	768
D	201	226	251	301	351	401	451
K	450	530	610	765	920	1080	1235
H <sub>2</sub>	140	140	140	140	140	140	140
D <sub>2</sub>	520	785	940	1280	1620	1960	2265
K <sub>2</sub>	930	1206	1407	1876	2345	2814	3216

## Technical Data



Details of material properties

► page 126

Long travels	up to max. 800 m
Speed max. rolling / acceleration max. rolling	max. 10 [m/s] / max. 50 [m/s <sup>2</sup> ]
Fill weight	max. 15,0 [kg/m]
Material - permitted temperature °C, igumid G / GLW	-40° up to +100° C
Flammability class, igumid G / GLW	VDE 0304 IIC UL94-HB

## Additional Features

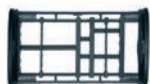

Interior separation available - Series E4.42

► from page 389



Robust steel mounting brackets available

► upon request



Special P4 guide trough system available

► upon request

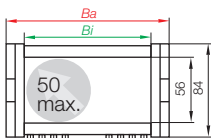
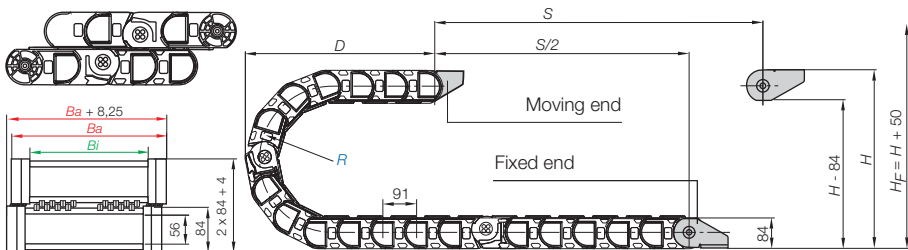

### Part No. structure

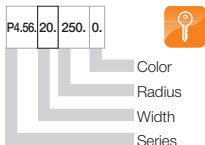

### Series P4.56 - rol e-chain® with comb style autoglide cross bars

Part No.	Bi	Ba	R	Bending Radii	Weight [kg/m]
P4.56.18.	0	180	250	150   200   250   300   350   400   450   500	≈ 6,72
P4.56.20.	0	200	270	150   200   250   300   350   400   450   500	≈ 7,03
P4.56.25.	0	250	320	150   200   250   300   350   400   450   500	≈ 7,39
P4.56.30.	0	300	370	150   200   250   300   350   400   450   500	≈ 7,79
P4.56.35.	0	350	420	150   200   250   300   350   400   450   500	≈ 8,19
P4.56.40.	0	400	470	150   200   250   300   350   400   450   500	≈ 8,49

150 | 400 | 450 | 500 Radius available upon request, please consult igus® for delivery time

Supplement Part No. with required radius. Example: P4.56.20.250.0

Pitch = 91 mm/link Links/m = 11 (1001 mm) Chain length =  $S/2 + K$

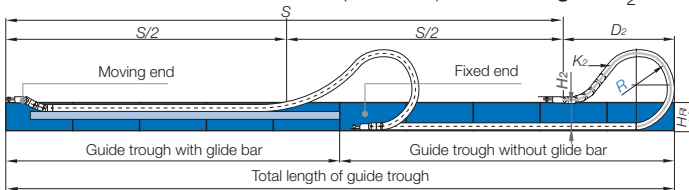

R	150*	200	250	300	350	400*	450*	500*
H	390	490	590	690	790	890	990	1090
D	286	336	386	436	486	536	586	636
K	655	815	970	1125	1285	1440	1600	1755
H <sub>2</sub>	**	180	180	180	180	180	**	**
D <sub>2</sub>	**	1140	1470	1700	1950	2255	**	**
K <sub>2</sub>	**	1820	2275	2639	3003	3458	**	**

\*Radius available upon request, please consult igus® for delivery time! \*\* values upon request

### Technical Data



Details of material properties

► page 126

Long travels	up to max. 800 m
Speed max. rolling / acceleration max. rolling	max. 10 [m/s] / max. 50 [m/s <sup>2</sup> ]
Fill weight	max. 15 [kg/m]
Material - permitted temperature °C, igumid G / GLW	-40° up to +100° C
Flammability class, igumid G / GLW	VDE 0304 IIC UL94-HB

### Additional Features

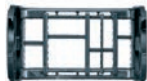

Interior separation available - Series E4.56

► from page 395



Extension link for heavy fill weights available

► upon request



Robust steel mounting brackets available

► upon request



Special P4 guide trough system available

► upon request

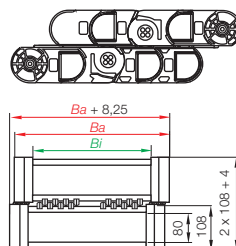
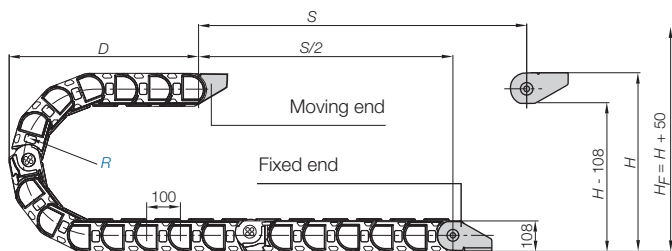
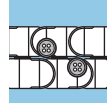

## Series P4.80 - roller chain® with comb style autoglide cross bars

Part No.	Bi	Ba	R	Bending Radii								Weight [kg/m]
P4.80.18, .0	180	256	150	200	250	300	350	400	450	500	≈ 8,85	
P4.80.20, .0	200	276	150	200	250	300	350	400	450	500	≈ 9,13	
P4.80.25, .0	250	326	150	200	250	300	350	400	450	500	≈ 9,46	
P4.80.30, .0	300	376	150	200	250	300	350	400	450	500	≈ 9,83	
P4.80.35, .0	350	426	150	200	250	300	350	400	450	500	≈ 10,19	
P4.80.40, .0	400	476	150	200	250	300	350	400	450	500	≈ 10,46	

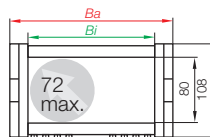

### Part No. structure

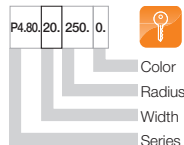

[150] [200] [400] [450] Radius available upon request, please consult igus® for delivery time

Supplement Part No. with required radius. Example: P4.80.20.[250].0

Pitch = 100 mm/link    Links/m = 10 (1000 mm)    Chain length =  $S/2 + K$

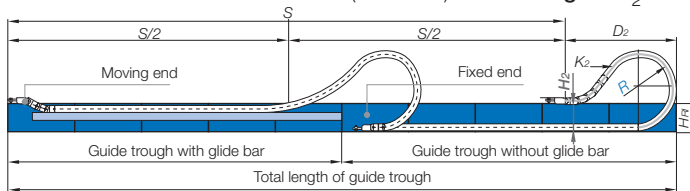

R	150*	200*	250	300	350	400*	450*	500
H	420	520	620	720	820	920	1020	1120
D	310	360	410	460	510	560	610	660
K	675	830	990	1145	1300	1460	1615	1775
H <sub>2</sub>	180	180	180	180	180	180	180	180
D <sub>2</sub>	955	1310	1610	1974	2060	2625	2910	3275
K <sub>2</sub>	900	1400	1800	2300	2700	3200	36000	4100

\*Radius available upon request, please consult igus® for delivery time!

Long travels	up to max. 800 m
Speed max. rolling / acceleration max. rolling	max. 10 [m/s] / max. 50 [m/s <sup>2</sup> ]
Fill weight	max. 15 [kg/m]
Material - permitted temperature °C, igumid G / GLW	-40° up to +100° C
Flammability class, igumid G / GLW	VDE 0304 IIC UL94-HB

## Technical Data



Details of material properties

► page 126



Interior separation available - Series E4.80

► from page 401



Extension link for heavy fill weights available

► upon request



Robust steel mounting brackets available

► upon request



Special P4 guide trough system available

► upon request

## Additional Features





**rol e-chain**®

long travels up to 600 m

# rol e-chain® | Special solutions for long travels

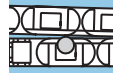

## rol e-chain® - Rolling instead of gliding

e-chains® are being used in ever longer travels. This has driven the development of the rol e-chain®. Additionally, movement speeds are increasing in combination with larger and larger fill weights (up to 50 kg/m). **Please contact us if you have decided for this product. We'll assist you in the project planning!**

- Major reduction in drive power to less than 25 % for moving the e-chain®
- Travels up to 600 m possible
- Speeds up to 6 m/s possible
- Various roller types for optimum application adaption
- Can be used even in dirty environments
- Available as ready-to-fit, made-to-specifications system
- System guarantee for made-to-specifications systems



Cutting the operating noise by approx. 6dB(A) through improved geometry of e-chain® link and roller. Stainless steel roller bearings are the igus® standard

## Typical industries and applications

The igus® rol e-chain® is designed for applications where long travels at high speeds have to be realized. This is, for instance, frequently the case with moving camera systems or material handling systems, even in the case of slower applications in the crane sector or travelling plants the low friction values of the system allow cost-savings, since the drives can be considerably smaller.

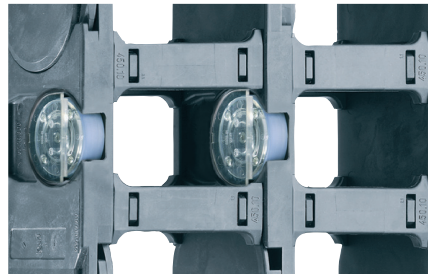

Roller extension link for higher additional weights and widths up to 2 m and more



Cross travel of 441.3 m, implemented with igus® rol e-chain® Series 5050R

# rol e-chain® | Delivery program

## Delivery program rol e-chain®

Interior heights of 32, 42, 56 and 80 mm and widths of 50 mm up to several meters are possible and are available from stock. All interior separation options and mounting bracket variants of the igus® system E4 are available. The standard guide troughs of the relevant e-chains® from stock can be used rol e-chains® can basically be opened along both radii. The rol e-chain® is available as a made-to-spec e-chainsystem®. The rol e-chain® standard are stainless-steel ball-bearings. It is fitted with chainflex® cables and made-to-spec

connectors and fittings in accordance with your requirements by igus® specialists and packaged in installation-friendly manner. Depending on the length of travel, the rol e-chain® can be delivered on a drum. If cables from the chainflex® range are to be used, we will be more than willing to assume warranty for the full system. **Systems of this type should be designed by our system design engineers. We will be more than willing to submit an offer to you. Please contact us about this.**

## Delivery program

Series	Inner height <i>hi</i> [mm]	Inner width <i>Bi</i> [mm]	Outer width <i>Ba</i> [mm]	Outer height <i>ha</i> [mm]	Bending radius <i>R</i> [mm]
<b>rol e-chain® - with crossbars every 2<sup>nd</sup> link</b>					
2828R	32	50 - 400	73 - 3000**	54	125 - 300
3838R	42	50 - 400	77 - 3000**	64	150 - 350
4040R	56	50 - 600	86 - 3000**	84	200 - 500
4040 RHD*	56	50 - 600	140 - 3000**	84	200 - 500
5050R	80	50 - 600	100 - 3000**	108	250 - 500
5050 RHD*	80	50 - 660	160 - 3000**	108	200 - 500
<b>rol e-chain® - e-tube, fully enclosed</b>					
R7728R	32	50 - 300	73 - 3000**	54	250 - 300
R7838R	42	50 - 300	77 - 3000**	64	200 - 350
R8840R	56	75 - 462	111 - 3000**	84	300 - 500
R9850R	80	75 - 462	125 - 3000**	108	300 - 1000

\*\*The max. outer width of 3000 mm can only be reached using extension links.

- 4040 RHD\* / 5050 RHD\* = extra stable versions of series 4040R and 5050R
- 4040R/5050R = for e-chain® widths up to 3000 mm with extension link/roller extension link
- Series 2828R, 3838R, 4040R, 5050R are also available as autoglide versions (no guiding trough required)

## Proven advantage: Reduce push-pull forces over 75% with igus® rol e-chain®

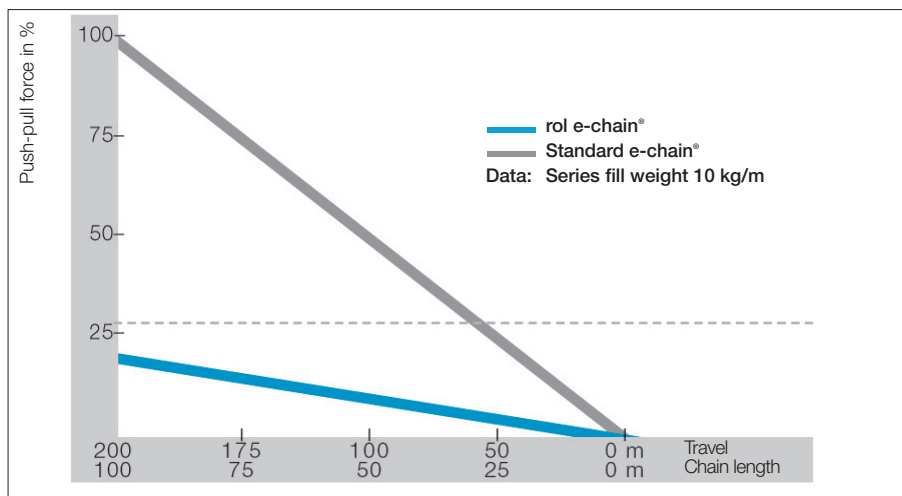

Comparison of the power requirement between rol e-chain® and a standard e-chain®

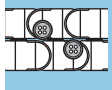

rol e-chain® Serie 5050R in a steel plant in india with highly corrosive atmosphere -  $s = 22\text{ m}$ ,  $v = 1\text{ m/s}$ ,  $a = 1\text{ m/s}^2$



Power plant application with igus® rol e-chain® 4040R - Travel 46 m, Speed 1.5 m/s, Fill weight 5.3 kg/m



Assembled system in a ship unloading crane with 5050RHD - Travel 106 m, Speed 4 m/s, Fill weight 25 kg/m



Series 4040R on a coal unloading system - Travel 190 m, Speed 0.5 m/s, Fill weight 8.05 kg/m



Series 4040R in steel works environment - Travel 10.5 m, Speed 60 m/min, Fill weight 6.084 kg/m



igus® e-chains® 5050RHD rol e-chain® in an igus® super-alu-trough = 75% less driving power



**autoglide**

self-guiding e-chainsystem®



## autoglide - self-guiding e-chainsystem® - no guide troughs required

Long travels are always demanding for an e-chainsystem®. For much of the travel, the e-chain must run on the lower run or on the glide bars. In addition the e-chainsystem® needs guides, in order to prevent a sideward movement. In most cases this is ensured through a guide trough. However, there are also applications where a guide trough is not desired for space reasons, whether this is due to optical considerations or spatial conditions. In order to cater for this possibility, igus® developed the autoglide system in 1995. autoglide is a self-aligning e-chain®, which can dispense with guide troughs for up to 50 m travel. You save acquisition and installation costs and can keep pathways in your warehouse free for forklifts or industrial trucks.

- Travels up to 50 m
- Travel speeds up to 1,5 m/s
- e-chain® links of a piece, no additional parts required
- Very quick installation times for long travels
- Guide troughs not required!
- Small installation width, silent operation
- Functional guarantee for the entire system with chainflex® cables

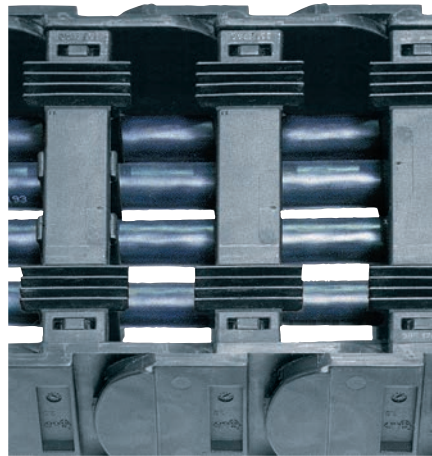

In principle every igus® e-chain® can be fitted out for the autoglide system. However, we recommend its use with e-chain® whose interior height is less than 35 mm, and you should also consult us, since there are restrictions regarding the bending radii to be used

## There are 4 options of the igus® autoglide system:

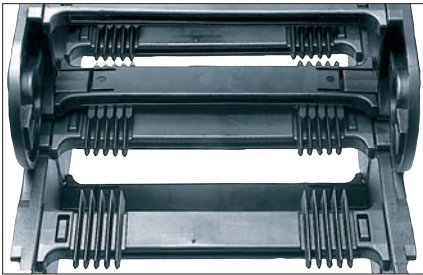

Option 1 - is available for almost all System E4 Series - here the crossbars in the interior radius of the e-chain® are fitted with molded-on autoglide grooves

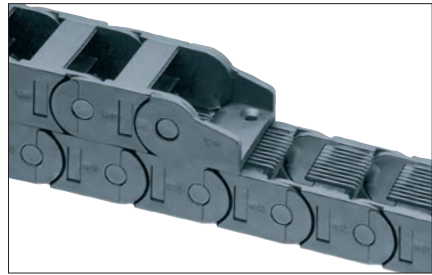

Option 2 - for Series 200 e-chains®: Injection-molded autoglide grooves in the inner radius. One-piece e-chain® with firmly molded horizontal interior separation

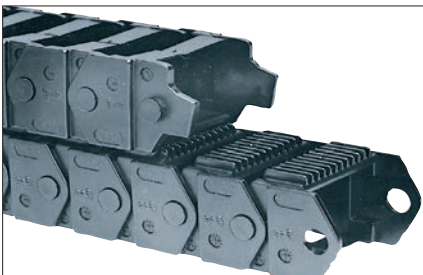

Option 3 - for igus® easy chain® e-chain® combination of the easily fillable easy chain® and injection-molded autoglide grooves in the inner radius

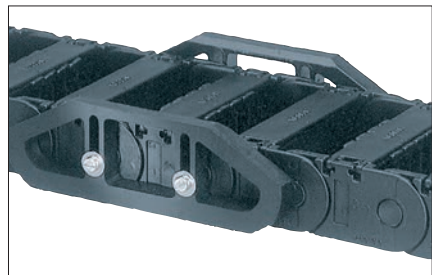

Option 4 - for Series E2/000 e-chain® - Special plastic autoglide grooves side-mounted on the e-chain® hold the e-chain® "in the track"



❶ autoglide e-chain® with assembled glide wing

Part No. structure

E4.56.21.250.0.AG.OF



Complete unit



❷ autoglide e-chain® with separate glide wing (unassembled)

Part No. structure

E4.56.21.250.0.AG



Complete unit



❸ autoglide glide wing and floor guide as single parts. A glide wing and floor guides every two meter completely replace a guide trough



Industrial trucks can run over the floor guides

## Option 1: autoglide for System® E4.1 up to 56 mm interior height

Large gliding surfaces and good sliding behavior - Of one piece, no additional parts required. Option 1 is available for the larger e-chains® of System E4.1 - here the crossbars in the interior radius of the e-chain® are fitted with molded-on autoglide grooves. With autoglide the length of the e-chain® can be the entire travel plus add-on for the bending radius.

- ❶ autoglide e-chain® with assembled glide wing
- ❷ autoglide e-chain® with separate glide wing (unassembled)
- ❸ Glide wing and floor guide as single parts

## System E4.1 autoglide (autoglide crossbars along the inner radius)

Part No.		Bi	Ba	R Bending radius													
E4.32.112.	<input type="checkbox"/> .0.AG	112	136	100	125	150	175	200	220	250	300						
E4.32.12.	<input type="checkbox"/> .0.AG	125	148	100	125	150	175	200	220	250	300						
E4.32.15.	<input type="checkbox"/> .0.AG	150	173	100	125	150	175	200	220	250	300						
E4.32.17.	<input type="checkbox"/> .0.AG	168	191	100	125	150	175	200	220	250	300						
E4.32.20.	<input type="checkbox"/> .0.AG	200	223	100	125	150	175	200	220	250	300						
E4.32.262.	<input type="checkbox"/> .0.AG	262	286	100	125	150	175	200	220	250	300						
E4.42.112.	<input type="checkbox"/> .0.AG	112	139	125	150	170	200	115	250	300							
E4.42.12.	<input type="checkbox"/> .0.AG	125	151	125	150	170	200	115	250	300							
E4.42.15.	<input type="checkbox"/> .0.AG	150	176	125	150	170	200	115	250	300							
E4.42.17.	<input type="checkbox"/> .0.AG	168	194	125	150	170	200	115	250	300							
E4.42.20.	<input type="checkbox"/> .0.AG	200	226	125	150	170	200	115	250	300							
E4.42.262.	<input type="checkbox"/> .0.AG	262	289	125	150	170	200	115	250	300							
E4.56.15.	<input type="checkbox"/> .0.AG	150	184	150	175	200	240	250	300	350	400	500					
E4.56.21.	<input type="checkbox"/> .0.AG	212	247	150	175	200	240	250	300	350	400	500					
E4.56.25.	<input type="checkbox"/> .0.AG	250	284	150	175	200	240	250	300	350	400	500					

autoglide also available for Series 280, 2828, 380, 3838, 400, 4040 and 5050

Supplement Part No. with required radius. Example: E4.56.21.[250].0.AG

Further widths on request - Delivery time: approx. 6-8 weeks after receipt of order!

## Long travel without guide trough - Glide wing and floor guide

Simple guide elements for quick installation on the subsurface are available for the autoglide system version 1. The traversable excentric floor guides are fastened every 2 m on the subsurface. The glide wing fastened on the moving end feeds the e-chain® and holds this securely in the track. The autoglide crossbars safely guide the e-chain® and replace the guide trough. ● Save purchase and installation costs with this system ● Traversable over floor guide for travel distances over 10 m. **Note: Only two glide wings AG.XXX.OF are required for the safe feeding of the e-chain®.** The mounting of the glide wing is done on the outer link of the upper run, which is laid down first on the lower run.



## Delivery program

Floor guide, set (single part, left and right)	For Series
AG.380.BF	universal
Glide wing (single part, without screws)	For Series
AG.280.OF	E4.32 / 280 / 2828
AG.380.OF	E4.42 / 380 / 3838
AG.400.OF	E4.56 / 400 / 4040

# autoglide | Delivery program | Option 1



## Roller autoglide RAG

Special feature: Series 4040 and 5050 also available as rolling autoglide. For long travel and 75% less drive power (gliding application). We request for a consultation in case you have decided on this product.

## System E4 Roller autoglide options

Part No.	Bi	Ba	R	Bending radius										
4040.28.	.0.RAG	287	324	135	150	175	200	240	250	300	350	400	500	
4040.36.	.0.RAG	362	399	135	150	175	200	240	250	300	350	400	500	
5050.28.	.0.RAG	287	338	150	200	250	300	350	400	500	550	600	650	1000
5050.36.	.0.RAG	362	413	150	200	250	300	350	400	500	550	600	650	1000

Supplement Part No. with required radius. Example: 4040.28.150.0.RAG



Comprehensive information for each E4 Series can be found at the relevant catalog page

Series	Inner-height $h_i$	Outer-height $h_a$
E4.32	32	54
E4.42	42	64

Series	Inner-height $h_i$	Outer-height $h_a$
E4.56	56	84
E4.80*	80	108

\*Also available as autoglide e-chain\*

Part No. structure

4040.28.250.0.RAG



# autoglide | Delivery program | Option 2

## Option 2: Series 200 - Molded autoglide grooves in the inner radius

One-piece e-chain® with molded autoglide grooves in the inner radius.

Available in one width, with molded horizontal interior separation.

- autoglide e-chain® links are moulded and no additional parts are necessary
- Guide troughs not required!
- Narrow construction width, quiet running
- Function guarantee on the whole system with chainflex® cables



## Series AG.200 - Combination: autoglide and E2 medium (Series 200)

Part No.	Bi	Ba	R	Bending radius									
AG.200.05.	100	0.A2	57	73,2	055	075	100	125	150	175	200	225	250

055 075 125 150 175 200 225 250 Radius available upon request, please consult igus® for delivery time

Supplement Part No. with required radius. Example: AG.200.05.100.0.A2

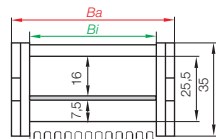

Pitch = 46 mm Links/m = 22 Chain length = S + K

R	055*	075*	100	125*	150*	175*	200*	225*	250*
$H_2$	110	150	100	100	100	100	100	100	100
$D_2^{+25}$	142	162	380	440	590	755	950	1040	1130
$K_2$	265	330	644	736	1012	1242	1472	1610	1794

The required clearance height is:  $H_f = H + 25$  mm, must be noted in all types of applications

\*Radius available upon request, please consult igus® for delivery time

Part No. structure

AG.200.05.100.0.







## Option 3: As EA16 and EA25

The version 3 is a combination of autoglide version 2 and easy chain®. The grooves similar to tie-wrap plates are molded directly on the e-chain® link and available at present in two sizes.

- autoglide e-chain® links of a piece, no additional parts required
- Very quick installation times for long travels
- Guide troughs not required!
- easy chain® system: Cables and hoses can be inserted without opening the e-chain®
- Small installation width, silent operation
- Functional guarantee for the entire system with chainflex® cables

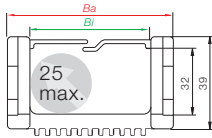

## Series EA16 - Combination of autoglide and easy chain®

Part No.	Bi	Ba	R Bending radius
EA16.4.□.0	48	60	065 075 100

Supplement Part No. with required radius. Example: EA16.4.060.0

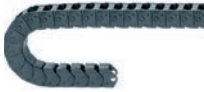

## Mounting bracket

with strain relief (full set) Part No. EA16.4.12PZ

Part No. structure

EA16. 4. 060. 0.



Color  
Radius  
Width  
Easy autoglide

Pitch = 30,5 mm      Links/m = 33      Chain length = S + K

R	065	075	100	*
H	159	189	239	
D	125	140	165	
K	250	300	380	

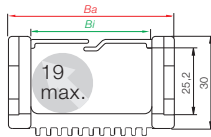

## Series EA25 - Combination of autoglide and easy chain®

Part No.	Bi	Ba	R Bending radius
EA25.050.□.0	50	60	075 100

Supplement Part No. with required radius. Example: EA25.050.075.0



## Mounting bracket

with strain relief (full set) Part No. EA25.050.12PZ

Part No. structure

EA25. 050. 075. 0.



Color  
Radius  
Width  
Easy autoglide

Pitch = 25 mm      Links/m = 40      Chain length = S + K

R	075	100
H	180	230
D	135	160
K	290	375



## Option 4: For e-chainsystem® E2 up to 35 mm inner height

In this version, special plastic autoglide grooves are side-mounted on the e-chain® link every 1,000 to 2,000 mm. The function of these gliding shoes resembles the leeboards used on sail boats. Some of these leeboards are conceived in such a way that in contact they pivot upward and enable the continuation of the travel. Similarly the autoglide grooves in autoglide go up and down, each according to its position as lower run or upper run of the e-chain®. They provide for the precise lateral guidance and a smooth gliding of the e-chain®

- The autoglide grooves are mounted on every 24<sup>th</sup> link starting from the moving end
- Series 2400/2450/2480/2500 allow up to 15 m length without floor guides

**Please note:** the outer width incl. autoglide grooves is:  $B_i + 47$  mm!

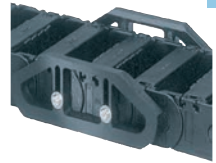

### Series 2400/2450/2480/2500 - autoglide and System E2/000

Part No.		$B_i$	$B_a$	$R$	Bending radius								
2400/2450/2480/2500.02.	<input type="checkbox"/> .0.AG	25	41	055*	075*	100	125	150	175	200	225	250	
2400/2450/2480/2500.03.	<input type="checkbox"/> .0.AG	38	54	055*	075*	100	125	150	175	200	225	250	
2400/2450/2480/2500.05.	<input type="checkbox"/> .0.AG	57	73	055*	075*	100	125	150	175	200	225	250	
2400/2450/2480/2500.07.	<input type="checkbox"/> .0.AG	77	93	055*	075*	100	125	150	175	200	225	250	
2400/2450/2480/2500.09.	<input type="checkbox"/> .0.AG	89	105	055*	075*	100	125	150	175	200	225	250	
2400/2450/2480/2500.10.	<input type="checkbox"/> .0.AG	103	119	055*	075*	100	125	150	175	200	225	250	
2400/2450/2480/2500.12.	<input type="checkbox"/> .0.AG	125	141	055*	075*	100	125	150	175	200	225	250	

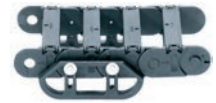
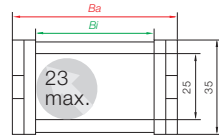

Supplement Part No. with required radius. Example: 2400.10..0.AG

**Please note:** For using this series for long travels (gliding), please consult with igus® first.

For long travels, igus® specifies e-chains® that snap open on the outer radius.

Installation point = final travel

Chain length =  $S + K_2$

$R$	055*	075	100	125	150	175	200	225	250
$H_2$	110	150	100	100	100	100	100	100	100
$D_2^{+25}$	142	162	380	440	590	755	950	1040	1130
$K_2$	265	330	644	736	1012	1242	1472	1610	1794

From  $R$  100: with lowered mounting height!

\*for Series 2450/2480 upon request.

Part No. structure

2400.	10.	<input type="text" value="100"/> .	0.	AG
-------	-----	------------------------------------	----	----

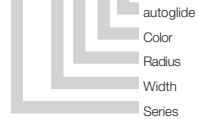

### Series 2600/2650/2680/2700 - autoglide and System E2/000

Part No.		$B_i$	$B_a$	$R$	Bending radius								
2600/2650/2680/2700.05.	<input type="checkbox"/> .0.AG	50	66	063*	075*	100	125	150	175	200	250		
2600/2650/2680/2700.06.	<input type="checkbox"/> .0.AG	65	81	063*	075*	100	125	150	175	200	250		
2600/2650/2680/2700.07.	<input type="checkbox"/> .0.AG	75	91	063*	075*	100	125	150	175	200	250		
2600/2650/2680/2700.09.	<input type="checkbox"/> .0.AG	90	106	063*	075*	100	125	150	175	200	250		
2600/2650/2680/2700.10.	<input type="checkbox"/> .0.AG	100	116	063*	075*	100	125	150	175	200	250		
2600/2650/2680/2700.12.	<input type="checkbox"/> .0.AG	125	141	063*	075*	100	125	150	175	200	250		
2600/2650/2680/2700.15.	<input type="checkbox"/> .0.AG	150	166	063*	075*	100	125	150	175	200	250		
2600/2650/2680/2700.17.	<input type="checkbox"/> .0.AG	175	194	063*	075*	100	125	150	175	200	250		

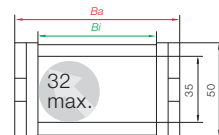

Supplement Part No. with required radius. Example: 2600.15..0.AG

**Please note:** For using this series for long travels (gliding), please consult with igus® first.

For long travels, igus® specifies e-chains® that snap open on the outer radius.

Installation point = final travel

Chain length =  $S + K_2$

$R$	063*	075*	100	125	150	175	200	250
$H_2$	130	150	166	166	166	166	166	166
$D_2^{+25}$	140	150	350	475	500	655	770	950
$K_2$	335	375	616	784	896	1120	1288	1624

From  $R$  100: with lowered mounting height!

\*for Series 2650/2680 upon request

Part No. structure

2600.	15.	<input type="text" value="100"/> .	0.	AG
-------	-----	------------------------------------	----	----

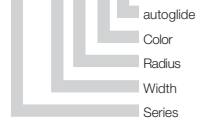



# guidelok horizontal

Upper run guide for long travels

# guidelok horizontal | Upper run guide , self-supporting



## Upper run guide for long travels, self-supporting in chip areas

Especially for long travels on machine tools, when the e-chain® has to be gliding, metallic chips are a problem. guidelok horizontal is a cost-effective solution

- Travels, unsupported up to 50 m possible
- Chips cannot get stuck between upper and lower run
- Modular system with few parts (also possible without sideways trough)
- Enormous increase of "self supporting" length of e-chains®
- Lower push-/pull forces (smaller-chains®, self supporting and rollers = energy efficient)
- Systeme Lower cost than most steel chains or sophisticated gliding systems
- Open guide trough design, chips can fall through

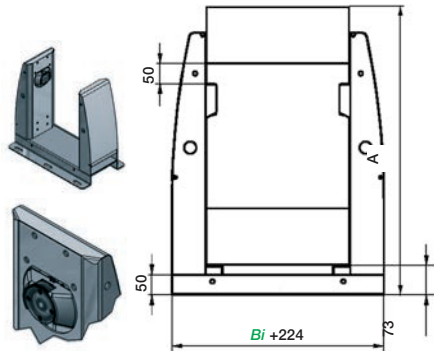

## Typical industries and applications

- Machine tools
- Applications in the chip area
- Wherever a gliding application is not recommended

**Design-principle - horizontal guidelok guides the e-chain® on special spring loaded roller supports, that are pushed back by the e-chains® radius, clearing its path**



The e-chain® is guided in the trough channel, pushing back the spring loaded roller support with its radius...



...which snaps back out again after the e-chain® radius has passed...



...the upper run then gets to lay on the roller support.

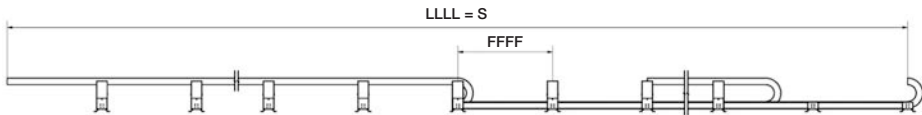

Principle sketch - guidelok horizontal

## Delivery program

For Series	Bi	R Bending radius	Dim. A	Part No. horizontal trough with guidelok	
E4.56/R4.56	50 - 600	150, 175, 200, 250, 300		907.645.Bi.R.LLLL/FFFF	LLLL = Total length
E4.80/R4.80	50 - 600	150, 175, 200, 250, 300		907.645.Bi.R.LLLL/FFFF	FFFF = Field length
E4.112	200 - 600	150, 175, 200, 250, 300		907.645.Bi.R.LLLL/FFFF	
E4.56/R4.56	50 - 600	350, 400, 450, 500		907.837.Bi.R.LLLL/FFFF	
E4.80/R4.80	50 - 600	350, 400, 450, 500		907.837.Bi.R.LLLL/FFFF	
E4.112	200 - 600	350, 400, 450, 500		907.837.Bi.R.LLLL/FFFF	

For many more types (widths/radii) possible, due to the modular design - please contact us



# guidelok slimline F

Safe vertical guidance



# guidelok slimline F | Up to 7 m/s and 10 m/s<sup>2</sup>

## guidelok slimline F: Safe vertical guidance for e-chains® in high-speed rack feeders

In highly dynamic rack feeder a speed for the horizontal movement exceeding in 6 m/s is not uncommon. The advanced igus® guidelok slimline F guides e-chains® even at the fastest speed.

- Up to 7 m/s and 10 m/s<sup>2</sup>
- Up to 80% less trough required
- Saving costs and weight
- For hanging systems up to 50 m
- No swinging of the e-chain®, high reliability through lever mechanism and guiding rails
- Faster and easier installation
- Reduced noise
- Easy access for servicing
- Energy and data and all kinds of media are safely guided without interrupt in one single system

### Typical industries and applications

- Storage and retrieval units ● Lifts ● Elevators
- Construction and crane lifts ● Hoists



**Note:** Systems of this type should be designed by our system design engineers. We will be more than willing to submit an offer to you. Please contact us about this.



Find a video online

► [www.igus.eu/eu/glsi-f.movie](http://www.igus.eu/eu/glsi-f.movie)

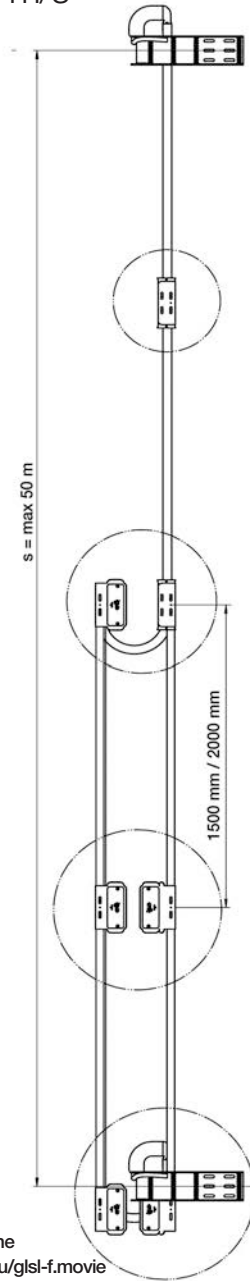

### Delivery program

For Series	Bi	R Bending radii	Part. No. vertical trough with guidelok LLLL = total length/height	max speed vertical	max speed horizontal
255	103	150	GLSL.F.255. 10.150.LLLL/FFFF	4 [m/s]	7 [m/s]
2700	100	150	GLSL.F.2700.10.150.LLLL/FFFF	4 [m/s]	7 [m/s]

More sizes/dimension upon request!



**igus<sup>®</sup>**  
**lbt flizz<sup>®</sup>**  
enclosed plastic troughs



## lbt flizz® - High speeds and accelerations

- Travels up to 120 m, speeds up to 8 m/s
- Applicable for moving and stationary control, ideal for all bus systems
- Good for applications needing low weight and good corrosion resistance
- Quiet and maintenance free operation
- At -10°C up to +60°C continuous temperature
- Accelerations over 10 m/s<sup>2</sup>
- Energy supply for all media, not only for electrical
- Also suitable for outdoor use (with reduced load data)



## lbt flizz® System

The complete system comprises the igus® e-chain®, the lbt flizz® guide trough and the igus® chainflex® cables which can be fully made-to-spec on request. The lbt flizz® guide trough consists of a modular system, based on extruded guide profiles and a supporting frame with continuous tubes for stabilization. All components are of corrosion-protection, made either extruded or powder-coated high-quality plastic. The materials used are resistant to weathering and resistant to most chemicals, oils, greases, coolants and solvents. The optionally fully enclosed design offers protection against dirt, leaves, ice and snow. Safety, function and freedom from maintenance with clear price advantages over conventional energy supply systems are the crucial criteria for selection.

## Advantages of lbt flizz®

- Guaranteed service life
- Cost-effective by comparison with conventional energy supply systems
- Protection of the cables against dirt, rain, sun, ice, snow and leaves
- Insensitive to wind movement
- Resistant to chemicals and solvents etc.
- Use of special cables possible, e.g. servo-drive cables, fiber-optic cables and bus systems etc.
- Virtually maintenance-free
- Easy and fast installation since it supplied as a made-to-spec system
- Easy integration in existing systems
- Cable length 50 % of travel

## Typical industries and applications

- Sludge scrapers
- Sand catchers
- Stormwater overflow tanks
- Electric plating plants
- Cranes
- Plant construction

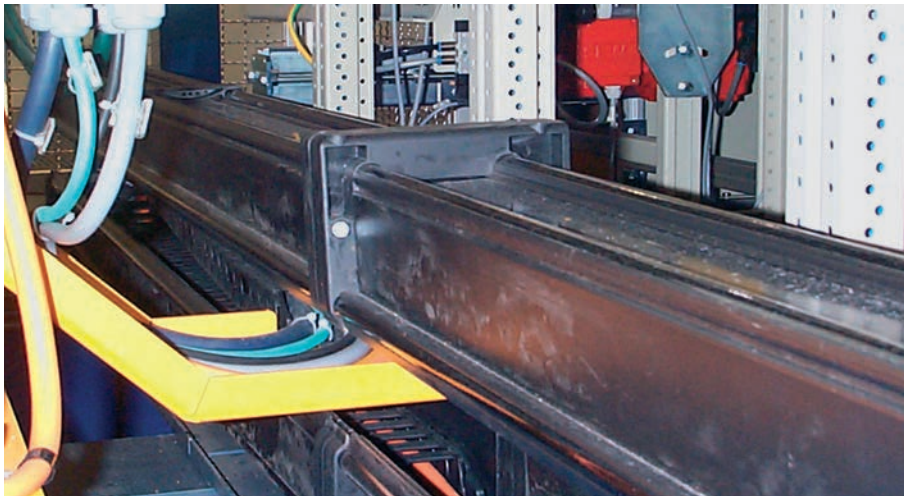



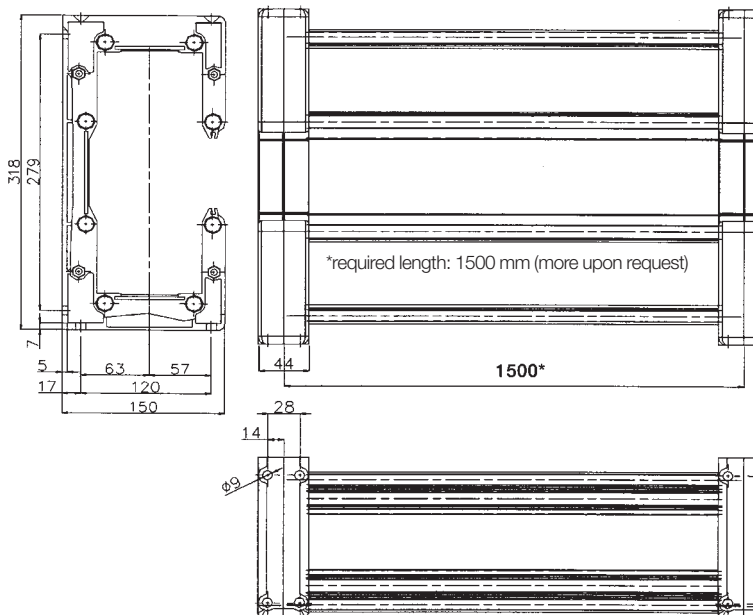

Installation variant for power infeed at fixed end



Example of mounting the console on jibs



## Design

- Solid plastic with powder-coated support tubes
- Modular design: the system can be closed with intermediate plates!
- Can be supplied preassembled
- Variable bays which are simply screwed together
- Glide bar integrated in profile

## Safe energy and data transfer

The igus® chainflex® range of cables offers a selection from over 1.030 different cables available from stock. This includes power, signal, data and bus systems including fibre optic cables. In addition, we can offer you all supply cables for your drive systems, such as motor, servo cables and encoder cables; all can be supplied made-to-spec with connectors.

## Cost-cutting installation

Thanks to the use of made-to-spec e-chainsystems®, you can greatly reduce expensive time incurred for installation and assembly at the installation site. Function-tested systems guarantee fast commissioning of the powered system sections.

## Installation service

We will be more than pleased to submit an offer to you for a full solution, including all installation services. This means that none of your own staff are tied up and, in future, you will have a trouble-free energy supply system at a fixed price.

## Outdoor use in sewage treatment plants

Because of the particular strain in sewage treatment plants, some with flooding, foam, etc., a safety margin for all load values of 50%, compared to applications in the inner/dry zone, should be made. A review of the application data by our project engineers is recommended.

The installation variant of a floating moving end for compensating for any lateral offset tolerances between scraper and e-chainsystem®



The scraper moves on the 38 m long final clarifier in round-the-clock operation. The energy supply is done via the lbt flizz® system



Space-saving and compact energy supply with lbt flizz® - Maintenance system, delivered pre-assembled with assembled igus® e-chain®



lbt flizz® in a longitudinal scraper travel (S) = 38 m  
 ● Speed (v) = 1.0 m/min. ● Acceleration (a) = 0.5 m/s<sup>2</sup>  
 ● Cycle time 1.5 x hour/ 24 h/365 days



Energy supply system protected from wind and weathering. The used materials are weather-resistant, as well as resistant against most chemicals, oils, fats, coolants and solvents



igus® lbt flizz® - Sewage works of the company Hydrobudowa S.A. in Poland. The power supply system of the scrapers in 8 clarifiers was equipped with igus® e-chain® and lbt flizz®. The complete system runs directly over the clarifier. Advantages:  
 ● Low-maintenance system ● Longer service life ● Enclosed trough, protection against snow and ice ● Space-saving compared to conventional system ● Compact and safe ● Travel (S) = 42 m ● Assembled with igus® chainflex® cables



**igus<sup>®</sup>**  
**micro flizz<sup>®</sup>**

small e-chains<sup>®</sup>  
in aluminum profile

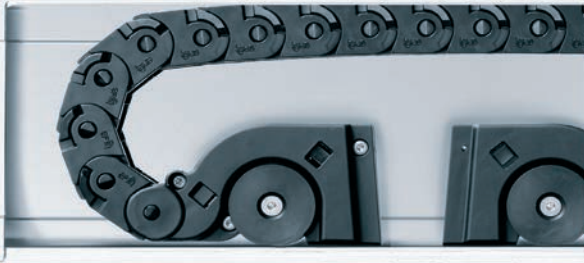
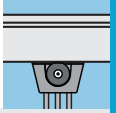

**Master long travels with the smallest e-chain® without failures**

- ONE compact system for a secure guidance of power, data and air
- Maintenance-free alternative for busbar
- e-chain® is guided in special slot, no sliding against each other
- Control via stationary switch cabinet possible
- Accelerations up to 50 m/s² and speeds up to 6 m/s
- Fast assembly due to pre-configured, modular system
- Less space required
- Available also as pre-assembled
- Smooth running due to ball bearings in the guide carriages
- Also with EX tested e-chain® available (on request)
- Rail material: anodized aluminum
- iF-Design Award

Cable diameter  
 MF06: max. Ø 8,0 mm  
 MF08: max. Ø 9,5 mm  
 MF10\*: max. Ø 16 mm  
 \*New in this catalog



**Typical industries and applications**

- Rack feeder ● Indoor cranes ● Industrial gates
- Working stations ● Sewage treatment plants ●
- Camera systems ● Sliding doors ● Operator panels
- Measure systems ● Studio equipment ●
- Conveyor technique

**Special feature: micro flizz® construction**

**Yesterday:** Moving lower run, sliding function. Long travels need stable e-chains®.

**Today: micro flizz®** - Small e-chains®, self-guiding in guiding channel - Friction is reduced by factor 3 over the conventional system.

# micro flizz® | Small e-chains® in aluminum profile

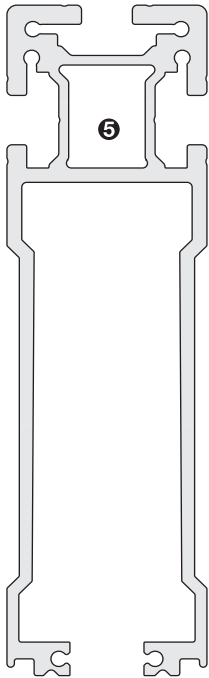

## Technical data micro flizz®

- ❶ Separated upper and lower run of the flizz® e-chain®, thus less friction and reduced push/pull forces
- ❷ Winglets hold the e-chain® secure in the guidance channel
- ❸ Polymer springs for a soft unrolling of the e-chain® in the flizz® channel effect a substantial noise reduction
- ❹ Integrated strain relief in the guide carriage for the safe fixing of cables
- ❺ Universal attachment options due to three T-grooves
- ❻ Attachment of the e-chain® by roller cart on the moving end, gliding or locking possible
- ❼ Opposed e-chains® can be used - a double filling or two independent travels are possible

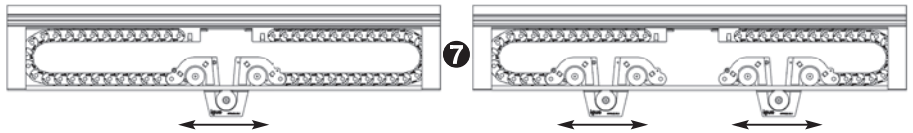
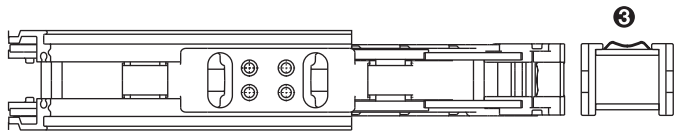
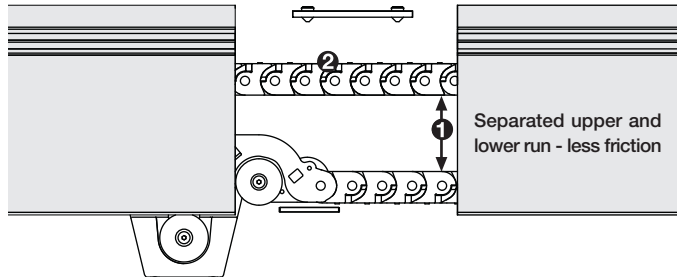

## Details micro flizz®



Separated upper and lower run:  
Running trough the radius,  
integrated winglets fold in

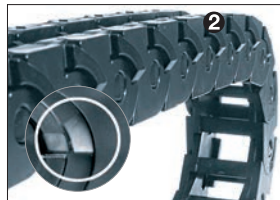

In the extended position, the  
winglets fold out and safely hold the  
upper run in the elevated position

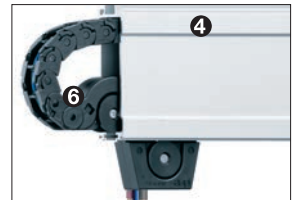

Power, data, pneumatics in confined  
areas. chainflex® cables are specifically  
designed for this challenge

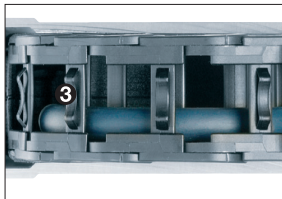

A polymer spring element  
cushions the motion inside the  
trough and lower noise



micro flizz® accessory:  
Connection for compressed  
air coupling



Potential application area of the micro  
flizz® - Storage and retrieval units for high-  
bay warehouses, indoor cranes, etc.

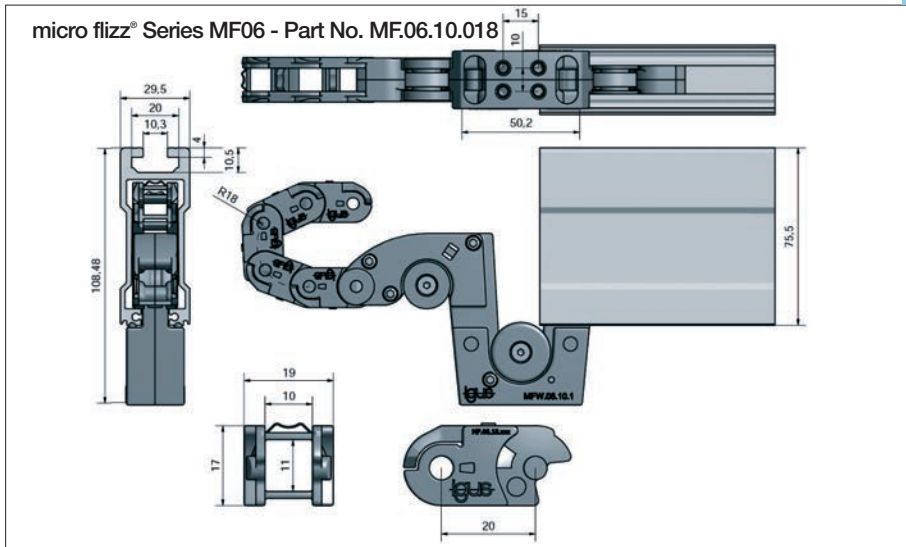
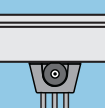

micro flizz® Series MF06 - Dimensions

Part No.	Bi	Ba	hi	ha	R Bending radius
MF.06.10.018	10	19	11	17	018

order example ► page 757

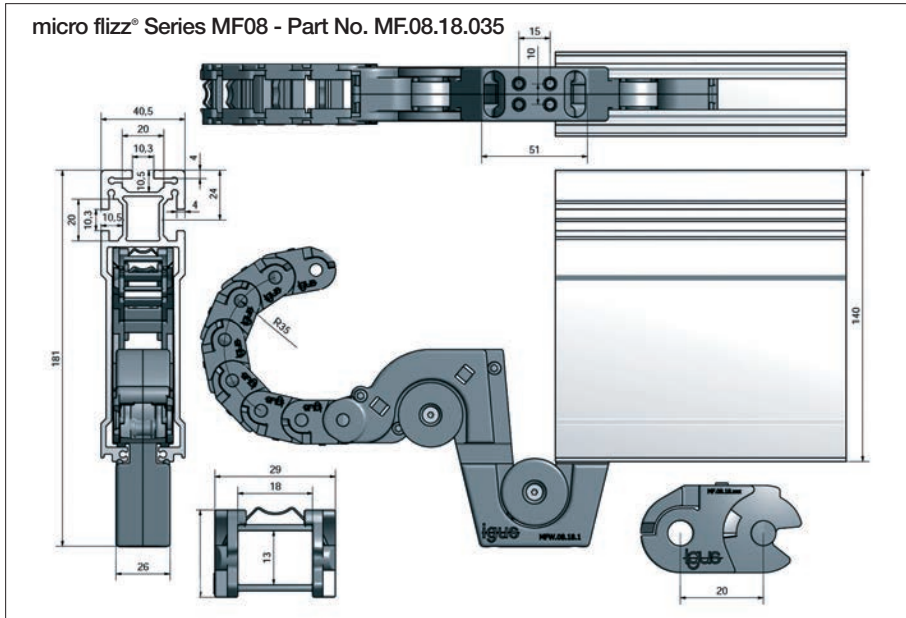

micro flizz® Series MF08 - Dimensions

Part No.	Bi	Ba	hi	ha	R Bending radius
MF.08.18.035	18	29	13	21	035

order example ► page 757

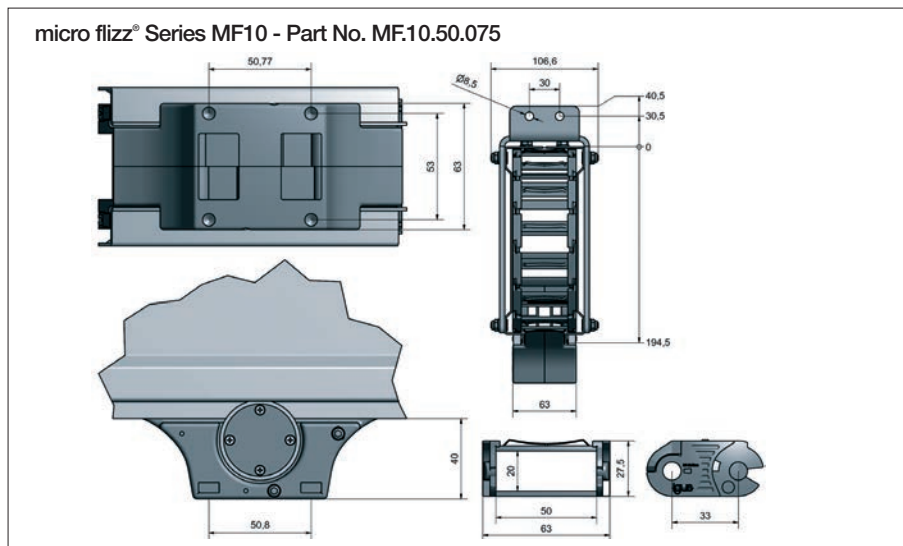

micro flizz® Series MF10 - Dimensions

Part No.	<i>Bi</i>	<i>Ba</i>	<i>hi</i>	<i>ha</i>	<i>R</i> Bending radius
MF.10.50.075	50	63	20	27,5	075

order example ► page 757

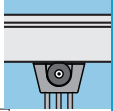

Order example - End feed

MF	XXX.	10.	R.	L / F
----	------	-----	----	-------

**MF.06.10.018.5000/2000** Series MF06  
**MF.08.18.035.5000/2000** Series MF08  
**MF.10.50.075.5000/2000** Series MF10



F = Field length [mm]  
 L = Total length [mm]  
 R = Bending radius [mm]  
 Bi = Inner e-chain® width [mm]  
 Type (Series)  
 micro flizz® end feed

Calculate the number of required channel pieces (n) thus:  

$$n = \frac{L}{F}$$
 Then round off the result.

micro flizz® as end feed option with a total length of 5000 mm, split into 2 channels each 2000 mm and 1 channel with a residual length of 1000 mm

- Bi = Inner e-chain® width [mm]
- R = Bending radius [mm]
- n = Number of channel pieces
- S = travel = L - 300 [mm]
- F = Field length [mm]
- L = Total length [mm]
- X = residual length [mm]

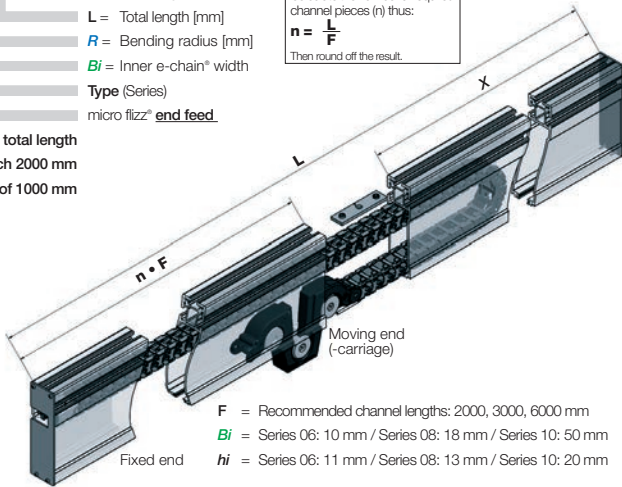

- F = Recommended channel lengths: 2000, 3000, 6000 mm
- Bi = Series 06: 10 mm / Series 08: 18 mm / Series 10: 50 mm
- hi = Series 06: 11 mm / Series 08: 13 mm / Series 10: 20 mm



Order example - 2 carriages in opposite directions

MFG2	XXX.	10.	R.	L / F
------	------	-----	----	-------

**MFG2.06.10.018.10000/3000** Series MF06  
**MFG2.08.18.035.10000/3000** Series MF08  
**MFG2.10.50.075.10000/3000** Series MF10



F = Field length [mm]  
 L = Total length [mm]  
 R = Bending radius [mm]  
 Bi = Inner e-chain® width [mm]  
 Type (Series)  
 micro flizz® 2 carriages

Calculate the number of required channel pieces (n) thus:  

$$n = 2 \cdot \frac{L - 200}{2 \cdot F}$$
 Then round off the result.

micro flizz® mounted with 2 carriages in opposite directions - Total length 10000 mm, split into 2 channels each 3000 mm, the feed module (200 mm) and 2 channels each 1900 mm residual length.

- Bi = Inner e-chain® width [mm]
- R = Bending radius [mm]
- n = Number of channel pieces
- S = travel = L - 300 [mm]
- F = Field length [mm]
- L = Total length [mm]
- X = residual length [mm]

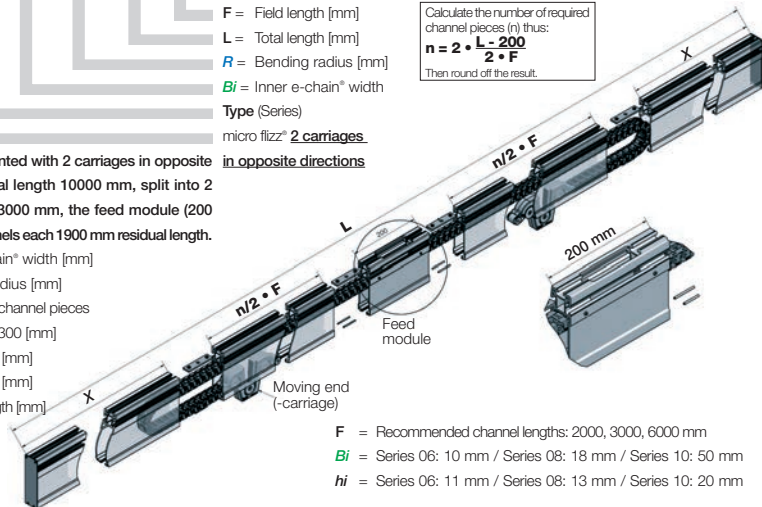

- F = Recommended channel lengths: 2000, 3000, 6000 mm
- Bi = Series 06: 10 mm / Series 08: 18 mm / Series 10: 50 mm
- hi = Series 06: 11 mm / Series 08: 13 mm / Series 10: 20 mm





micro flizz® in an outdoor application with 30 m travel



Energy supply to the strip at cold storage house doors, in operation for more than one year.



micro flizz® as energy supplying rail guide of a scale to weigh chemicals, etc.



Safe energy supply also under strong dust and dirt accumulation with igus® micro flizz®

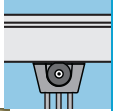

●  $s = 8,5 \text{ m}$  ●  $v = 4 \text{ m/s}$  ●  $a = 4 \text{ m/s}^2$  ● Filling: 1x CF9.15.04  
● Running performance ca. 15.000 km without failure (issue 06.2006)



●  $s = 40 \text{ m}$  ●  $v = 4 \text{ m/s}$  ●  $a = 1 \text{ m/s}^2$  ●  $m_{\text{Chain}} = 0,21 \text{ kg/m}$   
●  $m_{\text{Cable}} = 0,09 \text{ kg/m}$  ● Filling: 1 x CF98.05.04

# igus<sup>®</sup> modular system for projects



# Modular system for projects | Fast, all ex-stock

## The igus® modular system for projects

Special components, tested and time-proven in numerous projects, have now become available as a modular standard system.

- Faster quotations
- Faster project planning
- Detailed service manuals and documentation
- Time and cost savings
- Safe function
- System warranty available upon request, for individual applications

### Available modules of such a modular system for projects entail, for example:

- PPDS tow arm with electronic push/pull force monitoring
- Fixation point modules for easy attachment of the e-chain® inside the guide trough, with no drilling required
- Extreme gliders gliding elements for even longer cycle life of e-chains® on long travels
- HD Heavy-Duty trough systems from various materials and with different assembly kit designs, matching the respective application and stress levels

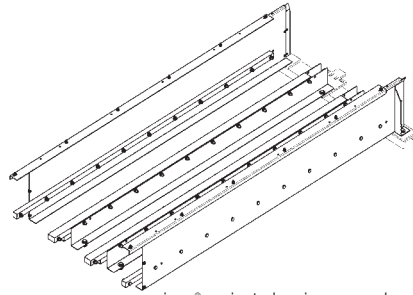

igus® project planning example, here: guide trough modules

### Typical industries and applications

Cranes, offshore and many more

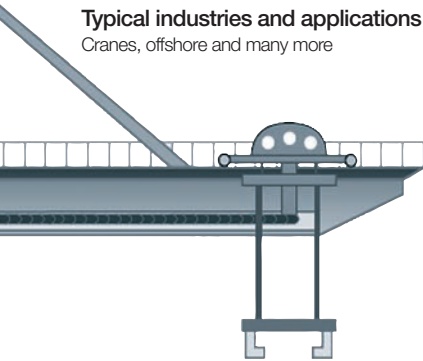

Long travels with electronics Push/Pull-force monitoring with the igus® PPDS System



igus® supervisors plan projects worldwide



Crane system designed by igus®



# igus<sup>®</sup> fax-forms & addresses



<b>Date:</b> _____	<b>Phone:</b> +49- (0) 22 03 96 49 - 800 <b>Fax:</b> +49- (0) 22 03 96 49 - 222
<b>From:</b> _____  <b>Phone:</b> _____ <b>Fax:</b> _____	<b>To:</b> <b>igus® GmbH</b> <b>Technical Sales</b> <b>e-chainsystems®</b> <b>Spicher Str. 1a</b> <b>51147 Cologne</b>

 (Type of Application - please mark with a cross) **Installation Space**

 Unsupported application <input type="checkbox"/>	 Gliding application <input type="checkbox"/>	 Hanging application <input type="checkbox"/>	 Standing application <input type="checkbox"/>	 Side-mounted application <input type="checkbox"/>	 Rotary motion application <input type="checkbox"/>	 Horizontal + vertical <input type="checkbox"/>	 Nested application <input type="checkbox"/>	 Side by side application <input type="checkbox"/>	 Zig-Zag application <input type="checkbox"/>	 Combined motions <input type="checkbox"/>
<b>Travel S</b> _____ [mm]		<b>Fixed end</b> center of travel <input type="checkbox"/> yes or _____ [mm] from the center				<b>Construction width</b> Max. width permitted? _____ [mm]				
		<b>R desired</b> _____ [mm]		<b>Max installation height</b> $H_F$ _____ [mm]		<b>Guide trough?</b> <input type="checkbox"/> yes, if yes which: Dim.: $B_{Ri}$ _____ [mm] Dim.: $H_{Ri}$ _____ [mm]				
<b>Assembly point (floor, wall, console, etc.)</b> _____ [mm]				<b>Span (standard = 2 m)</b> _____ [mm]						

**Dynamics**

<b>Speed</b> _____ [m/s]	<b>Acceleration</b> _____ [m/s <sup>2</sup> ]	<b>Ø Outer diameter</b> _____ [mm]
<b>Cycles/Day</b> _____	<b>Days/Year</b> _____	

**Environment**

<b>Temperature</b> _____ [°C]	<b>Humidity</b> _____ [%]	<b>Dust, dirt, chips</b> _____
<b>Special parameters</b> _____		

Number	Manufacturer/Type, No.	Conductor/AWG	Ø [mm]	Weight [kg/m]	Bending Radius
--------	------------------------	---------------	--------	---------------	----------------

**Cables/Hoses**

<b>Further individual components desired:</b>	
e-chains® / e-tubes <input type="checkbox"/>	e-chain® <input type="checkbox"/>
chainflex® cables/special conduits <input type="checkbox"/>	e-tube <input type="checkbox"/>
Guide troughs <input type="checkbox"/>	To be opened on both sides <input type="checkbox"/>
Strain relief <input type="checkbox"/>	Along the outer radius <input type="checkbox"/>
Harnessing <input type="checkbox"/>	Along the inner radius <input type="checkbox"/>
On-site assembly <input type="checkbox"/>	Special requests _____ <input type="checkbox"/>
Others _____ <input type="checkbox"/>	

# Fax | e-chainsystems® | Harnessing application

<b>Date:</b>	<b>Phone:</b> +49- (0) 22 03 96 49 - 800 <b>Fax:</b> +49- (0) 22 03 96 49 - 222
<b>From:</b>  <b>Phone:</b> <b>Fax:</b>	<b>To:</b> <b>igus® GmbH</b> Technical Sales e-chainsystems® Spicher Str. 1a 51147 Cologne

e-chain® type

Length

**Cable/hose requirements:**

---



---



---



---



---



---

**Interior separation / Vertical separators**  
Cable/hose layout within carrier

Cable/Hose End 1	Connector End 1	Union 1	Cable/Hose End 2	Union 2	Connector End 2



# Fax | Project analysis | Zig-Zag application

Date:	Phone: +49- (0) 22 03 96 49 - 800 Fax: +49- (0) 22 03 96 49 - 222
From:	To: <b>igus® GmbH</b> Technical Sales e-chainsystems® Spicher Str. 1a 51147 Cologne
Phone:	
Fax:	

Zig-Zag application - Installation space

**Zig-Zag travel:**

Strokes (x4) \_\_\_\_\_ [mm]

Connection height (x5) \_\_\_\_\_ [mm]

e-chain® Series \_\_\_\_\_ Min. permitted radius \_\_\_\_\_ [mm] Max. additional load \_\_\_\_\_ [kg/m]

**Zig-Zag box:**

Max. height (x1) \_\_\_\_\_ [mm]

Max. length (x3) \_\_\_\_\_ [mm]

Dynamics

Speed \_\_\_\_\_ [m/s]    Acceleration \_\_\_\_\_ [m/s²]    Ø Outer diameter \_\_\_\_\_ [mm]

Cycles/Day \_\_\_\_\_    Days/Year \_\_\_\_\_

Environment  
Cables/Hoses

Temperature \_\_\_\_\_ [°C]    Humidity \_\_\_\_\_ [%]    Special parameters \_\_\_\_\_

Number	Manufacturer/Type, No.	Conductor/AWG	Ø [mm]	Weight [kg/m]	Bending Radius

**Further individual components desired:**

<input type="checkbox"/> e-chains® / e-tubes	<input type="checkbox"/>	<input type="checkbox"/> e-chain®	<input type="checkbox"/>
<input type="checkbox"/> chainflex® cables/special conduits	<input type="checkbox"/>	<input type="checkbox"/> e-tube	<input type="checkbox"/>
<input type="checkbox"/> Guide troughs	<input type="checkbox"/>	<input type="checkbox"/> To be opened on both sides	<input type="checkbox"/>
<input type="checkbox"/> Strain relief	<input type="checkbox"/>	<input type="checkbox"/> Along the outer radius	<input type="checkbox"/>
<input type="checkbox"/> Harnessing	<input type="checkbox"/>	<input type="checkbox"/> Along the inner radius	<input type="checkbox"/>
<input type="checkbox"/> On-site assembly	<input type="checkbox"/>	<input type="checkbox"/> Special requests _____	<input type="checkbox"/>
<input type="checkbox"/> Others _____	<input type="checkbox"/>		

Date:	Phone: +49- (0) 22 03 96 49 - 800 Fax: +49- (0) 22 03 96 49 - 222
From:	To: <b>igus® GmbH</b> Technical Sales e-chainsystems® Spicher Str. 1a 51147 Cologne
Phone:	
Fax:	

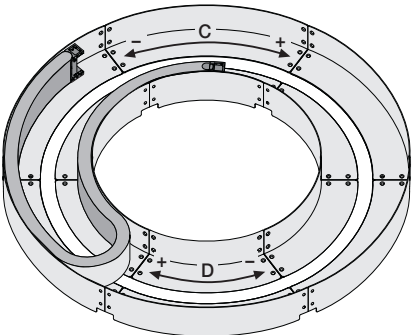
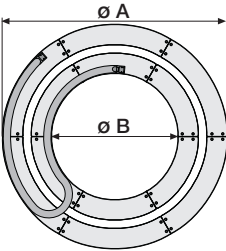
<p>Side View</p> <p>h _____ [mm]</p> 	<p>3D View</p> <p>C Outer rotating <input type="checkbox"/></p> <p>D Inner rotating <input type="checkbox"/></p> <p>Rotation angle: ± _____ [°/mm]</p> 
<p>Top View</p> <p>Ø A _____ [mm]</p> <p>Ø B _____ [mm]</p> 	

RBR application - Installation space

Speed \_\_\_\_\_ [m/s]    Acceleration \_\_\_\_\_ [m/s²]    Ø Outer diameter \_\_\_\_\_ [mm]

Cycles/Day \_\_\_\_\_    Days/Year \_\_\_\_\_

Dynamics

Temperature \_\_\_\_\_ [°C]    Kind of \_\_\_\_\_ (e.g. chips) \_\_\_\_\_

Humidity \_\_\_\_\_ [%]    ESD \_\_\_\_\_

Dirt/Dust \_\_\_\_\_    Special parameters \_\_\_\_\_

Environment

Number	Manufacturer/Type, No.	Conductor/AWG	Ø [mm]	Weight [kg/m]	Bending Radius

Cables/Hoses

<p><b>Additional</b></p> <p><b>Guide Trough RBR</b></p> <p>Material <input type="checkbox"/> galvanized    <input type="checkbox"/> 1.4301 (304) <input type="checkbox"/> 1.4404 (316L)    <input type="checkbox"/> 1.4571 (316Ti)</p> <p>Supports/Brackets <input type="checkbox"/> by igus®    <input type="checkbox"/> by customer</p> <p>Cover needed? <input type="checkbox"/> yes    <input type="checkbox"/> no</p>	<p>Drawing/sketch from customer available? <input type="checkbox"/></p> <p>Drawing/sketch desired by igus*? <input type="checkbox"/></p> <p>Special requests/notes _____</p> <p>_____</p>
--	---

<b>igus® offices</b>	<b>11 China</b>	<b>19 Finland</b>	<b>27 Israel</b>	<b>38 Netherlands</b>
<b>igus® distributors</b>	<p><b>igus® Shanghai Co., Ltd.</b> No.46 Warehouse, 11 Dabao Road, WGGQ FTZ, Shanghai 200131, P.R.China Shanghai 200131, P.R.C. Phone +86 21 51303100 Fax +86 21 51303200 master@igus.com.cn</p>	<p><b>SKS Mekaniikka Oy</b> Marinkyläntie 50 01720 Vantaa Phone +358 20 7646522 Fax +358 20 7646824 mekaniikka@sk.fi</p>	<p><b>Conlog LTD</b> P.O. Box 3265 17 Hamfalassim Str. Industrial Zone Kiryat Arie Petach-Tikva 49130 Phone +972 3 9269595 Fax +972 3 9233367 conlog@conlog.co.il</p>	<p><b>igus® B.V.</b> Sterrenbergweg 9 3769 BS Soesterberg Phone +31 346 353932 Fax +31 346 353849 igus.nl@igus.de</p>
<b>1 Germany</b>	<p><b>12 Colombia</b></p> <p><b>Colsein Ltd</b> Calle 82 # 5-48 Bogota Phone +57 6108448-121 mercadeo@colsein.com.co</p>	<b>19 Finland – chainflex®</b>	<b>28 Italia</b>	<b>38 Netherlands – Bearings</b>
<p><b>igus® GmbH</b> Spicher Str. 1a 51147 Köln P.O.Box 90 61 23 51127 Köln Phone +49 2203 9649-0 Fax +49 2203 9649-222 info@igus.de, www.igus.de</p>	<p><b>13 Costa Rica</b></p> <p><b>Enesa Equipos Neumaticos S.A.</b> Del Colegio Marista 100 este, 200 sur, 25 este Urbanizacion Ciruelas Alajuela, Costa Rica Phone +506 2440-2393 Fax +506 2440-2393 equiposneumaticos@enesa.net</p>	<p><b>SKS Autoomaatio Oy</b> Marinkyläntie 50 01720 Vantaa Phone +358 20 7646748 Fax +358 20 7646820 autoomaatio@sk.fi</p>	<p><b>igus® S.r.l.</b> Via delle Rovedine, 4 23899 Robbiate (LC) Phone +39 039 5906.1 Fax +39 039 5906.222 igusitalia@igus.it</p>	<p><b>Elcee Holland BV</b> Kamerlingh Onnesweg 28 NL-3316 GL Dordrecht Phone +31 78 6544777 Fax +31 78 6544733 info@elcee.nl</p>
<b>2 Australia</b>	<p><b>23 Costa Rica</b></p> <p><b>Enesa Equipos Neumaticos S.A.</b> Del Colegio Marista 100 este, 200 sur, 25 este Urbanizacion Ciruelas Alajuela, Costa Rica Phone +506 2440-2393 Fax +506 2440-2393 equiposneumaticos@enesa.net</p>	<b>20 France</b>	<b>29 Italia</b>	<b>39 New Zealand</b>
<p><b>Treotham Automation Pty. Ltd.</b> 14 Sydenham Road Brookvale NSW 2100 Phone +61 2 9907-17 88 Fax +61 2 9907-1778 info@treotham.com.au</p>	<p><b>24 Croatia</b></p> <p><b>Hennlich, Industrijska d. o. o.</b> Stupni koobreška 17 Stupni ki Obraz 10295 Goml Stupnik Phone +385 1 3874334 Fax +385 1 3874336 hennlich@hennlich.hr</p>	<p><b>igus® SARL</b> 49, avenue des Pépinières Parc Médicus 94260 Fresnes Phone +33 1 49840404 Fax +33 1 49840394 info@igus.fr</p>	<p><b>igus® k.k.</b> Arcacental 15F, 1-2-1 Kinshi, Sumida-ku Tokyo JAPAN Zip 130-0013 Phone +81 358 192030 Fax +81 358 192055 info@igus.co.jp</p>	<p><b>Automation Equipment Ltd.</b> 26 Tawn Place PO Box 5656 Hamilton Phone +64 7 8490281 Fax +64 7 8492422 sales@autoequip.co.nz</p>
<b>3 Austria</b>	<p><b>14 Croatia</b></p> <p><b>Hennlich, Industrijska d. o. o.</b> Stupni koobreška 17 Stupni ki Obraz 10295 Goml Stupnik Phone +385 1 3874334 Fax +385 1 3874336 hennlich@hennlich.hr</p>	<p><b>21 Greece – e-chains®</b></p> <p><b>Chrismotor s.a.</b> 71, Sp. Patsi str. 118 55 Athens Phone +30 210 34 25574 Fax +30 210 3425595 info@chrismotor.gr</p>	<p><b>29 Japan</b></p> <p><b>igus® k.k.</b> Arcacental 15F, 1-2-1 Kinshi, Sumida-ku Tokyo JAPAN Zip 130-0013 Phone +81 358 192030 Fax +81 358 192055 info@igus.co.jp</p>	<p><b>40 Norway/Iceland</b></p> <p><b>ASI Automatik AS</b> Ingv. Ludvigssensgate 23 3007 Drammen Phone +47 9006 1100 info@asiflex.no</p>
<b>4 Argentina</b>	<p><b>15 Czech Republic</b></p> <p><b>Hennlich s.r.o.</b> Českálipská 9 412 01 Litoměřice Phone e-chains® +420 416 711332 Phone bearings +420 416 711339 Fax +420 416 711999 lin-tech@hennlich.cz</p>	<p><b>21 Greece – Bearings</b></p> <p><b>J. &amp; E. Papadopoulos S.A.</b> 12, Polidefous str Piraeus, 185 40 Phone +30 210 4113133 Fax +30 210 4116781 sales@papadopoulos-sa.com</p>	<p><b>30 Jordan</b></p> <p><b>Al Hezam Adtech</b> Abu Alanda Street ,Building No. 1 Amman Phone +962 64 170100 Fax: +962 64 169993 info.jod@adtech-trading.com</p>	<p><b>41 Peru</b></p> <p><b>Profaco S.A.C.</b> Calle Bolívar 388/of. 203 Miraflores Lima 18 – Perú Phone +51 1 2414370 Fax +51 1 2428608 ventas@profaco.com</p>
<b>5 Belarus</b>	<p><b>16 Denmark</b></p> <p><b>igus® ApS</b> Postboks 243 8800 Viborg Phone +45 86 603373 Fax +45 86 603273 info@igus.dk</p>	<p><b>22 Hong Kong</b></p> <p><b>Sky Top Enterprises Ltd.</b> Room 1707, Block C, Wah Tat Ind Centre; Wah Sing Street; Kwai Chung; Hong Kong Phone +852 22434278 Fax +852 22434279 skytopy@ctmail.com</p>	<p><b>31 Latvia</b></p> <p><b>INPAP</b> Katrinas Str. 16 Phone +371 7509404 Fax +371 7509403 office@inpap.lv</p>	<p><b>42 Philippines</b></p> <p><b>Silicon Exponents Corp.</b> Suite 6A, 8414 Dr. A. Santos Ave., Sucat, 1700 Paranaque City, Metro Manila Phone +63 2 8250126 Fax +63 2 8250141 sales_philippines@igus.com.sg</p>
<b>6 Belgium/Luxembourg</b>	<p><b>16 Denmark – e-chains®</b></p> <p><b>Solar A/S</b> Industrivej Vest 43 6600 Vejen Phone +45 75 961200 Fax +45 75 3647 59 solar@solar.dk</p>	<p><b>23 Hungary</b></p> <p><b>igus® Hungária Kft.</b> Mogyoródi u.32. 1149 Budapest Phone +36 1 3066486 Fax +36 1 4310374 info@igus.hu</p>	<p><b>32 Lebanon</b></p> <p><b>Mecanix Shops</b> Gebrhas Safi Charles Helou Avenue Beirut Phone +961 1 486701 Fax +961 1 490929 mecanix@dm.net.lb</p>	<p><b>43 Poland</b></p> <p><b>igus® Sp. z o.o.</b> ul. Nakielska 3 01-106 Warszawa Phone +48 22 8635770 Fax +48 22 8636169 info@igus.pl</p>
<b>7 Brazil</b>	<p><b>17 Ecuador</b></p> <p><b>Ecuaínsetec</b> El Zurmigo E9-32 y el Vengador Quito Phone +593 2 2253757 Fax +593 2 2461833 info@ecuaínsetec.com.ec</p>	<p><b>23 Hungary</b></p> <p><b>Tech-Con Kft.</b> Vésó utca 9-11 1133 Budapest Phone +36 1 4124161 Fax +36 1 4124171 tech-con@tech-con.hu</p>	<p><b>33 Lithuania</b></p> <p><b>Hitech UAB</b> Terminalo g. 3 54469 Biruliškiu k. Kauno raj. Phone +371 67509404 Fax +371 67509403 info@hitech.lt</p>	<p><b>44 Portugal</b></p> <p><b>igus® Lda.</b> R. Eng. Ezequiel Campos, 239 4100-231 Porto Phone +351 22 6109000 Fax +351 22 8328321 info@igus.pt</p>
<b>8 Bulgaria</b>	<p><b>18 Egypt</b></p> <p><b>Fedicom Trading</b> <b>Mohamed Fayed Sami &amp; Co.</b> 12, El Mahaad El Swissri St., Fiat 10 – 2nd Floor-Zamalek Cairo – A.R of Egypt Phone +202 27362537 Fax +202 27363196 mohamed.fayed@fedicom.com</p>	<p><b>24 India</b></p> <p><b>igus® (India) Pvt. Ltd.</b> 36/1, Sy No. 17/3 Euro School Road, Dodda Nekundi Industrial Area - 2nd Stage Mahadevapura Post Bangalore 560048 Phone +91 80 39127800 Fax +91 80 39127802 info@igus.in</p>	<p><b>35 Malaysia</b></p> <p><b>igus® Malaysia Sdn Bhd</b> No. 19-1, Jalan PUJ 1/3F Sunway Mas Commercial Centre 47301 Petaling Jaya Selangor D.E. Phone +603 78805475 Fax +603 78805479 sales_malaysia@igus.de</p>	<p><b>45 Romania</b></p> <p><b>Tech-Con Industry SRL</b> Calea Crangasi nr. 60 060346 Bucuresti Phone +40 21 2219-640 Fax +40 21 2219-766 automatizari@meteor.ro</p>
<b>9 Canada</b>	<p><b>18 Egypt</b></p> <p><b>Fedicom Trading</b> <b>Mohamed Fayed Sami &amp; Co.</b> 12, El Mahaad El Swissri St., Fiat 10 – 2nd Floor-Zamalek Cairo – A.R of Egypt Phone +202 27362537 Fax +202 27363196 mohamed.fayed@fedicom.com</p>	<p><b>25 Indonesia</b></p> <p><b>igus® Singapore Pte Ltd.</b> 15 Shaw Road, #03-02 Singapore 367953 Phone +62 812 986 11002 Fax: +65 6487 1511 sales_indonesia@igus.com.sg</p>	<p><b>36 Morocco</b></p> <p><b>AFIT</b> 5, Rue Amir Abdelkader 20300 Casablanca Phone +212 522 633769 Fax +212 522 618351 souria.vu@premium.net.ma</p>	<p><b>45 Romania</b></p> <p><b>Hennlich SRL</b> Str. Patria, Nr17 310106 Arad Phone +40 257 211119 Fax +40 257 212101 igus@hennlich.ro</p>
<b>10 Chile</b>	<p><b>18 Egypt</b></p> <p><b>IEE International Company for Electrical Engineering</b> 2nd floor, 25 Orabi St Down Town, Cairo Phone +202 25767370 Fax +202 25767375 kamel@iee-egypt.com</p>	<p><b>26 Ireland</b></p> <p><b>igus® Ireland</b> 51A Caswell Road Brackmills Northampton NN4 7PW Phone +44-1604 677240 Fax +44-1604 677242 sales@igus.ie</p>	<p><b>37 Mexico</b></p> <p><b>igus® México S. de RL de CV.</b> Boulevard Aeropuerto Miguel Aleján 160 Int. 135 Col. Corredor Industrial Toluca Lerma Lerma, Estado de Mexico C.P. 52004 Phone +52 728284 3185 Fax +52 728284 3187 fmartinez@igus.com</p>	<p><b>46 Russia</b></p> <p><b>OOO Hennlich</b> Ozernaja 16 building 1, office 4 170008 Tver Phone +7 4822630-180 Fax +7 4822630-180 hennlich@hennlich.ru</p>

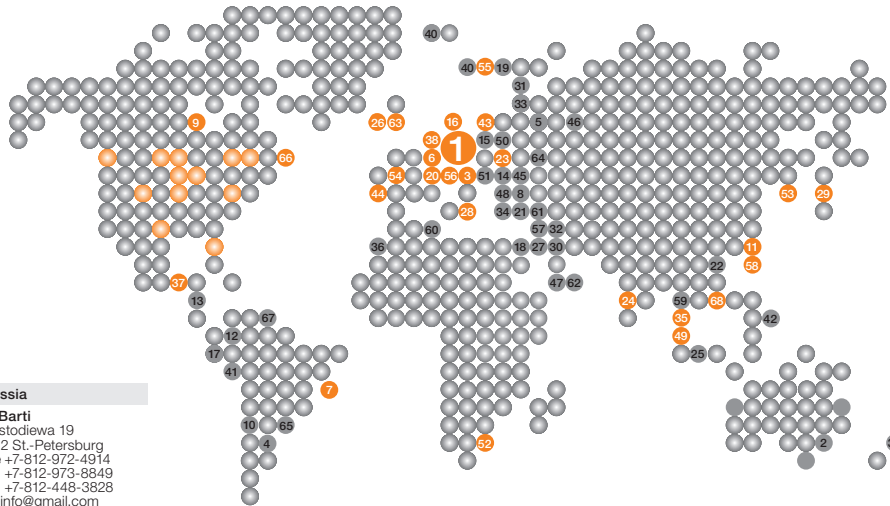

#### 46 Russia

**OOO Barti**  
Ul. Kustodievla 19  
194352 St. Petersburg  
Phone +7-812-972-4914  
+7-812-973-8849  
Fax +7-812-448-3828  
bartix.info@gmail.com

#### 46 Russia

**OOO Eka-Service Kompani**  
1-aja Dubrowskaja, 2A, k. 35  
109044 Moskva  
Phone +7 495 6326623  
Fax +7 495 6771778  
zakaz@ekaservice.ru

#### 47 Saudi Arabia

**AFI**  
Khalaf Bin Hesham Street  
Box 9998  
31423 Dammam  
Phone +966 38740033  
Fax +966 38470077  
marketing@afi.com.sa

#### 48 Serbia + Montenegro

**Hennlich doo Beograd**  
Ul. S. Markovica 3/4  
11400 Mladenovac  
Mob.: +381 65 58 81 550  
Office: +381 64 18 81 549  
info@hennlich.rs

#### 49 Singapore - HQ ASEAN

**igus® Singapore Pte Ltd.**  
15 Shaw Road, #03-02  
Singapore 367953  
Phone +65 6487-1411  
Fax +65-6487-1511  
Hotlines #:  
Malaysia +603 7880 5475  
Thailand +668 1902 1113  
Vietnam +84 90 929 4487  
Indonesia +62 812 986 11002  
asia-sales@igus.de

#### 50 Slovakia

**Hennlich Industrietechnik s.r.o.**  
Miletičova 16  
SK-821 08 Bratislava  
Phone +421 2 50202504  
Fax +421 2 50202520  
technik@hennlich.sk

#### 51 Slovenia

**Hennlich, d. o. o.**  
Industrijska tehnika  
Podnart 33  
SI-4244 Podnart  
Phone +386 4 53206-10  
Fax +386 4 53206-20  
info@hennlich.si

#### 52 South Africa

**igus® Pty. Ltd.**  
Unit 29  
Midline Business Park  
Cnr Le Roux & Richards Drive  
Midrand 1682  
Phone +27 11312-1848  
Fax +27 11312-1594  
sales.sa@igus.de

#### 53 South Korea

**igus® Korea Co. Ltd.**  
613-14 Namchondong,  
Namdonggu  
Incheon City, 405-300  
Phone +82 32 82129-11  
Fax +82 32 82129-13  
info@igus.kr

#### 54 Spain

**igus® S.L.**  
C/ Llobatona, 6  
Polígono Noi del Sucre  
08840 Viladecans - BCN  
Phone +34 936 473950  
Fax +34 936 473951  
igus.es@igus.es

#### 55 Sweden

**igus® ab**  
Knut Påls väg 8  
256 69 Helsingborg  
Phone +46 42 329270  
Fax +46 42 211585  
info@igusab.se

#### 55 Sweden - e-chains®

**OEM Automatic AB**  
Box 1011 Dalagatan 4  
573 28 Tranås  
Phone +46 75 2424100  
Fax +46 75 2424159  
info@aut.oem.se

#### 55 Sweden - Bearings

**Colly Components AB**  
P.O. Box 76  
164 94 Kista  
Phone +46 8 7030100  
Fax +46 8 7039841  
info@me.colly.se

#### 56 Switzerland

**igus® Schweiz GmbH**  
Winkelstr. 5  
4622 Egerkingen  
Phone +41 62 3889797  
Fax +41 62 3889799  
info@igus.ch

#### 57 Syria

**ETTA Systems**  
Al-Hamma St. Shalan Building  
12850 Damascus  
Phone +96 311 332 5519  
Fax: +96 311 334 2639  
info@ettasystems.com

#### 58 Taiwan

**igus® Taiwan Company Ltd.**  
5F, No. 35, 24th Road  
Taichung Industrial Park  
Taichung 40850  
Phone +886 4 2358-1000  
Fax +886 4 2358-1100  
info@igus.com.tw

#### 59 Thailand

**Autoflexible Advanced Engineering Co., Ltd.**  
111 Soi, Sukhumvit,  
62/1 Sukhumvit Rd,  
Bangkok, Phakanong,  
Bangkok 10260  
Phone +66 2 3112111  
Fax +66 2 3327900  
sales\_thailand@igus.com.sg

#### 60 Tunisia

**BOUDRANT**  
53, Avenue de Carthage  
1000 Tunis - Tunisia  
Phone +216 71340244  
Fax +216 71348910  
info@boudrant.com.tn

#### 61 Turkey

**HIDREL Hidrolik Elemanlar**  
Sanayi ve Ticaret A.S.  
Perçemli Sk. No. 7  
Tünel Mevki  
34420 Karaköy / Istanbul  
Phone +90 212 2494881  
Fax +90 212 2920850  
info@hidrel.com.tr

#### 62 United Arab Emirates

**Unigroup (FZE)**  
1st floor Rasana  
Building M602  
P.O. Box 120300  
Sharjah - UAE  
Phone +971 6 5578386  
Fax +971 6 5578387  
automation@unigroup.ae

#### 62 United Arab Emirates

**Power & Technology Trading Co. L.L.C**  
P.O. Box 33372 SHJ  
Sharjah - UAE  
Phone +971 6 5421300  
Fax +971 6 5423700  
sales@powertech.ae

#### 63 United Kingdom

**igus® UK Ltd.**  
51A Caswell Road  
Brackmills  
Northampton NN4 7PW  
Phone +44 1604 677240  
Fax e-chain®  
+44 1604 677242  
Fax Bearing  
+44 1604 677245  
sales@igus.co.uk

#### 64 Ukraine

**Cominpro Ltd.**  
Romena Rollana 12,  
Office 220  
61058 Kharkov  
Phone +38 0577174914  
Fax +38 0577174914  
cominpro@gmail.com

#### 64 Ukraine

**Hennlich Ukraine LLC (HO)**  
Galicja Street 15  
84100 Sloviansk City,  
Donetsky Region  
Phone +38 06262 33540  
hennlich@hennlich.com.ua

#### 65 Uruguay

**Larrique Rulemanes SA**  
Galicja 1204  
Montevideo-Uruguay  
Phone +598 29021773  
Fax +598-29084824  
larrique@larrique.com.uy

#### 66 USA

**igus® inc.**  
50 N. Broadway  
P.O. Box 14349  
East Providence, RI 02914  
Phone +1 401 4382200  
Fax +1 401 4387270  
webmaster@igus.com

#### 67 Venezuela

**Neumatica Rotonda C.A.**  
Prolong Av. Michelena  
C.C. Atlas Locales B-10 y  
B-11  
Valencia, Edo. Carabobo  
Phone +58 241 832.64.64  
+58 241 832.32.50  
+58 241 838.88.19  
Fax +58 241 832.62.83  
ventas@neumaticar.com

# 8.00am-8.00pm

Ordering and deliveries weekdays from 8.00 am - 8.00 pm,  
Saturday from 8.00 am - 12.00 pm. No minimum order quantities,  
no surcharges. Prompt delivery.

[www.igus.eu](http://www.igus.eu) Phone +49-2203-9649-800 Fax -222

# igus<sup>®</sup>.eu/24

Online shopping - 24h! [www.igus.eu/24](http://www.igus.eu/24)

# /9001:2008

igus<sup>®</sup> is certified in accordance with DIN EN ISO 9001:2008  
and ISO/TS 16949:2009 in the field of energy chains<sup>®</sup> with  
cables and harnessing, as well as plastic plain bearings.

# /readychain<sup>®</sup>

Ask for fully harnessed and preassembled  
readychains<sup>®</sup> - increase your cash-flow  
and profit immediately. [www.readychain.eu](http://www.readychain.eu)

# igus<sup>®</sup>.eu/...

igus<sup>®</sup> GmbH Spicher Str. 1a 51147 Cologne  
Phone. +49-2203-9649-0 Fax +49-2203-9649-222  
[info@igus.de](mailto:info@igus.de) [www.igus.eu](http://www.igus.eu)

© igus<sup>®</sup> GmbH - 05/2013 - Subject to technical alterations!  
MAT0072320.20, Issue 06/2013

# plastic